

**DESIGN AND IMPLEMENTATION OF QUADRILATERAL RELAY  
USING MICROCONTROLLER ATmega328 FOR THE PROTECTION  
OF TRANSMISSION LINE EQUIVALENT MODEL**

*A Dissertation submitted in partial fulfillment of the requirements for the award of degree*

*Of*

**MASTER OF ENGINEERING**

*In*

**Power Systems**

*Submitted by*

**Rayees Ahmad**

**(Regn. No 801341020)**

*Under the guidance of*

**Dr. Amrita Sinha**

**Assistant Professor, EIED**



**JULY 2015**

**Electrical and Instrumentation Engineering Department**

**Thapar University, Patiala**

*(Declared as Deemed-to-be-University u/s 3 of the UGC Act., 1956)*

**Post Bag No. 32, Patiala – 147004**

**Punjab (India)**

# DECLARATION

I hereby certify that the work which is presented in dissertation entitled, "Design and Implementation of Quadrilateral relay using microcontroller ATmega328 for the protection of Transmission Line equivalent model," in partial fulfillment of the requirements for the award of the degree of Master of Engineering in Power Systems and Electric Drives, submitted to Electrical & Instrumentation Engineering Department of Thapar University, Patiala is as authentic record of my own work carried under the supervision of Dr. Amrita Sinha. It refers others researcher's work which are duly listed in the reference section. The matter contained in this dissertation has not been submitted, neither in part, nor in full to any other degree to any other university or institute except as reported in text and references.

Place: Patiala

Date: 17-07-15

  
(Rayees Ahmad)  
Roll No.: 801341020

It is certified that the above statement made by the student is correct to the best of my knowledge and belief.

Date: 15/07/15

  
(Dr. Amrita Sinha)  
Assistant Professor  
Electrical & Instrumentation Engineering Department  
Thapar University, Patiala

*Countersigned by:*

Head   
Electrical & Instrumentation Engineering Department  
Thapar University, Patiala

  
Dean (Academic Affairs)  
Thapar University, Patiala

## ACKNOWLEDGEMENT

It is a great pleasure for me to take this opportunity to express my profound sense of gratitude to all those who assisted me in the completion of this dissertation work.

I gratefully acknowledge my supervisor **Dr. Amrita Sinha** for her understanding, encouragement and personal attention which have provided good and smooth basis for my dissertation tenure. This work would not have been possible without her guidance, support and encouragement. Under her guidance I successfully overcame many difficulties and learned a lot.

I would also like to express my sincere gratitude to the **Technical Staff** of Electrical and Instrumentation Engineering Department, Thapar University, Patiala for thoroughly helping me with experimental work.

I am also thankful to **Dr. Prakash Gopalan**, Director of Thapar University, Patiala for providing the facilities for the completion of M.E. I express my deep sense of gratitude towards **Dr. Ravinder Agarwal**, Professor and Head of the Department of Electrical & Instrumentation Engineering, **Ms. Manbir Kaur**, Associate Professor, P.G. Coordinator, Electrical and Instrumentation Engineering Department, Thapar University, Patiala who has been a constant source of inspiration for me throughout this work.

I am also thankful to my batch-mates who devoted their valuable time for the successful completion of dissertation. I extend my gratitude to the researchers and scholars whose hours of toil have produced the papers that I have used in the dissertation.

Words are short to express my deep sense of gratitude towards my family members and friends for their encouragement, inspiration, emotional support and love. Finally, I bow to the **Almighty** who gave me strength to carry out this work with sincerity and dedication.

  
RAYEES AHMAD  
801341020

## ABSTRACT

Protection of transmission line equivalent model has been done by using microcontroller based quadrilateral relay. This relaying protection scheme protects the transmission line equivalent model from single line to ground (L-G) fault. The overall process is monitored by ARDUINO UNO board including ATmega328 microcontroller. The main reason for using the quadrilateral relay is that it has the valuable property of possessing the least tendency for mal-operation due to heavy power swings, arc resistance, fault resistance and overloads. Its characteristics can be designed to just enclose the fault area of the line to be protected. The determination of quadrilateral characteristics has been completed through software. The data acquisition system (DAS) includes instrument transducers (CTs and VTs), i to v converter, filters, phase shifter, zero crossing detectors, bridge rectifiers and sample and hold (S/H) circuits. The ATmega328 senses the voltage and current values to compute the impedance of the equivalent line model and then compares the measured value with the prespecified value. If the measured value exceeds the prespecified value the microcontroller issues a trip signal to the circuit breaker and hence isolates the unhealthy portion of the transmission line equivalent model from the rest of the line. A single phase series R-L equivalent model of the transmission line has been achieved by using four modules of inductance and resistance connected in series. The capacitance has been neglected for the test purpose. Each module represents 50 kms of transmission line and hence a total of 200 kms, where the first zone represents 100 kms, second zone extends upto 150 kms and finally the third zone represents 200 kms. By closing the switches at different points of the transmission line faults have been created at these points, with bus voltage maintained at 220 volts for the model. Current and potential transformers have been used to step down the level of fault signal to the electronic level. Input signals of current and voltage have been simulated using specially designed phase shifter, zero crossing detector and sample and hold circuits. The software developed for the determination of the characteristics has been stored in the memory of the microcontroller system and executed. The whole circuitry has been designed and developed on the hardware. The DAS has also been simulated using MULTISIM software.

## Table of contents

S.No.	Title	Page No.
1.	<b>Certificate</b>	i
2.	<b>Acknowledgement</b>	ii
3.	<b>Abstract</b>	iii
4.	<b>Table of contents</b>	v-vii
5.	<b>List of figures</b>	viii
6.	<b>List of tables</b>	ix
7.	<b>List of abbreviations</b>	x-xi
8.	<b>Chapter 1 Introduction</b>	1-8
	1.1 Overview	1
	1.2 Zones of protection	3
	1.3 Requirements of protection system	4
	1.3.1 Selectivity	4
	1.3.2 Reliability	4
	1.3.3 Speed	5
	1.3.4 Discrimination	5
	1.3.5 Stability	5
	1.3.6 Sensitivity	5
	1.4 Primary and back-up protect	5
	1.4.1 Relay back-up	6
	1.4.2 Breaker back-up	6
	1.4.3 Remote back-up	6
	1.5 Protective relays	6
	1.5.1 Electromechanical relays	6

	1.5.2 Static relays	6
	1.5.3 Numerical relays	7
	1.6 Adaptive relays	7
	1.7 Objective of the thesis work	7
	1.8 Organization of the work	8
		8
9	<b>Chapter 2 Literature Review</b>	9-17
10	<b>Chapter 3 Distance protective relaying</b>	18-22
	3.1 Overview	18
	3.2 Distance relaying protection of long transmission lines	18
	3.3 Three zone characteristics of a distance relay	19
	3.4 Problems of fault resistance in distance protection	20
	3.5 Commercial relay techniques and related problems	21
11	<b>Chapter 4 Quadrilateral relay</b>	23-34
	4.1 Overview	23
	4.2 Realization of quadrilateral characteristics	24
	4.3 Types of comparators for quadrilateral characteristics	25
	4.4 Advantages over other distance relay	28
	4.4.1 Arc resistance effect on the performance of the distance relays	28
	4.4.2 Reach of the distance relays	29
	4.4.3 Power swing effects on the performance of distance relays	31
	4.5 ARDUINO UNO R3 board	32
	4.5.1 Technical features of ARDUNO UNO board	33

	4.6 Working of ATmega328 Microcontroller	34
12	<b>Chapter 5 Implementation of quadrilateral relay</b>	35-43
	5.1 Current transformer	35
	5.2 Voltage transformer	36
	5.3 Low pass filter	36
	5.4 Rectifier	36
	5.5 Phase shifter and zero crossing detector	37
	5.5.1 Measurement of resistance	37
	5.5.2 Measurement of reactance	38
	5.6 Sample and hold circuit	39
	5.7 ARDUINO UNO board	40
	5.8 Functioning of proposed relay	40
	5.9 Experimental setup	41
	5.10 Circuit simulation model	42
13	<b>Chapter 6 Conclusions and future scope</b>	44
	6.1 Conclusions	44
	6.2 Future scope	44
14	<b>References</b>	45-49
15	<b>List of publications</b>	50
16	<b>Appendix</b>	51

## List of Figures

S.No.	TITLE	Page no.
1.	<b>Figure 3.1:</b> Quadrilateral characteristics of a digital distance relay	19
2	<b>Figure 3.2:</b> Stepped distance characteristics of digital distance relay	20
3.	<b>Figure 4.1:</b> Tripping characteristics of a quadrilateral relay	24
4.	<b>Figure 4.2:</b> Multi input phase comparator for quadrilateral characteristics	25
5.	<b>Figure 4.3:</b> Various characteristics resulting from phase comparison of inputs.	27
6.	<b>Figure 4.4:</b> Effect of arc resistance on distance relays	29
7.	<b>Figure 4.5:</b> Effect of power surges on distance relays	32
8.	<b>Figure 5.1:</b> Block schematic diagram of the proposed ARDUINO UNO based quadrilateral relay	35
9.	<b>Figure 5.2:</b> Program flow chart for measurement of R and X.	38
10.	<b>Figure 5.3:</b> Circuit diagram and corresponding waveforms of phase shifter and zero crossing detector.	39
11.	<b>Figure 5.4:</b> Schematic diagram of protection using relay with MOSFET.	41
12.	<b>Figure 5.5:</b> Protect setup of transmission line equivalent model.	41
13.	<b>Figure 5.6:</b> Waveforms of the bridge rectifier and S/H circuit.	42
14.	<b>Figure 5.7:</b> Simulation model of DAS.	43

## List of tables

S.No.	Tables	Page no.
1.	<b>Table 1.1:</b> Percentage distributions of faults in various elements of a power system	2
2.	<b>Table 1.2:</b> Frequency of occurrence of different types of faults on overhead lines.	3
3.	<b>Table 4.1:</b> The extent of under reach of different relays due to arc resistance	30

## List of Abbreviations

CB	Circuit Breaker
IEEE	Institute of Electrical and Electronic Engineering
L-G	Line to Ground
L-L	Line to Line
L-L-G	Line to Line Ground
3- $\phi$	3-Phase
DC	Direct Current
Z <sub>R</sub>	Replica Impedance
Z <sub>L</sub>	Line Impedance
X <sub>R</sub>	Replica Reactance
V <sub>L</sub>	Line Voltage
I <sub>L</sub>	Line Current
R <sub>arc</sub>	Arc Resistance
I	Current
CT	Current Transformer
VT	Voltage Transformer
ELD	Extra Long Distance
UHV	Ultra High Voltage
EHV	Extra High Voltage
DAS	Data Acquisition System
VLSI	Very Large Scale Integration

DSP	Digital Signal Processing
ANN	Artificial Neural Network
ZOR	Maximum impedance at which relay will operate with an offset current
ZSR	Maximum impedance at which relay will operate for symmetrical current
AC	Alternative Current
PWM	Pulse Width Modulation
USB	Universal Serial Bus
ADC	Analog to Digital Converter
LCD	Liquid Crystal Display
LED	Light Emitting Diode
S/H	Sample and Hold
MOSFET	Metal Oxide Semiconductor Field Effect Transistor

# CHAPTER 1

## INTRODUCTION

### 1.1 OVERVIEW

The capital investment involved in a power system for the generation, transmission and distribution of electrical power is so great that the proper precautions must be taken to ensure that the equipment not only operates as nearly as possible to peak efficiency but also that it is protected from accidents. The normal path of the electric current is from the power source through the conductors in the generators, transmission lines and transformers to the load and it is confined to this path by insulation. The insulation, however, may be broken down, either by the effect of temperature and age or by a physical accident, so that the current then follows an abnormal path generally known as short circuit or fault. Whenever this occurs the destructive capabilities of the enormous energy of the power system may cause expensive damage to the equipment, severe drop in voltage and loss of revenue due to interruption of service. Such faults may be made infrequent by good design of the power apparatus and lines and the provision of the protective devices, such as surge diverters and ground fault neutralizers, but a certain number will occur inevitably due to lightning and unforeseen conditions. The chances of fault occurring due to storms, falling of external objects on the lines, flashover resulting from dirt deposits on insulators etc. are greater for overhead lines than for other parts of the power system. Table 1.1 gives an approximate idea of the fault statistics. Also table 1.2 shows the frequency of occurrence of different types of faults on overhead lines.

The purpose of protective relays and relaying systems is to operate the correct circuit breakers so as to disconnect only the faulty equipment from the system as quickly as possible, thus minimizing the trouble and damage caused by the faults when they do occur. It would be ideal if the protection could anticipate and prevent faults but this is obviously impossible except where the original cause of a fault creates some effect which can operate a protective relay. So far only one type of the relay falls within this category, this is gas detector relay used to protect transformers. With all other equipments it is only possible to mitigate the effects of a short circuit by disconnecting the equipment as quickly as possible, so that the destructive effects of the energy into the fault may be minimized.

A protective system includes circuit breakers, transducers and protective relays to isolate the faulty section of the power system from the healthy sections. A circuit breaker (CB) can

disconnect the faulty section of the system only when it is called upon to do so by the protective relay. CTs and VTs are used to reduce currents and voltages to lower values and to isolate protective relays from the high voltages of the power system. The protective relay is a device which senses abnormal conditions on the power system by constantly monitoring electrical quantities of the systems, which differ under normal and abnormal conditions. The basic electrical quantities which are likely to change during abnormal conditions are current, voltage, phase angle and frequency. Protective relays in general utilize one or more of these quantities to detect abnormal conditions on the power system. The cost of a protective equipment generally works out to be about 5% of the total cost of the system except some cases where the equipment to be protected is costly and of more importance [11, [12]].

**Table 1.1: Percentage distributions of faults in various elements of a power system.**

Element	% of Total Faults
Overhead Lines	50
Underground Cables	09
Transformers	10
Generators	07
Switchgears	12
CTs, VTs, Relays, Control Equipments etc.	12
TOTAL	100

An extensively used protective relaying scheme for the protection of high, EHV/UHV, ELD and sub-transmission lines is the distance relaying principle due to their high speed fault clearance compared with the differential relays (over-current relays). Distance relaying provides a better way of detecting zone discrimination [38], selectivity and operation speed by confirming accurate trip decision upto a certain range of distance of a transmission line. From the perspective of hardware description, evolution of distance relays begins from electromechanical relays to static relays to numerical (digital) relays. While preserving their economic advantages numerical relays employing microcontrollers have become reliable,

faster and more powerful,. The versatile family of distance relay group include impedance relays, reactance relays, MHO relays, conic section relays and quadrilateral relays. Among these quadrilateral characteristic is best suited to EHV/UHV and ELD lines as it possesses an ideal distance relay characteristic. These characteristics can be designed to snugly fit the fault area of the line being protected. Power swing, fault resistance and overload effects on these characteristics are least.

**Table 1.2: Frequency of occurrence of different types of faults on overhead lines.**

Types of Faults	Fault Symbol	% of Total Faults
Line to Ground	L-G	85
Line to Line	L-L	08
Double Line to Ground	L-L-G	05
Three Phase	3- $\Phi$	02

Distance relaying techniques of transmission lines, over the recent years, has been given much more attention. Calculation of impedance at the fundamental frequency between the relay and fault point is the main purpose of the distance relaying techniques. Numerical relays which are based on numerical (digital) devices e.g. microprocessors, microcontrollers, DSPs etc. are the latest improvements in the power system protection network. Availability of influential, economical and sophisticated microcontrollers resulted in the development of microcontroller based protective relays that are more flexible, reliable, accurate and fast because of being programmable. This microcontrollers based distance relaying can be implemented for several characteristics with the existing hardware or with a slight change in hardware. These reduce the hardware complicity and cost to a greater extent.

## **1.2 ZONES OF PROTECTION**

Normally to protect the major power system components, a power system is categorised into a number of protective zones. The various components which belong to a protective zone include a transformer, a generator, a transmission line, a distribution line or a motor. In order to protect every portion of the power system under consideration there is an overlap between protective zones [11], [12]. Relays and circuit breakers (CBs) are included with every zone of protection, of the distance relaying system, in which at least one or more component is

present. To isolate the protected zone during unhealthy condition, while the rest of the system continuing to provide power to the consumers, the CBs are organised in a proper manner. In order to isolate the faulty zone on the power system, the protective system initially identifies the fault condition and then directs a trip signal to the appropriate CB [16]. Backup protection is provided in the adjoining zones so that the protective relays are exempted from the risk of failure. If a primary relay fails to isolate the unhealthy zone during abnormal conditions, a backup relay is used which not only isolates the unhealthy zone but also the adjoining zones connected to the unhealthy zone.

### **1.3 REQUIREMENTS OF PROTECTION SYSTEM**

The simple prerequisite of a protective system is to remove the fault with an adequate speed in order to minimize the severe effects of the unfaithful event. To fulfil this condition, a protective system must inhold the following properties [18],[27].

#### **1.3.1 Selectivity**

Selectivity is the quality of a protective relay to isolate only a faulty section of the power system from the remaining fine system. Selectivity is perfect if the protective system reacts only to faults which are present its zone. However selectivity is known to be comparative if it is attained by arranging the settings of protective system of various zones corresponding to a particular fault. In unit protective relays the selectivity is almost absolute, whereas the selectivity is relative in non-unit protective systems.

#### **1.3.2 Reliability**

Reliability refers to the capability of a protective system to perform correctly throughout the interval of its usage. Reliability of protective systems is evaluated from statistical data. The failure of a protective system may be due to the failure of any one or more elements of the protective system. To achieve a high degree of reliability greater attention should be given to design, installation, maintenance and testing of the various elements of the protective system. Robustness and simplicity of the relaying device also contribute to reliability of the system. With the increasing size of systems, the importance of reliability has increased to a greater extent.

#### **1.3.3 Speed**

A protective relaying system should be fast enough to segregate the faulty section of the system as quickly as possible so as to minimize the equipment damage and to maintain the stability. For modern power systems the stability criterion is much more important and hence the operating time of the protective relay should not exceed the critical clearing time to elude

the loss of synchronism. Hence, the faster the speed of operation of the relay the lesser is the damage to the power system components.

#### **1.3.4 Discrimination**

The protective relaying system should be selective towards faults and abnormal conditions beyond its protective zone. The protective relay must be able to distinguish between the faulty condition and the healthy conditions particularly. For example it must discriminate between a fault and unwanted conditions such as power surges or magnetising inrush of a transformer.

#### **1.3.5 Stability**

The ability of a protective relay due to which the protective system remains non-functional during certain particular conditions linked with faults beyond their tripping zone. Hence, it is to be concluded that the protective system must be stable against system disturbance, through faults, transients for proper functioning of the relaying system.

#### **1.3.6 Sensitivity**

A protective relay should operate when the magnitude of the current exceeds the preset value. This is pick up value of the current and relay must not function below its pick up value. For example, for EHV and UHV transmission lines high resistance faults are frequent in nature and the system must be capable of detecting such conditions before they grow into serious problems. Sensitivity can be defined in terms of sensitivity factor ( $K_s$ ) equal to the ratio of minimum short circuit current and minimum operating current.

### **1.4 PRIMARY AND BACK-UP PROTECTION**

Protection in a power system is mainly of two types, these include primary and back-up protection. The primary scheme acts as a first line of shield. However back-up protection acts as a second line of defence. The back-up protection scheme comes into action when the primary protection scheme could not operate. There are three types of back-up protection schemes as mentioned below [18], [27].

#### **1.4.1 Relay back-up**

Duplication of the normal relays, their CTs etc. would provide relay back-up without time delay because they would work in parallel. Relay back-up protection scheme is the expensive and complex. Though this scheme is costly it can be recommended where a remote back up is not possible and would be justified only on very important interconnections.

### **1.4.2 Breaker back-up**

This type of back up is also a kind of local back up .This is necessary for a bus bar system where many CBs are connected. When a relaying system functions in response to a fault yet a CB fails to trip, the fault is transformed into a bus bar fault. In breaker back-up scheme it becomes necessary that all other CBs should trip present on that particular bus.

### **1.4.3 Remote back-up**

This type is the simplest and the cheapest form of back-up protection and is most widely used back-up protection for transmission line. When the back-up relays are located at the nearby station, they back-up the entire primary protective scheme in case of any failure. This form of back-up protection scheme is the most widely used one.

## **1.5 PROTECTIVE RELAYS**

Protective relaying systems have underwent through main improvements because of the revolution in technology. Electromechanical relays are the first of its type in the protective relay family which served the system in a suitable and reliable manner. Because of the advancements in VLSI techniques, solid-state relays came into existence [30]. Minimum dimensions and smooth action are the major benefits of the static relays over the previous electromechanical relays. Technology based on microcontrollers and DSPs [10], made the relaying systems even more feasible, smoother, multi-tasking and supple. Relays which are using digital technology are known as digital/numerical relays [34], [36],[ 37].

### **1.5.1 Electromechanical relays**

These were the first types of devices used to protect the power system components. As per application they have been in service for quite a long time in history. These are working on the principle of either electromagnetic attraction or electromagnetic induction. These types of relays inhold many significant properties such as large torque, high operating speed, robustness, reliability and invulnerability to transients. Since these devices include moving parts friction, high burden and high power consumption are the main problems associated with these relays [27],[ 29].

### **1.5.2 Static relays**

The term static relays is generally referred to a relay incorporating solid state components such as transistors, diodes, resistors, capacitors etc. In this type of relay the functions of comparison and measurement are performed by static circuits which include no moving parts. These were first developed in 1950s using solid state components. With the rise of power systems the need for more sensitive and faster protection schemes became essential. The

arrival of semiconductors overcame the supply problems associated with thermionic valves. It should be clearly understood that it is not usually economical to replace existing electromechanical relays with their static counterparts just to reduce maintenance, source gain in technical performance should also be. The use of static relays in general reduces the burden on the current transformers and also includes high speed of operation, reliability, immunity to vibrations, weight reduction and miniature size. However static relays are costly as compared to the electromechanical relays. Moreover these are affected by transient conditions, which, if present in the inputs would result in malfunctioning of these relays [27], [40].

### **1.5.3 Numerical relays**

Numerical relays are the modern improvement in this era. These relays acquire the sequential samples of the ac quantities in digital form through the data acquisition system and process the data numerically using an algorithm to determine the fault discriminants and finally making the trip decisions. Numerical relays have been developed due to tremendous advancements in VLSI and computer hardware expertise. The present downward trend in cost of VLSI circuits has encouraged wide application in of numerical relays for the protection of modern power systems [11]. These are based on numerical devices such as microprocessors, microcontrollers, digital signal processors (DSPs) etc. Currently microprocessor/microcontroller based protective relays are used widely. These relays use different relaying algorithms to process the acquired information. Numerical relaying has become a viable alternative to the traditional relaying systems employing electromechanical and static relays. Intelligent numerical relays using artificial intelligence techniques such as Artificial Neural Networks (ANNs) and Fuzzy Logic Systems are presently under research and development stage.

The key attributes of numerical relays are their economy, compactness, flexibility, reliability, multiple functions, less burden on instrument transformers and enhanced performance over conservative relays of electromechanical and static types.

## **1.6 ADAPTIVE RELAYS**

Adaptive relaying constitutes the latest trend of protective relaying technique. In this philosophy continuous varying status of the power system is employed as the source for online regulation of the numerical relay settings. It provides the essential flexibility for achieving improved level of reliability [3], [4], [33].

The adaptive approach of determining system settings and upgrading the ideal trip conditions proves to be very useful. Voltage and current samples are determined by the adaptive algorithm at the location of the relay. After this the apparent impedance is determined and compared to the recent trip boundaries for the occurrence of a fault and its locations [3]. But this trend imposes new problems in creating numerical algorithms that provide adaptability to the variations in system constraints. DyLiacco [45] was the first to propose the method of refining the digital relay settings as per the varying system parameters. Horowitz and Phadke [11] represented adaptive relaying as a protection viewpoint in order to make it more adjusted to prevalent power system conditions. Haj-ahmed and Illindala [17] too suggested an analysis in the use of adaptive settings for enhanced distance back-up protection. In the same way a variety of definitions of adaptive relaying have been given by the different researchers [4], [5], [7], [13], [20], [21]. These definitions define the similar details in diverse ways. With the assistance of numerical relays the adaptive relaying philosophy can be made fully productive.

### **1.7 OBJECTIVE OF THE THESIS WORK**

The thesis reports a single line to ground (L-G) fault that occur on the transmission line equivalent model and further involve design and implementation of a highly efficient microcontroller based quadrilateral relay for the protection of the transmission line. The main objective of the thesis is to design a low cost, reliable and highly effective protection scheme for the protection of transmission line equivalent model which represents a 200km long line. Further to extend the scheme for three phase faults.

### **1.8 ORGANIZATION OF THE WORK**

The thesis is organized in six chapters. The contents of these chapters are as follows:

Chapter 2 discusses the literature survey about the thesis work.

Chapter 3 summarizes the protective distance relaying for L-G fault of the transmission line.

Chapter 4 discusses the importance and characteristics of the quadrilateral relay.

Chapter 5 employs the implementation of the microcontroller based quadrilateral relay.

Chapter 6 summarises the conclusion of the work.

## **CHAPTER 2**

### **LITERATURE REVIEW**

On a transmission system the protective relaying system is incorporated to detect the abnormal signals indicating faults and isolate the faulted part from the rest of the system with minimal disturbance and equipment damage. Literature reveals that protective relay is required to satisfy six basic functional characteristics viz reliability, selectivity, speed, stability, discrimination and sensitivity.

In this chapter research work related to different procedures of protection of EHV and UHV transmission lines is presented as reported by different authors.

Rockefeller G.D. [1] was the first to introduce the digital computers in the area of the protection of power systems. The author developed a fundamental basis for the use of a time-shared stored-program digital computer to perform many of the electrical power-system protective-relay functions in a substation. Logic operations were given to detect a fault, locate it, and initiate the opening of the appropriate circuit breakers, whether the fault is in the station or on lines radiating from the station. The instantaneous values of the station voltages and currents were sampled at a 0.5-ms rate, converted to digital form, and stored for computer main-frame use. Operating times were compatible with the 25-ms breaker trip capability of modern two-cycle breakers. Computer speed in initiating tripping has a maximum value of 4 ms for severe faults and a maximum of 10 ms for moderate or distant faults. The following salient advantages to the use of a computer are foreseen:

- Faster breaker tripping, with security against undesired operations comparable to existing relays (the logic here provides 4-ms nominal trip time).
- Greater dependability, since the hardware is in frequent use as contrasted to the protracted idleness of existing hardware.
- More economical; cost can be shared with non-protective functions for data acquisition and control.
- Readily adaptable to use with digital current and potential transducers.

Vitins M. [2] described a fundamental approach for detecting the direction to a power system fault within the first milliseconds following the fault inception. The method is based on a combined evaluation of the voltage and current deviations generated by the fault occurrence. The method solves several problems occurring in conventional relaying and is suitable for

use in ultra-high speed protection systems which employ a fast telecommunication channel between the ends of the protected network.

The method is suitable for use in high speed directional comparison schemes and in applications where different redundant operating principles are desired. The inception of a fault in a power system is represented by a trajectory which characterizes the voltage and current changes due to the fault occurrence. A geometric approach is discussed to extract information on the fault location from the fault trajectory. Factors which influence the shape of the trajectories are described and verified by numerical simulations and by experiments on a transient network analyser.

Zhizhe Z. and Deshu C. [3] presented an adaptive principle and methods in digital distance protection. Three adaptive methods have been suggested to deal with the following problems: (1) effect of frequency variation, (2) effect of fault resistance in single-phase to ground faults, and (3) effect of power swings. In order to verify the feasibility of the adaptive methods, a prototype digital distance protection with some adaptive functions has been designed and tested on a 500 kV dynamic power system model. The test results showed that the performance of the digital distance protection can be improved by use of the adaptive methods.

Mechraoui A. and Thomas D. W. P. [4] presented a new blocking principle with phase and earth fault detection during fast power swings that has the ability to immediately clear the block when a fault occurs within the relay trip zone. This is demonstrated for extremely fast swings (greater than 5 Hz/sec) and even for two phase operation (during single pole tripping). The proposed principle is compatible and can be implemented with the existing digital distance protection relay. The proposed scheme operation was demonstrated on simulated transients using the EMTP program. The clearance of power swings has proved to be problematical for high resistance faults (100-200 ohms). However, even if blocking is cleared a radically different adaptive distance scheme will be needed to adjust the measured impedance during high resistive faults. Further work is being carried out to see if high resistance faults (100 – 200 ohms) can also be detected during power swings.

Magnago F. H. and Abur A. [5] described the use of wavelet transform for analysing power system fault transients in order to determine the fault location. Traveling wave theory has been utilized in capturing the travel time of the transients along the monitored lines between the fault point and the relay. Using the traveling wave theory of transmission lines, the transient signals are first decoupled into their modal components. Modal signals are then transformed from the time domain into the time-frequency domain by applying the wavelet

transform. The wavelet transform coefficients at the two lowest scales are then used to determine the fault location for various types of faults and line configurations. The proposed fault location method is independent of the fault impedance and is shown to be suitable for parallel transmission lines as well as series capacitor compensated lines. The method can be used both with single ended and synchronized two ended recording of fault transients. The fault location estimation error is related to the sampling time used in recording the fault transient.

Eissa M. M. and Masoud M. [6] discussed problems associated with parallel line distance relaying schemes and presented a novel technique to overcome these problems. Two relays were proposed instead of four for the double lines one at the beginning and another one at the end. The suggested method was based on the comparison of the measured impedance of corresponding phases. So, the complexity of the possible types of faults, high path fault resistance, mutual effects, current in-feed, inter-system faults are solved. The technique was tested under different fault types, high fault resistances, fault inception angles and fault locations. The tripping time was recorded by 10 ms for all types of faults in the first zone. For faults located at second zone or at the remote end the relay will trip after a certain time delay. The reliability, great selectivity and high speed were the main points featured in the proposed technique.

Wu et al. [7] presented a novel ultra-high-speed directional protection scheme developed using mathematical morphology (MM). The MM technique proposed is used to extract transient features from fault-generated voltage and current signals propagating along transmission lines during a post-fault condition. Fault direction is determined by two composite relaying signals which are composed of the extracted transient features. The proposed method possesses the following advantages:

- A short data window with eight sample points covering a period of 8  $\mu$ s at a sampling rate of 1 MHz is required in this case. It is much shorter than that used in the Wavelet transform analysis.
- Fast calculation can be undertaken with only addition, subtraction, and comparison operations involved, in contrast with the integral transform methods (e.g., Fourier and Wavelet transform), which require more complex computation.
- The MM technique provides the excellent capability of extracting the transient features of fault waveforms as well as their polarities exactly and indicating sudden changes of the waveform accurately.

Dong et al. [8] proposed a new directional relay based on travelling waves referred to as the surge impedance relay (SIR). The relay used both the polarity information and magnitude information of the travelling waves in order to ensure the reliability of the relay. Furthermore, the SIR algorithm adequately utilizes the different frequency information in its multi scale criteria based on wavelets, making the SIR more reliable. The results of EMTP simulations showed that the relay could work correctly in the majority of fault types and conditions. But the relay cannot identify the fault and the lightning, nor can it identify the fault and breaker operation by itself.

Zou et al. [9] proposed an improved fault phase selector for an unbalanced fault during a power swing by utilizing the series multiresolution morphological gradient (SMMG) transform to extract the superimposed components of modular currents. The theoretic analysis and the simulation results enable the following outcome.

- The superimposed currents can be effectively and rapidly extracted during the power swing condition by SMMG; hence, the proposed phase selection scheme has satisfactory responding speed, sensitivity, and reliability.
- The SMMG-based phase selection schemes are able to cope with large ground fault resistances.
- The fault location and fault inception angle have little influence on the phase selection approach.

Darwish H.A and Fikri M. [10] addressed possible recursive DFT error accumulation in numerical relays. Capturing these accumulated errors has been experimentally introduced and a valid scenario for their occurrence has been proposed. The experimental results are corroborated using an equivalent Simulink model. Six alternative solutions for accumulated error elimination have been proposed, evaluated, and the optimized DFT expression has been elected. The test results revealed that the proposed optimized parallel DFT should be considered for modern computer relaying practices, as new hardware tends to utilize the powerful float-point microcontrollers and DSPs.

Lin et al. [13] proposed a fast unblocking scheme for distance protection to identify symmetrical faults occurring during power swings, based on the change rates of three phase active and reactive powers. The proposed method improves the sensitivity and the response of distance protection when a three-phase symmetrical fault occurs during power swings. The simulation results showed that the aforementioned scheme has the following advantages.

The distance protection can be blocked reliably during any stages of power swings. When symmetrical faults occur, the criterion can unblock the protection rapidly. It is superior to the existing schemes based on a single characteristic variable.

The criterion is proved not to be affected by factors, such as system parameters, fault time, fault position, and so on.

This scheme can be easily implemented on existing microcomputer-based relay protection hardware.

Xu et al. [14] described a new digital Bergeron distance protection relay scheme based on the distributed parameter model of a 1000-kV UHV transmission line. A linear relationship between the fault distance and the measured Bergeron impedance is derived for different types of fault. The effect of the distributed capacitance along the line has been taken into account and the measured per phase impedance for a solid fault is simply the series impedance of per unit line length multiplied by the distance to the fault. The proposed scheme has been extended to situations with in-line shunt compensation reactors. With the transient error less than  $\pm 5\%$ , the proposed Bergeron distance relay can be used in the pilot distance protection and back up distance protection schemes for a long 1000-kV UHV transmission line.

Harikrishna M. [15] explained factors impacting performance of Quadrilateral relay focusing on accuracy and speed of operation. Designed Quadrilateral relay system and Bergeron model type transmission line and simulated using PSCAD/EMTDC analysis software to study the different type of fault at various fault resistances. A Fast Fourier technique has been used to generate apparent impedance. Quadrilateral characteristics true for providing high resistance coverage during single phase to ground faults. It provides protection coverage in second quadrant during two phases to ground faults and three phases to ground faults. The simulation result showed Quadrilateral relay are highly suitable for protection of extra high voltage transmission line during resistance faults and also overcomes over reach problem. The mentioned scheme improved the sensitivity and reliability.

Saravanababu et al. [16] proposed a novel technique for the protection of transmission lines. The proposed system used Discrete Wavelet Transform (DWT), which is widely used in recent times for power system protection, to extract the hidden factors from the fault signals by performing decomposition at different levels. Daubechies wavelet “dB6” is used with single level decomposition and adaptive threshold is calculated to discriminate and detect the faulty phase. The location of faults is carried out by obtaining the local fault information and remote location fault information along with the transmission line length. The system is

independent of any statistical system data and has negligible fault resistance. The proposed system promises the result by detecting, classifying and locating all the ten faults possible in the transmission line of the power system.

Haj-ahmed M. A. and Illindala M. S. [17] presented a novel multi-agent system (MAS) based methodology for power system protection. Various system agents are designed to collaborate and adaptively modify the setting of distance relay zone 3 via communication with neighbouring substations. The proposed coordination scheme aids in preventing fault mis-judgment and possible network break down because of load encroachment. The proposed scheme mitigated the malfunction of distance relays in the presence of power system instabilities including load encroachments by enabling or disabling third zone settings. It has been proven that the proposed MAS based distance relaying scheme has a superior response as compared to the traditional distance relay with Mho or reactance settings. In addition, the proposed scheme enhances the relay selectivity by making it capable of distinguishing between a symmetrical fault and very low impedance faults. Furthermore, it enhances the relay selectivity and loadability.

Ravishankar K. and Thukaram D. [19] developed the distance relay characteristics for UHV and EHV transmission lines using Electromagnetic Transients (EMT) simulations. UHV distance relay characteristics are seen to be much different from that of EHV system because of high shunt capacitance of long UHV line. The variations of ideal trip boundaries for both the systems are presented. Here distributed parameter model has been used. The effect of larger shunt susceptance on the trip boundaries is presented. Two practical transmission systems of Indian power grid, namely 765 kV UHV transmission line and SREB 24-bus 400kV EHV system are used to test the performance of the proposed approach. Trip boundaries of 765kV UHV transmission line compared to 400kV EHV line are much different in nature because of high shunt capacitance. The trip boundaries computed under different conditions will be useful for EHV/UHV digital relay trip decisions. An improved full cycle DFT algorithm to estimate and eliminate the decaying DC component in fault current signal is used.

Sachdev M. S. and Baribeau M. A. [20] used least error squares approach to compute the real and imaginary components of voltage and current phasors. Impedances as seen between the relay location and fault point are then calculated. The concept of pseudoinverse which has been used in developing the algorithm is also presented. The proposed algorithm was tested using the fault data recorded at the Regina South switching station of the Saskatchewan Power Corporation.

Wu J. K. et al. [21] presented a scheme for eliminating the dc component and non-period component with exponential decay using central numerical differentiation with 11 points and DFT out of the non-sinusoidal post fault signals of the power system. DFT has been used to estimate the time constant of non-period signals and numerical differentiation to eliminate the dc components and to estimate the amplitudes and phase angles of non-sinusoidal post fault signals. The proposed algorithm can be applied to digital power metering and digital protection relaying.

Li S. et al. [22] studied the performance of a 3 zone impedance relays (MHO relays) during unstable low power frequency swings by a polynomial function to measure the critical swing angles and critical swing frequency with different relay settings and found the contributing factors leading to relay operation. Despite of the lengths of swing loci, the swing angles are more densely populated inside than outside of the protection region, and the residence time may be long enough to activate the relays. Unwanted operation more possibly occurred for relays with shorter time setting and under low swing frequency.

Pang C. and Kezunovic M. [23] introduced a high speed symmetrical fault detection method for transmission lines during power swing conditions, which aimed at avoiding possible relay misoperations. It extracts the traveling waves from transient signals induced by faults and calculates the energy of high frequency components extracted by using the wavelet transform. The proposed scheme is very fast. It could detect the fault within 3 ms after the symmetrical fault occurs during the power swing, which could be beneficial for system protection, especially in the EHV system. The proposed method can be used for distance relay operation blocking or monitoring.

Warathe S. and Patel R. N. [24] proposed a modified algorithm for numerical relay (MHO relay) embedded with digital signal processor (TMS320F2812) to protect the transmission line from power swing disturbance and avoid the unforeseen blackout. They carried out their work by taking two equivalent Indian regional grids connected with tie lines to simulate the model for 25.0 seconds and the effect of loss of generation at time 10.0 seconds on distance protection because of power swings. The relay measured the apparent impedance which was in zone 3 of protection and relay tried to issue the trip signal but the modified algorithm analysed the signal and issued the blocking command to circuit breaker for power swing. The proposed algorithm is working properly and discriminate the faulty condition and power swing condition and issuing the block signal or trip signal based on logic.

Engler F. et al. [25] described an ultra-high speed directional comparison relay based on the evaluation of transient signals generated by faults for fault detection for EHV/UHV

transmission line protection. The relay processes transient signals which together with the simultaneous application of a differentiating and an integrating algorithm enables line faults to be detected extremely fast and reliably. The signal processing were performed by three microprocessors, one for each phase, however the other logical functions were performed by fourth microprocessor.

Hashemi S. M. et al. [26] presented a fast speed directional comparison protective scheme for transmission lines, involving the average value of superimposed components, which approximately equal to zero during normal operating conditions and non-zero during faulty conditions. The fault is detected by communication between the local and the remote relays. The above mentioned scheme considered impact of important parameters, such as fault location, fault inception angle, fault resistance and noise-polluted fault signals on the protection systems. The obtained simulation and experimental results have shown that the efficacy of the proposed method in detection of line faults is less than a half cycle.

Xia Y. Q. et al. [28] described the digital implementation of the phase angle comparators, which makes use of fundamental frequency components of the compensated voltages. Based on this principle, a highly reliable digital directional relay has been developed which possesses a stable and distinct directional discrimination to various faults under different fault conditions. It is also able to maintain its reliable characteristic even if fault occurs during power frequency variation and power swings.

Shunmugasundaram A. et al. [30] developed a static distance relay with conic characteristics which reduce the operating characteristics of the protective relay outside the fault area, so that the tripping on power swings is much less as compared with the conventional MHO units. The conic relay functions satisfactorily and besides being smaller in size and lighter in weight, the unit is more reliable than that of an equivalent electromagnetic type of relay used for the EHT line protection. With two inputs, impedance relay characteristics were achieved with the same unit.

Sreeram M. and Raja P. [31] implemented three step distance relaying protection of transmission line using MHO relay characteristics, simulated using PSCAD software considering a typical 220 kV transmission line. The hardware of the same relay has been implemented by using DSP TMS320F2812 and the DSP coding has been done using CCS3.

Hu Y. et al. [33] described the development of adaptive distance relay for the protection of parallel transmission lines including mutual coupling, fully compensated by zero sequence current of parallel transmission line if present and if not present then line operating status comes into play to select the zero sequence current compensation factor in impedance

calculation. However if neither is present then default compensation factor is used. For the 3 zone protection the quadrilateral trip characteristics with directionality feature has been developed. The results of extensive comparative evaluation prove the efficacy of the new adaptive relay over the conventional distance relay.

Sengupta S. and Mukhopadhyay A. K. [34] developed a microprocessor based high speed relay for protection of parallel EHV/UHV lines that operates within one quarter of a cycle but utilizing only the current signals making the system a single input one. Since the developed scheme has been based on waveform comparison approach, asymmetry of waveform has no effect on the operation of the scheme. Accuracy, speed of operation and reliability has been enhanced by the application of microprocessor. Also hardware minimization has been achieved to a greater extent.

Fischer D. and Beresh R. [35] presented a microcontroller based design of a very low cost numerical (impedance) relay, easily extendible to a mho or quadrilateral characteristic. A change of algorithm allows the implementation of an under/over frequency relay as well. DFT has been used to compute the impedance phasor from the two input signal phasors.

Gartia A. et al. [36] presented the differential protection for transmission line from internal faults using fibre optic communication based on voltage differential protection, where microcontroller compares received signal with the reference signal, easily extendible to current differential protection through voltage to current conversion. A working model was designed that employs microcontroller and fibre optic communication for the differential protection of line. Any received value below the threshold is an indication of internal fibre damage. Differential current beyond a fault current threshold value indicate the fault in the transmission line.

Shrivastava K. and Vishwakarma D. N. [37] presented a microcontroller based numerical quadrilateral relay for transmission line protection, employing algorithm based on Block Pulse Functions for the extraction of fundamental frequency components from the corrupted post fault signals. The accuracy of the fundamental frequency component extraction from the post-fault relaying signals is not affected by the distortions caused by changes in the fault inception angle. By employing the same interfacing circuit overcurrent and numerical differential protection of transformer and generator can be done.

## CHAPTER 3

### DISTANCE PROTECTIVE RELAYING

#### 3.1 OVERVIEW

Present power systems imply big total of expenditure on protection schemes. An electric power system comprises of generation, transmission and distribution of electric energy. Enlargement of power systems has resulted in strong complex structures stretched over vast distances. Under these conditions healthy functioning of the transmission lines decides the satisfactory operation of modern power systems. Present EHV and UHV lines are vulnerable to unreliable climate. Hence they are more prone to various types of hazardous climatic conditions resulting in faults. Therefore for better working of the power systems the faults must be detected and isolated quickly so that the instability of the power system due to prolonged faults may not happen which would further result in partial or complete shut-down of the power system networks. However the effects of the faults can be reduced to a large extent by working the power network in a suitable way and employing advanced protective relaying technology.

Numerical distance relays are generally employed for the protection of long EHV/UHV and ELD transmission lines. Normally, a conventional digital distance relay processes voltages and currents of the proposed transmission line to deduce the fault impedance and makes the circuit breaker to trip provided the fault impedance is less than the prespecified impedance. However, the fault resistance determined by the digital distance relay in case of a single line to ground (L-G) fault is not proportional to the impedance of the faulted portion of the line because of the presence of faulted path resistance.

#### 3.2 DISTANCE RELAYING PROTECTION OF LONG TRANSMISSION LINES

Distance relaying protection method is usually applied to safe guard long transmission lines against unhealthy conditions. Distance protection represents the primary protection for overhead transmission lines and affords back up protection to the attached parts of the system viz bus-bars, generators, transformers etc. As compared to overcurrent protection, distance protection provides faster and more selective operation. Further it is less vulnerable to variations in the power system parameters [6], [12].

The main function of a distance relay is to calculate the fault impedance [41] of a transmission line from the fundamental components of voltage and current after the fault has occurred. The calculated fault impedance is then related with the prespecified impedance of the transmission line under protection and if the calculated value exceeds the prespecified

value fault will be declared on the transmission line. From this it is concluded that the distance relaying protection in its modest way concludes the protection decision from the calculated values of voltage and current after the fault has occurred [18], [39].

### 3.3 THREE ZONE CHARACTERISTICS OF A DISTANCE RELAY

In present day world, digital/numerical distance relays with quadrilateral characteristics are favoured to safeguard EHV and UHV transmission lines. In recent numerical distance relays stepped distance characteristics are used to provide the back-up protection. Each distance relay is prespecified for three diverse zones of protection to shield a particular portion of a transmission system in distance relaying protection scheme [31], [38]. Fig. given below shows a distance relay with three zone quadrilateral characteristic. Further, the three zones of protection of the transmission line network are shown in Figure 3.2.

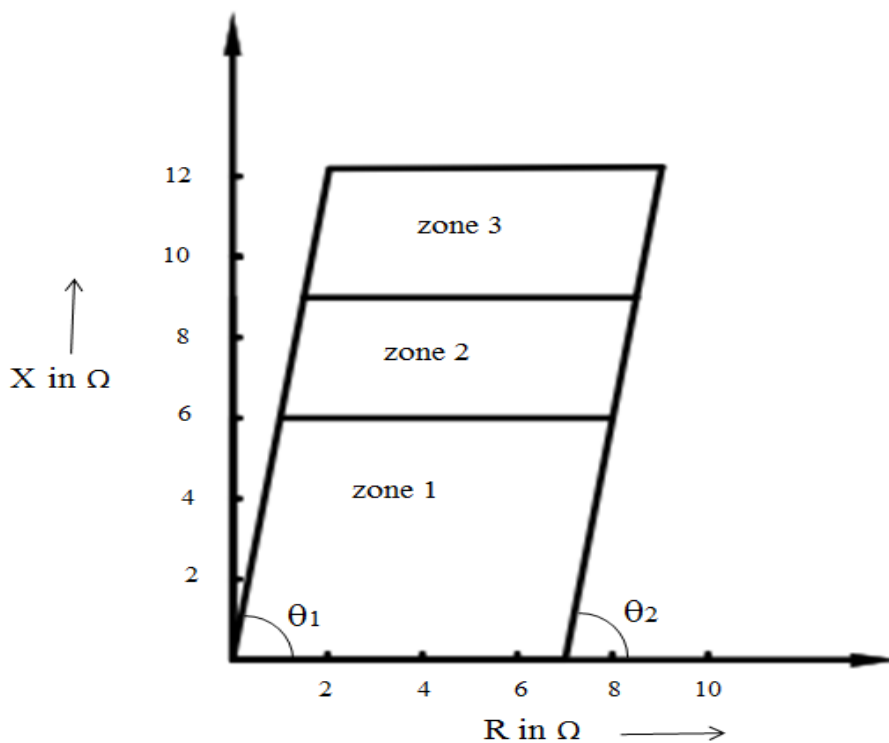
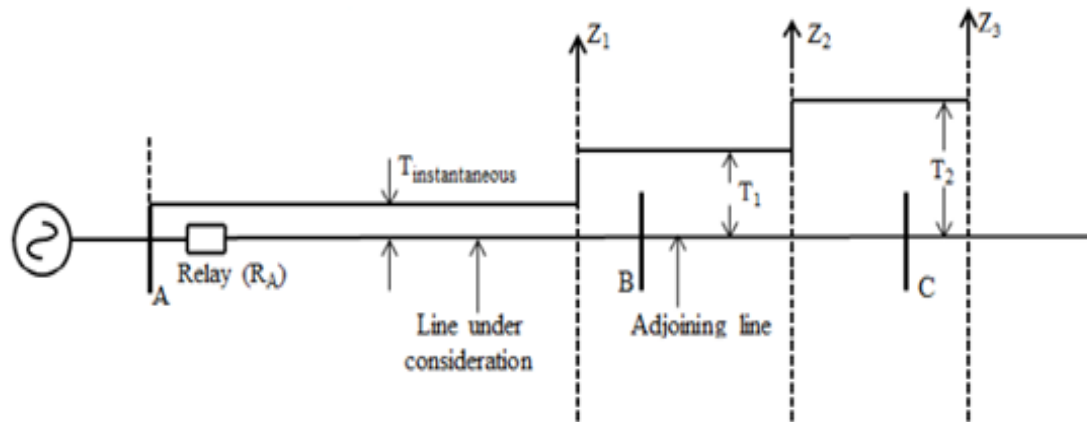

Figure 3.1: Quadrilateral characteristics of a digital distance relay

A numerical distance relay provides primary protection to the transmission line by covering about 80% to 90% of the transmission line length in its first zone, which is also regarded as high speed zone. The reason for not going to cover the 100% of the line is because of the transient overreach problem, errors in the CT's, PT's and errors in the relay itself in order to elude overreaching of the relay in the next section of the line to be protected. Thus in order to provide protection to the rest of the line second and third zones of protection are provided to the numerical distance relays [12], [19].

Numerical distance relays in their second zone of protection covers the complete section in addition to about 50% of the succeeding transmission line section. Generally, for a distance



**Figure 3.2: Stepped distance characteristics of digital distance relays.**

relay to perform in its second zone of protection a time delay of about 0.2 s to 0.5 s is provided [11], [12].

Now, the final or third zone of protection of a numerical relay provides protection to the complete first and second line sections. There is synchronisation between the third zone and the second zone of protection with respect to distance and time. For a numerical relay, in its third zone of protection the operating time is about 0.5 s to 1 s [18].

### **3.4 PROBLEMS OF FAULT RESISTANCE IN DISTANCE PROTECTION**

In case of numerical distance relays the fault under consideration is assumed to be ideal (i.e., negligible or zero fault resistance) while developing the relay equations [3]. As a result of which the relay calculates the fault impedance, analogous to the length of the line which is to be protected. However there is some limited value of fault resistance associated with the phase and ground faults. The fault resistance in case of single line to ground (L-G) fault includes arc resistance, tower footing resistance and resistance of ground. While arc resistance consists of only the fault resistance in line to line (L-L) fault. It is because of this fault resistance there is an initiation of an error while measuring the fault resistance and further this leads to unpredictable operation of a conventional numerical relay [34]. Following are the cases of severe concern,

- (a) Faults occurring near the relay point (close-in faults).
- (b) Faults occurring at the far end of the protected zone (remote end faults).

The reactance consequence appears as an impedance deviation in case of remote end faults of the transmission line. Such an effect may result in wrong operation of a numerical relay. Normally the arc resistance in case of numerical distance relaying is considered to be constant. However it increases with time due to elongation of arc channel and is represented by an empirical formula [12] as given below,

$$R_{ar} = \frac{76V^2}{S_{sc}}$$

Where,  $V$  = system voltage in kV

$S_{sc}$  = short-circuit kVA at the fault location

### **3.5 COMMERCIAL RELAY TECHNIQUES AND RELATED PROBLEMS**

For minimising the effect of disturbance and equipment damage in power system there is an important role played by the protective relays. These detect, locate and classify faults and accordingly isolate the faulted zone from the remaining system by sending suitable trip signals to the CBs. Most of the transmission system protective relays have been designed with distance protection. In order to determine whether the line to be protected is under fault or not, impedance measurement plays an important role [37].

For computer based protection of distance relays, till date numerous research articles have been published in literature [1], [3], [20], [34], [36]. Goldberg [1] was the first to perform this noble task of computer relaying. In recent years lot of research based on fault location methodology for extra high voltage lines has been done [5], [13], [15], [45]. A new technique has been presented by Sachdev and Baribeau [20] in which they determine the fault impedance by using the data from local end and remote end. Considerable errors have been reported for certain fault locations in the above said technique. However, there should be an explicit estimation of fault location. For EHV/UHV transmission lines based on distributed parameter model a new fault location algorithm has been presented by Magnago and Abur [5], which concludes that the fault path is wholly and solely resistive. At the sending end of a transmission there is a fault resistance compensation technique proposed by Eissa and Masoud [6] for a ground distance relay. In the proposed technique the risk of over-reach may increase because of the fault resistance path, although it has almost avoided under-reach which includes the load effect. Richardson and Tan [46] presented a substitute procedure in which optimization methodology involving voltages and currents at one local end has been

used to locate the faults. The said technique is very powerful but there is a problem of complexity in terms of requirement of an explicit model of the network and iterative calculations.

### QUADRILATERAL RELAY

#### 4.1 OVERVIEW

With the tremendous developments in VLSI and computer hardware technology, microprocessors that appeared in the seventies have evolved and made remarkable progress in recent years. Fast and sophisticated microprocessors, microcontrollers and digital signal processors (DSPs) are available today at low prices [11]. The application of these devices to power system protection have resulted in the availability of compact, quicker, more precise, flexible and reliable protective relays, as compared to the conventional ones. Numerical relays which are based on numerical (digital) devices e.g. microprocessors, microcontrollers, DSPs etc. are the latest development in the protection of power system networks. In numerical relays, the analog current and voltage signals monitored through CTs and VTs are conditioned, sampled at specified instants of time and converted to digital form. Thus numerical relays having monitored the current and voltage signals through transducers obtain the sequential samples through the data acquisition systems and execute the data numerically using an algorithm to determine the fault discriminants and finally making the trip decisions [31]. Considerable cost-benefit enhancement ensues because of the non-stop reduction in digital circuit costs and increases in their functionality. At present microprocessor/microcontroller-based numerical relays are widely used. There is a growing trend to develop and use numerical relays for the protection of various components of the modern complex power system. Numerical relaying has become a possible substitute to the traditional relaying systems employing electromechanical and static relays. Artificial intelligence technique based numerical relaying systems such as artificial neural networks (ANNs) and Fuzzy Logic Systems based numerical relays are presently under active research and development stage. The main features of the numerical relays are low cost, compactness, flexibility, consistency, self-monitoring capability, adaptive capability, multiple functions, metering and communication facilities, low burden on transducers (instrument transformers) and enhanced performance over conventional relays [12]. The least tendency for failures due to heavy power swings, fault resistance and overloads of a quadrilateral relay makes it is well suited for the protection of EHV/UHV and ELD transmission lines. It possesses an ideal distance relay characteristic. Its characteristic can be designed to snugly fit the fault area of the line to be protected. It is also suitable for short and medium transmission lines. The

electromagnetic version of this relay requires four units, each corresponding to one side of the quadrilateral, or a MHO relay with two blinders. A static relay employing a multi-input comparator gives a better quadrilateral characteristic than an electromagnetic relays [27]. But this relay doesn't contain the flexibility needed for obtaining different characteristics. A microprocessor/microcontroller based scheme can easily obtain a quadrilateral characteristic using the same interface which is used for other type of distance relays. It has the flexibility to obtain desired quadrilateral characteristics by simply providing the proper data. Quadrilateral characteristics are shown in the figures 4.1.

#### 4.2 REALISATION OF QUADRILATERAL CHARACTERISTICS

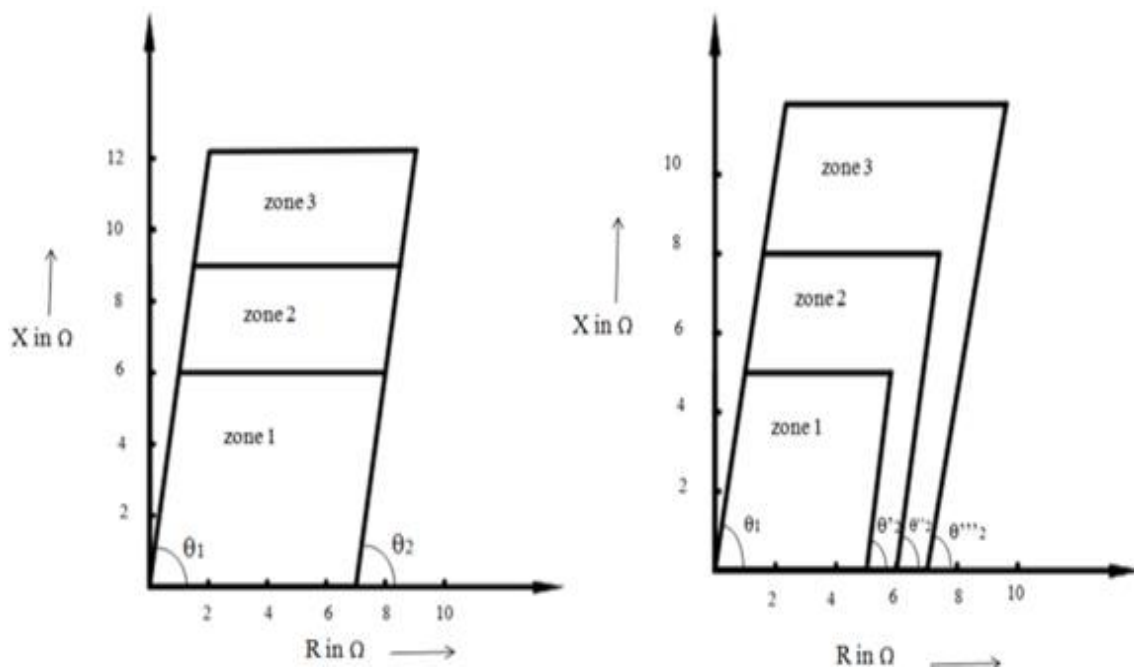
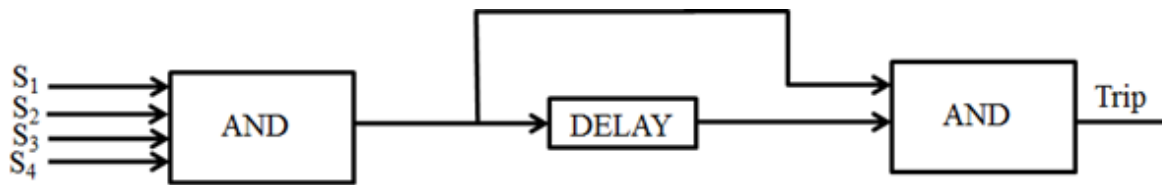

Figure 4.1: Tripping characteristics of a quadrilateral relay.

To realise a quadrilateral characteristic or any other multilateral characteristic, a multi-input phase comparator, as shown in figure 4.2, is employed [37]. There are more than two inputs



**Figure 4.2: Multi-input phase comparator for quadrilateral characteristics.**

in a multi-input comparator. If more than one two-input comparators are used to realise a complex characteristic, the relay will be faster than a single multi-input comparator. But the disadvantage of the combination of two-input comparators is that the outcome of each comparator do not activate simultaneously. In order to overcome this difficulty, the output of each comparator has to be extended for a short time which often leads to unpredictable tripping. In a multi-input comparator, all the input signals are compared with each other. The resultant characteristic is the area enclosed by the lines and circles resulting from all these comparisons [27].

### 4.3 TYPES OF COMPARATORS FOR QUADRILATERAL CHARACTERISTIC

There are different arrangements possible requiring either a combination of two phase comparators or a four input comparator [12].

Type 1: Two restricted directional units are provided, one of them being offset from the origin by the replica impedance  $Z_R$  as shown in Fig. 10.12. Tripping area is the area between the two characteristics i.e. within the area OBAC on the impedance diagram. Hence  $Z_L$  must be between OB and OC and  $(Z_L - Z_R)$  must be between AB and AC. Such a comparator is not totally free from transient overreach for faults occurring at voltage zero, since  $Z_R$  is not the matched replica impedance of the line, although the problem may not be severe [18].

Type 2: A multi-input comparator is much better than a combination of two comparators as in type 1, as the outputs of the two may not occur at the same time. In one multi-input comparator having the below mentioned four inputs, the characteristic obtainable is shown in figure 4.3.

$$S_1 = Z_{R1} I_L \angle \theta_1 - \phi - K_1 \angle \alpha_1 V_L$$

$$S_2 = Z_{R2} I_L \angle \theta_2 - \phi$$

$$S_3 = Z_{R3} I_L \angle \theta_3 - \phi$$

$$S_4 = K_4 \angle \alpha_4 V$$

To enclose the fault area tightly,

$$Z_{R2} = X_R$$

$$Z_{R3} = R_R$$

$$Z_{R1} = R_R + jX_R = Z_R$$

The MHO circle created by the interaction of S1 and S2 is not going to mingle with the rectangular tripping area if  $Z_R = R_R + jX_R$  since the circle of diameter  $Z_R$  goes through the vertices of the rectangle bounded by  $R_R$  and  $X_R$ . Tripping occurs when all the conditions resulting from the comparison of all the inputs in pairs are simultaneously satisfied for a certain length of time as set by the delay unit.

Type 3: The undesired MHO circle in the previous case can be eliminated if at least one of the quantities  $I_L Z_R$  or  $(I_L Z_R - V_L)$  is pulsed. In case of a resistance fault appearing near the bus, a characteristic shown in fig (ram 285) is achieved giving a  $10^\circ$  shift in the characteristic. This is obtained by shifting  $I_L X_R$  and  $I_L R_R$  by  $10^\circ$ . For this,  $X_R$  is exchanged by impedance having a phase angle of  $80^\circ$ . In order to obtain a  $10^\circ$  shift in  $I_L R_R$ , a capacitor is placed in parallel with  $R_R$ . A quadrilateral characteristic can be obtained by using a multi-input phase comparator with the following inputs:

$$S_1 = I_L Z_R \text{ (pulse)}$$

$$S_2 = V_L \text{ (control input)}$$

$$S_3 = V_L \angle -90^\circ$$

$$S_4 = (I_L R_R - V_L)$$

Tripping occurs if the  $I_L R_R$  pulse occurs during the coincidence period of the three other sinusoidal inputs during a certain length of time as decided by the delay unit. This occurs only for an internal fault [39].

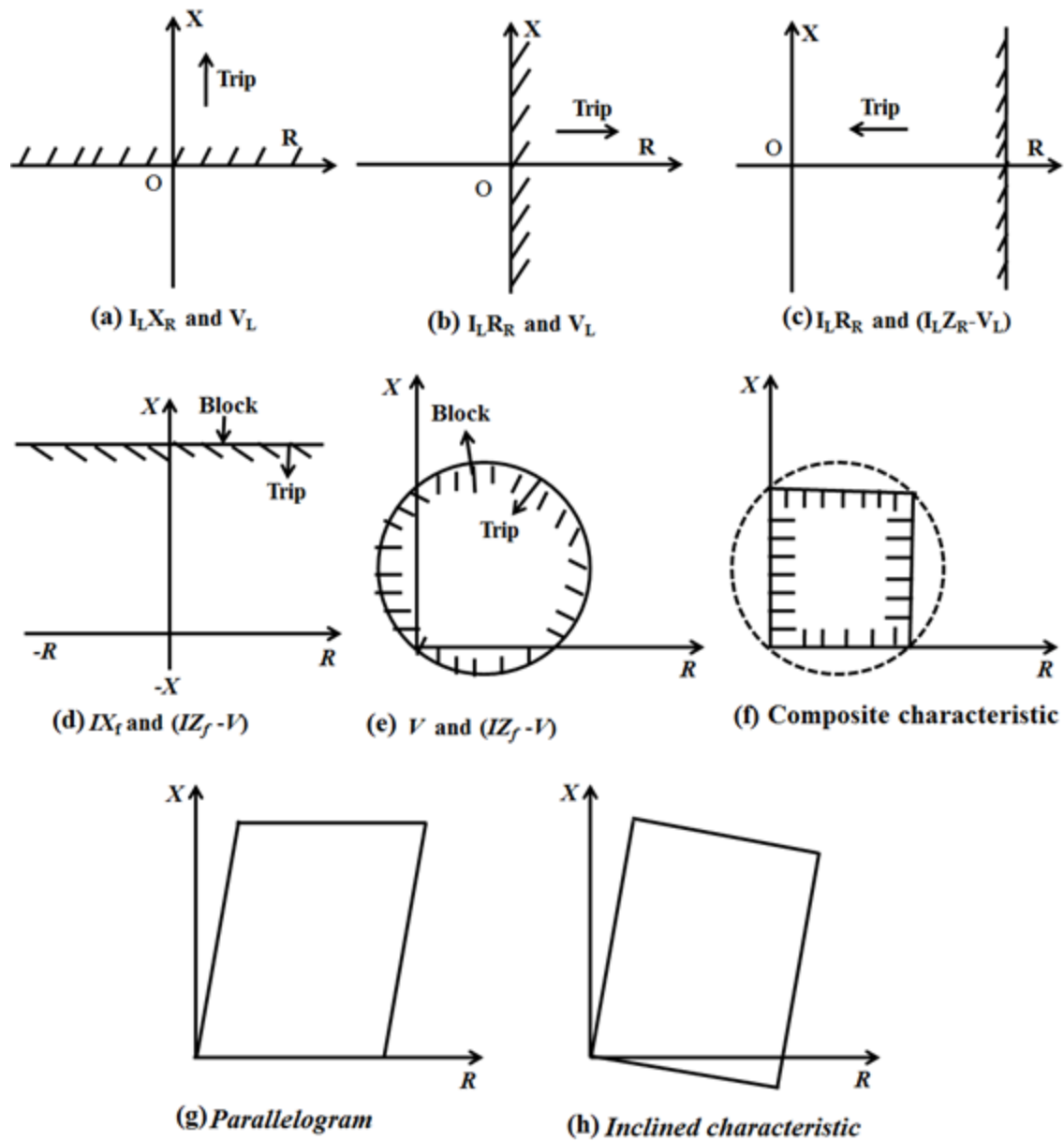

Figure 4.3: Various characteristics resulting from phase comparison of inputs indicated in figure 4.2.

#### 4.4 ADVANTAGES OVER OTHER DISTANCE RELAYS

As trapezoid or quadrilateral characteristics are quite popular with the numerical relays, previous generation of electromechanical and solid state relays used other characteristics like MHO characteristics, which were easier to derive. Mho relay circles usually enclosed a larger area than the quadrilateral characteristics for identical line impedance and arcing impedance parameters. Thus, they are more susceptible to unhealthy tripping. Hence, these characteristics have been overthrown by the trapezoidal characteristics [15], [37], [38].

##### 4.4.1 Arc resistance effect on the performance of distance relays

At higher voltages the arc resistance is reasonable. The increased resultant impedance which is seen by the distance relays is the combination of arc resistance and impedance of line. In case of ground faults earth resistance is also introduced. The arc resistance and earth resistance are collectively known as fault resistance. However in case of phase to phase faults, only arc resistance constitutes the fault resistance. The important reason for under-reach of distance relay is the presence of arc resistance [11], [18]. The empirical formula representing the arc resistance is called the Warrington formula proposed by V. C. Warrington [27]:

$$R_{arc} = \frac{29 \times 10^3 l}{I^{1.4}} \Omega$$

Where  $l$  = length of arc (meters) in still air and

$I$  = fault current (amp).

The arc resistance with respect to wind velocity and time is given by the following empirical formula:

$$R_{arc} = \frac{16300 (1.75 S + vt)}{I^{1.4}} \Omega$$

Where  $S$  = conductor spacing (meters),

$v$  = wind velocity (km /hr),

$t$  = time (s) and

$I$  = fault current (amp).

The arc resistance influences the performance of several types of distance relays to different extents. Figure 4.4 shows the characteristics of a MHO, reactance and impedance relays on the R-X diagram to protect the transmission line. If a fault occurs at the point F with arc resistance  $R_1$ , the MHO relay ceases to function but the impedance and reactance relay will function. However if the value of arc resistance is  $R_2$ , the MHO and impedance relays cease to function but the reactance relay will function. This demonstrates that the MHO relay is significantly affected, the impedance relay is adequately affected and the reactance relay is least affected by arc resistance [11], [33]. Since the reactance relay determines only reactance it is not at all affected by arc resistance.

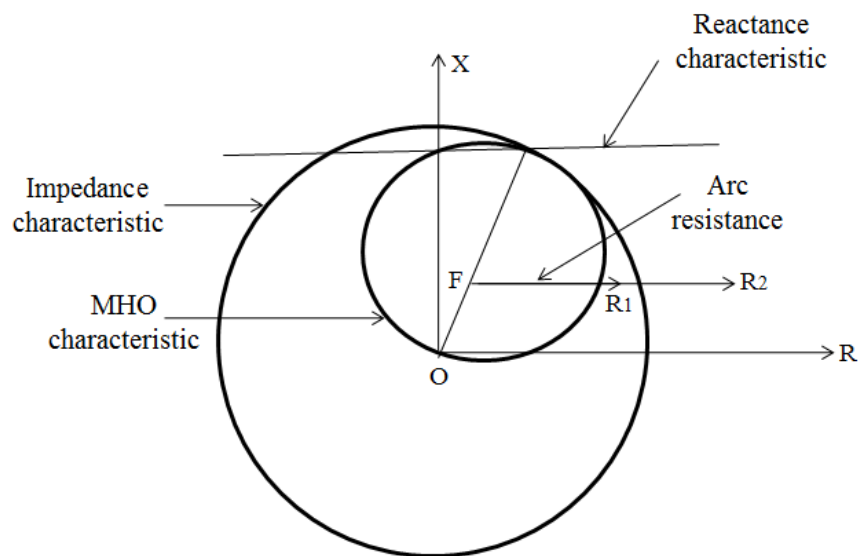

**Figure 4.4: Effect of arc resistance on distance relays.**

#### 4.4.2 Reach of the distance relays

A distance relay functions when the impedance or a component of the impedance as seen by the relay is less than a prespecified value. This prespecified impedance value or corresponding distance is known as the reach of the relay. In other words, it is the maximum

length of the line beyond which the operation of the relay should stop or we can say upto which the relay can protect. Distance relays have under-reaching and over-reaching tendencies depending upon the fault conditions [12], [18]. When a distance relay ceases to function even when the fault point is within its influence, but it is at the remote end of the

**Table 4.1: The extent of under reach of different relays due to arc resistance.**

<b>Relay</b>	<b>Under- reach due to arc resistance</b>
<b>Impedance</b>	<b>Moderate</b>
<b>Reactance</b>	<b>None</b>
<b>MHO relay</b>	<b>Maximum</b>
<b>Quadrilateral relay</b>	<b>None</b>

protected line, it is called under-reach. The basic reason for under-reach is the existence of fault resistance in the fault. The impedance seen by the relay is more than the actual impedance of the line upto the fault point due to the existence of fault resistance. Thus fault resistance causes under-reach of the distance relay. The fault resistance causes the underreach of the distance relays to different extents as shown in table 4.1.

The liability of the distance relay to function even when a fault point is beyond its preset reach i.e., protected length is known as the over-reach. One of the important reasons for such a tendency of the distance relays is the presence of DC offset in the fault current wave. This is called as transient over-reach. The impedance seen by the relay is less than the actual impedance of the line upto the fault point due to the presence of the DC offset in the fault current. The transient overreach phenomenon is defined as [18]:

$$\text{Percentage transient overreach} = \frac{Z_{OR} - Z_{SR}}{Z_{SR}} \times 100$$

Where,

$Z_{OR}$  = maximum impedance at which the relay will operate with an offset current wave for a given adjustment.

$Z_{SR}$  = maximum impedance at which the relay will operate for symmetrical current wave for the same adjustment.

With the increase in system angle  $\tan^{-1}\left(\frac{X}{R}\right)$  the transient overreach increases. This angle increases with the increase in the voltage of the line, the result being the larger spacing between conductors making the inductive reactance higher. This increases further with the bundling of conductors for the EHV/UHV lines.

Till now relay designers have not been able to minimize the overreach of the distance relay to less than 10% of its setting. In practical world, the percentage overreach is taken between 10% and 20%. Therefore, the distance relays cannot be set to 100% of the line length to provide high speed primary protection to the complete line [22]. The high speed distance relay of zone-I is adjusted to 80% to 90% of the entire line length. The margin of 10% to 20% is left for transient overreach, error in line impedance calculation and errors in CT's and PT's.

#### **4.4.3 Power swing effects on the performance of distance relays**

A power swing seen by the distance relay seems like a fault which is adjusting its distance from the location of the relay [4]. The characteristics of some important distance relays and power surge are shown on the R-X diagram, Figure 4.5. It is obvious from the figure that the

relay characteristic capturing larger area on the R-X diagram remains under the effect of the power surges. The MHO relay having the minimum area on the R-X diagram is least affected. The characteristics of an impedance relay are occupying larger area than MHO relay is adequately affected while the reactance relay occupying the largest area is significantly affected [9], [13], [22]. It is now clear that MHO relay is least affected by power swings and most affected by arc resistance while as reactance relay is least affected by arc resistance and most affected by power swings. Thus a combined effect of power swings and arc resistance on transmission lines restricts the MHO relay only for the protection of long transmission lines, as the impedance of long line is large, the arc resistance will not cause appreciable error and its effect can be neglected, and reactance relay only for the protection of short transmission lines, as in case of short lines, power surges remain for a shorter period and hence their effect is unimportant [23], [24]. But the quadrilateral characteristic is least affected by power surges, arc resistance and overloads [37] and hence are best suitable for the protection of both short and long transmission lines.

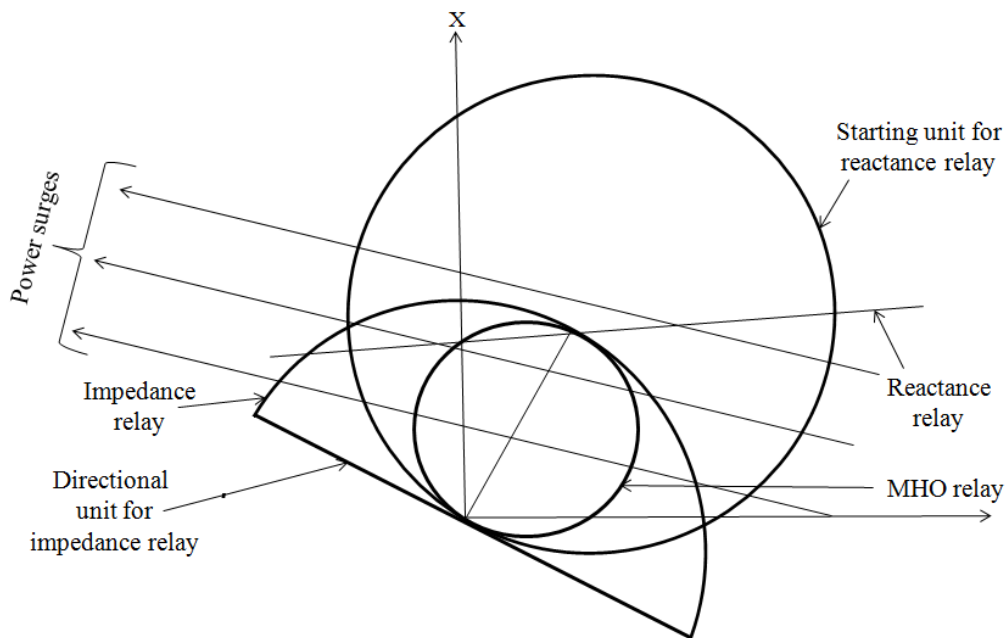

**Figure 4.5: Effect of power surges on distance relays.**

## 4.5 ARDUINO UNO R3 BOARD

The ARDUINO UNO board is an open source coding platform. It is the latest technology developed with simplest means of interfacing the data acquisition system. It includes the ATmega328 microcontroller. It has 14 digital input/output pins (of which 6 can be used as PWM outputs), 6 analog inputs, a 16 MHz crystal oscillator, a USB connection, a power jack, an ICSP header, and a reset button. In order to support the microcontroller the ARDUINO UNO contains everything which is to be needed for the proper operation of the microcontroller. In order to get started just connect the ARDUINO board to your computer using a USB cable. We can also use an AC to DC adapter or a battery to supply the required power for its proper operation. The main difference between the UNO and all other previous boards is that it excludes the use of FTDI USB to serial driver chip. For communicating with other devices such as microcontrollers, computers and other ARDUINO boards the ARDUINO UNO possesses a number of facilities. UART TTL (5V) serial communication is provided by the ATmega328, which is present on the digital pins 0 (RX) and 1 (TX). For exchanging the simple textual data between a device and a UNO board the ARDUINO software contains a serial monitor. When data is being transferred through the USB to serial chip and USB connection to the computer, the RX and TX LEDs on the board will definitely flash.

### 4.5.1 Technical features of ARDUINO UNO board

Microcontroller	ATmega328
Operating Voltage	5V
Input Voltage (recommended)	7-12V
Input Voltage (limits)	6-20V
Digital I/O Pins	14 (of which 6 provide PWM output)
Analog Input Pins	6
DC Current per I/O Pin	40 mA
DC Current for 3.3V Pin	50 mA
Flash Memory	32 KB of which 0.5 KB used by boot loader
SRAM	2 KB
EEPROM	1 KB

Clock Speed	16 MHz
-------------	--------

#### DESCRIPTION AND WORKING OF ATmega328 MICROCONTROLLER [32]

Manufacturer	Atmel
Pins	40
Programmable Pins	32
ADC Channel	8 channels, 10-bit
Speed Grade	Up to 16 MHz
Operating Voltage	4.5 V – 5.5 V
Power consumption at 1 MHz	1.1 mA
Instructions execution per cycle	131
Timer	Two 8bit / One 16 bit

#### 4.6 WORKING OF ATMEGA328 MICROCONTROLLER

ATmega328 Microcontroller has some good features as required for our project. It has 8 ADC inputs which can be used for our required 6 analog inputs [17]. There are two more ADC input left which can be used for further analog inputs. Inbuilt frequency of this microcontroller is 1 MHz and can be upgraded upto 16 MHz by using crystal oscillator. We can use 24 pins as output and 8 pins as ADC input. 8 pins are used for LCD display. One Pin is used for controlling the relays.

## CHAPTER 5

### IMPLEMENTATION OF QUADRILATERAL RELAY

An ARDUINO UNO board with ATmega328 microcontroller based quadrilateral distance relay has been designed, developed and tested in the laboratory conditions. The block schematic diagram of the proposed ARDUINO UNO based quadrilateral relay is shown in figure 5.1. The description of different blocks of the schematic diagram is given below:

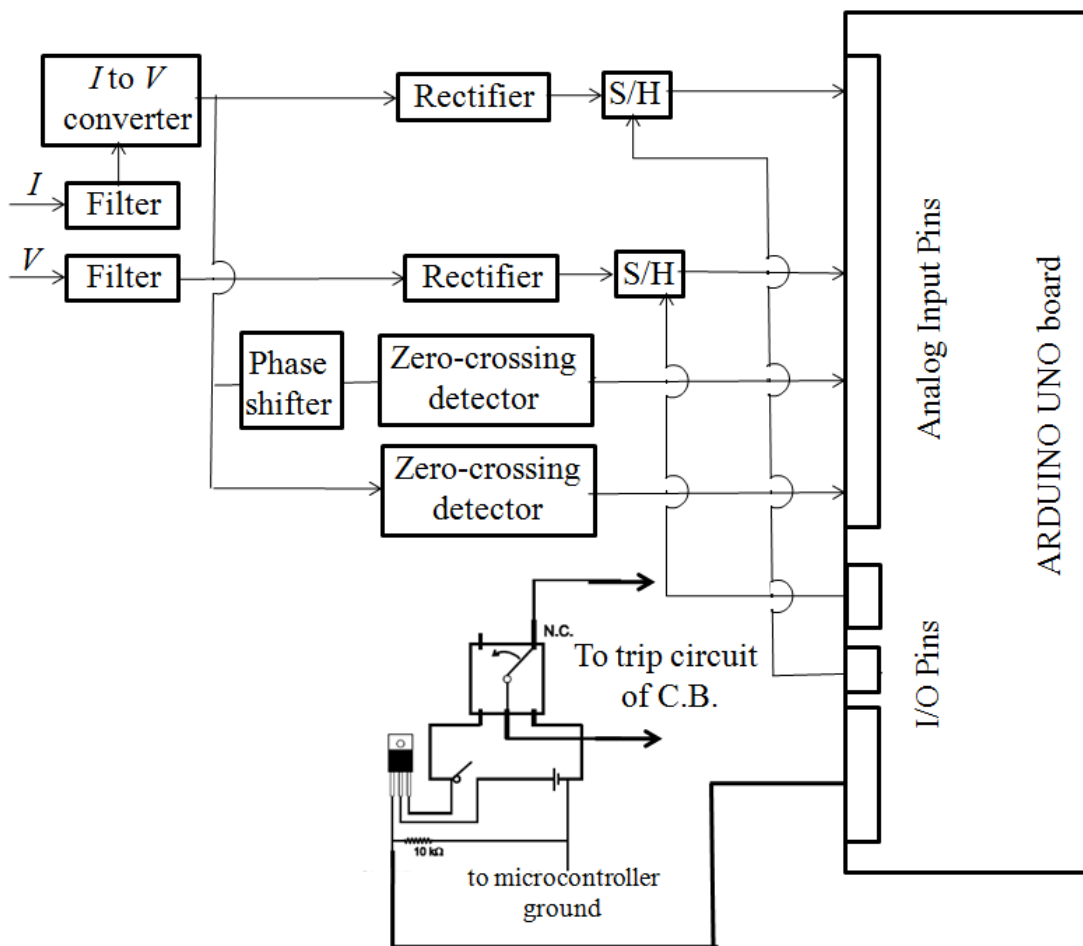

Figure 5.1: block schematic diagram of the proposed ARDUINO UNO based quadrilateral relay

## **5.1 CURRENT TRANSFORMER (CT)**

Current transformer is basically used to perform two main tasks. Firstly it steps down the heavy power system currents to low values that are suitable for the operation of the relays and other measuring instruments connected to their secondary windings. Secondly it isolates the relay and meter circuits from the high voltages of the power system. Protective relays require reasonably accurate reproduction of the normal and abnormal conditions in the power network for correct sensing and functioning. Hence the CTs should be able to provide current signals to the relays and meters which are useful outcome of the primary currents. The current signal is converted into proportional voltage signal by a suitable i-v converter. In the present case CT1248-A1-RC has been used with turns ratio of  $1:1500 \pm 1\%$ , D.C. resistance of 45 to 65 ohms and current range of 0.05 to 10 Arms.

## **5.2 VOLTAGE TRANSFORMERS (VT)**

Voltage transformer was previously named as potential transformer (PT). The main function of the voltage transformer is to step down the voltage signals to the electronic levels so as to physically isolate the relays and other instruments from the high voltages of the power system. The voltage ratings of the secondary windings of the VTs have been standardised so that a degree of equivalency among the relays and meters of different manufacturers can be achieved. The voltage transformer should be able to provide voltage signals to the relay and meters which are useful reproductions of the primary voltage. In the present case we are using a VT of 220 to 6 V with a current rating of 500 milliampere (mA).

## **5.3 LOW PASS FILTER (LPF)**

Filters are used for blocking or attenuating certain frequencies that are undesired and passing other frequencies which are useful to our experimental set up. In a sampled data system the sampling rate is an important constraint to be reflected. In order to avoid aliasing errors sampling frequency ( $f_s$ ) must be at-least twice the largest frequency ( $f_m$ ), as per theoretical considerations, present in the sampled information. In a sampled data system aliasing error is eliminated by means of a low pass. An active low pass filter design leads to smaller component sizes, hence is preferable. In our proposed scheme we are using a  $3\text{ K}\Omega$  resistor and  $1\ \mu\text{F}$  for the design of a low pass filter with a cut off frequency of 53 Hz.

## 5.4 RECTIFIER

The output from the low pass filter contains ripple. In order to overcome this problem a smoothing circuit is necessary in the output. The full wave bridge rectifiers have been used to rectify the incoming current and voltage signals. Thus the ripple content has been removed from the output which is further fed to the ADC of the microcontroller for digital conversion. 1N4007 diodes have been used for the construction of the bridge rectifiers. Description of 1N4007 is given below:

Peak reverse breakdown voltage	1000 V
RMS reverse breakdown voltage	700 V
Average rectified output current	1 A
Peak forward surge current	30 A
Peak reverse current	5 A
Operating range	upto 40V

## 5.5 PHASE SHIFTER AND ZERO CROSSING DETECTOR

### 5.5.1 Measurement of resistance

The resistance as seen by the relay from relay location to fault point is given by:

$$\begin{aligned} R &= Z \cos \phi = \frac{V \cos \phi}{I} \\ &= \frac{V_m \cos \phi}{\sqrt{2} A_1 I_{dc}} \quad (\text{As } I \propto I_{dc} = A_1 I_{dc} \text{ where } A_1 \text{ is a constant}) \\ &= A \frac{V_m \cos \phi}{I_{dc}} \end{aligned}$$

Where  $A_1$  is a constant and equals to  $\frac{1}{\sqrt{2} A_1}$ .

$V_m \cos \phi$  is the instantaneous value of the voltage at the moment of peak current. To obtain a pulse at the moment of peak current, a phase shifting circuit and a zero crossing detector have been used. A phase shift of  $90^\circ$  is achieved when a current signal is fed to the phase shifter.

The required pulse is then obtained by feeding the output of a phase shifter to the zero crossing detector. As soon as the current crosses its peak, the microcontroller sends a command to the multiplexer to obtain the instantaneous value of the voltage at the moment of peak current, which is equal to  $V_m \cos \phi$  and reads through the A/D converter to store the digital value in memory. After getting the values of  $V_m \cos \phi$  and  $I_{dc}$ , the microcontroller calculates the value of resistance.

### 5.5.2 Measurement of reactance

The reactance as seen by the relay from relay location to fault point is given by:

$$\begin{aligned}
 X &= Z \sin \phi = \frac{V \sin \phi}{I} \\
 &= \frac{V_m \sin \phi}{\sqrt{2} A_1 I_{dc}} \\
 &= \frac{A V_m \sin \phi}{I_{dc}}
 \end{aligned}$$

The instantaneous value of the voltage at the moment of zero current is  $V_m \sin \phi$ . The microcontroller reads the output of the zero crossing detector and examines whether the current has reached its zero instant. As soon as the current crosses its zero, the microcontroller reads the instantaneous value of the voltage through multiplexer and A/D converter. After receiving the values of  $V_m \sin \phi$  and  $I_{dc}$  the microcontroller calculates the reactance. For the design of phase shifter and zero crossing detector UA741 IC along with suitable capacitors, resistors and diodes have

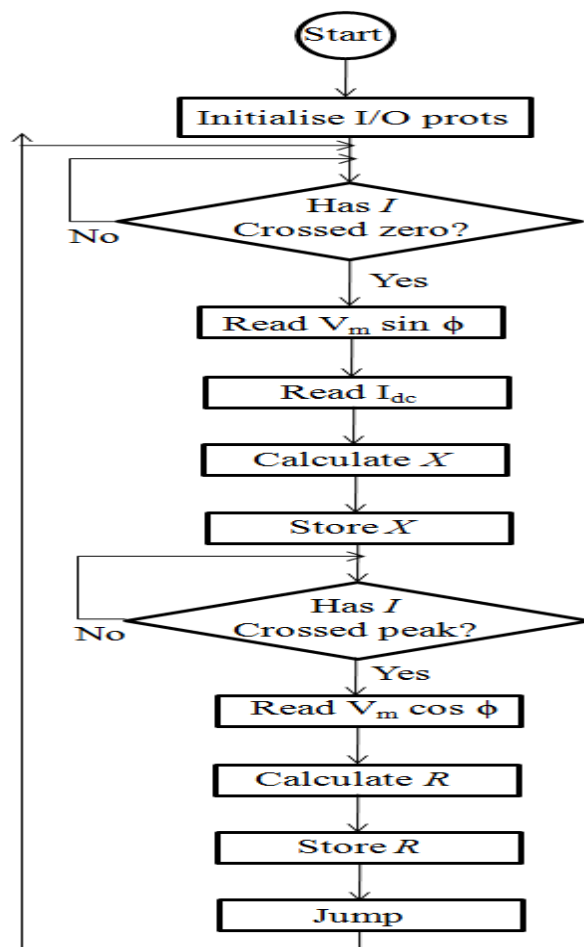

Figure 5.2. Program flow chart for measurement of R and X.

been employed. The program flow chart for the measurement of R and X and the circuit diagram of phase shifter and zero crossing detector are shown in figure 5.2 and figure 5.3 respectively.

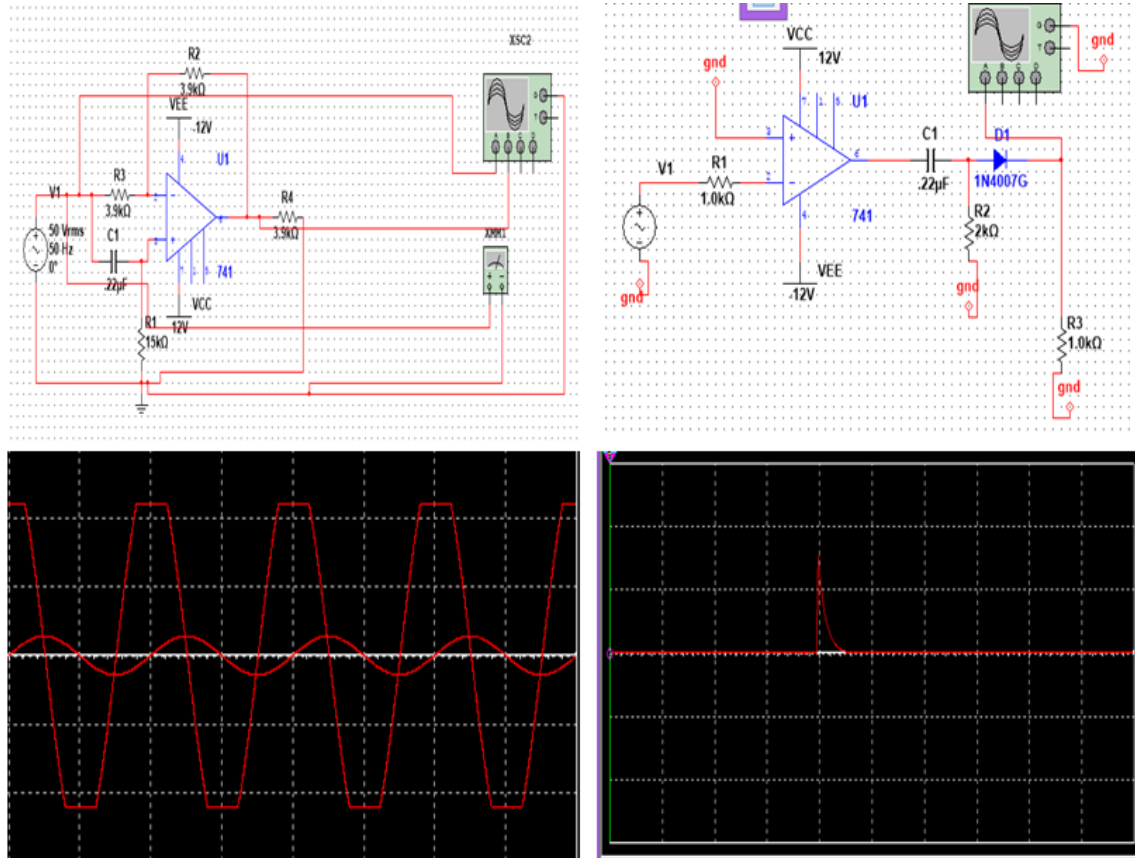

Figure 5.3: Circuit diagram and corresponding waveforms of phase shifter and zero crossing detector.

## 5.6 SAMPLE AND HOLD CIRCUIT (S/H)

An ADC takes a finite time, known as conversion time to convert an analog signal into digital form. If the input analog signal is not constant during the conversion period, the digital output of ADC will not correspond to the starting point of analog input. A S/H circuit is used to keep the instantaneous value of the rapidly varying analog signal constant during the conversion period. When the logic input is high it is in sample mode and the output follows the input with unity gain. When the logic input is low it is in the hold mode and the output of the S/H circuit retains the last value it had until the command switches for the sample mode. The S/H circuit is basically an opamp which charges a capacitor during the sample mode and retains

the value of the charge of the capacitor during the hold mode. LF398 IC and  $1\ \mu F$  has been used for the design of S/H circuit. The LF398 is a monolithic sample and hold circuit which utilises BI-FET technology to obtain high accuracy with fast acquisition of signal and low droop rate. A low droop rate of about  $5\text{mV}/\text{min}$  is obtained with a hold capacitor of  $1\ \mu F$  which is to be connected externally.

## **5.7 ARDUINO UNO BOARD**

The ARDUINO UNO board is an open source coding platform. In order to support the microcontroller the ARDUINO UNO contains everything which is to be needed for the proper operation of the microcontroller. It contains ATmega328 microcontroller for interfacing with the data acquisition system (DAS). ATmega328 realises processing rate approaching 1 MIPS per MHz by performing powerful commands in a single clock cycle thus permitting the system designer to enhance power consumption versus processing speed. Based on the AVR enhanced architecture the ATmega328/328P is a low-power CMOS 8-bit microcontroller.

A slave relay is connected in series with the trip circuit of the CB whose contacts are normally closed. On occurrence of a fault in any one of the three protective zones of the numerical distance relay i.e. when the measured values of R and X go beyond the prespecified value, a trip signal is sent by the microcontroller to the slave relay. Under normal program control the microcontroller creates the control for S/H circuit, the analog multiplexer and ADC. A digital value of the voltages and currents as converted by the ADC of the microcontroller has been displayed by using a  $16*2$  LCD display. When voltage and current goes beyond the limit, CB disconnects the transmission line from power supply on account of a trip signal sent by the microcontroller through the relay which actuates the trip circuit of the circuit breaker. LCD preset the supply voltage and displays a zero current at this particular moment.

## **5.8 FUNCTIONING OF THE PROPOSED RELAY**

In the proposed protection scheme the relay implemented is capable to pass 7A current at 300V AC and 10A current at 28V DC. A minimum voltage of 6V is required to operate the relay. The relay is operated by connecting a 9V battery across its terminals through a MOSFET between them. As soon as the 5V signal from the microcontroller is received by the MOSFET it will connect the relay with the battery and hence the relay will activate. Here the



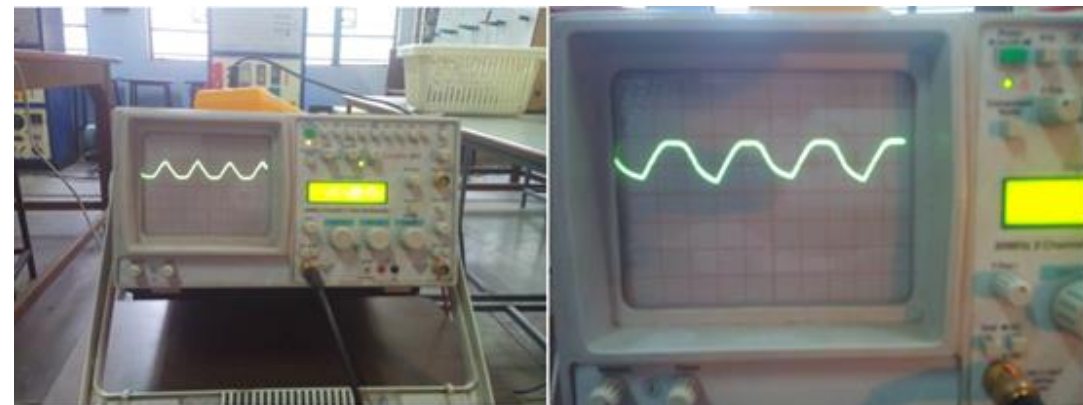
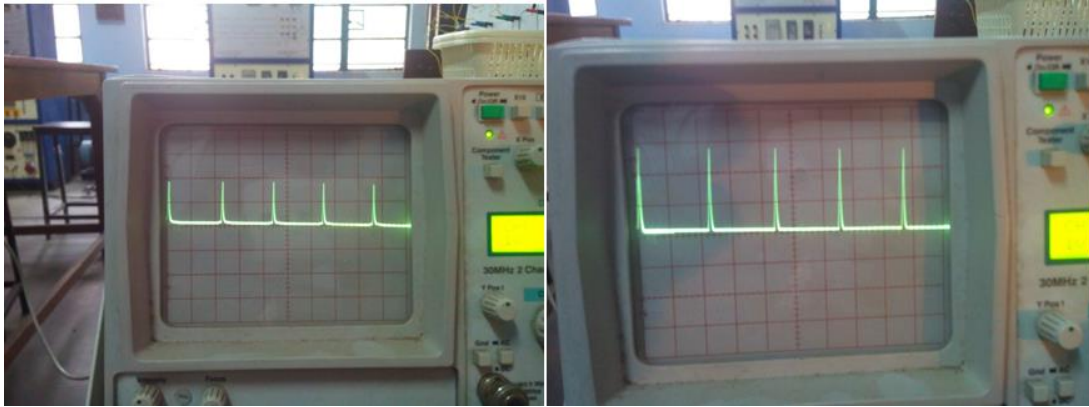

**Figure 5.6: waveforms of the bridge rectifier and S/H circuit.**

## **5.10 CIRCUIT SIMULATION MODEL**

MULTISIM simulation software has been used to conduct the entire relay circuitry. Figure 5.5 illustrates the whole pathway of design circuitry of the data acquisition system. MULTISIM is an electronic schematic capture and simulation program which is a part of a suit of circuit designed program.

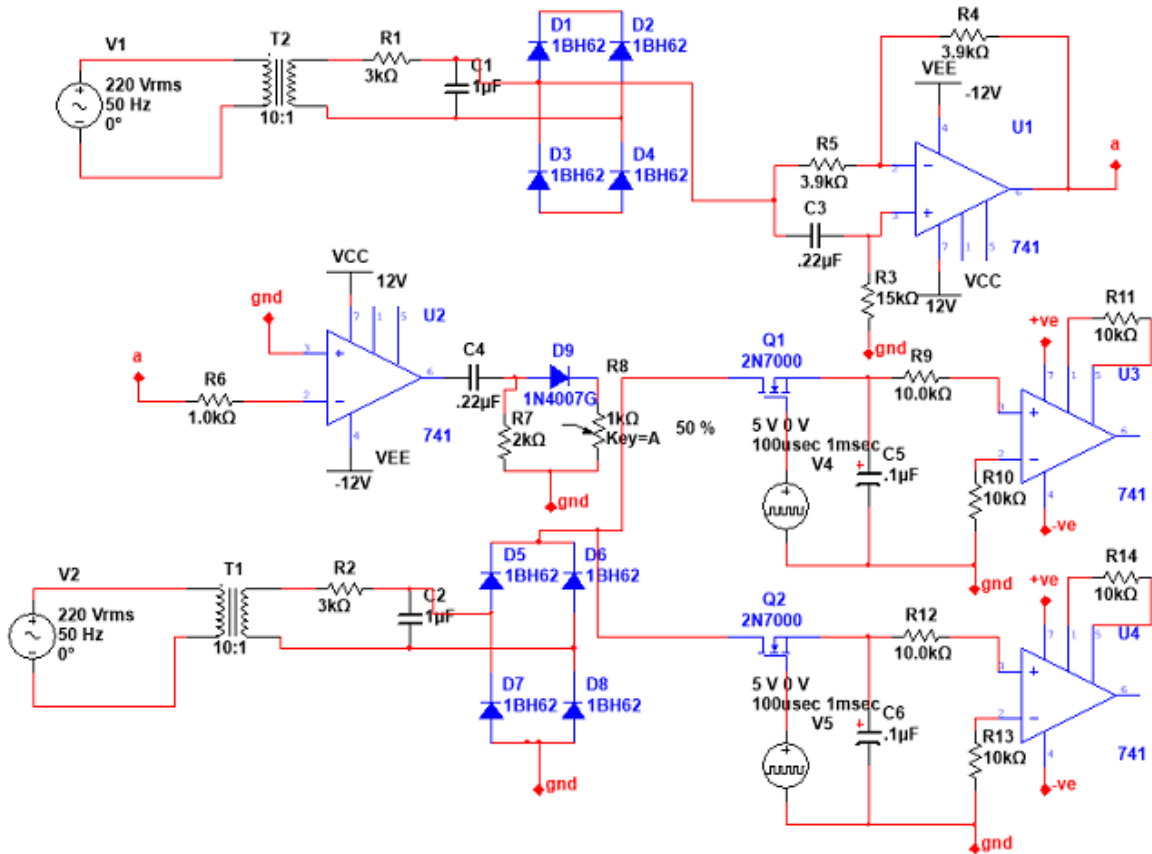

Figure 5.7: Simulation model of DAS.

## **CHAPTER 6**

### **CONCLUSIONS AND FUTURE SCOPE**

#### **6.1 CONCLUSIONS**

The dissertation theme is based on the protection of transmission line equivalent model under single line to ground (L-G) fault using microcontroller (ATmega328) based quadrilateral relay. The numerical relaying protection scheme has been designed and implemented under laboratory conditions using ARDUINO UNO board which is an open source coding platform. The ARDUINO contains ATmega328 microcontroller. The transmission line equivalent model under consideration is a single phase series R-L model which has been achieved by using four modules of inductance (80 mH/50km) and resistance ( $2\Omega/50\text{km}$ ) connected in series. The capacitance has been neglected for the test purpose. The equivalent model represents 200kms of a transmission line which has been divided into three zones of protection respectively. The quadrilateral characteristics have been determined through software. These possess the property of getting least affected by power swings, arc resistance and overloads as compared to the conventional distance relays. The microcontroller compares the measured and set values of the impedance and based on that decides whether to send a trip signal to the relay or not. The proposed scheme has been implemented on hardware and also the DAS has been simulated through MULTISIM software. The proposed scheme is fast, reliable and accurate.

#### **6.2 FUTURE SCOPE**

Since the proposed scheme has been implemented for single line to ground (L-G) fault conditions, however, it can be extended to three phase fault conditions by simply modifying the DAS as required. However the ARDUINO board will work efficiently for the three phase faults as well.

## REFERENCES:

- [1] G.D. Rockefeller, "Fault Protection with a Digital Computer," IEEE Transactions on Power Apparatus and Systems, Vol. PAS-88, No. 4, pp. 438-464, Apr. 1969.
- [2] M. Vitins, "A Fundamental Concept for High Speed Relaying," IEEE Transactions on Power Apparatus and Systems Vol. PAS-100, No. 1, pp. 163-173, Jan. 1981.
- [3] Z. Zhizhe and C. Deshu, "An Adaptive Approach in Digital Distance Protection," IEEE Transactions on Power Delivery, Vol. 6, No. 1, pp. 135-142, Jan. 1991.
- [4] A. Mechraoui and D. W. P. Thomas, "A New Blocking Principle with Phase and Earth Fault Detection during Fast Power Swings for Distance Protection," IEEE Transactions on Power Delivery, Vol. 10, No. 3, pp. 1242-1248, Jul. 1995.
- [5] F. H. Magnago and A. Abur, "Fault Location using Wavelets," IEEE Transactions on Power Delivery, Vol. 13, No. 4, pp. 1475-1480, Oct. 1998.
- [6] M. M. Eissa and M. Masoud, "A Novel Digital Distance Relaying Technique for Transmission Line Protection," IEEE Transactions on Power Delivery, Vol. 16, No. 3, pp. 380-384, Jul. 2001.
- [7] Q. H. Wu, J. F. Zhang, and D. J. Zhang, "Ultra-High-Speed Directional Protection of Transmission Lines Using Mathematical Morphology," IEEE Transactions on Power Delivery, Vol. 18, No. 4, pp. 1127-1133, Oct. 2003.
- [8] X. Dong, Y. Ge and J. He, "Surge Impedance Relay," IEEE Transactions on Power Delivery, Vol. 20, No. 2, pp. 1247-1256, Apr. 2005.
- [9] L. Zou, Q. Zhao, X. Lin and P. Liu, "Improved Phase Selector for Unbalanced Faults during Power Swings using Morphological Technique," IEEE Transactions on Power Delivery, Vol. 21, No. 4, pp. 1847-1855, Oct. 2006.

- [10] H. A. Darwish and M. Fikri, "Practical Considerations for Recursive DFT Implementation in Numerical Relays," *IEEE Transactions on Power Delivery*, Vol. 22, No. 1, pp. 42-49, Jan. 2007.
- [11] S. H. Horowitz and A. G. Phadke, "Power System Relaying," John Wiley & Sons, May 2009.
- [12] J. L. Blackburn and T. J. Domin, "Protective Relaying: Principles and Applications," CRC press, 2006.
- [13] X. Lin, Y. Gao and P. Liu, "A Novel Scheme to Identify Symmetrical Faults Occurring During Power Swings," *IEEE Transactions on Power Delivery*, Vol. 23, No. 1, pp. 73-78, Jan. 2008.
- [14] Z. Y. Xu, S. F. Huang, L. Ran, J. F. Liu, Y. L. Qin, Q. X. Yang, and J. L. He, "A Distance Protection Relay for a 1000-kV UHV Transmission Line," *IEEE Transactions on Power Delivery*, Vol. 23, No. 4, pp. 1795-1804, Oct. 2008.
- [15] M. Harikrishna, "Performance of Quadrilateral Relay on EHV Transmission Line Protection during Various Faults," *ACEEE International journal on Control System and Instrumentation*, Vol. 1, No. 1, pp. 1-6, Jul. 2010.
- [16] K. Saravanababu, P. Balakrishnan and K. Sathiyasekar, "Transmission Line Faults Detection, Classification and Location using Discrete Wavelet Transform," 2013 IEEE International Conference on Power, Energy and Control (ICPEC), Dindigul, India, Feb. 2013, pp. 233-238.
- [17] M. A. Haj-ahmed and M. S. Illindala, "Intelligent Coordinated Adaptive Distance Relaying," *Electric Power Systems Research*, Vol. 110, pp. 163-171, Jan. 2014.
- [18] B. A. Oza, N. C. Nair, R. P. Mehta and V. H. Makwana, "Power System Protection and Switchgear," Tata McGraw Hill, New Delhi, India, 2010.
- [19] K. Ravishankar and D. Thukaram, "Analysis of Distance Relay Trip Regions for EHV and UHV transmission lines," 2011 IEEE International Conference on Power and Energy Systems (ICPS), Chennai, India, Dec. 2011 pp. 1-6.

- [20] M.S. Sachdev and M.A. Baribeau, "A New Algorithm for Digital Impedance Relays," IEEE Transactions on Power Apparatus and Systems, Vol. PAS-98, No.6, pp. 2232-2240, Nov. /Dec. 1979.
- [21] J. K. Wu, B. T. He, Y. Hu, D. S. Luo, and Y. Liang, "A Novel Method for Removal of DC Component in Non-sinusoidal Signal of Power Systems," 2004 IEEE PES Power Systems Conference & Exposition, Oct. 2004, Vol. 2, pp. 1190-1197.
- [22] S. Li, M. Ding, N. Yorino and Y. Zoka, "Operation Condition for Zone 3 Impedance Relays during Low-Frequency Power Swings," The third IEEE international conference on deregulation and restructuring and power technologies (DRPT), Nanjing, China, Apr. 2008, pp. 2316-2321.
- [23] C. Pang, and M. Kezunovic, "Fast Distance Relay Scheme for Detecting Symmetrical Fault During Power Swing," IEEE Transactions on Power Delivery, Vol. 25, No.4, pp. 2205-2212, Oct. 2010.
- [24] S. Warathe and R. N. Patel, "Algorithm for Power Swing Protection using DSP based Numerical Relay," 2<sup>nd</sup> IEEE International Conference on Signal Processing and Integrated Networks (SPIN), Noida, India, Feb. 2015, pp. 762-767.
- [25] F. Engler, O. E. Lanz, M. Hanggli and G. Bacchini, "Transient Signals and their Processing in an Ultra High Speed Directional Relay for EHV/UHV Transmission Line Protection," IEEE Transactions on Power Apparatus and Systems, Vol. PAS-104, No.6, pp. 1463-1473, June 1985.
- [26] S. M. Hashemi, M. T. Hagh, and H. Seyedi, "Transmission-Line Protection: A Directional Comparison Scheme Using the Average of Superimposed Components," IEEE Transactions on Power Delivery, Vol. 28, No. 2, pp. 955-964, Apr. 2013.
- [27] V.C. Warrington, "Protective Relays: Their Theory and Practice," Vol. 2, pp. 304- 316, Chapman & Hall, 1972.
- [28] Y. Q. Xia, J. L. He and K. K. Li, "A Reliable Digital Directional Relay based on Compensated Voltage Comparison for E.H.V Transmission Lines," IEEE Transactions on Power Delivery, Vol. 7, No. 4, pp. 1955-1962, Oct. 1992.

- [29] K. Parthasarathy, "Static and Semi-static Conic Distance Relays," *Electrical Times*, pp. 119-125, Jul. 1965.
- [30] A. Shanmugasundaram, S. Palanichamj, G. Gangadharan and P. Bhoopathirajan, "Development of a Static Distance Relay with Conic Characteristics for the Protection of Long Transmission Lines," *I.E.E.-I.E.R.E. Proceedings-India*, Vol. 14, No. 5, pp. 192-199, Sep.-Oct. 1976.
- [31] M. Sreeram and P. Raja, "Implementation of DSP Based Numerical Three-Step Distance Protection Scheme for Transmission Lines," 2013 Annual IEEE India Conference (INDICON), Mumbai, India, Dec. 2013, pp. 1-6.
- [32] <http://www.atmel.in/Images/doc2503.pdf>.
- [33] Y. Hu, D. Novosel and M. M. Saha, "An Adaptive Scheme for Parallel Line Distance Protection," *IEEE Transactions on Power Delivery*, Vol.17, pp. 105-110, pp. 105-110, Jan. 2002.
- [34] S. Sengupta and A. K. Mukhopadhyay, "A Microprocessor-Based High-Speed Relay for Protection of Parallel EHV/UHV Feeders Using Waveform Comparison Technique," *Electric Power Components and Systems*, Vol. 31, No.9, pp. 891-897, Sep. 2003.
- [35] D. Fischer and R. Beresh, "Design of a Low Cost Digital Protection Relay used as a Teaching Platform," 24th Canadian Conference on Electrical and Computer Engineering (CCECE), Niagara Falls, Canada, May 2011, pp. 112-116.
- [36] A. Gartia, A. Gartia, A. Gulati and C. Kumar, "Microcontroller Based Line Differential Protection Using Fibre Optic Communication," *Innovative Smart Grid Technologies-Asia (ISGT Asia)*, Bangalore, India, Nov. 2013, pp. 1-4.
- [37] K. Shrivastava and D. N. Vishwakarma, "Microcontroller-based Numerical Quadrilateral Relay for the Transmission Line Protection," *Electric Power Components and Systems*, Vol. 35, No. 12, pp. 1301-1315, Sep. 2007.
- [38] J. Han and P. A. Crossley, "Fault Location on a Mixed Overhead and Underground Transmission Feeder Using a Multiple-Zone Quadrilateral Impedance Relay and a Double-ended Travelling Wave Fault Locator," 12th IET International Conference on Developments in Power System Protection (DPSP), Copenhagen, Denmark, Mar. /Apr. 2014, pp. 12-52.

- [39] "IEEE Draft Guide for Protective Relay Applications to Transmission Lines," IEEE PC37.113/D7.0, Aug. 2014.
- [40] G. R. Slemon, S. D. T. Robertson and M. Ramamoorthy, "High Speed Protection of Power Systems Based on Improved System Models," CIGRE, Paris, 1969, Paper No. 31-09.
- [41] M. Ramamoorthy, "A Note on Impedance Measurement Using Digital Computers," IEE-IERE Proceedings (India), Vol. 9, No. 6, pp. 2143-2147, Nov. /Dec. 1971.
- [42] B. J. Mann and I. F. Morrison, "Digital Calculation of Impedance for Transmission Line Protection," IEEE Transactions on Power Apparatus and Systems, Vol. PAS-90, No. 1, pp. 270-279. Jan. /Feb. 1971.
- [43] B. J. Mann and I. F. Morrison, "Relaying a Three-Phase Transmission Line with a Digital Computer," IEEE Transactions on Power Apparatus and Systems, Vol. PAS- 90, No. 2, pp. 742-750, Mar. /Apr. 1971.
- [44] T. E. Dyliacono, "The Adaptive Reliability Control System", IEEE Transactions on Power Apparatus and Systems, Vol. PAS-86, No. 5, pp. 517-531, May 1967.
- [45] G. G. Richardson and O. T. Tan, "An Accurate Fault Location Estimator for Transmission Lines", IEEE Transaction on Power Apparatus and Systems, Vol.PAS-101, No. 4, pp. 945-950, Apr. 1982.
- [46] M. E. Erezzaghi and P. A. Crossley, "The Effect of High Resistance Faults on a Distance Relay", IEEE Power Engineering Society General Meeting, Vol. 4, pp. 2128-2133, Jul. 2003.