

**RELIABILITY ANALYSIS OF AN INDUSTRIAL SYSTEM  
USING T-NORM AND T-CONORM OPERATIONS**

*A Thesis*

*Submitted in partial fulfillment of the  
requirement for the award of the degree*

*of*

**Master of Science**

*in*

**Mathematics and Computing**

*by*

**SHAWETA GARG**

**Roll No. 301403017**

*Under the guidance of*

**Dr. Harish Garg**



School of Mathematics  
Thapar University  
Patiala – 147004 (Punjab)

INDIA

July 2016

## CANDIDATE'S DECLARATION

I hereby certify that the work which is being presented in the thesis entitled "**Reliability Analysis of an Industrial Systems using T-Norm And T-Conorm Operations**" in partial fulfillment of the requirement for the award of degree of Master of Science, School of Mathematics (SOM), Thapar University, Patiala is an authentic record of my own carried out under the supervision of Dr. Harish Garg, Assistant Professor, SoM, Thapar University Patiala.

The matter presented in this thesis has not been submitted by me for the award of any other degree of this or any other institute.

*Shaweta Garg*

**(SHAWETA GARG)**

**Reg. No. 301403017**

This is to certify that the above statement made by the candidate is correct and true to the best of my knowledge.

Date: July 15, 2016

*Harish*  
**(Dr. Harish Garg)**

Supervisor

Countersigned by:

*A.K. Lal*

**Dr. A.K. Lal**

Head SOM

Thapar University

Patiala

*S.S. Bhatia*

**Prof. S. S. Bhatia**

Dean of Academic Affairs

Thapar University

Patiala

# Abstract

In the present era of global competition and faster delivery times, it has become imperative for all production systems to perform satisfactorily during their expected life span. However, failure is an inevitable fact related with technological products and systems used in all industries. Any unfortunate consequences of unreliable behavior of such equipments or systems leads to the desire for reliability analysis. Therefore, in recent years, the importance of reliability theory has been increasing greatly with the innovation of recent technology for the purpose of making good products with high quality and designing highly reliable systems. Now a days, researchers are paying more attention to the real life problem of improving the performance as well as profit margin of an industrial system. Therefore, in recent years, system reliability becomes an important issue in evaluating the performance of an engineering system and when it is low, efforts are desired for each subsystem/unit of a system by reducing their likelihood failures. For this detailed knowledge of failure behavior of the system as well as its components are needed so that suitable maintenance strategies may be applied for improving its performance. Thus, in the present scenario of global competition and faster delivery times, it is an important topic for decision-makers to fully consider the actual business and the quality requirements together. This is the reason why there is a growing interest in implementation and investigation of reliability principles for industrial systems.

The present thesis is organized into four chapters which are briefly summarized as follows:

A brief account of the related work of various authors in the evaluation of reliability of an industrial system by using conventional, fuzzy and optimization techniques is presented in the first chapter. In **Chapter 2**, the basic and preliminaries related to the reliability

theory, fuzzy set theory and intuitionistic fuzzy set theory and to be used in the subsequent chapters are given.

**Chapter 3** presents a concept of generalized t-norm operation based methodology for analyzing the behavior of the industrial systems. For this, data related to various component of the system are extracted from the various resources and hence fuzzy set theory has been used for handling the uncertainties in the data. After quantifying the uncertainties, generalized fuzzy union and intersection operations have been used for depicting the membership functions of various reliability parameters such as failure rate, repair time, MTBF, reliability, availability etc. Both Sensitivity analysis and performance analysis have been conducted for finding the most critical component of the system in order to increase the efficiency of the system. A washing unit of the paper mill, a complex repairable industrial system, has been taken to validate the approach algorithm.

In **Chapter 4**, an approach has been presented which deal with the intuitionistic fuzzy set (IFS) theory to analyze the reliability of series, series-parallel and mixed configuration structure. In this approach, uncertainties in the data are handled with the help of IFS and by integrating the experts knowledge and experience in terms of possibilities of failure of bottom events, a flexible and more realistic approach to analyze the fuzzy reliability of complex systems under uncertain environment has been presented.

# Acknowledgment

First of all, I would like to thank the almighty for granting perseverance. Every project is successful largely due to the effort of wonderful people who have always given their valuable advice or lent a helping hand. I would like to express my gratitude to my honorable supervisor Dr. Harish Garg, Assistant Professor, School of Mathematics (SOM), Thapar University, Patiala, for his guidance, motivation, immense knowledge and engagement through the learning process of this master thesis. I am thankful to him for introducing me to the topic as well as for the support on the way. The door to his office was always open whenever I ran into a trouble spot or had a question about my research or writing. Without his passionate participation and input, the validation survey could not have been successfully conducted. I am grateful to my mentor for enlightening me the first glance of research.

Besides my supervisor, I am thankful to Dr. A.K. Lal, Head, SOM, Thapar University, Patiala, for providing all the necessary facilities in the school.

I owe my gratitude to my family, who have supported me spiritually throughout entire process, both by keeping me harmonious and helping me putting pieces together. Without their support and endless blessings, it is impossible for me to complete my education seamlessly. I will be grateful forever for your love.

Last but not the least, I am heartfelt to my friends for the stimulating discussions, for the times we work together before deadlines, and for all the moments we have fun together. I greatly value their friendship and deeply appreciate their belief in me.

*Shaweta Garg*  
(Shaweta Garg)

Patiala

July 15, 2016

# Table of Contents

<b>Abstract</b>	<b>i</b>
<b>Acknowledgment</b>	<b>iii</b>
<b>Table of Contents</b>	<b>iv</b>
<b>List of Tables</b>	<b>vi</b>
<b>List of Figures</b>	<b>vii</b>
<b>1 Introduction</b>	<b>1</b>
1.1 Review of Literature . . . . .	1
1.2 Objectives of the Thesis . . . . .	2
1.3 Structure of the Thesis . . . . .	3
<b>2 Preliminaries</b>	<b>4</b>
2.1 Reliability Aspects . . . . .	4
2.1.1 Reliability . . . . .	4
2.1.2 Availability . . . . .	5
2.2 Basic concepts on fuzzy set theory . . . . .	6
2.2.1 Classical Sets (Crisp Sets) . . . . .	6
2.2.2 Fuzzy set theory . . . . .	6
2.2.3 $\alpha$ - cuts . . . . .	7
2.2.4 Convex fuzzy set . . . . .	7
2.2.5 Normal fuzzy set . . . . .	8
2.2.6 Fuzzy number . . . . .	8
2.3 Intuitionistic fuzzy set theory . . . . .	8
2.3.1 $\alpha$ - level set or cut of an IFS . . . . .	9

2.3.2	Convex intuitionistic fuzzy set . . . . .	9
2.3.3	Normal IFS . . . . .	10
2.3.4	Intuitionistic fuzzy number (IFN) . . . . .	10
2.4	t-Norms & t-Conorms . . . . .	11
2.4.1	Fuzzy Intersection: t-Norms . . . . .	11
2.4.2	Fuzzy Unions: t-Conorms . . . . .	12
<b>3</b>	<b>Reliability analysis of an industrial system using t-norm operations</b>	<b>14</b>
3.1	Introduction . . . . .	14
3.2	Methodology . . . . .	15
3.3	Case study . . . . .	16
3.3.1	System description . . . . .	16
3.3.2	Behavior analysis . . . . .	17
3.3.3	Performance analysis . . . . .	22
3.4	Conclusion . . . . .	23
<b>4</b>	<b>Fuzzy system reliability analysis by the use of norm operations on intuitionistic fuzzy number</b>	<b>25</b>
4.1	Overview . . . . .	25
4.2	Compensatory Operator . . . . .	26
4.2.1	‘AND’ operator . . . . .	26
4.2.2	‘OR’ operator . . . . .	26
4.3	Illustrative Example . . . . .	27
4.3.1	Series System . . . . .	27
4.3.2	Series-parallel system . . . . .	28
4.3.3	Sump pump system . . . . .	32
4.4	Conclusion . . . . .	35
	<b>Bibliography</b>	<b>36</b>

# List of Tables

3.1	Some Reliability Parameters . . . . .	16
3.2	Input data for the main components of the Washing system . . . . .	18
3.3	Generalized Triangular fuzzified data for the main components system . . . . .	18
3.4	Membership values for various reliability parameters values . . . . .	19
3.5	Crisp and defuzzified values of the system . . . . .	21
3.6	Variation of Failure rates and Repair times on the System Availability of Washing System . . . . .	22
4.1	Input data for series system . . . . .	28
4.2	Series system reliability values at different $\alpha$ and $\beta$ -cuts for $\gamma = 0$ . . . . .	29
4.3	Series system reliability values at different $\gamma$ . . . . .	30
4.4	Input data for series-parallel system . . . . .	31
4.5	Series-parallel system reliability values at different $\gamma$ . . . . .	32
4.6	Input data for the main component of the pump . . . . .	34
4.7	Reliability of basement flooding system at different values of parameter $\gamma$ . . . . .	35

# List of Figures

2.1	A fuzzy set $\tilde{A}$ . . . . .	7
2.2	Representation of a IFS set . . . . .	9
3.1	Systematic diagram of Washing system . . . . .	17
3.2	Fuzzy Reliability Indices Plots for Washing system . . . . .	20
3.3	Effect of varying Failure rate and Repair time on Washing System Availability	23
4.1	Structure of the series system . . . . .	27
4.2	Series-parallel system . . . . .	28
4.3	Series-Parallel system Reliability at different values of parameter $\gamma$ . . . . .	31
4.4	Systematic diagram and Fault tree model of a sump pump system . . . . .	33
4.5	Reliability of sump-pump system at different values of parameter $\gamma$ . . . . .	34

# Chapter 1

## Introduction

The objective of this work is to predict/analyze the behavior and performance analysis of an industrial systems more closely by utilizing uncertain, vague and imprecise data. A brief literature review regarding reliability/availability evaluation under the fuzzy and intuitionistic fuzzy set environment are given hereafter.

### 1.1 Review of Literature

Reliability is a popular concept that has been celebrated for years as an admirable characteristic of a person. Today reliability has grown into a universal attribute with qualitative and quantitative connotations that pervades every aspect of our present day technologically intensive world. Under the complex repairable industrial systems, reliability analysis is one of the most important task for performing and analyzing the uncertain behavior of system using various techniques which requires the knowledge of precise numerical probabilities and component functional dependencies, the information which is rather difficult to obtain. Even if data is available, it is often inaccurate and thus, subjected to uncertainty, because historical data are mostly represent the past actions but may be incapable of predicting the upcoming behavior of the system. Further age, adverse operating conditions and the vagaries of manufacturing/ production processes affects each part of system differently. Thus, for handling it, researchers have worked on the fuzzy set theory [24] and its arithmetic for dealing the uncertainties in the data in a more precise way. The reliability measures in terms of fuzzy set theory and fuzzy arithmetic can be found in the literature [3–5, 19, 22, 23] etc.

After the successful application of fuzzy set theory in various disciplines, various researchers are engaged in their extension. Among these extension the one that have drawn the attentions of many researchers during the last decade is the theory of intuitionistic fuzzy set (IFS) introduced by Attanassov in 1986 [1]. The concept of IFS may be viewed as an alternative of the fuzzy set in the case where available information is not sufficient for defining the membership function by means of the conventional fuzzy set. In IFS, an extra degree of membership called degree of rejection or non-membership has been added in order to model the hesitation and uncertainty about the membership degree of belonging. In other words, in IFS there is consideration of two degrees of membership called acceptance and rejection, respectively such that the sum of both values is less than or equal to one. On the other hand, in fuzzy set theory only degree of acceptance (membership) has been considered while degree of rejection is taken as one minus the degree of acceptance so that there is no degree of hesitation between the membership function. Furthermore, we cannot rule out any possibility on system failures including power systems, manual mistakes and human factors. Therefore, it is better to use IFS theory to evaluate the reliability of systems. IFS can solve this kind of problems when the experts just can assign the range of failure events under uncomfortable confidence level. As far as reliability field is concerned, IFSs have been proven to be highly useful to deal with uncertainty and vagueness, and a lot of work has been done by researchers [7, 8, 10–15, 17, 21] to develop and enrich the IFS theory.

## 1.2 Objectives of the Thesis

The objective of this thesis is to present some new methods for finding the reliability of some industrial systems. For this, system has been modeled with their system components and their corresponding functioning by using union and intersection operators. Further, the arithmetic operations on fuzzy quantities are widely used in the literature based on the extension principle and  $\alpha$ -level sets. But during their formulations, almost all the authors have considered the standard fuzzy union and intersection operators. Here, in this thesis, instead of using these operations for analyzing the system performance, we present a suitable approach in which a generalized t-norm and t-conorm operations have been

used for finding the system reliability. Furthermore, in real-life situation, it is difficult to analyze the fuzzy reliability of complex systems due to uncertainty present in failure data and systems' complexity. To deal with these types of problems and integrating the experts knowledge and experience in terms of possibilities of failure of bottom events, the objective of the thesis is to provide a flexible and more realistic approach to analyze the fuzzy reliability of complex systems under uncertain environment.

### 1.3 Structure of the Thesis

The present thesis is organized into four chapters including the present one that contains mainly the literature review. The rest of chapters are described below:

In **Chapter 2**, the basic and preliminaries related to the reliability theory, fuzzy set theory and intuitionistic fuzzy set theory and to be used in the subsequent chapters are given.

**Chapter 3** presents a concept of generalized t-norm operation based methodology for analyzing the behavior of the industrial systems. For this, data related to various component of the system are extracted from the various resources and hence fuzzy set theory has been used for handling the uncertainties in the data. After quantifying the uncertainties, generalized fuzzy union and intersection operations have been used for depicting the membership functions of various reliability parameters such as failure rate, repair time, MTBF, reliability, availability etc. Both Sensitivity analysis and performance analysis have been conducted for finding the most critical component of the system in order to increase the efficiency of the system. A washing unit of the paper mill, a complex repairable industrial system, has been taken to validate the approach algorithm.

In **Chapter 4**, an approach has been presented which deal with the intuitionistic fuzzy set (IFS) theory to analyze the reliability of series, series-parallel and mixed configuration structure. In this approach, uncertainties in the data are handled with the help of IFS and by integrating the experts knowledge and experience in terms of possibilities of failure of bottom events, a flexible and more realistic approach to analyze the fuzzy reliability of complex systems under uncertain environment has been presented.

# Chapter 2

## Preliminaries

This chapter presents some of the fundamental definitions and mathematical theory for reliability theory, fuzzy set, intuitionistic fuzzy set,  $\alpha$ -cuts, convex and normal fuzzy set, fuzzy numbers.

### 2.1 Reliability Aspects

This chapter introduces basic concepts related to reliability engineering and soft-computing knowledge of each of which is essential for the research in this area. Basically the purpose of reliability engineering is to develop methods and tools to evaluate and demonstrate reliability, maintainability, availability, and safety of systems and their components/equipments, as well as to support design/production engineers in building in these characteristics. These main aspects of reliability engineering of a system i.e. reliability, maintainability and availability are described briefly in the subsequent subsections.

#### 2.1.1 Reliability

Reliability is a characteristic of an item(component or system), expressed by the probability that the item (component/system) will perform its required function under given conditions for a stated time interval [2]. From a qualitative point of view, reliability can be defined as the ability of the item to remain functional. Quantitatively, reliability specifies the probability that no operational interruptions will occur during a stated time interval. Mathematically,if we define continuous random variable  $T$  to be the time to failure of the component/system;  $T \geq 0$ , then the basic reliability function  $R(t)$ , is defined for time to

failure of the system (or subsystem) as

$$R(t) = Pr(T \geq t) = 1 - \int_0^t f(u) du \quad (2.1.1)$$

where  $R(t) \geq 0$ ,  $R(0) = 1$ , and  $\lim_{t \rightarrow \infty} R(t) = 0$  and  $f(t)$  failure probability density function.

In addition to the probability function, there is another function, called the failure rate or hazard rate function, is often used in reliability. It provides an instantaneous (at time  $t$ ) rate of failure. The conditional probability of a failure in the time interval from  $t$  to  $t + \delta t$  given that the system has survived to time  $t$  is

$$Pr\{t \leq T \leq t + \delta t \mid T \geq t\} = \frac{R(t) - R(t + \delta t)}{R(t)} \quad (2.1.2)$$

then  $\frac{R(t) - R(t + \delta t)}{R(t)\delta t}$  is the conditional probability of failure per unit of time (failure rate). The rule of conditional probability therefore dictates that:

$$\lambda(t) = \frac{-dR(t)}{dt} \cdot \frac{1}{R(t)} = \frac{f(t)}{R(t)} \quad (2.1.3)$$

then  $\lambda(t)$  is known as the instantaneous hazard rate or failure rate function. Based on these hazard rate function, the reliability function can be derived as

$$R(t) = \exp \left[ - \int_0^t \lambda(u) du \right] \quad (2.1.4)$$

The mean time to failure(MTTF) of the system is defined as

$$MTTF = \int_0^{\infty} R(t)dt \quad (2.1.5)$$

### 2.1.2 Availability

Availability is defined as the probability of a product or system working satisfactorily at any given point of time when used under the given conditions of use [6]. Thus availability signifies the probability that the system is available and is working satisfactorily at a given point of time. Availability is a more meaningful parameter of performance of a maintained system than reliability. However, reliability and maintainability are related to availability and are two important design parameters in establishing the availability of equipment. Similar to the reliability function, it also gives a probability that a system

will be available to function at the given time  $t$ . At any given time  $t$ , the system will be operational if the following conditions are met:

$$A_s(t) = \frac{\mu_s}{\lambda_s + \mu_s} + \frac{\lambda_s}{\lambda_s + \mu_s} e^{-(\lambda_s + \mu_s)t} \quad (2.1.6)$$

where,  $\lambda_s$  and  $\mu_s$  are respectively the failure and repair rates of the system.

The steady state availability,  $A$ , of a system is the limit of the instantaneous availability function as time approaches to infinity ( $\infty$ ) and is represented by

$$A = \lim_{t \rightarrow \infty} A_s(t) = \frac{\text{MTBF}}{\text{MTBF} + \text{MTTR}} \quad (2.1.7)$$

where, MTTR and MTBF are the mean time to repair and the mean time between failures of the system/component respectively.

## 2.2 Basic concepts on fuzzy set theory

### 2.2.1 Classical Sets (Crisp Sets)

A classical set is a collection of distinct objects and is defined in such a way that the universe of discourse is split into two groups: members and nonmembers. Consider an object  $x$  in a crisp set  $A$ . This object  $x$  is either a member or a nonmember of the given set  $A$ . In case of crisp sets, no partial membership exists. This binary issue of membership can be represented mathematically by the indicator function,

$$\chi_A(x) = \begin{cases} 1 & \text{if } x \in A \\ 0 & \text{if } x \notin A \end{cases} \quad (2.2.1)$$

where  $\chi_A$  is the membership in set  $A$  for element  $x$  in the universe.

### 2.2.2 Fuzzy set theory

Zadeh extended and generalized the concept of crisp set by allowing the partial membership i.e. between 0 and 1 and named as Fuzzy sets [24]. In it, he defines the degree of membership function which takes values between 0 and 1 and represents degree of belongingness to that set which is denoted by  $[0, 1]$ , where 0 represent the “no” and 1 represent “yes”. Thus, based on it, a fuzzy set has been defined as a mapping from universe of discourse  $U$  to  $[0, 1]$  i.e.  $\tilde{A} = \{(x, \mu_{\tilde{A}}(x) \mid x \in U\}$  where  $\mu_{\tilde{A}}(x)$  is the degree of membership of  $x$  in fuzzy set  $\tilde{A}$ . Clearly  $\mu_{\tilde{A}}(x) \in [0, 1]$ .

### 2.2.3 $\alpha$ - cuts

$\alpha$ -cut is one of the most significant and extensively used concept in fuzzy set theory which was introduced by Zadeh [24]. When we want to exhibit an element  $x \in X$  that typically belongs to a fuzzy set  $\tilde{A}$ , we may demand that its membership value be greater than some threshold  $\alpha \in [0, 1]$ .

For a fuzzy set  $\tilde{A}$ ,

$$A_\alpha = \{x \mid \mu_{\tilde{A}}(x) > \alpha\}; \quad \alpha \in [0, 1)$$

$$A_\alpha = \{x \mid \mu_{\tilde{A}}(x) \geq \alpha\}; \quad \alpha \in [0, 1)$$

are called strong  $\alpha$ - cut and weak  $\alpha$ - cut respectively.

The  $\alpha$ -cut of fuzzy number  $(a, b, c)$  is defined below and shown graphically in Fig. 2.1 whose interval of confidence are defined are

$$A_\alpha = [a^{(\alpha)}, c^{(\alpha)}] = [(b - a)\alpha + a, -(c - b)\alpha + c] \quad (2.2.2)$$

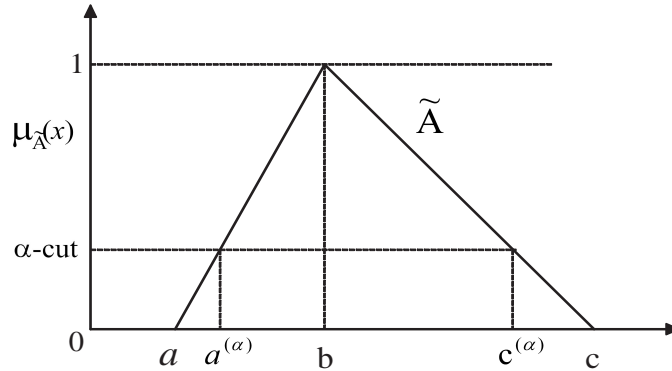

Figure 2.1: A fuzzy set  $\tilde{A}$

### 2.2.4 Convex fuzzy set

A fuzzy set  $\tilde{A} = \langle (x, \mu_{\tilde{A}}(x)) \mid x \in U \rangle$  is said to be convex fuzzy set [18] if the following inequality has been hold for  $x_1, x_2 \in X$

$$\mu_{\tilde{A}}(\lambda x_1 + (1 - \lambda)x_2) \geq \min[\mu_{\tilde{A}}(x_1), \mu_{\tilde{A}}(x_2)]$$

If above inequality does not hold then that it is said to be non-convex fuzzy set.

### 2.2.5 Normal fuzzy set

A fuzzy set is said to be normal fuzzy set [18] if there exist at least one element in the universal set  $U$  such that their corresponding membership function is unity.

### 2.2.6 Fuzzy number

A convex, normal membership function on the real line  $\mathbb{R}$  is called a fuzzy number [18] i.e., if its membership function is piecewise continuous and there exist at least one  $x_0 \in U$  such that  $\mu_{\tilde{A}}(x_0) = 1$ . The corresponding membership function defined on  $[a, b] \neq \emptyset$  is given as

$$\mu_{\tilde{A}}(x) = \begin{cases} f(x) & ; \quad x \in (-\infty, a) \\ 1 & ; \quad x = [a, b] \\ g(x) & ; \quad x \in (b, \infty) \\ 0 & ; \quad \text{otherwise} \end{cases}$$

where  $f$  and  $g$  are monotonic, continuous from the right and left, nondecreasing and nonincreasing functions such that  $f(x) = 0$  for  $x \in (-\infty, \omega_1)$  and  $g(x) = 0$  for  $x \in (\omega_2, \infty)$ .

A fuzzy number  $A = \langle a, b, c, d \rangle$  is called a trapezoidal fuzzy number if its membership function  $\mu_A$  is given by

$$\mu_A(x) = \begin{cases} \frac{x-a}{b-a} & ; \quad a \leq x < b \\ 1 & ; \quad b \leq x < c \\ \frac{d-x}{d-c} & ; \quad c \leq x < d \\ 0 & ; \quad \text{otherwise} \end{cases}$$

The  $\alpha$ - cut of the number  $A = \langle a, b, c, d \rangle$  is the closed interval

$$A_\alpha = [A_\alpha^L, A_\alpha^R] = [a + \alpha(b - a), d - \alpha(d - c)] \quad , \quad \alpha \in (0, 1]$$

## 2.3 Intuitionistic fuzzy set theory

An intuitionistic fuzzy set (IFS)  $A$  [1] in a finite universe of discourse  $X = \{x_1, x_2, \dots, x_n\}$  is given by

$$A = \{\langle x, \mu_A(x), \nu_A(x) \rangle \mid x \in X\}$$

where  $\mu_A(x)$  and  $\nu_A(x)$  respectively the grades of membership and non-membership of an element  $x$  with the conditions that  $0 \leq \mu_A(x), \nu_A(x) \leq 1$ , and  $\mu_A(x) + \nu_A(x) \leq 1$ . IFS reduces to fuzzy set when  $\pi_A(x) = 0, \forall x \in X$ . A typical illustration of a IFS set  $\tilde{A}$  is shown in Fig. 2.2.

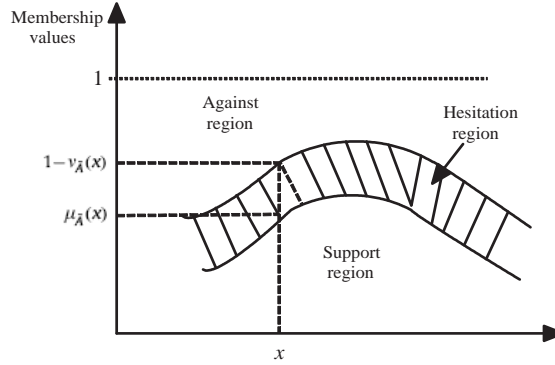

Figure 2.2: Representation of a IFS set

For example, if  $\mu_A(x) = 0.6, \nu_A(x) = 0.3$  then  $\pi_A(x) = 0.1$  for some  $x$  which implies that  $x$  belong to IFS  $A$  and accept evidence is 0.6; decline evidence is 0.3 and hesitation is 0.1.

### 2.3.1 $\alpha$ - level set or cut of an IFS

Let  $\alpha \in [0, 1]$  then an  $\alpha$ - level set or  $\alpha$ - cut generate by IFS  $A$  is denoted by  $A_\alpha$  and is defined mathematically as

$$A_{(\alpha)} = \{x \in X : \mu_{\tilde{A}}(x) \geq \alpha\} \quad (2.3.1)$$

while for non-membership function, it is defined as

$$A_{(\alpha)} = \{x \in X : 1 - \nu_{\tilde{A}}(x) \geq \alpha\} \quad (2.3.2)$$

where  $\alpha$  is the parameter in the range  $0 \leq \alpha \leq 1$ .

### 2.3.2 Convex intuitionistic fuzzy set

An IFS set  $\tilde{A}$  in universe  $X$  is said to be convex if and only if

- (i) Membership functions of  $\mu_{\tilde{A}}(x)$  of  $\tilde{A}$  is fuzzy - convex i.e.

$$\mu_{\tilde{A}}(\lambda x_1 + (1 - \lambda)x_2) \geq \min(\mu_{\tilde{A}}(x_1), \mu_{\tilde{A}}(x_2)) \quad \forall x_1, x_2 \in X, \quad 0 \leq \lambda \leq 1$$

(ii) Non-membership functions of  $\nu_{\tilde{A}}(x)$  of  $\tilde{A}$  is fuzzy - concave i.e.

$$\nu_{\tilde{A}}(\lambda x_1 + (1 - \lambda)x_2) \leq \max(\nu_{\tilde{A}}(x_1), \nu_{\tilde{A}}(x_2)) \quad \forall x_1, x_2 \in X, \quad 0 \leq \lambda \leq 1$$

### 2.3.3 Normal IFS

An IFS  $\tilde{A}$  is said to be normal if there exist at least two points  $x_1, x_2 \in X$  such that  $\mu_{\tilde{A}}(x_1) = 1$  and  $\nu_{\tilde{A}}(x_2) = 0$ .

### 2.3.4 Intuitionistic fuzzy number (IFN)

An intuitionistic fuzzy subset  $\tilde{A} = \{ \langle x, \mu_{\tilde{A}}(x), \nu_{\tilde{A}}(x) \rangle \mid x \in R \}$  of the real line  $R$  is called an IFN if

- (i)  $\tilde{A}$  is convex and normal.
- (ii)  $\mu_{\tilde{A}}$  is upper semi-continuous and  $\nu_{\tilde{A}}$  is lower semi-continuous.
- (iii)  $\text{Supp}\tilde{A} = \{x \in X \mid \mu_{\tilde{A}}(x) < 1\}$  is bounded.

Let  $\tilde{A}$  be vague set denoted by  $\tilde{A} = \langle [(a, b, c); \mu, \nu] \rangle$ , where  $a, b, c \in \mathbb{R}$  then the set  $\tilde{A}$  is said to be triangular vague number if its membership function is given by

$$\mu_{\tilde{A}}(x) = \begin{cases} \mu \times \left( \frac{x-a}{b-a} \right) & ; \quad a \leq x < b \\ \mu & ; \quad x = b \\ \mu \times \left( \frac{c-x}{c-b} \right) & ; \quad b \leq x < c \\ 0 & ; \quad \text{otherwise} \end{cases} \quad ; \quad \nu_{\tilde{A}}(x) = \begin{cases} \nu \times \left( \frac{b-x}{b-a} \right) & ; \quad a \leq x < b \\ 0 & ; \quad x = b \\ \nu \times \left( \frac{x-b}{c-b} \right) & ; \quad b \leq x < c \\ \nu & ; \quad \text{otherwise} \end{cases}$$

where the parameter  $b$  gives the modal values of  $A$  and  $a, c$  are the lower and upper bounds of available area for the evaluation data.  $\alpha$ -cuts of it has been defined as

$$A^{(\alpha)} = [a^{(\alpha)}, c^{(\alpha)}] = \left[ a + \frac{\alpha}{\mu}(b-a), \quad c - \frac{\alpha}{\mu}(c-b) \right] \quad (2.3.3)$$

$$\text{and } A_{(\alpha)} = [a_{(\alpha)}, c_{(\alpha)}] = \left[ a + \frac{\alpha}{\nu}(b-a), \quad c - \frac{\alpha}{\nu}(c-b) \right] \quad (2.3.4)$$

where  $a^{(\alpha)}, a_{(\alpha)}$  are the increasing functions and  $c^{(\alpha)}, c_{(\alpha)}$  are decreasing functions of  $0 \leq \alpha \leq 1$ .

## 2.4 t-Norms & t-Conorms

### 2.4.1 Fuzzy Intersection: t-Norms

A fuzzy intersection (t-Norm)  $T$ , is a binary operation on the unit interval i.e., a function of the form [18]

$$T : [0, 1] \times [0, 1] \rightarrow [0, 1]$$

defined for all  $x \in X$  by

$$(A \cap B)(x) = T[A(x), B(x)] \quad (2.4.1)$$

satisfies the following axioms for all  $a, b, d \in [0, 1]$ .

- Axiom 1:  $T(a, 1) = a$  (Boundary condition)
- Axiom 2:  $b \leq d$  implies  $T(a, b) \leq T(a, d)$  (Monotonicity)
- Axiom 3:  $T(a, b) = T(b, a)$  (Commutativity)
- Axiom 4:  $T(a, T(b, d)) = T(T(a, b), d)$  (Associativity)

These four axioms are called the axiomatic skeleton for fuzzy intersections. A class of fuzzy intersection (t-norms) is obtained by if the fuzzy intersection also satisfies the additional three axioms i.e.,

- Axiom 5:  $T$  is a continuous function. (Continuity)
- Axiom 6:  $T(a, a) < a$  (Subidempotency)
- Axiom 7:  $a_1 < a_2$  and  $b_1 < b_2$  implies  $T(a_1, b_1) < T(a_2, b_2)$  (Strict monotonicity)

A t-norm function  $T$  is called Archimedean t-norm if it is continuous and, for all  $x \in [0, 1]$ ,  $T(x, x) < x$ . If for all  $x, y \in (0, 1)$ ,  $T(x, y)$  is strictly increasing,  $T(x, y)$  can be called strictly Archimedean t-norm.

**Result 2.4.1.** *Let  $T$  be binary operation on the unit interval. Then  $T$  is an Archimedean t-norm if and only if there exists a decreasing generator  $g$  such that*

$$T(a, b) = g^{-1}(g(a) + g(b)) \quad \forall a, b \in [0, 1]$$

### 2.4.2 Fuzzy Unions: t-Conorms

A fuzzy union (t-conorm)  $S$ , is a binary operation on the unit interval i.e., a function of the form [18]

$$S : [0, 1] \times [0, 1] \rightarrow [0, 1]$$

defined for all  $x \in X$  by

$$(A \cup B)(x) = S[A(x), B(x)] \quad (2.4.2)$$

satisfies the following axioms for all  $a, b, d \in [0, 1]$ .

- Axiom 1:  $S(a, 0) = a$  (Boundary condition)
- Axiom 2:  $b \leq d$  implies  $S(a, b) \leq S(a, d)$  (Monotonicity)
- Axiom 3:  $S(a, b) = S(b, a)$  (Commutativity)
- Axiom 4:  $S(a, T(b, d)) = S(S(a, b), d)$  (Associativity)

These four axioms are called the axiomatic skeleton for fuzzy union. A class of fuzzy union (t-conorms) is obtained by if the fuzzy union also satisfies the additional three axioms i.e.,

- Axiom 5:  $S$  is a continuous function. (Continuity)
- Axiom 6:  $S(a, a) < a$  (Subidempotency)
- Axiom 7:  $a_1 < a_2$  and  $b_1 < b_2$  implies  $S(a_1, b_1) < S(a_2, b_2)$  (Strict monotonicity)

A t-conorm function  $S$  is called Archimedean t-conorm if it is continuous and, for all  $x \in [0, 1]$ ,  $S(x, x) < x$ . If for all  $x, y \in (0, 1)$ ,  $S(x, y)$  is strictly decreasing,  $S(x, y)$  can be called strictly Archimedean t-conorm.

**Result 2.4.2.** *Let  $S$  be binary operation on the unit interval. Then  $S$  is an Archimedean t-conorm if and only if there exists a increasing generator  $h$  such that*

$$S(a, b) = h^{-1}(h(a) + h(b)) \quad \forall a, b \in [0, 1]$$

It is well know that a strictly Archimedean t-norm is generated by its additive generator  $g$  as  $T(x, y) = g^{-1}(g(x) + g(y))$  and  $g$  is strictly decreasing function:  $[0, 1] \rightarrow [0, \infty)$  such that  $g(1) = 0$ . Let  $h(t) = g(1 - t)$ , and then Archimedean t-conorm can be expressed as  $S(x, y) = h^{-1}(h(x) + h(y))$ . If the generator  $g$  is assigned different forms, then we have

Case 1: If  $g(t) = -\log(t)$ , then  $h(t) = -\log(1-t)$ ,  $g^{-1}(t) = e^{-t}$ , and  $h^{-1}(t) = 1 - e^{-t}$ .

Therefore, Algebraic t-conorm and t-norm can be obtained:  $S(x, y) = x + y - xy$  and  $T(x, y) = xy$ .

Case 2: If  $g(t) = \log\left(\frac{2-t}{t}\right)$ , then Algebraic t-conorm and t-norm can be obtained:  $S(x, y) = \frac{(1+x)(1+y) - (1-x)(1-y)}{(1+x)(1+y) + (1-x)(1-y)}$  and  $T(x, y) = \frac{2xy}{(2-x)(2-y) + xy}$ .

## Chapter 3

# Reliability analysis of an industrial system using t-norm operations

The objective of this chapter is to present a new approach for analyzing the reliability of an industrial systems by using generalized t-norm and t-conorm operations and illustrated with a case study of washing unit of a paper mill.

### 3.1 Introduction

Today in real-world decision, an uncertainty play a dominant role during the analysis and hence a billion of dollars are being spent in maintaining the performance of the system by designing a reliable system and/or products. The primary objective of the system analyst is to increase the reliability and/or availability of the system by choosing the proper maintenance actions. For reliability, this has become an eagerly topic in the field of industrial engineering to maintain the components of the system for a longer period of survival so as to increase the production of the system [9, 16]. However, if the analysis has been taken out without handling the uncertainties, then the result will surely give a false opinion of the decision makers. To deal with such uncertainties, fuzzy set theory [24] is one of the powerful tools for handling the vagueness and used by the various researchers [5, 7, 8, 10–12, 15, 17] in the field of reliability analysis by taking triangular linear membership functions.

In this chapter, a concept of generalized t-norm operation based methodology for analyzing the behavior of the industrial systems has been presented. For this, data related

to various component of the system are extracted from the various resources and hence fuzzy set theory has been used for handling the uncertainties in the data. After quantifying the uncertainties, generalized fuzzy union and intersection operations have been used for depicted the membership functions of various reliability parameters such as failure rate, repair time, MTBF, reliability, availability etc.

## 3.2 Methodology

An approach has been presented by taking the different fuzzy numbers for analyzing the behavior of the system under the following restrictions.

- (i) component parameters are independent.
- (ii) maintenance facility is separate for each component.
- (iii) after repairs, component is assumed to be as new.
- (iv) standby components are of same nature as of active units.

Based on these assumptions, the methodology for conducting the behavior analysis are summarized in the following four steps as follows:

- (Step 1:) The approach has been started from the information extraction phase in which plant personnel may extract the information related to system components' in the form of failure rates  $\lambda_i$ 's and repair times  $\tau_i$ 's of each component either from the sheets or from their personal experiences.
- (Step 2:) The obtained information from Step 1 are generally out of date or imprecise due to lack of proper update or by human errors. So in order to quantify the uncertainties in the data, this crisp data is converted into the triangular form of the fuzzy numbers with some known spread say 15%, 25% and 50% as suggested by the decision makers towards the data.
- (Step 3:) Corresponding to  $\alpha$ - cuts obtained from the above step have been used for finding the overall system fuzzy numbers by using fuzzy intersection and unions norms operations as given in Eqs. (2.4.1) and (2.4.2) respectively. Based on

it, various reliability indices, listed in Table 3.1, are quantitatively in terms of evaluating the membership functions at different levels of  $\alpha$ - cuts.

Table 3.1: Some Reliability Parameters

Parameters	Expressions
Failure rate	$MTTF_s = \frac{1}{\lambda_s}$
Repair time	$MTTR_s = \frac{1}{\mu_s} = \tau_s$
Mean Time Between Failures (MTBF)	$MTBF_s = MTTF_s + MTTR_s$
Reliability	$R_s = e^{-\lambda_s t}$
Availability	$A_s = \frac{\mu_s}{\lambda_s + \mu_s} + \frac{\lambda_s}{\lambda_s + \mu_s} e^{-(\lambda_s + \mu_s)t}$
Expected numbers of failures (ENOF)	$W_s(0, t) = \frac{\lambda_s \mu_s t}{\lambda_s + \mu_s} + \frac{\lambda_s^2}{(\lambda_s + \mu_s)^2} [1 - e^{-(\lambda_s + \mu_s)t}]$

(Step 4:) After fuzzifying the data, it is necessary to decode it in the form of crisp number so as to implement their results in the real systems. For this, center of gravity (COG) method has been used as it gives the mean of the membership function in the interval  $[x_1, x_2]$ . Mathematically, it is represented as

$$COG = \frac{\int_{x_1}^{x_2} x \cdot \mu_A(x) dx}{\int_{x_1}^{x_2} \mu_A(x) dx} \quad (3.2.1)$$

### 3.3 Case study

In this section, a brief description of the system i.e. a paper mill which is a large capital oriented engineering systems, comprising of units/subsystems namely, feeding, pulping, washing, screening, bleaching, forming, dryer and press, arranged in predefined configuration. Out of it, the washing unit is one of the most important functioning unit of the mill. The brief description of the system is summarized as below.

#### 3.3.1 System description

The Washing of prepared pulp is done in three to four stages, to get it free from blackness and to prepare the fine fibers of the pulp. The system consists of four main subsystems, defined as:

- **Filter (A):** It consists of single unit which is used to drain black liqueur from the cooked pulp.

- **Cleaners (B):** In this subsystem three units of cleaners are arranged in parallel configuration. Each unit may be used to clean the pulp by centrifugal action. Failure of anyone will reduce the efficiency of the system as well as quality of paper.
- **Screeners (C):** Herein two units of screeners are arranged in series. These are used to remove oversized, uncooked and odd shaped fibers from pulp through straining action. Failure of any one will cause the complete failure of the system.
- **Deckers (D):** Two units of deckers are arranged in parallel configuration. The function of deckers is to reduce the blackness of pulp. Complete failure of decker occurs when both the components will fail.

The systematic diagram of the system are shown in Fig. 3.1.

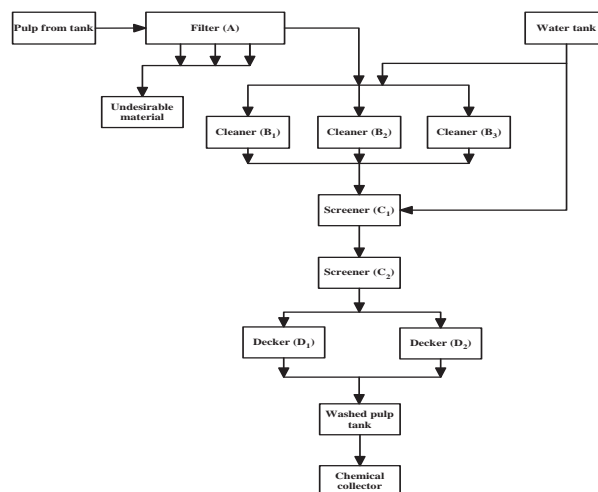

Figure 3.1: Systematic diagram of Washing system

### 3.3.2 Behavior analysis

The procedure steps used for conducting the analysis by using proposed methodology are given as below.

- (Step 1:) Under the information extraction phase, the data related to main components' of the system are extracted in the form of failure rates ( $\lambda_i$ 's) and repair times ( $\tau_i$ 's) and are summarized in Table 3.2 along with their level of significance.

Table 3.2: Input data for the main components of the Washing system

Components→	Filter	Cleaners	Screeners	Deckers
	( $i = 1$ )	( $i = 2, 3, 4$ )	( $i = 5, 6$ )	( $i = 7, 8$ )
Failure rate $\lambda_i$ (hrs <sup>-1</sup> )	$1 \times 10^{-3}$	$3 \times 10^{-3}$	$5 \times 10^{-3}$	$5 \times 10^{-3}$
Repair time $\tau_i$ (hrs)	3	2	3	3

(Step 2:) As the obtained data are imprecise or uncertain and hence contain some sort of uncertainties. To handle these uncertainties, the obtained (crisp) data are fuzzified into TFNs with some known spread or support,  $\pm 15\%$  (also at  $\pm 25\%$ ,  $\pm 50\%$ ) on both sides of data, as suggested by system analyst/ decision makers and hence their generalized fuzzy numbers are arranged in Table 3.3.

Table 3.3: Generalized Triangular fuzzified data for the main components system

Components	Failure rate	Repair time
↓	$\lambda_i$ (hrs <sup>-1</sup> )	$\tau_i$ (hrs)
Filter ( $i = 1$ )	(0.0085, 0.001, 0.00115; 0.65)	(2.55, 3, 3.45; 0.65)
Cleaners ( $i = 2, 3, 4$ )	(0.00255, 0.003, 0.00345; 0.75)	(1.70, 2, 2.30; 0.75)
Screeners ( $i = 5, 6$ )	(0.00425, 0.005, 0.00575; 0.80)	(2.55, 3, 3.45; 0.80)
Deckers ( $i = 7, 8$ )	(0.00425, 0.005, 0.00575; 0.90)	(2.55, 3, 3.45; 0.90)

(Step 3:) Based on these data and the minimal cut set of the system obtained as  $\{A\}$ ,  $\{B_1 B_2 B_3\}$ ,  $\{C_1\}$ ,  $\{C_2\}$  and  $\{D_1 D_2\}$ , the system expression for systems' failure rate ( $\lambda_s$ ) and repair time ( $\tau_s$ ) are obtained using the results as below

$$\lambda_s = \lambda_1 \cup (\lambda_2 \cap \lambda_3 \cap \lambda_4) \cup (\lambda_5 \cup \lambda_6) \cup (\lambda_7 \cap \lambda_8)$$

$$\tau_s = \frac{(\lambda_1 \cap \tau_1) \cup (\lambda_2 \cap \lambda_3 \cap \lambda_4)(\tau_2 \cap \tau_3 \cap \tau_4) \cup (\lambda_5 \cap \tau_5) \cup (\lambda_6 \cap \tau_6) \cup (\lambda_7 \cap \lambda_8)(\tau_7 \cap \tau_8)}{\lambda_s}$$

Here, we take fuzzy intersection ( $\cap$ ) and fuzzy union ( $\cup$ ) as the t-norms and t-conorms respectively defined by Eqs. (2.4.1) and (2.4.2) respectively. In this study, we take  $g(t) = \log((2-t)/t)$  and then based on it, the various reliability parameters have been computed at different confidence levels ranging from 0 to 1 at the mission time  $t = 10$ (hrs) with left and right spread. These computed results are depicted graphically in Fig. 3.2 for  $\pm 15\%$  spreads along with the existing techniques results while their corresponding value of each  $\alpha$ - cut are tabulated in Table 3.4.

Table 3.4: Membership values for various reliability parameters values

$\alpha$	Failure rate						Repair time						ENOF					
	Existing [17, 19]		proposed		Existing [17, 19]		proposed		Existing [17, 19]		proposed		Existing [17, 19]		proposed			
	L	R	L	R	L	R	L	R	L	R	L	R	L	R	L	R		
0	0.0094	0.0129	0.0094	0.0127	1.8604	4.6638	2.5484	3.4468	0.0893	0.1299	0.0901	0.1255						
0.2	0.0098	0.0125	0.0097	0.0123	2.0501	4.2678	2.6384	3.3572	0.0932	0.1255	0.0936	0.1218						
0.4	0.0101	0.0122	0.0100	0.0120	2.2554	3.9044	2.7284	3.2676	0.0971	0.1212	0.0970	0.1183						
0.6	0.0105	0.0118	0.0103	0.0117	2.4778	3.5704	2.8184	3.1779	0.1010	0.1170	0.1005	0.1146						
0.8	0.0108	0.0115	0.0107	0.0113	2.7187	3.2629	2.9084	3.0881	0.1049	0.1129	0.1040	0.1111						
1.0	0.0112	0.0112	0.0110	0.0110	2.9798	2.9798	2.9983	2.9983	0.1089	0.1089	0.1075	0.1075						
$\alpha$	Existing [17, 19]		proposed		Existing [17, 19]		proposed		Existing [17, 19]		proposed		Existing [17, 19]		proposed			
	L	R	L	R	L	R	L	R	L	R	L	R	L	R	L	R		
0	79.5075	110.5706	81.5059	110.3494	0.8792	0.9099	0.8810	0.9107	0.9434	0.9890	0.9586	0.9789						
0.2	81.8502	106.4923	83.7216	106.6119	0.8822	0.9068	0.8840	0.9077	0.9494	0.9849	0.9607	0.9769						
0.4	84.3252	102.6870	86.0530	103.1146	0.8853	0.9037	0.8869	0.9047	0.9548	0.9809	0.9629	0.9750						
0.6	86.9438	99.1286	88.5103	99.8346	0.8883	0.9006	0.8899	0.9017	0.9598	0.9770	0.9650	0.9731						
0.8	89.7184	95.7940	91.1045	96.7516	0.8914	0.8976	0.8928	0.8987	0.9645	0.9730	0.9670	0.9711						
1.0	92.6632	92.6632	93.8481	93.8481	0.8945	0.8945	0.8958	0.8958	0.9688	0.9688	0.9691	0.9691						

L: left membership values ; R: right membership values

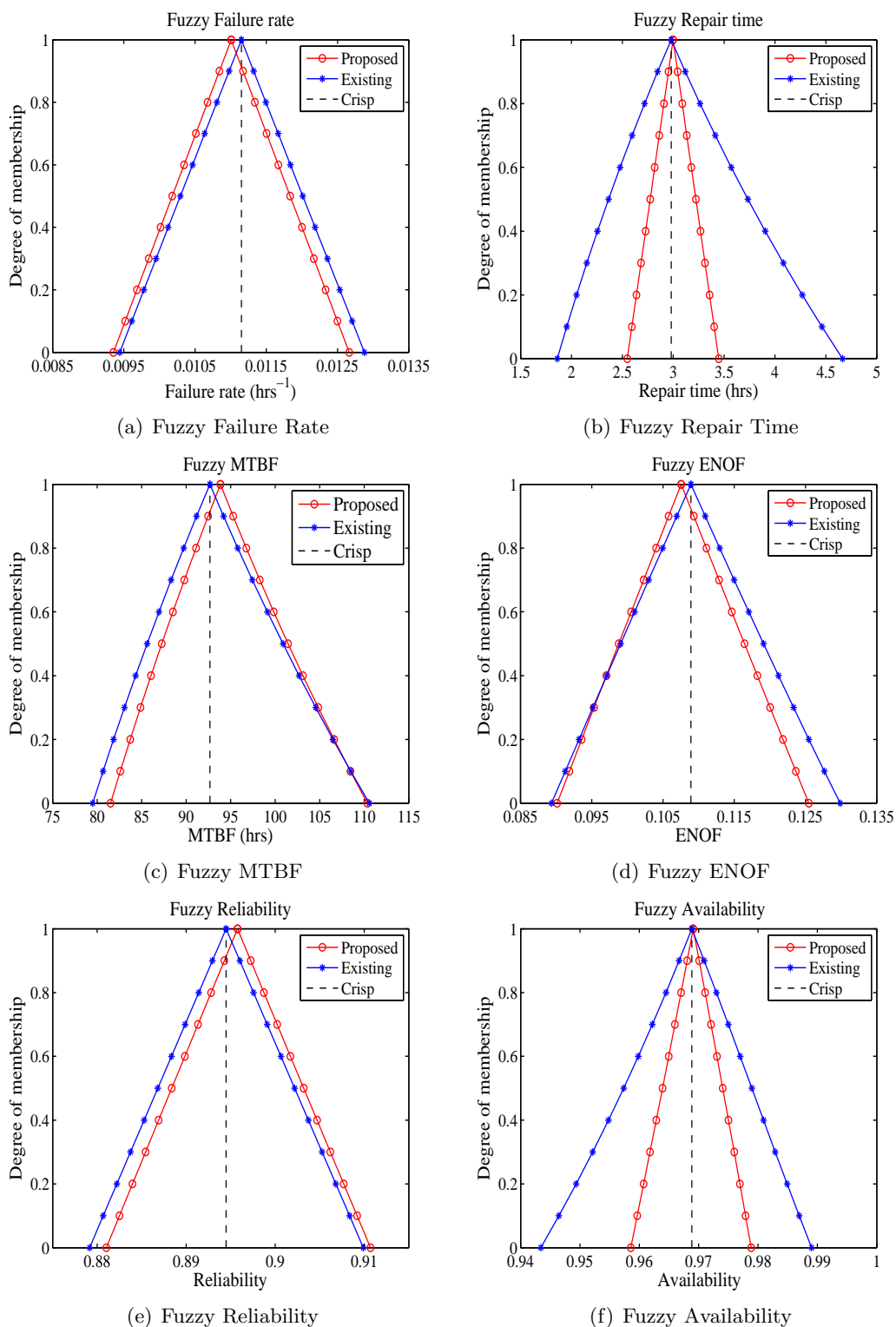

Figure 3.2: Fuzzy Reliability Indices Plots for Washing system

(Step 4:) As for implementing these results in real-life situation then it is necessary that these fuzzified valued should be converted to crisp values as most of the actions implemented by the human or machines are binary or crisp in nature. Thus for this, COG method is used and the corresponding crisp and defuzzified values of reliability indices at  $\pm 15\%$ ,  $\pm 25\%$  and  $\pm 50\%$  spreads are computed and compared with the existing results are shown in Table 3.5. It shows that when uncertainty level in the form of spread increases from  $\pm 15\%$  to  $\pm 25\%$  and further  $\pm 50\%$ , the variation in defuzzified values for almost all the reliability indices are not so much as shown by results of other techniques.

Table 3.5: Crisp and defuzzified values of the system

Reliability parameters	Crisp values	Defuzzified values at spread		
		$\pm 15\%$	$\pm 25\%$	$\pm 50\%$
Failure rate	0.011150	I <sup>a</sup> : 0.011155	0.011164	0.011207
		II <sup>b</sup> : 0.011008	0.011010	0.011021
Repair time	2.979753	I: 3.121068	3.387354	4.968921
		II: 2.997908	2.997362	3.000397
MTBF	92.663246	I: 93.850876	96.08055	109.1546
		II: 94.886048	96.84032	108.2938
Reliability	0.894488	I: 0.894508	0.894545	0.894718
		II: 0.895818	0.895911	0.896326
Availability	0.968846	I: 0.967489	0.965238	0.958872
		II: 0.968889	0.968568	0.967002
ENOF	0.108919	I: 0.109248	0.109969	0.117147
		II: 0.107672	0.107897	0.108997

<sup>a</sup> : Existing [17, 19]

<sup>b</sup> : proposed

### 3.3.3 Performance analysis

In order to save money, manpower and time, current conditions of the systems should be changed according to their effectiveness program. For this, it is necessary to find the components of the system on which more attention should be given for increasing the performance and productivity of the system. To conduct such type of analysis, an investigation has been done on system availability index for finding the most critical component, as per preferential order, of the system by varying their failure rate and repair time simultaneously and fixing the failure rate and repair time of other components' at the same time.

The results corresponding to main components of the washing system are obtained graphically and shown through the surface plot in Fig. 3.3 which contains four subplots corresponding to four main components of the system. The magnitude of effect of variation in failure rates and repair times of various subsystems of the system on its performance is summarized in Table 3.6. On the basis of these results, it can be analyzed that for improving the performance of the system, more attention should be given to the components as per the preferential order; decker, screener, cleaner, filter.

Table 3.6: Variation of Failure rates and Repair times on the System Availability of Washing System

Components	Range of Failure rate (failures/hrs)	Range of Repair time (hrs)	Availability Index	
			Min	Max
Filter	0.00085 - 0.00115	2.5500 - 3.4500	0.98980625	0.99365935
Cleaner	0.00255 - 0.00345	1.7000 - 2.3000	0.97695681	0.98717642
Screener	0.00425 - 0.00575	2.5500 - 3.4500	0.95497551	0.96894240
Decker	0.00425 - 0.00575	2.5500 - 3.4500	0.94621405	0.96894240

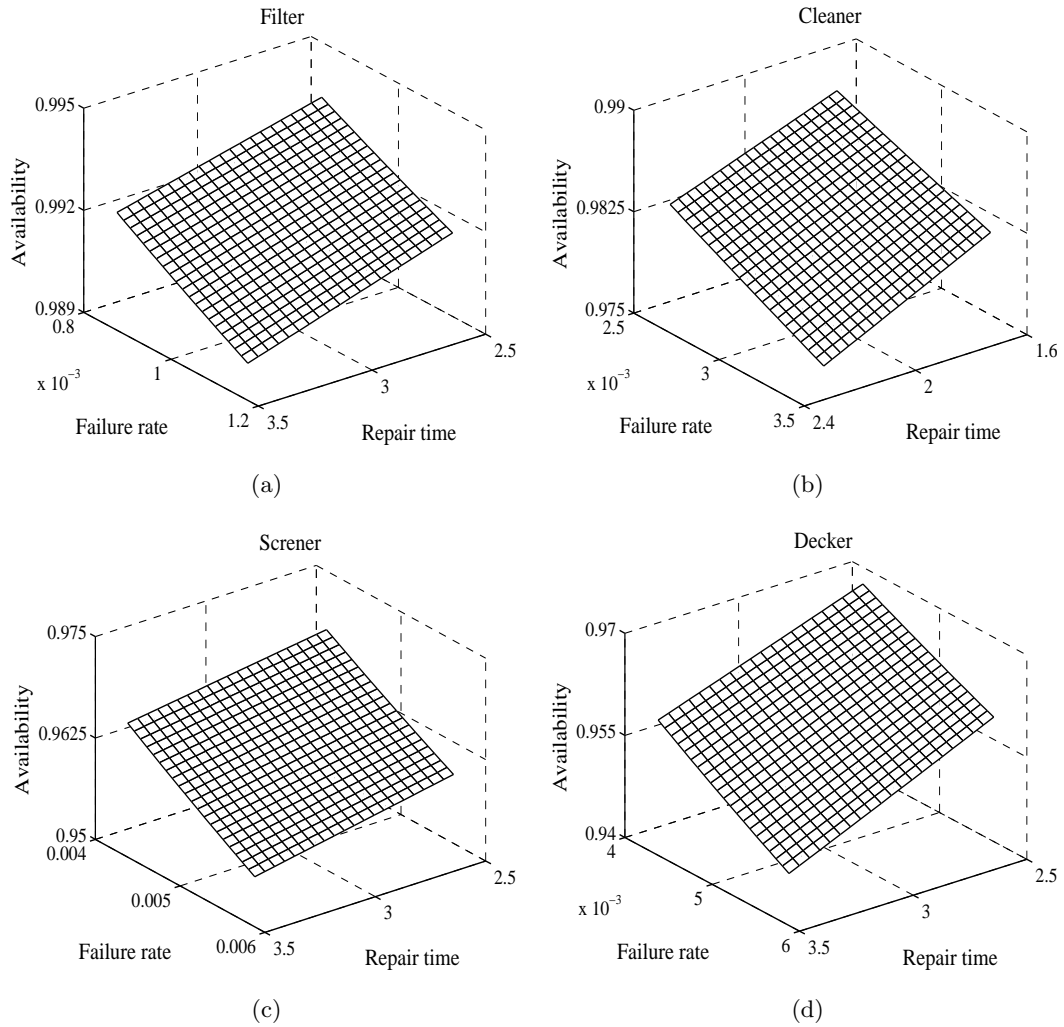

Figure 3.3: Effect of varying Failure rate and Repair time on Washing System Availability

### 3.4 Conclusion

The objective of this chapter is to present a novel technique for analyzing the behavior of the system using the generalized operations of t-norm and t-conorm operations. For this, a case study of washing unit, from a complex repairable system of paper mill, has been taken for illustration. In it, information related to various component of the system are collected from different phases and fuzzy set theory has been used for handling the uncertainties in the data. After quantifying the uncertainties, generalized t-norms and t-conorms operation have been used for analyzing the various reliability parameters at

different levels of significance levels. Their corresponding results have been compared with the existing techniques results and shows their conservative in nature. For ranking the critical components of the system on the basis of their performance on which more attention need to be given to save money, manpower and time, an analysis has been done on system availability index. In this analysis, effects of varying failure rate and repair time of main components of all the subsystem of the paper mill on system availability are analyzed by varying failure and repair rate parameters of each of the constituting components separately and fixing failure rate and repair time of other components at the same time. The corresponding computed results have been shown graphically and their computed ranges are summarized in tabular form which indicate the effects of taking wrong decisions on the system's behavior. Major advantage of this analysis is that by varying individual component's failure rate and repair time, the impact on the system's performance can be analyzed effectively to plan the future course of action.

## Chapter 4

# Fuzzy system reliability analysis by the use of norm operations on intuitionistic fuzzy number

This chapter addresses the fuzzy system reliability analysis using different types of IFNs. In the present chapter, a new algorithm has been introduced to construct the membership and non-membership function of fuzzy reliability of a system with components following different types of intuitionistic fuzzy failure rates. Here failure rates of components of the system are constant and represent by different types of IFNs. To construct the membership and non-membership functions of intuitionistic fuzzy reliability, a compensatory “AND” and “OR” operators have been introduced by using the t-norm and t-conorm operations. Using these, intuitionistic fuzzy reliabilities of series, series-parallel and mixed configuration system have been computed.

### 4.1 Overview

Among the great variety of fuzzy complements, intersection, and unions, the standard fuzzy operations possess certain properties that give them a special significance. Furthermore, the standard fuzzy intersection (min operator) produces for any given fuzzy sets the largest fuzzy set from among those produced by all possible fuzzy intersections (t-norms). On the contrary, the standard fuzzy union (max-operator) produces the smallest fuzzy set among the fuzzy sets produced by all possible fuzzy unions (t-conorms). Furthermore, in real-life situation, it is difficult to analyze the fuzzy reliability of complex systems due

to uncertainty present in failure data and systems' complexity. To deal with these types of problems and integrating the experts knowledge and experience in terms of possibilities of failure of bottom events, the objective of the chapter is to provide a flexible and more realistic approach to analyze the fuzzy reliability of complex systems under uncertain environment.

## 4.2 Compensatory Operator

### 4.2.1 'AND' operator

Let  $A$  and  $B$  be two fuzzy numbers then the failure possibility  $F(A \cap B)$  for  $A > 0$  and  $B > 0$  can be defined using compensatory *AND* operator for the parameter  $\gamma \in [0, 1]$  as

$$F(A \cap B) = (T(A, B))^{1-\gamma}(1 - S(A, B))^\gamma$$

where  $T, S$  represents the t-norm and t-conorm respectively of the two fuzzy set  $A$  and  $B$  defined in Eqs. (2.4.1) and (2.4.2) respectively.

Consider two positive TFNs  $A = (a_1, a_2, a_3)$  and  $B = (b_1, b_2, b_3)$  and algebraic product t-norm (intersection) and t-conorm (union) defined by  $T(x, y) = xy$  and  $S(x, y) = 1 - (1 - x)(1 - y)$  respectively then failure possibility  $F(A \cap B)$  is given for parameter  $\gamma \in [0, 1]$  as

$$\begin{aligned} F(A \cap B) &= (F(A)F(B))^{1-\gamma}[1 - (1 - F(A))(1 - F(B))]^\gamma \\ &= ((a_1, a_2, a_3)(b_1, b_2, b_3))^{1-\gamma}[1 - (1 - (a_1, a_2, a_3))(1 - (b_1, b_2, b_3))]^\gamma \\ &= (a_1b_1, a_2b_2, a_3b_3)^{1-\gamma}[1 - (1 - a_3, 1 - a_2, 1 - a_1)(1 - b_3, 1 - b_2, 1 - b_1)]^\gamma \end{aligned}$$

### 4.2.2 'OR' operator

Let  $A$  and  $B$  be two fuzzy numbers then the failure possibility  $F(A \cup B)$  for  $A > 0$  and  $B > 0$  can be defined using compensatory *OR* operator as

$$F(A \cup B) = S(A, B)$$

Consider two positive TFNs  $A = (a_1, a_2, a_3)$  and  $B = (b_1, b_2, b_3)$  and algebraic product t-norm (intersection) and t-conorm (union) defined by  $T(x, y) = xy$  and  $S(x, y) = 1 - (1 -$

$x)(1 - y)$  respectively then failure possibility  $F(A \cup B)$  is given as

$$\begin{aligned} F(A \cup B) &= 1 - (1 - F(A))(1 - F(B)) \\ &= 1 - (1 - (a_1, a_2, a_3))(1 - (b_1, b_2, b_3)) \\ &= 1 - (1 - a_3, 1 - a_2, 1 - a_1)(1 - b_3, 1 - b_2, 1 - b_1) \end{aligned}$$

### 4.3 Illustrative Example

The above mentioned operator has been illustrated through analyzing the system reliability of the series, parallel and series-parallel systems, where failure rates of the components of a systems are represented by different types of vague sets defined on the universe of discourse  $[0, 1]$ .

#### 4.3.1 Series System

Consider a series system having ' $n$ ' components connected in series configuration as shown in Fig. 4.1. Assume that the failure rate of ' $n$ ' components are represented by different IFNs  $\lambda_1, \lambda_2, \dots, \lambda_n$  and reliability of ' $n$ ' components with intuitionistic fuzzy failure rates  $\lambda_1, \lambda_2, \dots, \lambda_n$  are  $R_1, R_2, \dots, R_n$  respectively at time  $t$ , then the reliability of the system at time  $t$  using compensatory operator is

$$R_s(t) = \left( \prod_{i=1}^n R_i(t) \right)^{1-\gamma} \otimes \left[ 1 - \prod_{i=1}^n (1 - R_i(t)) \right]^\gamma \quad ; \quad \gamma \in [0, 1]$$

where  $R_i(t) = \exp\left(-\sum_{i=1}^n \lambda_i \cdot t\right)$  is the reliability of the  $i^{th}$  component.

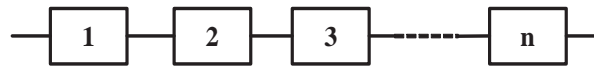

Figure 4.1: Structure of the series system

*Example :* Assume that a radio set [12, 21] consists of three independent major components: a power supply, a receiver, and an amplifier, and all must work normally to operate the radio set successfully. Let intuitionistic fuzzy failure rates of components: a power supply, a receiver, and an amplifier are in form of different types of IFNs  $\lambda_1, \lambda_2$  and  $\lambda_3$  whose values are given in Table 4.1 [12, 21]. At various mission times  $t = 5, 10$  and  $15$

Table 4.1: Input data for series system

Intuitionistic fuzzy failure rate of $i^{th}$ component of series system	Types of the intuitionistic fuzzy numbers
$\lambda_1=(0.02, 0.03, 0.04 ; 0.01, 0.03, 0.05)$	Triangular intuitionistic fuzzy number
$\lambda_2=(0.03, 0.04, 0.05, 0.06 ; 0.02, 0.04, 0.05, 0.07)$	Trapezoidal intuitionistic fuzzy number
$\lambda_3=(0.02, 0.05, 0.08, 0.12 ; 0.01, 0.04, 0.09, 0.14)$	Trapezoidal intuitionistic fuzzy number

hrs, the proposed approach has been applied for computing various  $\alpha$ - and  $\beta$ - cuts of the system reliability  $R_s(t)$ . Initially, considering  $\gamma = 0$  and hence reliability of the system has been computed at different  $\alpha$ - and  $\beta$ - cuts for different mission times. The results corresponding to this decision parameter ( $\gamma = 0$ ) is summarized in Table 4.2 along with the existing techniques results [12, 21] which shows that the proposed approach follows the same trend as that of previous methods and hence it is conservative in nature. On the other hand, the effect of the  $\gamma$  parameter on the system reliability has been analyzed by varying its values from 0 to 1 with an increment of 0.2 and their corresponding ranges of these various cuts are summarized in Table 4.3 along with the existing results.

### 4.3.2 Series-parallel system

Consider the system shown in Fig. 4.2 where the reliability of the components  $A_1, A_2, A_3$  and  $A_4$  are represented by IFNs  $R_1, R_2, R_3, R_4$  respectively whose values are given in Table 4.4 [12, 20], then the reliability of the system  $\tilde{R}_{sp}$  is

$$\begin{aligned} R_{sp} &= (R_1 \cup R_2) \cap (R_3 \cup R_4) \\ &= (R_{12} \otimes R_{34})^{1-\gamma} \otimes (1 - (1 - R_{12}) \otimes (1 - R_{34}))^\gamma \end{aligned}$$

where  $R_{12} = R_1 \cup R_2$  and  $R_{34} = R_3 \cup R_4$  be reliability of  $A_1 \cup A_2$  and  $A_3 \cup A_4$  respectively.

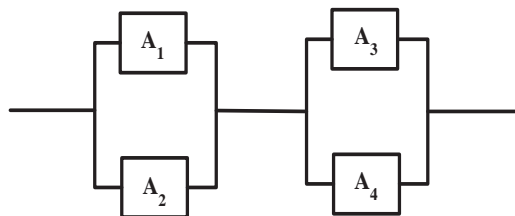

Figure 4.2: Series-parallel system



Table 4.3: Series system reliability values at different  $\gamma$

		At $t = 5$			At $t = 10$			At $t = 15$		
Membership function values		Proposed			Existing [12, 21]			Proposed		
$\gamma$	Existing [12, 21]	Proposed	Existing [12, 21]	Proposed	Existing [12, 21]	Proposed	Existing [12, 21]	Proposed		
0.0	[0.33287, 0.44932, 0.54881, 0.70468]	[0.26721, 0.39083, 0.50066, 0.68048]	[0.11080, 0.20189, 0.30119, 0.49658]	[0.06539, 0.13815, 0.22867, 0.44069]	[0.03688, 0.09071, 0.16529, 0.34993]	[0.01723, 0.05003, 0.10378, 0.27883]				
0.2	[0.41467, 0.52670, 0.61752, 0.75255]	[0.34693, 0.47109, 0.57465, 0.73487]	[0.17175, 0.27614, 0.37849, 0.55880]	[0.11024, 0.20322, 0.30567, 0.51871]	[0.07101, 0.14398, 0.23022, 0.41041]	[0.03627, 0.08818, 0.16052, 0.35882]				
0.4	[0.51659, 0.61739, 0.69483, 0.80366]	[0.45060, 0.56791, 0.65962, 0.79362]	[0.26622, 0.37769, 0.47562, 0.62882]	[0.18626, 0.29928, 0.40885, 0.61061]	[0.13671, 0.22853, 0.32066, 0.48134]	[0.07673, 0.15587, 0.24875, 0.46194]				
0.6	[0.64354, 0.72371, 0.78182, 0.85825]	[0.58555, 0.68476, 0.75721, 0.85706]	[0.41265, 0.51658, 0.59769, 0.70761]	[0.31604, 0.44159, 0.54735, 0.71890]	[0.26321, 0.36271, 0.44661, 0.56452]	[0.16401, 0.27710, 0.38671, 0.59506]				
0.8	[0.80170, 0.84833, 0.87970, 0.91654]	[0.76150, 0.82585, 0.86932, 0.92560]	[0.63964, 0.70655, 0.75108, 0.79628]	[0.54066, 0.65364, 0.73379, 0.84653]	[0.50676, 0.57569, 0.62204, 0.66208]	[0.35914, 0.49834, 0.60459, 0.76717]				
1.0	[0.99873, 0.99441, 0.98984, 0.97880]	[0.99139, 0.99633, 0.99814, 0.99962]	[0.99148, 0.96637, 0.94384, 0.89605]	[0.94009, 0.97266, 0.98570, 0.99704]	[0.97565, 0.91373, 0.86638, 0.77650]	[0.83817, 0.91830, 0.95484, 0.99023]				
Non-membership function values		Proposed			Existing [12, 21]			Proposed		
$\gamma$	Existing [12, 21]	Proposed	Existing [12, 21]	Proposed	Existing [12, 21]	Proposed				
0.0	[0.42741, 0.27253, 0.81873, 0.57694]	[0.36800, 0.20563, 0.80929, 0.53255]	[0.18268, 0.07427, 0.67032, 0.33287]	[0.12266, 0.03963, 0.64234, 0.26014]	[0.07808, 0.02024, 0.54881, 0.19204]	[0.04219, 0.00851, 0.50275, 0.12547]				
0.2	[0.50615, 0.35343, 0.84646, 0.64259]	[0.44887, 0.28074, 0.84426, 0.60382]	[0.25519, 0.12488, 0.70305, 0.40963]	[0.18456, 0.07277, 0.70170, 0.33923]	[0.12805, 0.04411, 0.57601, 0.25909]	[0.07669, 0.01989, 0.57660, 0.18748]				
0.4	[0.59939, 0.45836, 0.87513, 0.71570]	[0.54761, 0.38353, 0.88074, 0.68406]	[0.35649, 0.20999, 0.73738, 0.50410]	[0.27803, 0.13404, 0.76657, 0.44258]	[0.20999, 0.09613, 0.60457, 0.34955]	[0.13983, 0.04686, 0.66134, 0.28055]				
0.6	[0.70981, 0.59443, 0.90478, 0.79713]	[0.66821, 0.52444, 0.91880, 0.77637]	[0.49800, 0.35310, 0.77339, 0.62035]	[0.41974, 0.24852, 0.83744, 0.57784]	[0.34439, 0.20950, 0.63453, 0.47159]	[0.25651, 0.11196, 0.75858, 0.42093]				
0.8	[0.84057, 0.77091, 0.93542, 0.88782]	[0.81560, 0.71816, 0.95851, 0.88043]	[0.69568, 0.59373, 0.81115, 0.76342]	[0.63598, 0.46713, 0.91488, 0.75520]	[0.56478, 0.45656, 0.66599, 0.63624]	[0.47664, 0.27703, 0.87019, 0.63433]				
1.0	[0.99542, 0.99977, 0.96711, 0.98883]	[0.99588, 0.98561, 0.99993, 0.99851]	[0.97182, 0.99835, 0.85076, 0.93948]	[0.96969, 0.90514, 0.99950, 0.98846]	[0.92623, 0.99497, 0.69900, 0.85836]	[0.91086, 0.76224, 0.99833, 0.96313]				

Table 4.4: Input data for series-parallel system

Intuitionistic fuzzy reliability of $i^{th}$ component of the system	Type of intuitionistic fuzzy numbers
$R_1=(0.03, 0.04, 0.05 ; 0.02, 0.04, 0.07)$	Triangular intuitionistic fuzzy number
$R_2=(0.02, 0.03, 0.04, 0.06 ; 0.01, 0.03, 0.04, 0.07)$	Trapezoidal intuitionistic fuzzy number
$R_3=(0.03, 0.06, 0.08, 0.11 ; 0.02, 0.04, 0.09, 0.14)$	Trapezoidal intuitionistic fuzzy number
$R_4=(0.02, 0.04, 0.06 ; 0.01, 0.04, 0.08)$	Triangular intuitionistic fuzzy number

By representing the given data in the form of fuzzy numbers, the corresponding system reliability  $R_{sp}$  is obtained at different levels of  $\alpha$ - and  $\beta$ - cut levels of significance. The membership and non-membership functions value corresponding to system reliability are computed and summarized in Table 4.5 along with the existing technique result [12]. The variation of these computed result at different value of parameter  $\gamma$  are depicted in Fig. 4.3 along with existing approaches result. From these plotted and tabulated results, it has been observed that the proposed result has a less range of uncertainty i.e. have less range of prediction than existing approaches.

Figure 4.3: Series-Parallel system Reliability at different values of parameter  $\gamma$

Table 4.5: Series-parallel system reliability values at different  $\gamma$ 

$\gamma$	Membership function values		Non-membership function values	
	Garg [12]	Proposed	Garg [12]	Proposed
0.0	[0.00244, 0.00671, 0.00915, 0.01748]	[0.00131, 0.00379, 0.00527, 0.01064]	[0.00539, 0.00088, 0.02820, 0.00991]	[0.00300, 0.00046, 0.01811, 0.00574]
0.2	[0.00617, 0.01304, 0.01622, 0.02459]	[0.00228, 0.00625, 0.00855, 0.01666]	[0.01105, 0.00287, 0.03266, 0.01687]	[0.00499, 0.00085, 0.02761, 0.00929]
0.4	[0.01561, 0.02535, 0.02873, 0.03460]	[0.00466, 0.01160, 0.01543, 0.02829]	[0.02264, 0.00930, 0.03782, 0.02872]	[0.00944, 0.00194, 0.04485, 0.01667]
0.6	[0.03951, 0.04927, 0.05089, 0.04868]	[0.01039, 0.02330, 0.03001, 0.05138]	[0.04641, 0.03012, 0.04379, 0.04891]	[0.01937, 0.00482, 0.07731, 0.03220]
0.8	[0.09997, 0.09574, 0.09014, 0.06849]	[0.02590, 0.05224, 0.06504, 0.10314]	[0.09510, 0.09752, 0.05070, 0.08328]	[0.04440, 0.01331, 0.14593, 0.06925]
1.0	[0.25291, 0.18604, 0.15968, 0.09635]	[0.09969, 0.16850, 0.19760, 0.27349]	[0.19489, 0.31569, 0.05871, 0.14180]	[0.14895, 0.05993, 0.34638, 0.20726]

### 4.3.3 Sump pump system

This example states that a building basement equipped with a sump pump system may be flooded during heavy rainstorms if the rate of inflow water exceeds the normal pump capacity. However, a smaller rainstorm may cause a flooding in the basement if the sump pump system is not operating properly. For this, a system [12] has been considered which consists of a primary pump operated by the utility power and a back-up battery-operated pump that will be automatically activated on power failure shown in Fig. 4.4(a). The failure of the pump system will occur if both primary pump and the back-up pump fail to operate during periods of ground water inflow from a storm. However, the primary pump will fail if it breaks down or if there is a power outage while the back-up pump will fail if it malfunctions or if the battery is drained. On the other hand, if both the periods of power outage and inflow exceed the battery capacity then the battery will be drained. Thus the various components/events  $E_i, i = 1, 2, \dots, 12$  associated with the system are defined as below.

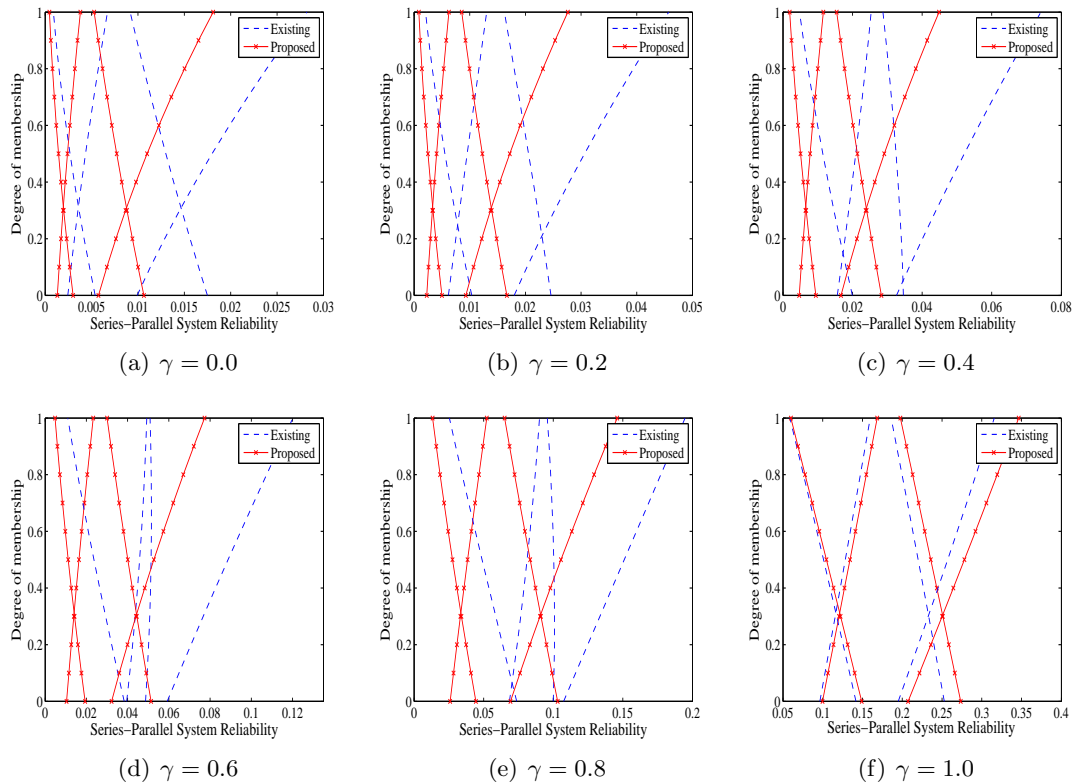
- $E_1$ : failure of occupant to take remedial action.
- $E_2$ : period of power outage exceeds battery capacity.
- $E_3$ : period of inflow exceeds the battery capacity.
- $E_4$ : battery drained.
- $E_5$ : back-up pump malfunctions.
- $E_6$ : back-up pump fails.
- $E_7$ : power outage.
- $E_8$ : primary pump malfunctions.
- $E_9$ : primary pump fails.

- $E_{10}$ : inflow to basement sump.  
 $E_{11}$ : failure of pump system.  
 $E_{12}$ : rate of inflow exceeds pump capacity.

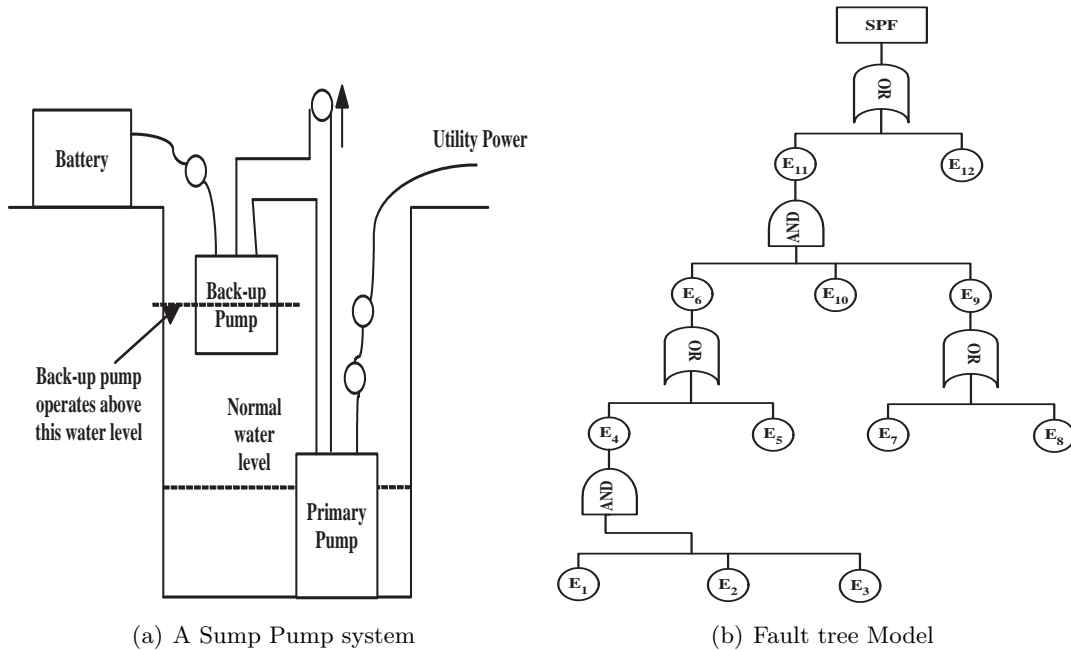

Figure 4.4: Systematic diagram and Fault tree model of a sump pump system

The equivalent systematic diagram of the system and their corresponding fault tree model has been given in Fig. 4.4(a) and 4.4(b) respectively, where SPF represents the system top failure events. The data related to various events of the system are collected from the historical records/logbooks/sheets etc and are integrated with the help of the plant personal. But due to various practical reasons, the collected data obtained from various resources possess uncertainties, impreciseness or vagueness. So to handle them, the obtained (crisp) data are fuzzified into trapezoidal fuzzy numbers with some known spread on both side of the data as suggested by the system analyst/decision makers and are given in Table 4.6 [12], where  $R_i$  represents the reliability of  $i^{th}$  events in the form of intuitionistic fuzzy numbers.

Based on the fault tree model, the reliability of the main events of the system is written as

$$R_4 = R_1 \cap R_2 \cap R_3 \quad ; \quad R_6 = R_4 \cup R_5 \quad ; \quad R_9 = R_7 \cup R_8 \quad ; \quad R_{11} = R_6 \cap R_9 \cap R_{10}$$

Table 4.6: Input data for the main component of the pump

Reliability of the main components of the pump in IFNs	
$R_1 = (0.02, 0.05, 0.08, 0.13; 0.01, 0.03, 0.09, 0.14)$	$R_2 = (0.20, 0.33, 0.36, 0.41; 0.09, 0.31, 0.37, 0.42)$
$R_3 = (0.04, 0.07, 0.10, 0.14; 0.03, 0.05, 0.11, 0.15)$	$R_5 = (0.05, 0.08, 0.11, 0.16; 0.04, 0.06, 0.12, 0.17)$
$R_7 = (0.10, 0.13, 0.16, 0.21; 0.09, 0.11, 0.17, 0.22)$	$R_8 = (0.06, 0.09, 0.12, 0.17; 0.05, 0.07, 0.13, 0.18)$
$R_{10} = (0.10, 0.12, 0.15, 0.17; 0.08, 0.11, 0.16, 0.19)$	$R_{12} = (0.05, 0.08, 0.11, 0.14; 0.03, 0.07, 0.12, 0.16)$

while the resultant fuzzy reliability of basement flooding system is computed as

$$R_s = R_{11} \cup R_{12}$$

By representing the given data, the corresponding system reliability  $R_s$  is obtained at different levels of  $\alpha$ - and  $\beta$ - cut levels of significance. The ranges of membership and

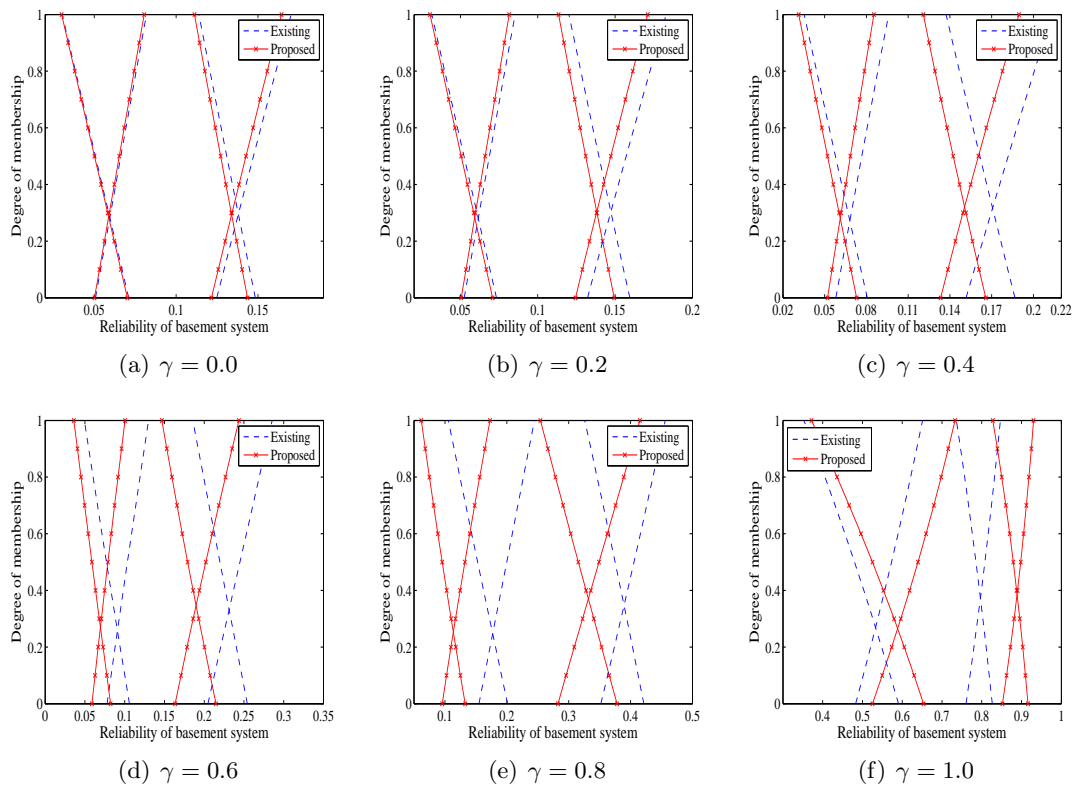
Figure 4.5: Reliability of sump-pump system at different values of parameter  $\gamma$ 

non-membership functions value corresponding to system reliability are computed and summarized in Table 4.7 while their variations with degree of membership are plotted in

Fig. 4.5 along with existing approaches result. Based on these results, a system analyst may take appropriate action for better managerial decision-making and estimate success interval more flexible than previous methods.

Table 4.7: Reliability of basement flooding system at different values of parameter  $\gamma$

$\gamma$	Membership function values		Non-membership function values	
	Garg [12]	Proposed	Garg [12]	Proposed
0.0	[0.05073, 0.08186, 0.11391, 0.14836]	[0.05013, 0.08047, 0.11117, 0.14361]	[0.07106, 0.03042, 0.17019, 0.12482]	[0.07021, 0.03007, 0.16433, 0.12151]
0.2	[0.05239, 0.08537, 0.12018, 0.15953]	[0.05050, 0.08155, 0.11348, 0.14945]	[0.07331, 0.03148, 0.18303, 0.13215]	[0.07077, 0.03030, 0.17111, 0.12436]
0.4	[0.05798, 0.09599, 0.13722, 0.18668]	[0.05202, 0.08538, 0.12086, 0.16577]	[0.08060, 0.03529, 0.21321, 0.15153]	[0.07293, 0.03131, 0.18960, 0.13323]
0.6	[0.07785, 0.13002, 0.18565, 0.25423]	[0.05880, 0.10043, 0.14678, 0.21490]	[0.10598, 0.04934, 0.28541, 0.20464]	[0.08229, 0.03604, 0.24368, 0.16334]
0.8	[0.15483, 0.24465, 0.32593, 0.42142]	[0.09549, 0.17278, 0.25429, 0.37809]	[0.20114, 0.10532, 0.45605, 0.35194]	[0.13263, 0.06162, 0.41516, 0.28260]
1.0	[0.48281, 0.65093, 0.73626, 0.82644]	[0.52507, 0.73271, 0.82771, 0.91640]	[0.59053, 0.35279, 0.84685, 0.76032]	[0.65354, 0.37188, 0.93027, 0.85200]

## 4.4 Conclusion

In this chapter, a systematic procedure for computing the reliability of the series, series-parallel and mixed configuration structure have been presented. For it, the proposed approach uses “*compensatory and*” operator to provide the range of the system data at different values of parameter  $\gamma$  and trapezoidal/triangular fuzzy number has been utilized for representing the possibilities of system components’. The major advantages of the proposed approach is that it incorporates not only fuzzy factors but also the designer’s experience and knowledge in the decision-making process. Based on these compensatory operator for different t-norm operations, reliability analysis of some configuration systems have been assessed and compare with their existing norm operations at different values of  $\gamma$ . A system analyst may take appropriate action for better managerial decision-making and estimate success interval more flexible than previous methods.

# Bibliography

- [1] Attanassov, K. T.: 1986, Intuitionistic fuzzy sets, *Fuzzy Sets and Systems* **20**, 87 – 96.
- [2] Birolini, A.: 2007, *Reliability Engineering: Theory and Practice*, 5 edn, Springer, New York, NY.
- [3] Cai, K. Y., Wen, C. Y. and Zhang, M. L.: 1993, Fuzzy states as a basis for a theory of fuzzy reliability, *Microelectron Reliability* **33**, 2253–2263.
- [4] Chen, S. M.: 1994, Fuzzy system reliability analysis using fuzzy number arithmetic operations, *Fuzzy Sets and Systems* **64**(1), 31–38.
- [5] Cheng, C. H. and Mon, D. L.: 1993, Fuzzy system reliability analysis by interval of confidence, *Fuzzy Sets and Systems* **56**(1), 29–35.
- [6] Ebeling, C.: 2001, *An Introduction to Reliability and Maintainability Engineering*, Tata McGraw-Hill Company Ltd., New York.
- [7] Garg, H.: 2013, Reliability analysis of repairable systems using Petri nets and Vague Lambda-Tau methodology, *ISA Transactions* **52**(1), 6 – 18.
- [8] Garg, H.: 2014a, Performance and behavior analysis of repairable industrial systems using vague lambda-tau methodology, *Applied Soft Computing* **22**, 323 – 338.
- [9] Garg, H.: 2014b, Reliability, availability and maintainability analysis of industrial systems using pso and fuzzy methodology, *MAPAN - Journal of Metrology Society of India* **29**(2), 115 – 129.

- [10] Garg, H.: 2015a, An approach for analyzing the reliability of industrial system using fuzzy kolmogorov's differential equations, *The Arabian Journal for Science and Engineering* **40**(3), 975 – 987.
- [11] Garg, H.: 2015b, *A Hybrid GA - GSA Algorithm for Optimizing the Performance of an Industrial System by Utilizing Uncertain Data*, Handbook of Research on Artificial Intelligence Techniques and Algorithms, IGI Global.
- [12] Garg, H.: 2016, A novel approach for analyzing the reliability of series-parallel system using credibility theory and different types of intuitionistic fuzzy numbers, *Journal of the Brazilian Society of Mechanical Sciences and Engineering* **38**(3), 1021 – 1035.  
**URL:** [10.1007/s40430-014-0284-2](http://dx.doi.org/10.1007/s40430-014-0284-2)
- [13] Garg, H. and Rani, M.: 2013, An approach for reliability analysis of industrial systems using PSO and IFS technique, *ISA Transactions* **52**(6), 701 – 710.  
**URL:** <http://dx.doi.org/10/1016/j.isatra.2013.06.010>
- [14] Garg, H., Rani, M. and Sharma, S. P.: 2013, Reliability analysis of the engineering systems using intuitionistic fuzzy set theory, *Journal of Quality and Reliability Engineering* **2013**, Article ID 943972, 10 pages.
- [15] Garg, H., Rani, M. and Sharma, S. P.: 2014, An approach for analyzing the reliability of industrial systems using soft computing based technique, *Expert systems with Applications* **41**(2), 489 – 501.
- [16] Garg, H., Rani, M., Sharma, S. P. and Vishwakarma, Y.: 2014, Intuitionistic fuzzy optimization technique for solving multi-objective reliability optimization problems in interval environment, *Expert Systems with Applications* **41**, 3157 – 3167.
- [17] Garg, H. and Sharma, S. P.: 2012, Stochastic behavior analysis of industrial systems utilizing uncertain data, *ISA Transactions* **51**(6), 752 – 762.
- [18] Klir, G. J. and Yuan, B.: 2005, *Fuzzy Sets and Fuzzy Logic: Theory and Applications*, Prentice Hall of India Private Limited, New Delhi.

- [19] Knezevic, J. and Odoom, E. R.: 2001, Reliability modeling of repairable systems using Petri nets and Fuzzy Lambda-Tau Methodology, *Reliability Engineering and System Safety* **73**(1), 1–17.
- [20] Kumar, M. and Yadav, S. P.: 2011, Fuzzy system reliability analysis using different types of intuitionistic fuzzy numbers, *11th International Conference on Hybrid Intelligent Systems (HIS)*, pp. 247 –252.
- [21] Kumar, M. and Yadav, S. P.: 2012, A novel approach for analyzing fuzzy system reliability using different types of intuitionistic fuzzy failure rates of components, *ISA Transactions* **51**(2), 288 – 297.
- [22] Mon, D. L. and Cheng, C. H.: 1994, Fuzzy system reliability analysis for components with different membership functions, *Fuzzy Sets and Systems* **64**(2), 145–157.
- [23] Singer, D.: 1990, A fuzzy set approach to fault tree and reliability analysis, *Fuzzy Sets and Systems* **34**(2), 145–155.
- [24] Zadeh, L. A.: 1965, Fuzzy sets, *Information and Control* **8**, 338–353.