

Procreation of Energy Efficient Hierarchical Routing Protocols for Wireless Sensor Networks

A Thesis

submitted in partial fulfillment of the requirements for the award of degree of

Doctor of Philosophy

by

Deepak Mehta

Registration No. 951311001

under the guidance of

Dr. Sharad Saxena

(Associate Professor)



THAPAR INSTITUTE
OF ENGINEERING & TECHNOLOGY
(Deemed to be University)

Computer Science and Engineering Department
Thapar Institute of Engineering & Technology
Patiala-147004, Punjab, INDIA
October-2021

Certificate

I hereby certify that the work being presented in this thesis titled “**Procreation of Energy Efficient Hierarchical Routing Protocols for Wireless Sensor Networks**”, in partial fulfilment of the requirement for the award of degree of “Doctor of Philosophy” submitted in Computer Science and Engineering Department of Thapar Institute of Engineering and Technology, Patiala, is an authentic record of my own work carried out under the supervision of Dr. Sharad Saxena. The work has referred research work of others which are duly listed in the reference section.

The matter presented in this thesis has not been submitted for the award of any other degree or to any other university.



Deepak Mehta
(Registration No: 951311001)

This is to certify that the above statement made by the candidate is correct and true to the best of knowledge.



(Dr. Sharad Saxena)
Associate Professor
Computer Science and Engineering Department
Thapar Institute of Engineering and Technology, Patiala

Acknowledgement

I would like to express my sincere appreciation to my supervisor, **Dr. Sharad Saxena**, Associate Professor, CSED for being pillar of support and encouragement throughout my research work. His experience, tenderness, strengths, and wilfulness, have taught me valuable lessons of life, which are going to be of immense help in taking decision for moving forward.

My sincere thanks to **Prof. Prakash Gopalan**, Director, **Prof. Rafat Siddique**, Dean of Research/Scientific Projects, **Prof. R. S. Kaler**, Dean of Faculty Affair, **Prof. S. S. Bhatia**, Dean of Students Affair and **Prof. Maninder Singh**, Head, Computer Science and Engineering Department, Thapar Institute of Engineering and Technology, Patiala, Punjab, India; for providing me the necessary administrative assistance in completion of this work. I am also thankful to my Ph.D. committee members **Dr. Singara Singh**, **Dr. Rinkle Rani**, and **Dr. Urvinder Singh**, Thapar Institute of Engineering and Technology, Patiala for their constructive comments and regularly ensuring the progress of my research work. Lastly, I am thankful to all the faculty and staff members of the department for their kind support.

I offer my deepest gratitude to my loving parents late **Sh. Jagdish Raj Mehta Ji** and late **Smt. Sudesh Kumari Mehta Ji**, whose love and affection and blessings were a constant source of inspiration in taking my vision to reality. I also acknowledge the cooperation and encouragement extended to me by my wife Mrs. **Neha Mehta** and my children **Vedha Mehta** and **Arav Mehta** and all of **my family member and friends** for bringing enthusiasm and vigour during tough times. I would also like to thank my maternal uncle **Dr. N. K. Mehta**, who ignited the flame of knowledge to pursue the PhD and gave valuable guidance all through PhD.

The chain of gratitude would be definitely incomplete without thanking the **Almighty**, the prime mover, for inspiring and guiding me to complete this task successfully.

Patiala
October, 2021

(Deepak Mehta)

Abstract

Wireless Sensors Network (WSNs) is a self-configured and infrastructure-less network. In the past few decades, it has been explored by many researchers for energy-efficient communication. WSNs are utilized in several real-life applications such as monitoring environmental conditions, health, security surveillance, target tracking, etc. Typically, a WSN is a collection of tiny sensor nodes powered by diminutive power sources. These sensor nodes sense phenomenal data continuously and report it to the base station using single or multi-hop communication. Hence, the network lifetime decreases continuously as the battery drains quickly while data sensing, its' processing and remote transmission. Usually, these wireless nodes are deployed in potentially harsh physical conditions, and are not feasible to change the batteries or even replenish them. Researchers have suggested various approaches to reduce the energy consumption in WSNs, such as radio optimization, reduction in data to be transmitted, sensor sleep/awake mechanism, energy harvesting, wireless charging, and energy-efficient routing. Transmission of data is supposed to be the primary source of energy depletion in WSN. Thus, energy-efficient routing and routing protocol design play an essential role in enhancing the WSN's network lifetime. The energy consumption rate of traditional WSN routing protocol is high and possesses relatively small network lifetime. They suffer from hotspot energy-hole related problems. Therefore, various types of routing protocols, including location-aware, data-centric and hierarchical, have been proposed.

Location-aware protocols take benefit of location awareness of sensor nodes. Awareness of Geographic location may help estimate energy consumption based on the calculated distance among sensor nodes. Moreover, by using location information of sensor nodes, enquiry for information may be communicated to the specific area, and thus the number of transmissions can be reduced significantly. Here, the emplacement of geographical localization devices and their credibility can be significant defiance. Moreover, the sensors' energy consumption is sheer proportional to the distance from the target node to which data is to be communicated. It implies that, with the increase in the data transmission distance, the energy consumption increases exponentially.

Data-centric protocols perform data fusion to remove redundancy and transmission. These protocols take advantage of attribute-cantered naming conventions rather than addresses. The sink

node remits the desired query to particularly identified areas and expects a response from distributed sensor nodes in that area. The major limitation of data-centric routing protocols is its' scalability. It is due to the involvement of volumetric sensor nodes in the WSN.

Hierarchical or clustering-based routing protocols divide the WSN into clusters to achieve energy-efficient communication. Each cluster has a Cluster Head (CH) and is amenable to data collection, aggregation, and forwarding it to the next CH or the BS in single/multiple hops. The challenges with hierarchical routing protocols lie in the appropriate division of the network into clusters, suitable CH nomination, and data communication in an energy-preserving way. The hybrid optimization-based CH election primarily depends on some key parameters such as energy, distance, and delay. Here the parameters like connectivity and coverage range have given less importance. Another aspect of such protocols is selecting an optimal path from the sensor node to the sink node. The leading cause of such a problem is the existence of multiple multi-hop paths.

The research work in this dissertation presents three protocols for CH selection and energy optimization. The *two* protocols are nature inspired and are energy efficient protocols namely FMCB-ER and MCH-EOR and *third* one is an improvement to the pre-existing protocol called Node-Rank-LEACH protocol and is known as LBNR-LEACH. These protocols enable effective CH selection and energy efficient path selection for communication. The FMCB-ER (Fuzzy Multi-Criteria Clustering and Bio-inspired Energy-efficient Routing) is a hierarchical-WSN protocol, MCH-EOR is a "Multi-Objective Cluster Head-based Energy-aware Optimized Routing" protocol, and LBNR-LEACH considers the network load into consideration along with the link quality to select best CH.

FMCB-ER is structured on clustering using a grid approach. A grid has been used to divide the network into robust and distributed clusters for efficient data delivery. The F-AHP (Fuzzy-Analytic-Hierarchy-Process) and TOPSIS (Technique for Order Preference by Similarity to an Ideal Solution) methods are used to select an optimum CH based on three criteria, namely energy status, node position, and impact on QoS and their six sub-criteria. Each criterion is assigned some weights using AHP, and TOPSIS ranks the CHs using Euclidean normalized decision matrices. Euclidean normalization prevents any parameter from growing boundlessly and thus keeps balance among the parameters for CH selection. After nominating a CH, the EPO (Emperor Penguin Optimization) algorithm has been used to detect optimal path for data delivery. EPO enhances

multi-hop routing efficiency and minimizes energy utilization during data transmission, even on longer paths.

The MCH-EOR is a multi-objective and swarm-based optimization technique for hierarchical WSN. It uses an unequal clustering approach to divide the network in a distributed manner. Here, the cluster size near BS is relatively small, and the intra-cluster communication is less in the clusters near BS, thus reduces overloading on nodes near BS. It eliminates the hotspot problem. The node clusters have been created using Haversine distance that reduces the dimensionality of message transmission and preserves energy. After cluster formation, CH is selected for each cluster using a probabilistic approach and a practical fitness function. The fitness function is a weighted sum approach that has been developed, keeping multiple objectives into consideration. After selecting the CH, SailFish Optimizer (SFO) is applied to find an optimal path to BS/sink node for energy-efficient transmission. The three parameters namely energy, throughput and link quality are considered to prevent sensor nodes' failure and traffic control. Instead of each sensor node's energy, the energy of CH in the path is estimated, leading to lesser energy consumption in estimation. The algorithm periodically monitors the path before starting data communication in all iterations. If any node with less than expected energy is found, it can be removed from the path, and a different path is then selected. It eliminates the problem of network holes and makes the network more robust.

The LBNR-LEACH approach consider network load for candidate CHs and is estimated based on number of link, link priority and energy consumption in each round. The algorithm computes the node rank and waits for significant time to estimate the network load on available CH. After that the optimum cluster head is selected.

All the proposed algorithms are compared to the existing protocols in terms of energy consumption and various Quality of Service (QoS) parameters like throughput, network lifetime, number of node alive and packet delivery ratio. The results obtained from different simulations indicate that the proposed protocols perform better than the compared protocols in terms of energy efficiency and other QoS parameters.

Table of Contents

Certificate	ii
Acknowledgement	iii
Abstract	iv
List of Figures	x
List of Tables	xii
List of Algorithms	xiii
List of Symbols	xiv
Abbreviations	xvi
Chapter 1 Introduction	1
1.1. Wireless Sensor Networks	1
1.2. Architecture of Wireless Sensor Network	3
1.3. Types of Wireless Sensor Networks	5
1.4. Applications of WSN	7
1.5. Unique Characteristics of WSNs	11
1.6. WSN Challenges	12
1.7. Hierarchical Wireless Sensor Networks	13
1.7.1. Communication Methodology	14
1.7.2. Factors Affecting Routing in HWSN	15
1.7.3. Routing Challenges in HWSN	16
1.7.4. HWSN Creation Strategies	17
1.7.5. Routing Methods in HWSN	18
1.8. Types of Routing Protocol in WSN	19
1.8.1. Routing Based on Path Establishment	19
1.8.2. Routing Based on Network Architecture	20
1.8.3. Routing Based on Working of Protocols	20
1.9 Thesis Organization	21
Chapter 2 Literature Review	25
2.1. Routing Protocols in WSN	25
2.1.1 WSN Routing Challenges	25
2.1.2 WSN Routing Techniques	25
2.2. Mechanisms to Enhance WSN Lifespan	26
2.2.1 Optimization of Radio Components	27
2.2.2 Data Reduction	28
2.2.3 Sleep/Awake Mechanisms	29
2.2.4 Energy-Efficient Routing	30
2.2.5 Charging Solution	31
2.3. Classification of WSN Routing Protocols	32
2.3.1 Data Centric Routing Protocols	33
2.3.2 Geographical Routing Protocols	36
2.3.3 Network Flow and QoS Aware Routing Protocols	40

2.3.4 Hierarchical Routing Protocols	42
2.4. Optimization-based Routing Protocols for WSNs	58
2.4.1 Fuzzy Logic Based Routing Protocols	58
2.4.2 Neural Networks-Based Routing Protocols	58
2.4.3 Metaheuristics-Based Routing Protocols	60
2.5. Problem Formulation and Research Gaps Identified	74
2.6. Research Objectives	76
Chapter 3: Research Methodology	77
3.1 Problem Description	77
3.2 Requirement Specification	78
3.2.1 Software Requirements	78
3.2.2 Hardware Requirements	79
3.3 Experimental Setup	79
3.4 Comparative Statement	83
3.5 Thesis Contributions	84
Chapter 4 Fuzzy Multi-Criteria Clustering and Bio-Inspired Energy-Efficient Routing (FMCB-ER)	85
4.1 FMCB-ER Protocol Description	85
4.1.1 Network Model	86
4.1.2 Radio Energy Model	87
4.1.3 Grid Cluster Creation	87
4.1.4 Cluster Head Selection	89
4.2 Optimal Path Finding with EPO	93
4.2.1 Problem Formation and Fitness Function Estimation	93
4.2.2 EPO Based Routing Process	94
4.2.3 Random Generation of Neighbors of Cluster Heads	94
4.2.4 Estimation of Energy among CH Neighbors	94
4.2.5 Distance Estimation among CH Neighbors	95
4.2.6 Relocating the Mover	96
4.2.7 Steps Involved in EPO Based Routing	96
4.3 FMCB-ER Performance Evaluation and Result Analysis	98
4.3.1 Simulation Parameters	98
4.3.2 Simulation Results	98
4.4 Summary	108

Chapter 5 Multi-objective Based Cluster Head Selection and Energy Optimized Routing (MCH-EOR)	109
5.1 MCH-EOR Protocol Description	109
5.1.1 Network Setup	110
5.1.2 Energy Model	110
5.2 Cluster Formation and Multi-Objective-Based CH Selection	112
5.2.1 Network Area Division	112
5.2.2 Clusters Creation	113
5.2.3 Cluster Head Selection	114
5.3 Path Optimization through Sailfish Optimizer Algorithm	117
5.3.1 Attack-Alternation Strategy	117
5.3.2 Hunting and Catching the Prey	118
5.4 Data Forwarding to BS	118
5.4.1 Initialization	118
5.4.2 Path Selection Strategy	120
5.4.3 Data Communication and Path Alteration	120
5.5 MCH-EOR Performance Evaluation and Results Analysis	123
5.5.1 Simulation Parameters	123
5.5.2 Simulation Results	123
5.6 Summary	132
Chapter 6 LBNR-LEACH: An Enhanced Energy-Efficient Algorithm for Cluster Head Selection in WSN	135
6.1 LBNR-LEACH Description	135
6.1.1 Background: Node-Rank LEACH Algorithm	136
6.1.2 LBNR-LEACH Protocol Assumptions	138
6.1.3 Radio Model for LBNR-LEACH	139
6.2 LBNR-LEACH Algorithm	140
6.2.1 Setup Phase	140
6.2.2 Steady State Phase	144
6.3 LBNR LEACH Performance Evaluations	145
6.3.1 Throughput	145
6.3.2 Mean End-to-End Delay	147
6.3.3 Packet Transfer Ratio	148
6.3.4 Average Energy Ratio (AER)	149
6.3.5 Number of Alive Nodes	150
6.4 Summary	151
Chapter 7 Conclusions and Future Scope	153
7.1 Conclusion	153
7.2 Future Scope	155
Bibliography	157
List of Publications	176

List of Figures

Fig. 1.1	Architecture of Sensor Node	2
Fig. 1.2	Block diagram for functionality of Wireless Sensor node.....	3
Fig. 1.3	Wireless Sensor Network basic architecture.....	4
Fig. 1.4	Flat architecture of a Wireless Sensor Network.....	4
Fig. 1.5	Single hop clustering architecture of a Wireless Sensor Network...4	
Fig. 1.6	Multi hop clustering architecture of a Wireless Sensor Network....5	
Fig. 1.8	Types of Wireless Sensor Networks.....	6
Fig. 1.9	Applications of Wireless Sensor Networks.....	7
Fig. 1.10	Environment monitoring using WSNs.....	8
Fig. 1.11	Health care monitoring using WSNs.....	9
Fig. 1.12	WSN Applications in Forest Monitoring.....	10
Fig. 1.13	Agricultural applications of WSNs.....	11
Fig. 1.14	Single Hop communication.....	15
Fig. 1.15	Multi-hop communication.....	15
Fig. 1.16	Cluster based HWSN.....	18
Fig. 1.17	Types of routing protocols in WSNs.....	19
Fig. 2.1	WSN Routing Methods.....	26
Fig. 2.2	Types of energy saving mechanisms.....	27
Fig. 2.3	Example of network coding.....	29
Fig. 2.4	Classification of routing protocols in Wireless Sensor Networks...34	
Fig. 2.5	Relay region for transmit-relay node pair (i, r) in MECN.....	37
Fig. 2.6	Example of virtual grid in GAF.....	38
Fig. 2.7	State transitions in Geographic Adaptive Fidelity routing.....	39
Fig. 2.8	Queuing model for a specific sensor node.....	41
Fig. 2.9	Routing components of SPEED.....	42
Fig. 2.10	Comparison of flat and clustered WSNs.....	43
Fig. 2.11	Chain based hierarchical routing.....	44
Fig. 2.12	Chain formation for PEGASIS.....	45
Fig. 2.13	Data gathering in a chain based binary scheme.....	46
Fig. 2.14	Tree based Hierarchical routing protocols.....	48
Fig. 2.15	Hierarchical Grid-based routing.....	49
Fig. 2.16	Hierarchical Area-based routing.....	52
Fig. 2.17	Hierarchical routing in TEEN.....	57
Fig. 2.18	Optimization Techniques in WSN.....	60
Fig. 2.19	Categories of ACO-based routing techniques in WSN.....	64
Fig. 3.1	Initial node deployment FMCB-ER.....	80
Fig. 3.2	Initial Node Deployment with Sink FMCB-ER.....	80
Fig. 3.3	Cluster Head selection FMCB-ER.....	81
Fig. 3.4	Routing in WSN MCH-EOR.....	82
Fig. 3.5	Network setup for LBNR-LEACH.....	83
Fig. 4.1	Flow Diagram of FMCB-ER protocol.....	86

Fig. 4.2	Deployment structure of proposed network model.....	86
Fig. 4.3	Grid with grid ID and lane.....	88
Fig. 4.4	Decision making criterion.....	89
Fig 4.5	Energy consumption comparison.....	99
Fig 4.6	Comparison of Throughput.....	100
Fig 4.7	Comparison of End-to-End Delay.....	101
Fig 4.8	Comparison of Latency.....	102
Fig 4.9	Comparison of network lifetime.....	104
Fig 4.10	Comparison of Jitter.....	104
Fig 4.11	Comparison of Packet delivery ratio.....	105
Fig 4.12	Comparison of Number of alive nodes.....	106
Fig 4.13	Comparison of Number of dead sensor nodes.....	107
Fig. 5.1	Steps of MCH-EOR.....	111
Fig. 5.2	Network structure of the proposed approach.....	111
Fig. 5.3	Process of distance estimation with Haversine distance.....	113
Fig. 5.4	CH selection based on different objectives.....	113
Fig. 5.5	a) Path selection, b) Path alteration, and forwarding data to BS with SFO.....	121
Fig. 5.6	Network lifetime.....	124
Fig. 5.7	Comparison of alive nodes of MCH-EOR with compared routing techniques.....	126
Fig. 5.8	Comparison of dead nodes.....	127
Fig. 5.9	Comparison of consumed energy.....	128
Fig. 5.10	Comparison of throughput.....	130
Fig. 5.11	Comparison of packet delivery ratio.....	131
Fig. 5.12	Comparison of Cost Function Performance.....	132
Fig. 6.1	Cluster Formation using LEACH protocol.....	136
Fig. 6.2	Radio Model.....	139
Fig. 6.3	Link Importance.....	141
Fig. 6.4	LBNR-LEACH Algorithm.....	142
Fig. 6.5	Throughput Vs Count of nodes.....	146
Fig. 6.6	Average Delay vs Number of Nodes.....	147
Fig. 6.7	PDF vs Number of Nodes.....	148
Fig. 6.8	Average Energy Ratio.....	150
Fig. 6.9	Number of Alive Nodes.....	151

List of Tables

Table 2.1	Summary of Literature review.....	69
Table 3.1	Simulation Parameters for FMCB-ER.....	79
Table 3.2	Simulation Parameters for MCH-EOR.....	81
Table 3.3	LBNR-LEACH Simulation Parameters.....	82
Table 4.1	Rank and fuzzy membership values.....	91
Table 4.2	Simulation parameters.....	98
Table 4.3	Energy Consumption (mJ).....	99
Table 4.4	Throughput (%).....	100
Table 4.5	End to end delay (ms).....	101
Table 4.6	Latency (ms).....	102
Table 4.7	Network lifetime (number of rounds).....	103
Table 4.8	Jitter (ms).....	105
Table 4.9	Packet Delivery Ratio.....	106
Table 4.10	Number of Alive Nodes.....	107
Table 4.11	Number of Dead Nodes.....	108
Table 5.1	Parameters and values utilized during simulation.....	123
Table 5.2	Network lifetime (in rounds).....	125
Table 5.3	Number of alive Sensor Nodes.....	126
Table 5.4	Number of dead Sensor Nodes.....	128
Table 5.5	Energy consumption.....	129
Table 5.6	Throughput (%0.....	130
Table 5.7	Packet Delivery Ratio.....	131
Table 5.8	Features Comparison of MCH-EOR with other compared approaches..	132
Table 6.1	Network Simulations parameters.....	145
Table 6.2	Throughput.....	146
Table 6.3	Average Delay.....	148
Table 6.4	Packet Transfer Ratio.....	149
Table 6.5	Average Energy.....	150
Table 6.6	Alive Nodes.....	151

List of Algorithms

Algorithm 4.1	Identifying level and grid of node.....	88
Algorithm 4.2	Proposed EPO based routing.....	97
Algorithm 5.1	Multi-objective-based cluster head selection algorithm.....	116
Algorithm 5.2	SFO based routing algorithm.....	122
Algorithm 5.3	Overall algorithm of the proposed routing.....	122
Algorithm 6.1	Node Ranked LEACH algorithm.....	137
Algorithm 6.2	LBNR-LEACH algorithm.....	144

List of Symbols

$dis(a, b)$	Distance between a and b
$En(a, b)$	Energy to transmit from a to b
α	Path loss
C_{n1}, C_{n2}	Constant values
$tuple(a, b)$	Grid ID
h_{cl}	Grid height
En_{CH}	Energy of cluster head
$dis(CH_i, CM_j)$	Distance between i and j cluster head
CM	Cluster member
dis_{Avg}	Distance between communicating node and neighboring node
dis_0	Dissemination radius of the sensor nodes
$ReNum_{max}$	Maximum restart number
$ReNum_{min}$	Minimum restart number
C_r	Multi criteria
E_{ij}	Normalised decision matrix
WI_i	Weighted normalised matrix
DM	Decision matrix
f_{ij}	Euclidean matrix
d_{ij}	Distance between i and j
u^+ and u^-	Correlated criteria with positive and negative impact
AIS^+ and AIS^-	Distance from every alternative node
CC_i^*	Comparative proximity
RE_f	Residual energy factor
ObjFun	Objective function
D_f	Distance factor
σ	Gradient
V	Vector
$F()$	Analytical function
Max_{ite}	Highest iteration
\vec{B}_{OS}	Best optimal solution
P_{CH}	Cluster head position
\vec{K} and \vec{L}	Speed vectors
Mov_p	Moving parameter
$Nt_{grid}(Acc)$	Network grid accuracy
$Rm()$	Random value
$\vec{P}_{CH}(x + 1)$	Updated position
$CH_E(n)$	Energy used by cluster head
CM_{ij}	Cluster matrix
L_i and N_j	Number of sensor nodes
$E_{Res}(n)$	Residual energy
P_s	Energy consumption
P_{ec}	Power
P_{frs}	Free space power
P_{mpf}	Muti path fading power

P_{Eagg}	Aggregate power
W_i	Weight
H_i	Height
N	Number of nodes
N_{CL_1}	Nearest layer to base station
$Diff_{Nodes}$	Haversine distance
Loc_{N_i} and Loc_{N_j}	Location of nodes
$d(n, i)$	Distance between node n and i
N_T	Total number of sensor nodes
C_{Com}	Communication cost
E_{Res}	Residual energy
N_{Cov}	Network coverage
$X_{new_SF}^i$	Sailfish attack position
X_{new_S}	Sardine position
CH_{pos}	Cluster head position
Th	Throughput
$Link_Q$	Quality of link
Loc_{BS}	Location of base station
P_{best}	Best path
CH_i^{elite}	Position of new cluster
λ_i	Co-efficient of ith iteration
P_{alt}	Path alteration
$E_{need}(CH_i, CH_j)$	Energy needed to transmit from i to j cluster head
N_A^i	Number of alive nodes
$E_{Res}(n)$	Residual energy of nth node
N_D^i	Number of dead nodes
$T(n)$	Threshold value
β	Mean value of first order differences
FF	Fitness function
OF	Objective function
Avg_{Delay}	Average delay

List of Abbreviations

CH	Cluster Head
SN	Sensor Node
MCH-EOR	Multi Criteria Cluster Head – Energy Optimized Routing
FMCB-ER	Fuzzy Multi criteria based Energy optimized Routing
AHP	Analytical Hierarchical Process
TOPSIS	Technique for Order of Preference by Similarity to Ideal Solution
EPO	Emperor Penguin Optimizer
ACO	Ant Colony Optimization
SFO	Sailfish Optimizer
PSO	Particle Swarm Optimization
LEACH	Low Energy Adaptive Clustering Hierarchy
BS	Base Station
LBNR	Load Balanced Node Rank
NR	Node Rank
QoS	Quality of Service
WSN	Wireless Sensor Network
AER	Average Energy Ratio
PDF	Packet Delivery Fraction
NS2	Network Simulator 2
TDMA	Time Division Multiple Access
DD	Directed Diffusion
GPS	Global Positioning System
MECN	Minimum Energy Communication Network
SMECN	Small Minimum Energy Communication Network
GAF	Geographic Adaptive Fidelity
HRP	Hierarchical Routing Protocol
PEGASIS	Power-Efficient Gathering in Sensor Information Systems
CHIRON	Chain-based Hierarchical Routing Protocol
CL	Cluster Leader
CM	Cluster Member
COARP	Cuckoo Optimization Algorithm based Routing Protocol
RFCM-ACO	Rough Fuzzy c-means and Ant Colony Optimization
IEPSO	Improved Evolutionary Particle Swarm Optimization
GASONEC	Genetic Algorithm Based, Self-Organizing Network Clustering
GASONEC	Genetic Algorithm Based, Self-Organizing Network Clustering (GASONEC)
GWOEECR	Grey Wolf Optimization Energy Efficient Cluster Routing GWOEECR
TPSO-CR	Two tier Particle Swarm Optimization for Clustering and Routing
SMEER	Secure Multi-tier Energy Efficient Routing
MST	Minimum Spanning Tree
ETR	Enhanced tree routing
PEDAP	Power-efficient data gathering and aggregation protocol
CR	Cognitive radio
TPC	Transmission Power Control

RFID	Radio Frequency Identification
EEMRP	Energy-Efficient Multipath Routing Protocol
SPIN	Sensor protocols for information via negotiation
CADR	Constrained Anisotropic Diffusion Routing
ACQUIRE	Active QUery forwarding InsensoR nEtworks
EBCRP	Energy-balanced chain-cluster routing protocol
EADAT	Energy-aware data aggregation tree
GAF	<i>Geographic adaptive fidelity</i>
GEAR	Geographic And Energy-Aware Routing
SIR	Sequential assignment routing
SNFG	Stateless Geographic Non-deterministic Forwarding
ACK	Acknowledge
DSR	Dynamic Source Routing
CCS	Concentric clustering scheme
BATR	Balanced aggregation tree routing
PANEL	Position-based aggregator node election protocol
SOP	Self-organizing protocol
TTDD	Two-tier data dissemination
HGMR	Hierarchical geographic multicast routing
GMCAR	Grid-based multipath with congestion avoidance routing
LBDD	Line-based data dissemination
RR	Ring Routing
VLDD	Virtual Line-based data dissemination
HEED	Hybrid, Energy-Efficient, Distributed
MAC	Multiple Access Control
TEEN	Threshold sensitive Energy Efficient sensor Network

Introduction

The innovations in wireless technologies and advances in Micro-Electronic-Mechanical-Systems [1] (MEMS) have given rise to the evolution of low-cost tiny sensors and Wireless Sensors' networks (WSN). WSNs have numerous applications in almost all dimensions of the modern era and are pervasively deployed for information gathering on land, underwater, underground, and multimedia [2]. A WSN is made up of spatially scattered autonomous intelligent sensors to measure environmental conditions. A sensor comprises various components like a sensing unit, memory, processing unit, power unit, and a transceiver [3]. Sensor nodes can be inter-connected themselves and to a powerful machine called Sink or Base Station (BS) through wireless connections. A BS has no power or processing constraints. These WSNs are revolutionizing life in the modern era with numerous applications [4] ranging from battlefield monitoring, underground mines, health tracking of human beings, monitoring of wildlife animals, etc. Unlike traditional wireless communication networks, WSNs exhibit exceptional characteristics such as dense node deployment levels [5] [6], limited on-board energy resources, computational power, storage, and finite bandwidth for data communication [7]. WSN especially the shared sensor networks have been observed to be multi-disciplinary in nature with efforts and knowledge of multiple domains required to support multitude of real-life applications [8]. These unique constraints pose new challenges in the growth and usage of WSNs. The future WSN needs to have communication proficiencies to sustain for a longer duration in the deployed area. For this purpose, it needs energy-efficient communication protocols to minimize communication overhead.

1.1 Wireless Sensor Networks

A WSN is made up of numerous wireless sensors with unique characteristics. A sensor is a tiny and almost inexpensive device that has a limited battery and computation power. It is a type of transducer that senses the physical environment in terms of a signal and converts it to a measurable format for processing. It possesses the capabilities of gathering, processing, and communicating sense data with other connected sensors in a specific network. The basic structure of a sensor node is depicted in Figure 1.1.

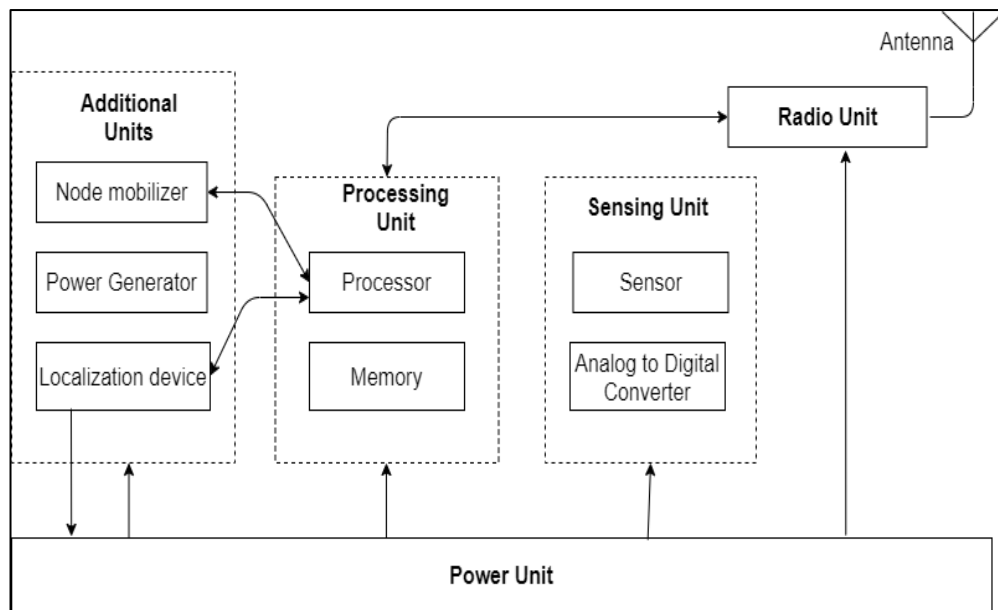

Fig. 1.1 Architecture of Sensor Node

A wireless sensor comprises four units; a radio unit, a sensing unit, a processing unit, and a power unit [9]. A sensing unit includes a sensor along with an Analog to Digital converter (ADC). It is used to sense the intended physical conditions and converting an analog input to digital output. It collects specific physical world parameters such as humidity, temperature, pressure, sound, and light [10]. The processing unit controls the operation of a sensor node in terms of managing processes that allow senses to sense the physical characteristics of the intended entity, execute requisite algorithms and collaborate with concerned sensor nodes using wireless communication mechanisms. It consists of a processor and on-board memory or a small storage unit. A wireless sensor is connected to the rest of the network using its radio transceiver unit, which applies requisite mechanisms for converting data bits into radio frequency signals and recovering the same at the receiving end. The communication between any two sensor nodes is carried out by this radio unit. Every sensor node in WSN is powered with a power unit comprising of a battery with limited life. Every component of a sensor node is expected to operate applying energy-efficient mechanisms so that the lifetime of a sensor node and hence the whole WSN may be enhanced. In addition to these four main units a sensor node may also have additional optional units such as location device to find its location, an additional power source such as solar cells to enhance its network lifetime and a node mobilizer to support movement of sensor nodes to perform intended tasks.

Figure 1.2 presents the block diagram of a sensor node. Because of its modular design approach, it offers a flexible platform to address several applications' needs. As an

illustration, according to the sensors' positioning requirements, the signal conditioning module may be replaced or re-programmed. In this way, a wide variety of different sensors may be used with a sensor node.

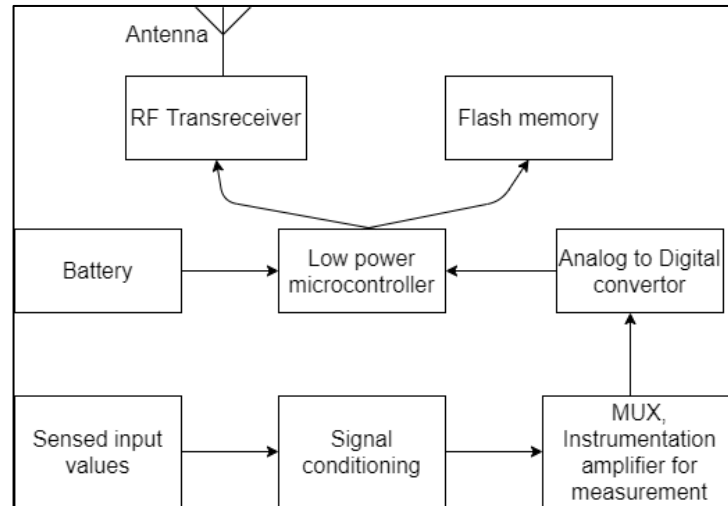

Fig. 1.2 Block diagram for functionality of Wireless Sensor node

In the same way, the radio communication link may be removed as per the requirement for wireless communication for a given application and the necessity for bidirectional communications. Nodes acquire data using flash memory when an event occurs or on-demand from the base station.

1.2 Architecture of Wireless Sensor Network

A WSN, as shown in Figure 1.3, is made up of a large number of sensors that are densely deployed along with sink nodes [11]. The sink is mentoring the sensors for issuing the queries and collecting the results. It also serves as a gateway to other connected networks like the Internet. In order to send sensed data to the sink, the sensor can use both single-hop or multi-hop transmission methods, as shown in Figure 1.5 and Figure 1.6, respectively. Single-hop communication is supposed to be costly in terms of energy consumption as it covers a longer distance. The multi-hop comparatively consumes less energy as it communicates through short distances [12]. Thus, the way the sensor nodes are organized has a profound impact on their lifetime. The multi-hop networks can be classified in two ways: flat and hierarchical [13].

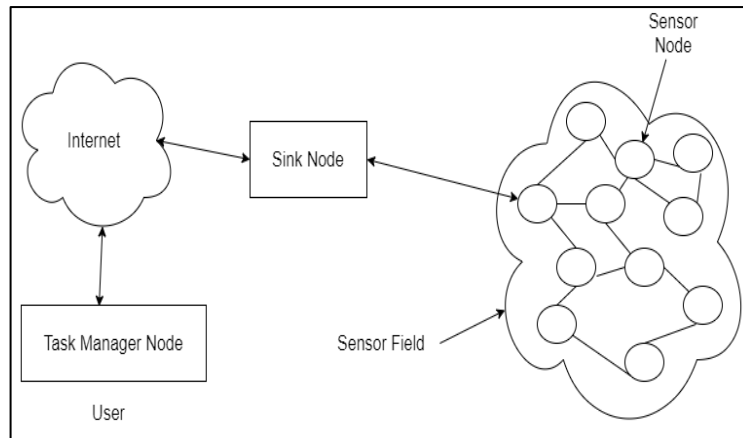

Fig. 1.3 Wireless Sensor Network basic architecture [13]

In a flat network (see Figure 1.4), all the nodes are considered peers and perform sensing [15]. They are generally big in size; hence it is not feasible to get a global identifier for every node. Due to this, data collection is carried out by data-centric routing approach. The communication between sensor and sink takes place via a multi-hop path and uses peer nodes as relays.

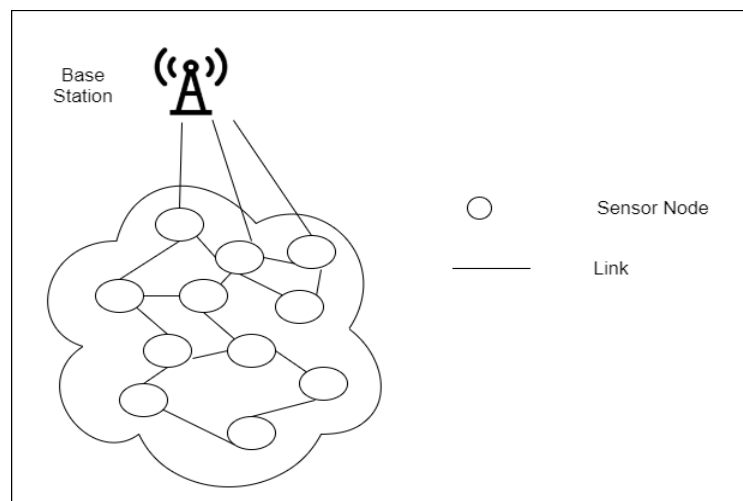

Fig. 1.4 Flat architecture of a Wireless Sensor Network

A hierarchical network is arranged as clusters (see Figure 1.5), where each sensor sends data to the cluster head. The CH work as the relay between the sensor node and the sink node. A CH has a comparatively high energy capacity than the normal sensor node and does data aggregation. This method reduces the need for power and manages the traffic flow efficiently. Here the clustering can be performed periodically to sustain the network lifetime but with a challenge of CH selection [16].

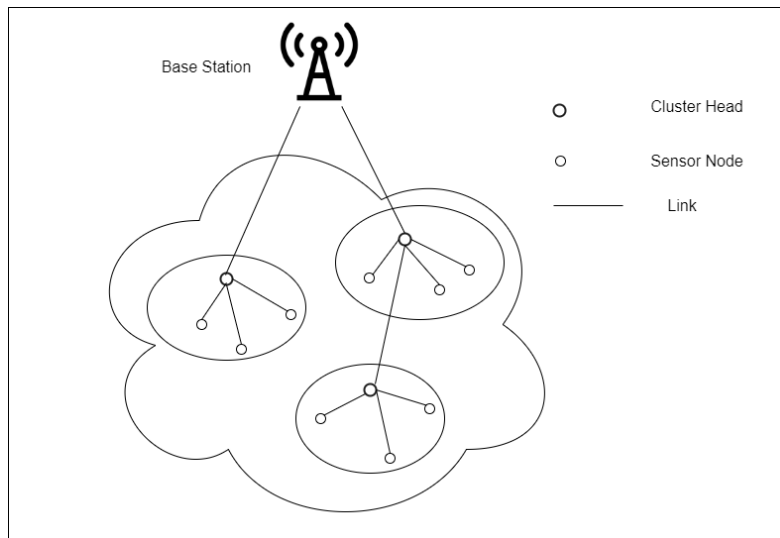

Fig. 1.5 Single hop clustering architecture of a Wireless Sensor Network

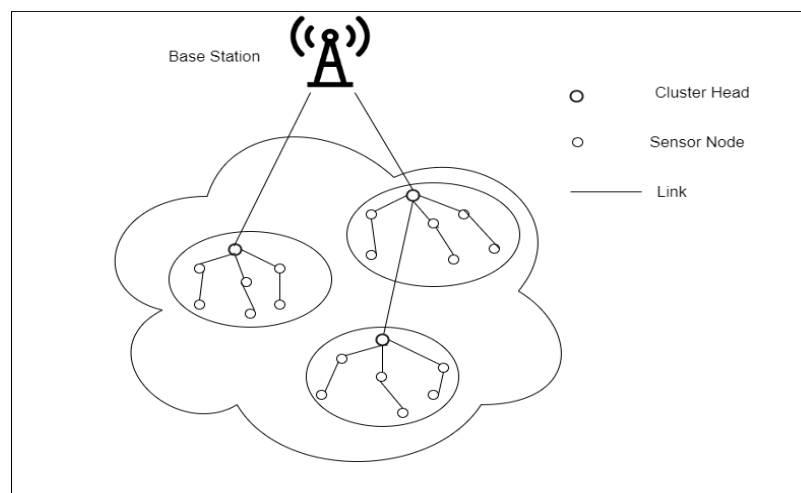

Fig. 1.6 Multi hop clustering architecture of a Wireless Sensor Network

1.3 Types of Wireless Sensor Networks

WSNs can be divided into homogenous and heterogeneous networks depending upon if all the sensor nodes possess the same or different capabilities [26]. WSNs having all the sensor nodes with the same capabilities are called homogenous WSNs. In contrast, a WSN having nodes with different capabilities such as distant sensing and processing power are known as heterogeneous WSNs. For heterogeneous WSNs, it is even more important to develop mechanisms for effective and dynamic coordination of sharing of available resources. Moreover, these mechanisms need to provide optimization of resource utilization while at the same time, meet the application-specific requirements. However, the major concern is that it might not be possible to meet (QoS) requirements of different applications

simultaneously while sharing the scarce networks resources leading to the need to manage an inherent trade-off. Li et al. favoured a middleware platform and extended an existing middleware platform to manage resources in heterogeneous WSNs. Based on their deployment, WSN can be broadly classified into five broad categories[17]:

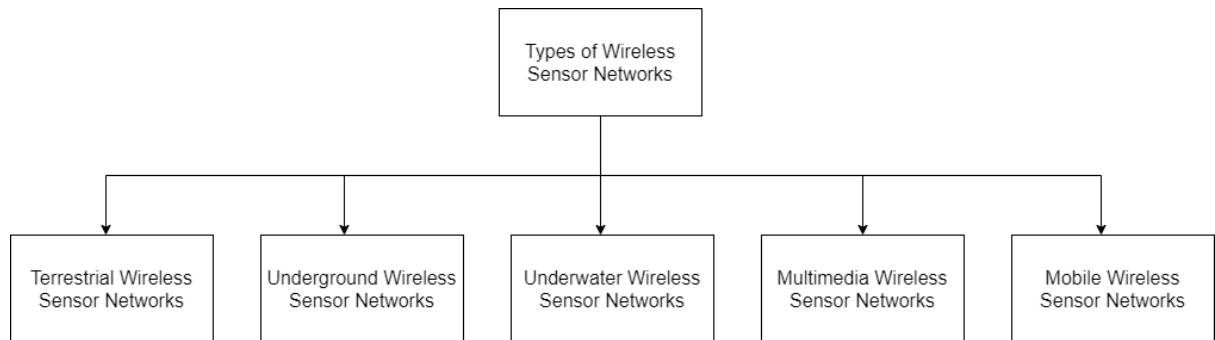

Fig. 1.8 Types of Wireless Sensor Networks

Terrestrial WSNs: They are designed with numerable low-priced wireless sensors engaged randomly over a region of application. Sensor nodes in terrestrial networks may be organized in ad-hoc manner using various deployment models such as grid-placement, optimal placement, 2D and 3D deployment models [18]. The major consideration with these networks is reliable communication in potentially harsh environments, wherein sensor nodes should be able to transfuse among themselves as well as transfer the data to the BS.

Underground WSNs: These networks are made up of numerous wireless nodes buried below the surface of earth to collect information beneath the earth surface usually in an underground mine or cave [19]. Other applications may include monitoring the environmental conditions including changes in soil composition, moisture in soil etc. Base station is situated above the earth surface to enable data collection and communication from sensor nodes to surface station. Underground WSNs are relatively more expensive than terrestrial WSNs with respect to deployment, equipment used and maintenance [19]. In addition to cost, loss of data signal and unreliable data communication are major challenges for underground WSNs.

Underwater WSNs: In this type of network, autonomous underwater vehicles are deployed along with the sensor nodes for underwater exploration and condition monitoring [20]. It is a network that aligns itself to the relatively sparse node deployment in comparison to terrestrial WSN and monitors the intended area via acoustic and optical signals. Some of the challenges for Underwater WSN include delay, limited bandwidth, noise, sensing the

environment underwater and transmission of signal [21]. To design an appropriate topology for underwater WSNs is considered as a major challenge.

Multimedia WSNs: These types of sensor networks comprise of relatively cheap sensors [22] equipped with microphone, camera, and are utilized for monitoring and tracking the intended environment by retrieving images, audio and video information from environment. Some of the prominent applications of multimedia WSN include traffic management, habitat and ecological system monitoring [23].

Mobile WSNs: These networks are characterized by mobility features, where sensors can move to different positions to interact with the physical environment [24].

1.4 Applications of WSN

A WSN is intended to perform information processing tasks such as monitoring, detection, surveillance, etc., and has substantial benefits over wired networks [27]. A wireless sensor node possesses environment sensing capability and monitors numerous physical conditions like sound, light, pressure, composition of the soil, air quality, and

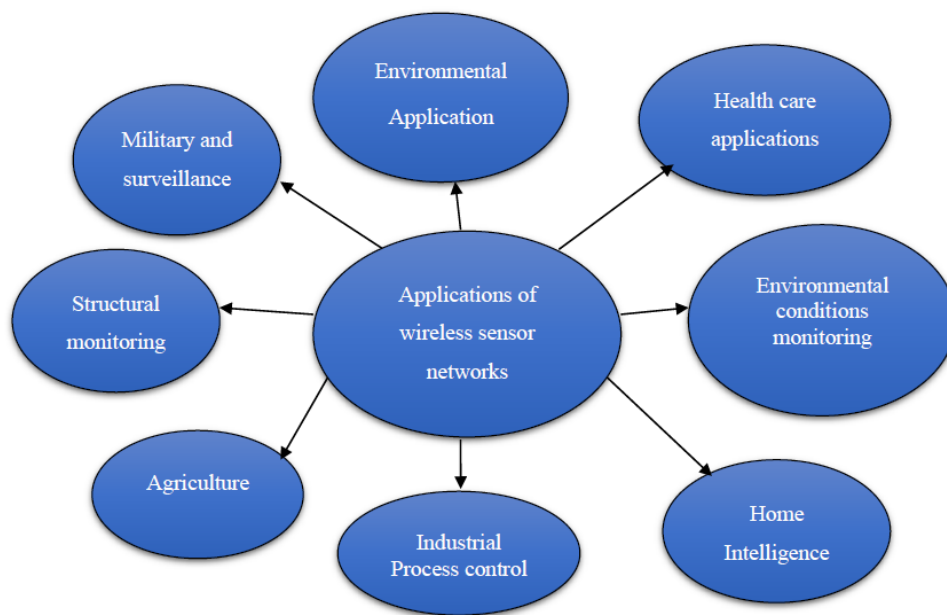

Fig. 1.9 Applications of Wireless Sensor Networks

water quality [28]. Further, it can measure other physical parameters as weight, size, speed and direction, etc. related to an entity. Some of the core applications of WSN are shown in Figure 1.9. Advances in technology are leading to WSN based applications in the Internet of Things which may potentially make use of web services to provide information [29].

Environmental conditions monitoring: WSNs found their early application in sensing and monitoring the environment in various forms on numerous physical parameters that are discussed below:

Water or Air Quality Monitoring: WSNs may be deployed on the Earth surface to monitor air quality. This monitoring of air quality ultimately helps in mechanisms for pollution control. Water quality may be monitored with the help of sensors deployed underwater. Water quality monitoring has its applications in the field of hydrochemistry and helps in controlling water pollution. Alowaidi et al. proposed their work to help the residents in choosing suitable locations according to their preferred environmental conditions by providing statistical analysis to explore the correlation between sensory parameters of quality of air and noise [30].

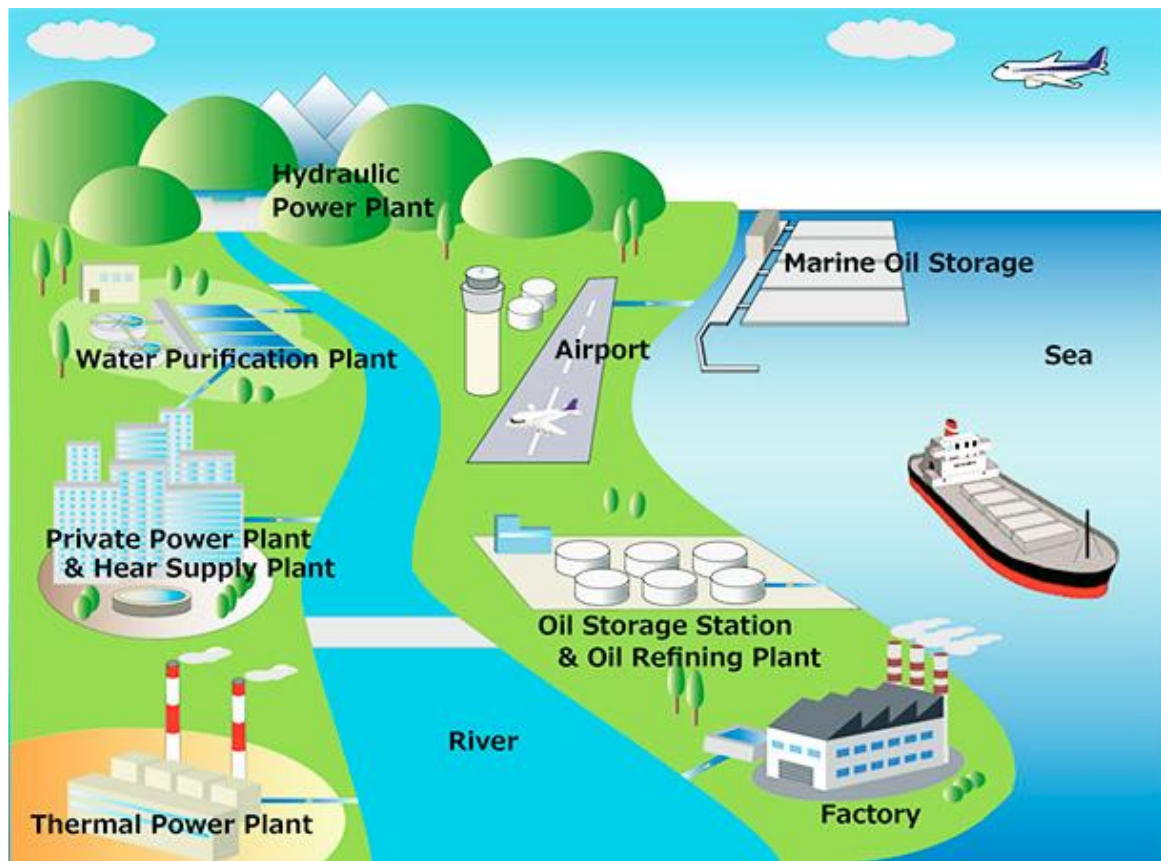

Fig. 1.10 Environment monitoring using WSNs [28]

Habitat Monitoring: Wild animals, birds, and plants can be monitored in their natural habitats unobtrusively with the help of wireless sensors, allowing the wildlife researchers to observe the habitats without any disturbance to the habitats under observation and from

the comfort of their office. The researcher also monitors various physical parameters, including pressure, radiation, humidity, and temperature in which these habitats are living.

Hazard Monitoring: Hazards are chemical or biological changes in specific locations e.g., a gas or chemical plant, a battlefield, etc.

Disaster Monitoring: Disaster can be natural like floods, forest fires, or non-natural like building collapse. The particular sensors can be used or deployed at a certain location to monitor the situation.

Health Care Monitoring: WSNs can be used to monitor patient's health remotely, which can help tackle the issue of shortage in health care staff, further decreasing expenses on health care systems [31].

Smart Home: WSNs in smart homes enable an intelligent living experience. The electrical devices are interconnected and controlled through the sensors e.g., microwave, refrigerator, AC etc. [32].

Medical Industries: In medical industries, different sensors are used to monitor patient conditions, behaviour, etc. It can auto-generate alarm/alert to the doctors or nursing staff for any miss-happening.

Wearable Sensors for Monitoring: These are also termed as body sensors that are wearable or injected to the body part to monitor vital signs. They are used explicitly in monitoring older people's health, infants' conditions, or seriously ill people (see Figure 1.11) [33].

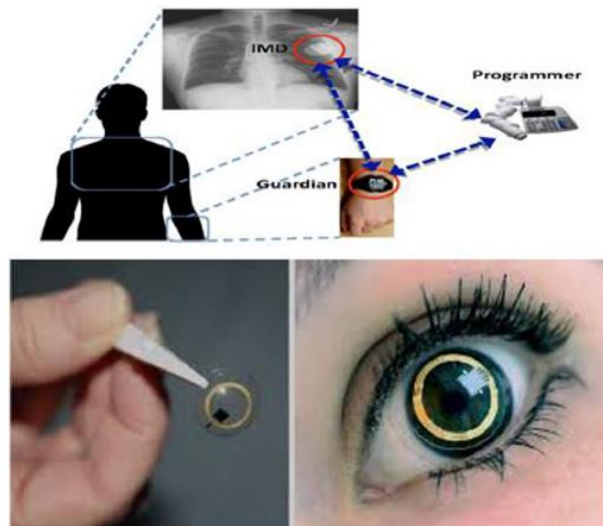

Fig. 1.11 Health care monitoring using WSNs [34]

Industrial Process Control: Industries have several advantages in using WSN for monitoring manufacturing units, equipment conditions, production and assembly line surveillance, etc. Chemical or gas plants need continuous feedback on the status of the

pipeline conditions. Small sensors can be embedded alongside these pipelines to reflect on the state of these pipelines. Further, the maintenance process can be enriched with sensor-based equipment that helps in extending the equipment lifetime.

Security and Surveillance: Several security and surveillance applications like video, acoustic, and cameras are widely used in airports, buildings, railways, subways, and other critical situations like nuclear power plants to keep track of intruders. These help in providing timely alarms and prevention from potential threats. Applications of WSNs may be correlated with health care, surveillance, structural health, business decision making machine learning and collaboration of neural networks with machine learning based approaches is helping in smart decisions [35].

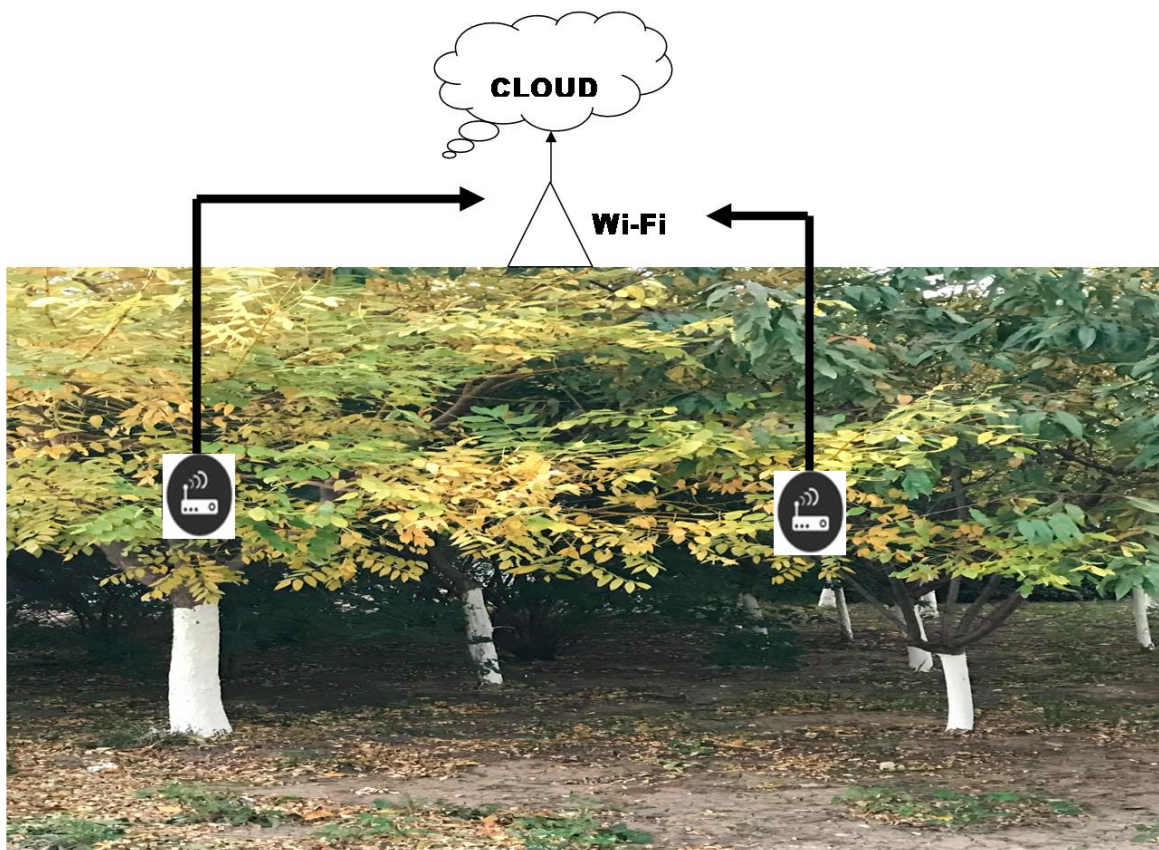

Fig. 1.12 WSN Applications in Forest Monitoring

Military Applications: For military applications, the sensor networks are used in a hostile region, battlefield monitoring, guiding weapons, plotting maps, etc. Hence WSN gives an additional advantage of intelligent and human-less protection mechanisms

Forest Monitoring: Forests play an important role to maintain balance between atmosphere and bio-chemical cycle. Realizing the importance of afforestation, deployment of WSNs is crucial and these WSN based applications are applied in forests. (see Figure 1.12) [28].

Agriculture Process: In the agricultural industry (see Figure 1.13), the use of WSN is progressively prevalent. The wireless network makes farmers free from wire maintenance in a typical environment. Gravity-feeding water supply systems can be observed through pressure sensors to track water tank concentrations, wireless sensor devices can regulate pumps, and the use of water quantity can be evaluated.

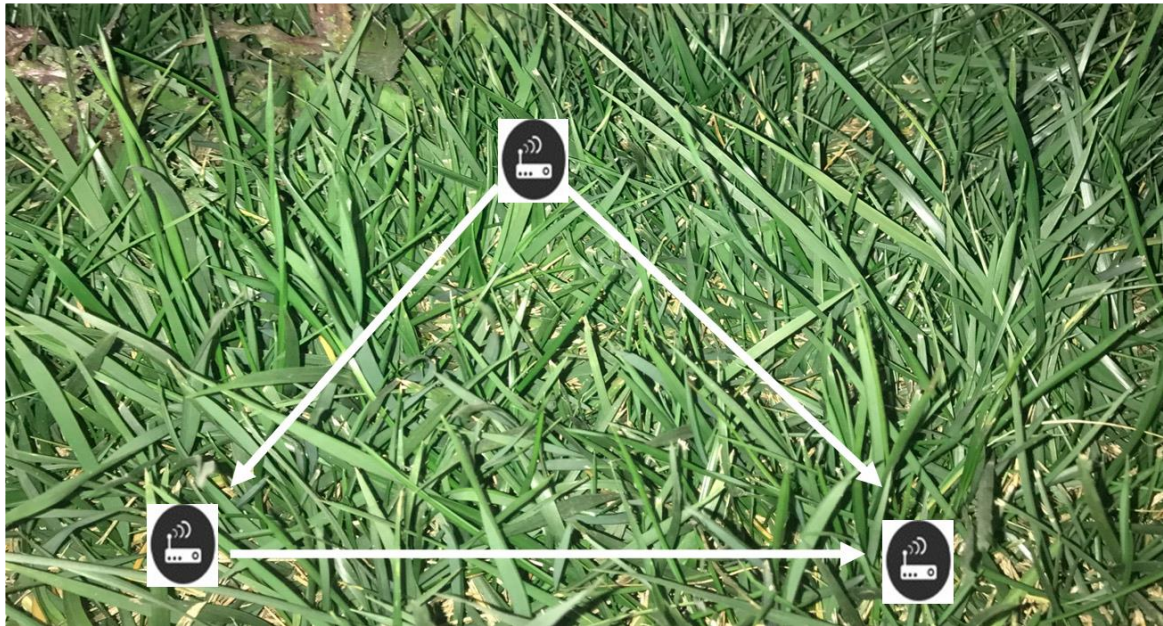

Fig. 1.13 Agricultural applications of WSNs [28]

1.5 Unique Characteristics of WSNs

A WSN comprises tiny battery-operated sensors and is generally deployed in a harsh environment. These sensors do the job of sensing, minor processing, and transmission of information to the BS. The transmission may be limited to short distances or long distances. In comparison to the cellular system and MANET, they have unique characteristics and are discussed below [36]:

Densely Deployment: Sensors are densely deployed in a large geographical region to enable accuracy and precision in observed data. Further, they provide multi-hopping to save energy.

Battery Operated: Mostly, sensors are battery-powered and have a short span of a lifetime. Due to harsh deployment, the replacement or replenishment of the battery is not possible.

Computation, Energy and Storage Constraints: Because of small size and buffer capacity, sensor nodes are limited in energy, computation, and storage capacities.

Self-Configurable: Sensor nodes are generally autonomous and self-configurable. They can communicate themselves with the neighbouring sensors.

Specific to Application: Sensor networks are usually designed for a particular task. They are deployed to observe environmental phenomena based on application.

Sensor Nodes' Unreliability: Since sensor nodes work in an unattended manner and operate in a harsh environment, the sensed data's reliability is questionable.

Adaptable Topology: The topology changes may occur because of a node failure, energy depletion, damage, channel-related issues or addition of sensor nodes.

Lack of Global Identification: Because of dense deployment the global addressing is not possible. It simply adds an overhead to the network.

Data Duplicity: Due to network density and common task assignment, multiple sensors can sense similar data and causes data duplicity.

1.6 WSN Challenges

The unique network characteristics discussed in Section 1.5 give rise to many challenges in making WSN that involve the following main aspects:

Fixed Energy Capacity: Sensors have small sizes and are powered through non-rechargeable batteries [37]. It simply generates hardware and software-related constraint in their manufacturing. These challenges are reflected in network architecture and protocol designing.

Hardware Limitation: Sensors have small storage for storing and processing data. IT simply limits the functional behavior of the sensors. These sensors must be utilized and implemented in WSN and software by considering storage limitations.

Random and Dense Deployment: Most applications prefer dense and random deployment of sensor devices to get more accurate information in a region. These regions are mostly hostile, and the sensors are autonomous. Sensors organize themselves to cater to the services.

Unreliable and Dynamic Environment: The frequent topology changes in WSN due to node failure, the addition of sensors, damages, or energy loss may cause data sensing unreliable. Further, the data may be affected through environmental effects like noise, attenuation, and channel fading.

Varied Application: WSN are used in numerous applications, and the need of each application is different. A specific protocol cannot fulfil the need for such applications. Hence the design of WSN is application-specific.

1.7 Hierarchical Wireless Sensor Networks

Hierarchical-Wireless-Sensor-Networks (HWSN) is a set of wireless sensors that gives its users the capability to monitor, track, and act on events and phenomena in a specific region [38]. The concerned region may include physical entities, biological systems, or some information technology infrastructure. The users of an HWSN may be government, military, civil, medical, industrial, or any commercial entity. The major components of a WSN include an assembly of wireless sensor nodes, interconnecting an ad-hoc wireless network, an establishment of processing resources possibly at a central point. These computing resources are used to handle correlation among data, status querying, event tracking, and data mining. Because of the possibility that large amount of data to be collected by sensor nodes, algorithmic approaches for data management play a vital part in WSNs. Modern WSNs have their origin in defence and industrial applications [39] and have the resemblance to sound surveillance system developed in the 1950s by the military of United States with the intentions to monitor submarines of the USSR. Some of the major concerns with WSNs include limited bandwidth, noise, latency, subsequent transmission, and these factors may lead to potentially unstable data communication. Thus, WSNs need to be explored further regarding their applications so that these concerns may be addressed.

Moreover, a key design consideration is the power or battery life of the sensor device. Sensor devices are limited in energy, with the radio component is the most significant energy depletion source. The energy depletion by the sensor node's radio component depends on the distance to which the data is communicated. More is the distance among source and destination sensor nodes, and more is the energy consumed by radio. There are various approaches suggested in the literature for network lifespan enhancement [40]. The approaches of energy-saving approaches include optimizing radio parameters, sleep/awake techniques, data reduction, energy-efficient routing, and replenishing of sensor battery. To overcome the major issue of energy consumption in data communication, we have procreated energy-efficient hierarchical routing algorithms in this work.

1.7.1 Communication Methodology

Conventionally most of WSNs use Radio Frequency (RF) for communication among sensor nodes. RF may be of millimetre waves or microwaves. RF allows for Omnidirectional communication and does not suffer from the stringent line of sight requirements. Communication among sensors mainly occurs with radio, although many WSNs use optical or infrared communication [41]. Infrared communication is interference-free and is fault-tolerant but has the limitation of being able to communicate in line of sight. In WSNs, for transmitting data to BS, communication can be single-hop or multi-hop. Every sensor node sends its sensed and processed data in single-hop communication to sink directly without any intermediate node in between. It usually leads to data communication over long distances causing higher energy consumption. A sample

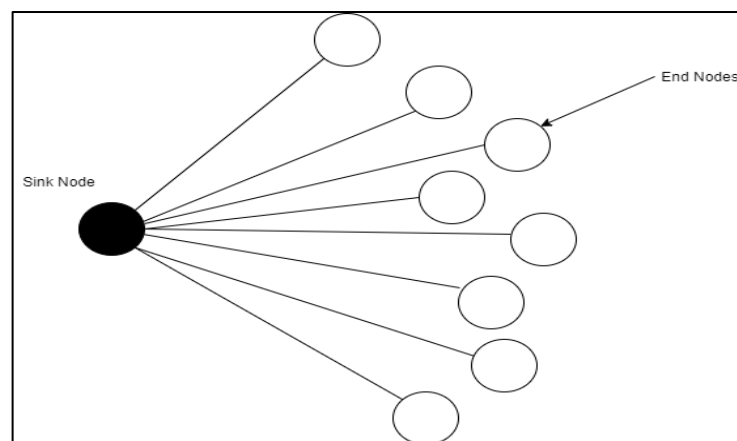

Fig. 1.14 Single Hop communication

of single-hop communication is shown in Figure 1.14. In multi-hop communication, sensor nodes need not necessarily communicate with sink nodes directly. In WSNs, energy consumption for data transmission is higher than data sensing and processing. It grows exponentially for longer distances; thus, single-hop communication may be relatively costly in energy usage [8]; hence, multi-hop communication is preferred. In multi-hop communication (see Figure 1.15), sensor devices send data to intermediate nodes on their way to the sink. Especially in densely deployed WSNs, where sensors are close to one another, short-distance transmission among these sensor nodes is feasible, making multi-hop transmission even more realistic.

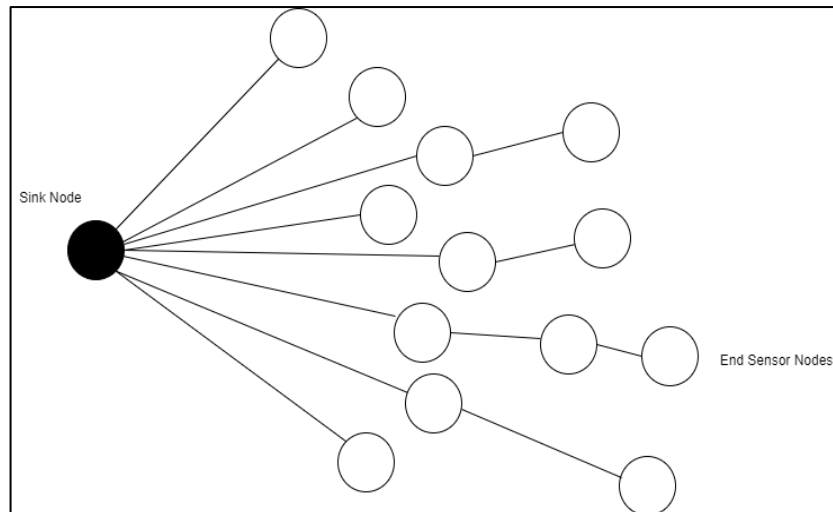

Fig. 1.15 Multi-hop communication

1.7.2 Factors Affecting Routing in HWSN

There are some factors affecting clustering technique in HWSN[42] and are discussed below:

Communication distance: The distance to which the data needs to be communicated has a profound effect on routing. With the increase in distance of communication, the consumption of energy increases exponentially, thus design the routing protocols in such a manner that promotes short distance communication is desirable.

Mobility of nodes or sink: Depending upon the application and design requirements, the WSN may be designed with mobile sensor nodes or sink. Mobility of sensor nodes brings additional complexity as the route setup for communication among nodes or with sink shall have to be dynamic.

Data Reporting requirements: Data reporting is termed as the delivery of data to the application at a critical time. It can be event-driven, query-based, continuous, time-driven, or maybe hybrid [43]. Event and query-driven approaches are reactive and provide instant reporting based on the query. They apply to time-critical applications. For periodic observation of data, time-driven models are best suitable. Hybrid approaches use a combination of these models for heterogeneous applications.

Node or Link Heterogeneity: Most of the research assumes homogeneity of sensor devices with the same capacity. However, an application can have various utility and hence requires heterogeneous sensors, e.g., recording video, sound, temperature, humidity, etc., at the same time. This heterogeneity generates technical issues while sensing, reporting,

processing and routing. Moreover, these sensors may operate at different rates and lead to various service constraints.

1.7.3 Routing Challenges in HWSN

Routing challenges in HWSN are encountered due to limited energy and transmission rate [42]. An energy-aware protocol is required to create and communicate in such networks. Researchers have focused on improving radio communication capability, minimizing duty cycle, and adequate media access protocols. Some of the challenges faced by routing protocol in HWSN are as follows:

Energy Consumption: It is the primary concern while routing in HWSN. The conventional routing approaches are mainly based on distance parameters and are not adequate in HWSN. The other parameters like the neighbourhood, residual energy, node density, and number of CH are equally important.

Neighbourhood Investigation: Neighbour recognition has now become an essential aspect of new routing protocols. Since the information travels through a multi-hop sequence, neighbourhood information plays a vital role in it. The information may vary according to routing methods. The approach uses the concept of gossiping and prevents flooding in the entire network.

Topology Creation: In dynamic HWSN, the location changes occur frequently and generate new challenges for developers. Some data-centric approaches emerge out to support topology change using the agent-based system. The agents are event-driven and are created at an event and forwarded to the neighbouring nodes for information exchange and storage.

Scalability: In HWSN, the sensors are deployed randomly and densely. The routing scheme should support a large group of sensors and respond to the events in the environment. The sensors may remain in sleep mode if there is no event occurs.

Network Dynamics: Some of the researches are based on the assumption that the sensor nodes are static. However, the movement of BS and some of the sensors are sometimes required for better data collection [44]. Routing through moveable nodes and BS is more challenging due to frequent route changes. Further sensing can be either static or dynamic depending on the type of application, as in the case of forest monitoring, it is static and for the tracking system, it is dynamic. Dynamic sensing requires more periodic reporting than static.

Challenges associated with Transmission Media: Since most sensor-based communications are wireless, they tend to suffer from problems related to wireless channels like fading, high error rate, jitter, etc. It may affect the operation of a sensor network.

Coverage: Each sensor has a specific range of coverage and can cover a limited physical area. Hence the coverage capacity of a sensor node is an essential aspect for designing a WSN. Singh et. al. discussed deployment and coverage issues in [45] and compared various deployment methods according to their performance and area of node deployment.

Connectivity: It refers to the approachability of a sensor node to its' neighbour. Random and dense deployment may lead to complete isolation from each other. A node failure may lead to network shrinking and topology failure. Therefore, sensor nodes are to be highly connected and adaptable.

Quality of Service: The sensed data to be transferred instantly when demanded. The delay in data transmission may affect its quality and usefulness. The bounded latency is another required constraint for time-constrained applications. However, some application focuses on conservation of energy rather than the quality of data. It focuses on the reduction in energy dissipation in sensors and extends the network lifetime.

1.7.4 HWSN Creation Strategies

The HWSN creation strategy is classified into three different categories:

Cluster-based: Here, one or more sensors are selected as CH, and the rest of the sensors are joined to the closest CH. The communication is done through the CH in the cluster.

Chain-based: Here the nodes are arranged in a chain-like structure, and one of the nodes act as CH to transmit data to the BS [46].

Tree-based protocols: This is a tree-like structure with a root node and leaf nodes. The data is sensed by leaf nodes and transmitted to the root of the tree.

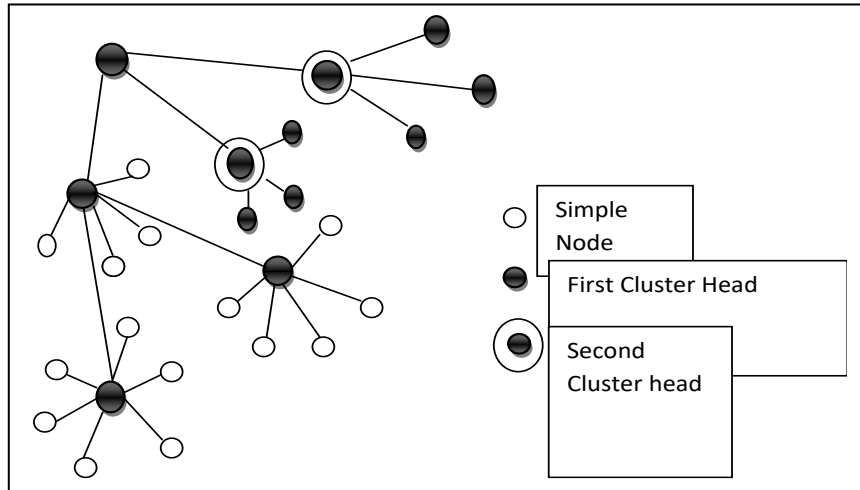

Fig. 1.16 Cluster based HWSN

1.7.5 Routing Methods in HWSN

The hierarchical approach uses a clustering method equipped with a CH, responsible for directing the data to other CHs or BS [47]. The data is higher at the upper layer than the lower clustered layers. Although it passes from node to node, it still looks at large distances that convey quicker information to the BS. The delay in this model is theoretically lower than the multi-hop model. Clustering offers the CHs optimization capacities. The data is initially collected in a cluster and forwarded to upper-level CH in a crystal-based hierarchical model. It reduces travel time and delays while moving from a low to a higher level. Thus, it is better than multi-hop architecture. Also, in a cluster-based model, the CH aggregate data and intermediate nodes enable multi-hopping. The cluster-based model is, therefore, a multi-hop implementation that needs more time. However, there is a disadvantage, as the distance increases, the energy consumed rises in proportion to the distance of the object. Cluster head selection is an overhead cluster imbalance caused due to an uneven distribution of data in cluster can cause concerns in real life applications such as health monitoring oil etc. [48]. Despite the energy costs, the cluster's benefits are better than its deficiency. The cluster-based approaches give better opportunities in HWSN routing.

1.8 Types of Routing Protocol in WSN

In WSNs, the routing protocols are classified into four categories based on established path, network architecture, and working of protocols. Various types of routing protocols in WSNs are shown in Figure 1.17. The primary job of a wireless sensor node is to sense and aggregate data from a region, process it, and deliver it to the application. Direct

communication between sensors and sink involves the transmission of high-power messages and frequent depletion of resources. Thus, the messages are spread in intermediate nodes that divert multiple connections and send them to a sink. The flooding algorithm is a simple solution that transmits transmitted data to deliver the transmitter to the intended target. However, its simplicity has many drawbacks. First, an implosion is defined when intersections are unnecessarily typed in multiple copies of the same information. Later, when many points are detected in the affected area, many data messages are transmitted to the network with the same information.

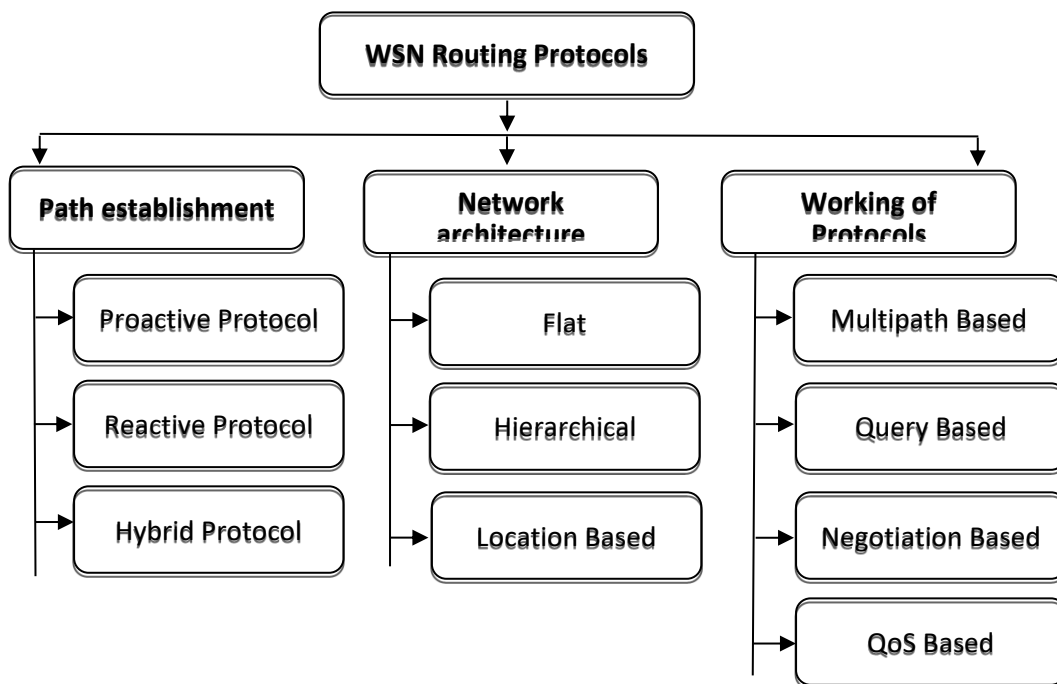

Fig. 1.17 Types of routing protocols in WSNs

1.8.1 Routing Based on Path Establishment

Routing based on path establishment is categorized in three parts: proactive, reactive, and hybrid [49]. These are used to discover the route.

Proactive routing: These are table-driven routing protocols. It maintains the table of routing for the overall network by transferring the network's information within nodes. Routes of this network are predefined, and if paths are changes, then change must be propagated to complete the network. The most common protocols are Optimized link state routing (OLSR) and Multipoint relays (MPRs).

Reactive protocols: This routing protocol doesn't maintain the complete network topology; it finds out the route only when they have required means when any node transmits data to another node. Dynamic source routing (DSR) and Ad-Hoc on-demand distance vector routing system (AODV) are the most common protocols.

Hybrid protocols: These protocols combine both the reactive and proactive protocols by extracting the qualities and removing their drawbacks.

1.8.2 Routing Based on Network Architecture

Based on the network architecture, routing protocols are classified among location-based routing, flat and hierarchical.

Flat routing: This routing protocol treats all nodes equally. It is explicitly used for homogeneous network means where all nodes are of the same features and functionality. A typical example of this network is Constrained-Anisotropic-Diffusion-Routing (CADR), Gradient-Based-Routing (GBR), Rumour-Routing (RR).

Hierarchical routing: Hierarchical routing: In hierarchical routing, the WSN are organized as clusters. Each cluster contains a CH, and other nodes are working as member nodes. These CHs are comparatively rich in energy and can create a hierarchy of communication. Some of the examples of such protocols are LEACH, TEEN, PEGASIS, etc. [42]. In recent researches, these routing protocols have been optimized through bio-inspired routing approaches.

Location aware routing: Here, the nodes can locate their current location through some localization protocols. The knowledge about location helps in enhancing the process of routing and makes WSN provide additional features. Examples of this network are Geographical and energy-aware routing (GEAR).

1.8.3 Routing Based on Working of Protocol

Based on the working of the protocol, routing protocols are classified as negotiation, multipath, query, and QoS based [51].

Multipath routing protocols: It provides various routes for data to arrive at the destination. It enables low delay, load balancing and enhances the performance of the network as an outcome. It also gives the benefit of providing another route if any routes failed. The cost

of power consumption, traffic generation, and network reliability increase due to the alternate path. An example of this protocol is Sensor-Protocols for Information-via-Negotiation (SPIN).

Query based routing: These protocols are generally initiated through a server. The sensor nodes will have the ability to forward a message to the neighbours and satisfies the query produced by the server. The destination node receives the query, collects the data, and sends it back to the node that has requested it. Some examples of these networks are Directed diffusion (DD) and SPIN protocol.

Negotiation based routing protocols: These routing protocols are responsible for reducing the repetition of data transmission; the sensor node negotiates with other adjacent nodes and conveys their information to other nodes about their availability. The decisions for the transmission of data are made after the process of negotiation. Some common examples are SPIN, Directed Diffusion (DD), and Sequential Assignment Routing (SAR).

Based on QoS parameters: These protocol works to enhance the quality of the service. These protocols attempt to determine the route from the client to the server that satisfies the metrics level in terms of fine QoS such as throughput, delivery of data, delay, and energy. The most common example of this network is sequential assignment routing (SAR).

1.9 Thesis Organization

The thesis has been organized in the following chapters:

Chapter 1: Introduction

This chapter discusses the basics of Wireless Sensor Networks, their applications, types, unique characteristics, and critical challenges for WSNs. It focuses on the terrestrial hierarchical wireless sensor networks' communication methodologies, including routing in HWSNs, routing challenges, and routing methods in HWSNs. Keeping the routing challenges into consideration, the chapter also briefs the existing routing protocols in WSNs.

Chapter 2: Literature Review

A comprehensive survey of research work has been carried out in the area of WSNs in this chapter. It highlights various types of energy-efficient routing protocols for WSN. The

chapter focuses on various energy-efficient, classical, hierarchical, nature, and bio-inspired routing protocols for WSNs.

Chapter 3: Research Methodology

The chapter discusses the adopted research methodology to carry out the research work. The simulation software and hardware requirements are also shown in this chapter.

Chapter 4: Fuzzy Multi-Criteria Clustering and Bio-Inspired Energy-Efficient Routing (FMCB-ER)

Keeping the energy-efficient data communication in WSNs into consideration, the chapter presents an approach to provide an energy-efficient cluster head selection mechanism and a communication protocol that enhances the lifetime of SNs in three steps: of cluster formation, cluster head selection, and route identification from SNs to BS. The clusters are created using a grid clustering mechanism. After the grid cluster formation, AHP (Analytic Hierarchy Process) and TOPSIS (Technique for Order of Preference by Similarity to Ideal Solution) methods are combined to make an optimal verdict on CH selection. AF-MCDM considers the three major parameters for optimal CH selection: distance, neighbourhood overlap, and algebraic connectivity. After CH selection Emperor Penguin Optimizer technique is employed for optimal path selection to minimize energy consumption on sensor nodes.

Chapter 5: Multi-objective Based Cluster Head Selection and Energy-Optimized Routing (MCH-EOR)

The chapter discusses the energy-efficient Multi-objective Cluster Head Based Energy-aware Optimized Routing approach for cluster head selection and energy-efficient data communication in WSNs. The process has three significant steps; clustering, multi-objective-based CH selection, and optimization-based route identification for data transmission. It focuses on the problem of traffic overloading near the sink. It has been elaborated in four steps: network setup, energy model, node clustering, and route identification. The network setup phase explains the sensor network creation and deployment. The energy model analyses the energy consumption while transmitting data over the nodes. The node clustering and CH selection present grouping the nodes and creating clusters in the network. In the route identification phase, the optimal path for transmitting the data will be identified by using the SFO algorithm.

Chapter 6: LBNR-LEACH: An Enhanced Energy-Efficient Algorithm for Cluster Head Selection in WSN

This chapter describes the Load-Balanced-Node-Rank-LEACH algorithm for energy efficient cluster head selection. The proposed protocol is an improvement to the existing Node-Rank LEACH algorithm. It considers the network load of candidate cluster heads along with the link quality to select the best cluster head.

Chapter 7: Conclusion and Future Scope

This chapter concludes the thesis and provides the future scope of the research work for energy-efficient data communication in WSNs.

Literature Review

This chapter presents the most comprehensive contributions in the arena of Wireless Sensor Network concerning the data communication achieved through energy-efficient routing protocols. This chapter briefly discusses various mechanisms available for enhancing WSN lifespan, energy-efficient routing, and cluster head selection. It also provides an extensive discussion on optimization-based routing protocols for WSNs. Further, some of the research gaps have been identified and listed at the end of the chapter.

2.1 Routing Protocols in WSN

Routing in WSN is different from wireless or infrastructure networks. A WSN uses multi parametric routing approach for data communication.

2.1.1 WSN Routing Challenges

Some of the known challenges with WSN routing are listed below:

- WSN has no predefined identification schemes, so conventional IP-based protocols do not apply to them.
- The data flow prediction from SN to sink node in WSN is required.
- Due to multiple nodes sensing the duplicate data can be generated. Hence it is vital to identify the redundancy created by these routing protocols.
- Nodes are limited with bandwidth, storage, and transmission range and are different for different sensor nodes.

2.1.2 WSN Routing Techniques

At large, routing in WSNs is divided into two groups: network structure-based and operation-based, as represented in Figure 2.1. The network structure-based approaches can be classified among flat networks, hierarchical and location-aware routing. In flat networks, all sensor nodes are characteristically given similar roles or functionality. Sensor nodes play different roles in the network in hierarchical routing., Positions of sensor nodes are exploited to identify the route in the network in location-based routing. If a routing protocol

can control some of the system parameters to adapt to existing WSN conditions and available energy levels, it is considered an adaptive routing protocol. The operation-based protocols can be classified into multipath, query, negotiation, QoS, or coherent-based routing methods. In addition to the above, routing protocols for WSNs can be classified into proactive, reactive, and hybrid protocols according to the mechanism followed by the node from source to destination. Proactive protocols compute routes before they are required, whereas, for reactive protocols, the path is calculated as and when needed. Hybrid protocols use an approach of combining these proactive and reactive approaches.

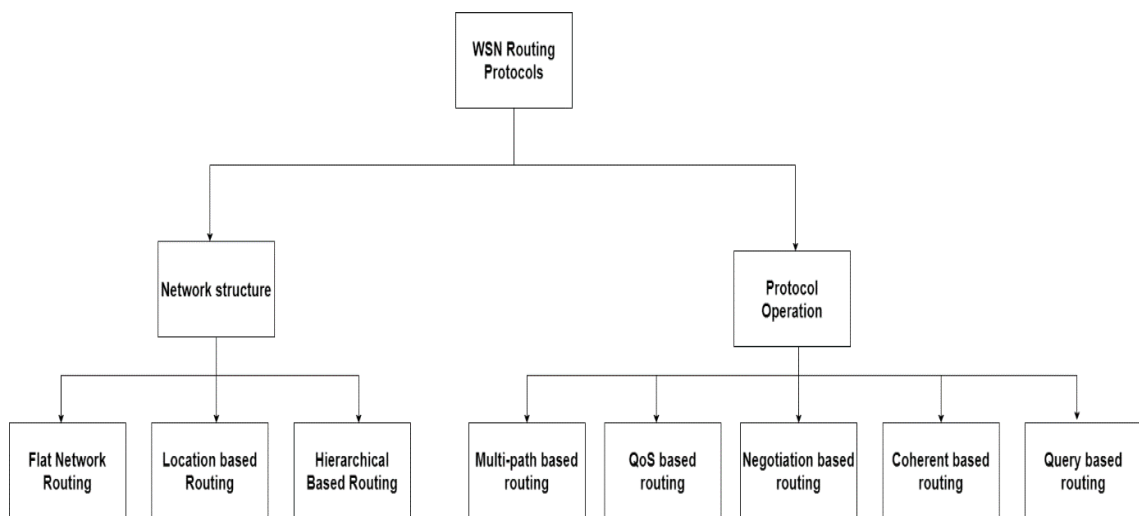

Fig. 2.1: WSN Routing Methods [7]

2.2 Mechanisms to Enhance WSN Lifespan

WSN lifespan depends on the capability of a sensor node to survive for longer durations. For this purpose, the power usage of a sensor needs to be optimized. If any sensor in a WSN depletes its energy, it creates a hole in the WSN. There are many energy-saving mechanisms proposed in the literature for wireless sensor nodes. This section elicits some of the most comprehensive energy-saving mechanisms and shown in Figure 2.2 [40].

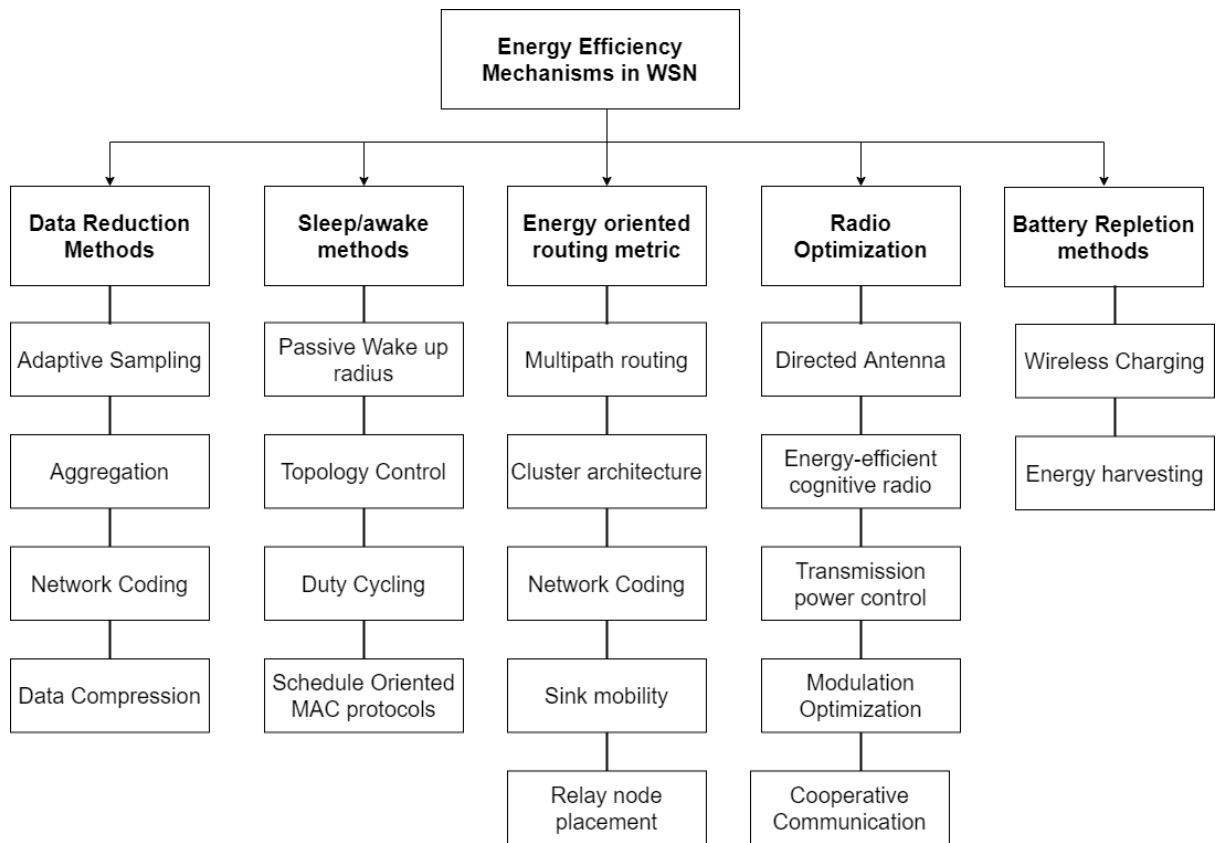

Fig. 2.2: Types of energy saving mechanisms

2.2.1 Optimization of Radio Component

Radio component in a sensor node consumes maximum energy in data transmission. Hence its parameters need to be optimized. Researchers have proposed various methods, including cognitive radio, comparative communication, directed antenna, transmission power control, and modulation schemes. These schemes are briefly described below.

Cognitive radio (CR) is an intelligent radio that can animatedly choose transmission channels in wireless range and adjust its transmission and reception attributes. However, CR consumes substantial energy compared to orthodox devices because of increased new capabilities. Thus, designing WSN based on energy-efficient cognitive radio is a challenge. Recent studies have been carried out for remaining energy-based channel assignment, power control of transmitters [52], and combining CR with network coding.

Cooperative communications approaches are suggested to improve the quality of the received signal by using numerous single-antenna devices that work together to form virtual multiple-antenna transmitters. As data is generally overheard by neighboring sensor node owing to the broadcast nature of the channel. Thus, through these sensor nodes in

retransmission, it's possible to obtain spatial diversity and battle multi-path fading and shadowing [53].

Directional antennas allow unidirectional sending and receiving of signals at a time, to expand throughput and transmission range. They may need localization procedures to be adapted to, with multiple communications happening close immediacy, causing spatial bandwidth reuse. They limit overhearing and, thus, require less power for a given range, leading to improvement of network capacity and lifetime, even influencing connectivity and delay [54].

Transmission Power Control (TPC) improves energy efficiency at the physical layer by regulating radio transmission power [55]. Authors in [56] propose adjusting the transmission power of each sensor node regularly so that it may consider the uneven energy consumption characteristics of the sensor node. So, a SN with higher residual energy can upsurge its transmission power, which can allow other SNs to reduce transmission power, and hence saving energy.

Optimization of Modulation approaches approach is applied to obtain optimum modulation attributes that lead to the lowest radio energy utilization. As energy exhaustion is caused by circuit power consumption and power utilization by transmitted signal, circuit consumption is more than transmission power for short distances.

2.2.2 Data reduction

The amount of data to be transferred also has a profound effect on WSN lifespan with more amount of data transmission and thus more energy depletion. Therefore, this energy-saving mechanism works on the principle of reducing the amount of data communication. It is attained by limiting unnecessary samples, limiting sensing needs, and data aggregation.

In **Aggregation** schemes, SNs along the path to the BS execute data synthesis to diminish data forwarded towards it. It can decrease latency as it causes a reduction in traffic. Here, the aggregation may reduce the accuracy of data.

Adaptive sampling techniques adjust sampling rate at each SN, ensuring application needs are met concerning information precision or coverage. For instance, low-power audio sensors may be applied in a monitoring WSN application to detect intrusion, and when the event is reported, intense power cameras may be turned on to obtain more information [57].

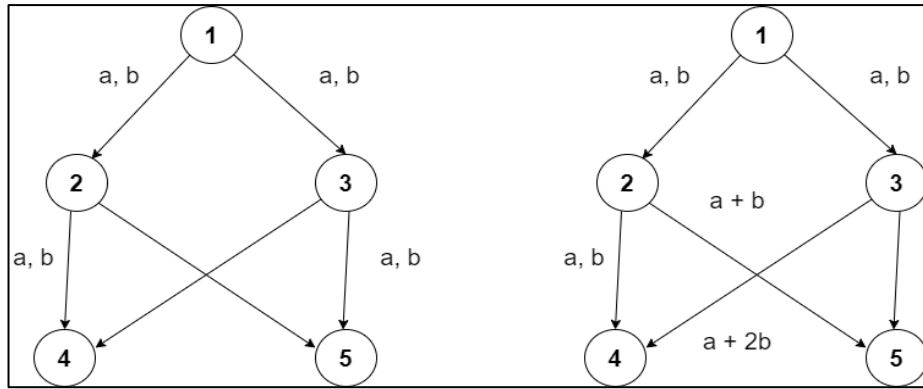

Fig. 2.3 Example of network coding

Network coding (NC) is applied to reduce traffic in broadcast set-ups by transmitting a combination of numerous packets. Figure 2.3 shows an example scenario with a topology of five nodes. In this node 1 broadcast two items. If SNs use the store and forward approach, it shall generate transmission of six packets. With NC, SNs 2 and 3 may communicate a linear combination of data items a and b , sending only one packet. SNs 4 and 5 decode packets by solving linear equations, thus saving two data packets.

2.2.3 Sleep/awake mechanisms

When the sensor nodes are not performing any practical task, their radio component may be sent to a sleep state to save energy. Some of the sleep/awake approaches are discussed here:

The **Duty cycling schemes** schedule node radio state according to the network activity. The approach minimizes idle listening and favors sleep mode. These are generally divided into asynchronous, scheduled rendezvous, and on-demand [57] categories. Though these protocols are considered to be the most energy-efficient, they lead to sleep latency. Also, broadcasting data to all of its neighbors is not feasible as neighbors are not active at the same time. Lastly, fixing attributes, such as listening and sleeping, slot time, and preamble, can be challenging as it affects network performance. Moreover, schedulers may have an impact on how much data arrives at the base station. Lee et al. proposed a multi-level queue scheduler approach using a different number of queues based on the location of SNs [58] and showed that their proposed approach allowed for more amounts of data to be delivered to sink within the deadline in comparison to the traditional FCFS scheduling scheme.

Passive wake-up radios, Ba et al. present a network comprised of passive RFID wake-up radios, WISP Motes and RFID readers [59]. Passive RFID triggers radio employs energy spread by reader transmitter to induce an interruption that wakes up the SN. The concept allows two types of radio usage - one having high energy and another having low energy. The low power radios awake a node in the duty cycling approach, whereas the high-power radio transmits BS.

Topology control approach enables the deactivation of some of the nodes in the redundantly deployed WSN. Deactivation allows the longer lifetime of the sensor network when not in use. These protocols use redundancy to adapt network topology according to the requirements of the application animatedly. Recently Karasabun et al. show the problem of choosing a subset of connected active SNs for correlated data gathering [60] which is beneficial in environmental monitoring applications.

2.2.4 Energy-Efficient Routing

Route identification process can drain the energy reserves of SNs. Especially in multi-hopping SNs closer to BS are strained as they need to route more packets causing faster battery drainage. In [61], one can find an all-embracing review of energy-aware routing protocols.

Cluster architectures organize WSN into clusters, with each cluster has a leader called Cluster Head (CH) that manages cluster member (CM) nodes and thus the whole cluster. CH manages cluster member nodes' activities and coordinates with other CHs and BS. Also, energy saving is obtained through the rotation of cluster heads [62].

Energy as a routing metric permits the routing algorithms to emphasize shortest paths and elect the next hop for communication-based upon SN's residual energy. Liu et al. presented new energy-conscious cost functions of Sine Cost and Exponential function to route the data [63]. These cost functions map small changes in residual energy of SN to comprehensive changes in the value of cost function. Thus, cost function provides energy balance by giving priority to SNs with more residual energy while selecting the route.

Multipath routing aids in energy to be balanced among SNs by rotating forwarding SNs. One such protocol, EEMRP (Energy-Efficient Multipath Routing Protocol) uses a cost function based on energy levels and hop distances between SNs to identify multiple node-disjoint paths and distributes traffic rate for each selected path [64]. Multipath routing

protocols have an additional advantage of improving network dependability with numerous routes, which empowers WSNs to recover sooner from node failures.

Relay node placement can help in reducing energy hole or network hole problems. Optimum SNs deployment with even distribution use of relay nodes (RN) with greater proficiencies may help to eradicate energy hole concerns. It helps in improving energy balance among SNs, avoids hot spots, and ensures complete coverage and connectivity among SNs [65]. Research work has been carried out to find out the minimum number of RNs or to place the SNS in optimal fashion network lifetime may be prolonged [66] [67].

Sink mobility can help in reducing the distance between BS and the sensor nodes. In WSN architectures that use a static BS, SNs closer to the BS deplete their energy quickly than other SNs, causing untimely disconnection in the network. This is because all traffic is accelerated towards the sink, causing increased workload for SNs near BS. To improve WSN lifespan, a mobile BS that can move around the network may be employed to collect data and balance the load among sensor nodes. Sink mobility helps in improving the connectivity in the sparse deployment of SNs and enhances WSN reliability as communication with BS occurs in a single-hop fashion and leads to a decrease in collisions, contention, and message loss [68].

2.2.5 Charging Solution

Numerous recent research studies propose new ways to improve energy efficiency with energy harvesting and wireless charging techniques.

Energy harvesting Energy harvesting allows sensors to harvest energy from their surroundings like wind, solar, and kinetic energy [69]. Compared to conventional SNs, rechargeable motes can operate continuously for a longer duration, supposedly for an unlimited time. These nodes transform ambient energy into electrical energy and then either consume this energy directly or store it for use later when required. Energy harvesting architectures usually require energy prediction methods to manage the available energy efficiently. Energy prediction is necessary for energy harvesting sensors to adjust their behavior dynamically and stay alive till the next recharge cycle. Thus, they may be required to optimize decisive parameters including duty cycling; sampling rate and transmit power as helps these SNs adapt their energy consumption consistent with the periodicity and magnitude of the harvestable source. It is essential to understand that SNs remain energy

constrained in between two harvesting opportunities, and hence they still need to apply energy-saving approaches. For instance, motes having solar panels for replenishing their batteries can operate intensively in the daytime and may enter into the conservative mode at night to sustain themselves using available energy. Also, SNs can have uneven remaining energy because of variations in the quantity of energy collected during the energy harvesting period. This factor needs to be given importance to while designing protocols [70]. Possibly the SNs with lower remaining energy may be assigned higher sleep periods and lower communication ranges. At the same time, SNs with higher remaining energy may be given priority while selecting a routing path. Also, development of protocols that reflect the degradation of the battery over time in terms of storage, leakage, and loss) [71] needs to be given due consideration as it will have an impact on network performance.

Wireless charging is a recent breakthrough in wireless technology. The wireless power transfer is expected to enhance WSN sustainability and make them operational potentially, forever. Wireless charging solutions can transmit power from one device to another without any physical contact between the transmitter and receiving nodes. WSNs attain Wireless charging in two ways: viz. magnetic resonant coupling and electromagnetic (EM) radiations. Xie et al. show in their research that omnidirectional electromagnetic radiation technology is pertinent for WSN with shallow power requirements, especially for relatively low sensing activities like light, temperature, and moisture [72]. It happens so because EM waves may suffer from a quick drop in power efficiency with an increase in distance. Also, active radiations may pose safety apprehensions for humans. On the other hand, magnetic resonant coupling seems to be the more capable technique to address the energy requirements of WSNs due to their higher efficiency within a several-meter range. Applications of wireless transfer of energy in WSNs have already been applied in implantable devices and medical sensors [73], for replenishing energy in sensor nodes embedded in concrete by wireless means [74] and to providing energy to a ground sensor from UAV [75]. However, the advent of wireless charging technologies gives rise to new challenges as sensor nodes shall now share energy with their neighbors leading to energy cooperation. So, in future WSNs, SNs shall be able to harvest the energy from environment and be able to transfer energy to other SNs, improving the network sustainability [76].

2.3 Classification of WSN Routing Protocols

Data communication is the prime source of energy depletion in WSNs with distance playing a vital role in it. Transmission and reception of data in an energy-efficient manner is

extremely beneficial in enhancing the lifespan of a WSN. Many modern, routing protocols for WSNs have been developed over time keeping energy efficiency as a prime factor into consideration. This research classifies routing protocols into classical and optimization-based routing protocols. According to their network architecture, classical routing protocols can be further alienated into three broad categories: Data-centric routing, Geographical location routing protocols, and Hierarchical routing protocols. Due to the proven proficiency of Hierarchical routing protocols in saving WSN energy, the research concentrates more on hierarchical routing protocols which are further divided into chain-based, tree-based area-based and grid-based approaches. The summary of the available approaches is shown in Figure 2.4.

2.3.1 Data Centric Protocols

Data-centric protocols use attribute-centered naming to describe data attributes. BS communicates queries to designated areas and waits for a response from SNs of those particular areas [77]. Several protocols belong to this category of protocols including Energy-Aware Routing (EAR), Sensor Protocol for Information via Negotiation (SPIN), Rumour Routing, Gradient-Based Routing, Directed Diffusion (DD) protocol, ACtive QUery forwarding In sensoR nEtworks (ACQUIRE), COUGAR, and Constrained Anisotropic Diffusion Routing (CADR). The main limitation of data-centric routing protocols is scalability which is a major concern with WSNs. Usually, a large number of SNs work in tandem in a WSN application. Here some of the prevalent data-centered routing protocols are discussed below [78].

Sensor protocols for information via negotiation (SPIN): SPIN [79] employs a mechanism of advertisement in which the metadata is exchanged among SNs. Each SN advertises data to its neighbors after receiving it. Interested neighboring nodes then retrieve data by transmitting request messages. An advantage of the SPIN is that SNs need to know their single hop neighbors only. The problem of Resource Blindness is taken care of by SPIN. Also, it does not allow for any redundant information to pass through thus attaining energy efficiency. The drawback of SPIN lies in that it does not assure delivery of data. For instance, in case of destination SN is at a distant location and SNs that are intermediate to source SNs and destination, are not interested in delivering data to the destination node.

Directed Diffusion: This approach [80] uses the concept of named attribute-value pair and reinforcement of path [81] and communicates data with the naming scheme of data. DD uses the attribute-value pairs to get data in an on-demand fashion and queries the SNs with

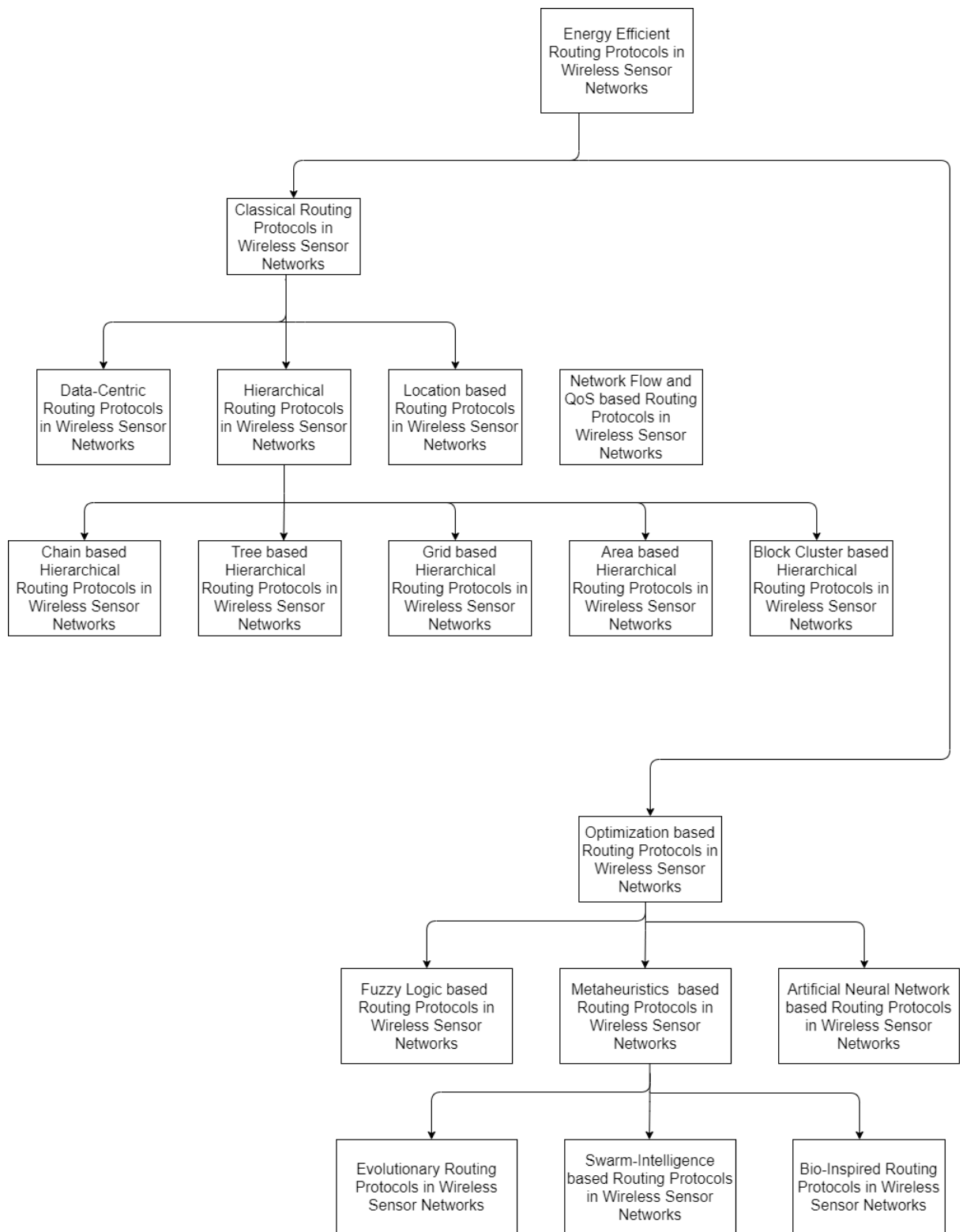

Fig. 2.4 Classification of routing protocols in Wireless Sensor Networks

those pairs. A list of attribute-value pairs is used for the creation of a query. When BS needs information about a specific attribute, it broadcasts the interest messages to all of its

adjoining SNs. These interest messages get swamped in the entire network and get added to the interesting cache of every SN. Each record in the interesting cache has one or more gradients that correspond to adjoining SNs which transmitted the interest. This gradient also records the rate of data requirement, timestamp, and interest timespan. When an SN produces data, matching with an interest in its cache, it sends back data to the source with gradients. Instinctively, the data is drawn to the sink with the help of gradients. The sink node can reinforce the shortest path i.e., the path with the fastest response, by communicating an interest with a higher data rate along the path. Intermediate nodes circulate reinforcement by probing a local cache of recently sent messages. Data cache also helps in preventing loops in data delivery. Negative reinforcement or interest messages with a slow data rate may be sent to slower data paths to save network bandwidth. In case, a sink wants to keep receiving data it must periodically reinforce the path to update the timestamp and duration in the gradients [82].

Energy Aware Routing: Rahul C. et al. proposed the use of sub-optimal paths for improving network lifespan [83]. These sub-optimal paths are designated with the help of a probability function, that is based on energy consumption at each point. Numerous paths are used with a specific probability so that the entire network gets a chance and the energy of SNs doesn't get exhausted.

Rumor Routing: David Braginsky et al. proposed this protocol. It is another variation of Directed Diffusion and is primarily envisioned for applications where location-aware routing might not be feasible [84]. Fundamental idea is to route the queries to only those SNs that have observed a particular event instead of flooding the entire network for retrieving information about occurring events. For flooding events in the network, this approach uses agents, which are long-lived packets. As soon as an SN detects an event, it adds this event to its local events table and generates the corresponding agent. This agent travels the network for propagating information about local events to far away nodes. When SN generates a query for an event, the nodes aware of the route can respond to the query by examining its event table. Therefore, there is no need to flood the whole network, thus reducing the communication cost. Rumor routing accomplishes substantial energy savings when compared to event flooding and can handle the failure of SNs. The limitation of rumor routing is that it works well only in case of a small number of events. The cost of sustaining agents and event tables for each SN becomes infeasible when the number of events is large.

Constrained Anisotropic Diffusion Routing (CADR): Maurice Chu et al. proposed a general form of the Directed Diffusion approach: to query SNs and route data in the network so that latency is minimized though information gain is still maximized. CADR [85] circulates queries in the form of information criteria to select SNs that can get data. It is accomplished by activating only those SNs that are closer to an event, dynamically adjusting the routes. The principal alteration from DD is the deliberation of the information gained in addition to communication cost. In CADR, each node estimates the cost objective and routes the data according to local cost gradient and requirements of end-users.

COUGAR by, Yong You et.al., provides a network layer independent method for data queries. In their view WSN is a massively distributed database system [86]. This approach employs declarative queries to abstract query processing from network layer functions, including selecting relevant sensors and so on. COUGAR employs in-network data aggregation to attain energy gains. COUGAR includes architecture for the sensor database system SNs select a leader node that performs aggregation and transmits data to the BS. The query plan also defines a method to select a leader for the query. Successful in-network data requires synchronization amongst SNs, computation before sending data to selected CL. To avoid the problem of the hot spot, leader nodes should be animatedly maintained.

Active QUery forwarding InsensoR nEtworks (ACQUIRE): Narayanan Sadagopan et al. proposed ACQUIRE [87] that interprets the network as a distributed database dividing complex queries into numerous sub queries. BS sends a query, which is then forwarded by each SN receiving the query. Each node tries to respond to the query partially by using information cached earlier and forwarding it to another SN. In case, pre-cached information is not appropriately up to date, SNs collect information from their respective neighbors within look ahead of n hops. After the resolution of the query completely, it is transmitted back through either the shortest path or in the reverse direction to BS. ACQUIRE can deal with intricate queries by allowing many SNs to send responses. For selecting the next SN to forward the query, ACQUIRE either select it randomly or is selected, keeping criteria of the maximum potential of query satisfaction into consideration.

2.3.2 Geographical Routing Protocols

In some WSN based applications, geographic location awareness is desired to calculate the distance between participating SNs [88] to estimate energy consumption. Location awareness information can route the data among SNs spatially spread over a deployment

region energy efficiently. Geographic Adaptive Fidelity (GAF), Minimum Energy Communication Network (MECN), Small Minimum Energy Communication Network (SMECN), Geographic and Energy Aware Routing (GEAR), etc., are Some of the location-based routing protocols. Location-based protocols can be helpful, but the availability of localization devices and reliability of localization techniques can be a challenge.

Minimum energy communication network (MECN): Volkan Rodoplu et al., in their research, present an approach that utilizes low power GPS to set up and preserves a minimum energy network for wireless networks [89]. The approach considers an information sink, a master site, and a relay region are identified for every SN. The relay region comprises of SNs in an adjoining area where transmission using those nodes is comparatively more energy efficient than straight transmission. Figure 2.5, redrawn from [89], represents the relay region for node pair (i,r) . The enclosure of a given node i is produced by taking a combination of all relay regions that can be reached by sensor node i . Thus, the key idea behind MECN is to find a sub-network that has a smaller number of SNs and consumes less energy for transmission between any two SNs of interest. Global minimum power paths are identified without considering all the SNs in the network using a localized search for each node considering its relay region.

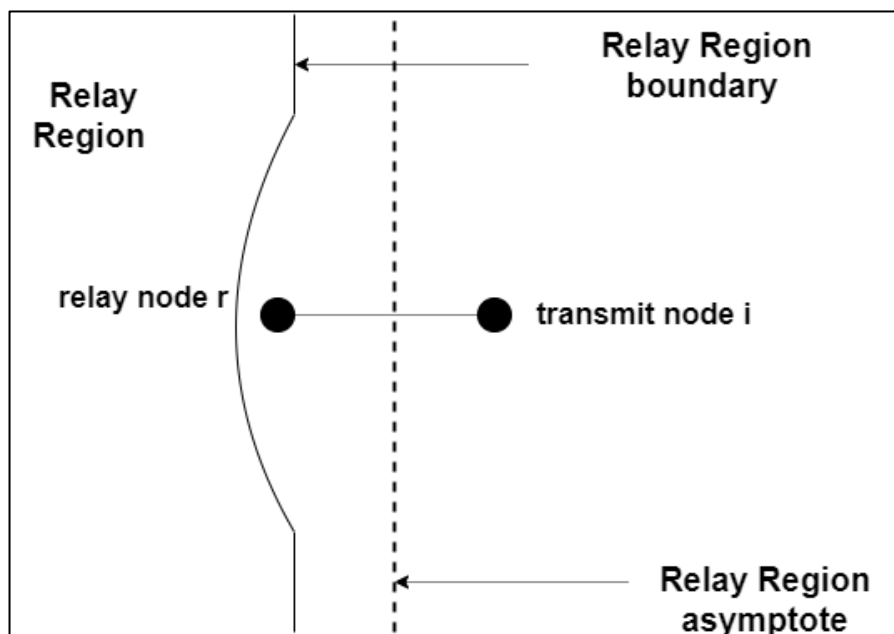

Fig. 2.5 Relay region for transmit-relay node pair (i, r) in MECN [89]

Small Minimum Energy Communication Network (SMECN): Li Li et al. proposed (SMECN) [90] an extension of MECN [89]. SMECN considers possible obstacles between

any pair of SNs. Although similar to MECN, the network is assumed to be fully connected, the sub-network created by SMECN is demonstrably smaller in terms of the number of edges than the one created in MECN if broadcasts can reach all SNs in a circular region around the broadcaster, thus reducing the number of hops for transmission.

Geographic adaptive fidelity (GAF): Ya Xu et. al. in [91] proposed a location-based, energy-aware routing algorithm designed principally for mobile ad-hoc networks, but is also applicable on sensor networks. GAF turns off the redundant nodes to conserve energy and form a virtual grid for the covered area. Each node utilizes its location as given by GPS to associate itself with a point in the virtual grid. Nodes allied with the same point on the grid are considered alike in terms of the cost of packet routing. To save energy, such equivalences are utilized to keep some nodes, located in a particular grid area, in a sleeping state. Thus, GAF can significantly increase the network lifespan as the number of SN increases. Figure 2.6, redrawn from [91] shows a sample situation. In this figure, node 1 can communicate with any of nodes 2, 3, and 4, and nodes 2, 3, and 4 can communicate with node 5. Thus, nodes 2, 3, and 4 are equivalent and two of these nodes can go to sleep state. To balance the load, nodes take turns to change states from sleep to active. There are three main states defined in GAF protocol and they are discovery, to find the neighbours in the grid, and reflecting active participation during routing including sleep when the radio is switched off. The state transitions in GAF are depicted in Figure 2.7.

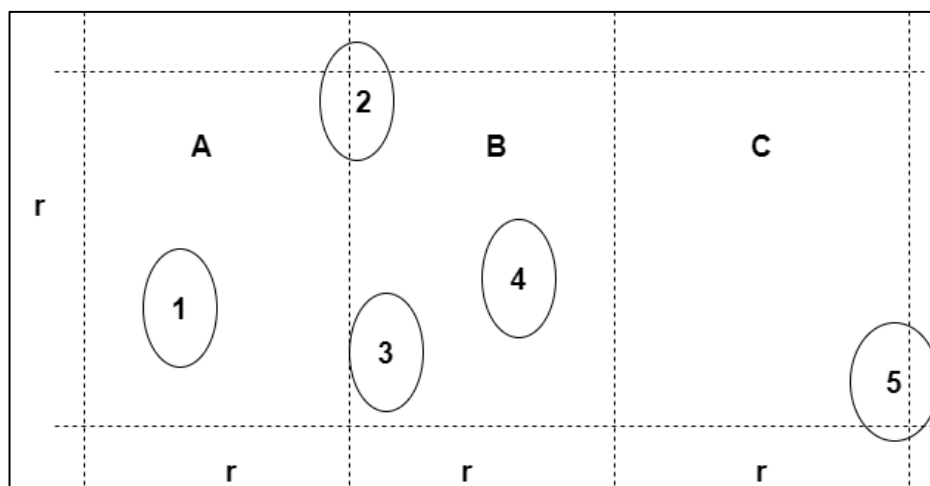

Fig. 2.6 Example of virtual grid in GAF [91]

Which node will sleep for how much duration depends on the application in consideration and accordingly related parameters are adjusted during the routing process. Every node of the grid estimates its' leaving time from grid and sends this to its neighbors, for the purpose

of handling the mobility. The sleeping nodes in neighbors adjust their sleeping time accordingly to ensure routing fidelity. Before the expiration of leaving time of the active node, the nodes which are in a sleep state, wake up and one of them goes to the active state. Thus, GAF endeavors to keep the network connected by keeping a representative node always in active mode for each region on its virtual grid.

Geographic And Energy-Aware Routing GEAR: Yu et al. have suggested the use of location information of SNs while circulating queries to suitable areas [92]. It applies energy-aware as well as geographically apprised neighbor election heuristics to forward a packet towards a destination area. It restricts the number of interests in the Directed Diffusion approach by considering only a specific region rather than broadcasting interests to the whole WSN, thus complimenting Directed Diffusion and preserving more energy. In GEAR, each node possesses an estimated cost and a learning cost to reach the destination via its neighbors. The estimated cost is a combination of distance to the target node and residual energy. The learned cost is an enhancement of the expected cost and considers routing near holes in the network.

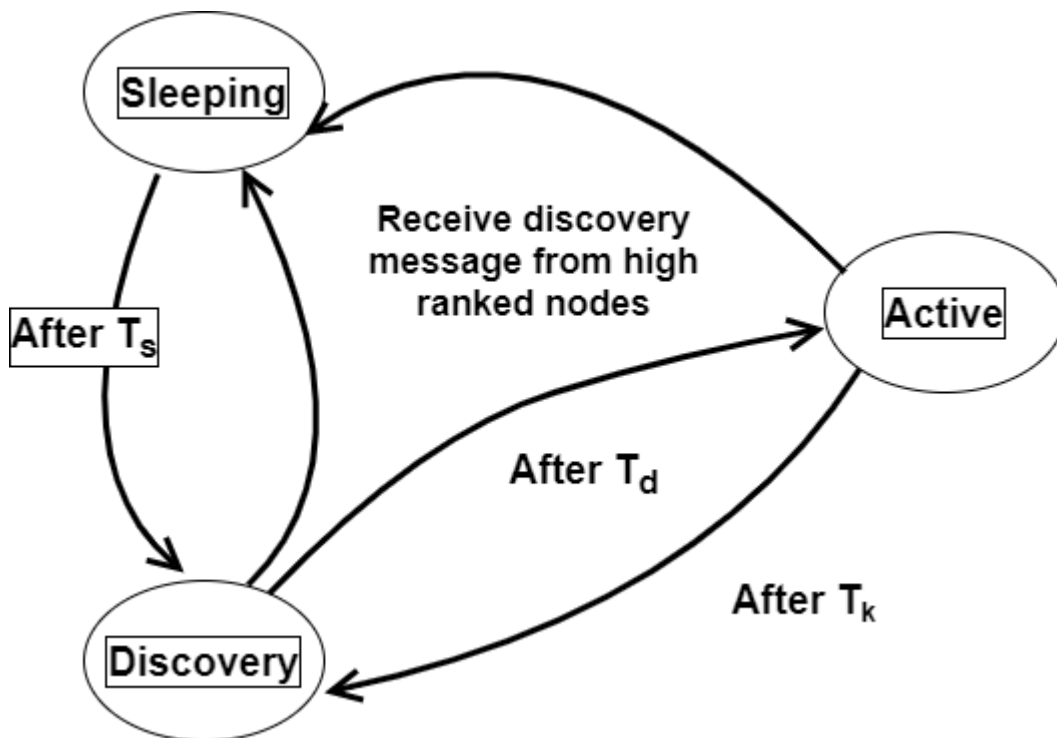

Fig. 2.7 State transitions in Geographic Adaptive Fidelity routing

2.3.3 Network flow and QoS aware routing protocols:

In some approaches, route setup is modeled and solved as a network flow problem. QoS-aware protocols consider end-to-end delay requirements while setting up the paths in the sensor network.

Maximum lifetime energy routing: Chang and Tassiulas gave an interesting resolution to the problem of WSNs with a network flow-based approach [93]. The approach makes the best use of the network lifespan by carefully defining link cost as a function of necessary transmission energy using that link and remaining energy. The authors presented two algorithms with a maximum residual energy path to find out the best link metric according to the established maximization problem. Two approaches are different in their link costs, incorporation of SNs residual energy.

Maximum lifetime data gathering: Kalpakis et al. applies data routes setup in WSNs as the maximum lifetime data gathering problem and gives a solution with polynomial-time algorithm [94] Number of rounds for which a WSN can sustain before the first sensor dies is defined as lifetime “T”. The schedule of data-gathering describes the method of data collection and routing it to BS with the help of a tree for each round directed from the BS and extends to all the nodes in the system. The validity of the schedule determines the system's lifetime. An algorithm called maximum lifetime data aggregation (MLDA) has been proposed to maximize the lifespan of the schedule. An optimal admissible flow network that is a flow network with maximum lifespan answerable to the energy constraints of SNs is defined. After this, a schedule is created with this admissible flow network. The scenario called maximum lifetime data routing (MLDR) is presented as a network flow problem with energy constraints on SNs. A solution to this problem using integer programming is presented. Both MLDR and MLDA are realized and compared with hierarchical-PEGASIS [95]. The results show that on the parameter of system lifespan, both of these algorithms perform well than hierarchical- PEGASIS, though in MLDA the delay is slightly higher than hierarchical- PEGASIS is found to be computationally expensive for very large WSNs.

Minimum cost forwarding: Fan Ye, et.al. proposed a protocol that aims at finding a path with minimum cost in a large WSN [96]. The cost function of the protocol takes throughput, delay, and energy consumption. First, a setup phase to set the cost value of all SNs starting from BS and spreads in the network is performed. Each SN fine-tunes its cost value by

adding the cost of SN it received the message from as well as the cost of the link using a back-off-based algorithm to the bound number of messages exchanged. Forwarding of message is delayed by a predetermined interval so that a message with a minimum cost may arrive. Thus, the algorithm finds the optimum cost of all SNs to the sink by making use of only one message at each node. The protocol does not necessitate any addresses and forwarding paths with optimal forwarding being achieved with a minimum number of advertisement messages and achieves good energy efficiency [97].

Sequential assignment routing (SAR) is the first protocol with QoS considerations in routing decisions for WSNs [98]. It is a multi-path, table-driven method trying to attain energy efficiency as well as fault tolerance. It creates trees that are rooted at one-hop neighbors of BS by keeping QoS, priority level of every packet, and energy resource on each path into consideration. With the help of these trees, multiple paths from BS to SNs are molded and one of these paths is elected as per QoS and energy resources on that path. Consistency in the routing table between upstream and downstream SNs helps in achieving failure recovery for each path. Protocol suffers from the overhead of maintaining the tables and states at each SN, especially when the number of nodes is huge.

Energy-aware QoS routing protocol: Akkaya et. al proposed an approach that identifies the smallest cost energy-efficient route with end-to-end delay as criteria during connection [99].

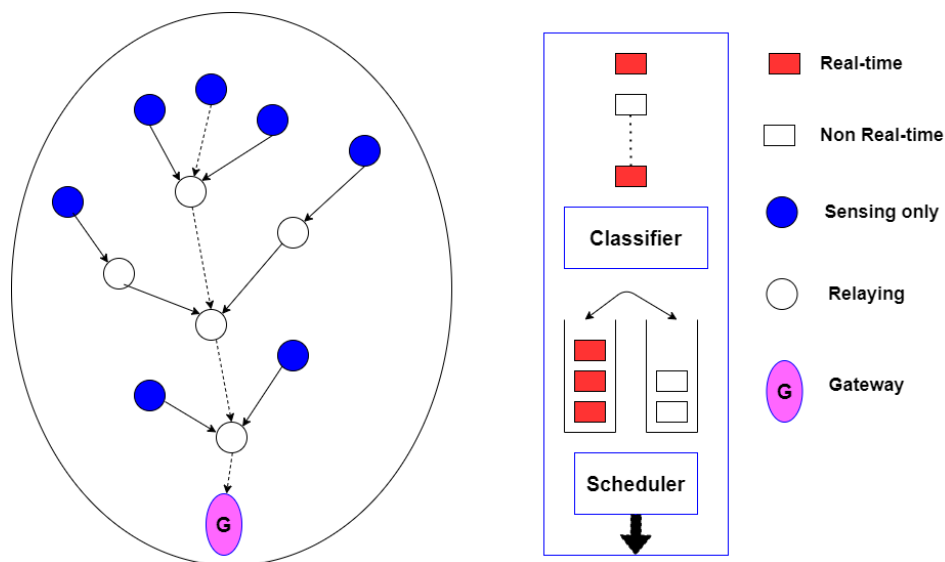

Fig. 2.8 Queuing model for a specific sensor node [99]

The SNs' communication energy, energy reserve, error rate, and other relevant attributes are used to define link cost. A class-oriented queuing model is utilized to support both best as well as real-time traffic simultaneously which allows service sharing during real-time as well as non-real-time traffic. The queuing model is redrawn from [99] and is depicted in Figure 2.8. The protocol uses an extended version of Dijkstra's algorithm discovers to find a path from that list that meets end-to-end delay requirements by a list of least-cost paths.

SPEED: Tian He et. al. proposed a QoS-based routing protocol with soft real-time endwise guarantees [100]. The approach needs each SN to preserve information regarding its neighbors and uses geographic forwarding to identify routes. Moreover, the protocol ensures a specific speed for each packet in the network so that the respective application may estimate endwise delay for the packets before making an entrance decision. Also, SPEED supports an overcrowding avoidance mechanism in case the network is overcrowded. At the network layer, the routing module of SPEED called Stateless Geographic Non-deterministic Forwarding (SNGF) works with four other modules, as depicted in Fig. 2.9, redrawn from [100]. The beacon exchange part gathers information about SNs and their position. Delay assessment at each SN is carried out by finding elapsed time after receiving the ACK from adjacent SN as a response to a communicated data packet. Through examination of delay values, elects SN, that meeting speed requirement. SPEED performs better than Dynamic Source Routing (DSR [101] and Ad hoc On-Demand Vector Routing (AODV) [102], on attributes of miss ratio and end-to-end delay. Furthermore, total communication energy is less because of the simplicity of routing algorithm.

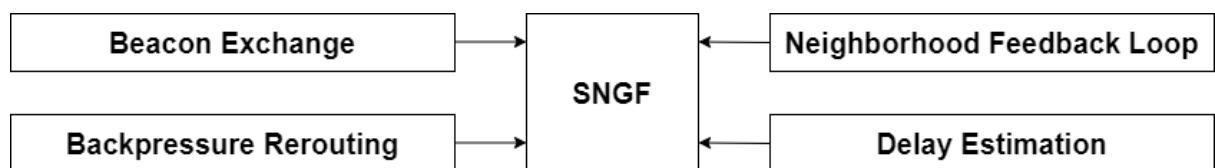

Fig. 2.9 Routing components of SPEED

2.3.4 Hierarchical Routing Protocols

The prime objective of hierarchical routing protocols (HRP) is to achieve energy efficiency by making groups of SNs to reduce communication among SNs and BS. Every group has a head that aggregates data to reduce the amount of data transferred to BS [103]. Several parameters for instance residual energy, or distance from BS may be considered for the

formulation of clusters and CH election. The distance among sensor nodes directly affects the energy consumption of a sensor node. Multi-hopping here emerges as a solution to conserve energy up to certain extents. Further, some applications use the dense deployment of sensors in an area of interest to get very similar values for the physical parameters being

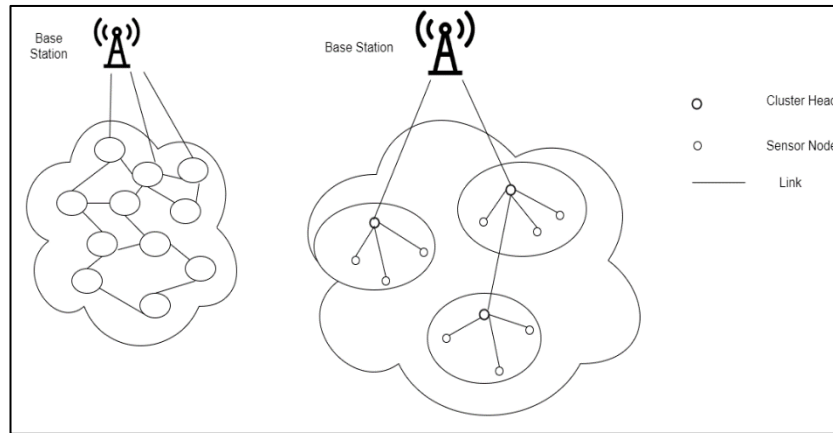

Fig. 2.10 Comparison of flat and clustered WSNs [38]

observed. WSNs may be connected with web services to retrieve and disseminate sensed data by densely deployed nodes, and approaches for clustering oriented web services selection scheme is given in [104]. The dense deployment may lead to excess multi-hopping; hence need a method of optimized clustering and CH selection. Figure 2.10 shows two types of WSN deployment, the flat WSN, and hierarchical WSN. In flat architecture, all the sensor nodes send data directly to the BS, and data transmission consumes the maximum energy for the sensor nodes that are comparatively farther from BS, leading to early drainage of energy and a decrease in overall WSN lifespan. A hierarchical WSN is better than a flat WSN as in a cluster of nodes, only one node, i.e., CH node, sends data to BS, thus conserving the energy of other sensor nodes.

Various clustering-based routing protocols such as Low Energy Adaptive Clustering Hierarchy (LEACH), Power-Efficient Gathering in Sensor Information Systems (PEGASIS), Hierarchical PEGASIS, Energy-aware routing for cluster-based sensor networks, Power-Efficient Adaptive Clustering Hierarchy (PEACH) exist in literature. Some of these protocols consider the health of nodes for CH selection [105]. Overhead of CH selection is a concern that needs to be taken care of in hierarchical protocols. Some of these hierarchical routing protocols are discussed in this section.

2.3.4.1 Chain Based Classical Hierarchical Routing Protocols

In this category of hierarchical routing approach, the whole WSN is alienated into several chains and a chain leader is selected for each chain [106]. Each SN delivers packets to the

next adjacent SN until it reaches the chain leader (*see* Figure 2.11). Data is aggregated and the leader node sends aggregated data to BS. These are comparatively easy to set up and preserve with not-so-frequent changes in a chain formation. SNs always send data to the closest node leading to low consumption of energy. The issue with this category of routing is that there might be numerous SNs in a chain, and in case, source SN is far away from the chain leader SN, data shall be required to move for a comparatively longer distance. Thus, the time used for the delivery is high and can cause delays, and is not appropriate to time-critical applications. Also, sensor nodes that are nearer to the chain leader SN shall always be involved in data communication creating a heavy burden on these SNs, leading to the higher energy consumption of these nodes. Moreover, in case of malfunction of SNs in the chain, all the data moving through failed SN and chain shall be lost raising doubts over the dependability of applications and performance of the chain. The most pertinent chain-based routing algorithms are discussed below:

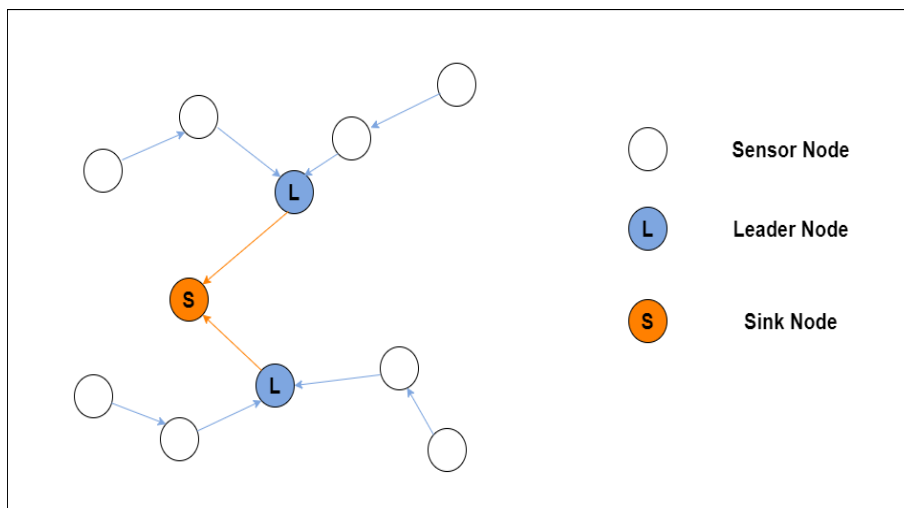

Fig. 2.11 Chain based hierarchical routing

Power-efficient Gathering in Sensor Information Systems (PEGASIS) [107] is proposed by Lindsey et.al., and is an enhancement of LEACH. It forms chains from SNs so that each SN communicates and receives from only one SN, selected from the chain to transmit to the BS. Collected data moves from SN to SN, aggregated, and finally sent to BS as shown in Figure 2.12. The alteration from LEACH is in the usage of multi-hopping and formation of chains and opting only one SN to transmit to BS rather than multiple nodes. PEGASIS outperforms LEACH by about 100–300% for different network topologies and magnitudes due to elimination of overhead in dynamic cluster formation for LEACH and decreasing amount of transmissions and reception using data aggregation

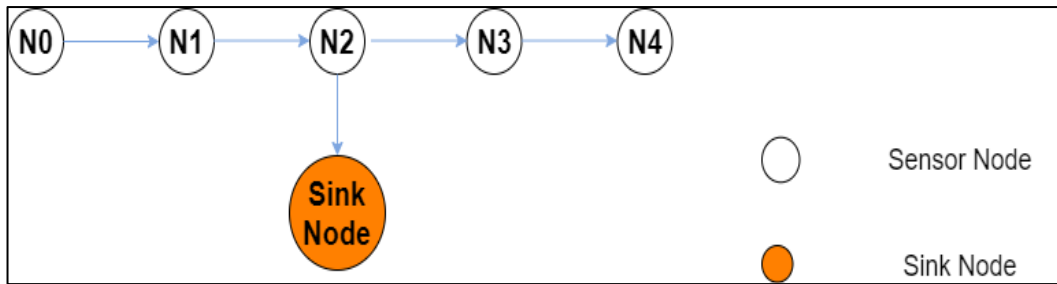

Fig. 2.12 Chain formation for PEGASIS [107]

Hierarchical-PEGASIS: Lindsey et.al., proposed an extension of PEGASIS, with the purpose of reducing delay sustained during communication with BS, and ponders energy-delay metric to propose an effective solution for data gathering concern [95]. In PEGASIS, the transmission of messages is carried out simultaneously. To evade collisions and potential interference in signals, between SNs, two methods have been examined. The first method includes signal coding, such as CDMA whereas in the second method, only spatially, detached SNs are allowed to transmit simultaneously. This protocol with CDMA enabled SNs, forms a chain of SNs making a tree hierarchy, where each selected SN at a specific level communicates data to SN at the upper level of hierarchy as shown in Figure 2.13. It ensures data communication in parallel and lessens the delay. A three-level hierarchy of SNs created in a non-CDMA approach. In it, carefully scheduling simultaneous transmissions, interference effects are reduced. Although it avoids clustering overhead as in the case of LEACH, yet it needs dynamic topology adjustment as the energy of SNs is not tracked.

PEGASIS with Improved Network Lifetime (PEGASIS-INL): Mishra et.al. proposed an improvement over PEGASIS with an effective chain formation arrangement for PEGASIS improving network lifetime [108]. It selects a subset of SNs near BS as candidate leaders. Details of candidate leaders are shared with all SNs using the multi-hop broadcast process. In each round, SNs send aggregated data to the chain leader SN, who sends it to BS. This approach elects an SN as a chain leader only if it is within a strong communication range of BS. Lower energy consumption in each round by each SN attributes to improve the lifetime of SN.

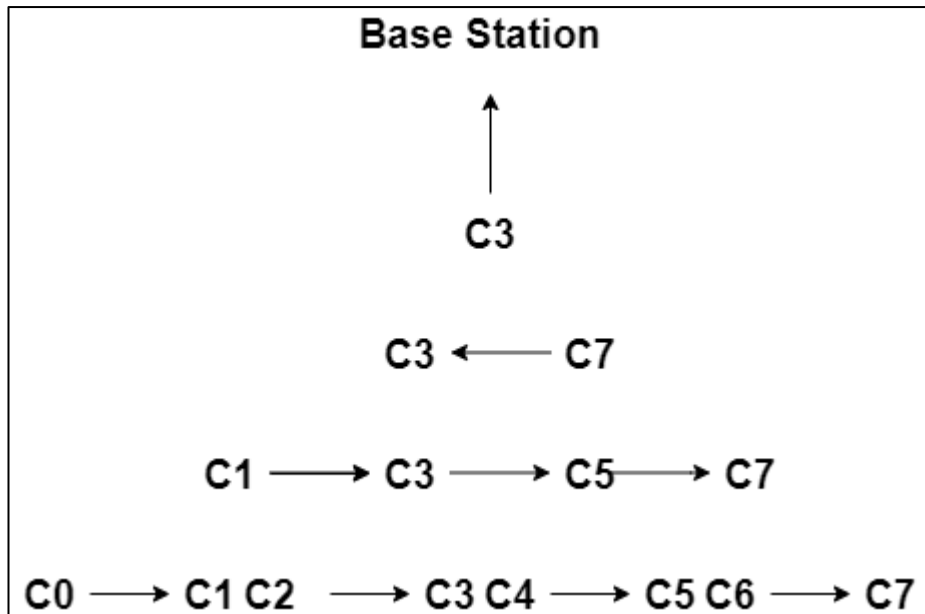

Fig. 2.13 Data gathering in a chain based binary scheme [109]

Modified PEGASIS: In this protocol, each SN communicates only with an adjacent SN at minimum distance, and transmits data to BS, thus reducing energy spent per round [110]. For this protocol, it will combine few parameters of Distance and Residual Energy for each node. In case, distance from the nearest SN to the SN upstream of it is more than the other node's distance, then it is known as the Far node and the nearest node shall not consider that node as a member of the chain. In case, the nearest node having modest energy joins the chain, it shall arise as a long chain.

Concentric clustering scheme (CCS): CCS is built with multiple chains. Multiple chains are alienated into different layers with a CH for each chain [111]. All SNs, within the chain, send data to the nearest SN till data reaches CH. Subsequently, CH on the most distant chain sends data to a CH on succeeding higher layer till it reaches BS. In comparison to PEGASIS, distance covered can be condensed greatly as data is communicated among CHs up to BS. So, the delay is lesser and thus is more appropriate for large-scale WSNs, though CH on-chain contiguous to the BS will have to bear substantial traffic and may get fatigued sooner as compared to others. Also, the residual energy of SN is not taken into consideration while selecting CH. Thus, an SN with low residual energy may be chosen and get exhausted comparatively quickly.

Energy-balanced chain-cluster routing protocol (EBCRP): Bao Xi-rong et.al. proposed a protocol in which the whole WSN is alienated into several rectangular sections, with a chain being established in each rectangular area using a ladder algorithm [112]. CHs are

designated according to their residual energy and are rotated for balancing the load. CH of every chain accumulates data from all SNs in its chain and sends it to BS directly. This approach is comparatively energy-efficient than the greedy algorithm, as the overall transmission distance is shorter. However, neighbouring SNs within a rectangular section might not be on the shortest distance path and hence may consume more energy. Also, the approach may not be suitable for large scale WSNs due to the provision of single-hop communication.

Chain-based hierarchical routing protocol (CHIRON): Kuong-Ho Chen et. al. proposed a protocol that splits whole WSN into flexible fan-shaped areas. Most distant SN from BS starts chain formation [113] and then joins the nearest SN to build a chain applying a greedy algorithm. A chain leader is chosen for each chain as per its residual energy and SN with maximum residual energy turns into the chain leader. It then collects data from its chain members, communicates collected data to the next chain leader, and finally to BS. As the approach supports multiple hop communications, it is appropriate for large WSNs. The approach can curtail communication distance and decrease the delay in data transmission.

2.3.4.2 Hierarchical tree-based routing algorithms

In this category of hierarchical routing, SNs are separated into multiple branches, leaf, and parent nodes [114]. Data is communicated from the leaf node to its parent, further to the next parent node till it reaches BS (*see* Figure 2.14). This kind of topology is easy to create with each SN required to communicate data to the next higher-level SN that is nearer to BS. Explicit cluster formation, in this case, is not required leading to a possible reduction in energy consumption. The downside of a tree topology is that in the case the parent node of a tree is not available to perform its intended functions, and then all the data communication under its branch shall be lost. Moreover, parent nodes closer to BS or having many branches shall consume more energy due to the high data volume it handles.

Energy-aware data aggregation tree (EADAT): In this approach, BS starts tree formation [115] with each SN setting a timer to start the communication, and a wait time related to its remaining energy. Higher residual energy leads to a shorter wait time. Then, SN with higher residual energy and nearness to SNs gets elected as its parent. When the remaining energy of a parent SN is lower than a certain value, it shall broadcast a message to inform its child. The child may then elect another parent SN for transmission. As the remaining energy of SN is considered in selecting connection node and path, the chance of electing a fatigued

SN shall be reduced and transmission failure may be prohibited. Besides, by using the SN with higher energy first, load balancing can be achieved enhancing the lifespan of the whole network.

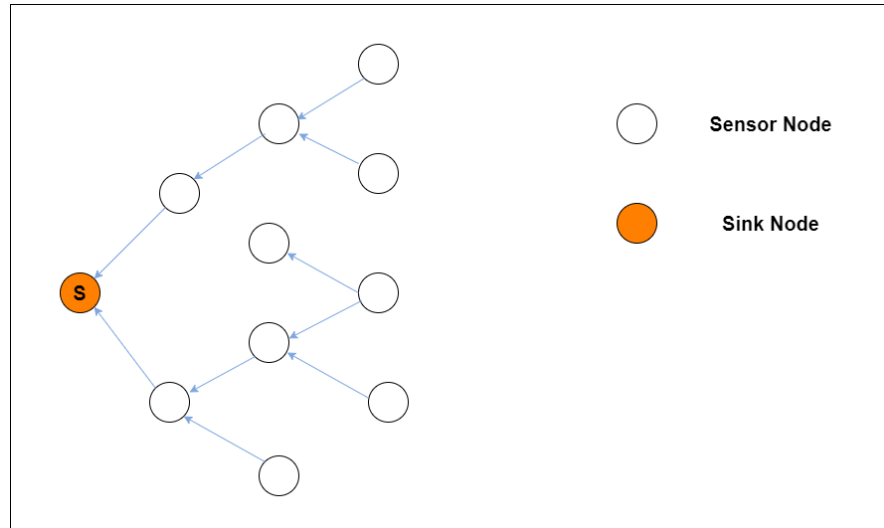

Fig. 2.14 Tree based Hierarchical routing protocols

Balanced aggregation tree routing (BATR): In this technique, BS collects global position information of all SNs and creates routes [116]. It forms a minimum spanning tree according to the energy being utilized and shall compute some children SNs under the tree to balance the load. The approach considers energy consumption to build the route and can extend the lifespan of WSN. Also, load balancing is achieved by evenly distributing children SNs among different trees, though the remaining energy of every SN is not taken into consideration while creating trees leading to some SNs with low remaining energy dying sooner, and trigger transmission failure.

Self-organizing protocol (SOP): Subramanian et. al. proposed SOP Self-Organizing Protocol comprises four phases viz. Discovery, Organization, Maintenance, and Self reorganizing [117]. In the discovery phase, the entire sensor node's neighbour is explored. During the organization, clusters are formed and joined hierarchically where each SN is given an address according to the position of SN in the hierarchy. On creation of routing table of size $O(\log N)$, broadcast trees are prepared. During the stage of maintenance, tables of routing and energy levels of SNs are updated and transmitted by SNs to respective neighbouring nodes. Finally in the self-reorganization phase groups are reorganized in case of partition or node failures.

Power-efficient data gathering and aggregation protocol (PEDAP): Huseyin et. al. proposed PEDAP which applies Minimum Spanning Tree (MST) for calculating energy utilization [118] To build the tree data volume and transmission distance are used. Besides, the remaining energy of SNs is considered in data communications. PEDAP balances energy use and curtails delay with the construction of an MST keeping energy, distance cost into consideration for transmission. Though the creation of a tree may be complex, and energy utilized to identify routes may be high making it impractical for large WSNs.

Enhanced tree routing (ETR): Qiu et.al. proposed an approach in which every SN preserves a routing table with next-hop information [119]. SN shall choose a route with the smallest hop count. As the routing table stores only next-hop details, storage, and processing cost are relatively less and helps to save energy. But residual energy is not considered to select the path as it is elected as per minimum hop count. Hence, a path with low remaining energy may be selected, and may fully utilize soon, so SNs may die and data may have vanished.

2.3.4.3 Hierarchical Grid-Based Routing Algorithms

In this category of algorithms, the entire area of WSN is bifurcated into numerous grids, and a leader is elected for every grid [120].

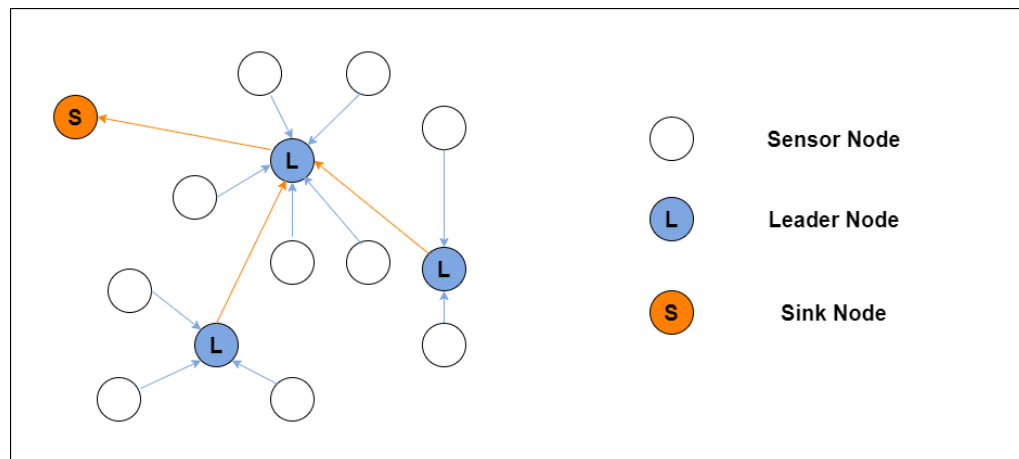

Fig. 2.15 Hierarchical Grid-based routing

Within the grid, all SNs shall transmit data to the respective leader, and this leader shall communicate data to the next grid's leader and this process is followed until data reaches BS (see Figure 2.15). The structure of grid-oriented routing is simple and is based on the geographical placement of SNs. Data transmission is the more efficient size of the grid is static, and only information regarding the position of grid leader is required. Presence of

high number of SNs in a potentially leads to substantial traffic and can exhaust leader SN's energy.

Position-based aggregator node election protocol (PANEL): Butty'an et.al. proposed PANEL, an approach that utilizes information of position to elect CH [121]. The whole WSN is divided geographically, and SN nearest to the reference point is chosen as an aggregator. This aggregator SN accumulates data from members of its cluster and communicates it to BS. As every SN has the chance to become an aggregator, load balancing can be achieved because of sharing the load of communicating with BS though little bit energy shall still be consumed for amassing location of SNs, that increases setup cost.

Two-tier data dissemination (TTDD): Haiyun Luo et.al. proposed TTDD in which a grid is bifurcated into several cells, and some of SNs are used to relay requested data from the mobile sinks (MS) to the source [122]. Mobile sink shall communicate data requests to intermediate SNs by using the flooding approach. After this source elects the next relay nodes with a greedy algorithm until data arrives at the boundary of WSN. Respective MS move around grids and retrieve data from nearest SN to source. TTDD is more appropriate for on-demand applications. Flooding may lead to higher energy consumption, and thus is not appropriate for large-scale, heavy traffic WSNs. Also, the movement of MSs may not be at the same velocity as the route created.

Hierarchical geographic multicast routing (HGMR): HGMR proposed by Koutsonikolas et. al. divides the entire WSN into numerous cells according to their respective geographical position [123]. For managing location information, there is a provision for an access point within each cell. WSN is structured in a hierarchical manner with sources delivering data from highest to lowest access points. Because accessing points can be rotated, different SNs shall take relevant roles in data communications helping in balancing energy consumption. As WSN is bifurcated into many cells and layers, this approach is appropriate for large scale WSNs but because communication from higher to lower access points does not keep into consideration the location, the route might not be shortest causing time delay thus consuming extra energy.

Grid-based multipath with congestion avoidance routing (GMCAR): Banimelhem et.al. proposed (GMCAR) an approach that divided WSN into grids with one leader SN in every grid. Leader SN collects information from grid members and communicates the same to

leaders in other grids [124]. Every leader stores a routing table, consisting of information about grid density and hop count. The approach separates heavy and low traffic providing only a single route to sink in boundary grid for low traffic. The routes with heavy traffic, multiple paths to BS with non-boundary grids are created. Besides, a subordinate leader SN is also elected to share high traffic if required. Leader SN is responsible for coordination till its energy slopes to a specific level.

Wang et. al, proposed A novel energy aware hierarchical cluster-based (NEAHC) routing protocol with two goals of minimizing the total energy consumption and ensuring fairness of energy consumption between nodes. They modelled relay node choosing problem as a nonlinear programming problem [125]

2.3.4.4 Hierarchical area-based routing algorithms

The whole WSN is bifurcated into many areas, and the dimensions of each area may vary. BS sends a data request to the nearest SNs in a designated area to gather data (*see* Figure 2.16). Flooding of data requests is performed till the source of data is found. Source SN then sends data to the sink which is appropriate for applications in which the mobile sink is always traveling within the specific area. Some of the area-based routing algorithms are discussed below:

Line-based data dissemination (LBDD): Hamida et.al. proposed (LBDD), an area-based routing approach. The entire WSN is configured into two identical areas with a vertical line of SNs [126]. Sensor nodes on the vertical line accumulate data to serve requests from BS. All SNs recognize each other's position information. Source SNs send data to the nearest SN on the designated line. BS sends a data request to the line in a perpendicular fashion. SN getting request message shall process it and relay request further to other SNs on the lines in both directions. Lastly, the node storing data receives a request and communicates data to BS, directly. Although setup and communication of WSN organization are simple in case, lesser number of SNs are present on the line, SNs may get heavily burdened and get exhausted swiftly.

Ring routing: Can Tunca et. al. propose an approach that supports a kind of ring topology [127]. Its working is identical to LBDD [126] but, instead of a line, a ring is designed which is comparatively simple to form. Relay SNs of the ring may be exchanged with normal SNs. It works to balance load among SNs as relay SNs on the ring are rotated to prevent any SN

from getting overloaded. By utilizing this approach, source SN can discover the nearest relay SN in a short distance, reduces delay, and consumes less energy during data transmissions. However, setup costs of ring structure can be enormous as data requests are transmitted to all involved SNs on the ring causing overhead.

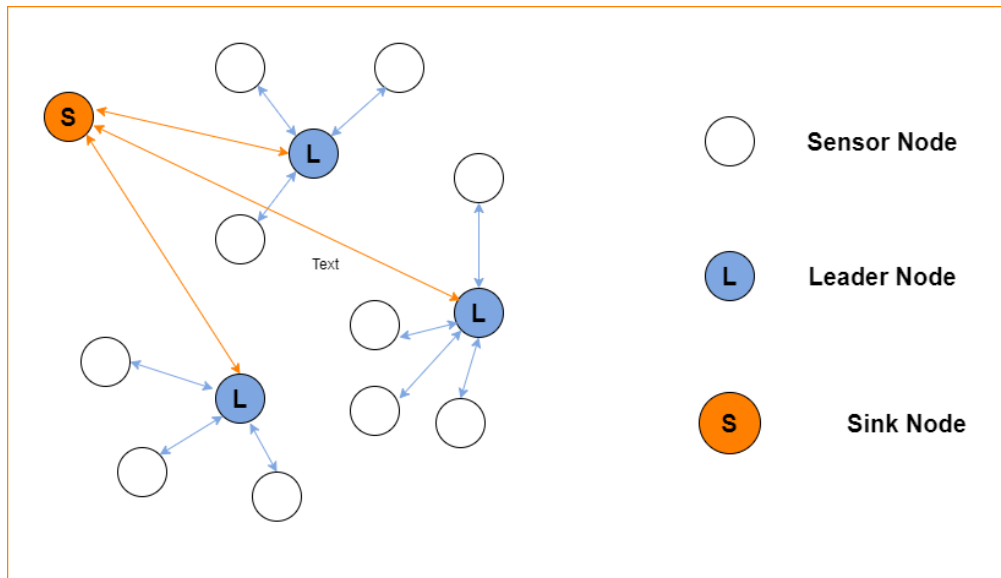

Fig. 2.16 Hierarchical Area-based routing

Railroad: Shin et.al. proposed a data diffusion architecture called Railroad for large-scale WSNs [128]. WSN is bifurcated by one rail that manages data requests. Rail is placed in the central part of WSN for ease of access to all SNs. The data request is communicated to the rail until it arrives source node, it shall send data directly to BS. Data request from BS is in unicast fashion. Rail is a comparatively flexible structure than a line or ring structure, with relay SNs on the rail being accessible to normal nodes easily, that curtail time and distance for source SN to transmit.

Virtual Line-based data dissemination (VLDD) Mo et. al. proposed the VLDD approach, which is Virtual Line Structure (VLS) for data storage which is used to accumulate data from a source [129]. A source node identifies position information of mobile sinks and calculates an appropriate entry point on the rail. Relay SN on rail sends data to neighbouring SNs on the rail. After this mobile sink sends a data request to VLS to acquire data. The virtual line gets recreated as per the location of mobile sinks which is different from flooding-oriented communications. SNs calculate appropriate entry points to

communicate evading redundant deliveries and hence diminishing energy consumption and decreasing delivery time. But like other area-based routing approaches, VLS suffers from higher overhead and communication delays for large WSNs.

2.3.4.5 Block Cluster Based Hierarchical Routing Protocols

These types of protocols divide WSN into groups called clusters with each group having a head called CH which gathers and aggregates the data of SNs in its group and communicates aggregated data to BS. A major concern with these protocols is CH selection and the limited range of SNs that can directly connect with BS [130].

Low Energy Adaptive Clustering Hierarchy (LEACH) and variant: This communication approach utilizes the concept of a grouping of wireless sensor nodes [131]. One of the major contributions of LEACH is the random rotation of cluster heads so that no single SN that has been chosen as CH is put under stress because CH nodes presumably consume more energy as they are involved in potentially long-distance communication with the base station. In addition to this local data aggregation also helps diminish the amount of data to be communicated, thus allowing for energy conservation. LEACH is partitioned into two phases called steady and setup phase. In the setup phase in LEACH, sensor nodes arrange themselves in a cluster with one of them acting as CH. One of these sensor nodes from the cluster elects itself as CH taking into consideration the predetermined CH percentage of the network and the total number of times the SN is being selected as CH up to now. The SN chooses any arbitrary value between 0 and 1. If this arbitrary value is lesser than a given threshold as given in Eq. 2.1, this sensor node turns out to be CH for the present pass. The threshold is given through equation as below:

$$T(n) = \begin{cases} \frac{P}{1 - P * (r \bmod \left(\frac{1}{P}\right))}, & \text{if } n \in G \\ 0 & \text{otherwise} \end{cases} \quad (2.1)$$

Here, P is requisite proportion of CH sensor nodes, r is the present iteration number and G represents collection of SNs which have not become CH in previous $1/P$ rounds which implies that in next $1/P$ rounds every node shall have an opportunity to be a CH. This rotation for the role of CH helps in precious energy conservation. All the elected Cluster Heads broadcast their announcement advertising themselves as CH to non-CH nodes using CSMA MAC and same energy levels.

A-LEACH, an improvement of LEACH protocol was proposed by Ali et al. It utilizes initial and existing energy of SNs to calculate energy factor [132] and deliberates on the most appropriate number of clusters among the overall number of clusters to select CH. Leach-B is proposed by Tong and Tong and sustains a requisite percentage of CHs [133]. The CHs are selected randomly in the first round. Subsequently, SNs with smaller time intervals shall have higher priority to become a CH, in case, the number of clusters is less than the desired percentage. Time interval is inversely proportional to the SNs' remaining energy which means that SNs with the highest remaining energy will be CHs. In case, the total number of clusters is more than desired, CHs with the least remaining energy shall be treated as normal nodes.

Mehta et al. considered balancing of clusters' size that is distributed uniformly across whole WSN in C-LEACH [134]. The approach considers the minimum and maximum number of SNs in each cluster by introducing a threshold value for them. Besides, the current and initial energy of SNs is also considered in this approach. Tripathi et al. proposed LEACH-CE [135]. According to this approach, SNs with more than the nodes' average energy is chosen as CH but it does not imply highest energy means that CHs may still get exhausted quickly if their energy was just a little higher than average. Thus, to balance energy usage of SNs, LEACH-CE proposes to select SNs with maximum remaining energy in that group of SNs as final CH. Deterministic Cluster-Head Selection (DCHS) was proposed by Handy et.al. in [136]. It selects CH not only according to current and maximum energy but also considering the quantity of rounds that an SN has not been a CH.

E-LEACH [137] proposed by Xu et.al. considers the existing and original energy of SNs. While computing the probability of a CH, distance to BS and covered area are taken into account. Hybrid LEACH (HLEACH) is proposed by Azim and Islam which calculates variation between existing and original energy of SNs. It applies clusters' count and the overall number of SNs for ascertaining the selection of CHs [138]. I-LEACH is proposed by Beiranvand et. al. gives considerations to distance from BS, remaining energy, and the number of adjacent SNs while electing a CH [139]. N-LEACH is given by Li et al. [140] that uses the present and opening energy for calculation, though, it uses its own ascertained probability to elect CHs instead of considering CHs' count and the total number of SNs.

P-LEACH proposed by Jin et.al. takes the average energy of all SNs into account. [141] comparing the existing energy of an SN with all SNs' average energy. In case, an SN has higher positive residual energy in comparison to average energy, it receives higher importance for election as a CH. Quadrature LEACH [142] is proposed by Manzoor et.al.

where each SN transmits its position information to BS. It segments the whole WSN into four equivalent regions as per location of SNs. Few CHs are selected in each quadrant to synchronize data transmissions of CM SNs that helps in balancing the load of CHs achieving improved coverage.

LEACH-SWDN is proposed by Wang et.al., that employs the remaining energy of SNs to elect CHs [143] to maintain a steady number of CHs, A sliding window control is utilized for CH selection criteria. LEACH-SWDN elects CH dynamically consistent with a number of alive SNs. Moreover, preliminary energy of SNs, and the alive SNs' average energy that has not been CH for that specific cycle are considered.

T-LEACH was proposed by Hou et.al. for computing the probability of becoming CH [144]. The protocol utilizes the total energy of all SNs, instead of the initial energy of each SN and distance among member SNs within its cluster into deliberation, as well as SNs' count and CHs' count. U-LEACH proposed by Ren et.al. which divides WSN into concentric circles, and clusters that are at a higher distance from BS should have a shorter size of the cluster. On the contrary, the size of the cluster increases as clusters come closer to BS. Distance, remaining energy, and weight parameters are also taken into account while electing a CH to reduce hotspots.

Ahmed Al-Baz et. al. Node Ranked LEACH (NR-LEACH) [145] protocol is a significant improvement over LEACH and its variations. The authors also discuss an enhancement of LEACH called improved LEACH [146]. The protocol tries to distribute energy load on sensor nodes in an optimized way by using its NRA, (Node Ranked Algorithm) for the selection of cluster head. The algorithm overcomes the scalability issue of LEACH protocol because an uneven spreading of sensor nodes to a CH leads to a situation where on one hand there is a CH who is managing a great number of sensor nodes and on the other hand another CH is handling very few sensor nodes. The CH managing a high number of sensor nodes shall be receiving data from more nodes, consuming more energy, and thus shall have a shorter lifespan leading to the need of selecting a new cluster head which again would be an overhead affecting the overall network lifetime. The protocol is bifurcated into two stages called setup and steady respectively. In the setup phase cluster establishment and selection of CH take place. CH is selected by using node rank algorithm which uses three parameters of residual energy of sensors nodes; their position found using received signal strength and number of link connections with other sensor nodes to find relative importance i.e., to calculate the rank of nodes.

Power-efficient and adaptive clustering hierarchy PEACH protocol [147] is a hierarchical protocol for WSNs. A SN can recognize the source and the target of packets sent by neighbor SNs, by overhearing them. As per overheard signals, the approach creates clusters without much packet transmission overhead of messages for advertisement, announcement, joining, and scheduling. PEACH functions with probabilistic routing protocols, to provide multilevel clustering making PEACH more scalable and efficient.

Another protocol called Hybrid, Energy-Efficient, Distributed (HEED) [148] proposed by Younis et.al. is a distributed, energy-efficient hierarchical approach for ad-hoc sensor networks. This being a hybrid protocol, CHs are elected probabilistically as per their remaining energy and nodes join clusters in a fashion to minimize communication cost. The approach assumes quasi-stationary networks with location-unaware nodes having the same importance. HEED exploits the availability of multiple transmission power levels at SNs. Its attributes, like minimum selection probability and network operation interval, can easily be adjusted to optimize the usage of a resource based on network density and application requirements.

Manjeshwar et.al. proposed Threshold sensitive Energy Efficient sensor Network (TEEN) protocol [149] that intends to respond to sudden changes in attributes monitored by SNs and is more suitable for time-critical applications. The protocol applies a hierarchical network structure wherein SNs closer to each other form clusters and utilizes a data-centered approach. Figure 2.17 redrawn from [149] presents the hierarchical clustering of TEEN. CH broadcasts hard along with soft threshold values after cluster formation for sensed attributes. The hard threshold is the smallest value of an attribute triggering SNs to wake up to communicate sensed attribute to CH thus decreasing data transmission by allowing SNs to transmit only when the value of the sensed attribute is inside the necessary range of values. After detecting value for an attribute that is on a threshold or outside hard threshold value, SN transmits this data to CH only when the value of the parameter varies by a value equal to or more than the soft threshold value leading to a reduction in the number of transmissions. TEEN is not pertinent for applications demanding episodic communication of data as in case thresholds are not reached, the user might not obtain any data. An enhancement of TEEN was proposed by authors as APTEEN [150].

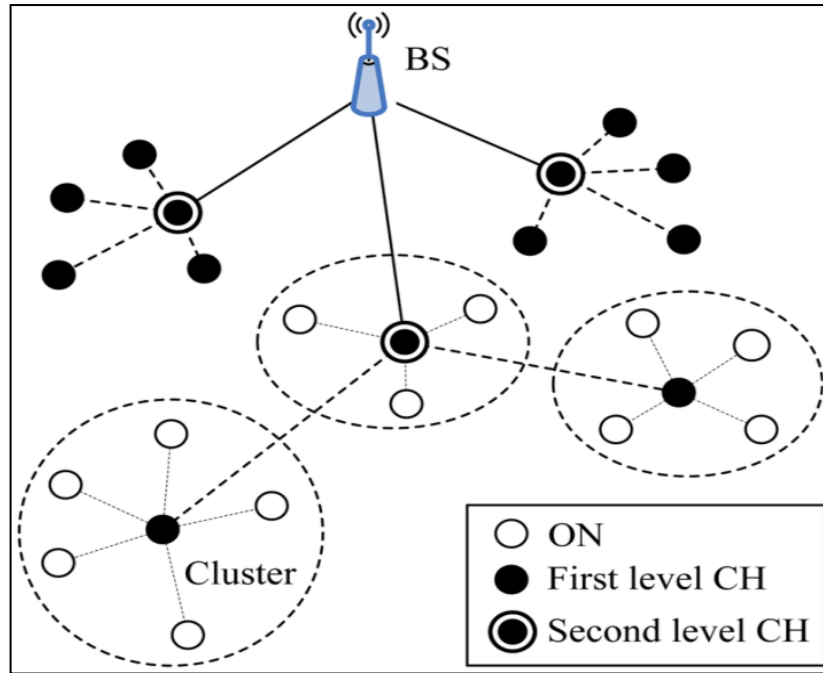

Fig. 2.17 Hierarchical routing in TEEN [149]

A hierarchical routing algorithm was proposed by Younis et.al. with three-tier architecture [151] SNs are gathered into clusters preceding the network process. Algorithm engages CHs, called gateway that is less energy-constrained than other SNs and know the position of these SNs. These gateways preserve states of SNs and create multi-hop paths to collect data. TDMA oriented MAC is used for SNs to transmit data to the gateway with a gateway informing each SN the span in which it can listen to the transmission of other SNs and the slots that may be utilized by a SN for its communication. BS communicates only with the gateways and SNs in a cluster can be in states of sensing, relaying only, sensing inactive, and relaying. In the sensing state, SN probes the environment and generates data at a persistent rate. In relaying state, SN does not sense the target but its communications circuit is turned on to relay data from other active nodes. In case, a node is both sensing as well as relaying messages from other SNs, it is considered to be in the state of sensing relaying. Otherwise, the node is considered to be in an inactive state and is allowed to turn off its sensing and communication circuit. A cost function concerning delay, energy consumption, optimization, and other performance parameters is defined between any two SNs. By utilizing this cost function as link cost, the least-cost path is found between SNs and the gateway. The gateway continuously monitors the available energy level at every SN that is active for data processing, sensing, or forwarding and relaying data packets.

2.4 Optimization Based Routing Protocols for WSNs

With the expansion of computational intelligence (CI), intelligent algorithms-oriented routing approaches like ant colony optimization (ACO), genetic algorithm (GA), fuzzy logic (FL), and neural networks (NNs) are becoming prevalent for improving the performance of WSNs routing. They facilitate intelligent performance in complex, changing environments that may be utilized to design distributed real-time algorithms. Optimization approaches have been proved to work well under WSN-specific requirements like changing topologies, communication failures, and mobility. These intelligent approaches have various properties, and they need to be applied according to specific application setup. Genetic Algorithm (GA) and Neural Networks (NN) have high computational needs and are normally centralized solutions. They are slightly better suitable for clustering when the clustering can be pre-deployed. Fuzzy Logic (FL) is appropriate for implementing routing and clustering heuristics like the link or CH quality classification. However, FL produces non-optimal solutions and topology changes demand relearning of fuzzy rules.

2.4.1 Fuzzy Logic Based Routing Protocols

Fuzzy logic is a mathematical approach for presenting approximate human reasoning. Different from the classical set theory which allows elements to be either part of a set or not, FL establishes in-between values according to inference rules and linguistic variables. In a fuzzy set, an element can have partial membership in the range [0,1]. FL utilizes linguistic variables whose values are words or sentences in artificial or natural language, and inference rules are applied to govern estimated reasoning. An expert may form inference rules by using words akin 'more', 'few', 'many' and connectors such as 'AND', 'OR', 'NOT' along with linguistic variables.

Gupta et.al. proposed a fuzzy logic approach called FCH [152] for CH election for WSNs. In this approach, CHs are elected by BS in each round with consideration for energy, centrality, and concentration as three linguistic variables for determining the chance to become CH. Node concentration defines SNs' count in its vicinity whereas SN centrality is defined as a value that categorizes SNs according to how much central SN is in the cluster. Linguistic variables', SN energy as well as density of SNs are divided into low, medium, and high levels whereas centrality are bifurcated into three different close, adequate and far levels. The consequence to present SN, CH election chance is divided into very small,

small, rather small, medium, rather large, large, and very large as defined levels. Moreover, triangle membership functions are applied to provide medium and adequate fuzzy sets, whereas, trapezoid membership functions are used to represent sets of low, high, close, and far fuzzy types. Working of this fuzzy CH election approach is bifurcated in rounds comprising of setup and steady phases. All SNs in the setup phase are analyzed according to chances and SN with the highest chance is chosen as CH. If there are several SNs with the highest chance, then the SN with higher energy is chosen. Each SN in the cluster associates itself to a CH and starts sending data. The data transmission phase of FCH is identical to LEACH's steady-state phase. FCH rotates CH according to the de-fuzzified chance value and considers parameters such as centrality, energy, and concentration to determine the chance.

Minhas et.al. proposed a Fuzzy multi-objective routing algorithm (FMO) [153]. This approach optimizes two routing purposes for WSNs simultaneously. FMO applies fuzzy membership functions and rules for designing cost functions. A static WSN deployment is represented as a directed graph $G(V, E)$, where V represents a set of SNs and E gives a set of links. On the origin of routing requests, a fuzzy lifetime membership, as well as a fuzzy minimum energy membership, is calculated for every edge after which, corresponding multi-objective membership is computed. On getting multi-objective membership, every edge is given a weight. Following weight assignment, a multi-objective path is identified with the help of Dijkstra's shortest path algorithm. Because of its characteristic FMO can be used to attain multiple routing objectives simultaneously.

2.4.2 Neural Networks-Based Routing Protocols

Neural networks (NNs) are models of biological neural systems [154]. The brain of a human encompasses a great number of neurons with each neuron linked to numerous other neurons receiving signals through synapses. An important role is played by these synaptic connections brain's behavior. This structure appears identical to a dense network. A NN comprises a network of neurons, systematized in various layers called input, output, and hidden layer.

Barbancho et al. proposed Sensor intelligence routing (SIR), a QoS-oriented routing approach with the purpose of automatic reading of public utility meters [155]. A NN is embedded in each SN for managing to route. Here, the first layer has 4 neurons and the second layer has 12 neurons in a 3x4 matrix. Inputs include duty-cycle, throughput, error

rate, and latency. Samples presented as inputs make groups so as all samples in a group have identical features. A map is molded by clusters, where each cluster corresponds to specific QoS and is given a neuron of the output layer. Once SN has gathered a set of input samples, winning neuron election algorithm is executed. After selecting the winning neuron, SN applies the output function to provide an estimation of QoS. In this fashion, each SN pings its adjacent SNs to find link quality. After this minimum cost paths from BS to every SN may be found by modifications over the Dijkstra algorithm. Bhagat et. al. proposed NHAP-RZLEACH-Based Hybrid Framework that uses Hopfield based NN approach to enhance WSN lifespan [156].

2.4.3 Metaheuristics-Based Routing Protocols

The Metaheuristic routing protocols for WSNs are classified among Evolutionary, Swarm-intelligence, and Bio-inspired routing protocols. Figure 2.19 shows some of the basic metaheuristic approaches used in WSNs.

2.4.3.1 Evolutionary Genetic Algorithm-Based Routing

Genetic algorithm (GA) produces many fruitful results in the engineering field. It is a structured, still randomized search technique that primarily works according to three genetic operators namely selection, crossover, and mutation. Figure 2.18 shows a category of optimization techniques.

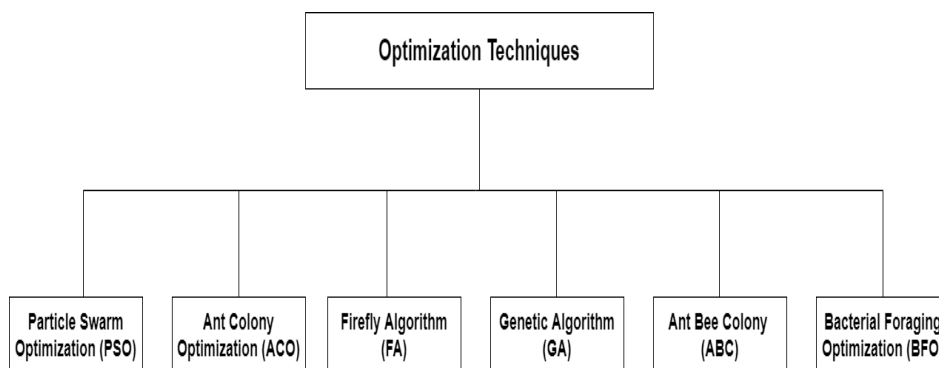

Fig. 2.18 Optimization Techniques in WSN

There are several selection approaches such as Roulette wheel, steady-state, rank, and elitism. As per application requirements, any of these selection techniques may be applied. In the crossover, two-parent chromosomes are selected and exchange some of their genetic information with each other for producing next-generation chromosomes. After this, mutation can be applied on chromosomes, which helps to avert GA from premature

convergence. It searches solutions from entirely new places rather than searching for the existing better solutions.

Baranidharan et.al. proposed a Genetic Algorithm Based Energy Efficient Clustering Hierarchy (GAECH) [157] in which fitness function is enhanced with such parameters included in fitness function that are intended to create balanced clusters and diminish overall energy consumption. Fitness function comprises of four main components of total energy consumption in one round, Standard Deviation (SD) in energy utilization among clusters, CH dispersal, and CH's energy utilization. For cluster formation, this approach runs centralized BS that has all the location details of SNs in the WSN. Genetic operators are utilized over a random initial population till arriving at termination condition. Latterly, the best-fit chromosome of the population signifies new cluster architecture. During data collection, CH nodes generate the TDMA schedule for their cluster members. Member node communicates its data to respective CH only in its allocated time. During other slots, it can go to the sleep state, however, CH SNs shall always be in a wakeup state so that they can accept data from their members.

Yuan et. al. presented a dynamic clustering approach, called a Genetic Algorithm-Based, Dynamic Clustering Method Towards Improved WSN Longevity GASONEC [158] for dynamic optimization of clusters. As per residual energy, locality, distance from BS, and expected energy utilization of SNs, an optimum dynamic WSN structure is constructed. For every cluster, any SN which has balanced all these aspects is declared as CH. In case, sensor field is far from BS, more clusters are formed to maintain high energy levels for improvement of the lifespan of WSN. Roopali et. al. proposed a network lifetime enhancing genetic algorithm-based cluster head selection and routing protocol specifically for wireless body area networks [159]. The proposed approach concentrates on inter-body area network communication and defines a cost function for ideal distribution in a cluster thus decreasing energy consumption.

One of the major challenges in WSNs is to attain good area coverage with the least SNs while conserving energy and resources consumption. Jia et.al. addressed this problem through Multi-Objective Genetic Algorithms (MOGA) [160]. The approach provides a method to cover the maximum deployed area with the least number of SNs. As coverage and connectivity are interrelated with each other, the problem is addressed by MOGA by realizing the Pareto optimal front presented as a non-dominated problem, which consists of multiple individual solutions evaluated against two fitness functions based on sensor used

rate and coverage area. Applied approach, MOGA performs well in a maximizing area covered with least energy computation.

Hussain et.al. proposed a Genetic-Algorithm approach for centralized hierarchical WSNs [161]. Their proposed approach consists of a hierarchy of layers with a sink at the top layer and CHs and SNs being at the bottom layer. GAs are applied to form clusters with CHs and other SNs. The sink layer keeps track of the whole cluster through their CHs. GA approach applied, minimizes average cluster distances while simultaneously, improving total transmissions' count. The data communication phase follows after configuring SNs in an optimized manner.

Yang. Xin et.al. proposed a new optimization algorithm, Firefly Algorithm (FA) that is based on the process through which real-life flies are attracted towards each other according to flashlight [162]. A unique pattern based on species of fireflies is generated by a flash of fireflies. The approach has an attraction, mating patterns, and prey as functions. A distinguish flashing sequence is utilized by female fireflies during mating for replying to males. Distance between two fireflies is inversely proportional to the amount of emission of light from female fireflies. This behavior is utilized in the firefly algorithm fireflies represent randomly produced solutions brightness represents the performance of the fitness function. Lalwani et. al. proposed an FA-based WSN routing algorithm that utilizes energy, SN distance, and remaining energy for its fitness function for route discovery from CH to BS [163]. Manshahi et. al. in their work applies FA to decrease fitness function with an increase in hop count and proposed a fitness function that makes use of remaining energy [164] and compared their approach with PSO. Yogarajan, et.al. considered a mobile sink called Mobile Data Transport (MDT) [165]. MDT visits each SN to accumulate data from every SN and forwards collected data to BS.

2.4.3.2 Swarm-Intelligence based Routing Protocols

Swarm intelligence (SI) is a comparatively novel field [166] that characterizes an attempt to design algorithms or distributed problem-solving devices inspired by the collective behavior of social insects and other animal societies [167]. In general, SI is the study of collective behavior of multi-component systems which synchronize decentralized controls and self-organization. Leading to scalable, adaptive, and robust behavior. Swarm-Intelligence based routing has been utilized in various types of Ad Hoc networks. Albayank et. al. proposed one such protocol for wireless Ad Hoc networks. The authors proposed

Bee-MANET, a warm-based routing approach to improve network throughput [168], and compared their protocol with AODV and Bee ad hoc protocols. The SI frameworks incorporate other widespread frameworks for instance Ant Colony Optimization (ACO) [169] and Particle Swarm Optimization (PSO) [170]. Literature in the field of SI is primarily stimulated by cooperative behaviors of natural systems, for instance, societies of insects like ACO, flocks of birds, say PSO, and schools of fishes. Elementary mechanisms of these biological arrangements have been reverse engineered and adapted appropriately to develop innovative algorithms for optimization and control. Similar processes have led to the development of many SI-oriented routing approaches for WSNs. The design of maximum of these approaches has been stimulated by foraging behaviors of ant colonies, and, bee colonies. As it has been observed that these insect colonies, do solve routing problems as a collective unit, gives impetus to the need of discovering and establishing routes to be utilized by insects to have effective movement backward and forward from the nest of the colony to food sources. Such produced paths are the consequence of harmonious interactions among a huge number of relatively simple entities that model routes and provide information about their characteristics to others simultaneously by making use of a variety of communication approaches, including indirect and direct. The foraging behaviors of these insect colonies are adaptive of environmental disparities, fully distributed, robust to individual loss, as well as scalable. An analogy between these biological organizations and routing in WSN is observed.

ACO-based routing approaches in WSNs can be categorized [171] into multiple categories as shown in Figure 2.19. For operation behavior, ACO-based routing focuses on routing keeping transmission distance and energy level into consideration. The primary operation of the energy metric is to elect relay SN with higher energy, but the primary aim, of later is to elect appropriate transmission distance for each SN. As per the ultimate objective, ACO-oriented routing may be categorized into routing for lifetime extension and with QoS requirements. The ultimate aim of the former is to enhance WSN lifespan, while another one intends to deliver exact QoS services. On network topology in WSNs, ACO-oriented routing includes Flat and hierarchical types of routing. In the former, each SN performs the same job of route searching whereas, in latter, numerous SNs gets arranged into a group and route election is performed among different clusters.

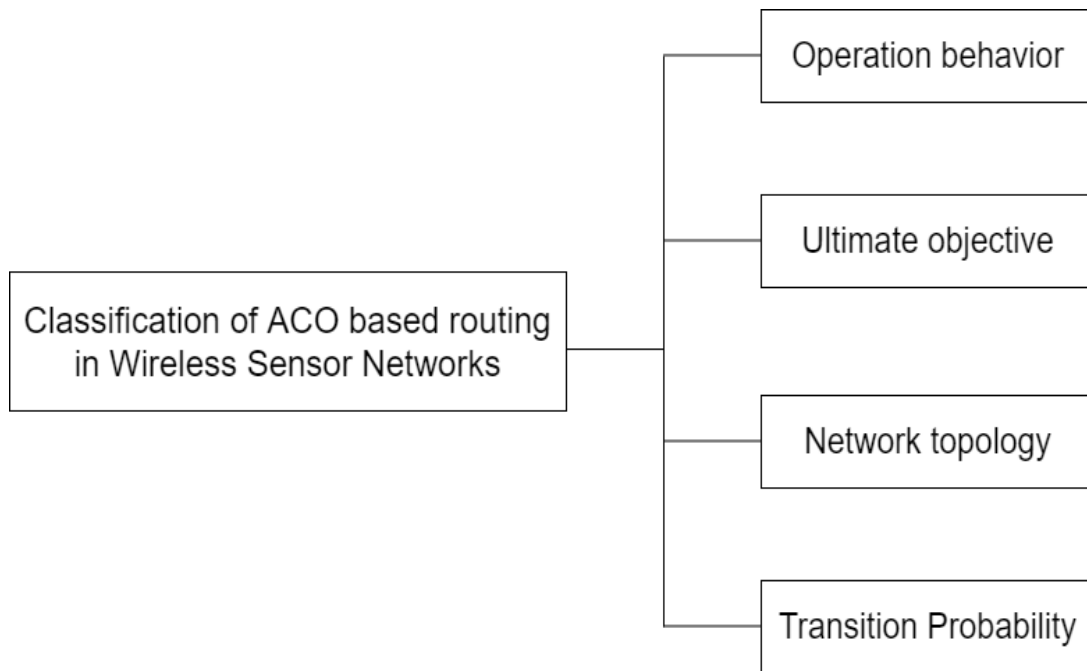

Fig. 2.19 Categories of ACO-based routing techniques in WSN

Camilo et.al. proposed Basic Ant-Based Routing (BABR)[172], which aims to diminish route distance and attain load balance. During path construction, the energy level of SNs and path lengths to be built are considered for updating the pheromone trail. Routes are formed using forward and backward ants. When an ant comes to target SN, it journeys backward through the visited path and according to energy quality and SNs' count of the route, updates the pheromone trail. A forward ant is produced at regular intervals with the task of finding a path until the target. Forward ant elects next-hop SN as per defined probability. When forward ant arrives at target SN, it becomes a backward ant, the job of which is to update the pheromone trail of the path visited by it earlier, which has been preserved in its memory. The memory of every ant is condensed to just two records, i.e., the last two visited SNs. Before backward ant initiates return journey, terminus SN computes the amount of pheromone that ant shall spread during the trip. On receiving a backward ant approaching from an adjacent SN, receiving SN updates its routing table and when backward ant arrives at SN where it was formed, it completes its entire task.

Energy-Efficient Ant-Based Routing (EEABR) was proposed by Camilo et.al that aims at reducing the transmission load of ants and leading to reduced energy consumption. The energy of SNs and to be created path lengths are considered during path creation, for updating the pheromone trail. Every ant holds a memory to preserve all visited SNs. Every ant stores last two visited SNs in memory to avert storing unnecessary information of SNs.

Each SN retains data of sent and received ant in its memory. The record stored in memory comprises of previous SN, forward SN, a timeout value, and ant identification. On receiving forward ant, SN checks its memory and stores requisite information. After this, SN restarts the timer and forwards ant to the next SN meeting backward ant, SN searches its memory to ascertain the next SN to which, ant shall be sent. On arrival of forwarding ant at its target, the backward ant is created whose job is to update the pheromone trail of the visited path by forwarding ant, and the routing table is accordingly updated. The routing table is used for better pheromone distributions. SN near BS possess more pheromone and push SNs far from the BS to find better paths.

ACO-QoSR, is a reactive QoS-aware routing technique whose objective is to deal with both firm delay requirements as well as limitation of energy and computing resources of SNs [173]. The problem undertaken is to find a route from a sensor node to BS and overcome constraints of restricting overall end-to-end delay to be less than a bounding value and energy residual ratio. When a source wishes to transmit data, it looks in its routing table to find a suitable route. In case, is no appropriate route is found in the routing table, a route inquiry is initiated by ants to locate a new route. ACO-QoSR is designed to favor SNs having higher remaining energy and balance energy consumption accordingly. Pheromone concentration is updated on every route whenever forward ant completes its trips. If the delay is higher than the acceptable threshold, the pheromone of the path shall not increase. Additionally, pheromone tends to be added to route with a higher ratio of the overall remaining energy.

An energy-aware ant colony algorithm (EAACA) is proposed by Cheng et.al. for WSN routing. The objective of this approach is to construct routes with balanced energy depletion, low dissipation, and low transmission distance [174]. While creating a path, the next adjacent SN is selected as per distance of BS, remaining energy of the next SN, and the average remaining energy of route. The approach works in stages of route identification and route maintenance. In the path discovery stage, SNs find all pertinent paths to the destination node by communicating a query packet through forwarding ants. If these ants find destination SN, the destination node generates a response packet through backward ants that go back to communicating SN along with the reverse path and release pheromone. During path maintenance, SNs send numerous probe packets to destination SNs periodically for monitoring the quality of the current paths, simultaneously probing new

paths to terminus SN. To diminish overhead by control packet, the number of probe packets is circumscribed by the density of pheromone.

Mondal et. al. propose a hybrid HRP coined as RFCM-ACO by combining the characteristics of both approaches [175]. In RFCM-ACO, the deployed nodes are divided into a fixed number of clusters using rough fuzzy c-means (RFCM) to get a better degree of control over cluster compactness. RFCM incorporates the concept of a rough set to the basic fuzzy c-means (FCM) [176] proposed by Bezdek. The cluster chains referred to as lower chains are constructed using ant colony optimization (ACO) to reduce chain length. The selection of chain leader (CL) is based on a fuzzy inference system (FIS) [177] for better load balancing. An upper chain consisting of the CL's is constructed using ACO with the election of a super leader (SL) by the FIS. Simulation results establish our claim that RFCM-ACO performs better over LEACH [131], PEGASIS [119], and Hybrid-FCM [178] in respect to WSN lifetime and load distribution. Dhand et.al. proposed Secure Multi-Tier Energy Efficient Routing (SMEER) Protocol [179] which is crossbreeding of Ant Lion optimizer (ALO) with K-means for clustering and Sphere-shaped grid founded multi-curve Elliptic curve cryptographic (ECC) routing (MALOKSER) for minimizing power consumption as well as enhancing data protection of the system. MALOKSER works in two stages. 1st stage introduces a hybrid modified K-means algorithm with ALO for diminishing power consumption of WSN. It dispatches packets from CH to array head to suitably controlling difficulty in energy consumption. The 2nd stage introduces ECC-oriented multi-tier grid routing for routing packets in a spherical manner to lessen packet loss in WSN. Application's security also gets better as intruders are not able to interfere.

Eberhart and Kennedy proposed Particle Swarm Optimization (PSO) [180]. which applies the social behavior of birds' flocking. Animals always move in groups especially fishes and birds but never ram into each other as each group member adjusts its speed and position appropriately. Leading to the reduction in the effort of searching for food. Animals also inform one another about location of food. In PSO, 'bird' represents a single solution and is known as a particle. A fitness value is related to each particle, that assesses the solution's quality. PSO can improve cluster quality, network coverage, and energy efficiency by an optimum selection of CH from SNs. Riham et. al. proposed two-tier PSO giving linear programming (LP) formulation to cluster the SNs and elect optimum CH with CH quality, energy, and network coverage into consideration. The authors also propose the routing approaches that apply particle encoding scheme and appropriate fitness function to

find the best route from these CH to the BS with help of routing tree [181]. Proposed clustering and routing approaches are combined to provide a comprehensive clustering model. Bilandi et al. proposed PSOBAN, a novel PSO based metaheuristic approach for wireless BANs with provision for relay node keeping residual energy and distance into consideration [182] Isabel et. al. proposed an Improved Evolutionary PSO called TCBR [183] for CH selection from SNs in a cluster and a fuzzy oriented trust inference model for secure routing. Kuila et.al. address two issues of clustering and routing using the PSO approach with multiple objective-oriented fitness functions [184]. Linear/Nonlinear programming (LP/NLP) formulations are used that improve delivery ratio, network lifespan, dead SNs, and energy depletion.

Authors in [185] proposed, new approach by joining ACO with PSO to generate Particle with Ant Swarm optimization for steady clusters and with optimum CH selection in the network. Pheromone guidance of ACO is applied locally on PSO to synchronize particles' position for getting the best fitness value and best path from CH to sink which enhances network performance and reduces energy utilization. The authors proposed an algorithm that associates PSO and NNs to enable adding extra SNs to make WSN scalable and secure. Network with fixed BS may suffer from the issue of the hotspot as CHs near BS has more traffic burden leading to delay in transmission. To improve this, Wang et. al. presented a PSO algorithm that is energy competent for mobile sink nodes and some supervisory parameters which reduces transmission delay and lengthens WSN lifespan [186] Sarangi et. al. proposed a new Particle Swarm Optimization Routing (PSOR) protocol [187] to identify optimum route so as WSN consumes lesser energy while communicating data. This approach utilizes energy as a fitness function to identify optimized routes among many possible paths.

2.4.3.3 Bio-Inspired Routing Protocols for WSNs

A bio-inspired approach to routing is an effective mechanism to achieve energy efficiency [188]. Grey Wolf Optimizer (GWO) is a bio-inspired based algorithm to solve real-life constrained problems [189]. It is inspired by the behaviors of grey wolves which mimic the leadership, hierarchy, and hunting mechanisms of grey wolves. GWO applies four types of grey wolves: alpha, beta, delta, and omega for optimization problems implementing mechanisms of hunting, searching, encircling, and attacking. GWO proposes two novel fitness functions for routing and clustering. considering parameters of remaining energy,

the distance of gateway from BS, and load on the gateway. For improving the quality of all the remaining solutions in the population, solution from the population, local best solution from previous iterations, and best solution from the current iteration are retrieved. Lipare et. al. proposed a load-balanced approach to avoid the energy hole problems and achieve energy efficiency [190]. The authors proposed two novel fitness functions for clustering and routing problems to minimize distance and the number of hops traversed.

Cuckoo Search (CS) is inspired by obligate brood parasitism from cuckoo species [191]. These species lay their eggs in the nest of other species with each egg and cuckoo egg representing a solution and a new solution, respectively. Cuckoo optimization is viewed as a population-based and iteration-based algorithm in which a random initial population is produced firstly. After this, two stages related to the evaluation of fitness and suitability of the current population and updating the population are carried out in a repetitive cycle, consecutively till the termination condition of the algorithm is not met. This condition necessitates all the pre-specified iterations of the algorithm to be finished. Khabiri et. al. proposed a Cuckoo optimization-oriented algorithm for energy efficiency in WSNs [192] called COARP. For CH selection, the criterion of remaining SN energy, distance to BS, intra-cluster distance and distances among clusters are used in the proposed cuckoo optimization approach.

Artificial Bee Colony (ABC) is a meta-heuristic algorithm stimulated from the intelligent foraging of honeybees. It mimics the technique in which bees move in search of their food. Artificial bees have their colonies that comprised of three types viz. Onlookers, Scout, and employed. Employed bees have the task of searching food or food source sites. After being employed, the bee is required to communicate with other bees or share information by dancing with nectar amount on finding a food source. Onlookers wait for food in the dancing area. The timespan of Onlookers' dancing depends upon the amount of nectar. The high amount of nectar attracts more bees and their route is followed by many others. The artificial Bee Colony (ABC) algorithm implements the same behavior. Employed bees randomly search for solutions, and the quality of solution depends on nectar amount i.e., fitness value. Celik et. al. proposed a Swarm intelligent self-organizing approach, Bee Wireless Sensor (BeeWS) inspired by the foraging behavior of honeybees to minimize the energy consumption [193]. Approach models the behavior of honeybees according to the structure of WSNs and these models are used to criterion for routing

protocol are determined. After this, a discrete event system specification (DEVS) based environment is used to test the developed environment.

Passino et.al proposed Bacterial Foraging Optimization (BFO) is a Swarm Optimization oriented approach inspired by the foraging of bacteria [194]. BFO mimics the method used by bacteria while moving in search of nutrients. Bacterium takes small steps while searching for nutrients. The same behavior is implemented in the BFO technique wherein solutions are represented by bacterium and fitness value is shown by the number of nutrients. clustering and routing issues are addressed using BFO [195] which utilizes distance and remaining energy for fitness value to optimize network lifetime and diminish energy utilization. Rana et.al proposed a grid-oriented routing algorithm using BFO [196], with the implementation of grid clustering and performing routing with BFO with energy and distance being considered for fitness function so that to improve WSN lifespan making period of stability lengthier. Ari et.al. presented an approach for mobile sensing in WSN, which supports data collection with drones, and after this routing is performed using BFO. Compared with PSO and ABC, energy utilization and network lifespan get enhanced in BFO.

A summary of the most prominent research papers that have been working as the base of the research is shown in Table 2.1.

Table 2.1 Summary of Literature Review

Year	Author(s)	Title	Brief Work Description
2019	Amruta Lipare, Damodar Reddy Edla, Venkatanaresbabu Kuppili [190]	Energy efficient load balancing approach for avoiding energy hole problem in WSN using Grey Wolf Optimizer with novel fitness function	<ul style="list-style-type: none"> Proposes Grey Wolf Optimization (GWOEECR) approach for energy-efficient clustering and routing in WSN. Two novel fitness functions for clustering and routing problems are proposed to minimize distance traversed and number of hops
2019	S. Shadravan, H.R. Naji, V.K. Bardsiri [200]	The Sailfish Optimizer: A novel nature-inspired metaheuristic algorithm for solving constrained engineering optimization problems	<ul style="list-style-type: none"> Approach is inspired by a group of hunting sailfish and uses two types of populations, Sailfish population for intensification of the search around the best so far Sardine's population for diversification of the search space.
2019	A. Anhar, R. Nilavalan [105]	Multi-hop hierarchical routing based on the node health status in wireless sensor network	<ul style="list-style-type: none"> Node health status is introduced in choosing (CH) in order to avoid route breakages. CHs transmit their data to the closest CH which is in the direction of the BS

			<ul style="list-style-type: none"> Cluster optimization is not possible due to uneven distribution of clusters.
2019	Geetika Dhand, S. S. Tyagi [179]	SMEER: Secure Multi-tier Energy Efficient Routing Protocol for Hierarchical Wireless Sensor Networks	<ul style="list-style-type: none"> Hybridization of K-means clustering algorithm with Ant Lion Optimizer for grouping of nodes and optimal CH selection is utilized for better energy efficiency. Main aim of work is to enhance network security and energy savings in the wireless network communication system.
2018	R. A. Isabel, E. Babura [183]	An Optimal Trust Aware Cluster Based Routing Protocol Using Fuzzy Based Trust Inference Model and Improved Evolutionary Particle Swarm Optimization in WBANs	<ul style="list-style-type: none"> For CH selection, Improved Evolutionary PSO (TCBR) is proposed, Fuzzy based trust inference model is used for secure path selection. Self-adaptive greedy buffer allocation and scheduling algorithm (SGBAS) is used to reduce traffic occurrence in the network.
2018	Ahmed Al-Baz Ayman El-Sayed [145]	A new algorithm for cluster head selection in LEACH protocol for wireless sensor networks	<ul style="list-style-type: none"> Protocol improves the total network lifetime based on node rank algorithm It depends on path cost and number of links between nodes to select CH of each cluster. It reflects real weight of specific node to succeed as cluster head.
2018	Gaurav Dhiman, Vijay Kumar [199]	Emperor Penguin Optimizer: A Bio-inspired Algorithm for Engineering Problems	<ul style="list-style-type: none"> Proposes a novel optimization algorithm, called Emperor Penguin Optimizer (EPO), which mimics the huddling behavior of emperor penguins Main steps of EPO are to generate the huddle boundary, compute temperature around the huddle, calculate the distance, and find the effective mover
2018	Zhong-Nan Zhao, JianWang and Hong-Wei Guo [114]	A hierarchical adaptive routing algorithm of wireless sensor network based on software-defined network	<ul style="list-style-type: none"> A software-defined network-based hierarchical adaptive routing algorithm for target tracking applications is proposed. It takes Both network energy and throughput. Uses Hopfield neural network algorithm to find the optimal path among adjacent clusters.
2018	Emrah Bulut and Okan Duru [198]	Analytic Hierarchy Process (AHP) in Maritime Logistics: Theory, Application and Fuzzy Set Integration	<ul style="list-style-type: none"> Conventional AHP methodology, fuzzy set extension (Fuzzy AHP) and its rationale in particular problems are investigated. Theory of AHP is discussed with references to theories in social sciences.
2017	Xiaohui Yuan, Mohamed Elhoseny, Hamdy K. El-Minir, Alaa M. Riad [158]	A Genetic Algorithm-Based, Dynamic Clustering Method Towards Improved WSN Longevity	<ul style="list-style-type: none"> Proposes a genetic algorithm based, self-organizing network clustering. Residual energy, expected energy expenditure, distance to BS, and number

			of nodes in vicinity are used in search for an optimal, dynamic network structure.
2017	Sanjoy Mondal, Prateek Dutta [175]	Energy Efficient Data Gathering in Wireless Sensor Networks Using Rough Fuzzy C-Means and ACO	<ul style="list-style-type: none"> • Energy-efficient load balanced data gathering method based on rough fuzzy c-means and ACO is proposed. • Nodes are deployed using rough fuzzy c-means followed by ACO-based lower and upper chain formation. • Chain leader for lower layer and super leader for upper layer are selected using fuzzy inference system.
2017	Melika Khebiri, Ali Ghaffari [192]	Energy-Aware Clustering-Based Routing in Wireless Sensor Networks Using Cuckoo Optimization Algorithm	<ul style="list-style-type: none"> • An energy-aware clustering-based routing using cuckoo optimization algorithm protocol is proposed. • Four criteria of residual energy, distance to BS, within-cluster distances and distances between cluster is used for CH selection.
2017	Saranraj, G., & Selvamani, K. [185]	Particle with ant swarm optimization for cluster head selection for wireless sensor networks	<ul style="list-style-type: none"> • Approach combines Ant colony with PSO to form Particle with Ant Swarm optimization for stable clusters for optimum CH selection. • Pheromone guidance of ant colony is applied locally on PSO to synchronize position of particles to get best fitness value and find best path from CH.
2017	Faouzi Hidoussi, Homero Toral-Cruz, [37]	PEAL: Power Efficient and Adaptive Latency Hierarchical Routing Protocol for Cluster-Based WSN	<ul style="list-style-type: none"> • Addresses challenge of trade-off between increasing network lifetime and accomplishing acceptable latency. • Setup phase uses advertisement, decision, schedule interaction to setup the CH. • In steady state phase actual data transmission is carried out according to TDMA table.
2016	Wang Ke, Ou Yangrui, Ji Hong, Zhang Heli, Li Xi [125]	Energy aware hierarchical cluster-based routing protocol for WSNs	<ul style="list-style-type: none"> • A novel energy aware hierarchical cluster-based (NEAHC) routing protocol is proposed. • Two goals of minimizing the total energy consumption and ensuring fairness of energy consumption between nodes applied. • Relay node choosing problem is modelled as a nonlinear programming problem.
2015	Riham S.Y. Elhabyan, Mustapha C.E. Yagoub [181]	Two-tier particle swarm optimization protocol for clustering and routing in wireless sensor network	<ul style="list-style-type: none"> • Two Linear Programming formulations for optimal CH selection are proposed. • Two PSO-based algorithms for creating routing tree are proposed. • These two algorithms are combined into a two-tier protocol to give a clustering model.

2015	Tunca, C., Isik, S., Donmez, M. Y., & Ersoy, C. [127]	Ring routing: An energy-efficient routing protocol for wireless sensor networks with a mobile sink	<ul style="list-style-type: none"> • Relay nodes of the ring can be swapped with the normal nodes. • Source node can find the closest relay node in a shorter distance. • If the network is large, the ring structure setup costs may be huge.
2015	B. Baranidharan, B. Santhi, [157]	GAECH: Genetic Algorithm Based Energy Efficient Clustering Hierarchy in Wireless Sensor Networks	<ul style="list-style-type: none"> • The fitness function is enhanced with parameters for balanced clusters and reducing overall energy consumption. • Genetic operators are utilized over random initial population till termination condition. • Best fit chromosome of population represents new cluster architecture.
2014	Tifenn Rault, Abdelmadjid Bouabdallah, Yacine Challal [40]	Energy efficiency in wireless sensor networks: A top-down survey	<ul style="list-style-type: none"> • Proposes two algorithms using an approach that combines Fuzzy c-means and ACO to form cluster and manage transmission. • Fuzzy c-means is used to form predefined number of clusters. • ACO forms a local shortest chain in each cluster. • CH is selected randomly in beginning and in next iteration remaining energy parameter I employed.
2014	Nawar NM, Soliman SE, Kelash HM, El-sayed HS.[146]	Enhancement of Mobility Model for Cluster Hierarchical Routing Protocol in Wireless Sensor Networks	<ul style="list-style-type: none"> • Enhanced LEACH cluster head selection is based on distance and residual energy. • The cluster head is rotated by computing both distance and residual energy of nodes.
2013	Beiranvand, Z., Patooghy, A., & Fazeli, M. [139]	I-LEACH: An efficient routing algorithm to improve performance	<ul style="list-style-type: none"> • It considers the residual energy, distance to the base station, and number of neighbor nodes in selecting a cluster head. • It compares each of above factors with the average of all nodes in the network.
2013	Mo, H., Lee, E., Park, S., & Kim, S. [129]	Virtual line-based data dissemination for mobile sink groups in wireless sensor network	<ul style="list-style-type: none"> • It designs a Virtual Line Structure for data storage, used to collect data from storage. • Source knows location of mobile sinks, and calculates a suitable entry point onto the rail. • Relay node on rail sends data to neighbor nodes on the rail, after which mobile sink will send a data request to the VLS to obtain the data.
2012	Rupesh Mehta, Abhishek Pandey & Pratik Kapadia [134]	Reforming Clusters Using C-LEACH in Wireless Sensor Networks	<ul style="list-style-type: none"> • It proposes an improvement of LEACH algorithm called Equalized Cluster LEACH. • It initializes and maintains uniformly sized clusters located uniformly across network.

			<ul style="list-style-type: none"> • Incorporates the concept of “adoption” where orphaned cluster nodes are efficiently incorporated into neighboring clusters.
2012	Banimelhem, O., & Khasawneh, S [124]	GMCAR: Grid-based multipath with congestion avoidance routing protocol in wireless sensor networks	<ul style="list-style-type: none"> • Network is divided into grids with one leader node in each grid. • Each leader stores a routing table, consisting of grid density and hop count information. • Approach separates high and low traffic providing only single path to the sink in the boundary grid for low traffic. • Provides high traffic multiple paths to the sink with non-boundary grids.
2012	Wang, A., Yang, D., & Sun, D [143]	A clustering algorithm based on energy information and cluster heads expectation for wireless sensor networks	<ul style="list-style-type: none"> • To keep a stable number of cluster heads, LEACH-SWDN uses a sliding window control for the CH selection criteria. • Algorithm dynamically selects CH according to the number of alive nodes. • Considers the initial energy of the nodes, average energy of alive nodes which have not been a CH for that particular cycle.
2009	Kuong-Ho Chen, Jyh-Ming Huang, Chieh-Chuan Hsiao [113]	CHIRON: An Energy-Efficient Chain-Based Hierarchical Routing Protocol in Wireless Sensor Networks	<ul style="list-style-type: none"> • An energy efficient Chain-Based Hierarchical Routing Protocol, to alleviate propagation delay is proposed. • Main idea of approach is to split the sensing field into a number of smaller areas, so that it can create multiple shorter chain
2009	Qiu, W., Skafidas, E., & Hao, P. [119]	Enhanced tree routing for wireless sensor networks	<ul style="list-style-type: none"> • Each sensor node maintains a routing table containing the next hop information. • A node shall choose the path with lowest hop count. • As the routing table stores the next hop information only, the storage and computation cost are relatively less. • Residual energy is not considered to select the path as it is selected based on the minimum hop count.
2008	Minhas Mahmood R, Gopalakrishnan Sathish, Leung Victor CM [153]	Fuzzy algorithms for maximum lifetime routing in wireless sensor networks	<ul style="list-style-type: none"> • This approach optimizes two routing objectives for WSNs simultaneously. • For routing objectives, FMO applies fuzzy membership functions and rules to design cost functions. • Multi-objective path is identified. • Postpones the time of first-node death.
2007	Yi Sangho, Heo Junyoung, Cho Yookun, Hong Jiman [147]	PEACH: power-efficient and adaptive clustering hierarchy protocol for wireless sensor networks	<ul style="list-style-type: none"> • It performs clustering at multiple levels. • Protocol may be applied to both location and location unaware WSNs. • Based on the overheard information, PEACH forms the clusters without additional packet transmission overhead.

2006	Barbancho J, León C, Molina J, Barbancho A. [155]	Giving neurons to sensors: QoS management in wireless sensors networks.	<ul style="list-style-type: none"> • Introduces a Neural Network approach in each node to manage the routing. • As a QoS driven routing algorithm, it considers latency, error rate, duty cycle and throughput to determine the quality of link.
2006	T. Camilo, C. Carreto, J.S. Silva, F. Boavida [172]	An energy-efficient ant-based routing algorithm for wireless sensor networks	<ul style="list-style-type: none"> • During path creation, both energy levels of nodes and to be constructed path lengths are considered to update pheromone trail. • Each ant stores only the last two visited sensor nodes in its memory to avoid storing excessive information. • Each node keeps records of received ant as well as sent ant in its memory.
2005	Luo, H., Ye, F., Cheng, J., Lu, S., & Zhang, L. [122]	Two-Tier Data Dissemination in Large-Scale Wireless Sensor Networks	<ul style="list-style-type: none"> • The grid is divided into multiple, and some nodes are used toward relaying data requested from mobile sinks to the source. • After this, source elects the next relay nodes using a greedy algorithm until data reaches to the boundary of the WSN.
2002	Lindsey, S., Raghavendra, C., & Sivalingam, K. M. [109]	Data gathering algorithms in sensor networks using energy metrics.	<ul style="list-style-type: none"> • Chain can be formed by sink and the nodes. • All nodes know global network information. • Node which is farthest away from sink starts formation and finds closest node as next connection until it arrives at leaders. • Leaders send the aggregated data to the sink and leaders can be rotated.
2001	A. Manjeshwar, D.P. Agrawal, [149]	TEEN: a protocol for enhanced efficiency in wireless sensor networks	<ul style="list-style-type: none"> • Intended to respond to sudden variations in attributes sensed by sensing devices. • It is more suitable for time critical applications.
2000	Wendi Rabiner Heinzelman, Anantha Chandrakasan, Hari Balakrishnan [131]	Energy-Efficient Communication Protocol for Wireless Microsensor Networks	<ul style="list-style-type: none"> • LEACH utilizes the concept of clustering of wireless sensor nodes in an adaptive fashion. • LEACH uses random rotation of cluster heads so that no single node chosen as CH is put under stress.

2.5 Problem Formulation and Research Gaps Identified

Wireless Sensor Networks have real-life applications in all walks of modern-day life from smart homes to battlefield surveillance, monitoring vital health parameters to habitat tracking to keeping an eye on structural health of a structure to improving the quality of drinkable water. WSNs are useful in making the earth a better place to live. Despite all these and more applications, WSNs still face the challenge of sustaining a long life as sensor

nodes have limited energy, and every operation of sensor node including sensing, processing, aggregating the data, and data transmission and receptions consume energy. Data transmission by a sensor node is the prime source of energy depletion and this energy consumption is dependent on distance. As transmission distance increases, the amount of energy depletion increases manifold. Thus, it is vital to reduce energy exhaustion during data communication. An energy-efficient routing approach may help in achieving energy efficiency in data transmission. Hierarchical WSNs employing clustering-based routing have proven to be best on the energy efficiency aspect, though the selection of a CH is an overhead. Recent research to achieve energy efficiency in WSNs has led to the exploration of nature-inspired algorithms. Various researchers have employed these bio and nature-inspired algorithms. The nature-inspired mechanisms have been observed to be providing energy efficiency in WSNs. On the other hand, it has been observed that hybrid optimization approaches for the election of CH mainly rely on some significant parameters like energy, delay, and distance but do not tackle other parameters. For instance, the election of the optimal path in rule-based energy-efficient routing might not select the route that provides high throughput and lesser delay. Thus, there is always a trade-off among vital WSN routing parameters to be resolved. Selection of an optimum CH and identification of route to the base station in energy-efficient manner while keeping multiple QoS objectives into consideration is highly desirable. Based on a thorough literature survey, the following gaps are identified:

- Data transmission is the biggest source of energy depletion and energy depletion increases manifold with an increase in distance, thus developing an energy-efficient routing protocol is a challenge [7].
- If many nodes fail, routing protocols must accommodate the formation of new links and routes to BS. The issue is to have a backup plan for fault tolerance in a way to replace the failed SN without disturbing the topology deployed. [66]
- Attaining the trade-off between energy conservation and QoS is a major challenge for routing protocols in WSNs. Developing a routing protocol satisfying energy as well as QoS parameters is a key concern [93].
- Data transmitted through routing protocols causes a large signalling overhead to establish routes with cluster head selection being an additional overhead, thus selection of optimum CH with consideration for multiple objectives is a challenge [105].

2.6 Research Objectives

Based on the literature survey and gaps identified, the following objectives have been identified:

1. To analyze energy-efficient communication among nodes in hierarchical protocols.
2. To design/devise energy-efficient hierarchical routing protocol(s) for wireless sensor network.
3. To test and compare the designed protocol(s) with existing ones

Research Methodology

The objective of the study is to analyse existing approaches for energy-efficient communication among nodes in hierarchical protocols and to design/devise energy-efficient hierarchical protocol(s) for routing in WSN. The research has been carried out in different phases of requirement specification, experimental setup, result analysis, and comparative analysis to achieve the objective. Various literature related to energy-efficient routing and data communication is surveyed during the requirement specification phase and is described briefly in Chapter 2. The protocols have been studied and categorized into different heads like radio optimization, clustering, sleep/wakeup, battery depletion, hierarchical, location-based, etc. Based on the literature survey, various research gaps have been identified regarding connectivity, throughput, latency, distance, etc. Some of these gaps have been addressed in this research, and two energy-efficient methods, namely FMCB-ER, MCH-EOR and LBNR-LEACH, have been proposed. These methods are detailed in Chapter 4, Chapter 5 and Chapter 6 respectively. The results of the proposed algorithms are tested in a simulated environment. The experimental setup for the sensor network is created in MATLAB environment, and different test cases are designed to test the proposed method.

3.1 Problem Description

WSN comprises small sensor nodes. These sensors sense the data and communicate it to a centralized device called BS or sink. BS is resource and energy-rich and has adequate resources to process the data sent to it. The sensor nodes in WSN are energy and resource-constrained and are equipped with limited processing and storage capabilities. Moreover, the opportunities to supply power to sensor nodes (SNs) to perform the intended tasks are constrained. These wireless sensor nodes are engaged in physically harsh conditions where it is impossible to replace or replenish the batteries of sensor nodes. Once the total energy of the sensor is consumed, it cannot perform its intended job and is considered dead. After the death of that sensor node, the sensor nodes who were communicating the data with that sensor node cannot communicate further with the dead sensor node and hence causes problems in further communication of data which may require identification of alternative routes. To save energy of SNs, many energy-saving mechanisms have been proposed, with

energy-efficient routing being a prominent and successful mechanism to avoid energy depletion as data transmission is a prime source of energy consumption. Also, with the increase in distance between source and destination, more amount of energy is consumed. A hierarchical approach for communications has been identified as the most energy-efficient among all categories of routing protocols for WSN. However, optimal CH election is an overhead that needs to be incurred by sensor nodes while using hierarchical routing. Moreover, cluster heads may die sooner as they have to spend more energy collecting, aggregating, and transferring the data to the other cluster heads or BS. Thus, there is a need to select an optimum CH to sustain for a longer duration. Also, WSNs may suffer from an energy hole problem that arises because energy depletion is comparatively higher for sensor nodes, especially the CH nodes lying closer to the base station as they are receiving more data from other CH nodes comparatively away from BS. Moreover, with the advancements in technology and increasing use of wireless sensor networks in IoT-based applications, hierarchical routing protocols should perform well on energy efficiency and various QoS parameters, including scalability and delay, throughput, and jitter. Thus, keeping the characteristics and challenges of WSN and its routing mechanisms into consideration, the relevant steps are taken to attain the research objectives.

3.2 Requirement Specifications

The hardware and software specifications, that are used for the research work is as follows:

3.2.1 Software Requirements

Operating System: The operating system is required to install and configure MATLAB software for network creation and simulation. The 64-bit Microsoft Windows 8.1 OS is used for this purpose.

MAThworks LABoratory (MATLAB): It is used for simulation and result analysis of proposed protocols. MATLAB is an interactive developmental and research programming environment designed precisely for matrix processing that provides high-performance technical visualization, computation, processing, and programming. It provides an accessible environment wherein the research problem and corresponding solution is expressed using known mathematical notation. *Simulink*, one of the tools provided by MATLAB, gives a graphical interface for modelling and simulation for multi-domain embedded systems.

3.2.2 Hardware Requirements

This section describes the hardware specification for required performing for performing requisite simulations. The minimum system configuration is detailed below.

Processor: AMD x86-64 or Intel processor

Memory Requirements: Minimum of 4 GB RAM with 30 GB of HDD space for MATLAB and related software installation.

Graphics Requirements: Hardware accelerated graphics card supporting OpenGL 3.3 with 1GB GPU memory is recommended.

3.3 Experimental Setup

All the simulation experiments are performed in MATLAB environment. For the FMCB-ER protocol the simulations are executed for 100 seconds for diverse sensor nodes ranging from 100 to 300 with each SN having initial energy of 2J. Antenna type is Omni-directional and region of deployment is 200X200 m. Each data packet is considered to be of 9000 bits. Table 3.1 shows the details of simulation parameters. Figures 3.1, 3.2, and 3.3 shows the experimental setup showing initial node deployment, cluster head selection, and routing.

Table 3.1 Simulation Parameters for FMCB-ER

Considered Parameter	Respective Value
Simulation Tool	MATLAB 2018 a
Simulation Time	100 Seconds
Number of Sensor Nodes	100 – 300
Initial energy of SN	2 J
Region of Deployment	200m×200m
Initial energy of network	Varying based on the number of nodes
Packet size	9000 bits
Sink location	200m, 200m
Maximum network throughput	1024 kb
Antenna Type	Omni Directional
Base Routing Protocol	LEACH
Topology	Point-to-Point

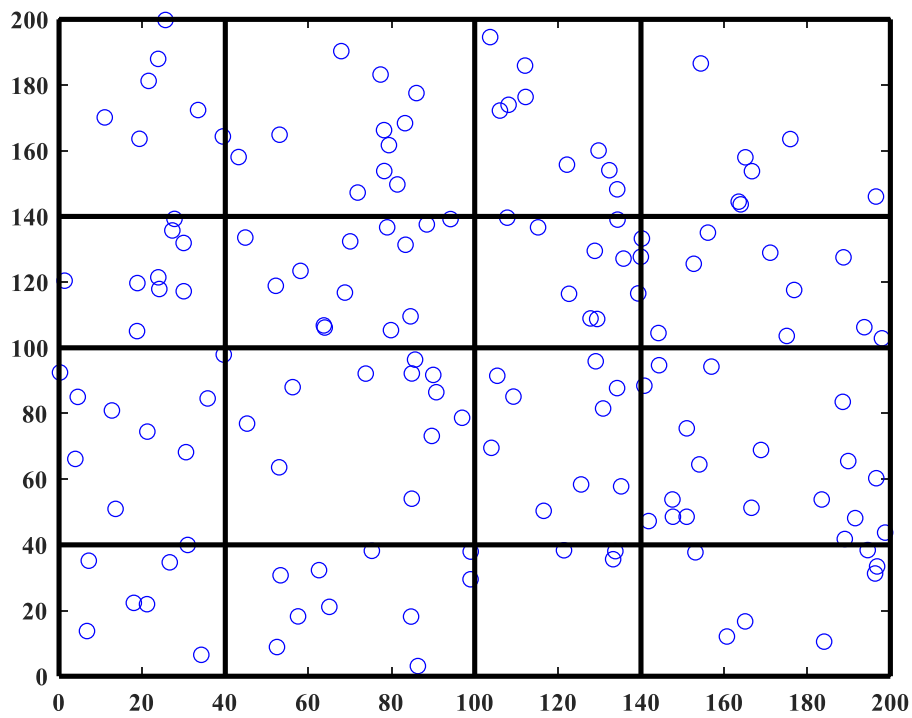

Fig. 3.1 Initial node deployment FMCB-ER

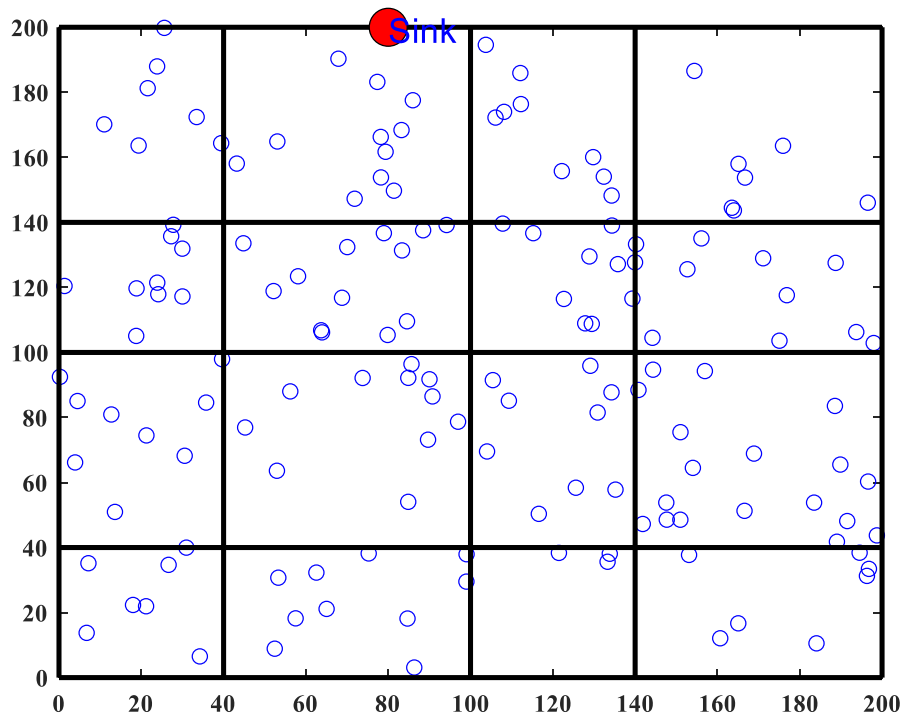

Fig. 3.2 Initial Node Deployment with Sink FMCB-ER

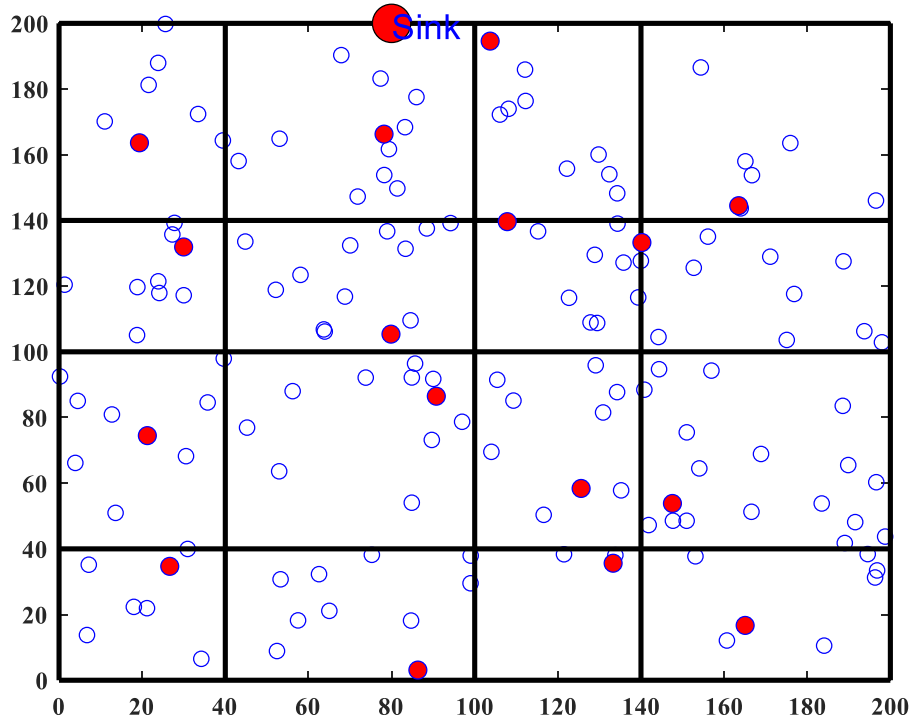

Fig. 3.3 Cluster Head selection FMCB-ER

The MCH-EOR protocol simulation is performed on different sensor nodes varying in the range of 100 to 500 with each sensor node carrying an initial energy of 2J. The packet size considered is 10000 bits with simulation being executed for a maximum of 3500 rounds in the deployment area of 200X200 m. The simulation parameters are shown in Table 3.2. The results obtained from simulation of proposed protocols are encouraging and are detailed in Chapter 4 and Chapter 5.

Table 3.2 Simulation Parameters for MCH-EOR

Parameter	Used values
Simulation Tool	MATLAB 2018 a
Deployment area	200 m × 200 m
Nodes	100 – 500
Clusters	Differs
Initial node energy	2 J
Initial network energy	Varies based on the number of nodes
Packet size	10000 bits
Max network throughput	1 Mbps
Sink location	(0, 0)
Range of nodes	30 – 40 m
Max number of Rounds	3500

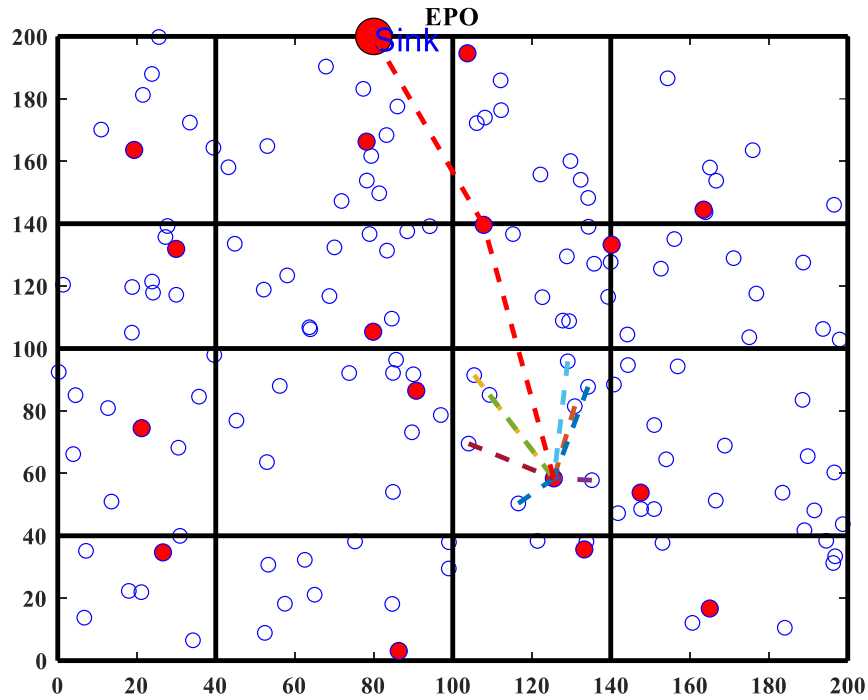

Fig. 3.4 Routing in WSN MCH-EOR

The simulation for LBNR-LEACH is performed with simulation parameter shown in Table 3.3. Here maximum of 400 sensor nodes are considered for simulation. The simulation is carried out for 1000ms with a packet size of 512. The nodes are randomly deployed and clustered. Each cluster is having more than one CH with interconnected links. Initially the CH is selected based on node ranking (link connectivity) as depicted by node-rank LEACH algorithm. For next round of iteration the candidate CHs are estimated for link quality as well as for energy consumed (network load). This approach allow rotation of the CHs in a cluster and help in saving energy.

Table 3.3: LBNR-LEACH Simulation Parameters

Simulations Parameters	Parameter Value
Quantity of Nodes	10-400
NS Version	NS-2.35
Duration of Simulation	1000 ms
Interface Queue	DropTail
Size of Packet in bytes	512
Network Interface	Wireless
Data Rate	10 bps

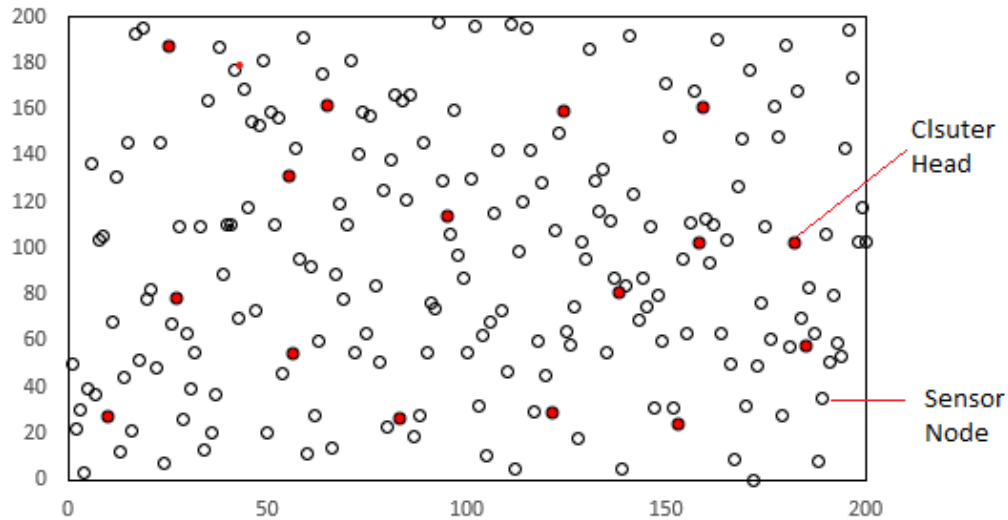

Fig. 3.5 Network setup for LBNR-LEACH

3.4 Comparative Statement

This section provides a comparative analysis of the two proposed routing protocols. The FMCB-ER routing protocol uses TOPSIS [197] and Fuzzy-AHP [198] for optimum CH selection and Emperor Penguin Optimizer [199] approach for route identification. The approach is compared with LEACH [131], Cuckoo Optimization Algorithm based Routing Protocol (COARP) [192], Rough Fuzzy c-means and Ant Colony Optimization RFCM-ACO [175] and trust aware cluster-based routing (TCBR) [183]. The considered parameters for comparison are energy consumption, network lifespan, number of live SNs and dead node count. FMCB-ER not only fares better in energy efficiency but also provides more excellent value on QoS parameters. Optimization technique is used for optimal path selection between sensor-nodes and BS. The MCH-EOR performs unequal clustering for cluster formation and utilizes a Multi-Criteria-Decision-Making approach to elect the cluster head optimally. After cluster formation and CH selection, it employs the SailFish [200]. Requisite simulations are carried out for comparative evaluation of proposed MCH-EOR with various routing approaches of Genetic Algorithm Based, Self-Organizing Network Clustering (GASONeC) [158], method Grey Wolf Optimization Energy Efficient Cluster Routing GWOECCR [190], Two tier Particle Swarm Optimization for Clustering and Routing (protocol. [191], and Ant Lion Optimization based SMEER: Secure Multi-tier Energy Efficient Routing Protocol [189] approaches. Results attained by simulation show that the MCH-EOR approach performs well on the energy efficiency front with better

network lifetime, less energy consumption, lower count of dead nodes, and a higher count of alive nodes compared to existing compared approaches. The LBNR-LEACH is compared with LEACH [131], improved LEACH [146] and NR-LEACH [145] protocols and is found to perform better than its ancestors.

3.5 Thesis Contributions

The contributions of the research work are as follows: -

1. It has proposed a new technique called Adaptive Fuzzy Multi-Criteria Decision-Making approach (AF-MCDM) that combines, Technique for Order Preference by Similarity to an Ideal Solution (TOPSIS) and Fuzzy Analytic Hierarchy Process (F-AHP), for CH selection by optimal decision making.
2. The proposed MCH-EOR scheme provides an extended lifetime to WSNs by employing an energy-efficient clustering. It uses a multi-objective technique and SailFish Optimizer (SFO) algorithm for optimization.
3. An effective fitness function with multi-objective criteria is developed to nominate the best CH in WSN.
4. SFO based algorithm is developed, enhancing the rate of convergence and maximizing convergence's ability to achieve the optimal solution to select the energy-efficient path for reliable data transmission.
5. It has proposed a new technique called Fuzzy Multi-criteria Clustering and Bio-inspired Energy-efficient Routing (FMCB-ER). It uses fuzzy rules for clustering and Emperor Penguin Optimizer (EPO) for optimization.
6. FMCB-ER with EPO is used to find the best path for data transmission.
7. It has proposed an improvement to the Node-Rank LEACH algorithm to select the cluster head.

Chapter 4

Fuzzy Multi Criteria Clustering and Bio-Inspired Energy-Efficient Routing (FMCB-ER)

Fuzzy Multi-criteria Clustering and Bio-inspired Energy-efficient Routing (FMCB-ER)¹ is a grid-based clustering approach. The objective of the proposed approach is to provide an energy efficient cluster head (CH) selection and routing to improve lifetime of sensor network. It is suitable for a variety of environments and can effectively handle large amount of cluster heads even on large deployment area. Here, an adaptive Fuzzy Multi-Criteria Decision-Making (AF-MCDM) that combines Fuzzy-AHP and TOPSIS is used for electing an optimal cluster head (CH). For this purpose, it considers three major parameters energy, QoS, and node position, along with their six sub-criteria. After CH selection, the Emperor Penguin Optimization (EPO) is used to find the optimal route for data transmission from elected CH to the BS. The proposed approach has been evaluated and compared with other existing routing approaches on various parameters such as energy consumption, lifetime, throughput, end-to-end delay, jitter, packet delivery ratio, latency, number of dead and alive nodes. Simulation results show that the proposed approach performs better than the compared approaches on the above-deliberated parameters, reduces energy consumption up to 13%, and increases the network lifespan up to 8%.

4.1 FMCB-ER Protocol Description

FMCB-ER is designed in three steps cluster formation, cluster head election, and route identification from sensor node to sink. Grid-based clustering is used for cluster formation. After forming the cluster, AHP (Analytic Hierarchy Process) and TOPSIS (Technique for Order of Preference by Similarity to Ideal Solution) methods are used to select optimum CH. It considers three main parameters distance, node position, energy, and impact on QoS. After CH selection Emperor Penguin Optimizer (EPO) is used for optimal path selection to

The contents are published in ¹ Mehta, D., Saxena, S. Hierarchical WSN protocol with fuzzy multi-criteria clustering and bio-inspired energy-efficient routing (FMCB-ER). *Multimed Tools Appl* (2020). <https://doi.org/10.1007/s11042-020-09633-8>

minimize energy consumption on sensor nodes. Figure 4.1 shows the architecture of the FMCB-ER protocol.

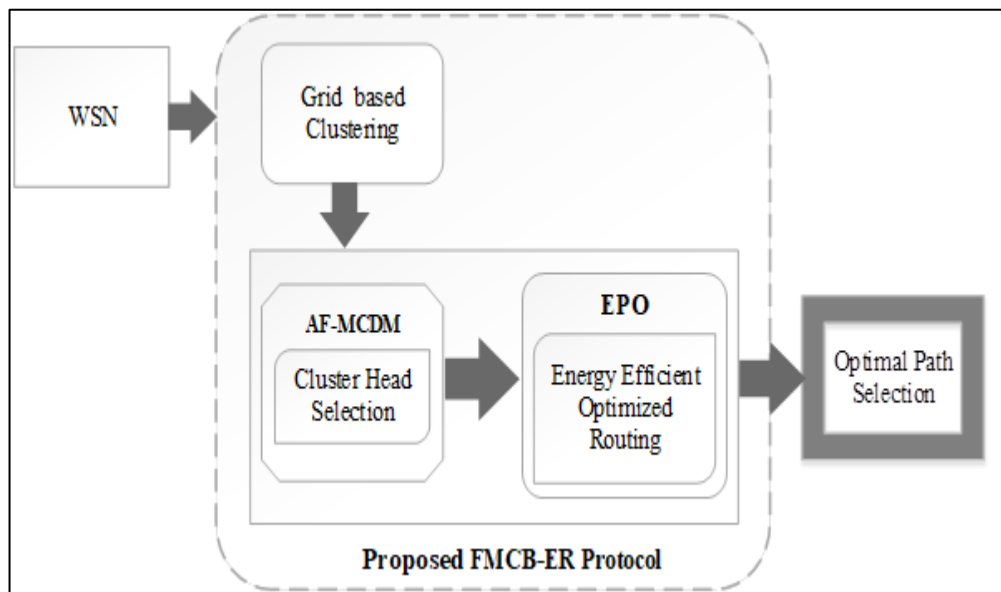

Fig. 4.1 Flow Diagram of FMCB-ER protocol

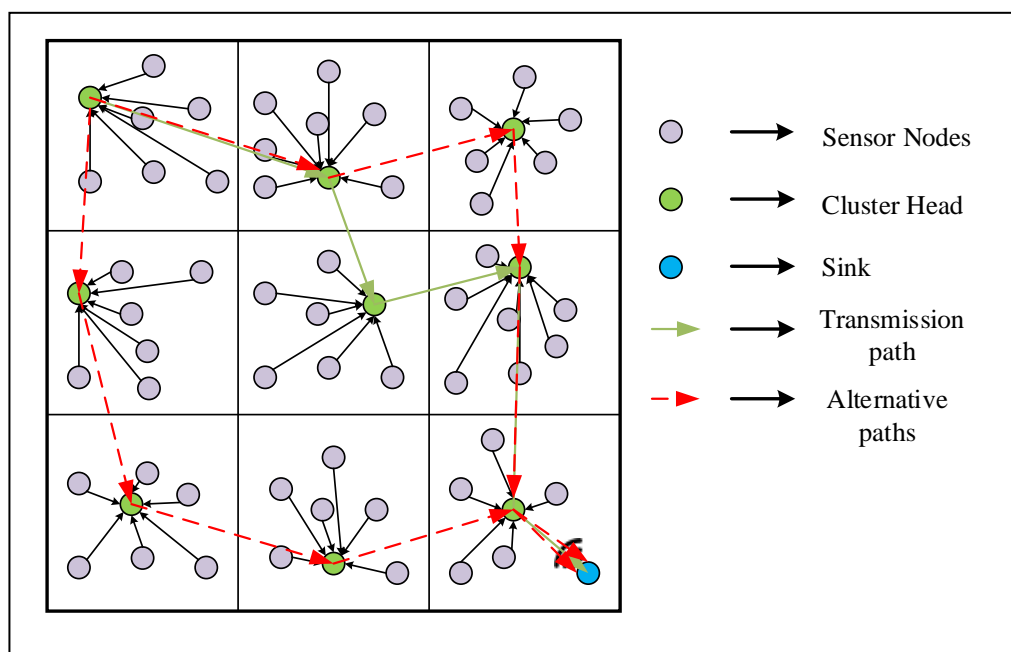

Fig. 4.2 Deployment structure of proposed network model

4.1.1 Network Model

The network model shows the deployment and arrangement of sensor nodes in FMCB-ER. It includes many sensor nodes and is deployed based on the grid-based hierarchical

structure, as shown in Figure 4.2. The assumptions made for the network model are as follows:

- All the sensor nodes in the WSN have a similar configuration.
- The initial energy of each sensor is 2 joules.
- Nodes are randomly hierarchically deployed inside the grid.
- The base station and all other sensor nodes in this network are static.

4.1.2 Radio Energy Model

The energy model helps estimate energy consumed during the data transmission, receiving the transmitted data by another sensor node and data gathering by a sensor node. The energy model presented in [201] is used in FMCB-ER. Energy model considers that 1 bit of data is transmitted from the sender node a to neighbour node b on a distance $dis(a, b)$ shall consume $En(a, b)$ energy given by Eq. (4.1). Energy consumption is categorized into three parts. The *first* part indicates the energy consumed on node a for initiating the outgoing signal. The *second* part indicates the energy spent for communicating data from sensor node a to b . The *third* part shows the energy consumed in receiving data by sensor node transmitted by sensor node a .

$$En(a, b) = Cn_1 + Cn_2 \times dis(a, b) \times \alpha \quad (4.1)$$

Here, Cn_1 and Cn_2 denote constant value with the base of wireless devices type and application environment, and α denotes the path loss constant.

4.1.3 Grid Cluster Creation

The steps included in the formation of grid cluster are discussed below:

Step 1: The whole network area is segmented equally into n number of rectangular lanes, and it is parallel to y-axis along the width Wid and length Len . The lanes are numbered from 1 to n (left to right).

Step 2: Every lane is segmented into several grids, and it is parallel to the x-axis. The grids present in every lane rely on the location of the lane and the distance among the sink. Every grid has its *ID* and is determined by a *tuple* (a, b) , it represents the a^{th} grid and b^{th} lane. The grid ID of all grids is shown in Figure 4.3. The boundary of grid is given by Eq. (4.2),

$$\begin{cases} (c-1) \times Wid < b \leq c \times Wid; \\ \sum_{l=0}^{q-1} h_{cl} < a \leq \sum_{l=0}^q h_{pk}; c = 1, 2, \dots, n; q = 1, \dots, m \end{cases} \quad (4.2)$$

In Eq. (4.2), h_{cl} represents the grid's height at column c and line l . To identify the level and grid of the node Algorithm 4.1 is used.

(5,1)	(5,2)	(5,3)	(5,4)	(5,5)
(4,1)	(4,2)	(4,3)	(4,4)	(4,5)
(3,1)	(3,2)	(3,3)	(3,4)	(3,5)
(2,1)	(2,2)	(2,3)	(2,4)	(2,5)
(1,1)	(1,2)	(1,3)	(1,4)	(1,5)

Fig. 4.3 Grid with grid ID and lane

Algorithm 4.1 Identifying level and grid of node

Input: x and y coordinates of i^{th} node, boundary equation.

Output: ID of grid and identified level

1. **Begin**
 2. Identify the vertical direction,
 3. $a = x/\text{Wid}$
 4. Estimate the horizontal direction,
- $$b = \sum_{l=0}^i h_{cl}$$
5. **Define** ID of grid (a, b) and level (i) = a .
 6. Send position of Grid node to the BS
 7. **For** $\forall n \in \text{GC}$ compute Euclidean distance d_{ij}
 8. $d_{ij} = \sqrt{(x_j - x_i)^2 + (y_j - y_i)^2}$
 9. **For** $\forall n \in \text{the GC}$ repeat
 10. **Set** $Oa(b)$ =rank of node b in neighbour list of node a ;
 11. **Set** $\text{bound} = \min(Oa(b), K)$, $\text{sum} = 0$;
 12. **End For**
 13. **For** each node m in $\{1, \dots, \text{bound}\}$
 14. **Set** Fa = m -th neighbour Fa in neighbour list of node b ;
 15. **If** $Ob(Fa) > K$
 16. $\text{sum} = \text{sum} + 1$;
 17. **End If**
 18. **End For**
-

-
19. **Set** distance (a, b) =sum;
 20. **If** distance (a, b) <1.5
 21. Merge neighbour list a, b;
 22. **End If**
 23. **End**
-

4.1.4 Cluster Head Selection

At this point, three different criteria have been considered, namely, QoS impact of nodes, the status of energy, and the position of nodes. The optimal cluster head (CH) on each cluster is elected using AHP and TOPSIS [197]. The AHP helps to evaluate the weights for all the criteria, and the TOPSIS is utilized for ranking the clusters. The criterion and their sub-criteria are shown in Figure 4.4.

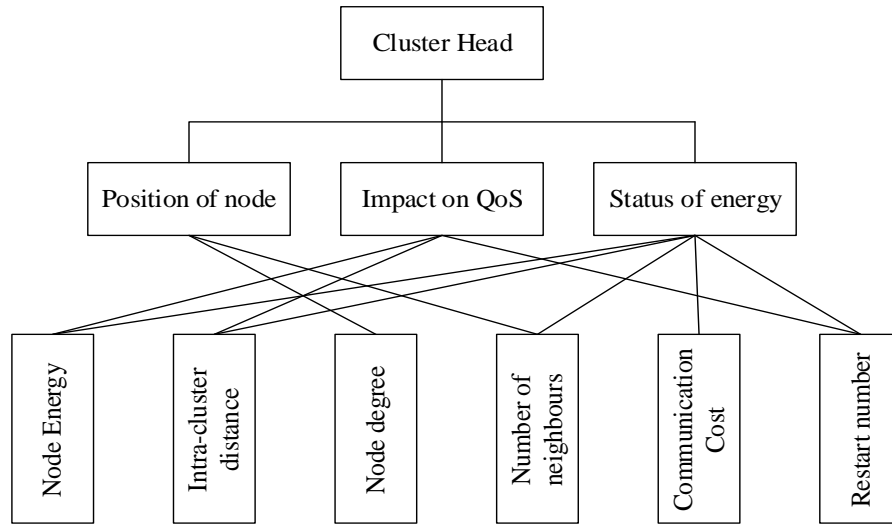

Fig. 4.4 Decision making criterion

There are six sub-criteria namely number of neighbours, intra-cluster distance, node energy, communication cost, and node degree and restart number that have also been utilized. The rank and fuzzy membership values are given in Table 4.1. The description of six sub-criterion are as follows:

i. Node energy: According to this criterion, the sensor node with more residual energy is selected as CH. Since CH is responsible for significant processes like data gathering, transmission, and aggregation, it requires considerably more energy to accomplish its intended tasks. The energy of an SN is given by Eq. (4.3).

$$\text{Node}_{En} = \sum_{i=1}^n \frac{1}{En_{CH_i}} \quad (4.3)$$

Here, n specifies number of cluster heads and En_{CH_i} depicts remaining energy of i^{th} CH.

ii. Intra-cluster distance: It depicts the distance between CH and cluster member nodes. It can enhance the link quality between CH and CMs and provide better quality cluster quality. The intra-cluster distance can be estimated by Eq. (4.4).

$$\text{InC}_{\text{Dis}} = \sum_{i=1}^n \left[\frac{\sum_{j=1}^{|\text{CM}_i|} \text{dis}(\text{CH}_i, \text{CM}_j)}{|\text{CM}_i|} \right] \quad (4.4)$$

In above equation, the Euclidian distance among the i^{th} CH and j^{th} CM is described as $\text{dis}(\text{CH}_i, \text{CM}_j)$.

iii. Node degree: The degree of CH refers to the reachable to the cluster member nodes (CM) nodes and is concerned with balancing the load of CHs. Node degree of a CH is given by Eq. (4.5).

$$\text{Node}_{\text{Dg}} = \sum_{i=1}^n \text{CM}_i \quad (4.5)$$

Here CM_i indicate members of i^{th} CH.

iv. Number of neighbours: It is challenging to identify the number of neighboring nodes available for a sensor node. Sensor node with maximum possibility is selected as CH, and Eq (4.6) estimates number of neighbours.

$$\text{Node} = \frac{|n_i - n_0|}{n_0} \quad (4.6)$$

In the above equation, n_i depicts adjacent nodes of a node and n_0 shows optimal number of neighbour nodes.

v. Communication Cost: It represents the cost of transmitting the data from communicating node to its other neighbouring nodes and is estimated by Eq. (4.7).

$$\text{CC} = \frac{\text{dis}_{\text{Avg}}^2}{\text{dis}_0^2} \quad (4.7)$$

Here, dis_{Avg} shows distance between the communicating node and the neighbouring nodes whereas dis_0 presents dissemination radius of the sensor nodes.

vi. Restart number: In WSN based systems, there is a possibility of malfunctions due to software or hardware issues because of its inherent volatile structure. These concerns can be resolved by an ombudsman circuit that enables the sensor node to restart and continue functioning. This process can also eat some amount of energy represented by restart number and is estimated by Eq. (4.8),

$$ReNum = 1 - \frac{ReNum_0 - ReNum_{min}}{ReNum_{max} - ReNum_{min}} \quad (4.8)$$

Here, $ReNum_{max}$ and $ReNum_{min}$ depict the minimum and maximum restart number established from the neighbours respectively. Whole restart number after the deployment of network is represented as $ReNum$. The attained sub-criteria values of every SN on the pre-defined fuzzy membership values are shown in Table 4.1.

Table 4.1 Rank and fuzzy membership values

Rank	Membership values
Very low	(0.00, 0.15, 0.07, 0.31, 0.23, 0.39)
Low	(0.20, 0.34, 0.26, 0.43, 0.38, 0.46)
Medium	(0.40, 0.52, 0.45, 0.64, 0.59, 0.67)
High	(0.60, 0.71, 0.64, 0.82, 0.75, 0.85)
Very high	(0.80, 0.93, 0.87, 0.99, 0.96, 1.0)

4.1.4.1 Weight Estimation of Criteria with Fuzzy AHP

The fuzzy AHP is one of the finest techniques for carrying out the Multi-Criteria Decision Making (MCDM) process. It allows weights to every criterion based on defined objectives of application and preferences of users. The steps required for weight calculation in the fuzzy AHP process are as follows.

Step 1: Make a pairwise comparison decision matrix as given by Eq. (4.9),

$$AHP = \begin{pmatrix} Cr_{11} & Cr_{12} & \cdots & \cdots & Cr_{1n} \\ Cr_{21} & Cr_{22} & \cdots & \cdots & Cr_{2n} \\ \vdots & \vdots & \vdots & \ddots & \vdots \\ Cr_{n1} & Cr_{n2} & \cdots & \cdots & Cr_{nn} \end{pmatrix} \quad (4.9)$$

Where, $Cr_{ii} = 1, Cr_{ji} = \frac{1}{Cr_{ij}}$. The elements Cr_{ij} are acquired from Table 4.1.

Step 2: Estimate the normalized decision matrix by Eq. (4.10),

$$E_{ij} = \frac{Cr_{ij}}{\sum_{i=1}^n Cr_{ij}} \quad (4.10)$$

Step 3: Estimate weighted normalized decision matrix using Eq. (4.11),

$$Wl_i = \frac{\sum_{j=1}^n E_{ij}}{n} \text{ subject to } \sum_{j=1}^n Wl_i = 1 \quad (4.11)$$

Here, the n describes the criteria number. The weight value obtained for every ranked node is updated and initialized into TOPSIS for electing the finest CH.

4.1.4.2 Ranking for Cluster Head Selection

TOPSIS is used for CH ranking. The core idea is to find the lowest and the longest distance from positive ideal and negative ideal solutions. Decision-making process steps for electing CH are given below:

Step 1: Create decision matrix according to acquired weights of criteria by Eq. (4.12),

$$DM = \begin{pmatrix} d_{11} & d_{12} & \cdots & \cdots & d_{1m} \\ d_{21} & d_{22} & \cdots & \cdots & d_{2m} \\ \vdots & \vdots & \vdots & \ddots & \vdots \\ d_{n1} & d_{n1} & \cdots & \cdots & d_{nm} \end{pmatrix} \quad (4.12)$$

Here, the d_{ij} is assessment of alternate A_i in terms of criterion C_j .

Step 2: Normalization of formed decision matrix is done using Euclidean normalization and is given by Eq. (4.13),

$$f_{ij} = \frac{d_{ij}}{\sqrt{\sum_{i=1}^n d_{ij}^2}} \quad (4.13)$$

Where, $i = 1, \dots, n$ and $j = 1, \dots, m$

Step 3: Calculate weighted normalized decision matrix by Eq. (4.14),

$$W2_{ij} = W_j * f_{ij}, \text{ and } \sum_{j=1}^m W_j = 1 \quad (4.14)$$

Step 4: Estimate the alternatives for both positive and negative ideal solutions by Equations. (4.15) and Eq. (4.16) respectively,

$$AIS^+ = [u_1^+, \dots, u_m^+] = [(\max_i W2_{ij} | i = 1, \dots, n), j = 1, \dots, m] \quad (4.15)$$

$$AIS^- = [u_1^-, \dots, u_m^-] = [(\min_i W2_{ij} | i = 1, \dots, n), j = 1, \dots, m] \quad (4.16)$$

Where, u^+ and u^- indicates the correlated criteria with positive and negative impact.

Step 5: AIS^+ and AIS^- estimate the distance from every alternative node using Eq. (4.17) and Eq. (4.18) respectively,

$$X_1^+ = \sqrt{\sum_{j=1}^m (W2_{ij} - u_j^+)^2}, i = 1, \dots, n \quad (4.17)$$

$$X_1^- = \sqrt{\sum_{j=1}^m (W2_{ij} - u_j^-)^2}, i = 1, \dots, n \quad (4.18)$$

Step 6: Estimate the comparative proximity to ideal solution by Eq. (4.19),

$$CC_i^* = \frac{X_i^-}{X_i^+ + X_i^-}, i = 1, \dots, n \quad (4.19)$$

The alternatives are ranked based on value of CC_i^* and the node with higher CC_i^* value is selected as cluster head.

4.2 Optimal Path Finding with EPO

The Emperor Penguin Optimization (EPO) [199] is utilized to find the optimum path from present CH to BS. It helps to improve the efficiency of multi-hop routing, to minimize the depletion of energy while transmitting. It also decreases the cost of long-distance transmission. The problem formation, fitness function, and EPO routing process is explained below.

4.2.1 Problem Formation and Fitness Function Estimation

If the distance to communicate Dis from communicating cluster head to Sink (Si) is high, an adjacent CH will be designated as relay node for data transmission, which saves more energy compared to direct transmission between communicating SN and sink. Thus, two different parameters are considered for balancing the load and transmitting the data with negligible energy consumption. These parameters are residual energy factor (RE_f) and relative distance factor (D_f), which are regarded as two objective functions and are determined by Eq. (4.20) and Eq. (4.21), respectively.

$$ObjFun_1 = \frac{\max(En(CH_j)) - En(CH_j)}{\max(En(CH_j))} \quad (4.20)$$

$$ObjFun_2 = \frac{Dis(CH_i, CH_j)^2 + Dis(CH_j, Si)^2}{\max(Dis(CH_i, CH_j)^2 + Dis(CH_i, Si)^2)} \quad (4.21)$$

In Eq. (4.20) and Eq. (4.21), $En(CH_j)$ is the residual energy of CHs. The relative distance factor (D_f) relates to summation of distance among the source CH, relay CH node, and sink. It is imperative to select relay sensor node CH_j whenever source node CH_i is distant from BS. For transmitting intended data to BS, the relay node with lower link cost is selected. The fitness function defining link cost among CH_i and CH_j is defined by Eq. (4.22),

$$FF = \sum_{i=1}^n w_i \times \text{ObjFun}_i \quad (4.22)$$

$$\text{Subject to: } \sum_{i=1}^n w_i = 1$$

4.2.2 EPO Based Routing Process

The routing process with EPO is divided into *four* steps as below,

- Random generation of neighbours of cluster heads.
- Estimation of energy among produced CH neighbours
- Estimation of distance among CH neighbours.
- Relocation of best mover

4.2.3 Random Generation of Neighbours of Cluster Heads

During this first step, two adjacent CHs are randomly found by the main within its transmission range. These adjacent neighbouring CHs are elected keeping gradient (transmission or link speed) of the network field into consideration. A complex variable describes this generation process and neighbouring CHs v are defined by its gradient σ and it is given by Eq. (4.23),

$$\sigma = \nabla v \quad (4.23)$$

The complex potential is formed by joining the vector v and is given by Eq. (4.24),

$$F = v + iv \quad (4.24)$$

Where, F shows analytical function on network field and whereas i is a constant.

4.2.4 Estimation of Energy among CH Neighbours

The CH neighbor generation process can save energy on SN and enhance its lifetime due to the efficient election of CHs with high speed in its range. The exploitation and exploration process in the EPO estimates the energy profile. During this, it identifies the remaining energy on CHs. The energy profile is determined by Eq. (4.25).

$$\text{Ene}' = \left(\text{Ene} - \frac{\text{Max}_{ite}}{x - \text{Max}_{ite}} \right)$$

$$\text{Ene} = \begin{cases} 1, & \text{if } \gamma > 1 \\ 0, & \text{if } \gamma < 1 \end{cases} \quad (4.25)$$

In Eq. (4.25), Max_{ite} indicates the highest iteration whereas represents the iteration that needs to transmit the corresponding data packets. The energy value is assumed according to the number of iterations that send data. In case the number of iterations required to transmit data is more than one, the energy value will be taken as 1, whereas the energy value is set to 0 when the number of iterations that need to transmit data is lesser than one.

4.2.5 Distance Estimation among CH Neighbours

Best optimal solution is determined by estimating the distance among the cluster heads. The CH with minimal distance is determined by Eq. (4.26),

$$Dis_{CH} = Abs \left(B_{SA} \left(\vec{K} \right) \cdot B_{OS}(x) - \vec{L} \cdot \vec{P}_{CH}(x) \right) \quad (4.26)$$

In Eq. (4.26), distance among CHs is given as Dis_{CH} , current iteration is given by x whereas B_{OS} shows best optimal solution, position or location of cluster head is given by \vec{P}_{CH} , B_{SA} represents the social forces responsible for moving towards the best search agent (CH). Link speed among the CHs is taken as social force. For avoiding the collision among the CHs, \vec{K} and \vec{L} are utilized and are estimated using following equations,

$$\vec{K} = \left(Mov_p \times \left(Ene' + Nt_{grid}(Acc) \right) \times Rm() \right) - Ene' \quad (4.27)$$

$$Nt_{grid}(Acc) = Abs \left(\vec{B}_{OS} - \vec{P}_{CH} \right) \quad (4.28)$$

$$\vec{L} = Rm() \quad (4.29)$$

Here, Mov_p , gives moving parameter for avoiding collision. It gives gap among the search agents (CHs) with its value being set to 2 here. $Nt_{grid}(Acc)$ represents network grid accuracy and is defined by comparing the variances among the CHs. The random values lie in between [0, 1] and is given by $Rm()$. The best search agent's (CH) election is exploration process and is given by Eq. (4.30).

$$B_{SA} \left(\vec{K} \right) = \left(\sqrt{g \cdot e^{-\frac{x}{h}}} - e^{-x} \right)^2 \quad (4.30)$$

Expression function is described as e in Eq. (4.30). Two control parameters denoted as g and h have been utilized and for getting better exploration and exploitation. During the

experimentation, the cluster heads found on exploration and exploitation are considered as g and h . Optimum CH attained initially with all aspects satisfactorily is designated by the exploration process to transmit the data. The exploitation process specifies the best cluster head found earlier after the exploration process.

4.2.6 Relocating the Mover

The mover here assists the CH to communicate data to the best solution agent attained. Here, the position of best adjacent cluster head node shall be updated, and is specified by Eq. (4.31),

$$\vec{P}_{CH}(x+1) = \vec{B}_{OS}(x) - \vec{K} \cdot \vec{Dis}_{ep} \quad (4.31)$$

$\vec{P}_{CH}(x+1)$ represents the updated position. The next position of cluster head shall be updated with Eq. (4.31). The same process is carried out till the path for reaching the sink is attained.

4.2.7 Steps Involved in EPO Based Routing

The algorithm for EPO based routing is given in Algorithm 4.2. The steps for it are as described below.

Step 1: Initialize the population of CH $\vec{P}_{CH}(x)$.

The value of $x=1, 2, \dots, n$.

Step 2: Initialize parameters for energy profile Ene , collision avoidance \vec{K} and \vec{L} , social forces B_{SA} , iteration, need for transmission γ , and maximum iteration Max_{ite} .

Step 3: Estimate the fitness function for every cluster head using equation 4.22.

Step 4: Identify two adjacent cluster heads randomly with equation 4.23 and 4.24.

Step 5: Estimate energy profile with equation 4.25.

Step 6: Estimate the distance among the CHs through equation 4.26.

Step 7: The position of optimal CH is estimated and updated by means of equation 4.31.

Step 8: Amend the CH in case any of them goes beyond the network field.

Step 9: Estimate the fitness value for the new optimal solution attained and update it on previous one.

Step 10: Stop the process stopping criteria is satisfied and return the attained optimal solution, else go back to step 4.

Algorithm 4.2 Proposed EPO based routing

Input: CH population $P_{CH}(x)$

Output: Position of best optimal CH

1. **Begin**
 2. Initialize the parameters $Ene', \vec{K}, \vec{L}, B_{SA}, \gamma$, and Max_{ite} .
 3. **While** ($x < Max_{ite}$) do
 4. $FF(P_{CH})$ // Estimate fitness function for every CH
 5. $\gamma = Rm()$ // Generate a random number among the range [0,1]
 6. **If** ($\gamma > 1$) then
 7. $Ene = 1$
 8. **Else**
 9. $Ene = 0$
 10. **End If**
 11. $Ene' = \left(Ene - \frac{Max_{ite}}{x - Max_{ite}} \right)$ // Estimate energy profile among CHs
 12. **For** $i = 1$ do
 13. **For** $j = 1$ do
 - Estimate \vec{K} and \vec{L}
 - Estimate the function $B_{SA}()$
 - Update the position of best optimal CH
 14. **End For**
 15. **End For**
 16. Update parameters $Ene', \vec{K}, \vec{L}, B_{SA}, \gamma$, and Max_{ite} .
 17. **If** any CH goes beyond the network field, then amend it
 18. $FF(P_{CH})$ // Estimate fitness function again for updated best CH
 19. **If** it is better, then update it on CH population $x = x + 1$
 20. **End while**
 21. Return P_{CH}
 22. Evaluate the fitness of CHs to become a route forwarder.
 23. **While** termination condition not satisfied.
 24. **For** each CH
 25. Calculate throughput CH_i .
 26. **If** (throughput is High)
 - Select the cluster head node CH_i for data forwarding
 - else**
 - Reject cluster head node CH_i
 27. **If** (node energy is High)
 - Select the cluster head node CH_i for data forwarding
 - else**
 - Reject cluster head node CH_i
 28. **End For**
 29. **If** best path identified
 30. Update the best path as a data forwarding path.
 31. **else**
 32. Go to Line Number 25.
 33. **End If**
 34. **End**
-

4.3 FMCB-ER Performance Evaluation and Result Analysis

The FMCB-ER employs a grid-based clustering mechanism for cluster creation, and CH is nominated by AHP and TOPSIS methods. In determining CH, FMCB-ER considers QoS parameters along with energy efficiency. Performance of the FMCB-ER approach is compared with LEACH [131], COARP [192], RFCM-ACO [175], and TCBR [183] routing approaches in terms of latency, packet delivery ratio, energy consumption throughput, end-to-end delay, and jitter.

4.3.1 Simulation Parameters

The simulations are executed for 100 seconds for the diverse number of sensor nodes ranges from 100 to 300, with each SN having initial energy of 2J. Each data packet is considered to be 9000 bits. Details of simulation parameters are given in Table 4.2.

Table 4.2 Simulation Parameters

Considered Parameter	Respective Value
Simulation Tool	MATLAB 2018 a
Simulation Time	100 Sec
Number of Sensor Nodes	100 – 300
Initial energy of SN	2 J
Region of Deployment	200m×200m
Initial energy of network	Varying based on the number of nodes
Packet size	9000 bits
Sink location	200m, 200m
Maximum network throughput	1024 Kb
Antenna Type	Omni Directional
Base Routing Protocol	LEACH
Topology	Point-to-Point

4.3.2 Simulation Results

Results obtained through simulations for FMCB-ER are as follows:

4.3.2.1 Energy consumption

Energy consumption represents the amount of energy consumed by sensor node and is given by Eq. (4.32).

$$\text{Energy Consumption} = [\sum_{n=1} CH_E(n) + \sum_{m=1} CM_E(M)] \quad (4.32)$$

Here, $CH_E(n)$ represents the energy used by CH whereas $CM_E(m)$ shows the energy used by CM. The results are shown in Figure 6.1 and Table 6.2. The comparison of energy consumption is made for 1000 rounds for different nodes deployment ranging from 100 to

300. The FMCB-ER approach utilizes comparatively less energy for processing the tasks with 100 to 300 sensor nodes. The FMCB-ER diminishes the energy consumption about 0.6mJ in comparison to LEACH. For 300 nodes FMCB-ER exploits less than 0.4mJ of energy and is lowest in comparison to the other compared approaches.

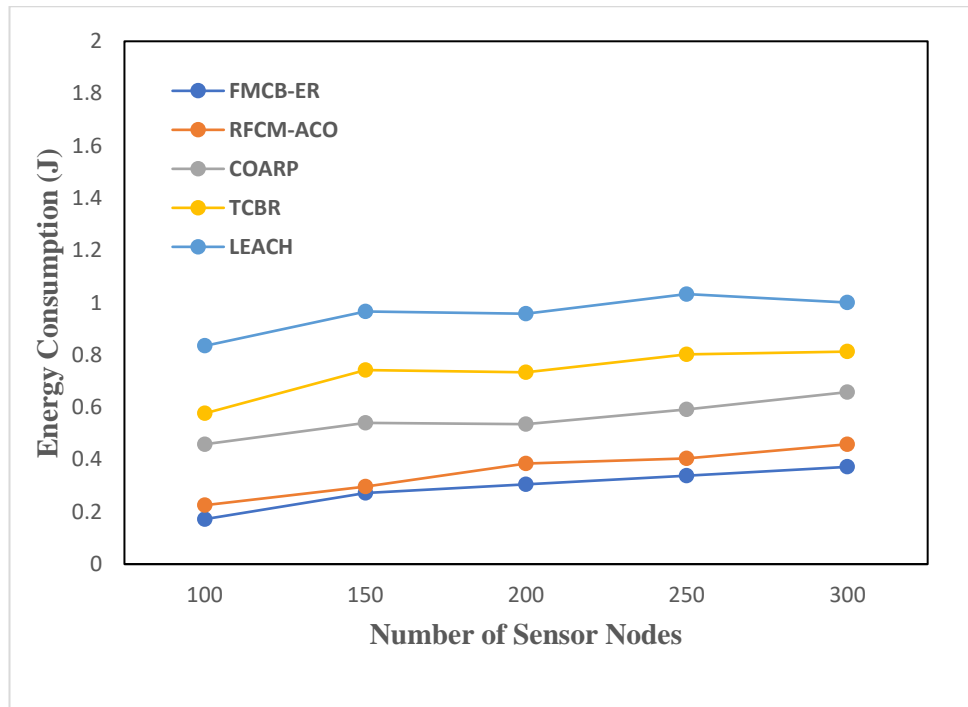

Fig 4.5 Energy consumption comparison

Table 4.3 Energy Consumption (mJ)

Number of nodes => (Approaches)	100	150	200	250	300
FMCB-ER	0.172	0.272	0.305333	0.338667	0.372
RFCM-ACO [175]	0.225432	0.296193	0.384522	0.404081	0.458509
COARP [192]	0.458577	0.540097	0.534899	0.592129	0.657982
TCBR [183]	0.576676	0.742893	0.733774	0.802599	0.813026
LEACH [131]	0.834917	0.96619	0.958301	1.03312	1.000922

It can be comprehended from Table 4.3 that lesser energy is consumed by WSN using FMCB-ER after higher number of rounds which is attributable to energy equalization in grid by electing cluster head keeping into consideration the unexploited energy and distance from BS. Moreover, during data transmission, FMCB-ER identifies to BS by electing energy proficient SN near sink. The outstanding energy of SNs just before first node dies is used in simulation to compare FMCB-ER with various existing approaches.

4.3.2.2 Throughput

Throughput is defined as rate of data transfer to sink, considering varied number of SNs and is given by Eq. (4.33).

$$\text{Throughput} = \frac{\text{no.of pakets sent} * \text{packet size}}{\text{time taken}} \quad (4.33)$$

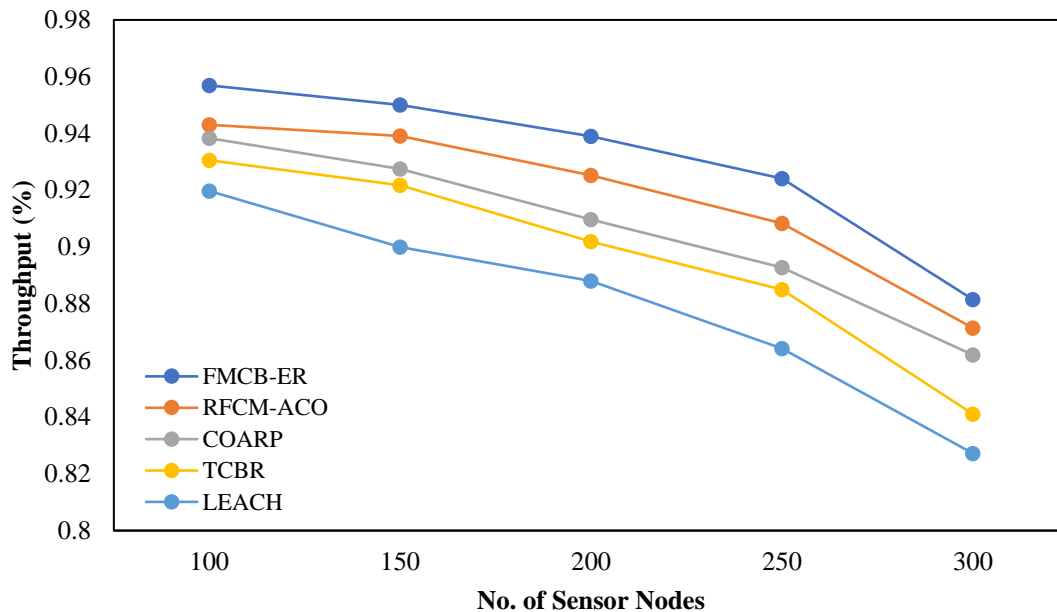

Fig 4.6 Comparison of Throughput (%)

Table 4.4 Throughput (%)

Number of nodes =>	100	150	200	250	300
(Approaches)					
FMCB-ER	0.956924	0.949998	0.939035	0.924091	0.881465
RFCM-ACO [175]	0.943035	0.939146	0.925257	0.908313	0.871424
COARP [192]	0.938313	0.927488	0.909591	0.892757	0.861924
TCBR [183]	0.930535	0.921702	0.901813	0.88498	0.841091
LEACH [131]	0.919702	0.899886	0.888035	0.864146	0.827202

Figure 4.6 and Table 4.4 shows the comparison of achieved values of transmission throughput for different approaches. It can be observed that FMCB-ER realizes throughput of nearly 0.96% for 100 nodes and 0.88% with 300 nodes. In comparison to RFCM-ACO which is the 2nd highest and accomplishes a throughput of 0.94% for 100 nodes and 0.87% for 300 nodes showing that throughput of FMCB-ER is comparatively better than other prevailing routing approaches.

4.3.2.3 End-to-End delay

The amount of time taken for data to be transmitted from sender to destination node is called end-to-end delay and is given by Eq. (4.34).

$$\text{Delay} = \text{Time required to transmit the data} + \text{Time required to process the data} + \text{Time required to deliver the data}$$

(4.34)

Figure 4.7 and Table 4.5, shows end-to-end delay for diverse compared techniques. The results show that FMCB-ER performs better in terms of end-to-end delay in comparison to RFCM-ACO, COARP, TCBR, and LEACH. With increase in number of nodes the end-to-end delay also increases for various compared approaches. FMCB-ER incurs the lowest delay of 2.88s for 100 nodes and 8.8s for 300 nodes.

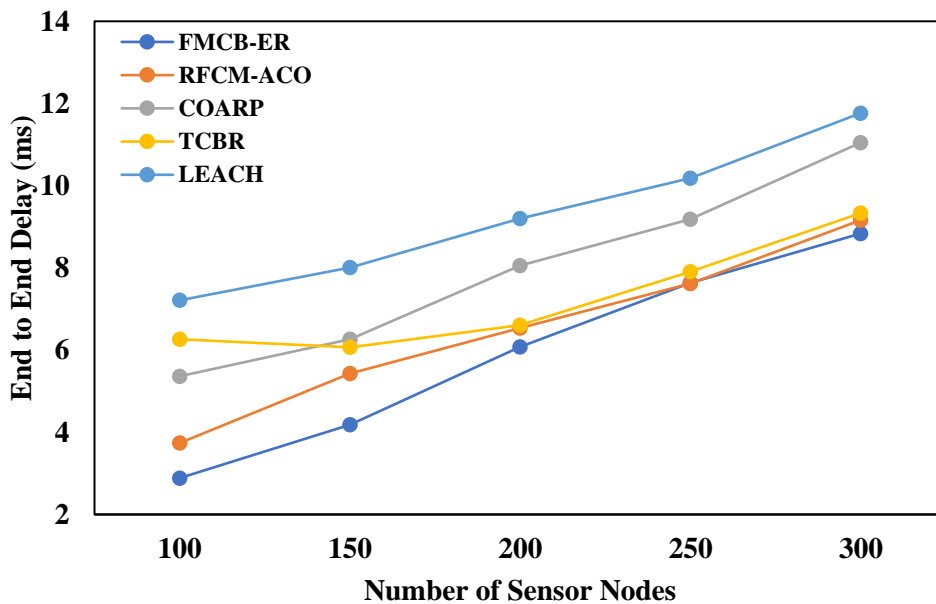

Fig 4.7 Comparison of End-to-End Delay

Table 4.5 End to end delay (ms)

Number of nodes =>	100	150	200	250	300
(Approaches)					
FMCB-ER	2.885469	4.181843	6.080201	7.63411	8.836418
RFCM-ACO [175]	3.738117	5.433812	6.533186	7.616184	9.161644
COARP [192]	5.363435	6.261256	8.053444	9.18179	11.04888
TCBR [183]	6.262625	6.067308	6.604689	7.906584	9.33364
LEACH [131]	7.211246	8.005353	9.20088	10.18117	11.76697

4.3.2.4 Latency

Latency is defined as time taken for a packet to transmit across a network. It can be measured as the Round-Trip Time (RTT) and is defined as the amount of time it takes for a packet to get from a sender node to the receiver node and back. Figure 4.8 and Table 4.6 shows latency in data transmission for various compared methods. FMCB-ER accomplishes better performance in comparison to LEACH, and TCBR, with an improvement of more than 2.5s. For 300 nodes, FMCB-ER realizes latency of 26.3s, RFCM-ACO's has latency of 32.5s, COARP has latency of 31.3s, TCBR has latency of 32.5 and LEACH has latency of 38.6s approximately.

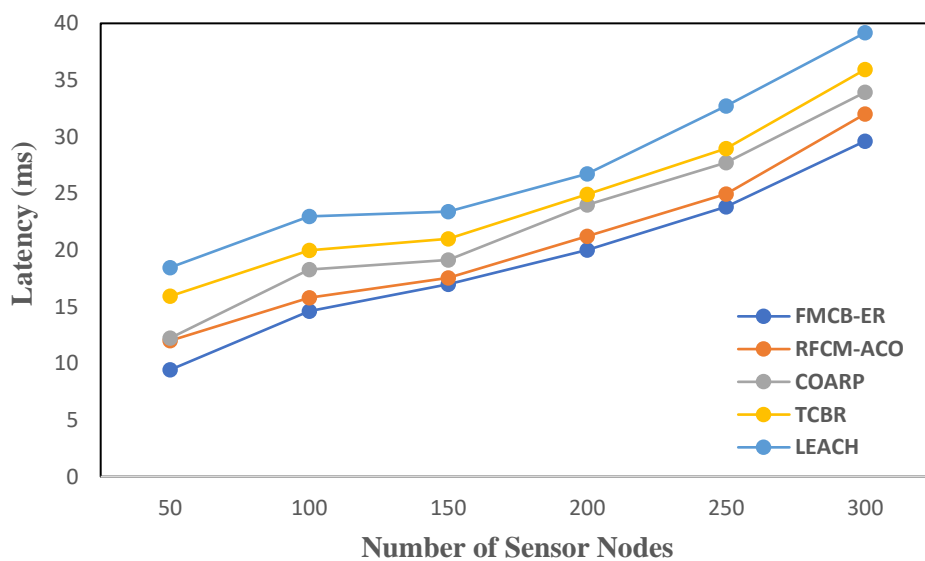

Fig 4.8 Comparison of Latency

Table 4.6 Latency (c)

Number of nodes =>	100	150	200	250	300
(Approaches)					
FMCB-ER	9.427583	14.597001	16.972069	19.993652	23.81823
RFCM-ACO [175]	11.992425	15.792465	17.544864	21.209879	24.94066
COARP [192]	12.225487	18.285381	19.131712	23.979625	27.72178
TCBR [183]	15.924587	19.958049	20.980821	24.918962	28.96297
LEACH [131]	18.457215	22.960625	23.381877	26.721578	32.70455

4.3.2.5 Network Lifetime

Network lifetime illustrates number of rounds after which, SNs in the field shall die while processing their jobs and is given by Eq. (6.4)

$$\text{Network lifetime} = \min_j \left[\frac{\sum_{i=1} CM_{ij} * L_i}{N_j} \right] \quad (4.44)$$

In Eq. (6.4), CM_{ij} represents coverage matrix, Life of SN is given by L_i and N_j represents the number of SNs in k coverage. Coverage matrix CM_{ij} is shown by Eq. (4.45)

$$CM_{ij} = \begin{cases} 1 & \text{if } SN_i \text{ monitors } Tar_j \\ 0 & \text{Otherwise} \end{cases}$$

(4.45)

Here, SN_i specifies SN_s whereas Tar_j represents the target. Life of node L_i and is specified using Eq. (4.46),

$$L_i = \frac{E_0}{EC_i}, 1 \leq i \quad (4.46)$$

Here, E_0 and EC_i represents the initial energy of SN and energy consumption rate of SN respectively. Figure 4.9 and Table 4.7 shows lifetime of network with different compared approaches. Figure 4.9 clearly depicts that proposed approach provide better lifetime for SNs in comparison to other existing protocols. FMCB-ER is able to complete more than 2300 rounds with 300 nodes and for 100 nodes, it is able to process more than 1500 rounds. FMCB-ER is able to extend WSN lifespan because each data aggregator node concentrates only on a limited range and is adjusted according to nodes' distances at the time of grid clustering that helps in preventing overlapping. As represented by Table 4.7, FMCB-ER achieves an enhancement of 4.38%, 13.2%, 12.5% and 21.8% in energy efficiency as compare to RFCM-ACO, COARP, TCBR and LEACH.

Table 4.7 Network lifetime (number of rounds)

Number of nodes =>	100	150	200	250	300
(Approaches)					
FMCB-ER	1444	1593	1816	1980	2272
RFCM-ACO [175]	1336	1504	1728	1883	2173
COARP [192]	1354	1436	1662	1814	1972
TCBR [183]	1402	1583	1630	1832	1988
LEACH [131]	1212	1260	1453	1541	1820

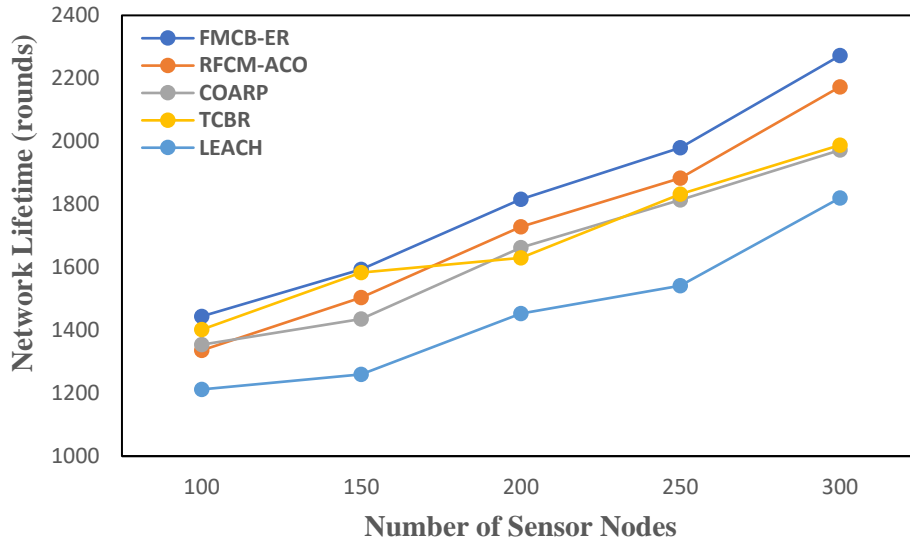

Fig 4.9 Comparison of network lifetime

4.3.2.6 Jitter

The amount of variation in latency/response time, is represented by Jitter. Figure 4.10 and Table 4.8 represent values of jitter for proposed and compared approaches.

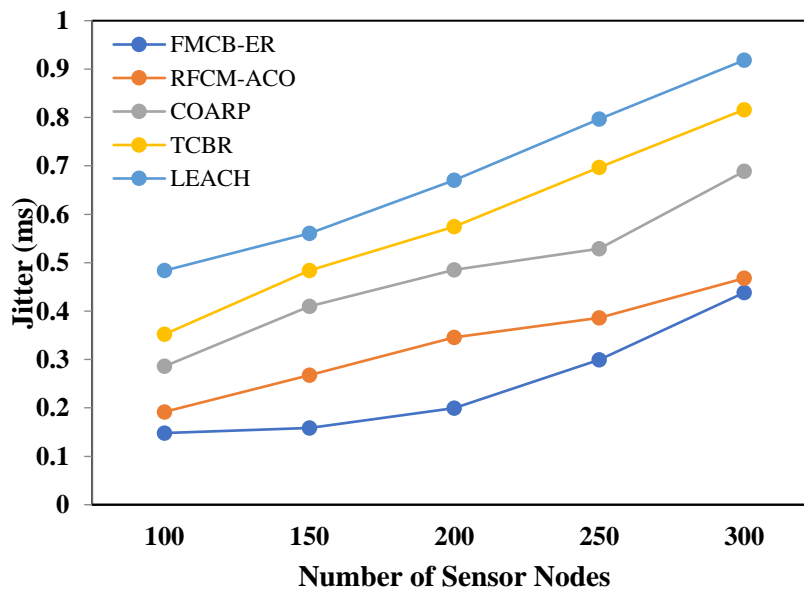

Fig 4.10 Comparison of Jitter

Table 4.8 Jitter (ms)

Number of nodes -> (Approaches)	100	150	200	250	300
FMCB-ER	0.118105	0.154747	0.191918	0.229629	0.267891
RFCM-ACO [175]	0.191918	0.267891	0.346121	0.386114	0.467922
COARP [192]	0.386114	0.509765	0.595402	0.728968	0.869067
TCBR [183]	0.552253	0.683743	0.774919	0.917302	1.01619
LEACH [131]	0.683743	0.821612	0.966336	1.066884	1.118439

FMCB-ER accomplishes better results with lesser jitter level as compared to the other protocols. FMCB-ER shows jitter less than 0.3ms for 300 nodes and about 0.12ms for 100 nodes. Table 4.8 shows that as the count of nodes surges, jitter levels for all approaches including FMCB-ER rise but proposed approach fares comparatively well than other compared techniques with lesser jitter values.

4.3.2.7 Packet delivery ratio

Packet delivery ratio (PDR) is defined as the fraction of data packets successfully transported to sink with diverse number of SNs and is given with Eq. (4.47).

$$\text{Packet delivery ratio} = \frac{\sum \text{no.of packets received}}{\sum \text{no.of packets sent}} \times 100\% \quad (4.47)$$

Figure 4.11 and Table 4.9 represent the ratio of packets delivered with other routing approaches.

**Fig 4.11** Comparison of Packet delivery ratio

Table 4.9 Packet Delivery Ratio

Number of nodes -> (Approaches)	50	100	150	200	250	300
FMCB-ER	97.69241	96.69241	93.99797	91.30353	86.90908	84.60908
RFCM-ACO [175]	96.30353	95.30353	92.91464	90.52575	86.56313	83.1313
COARP [192]	94.8313	93.8313	91.74797	87.35908	86.27575	82.27575
TCBR [183]	93.05353	91.05353	87.97019	86.58813	84.49797	81.49797
LEACH [131]	90.97019	89.97019	84.88686	83.80353	82.41464	79.41464

The PDR is computed by running the simulation for 1000 rounds and computing the average of all the observation, and for different density of sensor nodes. It can be observed that proposed technique accomplishes up to 97.69% PDR for 50 SNs and about 84% for 300 nodes which is better than other compared techniques. The PDR is observed to be decreasing due to increase in node density and multihopping.

4.3.2.8 Number of alive nodes

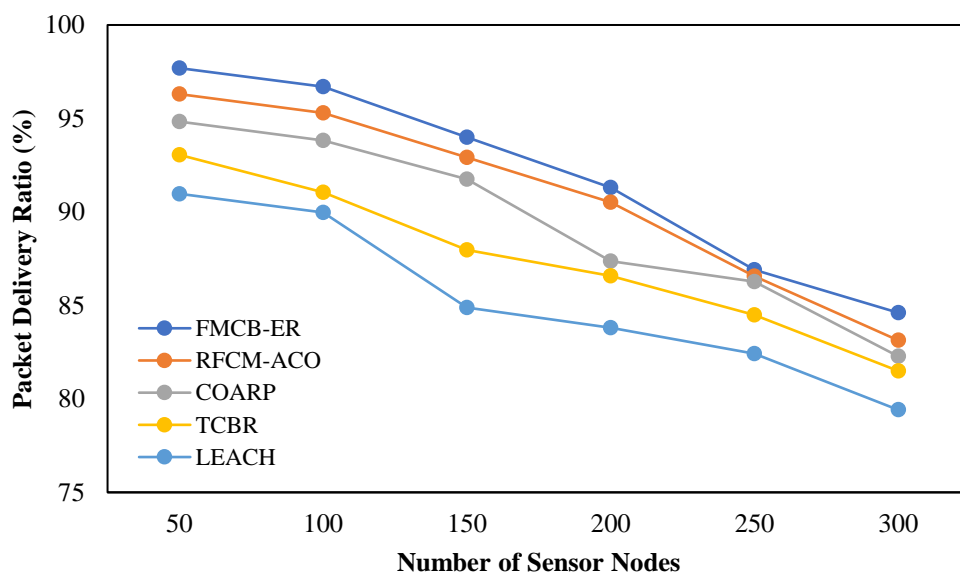
This parameter represents the SNs having adequate energy for processing intended tasks in network and is given by Eq. (4.48).

$$N_A^i = E_{Res}^i(n) > 0 \tag{4.48}$$

Here, residual energy of SN in i^{th} round is given by $E_{Res}(n)$. Figure 4.12 and Table 4.10 shows the number of alive SNs in the WSN for diverse compared approaches.

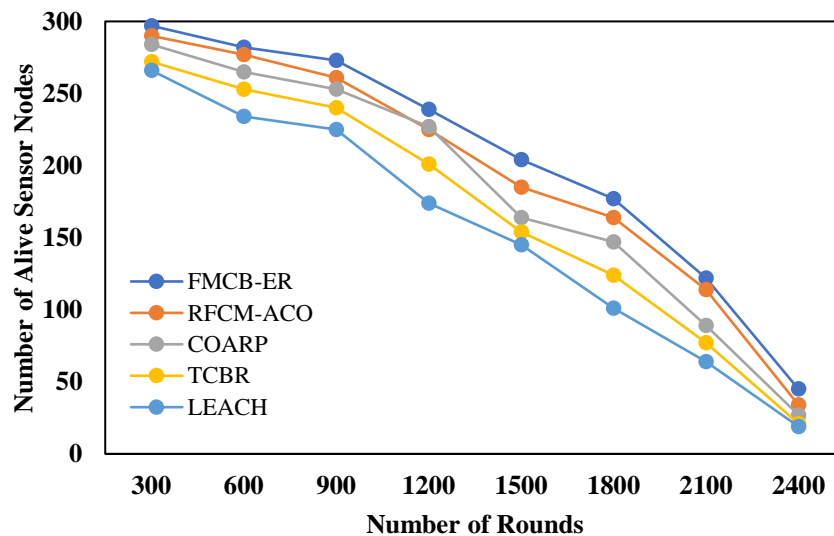

Fig 4.12 Comparison of Number of alive nodes

Table 4.10 Number of Alive Nodes

Number of rounds => (Approaches)	1000	1200	1400	1600	1800	2000	2200	2400
FMCB-ER	297	282	273	239	204	177	122	45
RFCM-ACO [175]	290	277	261	225	185	164	114	34
COARP [192]	284	265	253	227	164	147	89	27
TCBR [183]	272	253	240	201	154	124	77	21
LEACH [131]	266	234	225	174	145	101	64	19

As observed from Figure 4.12 and Table 4.10 that proposed FMCB-ER perform better than the compared approaches. FMCB-ER is able to complete 2400 rounds with 45 nodes still alive, whereas, for RFCM-ACO, COARP, TCBR and LEACH the number of alive sensor nodes are 34, 27, 21 and 19 respectively.

4.3.2.9 Number of dead nodes

This parameter represents the SNs in the WSN that do not have sufficient energy for their tasks and is given by Eq. (4.49).

$$N_D^i = E_{Res}^i(n) \leq 0 \tag{4.49}$$

Figure 4.13 and Table 4.11 represent the comparison of dead SNs in WSN while processing various tasks in different routing approaches. Table 4.11 depicts that for the same number of rounds, count of sensor nodes that die in compared approaches is higher due to high energy depletion during data transmission. As can be observed, after 2400 rounds 262 SNs die in case of FMCB-ER, whereas in case of LEACH and TCBR more than 275 SNs die for same number of rounds. Though COARP and RFCM-ACO do well with, 273 and 267 SNs dying respectively in 2400 rounds but is less than FMCB-ER.

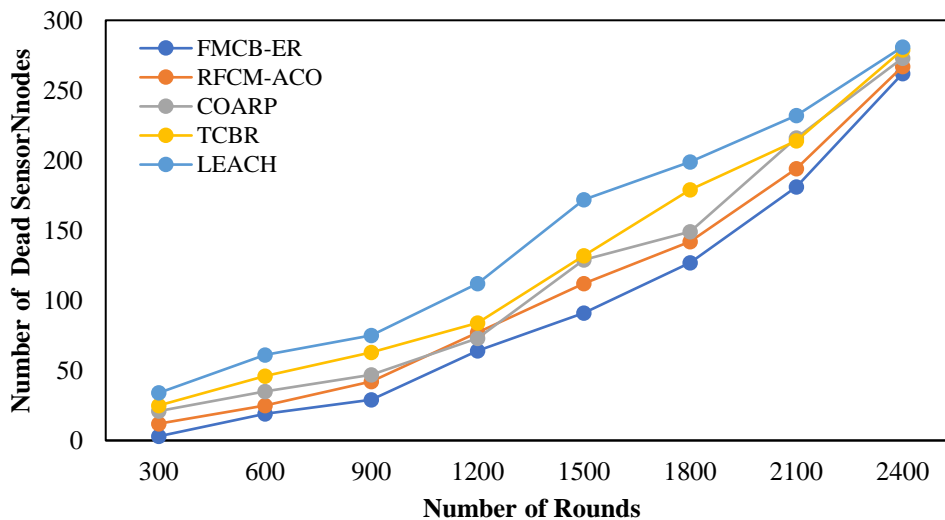

Fig 4.13 Comparison of Number of dead sensor nodes

Table 4.11 Number of Dead Nodes

Number of Rounds -> (Approaches)	1000	1200	1400	1600	1800	2000	2200	2400
FMCB-ER	3	19	29	64	91	127	181	262
RFCM-ACO [175]	12	25	42	77	112	142	194	267
COARP [192]	21	35	47	73	129	149	216	273
TCBR [183]	25	46	63	84	132	179	214	279
LEACH [131]	34	61	75	112	172	199	232	281

FMCB-ER avoids the complication of data aggregation using sink relocation thus preventing redundant data communication. When two nodes are within radius of each other, redundant data might be communicated to aggregator node that causes working load of the aggregator node to increase and hence unnecessary depletion of energy. Therefore, lifetime of aggregator node and other SNs is improved by minimizing data processing and communication of duplicate data.

4.4 Summary

Limited energy has always been a big challenge for WSNs as it affects their life. The energy efficient communication has always been an open challenge for researchers. Data communication is the prime source of energy consumption, and hence an energy-efficient routing protocol is required. The chapter, therefore, presented a new FMCB-ER, an energy-efficient routing protocol for data processing and transmission. The fuzzy-Analytic Hierarchy Process and Emperor Penguin Optimizer methods are used for it. The clusters are formed as a hierarchical grid, and the cluster head is selected with Fuzzy-AHP and TOPSIS method. Fuzzy-AHP allocates weight value for each node, and TOPSIS method ranks the cluster heads. After the selection of cluster heads, the routing process is initiated using EPO. The FMCB-ER is compared with various existing routing techniques such as LEACH, RFCM-ACO, COARP, and TCBR and the results are shown in Figure 4.5 to Figure 4.13. The comparison shows that FMCB-ER is comparatively better than compared.

Chapter 5

Multi-objective Based Cluster Head Selection and Energy Optimized Routing (MCH-EOR)

In heavy traffic conditions, sensors close to the sink node die early as they receive maximum data from other sensors in the WSN and thus cause energy-hole problems leading to a shorter lifespan of the whole WSN. Thus, the optimum utilization of existing energy is a challenge for applications supported by WSNs. In addition to energy, other quality of service (QoS) parameters such as proximity, communication cost, and coverage are also crucial for the overall effectiveness of a WSN. Therefore, a multi-objective approach, MCH-EOR², has been proposed in this chapter for the optimization of energy in sensor networks. MCH-EOR is a Multi-Objective Based Clustering and Sailfish Optimizer (SFO) steered routing approach. First, an effective multi-objective fitness function is generated, and CH is elected according to it. It minimizes energy consumption and reduces the number of dead sensor nodes. Second, the SailFish Optimizer algorithm is applied to select an optimal path to the sink node. Finally, MCH-EOR is systematically analysed and compared with the existing approaches called GWOEECR [190], Genetic Algorithm based approach called GASONEC [158], ALO based approach called SMEER [179] and PSO based approach called TPSO-CR [181] on the parameters of energy consumption, throughput, packet delivery ratio, and network lifetime.

5.1 MCH-EOR Protocol Description

The MCH-EOR design is divided into three main stages namely clustering, multi-objective-based CH selection, and SFO based route selection. Figure 5.1 depicts the complete process of MCH-EOR. The steps for MCH-EOR are as follows-

² The contents are published in Mehta, D., Saxena, S, "MCH-EOR: Multi-objective Cluster Head Based Energy-aware Optimized Routing algorithm in Wireless Sensor Networks," *Sustain. Comput. Informatics Syst.*, vol. 28, p. 100406, Dec. 2020, doi: 10.1016/j.suscom.2020.100406.

5.1.1 Network Setup

Here Sensor Network is considered to be multi-hop and is taken as a graph $G=\{P, Q\}$ with P representing a sink node or BS (see Figure 5.2) and Q represents transmission link among the sensor nodes. The assumptions for the network setup are as follows:

- For random sensor nodes' deployment, a two-dimensional Cartesian system is utilized.
- All the sensor nodes have a non-rechargeable battery.
- Sensor nodes are static and cannot change their location once deployed.
- The communication and processing capabilities of all the sensor nodes are identical.
- Initial energy of all the sensor nodes is equal.
- Transmission links among sensor nodes allow for bi-directional diffusion of data.

5.1.2 Energy Model

The protocol uses the energy model proposed in [48]. The transmitter spends energy on radio power amplifiers and electronics, while the receiver spends energy on radio electronics. Free space along with multipath fading channels is used as per distance between sender and receiver. In case of distance 'dis' between receiver and sender is less than a threshold distance, free space model is utilized, and in case of distance 'dis' is greater than threshold distance, multipath fading channel is applied. In case of free space model energy dissipation is square of the distance i.e., dis^2 and in case of multipath fading channel energy dissipation goes much higher to d^4 . Thus, for transmitting a k bit packet the energy consumption P_s is represented by Eq. (5.1).

$$P_s = \begin{cases} k * (P_{ec} + P_{frs} * dis^2) ; & dis < d_0 \\ k * (P_{ec} + P_{mpf} * dis^4) ; & dis \geq d_0 \end{cases} \quad (5.1)$$

The energy required to stimulate the electronic circuit of SN is given by P_{ec} . Distance between the sender and receiver and the tolerant bit error rate is utilized to identify amplifier energy of either free space or multi-path fading model $P_{frs} * dis^2$ or $P_{mpf} * dis^4$. P_{frs} and P_{mpf} depict required energy for sending a bit into free space through multipath fading channel respectively with d being distance between receiver and sender while dis_0 being threshold distance given by Eq. (5.2).

$$dis_0 = \sqrt{\frac{P_{frs}}{P_{mpf}}} \quad (5.2)$$

The energy consumed to receive a packet of k bits is given by Eq. (5.3),

$$P_{\text{rec}} = k * P_{\text{ec}} \quad (5.3)$$

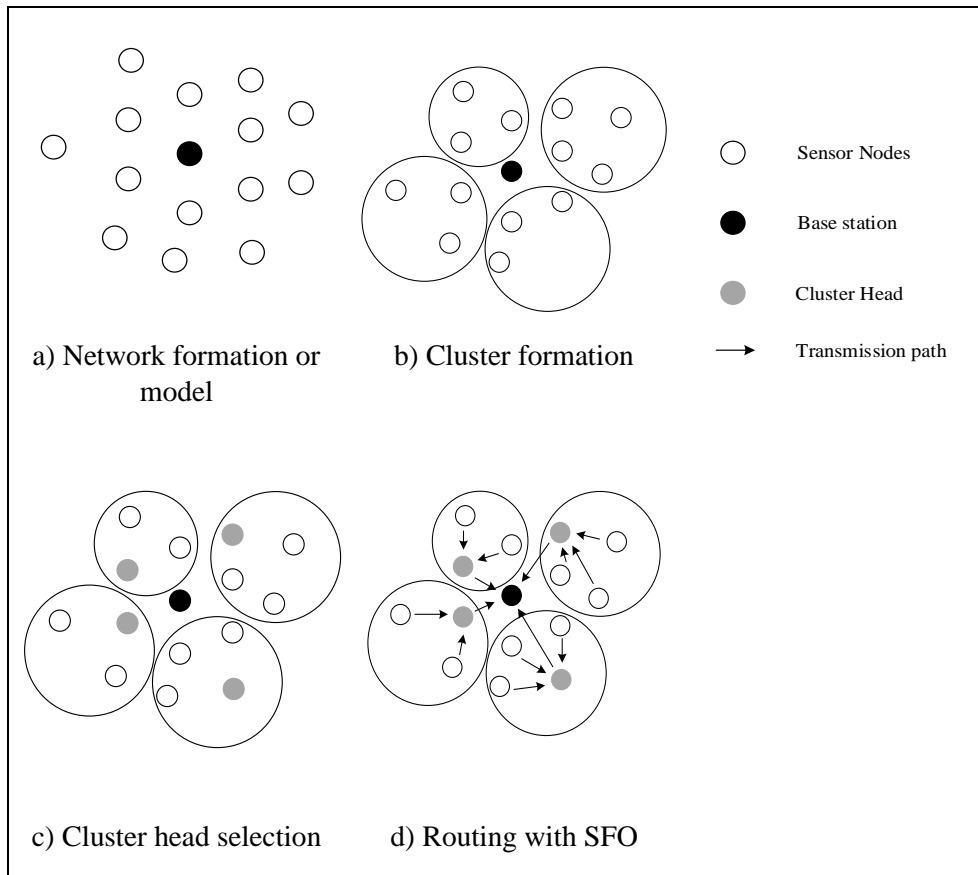

Fig. 5.1 Steps of MCH-EOR

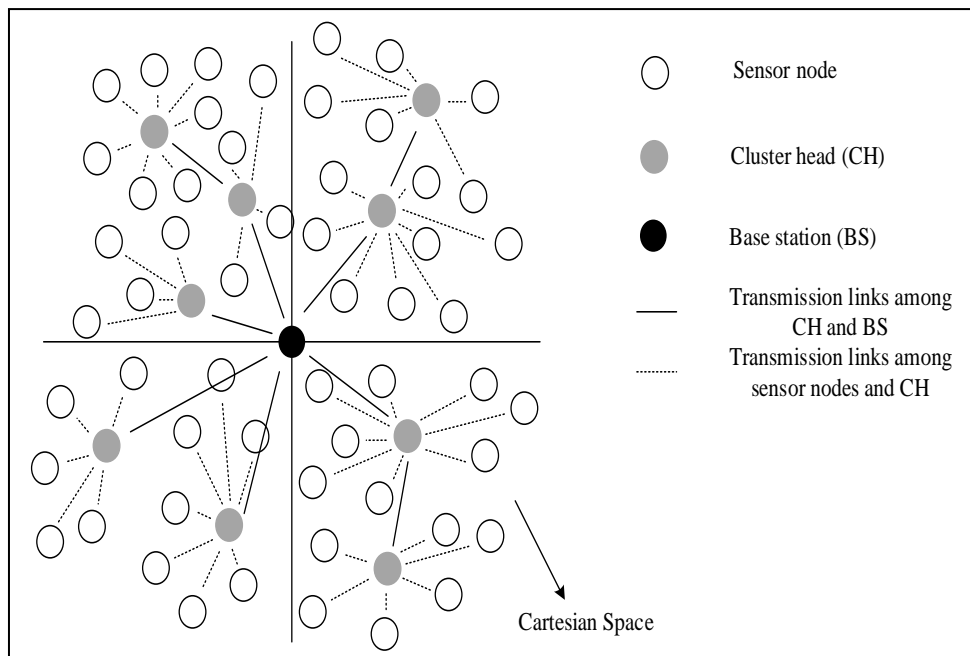

Fig. 5.2 Network structure of the proposed approach

The energy used by cluster head to aggregate the data is given by Eq. (5.4),

$$P_{agg} = P_{Eagg} * k * n \quad (5.4)$$

Here, " k ", represents the number of bits in a packet whereas " n ", represents the number of messages and P_{Eagg} gives the amount of energy to aggregate a bit.

5.2 Cluster Formation and Multi-Objective-Based CH Selection

Here, clusters are formed using unequal clustering approach [49], which has numerous benefits such as longer scalability, WSN lifespan, load balancing etc. This approach decreases the intra-cluster communication in the area near base station and averts the overload on sensor nodes near base station. Moreover, this formed cluster shall be recreated in case of node gets failure in the network due to energy depletion. Using this clustering approach, BS broadcasts the beacon message throughout the network, after node placement. SNs report their position by employing the GPS-Free Localization Algorithm [50] on receiving the message from sink. Also, sink estimates the upper range of network area keeping density of SNs, thus leading to coverage preservation. After this, lower range is evaluated by assessing energy utilization of sensor nodes before and after clustering. The cluster formation and process of election CH are discussed as follows:

5.2.1 Network Area Division

The parameters of sensor network like width (W_t) and height (H_t) determine the number of created layers N_L given by Eq. (5.5).

$$N_L = \left\lceil \frac{\sqrt{W_t * H_t * N}}{2(H_t + W_t)} \right\rceil + 1 \quad (5.5)$$

Here, N denotes number of nodes. Further, the initial layer, the number of sub-layers formed, and the clusters known as one of the nearest layers to the BS, denoted as N_{CL_1} represent the cluster and is given by Eq. (5.6):

$$N_{CL_1} = \frac{N}{\sqrt{2\pi}} \frac{E_{fs}}{E_{mpf}} \frac{M}{d^2 \text{ to } BS} \quad (5.6)$$

Here, M is the size of sensor network, ($d^2 \text{ to } BS$) is average square distance from all sensor nodes to the sink. The number of CH altered is given by Eq. (5.7).

$$N_{CL_i} = N_{CL_{i-1}} - 1, 2 \leq i \leq N_L \quad (5.7)$$

5.2.2 Clusters Creation

Initially, sensors need to identify nearby sensor nodes for creating clusters. The attribute activation flag, Layer ID, location of sensor node, Cluster ID, and Node ID are listed in the messages. For choosing the deactivating/activating sensor nodes and relay nodes or CH, both

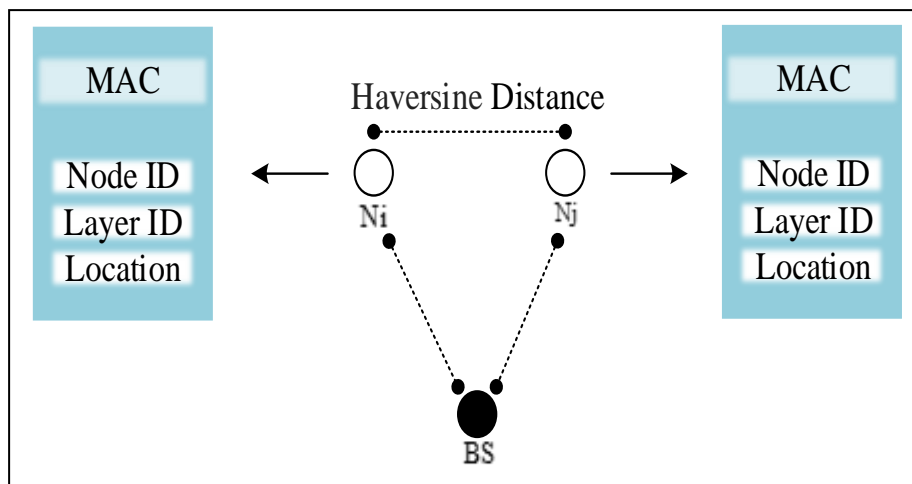

Fig. 5.3 Process of distance estimation with Haversine distance [51]

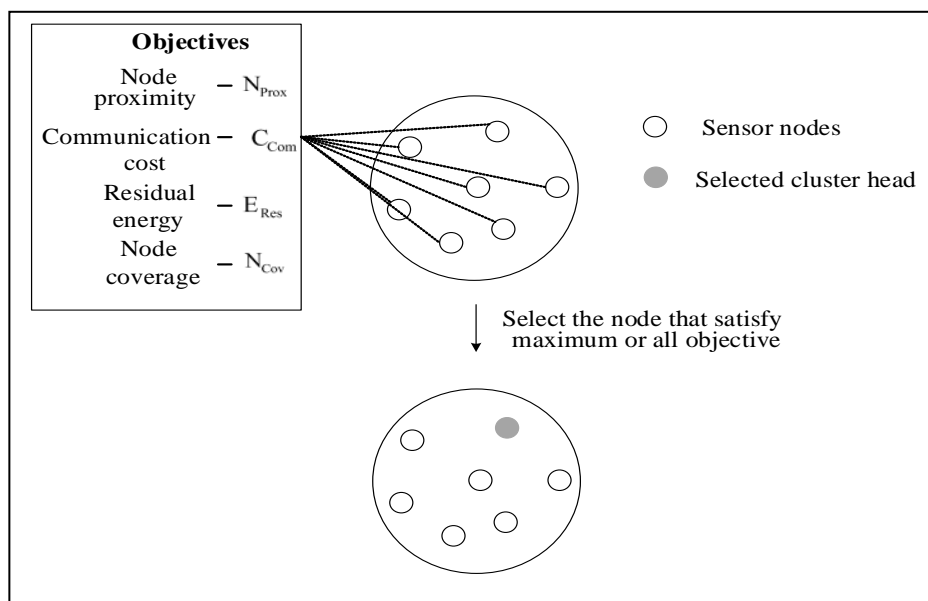

Fig. 5.4. CH selection based on different objectives

activation flag and node are required. Here, the Haversine distance (*see* Figure 5.3) formula [51] is utilized to estimate the distance given by Eq. (5.8).

$$\text{Diff}_{\text{Nodes}} = \text{Loc}_{N_i} - \text{Loc}_{N_j} \quad (5.8)$$

Here, Loc_{N_i} and Loc_{N_j} indicate the locations of two nodes respectively. The difference among the sensor nodes and the base station is given by Eq. (5.9),

$$Diff_{NBS} = Loc_{N_i} - Loc_{BS} \quad (5.9)$$

Where, Loc_{BS} depicts the location of the base station. The adjacent node is found by the distance given by Eq. (5.10).

$$Dis = \sin\left(\frac{Diff_{Nodes}}{2}\right)^2 + \cos(Loc_{N_j}) * \cos(Loc_{N_i}) * \left(\sin\left(\frac{Diff_{NBS}}{2}\right)\right)^2 \quad (5.10)$$

In case, a sensor node is unavailable or dies, cluster formation process will get initiated again.

5.2.3 Cluster Head Selection

Sensor nodes other than CH in the network utilize energy for the processes such as data collection, transmission, and reception. At the same time, cluster heads perform activities such as data aggregation, transmission, and reception of data from these sensor nodes. Arguably CHs consume maximum energy in comparison to other sensor nodes. Thus, these CHs need more energy for processing their intended tasks. Therefore, an efficient CH selection process is desirable. A probabilistic approach is used to select the best CH keeping multiple objectives like communication cost, proximity, residual energy, and coverage into consideration. For this, a multi-objective CH selection process is followed and is depicted in Figure 5.4.

Objective 1: Proximity

To begin with, the protocol finds the proximity of neighbouring nodes according to their distance by Eq. (5.11) and the attained objective is given by Eq. (5.12).

$$N_{Prox} = \frac{1}{N_T} \sum_{i=1}^{1-N_T} d(n,i) \quad (5.11)$$

$$\text{Minimize } F_1 = \frac{1}{N_T} \sum_{i=1}^N N_{Prox}(N_i) \quad (5.12)$$

Here N_T gives the total number of sensor nodes in a network and $d(n, i)$ denotes distance among the sensor node and its neighbour.

Objective 2: Communication cost

The cost to communicate with the neighbour node is estimated by Eq. (5.13) subjective to the objective shown in Eq. (5.14).

$$C_{Com} = \frac{d_{Avg}^2}{d_0^2} \quad (5.13)$$

$$\text{Minimize } F_2 = \frac{1}{N_T} \sum_{i=1}^N C_{com}(N_i) \quad (5.14)$$

Here d_{Avg}^2 denotes the average distance among the node and neighbour whereas d_0^2 shows the radius of nodes.

Objective 3: Residual energy

Estimation of residual energy of a SN is performed using Eq. (5.15) and subjective to the objective function given in Eq. (5.15).

$$E_{Res} = E_T - (E_{Coll} + E_{Tran} + E_{Rec} + E_{Agg}) \quad (5.15)$$

$$\text{Maximize } F_3 = \frac{1}{N_T} \sum_{i=1}^N E_{Res}(N_i) \quad (5.16)$$

Here, E_T , depicts total energy of a sensor node, E_{Coll} is energy utilized in data collection, E_{Tran} is energy utilized for data transmission, E_{Rec} is the energy utilized to receive data and E_{Agg} is the energy utilized to aggregating the data.

Objective 4: Coverage

The coverage of sensor node is determined by Eq. (5.17) subjective to the objective function given in Eq. (5.18).

$$N_{Cov} = r(N_i) \quad (5.17)$$

$$\text{Maximize } F_4 = \frac{1}{N_T} \sum_{i=1}^N N_{cov}(N_i) \quad (5.18)$$

Here, $r(N_i)$ presents the radius covered by the node in network. Fitness function has been developed in a manner that a trade-off can be achieved among stated objectives. A multi-objective fitness function is developed with Weighted Sum Approach (WSA). For every objective, the weight value W_i is multiplied to this objective value and different objectives are transformed into a single scalar objective function by adding them.

$$\text{Fitness} = W_1 \times F_1 + W_2 \times F_2 + W_3 \times F_3 + W_4 \times F_4 \quad (5.19)$$

$$\text{i.e., Fitness} = W_1 \times \frac{1}{N_T} \sum_{i=1}^N N_{Prox}(N_i) + W_2 \times \frac{1}{N_T} \sum_{i=1}^N C_{com}(N_i) + W_3 \times$$

$$\frac{1}{N_T} \sum_{i=1}^N E_{Res}(N_i) + W_4 \times \frac{1}{N_T} \sum_{i=1}^N N_{cov}(N_i) \quad (5.20)$$

We take $W_1 + W_2 + W_3 + W_4 = 1$ and, $0 \leq W_i \leq 1, \forall i, 1 \leq i \leq 4$. Here, the main objective is to maximize the value of fitness given by Eq. 5.21

$$\text{Objective: Maximize Fitness} \quad (5.21)$$

The node that satisfies all these objectives shall be elected as a cluster head. The elected CH in every cluster is responsible for aggregating and forwarding the packets to BS directly or through multi-hops. After CH election in every cluster, the route shall be identified to transmit aggregated data to the BS.

Algorithm 5.1 Multi-objective-based cluster head selection algorithm

Input: Set of Sensor Nodes $S = \{s_1, s_2, s_n\}$
Output: Selection of best sensor node as cluster head

1. **Begin**
2. **For** $i = 1; i \leq n; i++$
3. **While** (Selecting the Cluster Head)
4. **For** each cluster sensor node s_i (Evaluate multiple objectives)
 - Calculate proximity $N_{\text{Prox}} = \frac{1}{N_T} \sum_{i=1}^{1-N_T} d(n,i)$
 - If** (N_{Prox} is minimum)
 - Select sensor node s_i
 - else**
 - Reject sensor node s_i
 - Calculate communication cost $C_{\text{Com}} = \frac{d_{\text{Avg}}^2}{d_0^2}$
 - If** (C_{com} is minimum)
 - Select sensor node s_i
 - else**
 - Reject sensor node s_i
 - Calculate residual energy
 - $E_{\text{Res}} = E_T - (E_{\text{Coll}} + E_{\text{Tran}} + E_{\text{Rec}} + E_{\text{Agg}})$
 - If** (E_{Res} is maximum)
 - Select sensor node s_i
 - else**
 - Reject sensor node s_i
 - Calculate coverage $N_{\text{Cov}} = r(N_i)$
 - If** (N_{Cov} is maximum)
 - Select sensor node s_i
 - else**
 - Reject sensor node s_i
 - Choose s_i which maximizes the fitness
 - 5. **End For**
 - 6. **End While**
 - 7. **End**

5.3 Path Optimization through Sailfish Optimizer Algorithm

Sailfish Optimizer is a metaheuristic algorithm based on population. In search space, the position of sailfish is termed as the problem's variable; similarly, the solutions of a candidate are taken as sailfish. Generation of the population in the space of solutions occurs randomly. According to vectors position, the performance of searching of sailfish can happen in hyper/three, two, one-dimensional space. The current position $SF_i \in \mathbb{R}$ ($i = 1, 2, \dots, m$) of i^{th} member located at the bout of k^{th} searching. Locations of every single sailfish is given in the below matrix.

$$SF_{\text{position}} = \begin{bmatrix} SF_{1,1} & SF_{1,2} & \cdots & SF_{1,n} \\ SF_{2,1} & SF_{2,2} & \cdots & SF_{2,n} \\ \vdots & \vdots & \vdots & \vdots \\ SF_{d,1} & SF_{d,2} & \cdots & SF_{d,n} \end{bmatrix} \quad (5.22)$$

While updating the search agents' position, the most acceptable solution may have been missed. So, while comparing with old positions, updated positions may be less in strength; thus, the process of elitism is required. On carrying out the elitism, the unaltered fittest solution(s) are used. The fitness of elite proceeded sailfish is high, and also, at the time of the attack, it has a high ability to create a negative influence on the acceleration and manoeuvrability of the sardines. In the i^{th} iteration, the fitness of both injured sardine and elite sailfish positions goes high and is given as $injured_S$ and X_{elite_SF} , respectively. These positions can influence the working of SFO; moreover, the time needed to re-discover the solutions is also reduced.

5.3.1 Attack-Alternation Strategy

In general, the success rate of hunting by Sailfish is high, with most of the hunting is carried out through temporary coordination. Sailfish change their site as per the site of other hunters near prey school. After sailfish attacks in groups, the attack's alternation strategy is validated by the SFO algorithm. These Sailfish can attack in all directions within a shrinking circle. Thus, location of Sailfish altered concerning most acceptable solution present in that shrinking circle is considered as the new position of Sailfish which is given by Eq. (5.23).

$$X_{new_SF}^i = X_{elite_SF}^i - \lambda_1 \times (\text{round}(0, 1) \times \left\{ \frac{X_{elite_SF}^i + X_{injured_S}^i}{2} \right\} - X_{old_SF}^i) \quad (5.23)$$

5.3.2 Hunting and Catching the Prey

The energy of a sailfish is higher at the starting of the hunting operation, in which the sardines have no injuries and are not tired. So, sardines can move quickly and escape easily. On the other hand, sardine updates its power and position as per the movement and position of the Sailfish. At the i^{th} iteration, the sardine got a new position as X_{inew_S} as in Eq. (5.24)

$$X_{inew_S} = r \times (X_{eliteSF} - X_{oldS} + AP) \quad (5.24)$$

The position of both sardines, as well as sailfish, is created randomly in the SFO algorithm. As per the elite sailfish and status of injury of injured sardine, the update of each sailfish is achieved. Usually, the sailfish accomplishes sardine position in a single iteration. After completing the position updating of each sardine and sailfish, the objective function evaluates their position. Similarly, in every step of the algorithm, the position of injured sardine and elite sailfish diverges. The hunted sardine is removed last, and these steps are repeated until accomplishing the requirement.

5.4 Data Forwarding to BS

Here, the process of transmitting the aggregated data on each CH to the BS is described. To find the optimal path available to transmit data on the network, the SailFish Optimizer algorithm is applied. The SFO based routing process contains three steps of Initialization, Path selection, Data transmission and Path alteration and are discussed below.

5.4.1 Initialization

SailFish Optimizer can search the solutions in hyper dimension according to its position vectors. Thus, SFO needs population as well as all the paths available from the cluster head to the BS. In the 2-D Cartesian space, i^{th} cluster head has its own positions $CH_{i,k} \in k (i = 1,2,3,\dots,n)$ in path k . The position of every cluster head in the paths is stored in a matrix shown in Eq. (5.25),

$$CH_{pos} = \begin{bmatrix} CH_{1,1} & CH_{1,2} & \cdots & CH_{1,n} \\ CH_{2,1} & CH_{2,2} & \cdots & CH_{2,n} \\ \vdots & \vdots & \vdots & \vdots \\ CH_{d,1} & CH_{d,2} & \cdots & CH_{d,n} \end{bmatrix} \quad (5.25)$$

Here, n gives the number of CHs and d depicts number of paths and the dimension of i^{th} cluster head is shown with $CH_{i,j}$. Fitness of every cluster head in all paths is assessed using fitness function defined by Eq. (5.26),

$$\text{fitness value of CH} = f(\text{CH}) \quad (5.26)$$

Here, three objectives specifically energy, link quality, and throughput have been taken into consideration to avoid the sensor node failure and traffic control. Throughput of CH is estimated by Eq. (5.27),

$$\text{Th} = \sum_{i=1}^n \text{CH}_i [DS_{\text{CH}_i}(\text{Loc}_{\text{CH}_i}, \text{Loc}_{\text{BS}})] \quad (5.27)$$

Here, the data transmission speed of CH is given by DS_{CH_i} , and the location of CH and sink is shown as $(\text{Loc}_{\text{CH}_i}, \text{Loc}_{\text{BS}})$. The energy of CH is estimated by Eq. (5.15). Energy of cluster heads in the path is assessed rather than estimating energy of sensor nodes. The quality of the link is estimated as per Received Signal Strength (RSS) [52] received from the adjacent cluster head and is given by Eq. (5.28),

$$\text{Link}_Q = \begin{cases} \text{Very good,} & \text{if RSS} < -10 \text{ dBm} \\ \text{Good,} & \text{if RSS} < -20 \text{ dBm} \\ \text{Bad,} & \text{if RSS} < -40 \text{ dBm} \\ \text{Very Bad} & \text{if RSS} < -60 \text{ dBm} \end{cases} \quad (5.28)$$

The fitness value of cluster head is assessed with Eq. (5.29),

$$f(\text{CH}) = W_1 \times \text{Th} + W_2 \times E_{\text{Res}} + W_3 + \text{Link}_Q \quad (5.29)$$

Here, W indicates the weight factor with its value lying between 0 and 1. The fitness value of CHs in every path is stored in the form of a matrix given by Eq. (5.30),

$$\text{CH}_{\text{fit}} = \begin{bmatrix} f(\text{CH}_{1,1}) & \text{CH}_{1,2} & \cdots & \text{CH}_{1,n} \\ f(\text{CH}_{2,1}) & \text{CH}_{2,2} & \cdots & \text{CH}_{2,n} \\ \vdots & \vdots & \ddots & \vdots \\ f(\text{CH}_{d,1}) & \text{CH}_{d,2} & \cdots & \text{CH}_{d,n} \end{bmatrix} \quad (5.30)$$

The position of BS is given by Eq. 5.31,

$$\text{BS}_{\text{pos}} = \text{Loc}_{\text{BS}} \quad (5.31)$$

Here, Loc_{BS} shows location of the sink and is set at the dimension (0, 0) in the deployed Cartesian space.

5.4.2 Path Selection Strategy

Selection of path is done by identifying the best adjacent CH as per its fitness value. The identified best adjacent CH, CH_i^{elite} will be updated with other CHs, $X_{CH_{old}}^i$ to identify the best path and is shown in Eq. (5.32),

$$P_{best} = CH_i^{elite} - \lambda_i \times \left(r \times \left(\frac{CH_i^{elite} + BS_{pos}}{2} \right) + X_{CH_{old}}^i \right) \quad (5.32)$$

Where CH_i^{elite} gives the position of newly found cluster leader. The position of CHs already recognized as best and initial cluster head is given by $X_{CH_{old}}^i$, whereas, r depicts the random number lying between 0 and 1. The λ_i is the co-efficient at i^{th} iteration and is generated using Eq. (5.33),

$$\lambda_i = 2 \times r \times PD \quad (5.33)$$

Where, PD gives the current path density and is defined depending on the number of currently available hops. It is given with Eq. (5.34),

$$PD = \left(\frac{N_{CHs}}{N_{CHs} + N_{BS}} \right) \quad (5.34)$$

Here, the number of cluster leaders and sink is presented by N_{CHs} and N_{BS} . Because the network has only one BS, value of N_{BS} is fixed to 1.

5.4.3 Data Communication and Path Alteration

After the best path is identified among multiple paths, the process to communicate the data is initiated. During data transmission, energy for transmission of data packets to the BS is consumed, which may cause a reduction in its energy, or even cluster head may die. Keeping this into consideration, the algorithm periodically monitors the path before initiating the data transmission in each iteration. If any node cannot communicate data, it shall be removed from the path, and an alternate path is selected. The path alteration is to be carried out using Eq. (5.35),

$$P_{alt} = \text{New_}P_{best} \quad \text{if } E_{Res}(CH_i) < \text{min threshold} \quad (5.35)$$

Using Eq. (5.32), the new best path will be identified from the available paths in case the energy of any CH is less than minimum threshold and is given by $E_{Res}(CH_i) < \text{min threshold}$. Where, $\text{min threshold} = E_{need}(CH_i, CH_j)$. Energy needed to transmit the

data from location of one cluster head to next one in the path is given by $E_{need}(CH_i, CH_j)$. The process of SFO based routing is shown in Figure 5.5 and in Algorithm 5.2. The complete process of MCH-EOR is presented in Algorithm 5.3. The MCH-EOR, therefore, creates optimal clusters and selects effective CH and leads to minimizing coverage holes and enhances the network lifetime. The creation of the clusters inside the network area by unequal clustering based on the density of SNs, reduces the probability of making void clusters in the network that maximizes coverage and connectivity necessary for successful data forwarding.

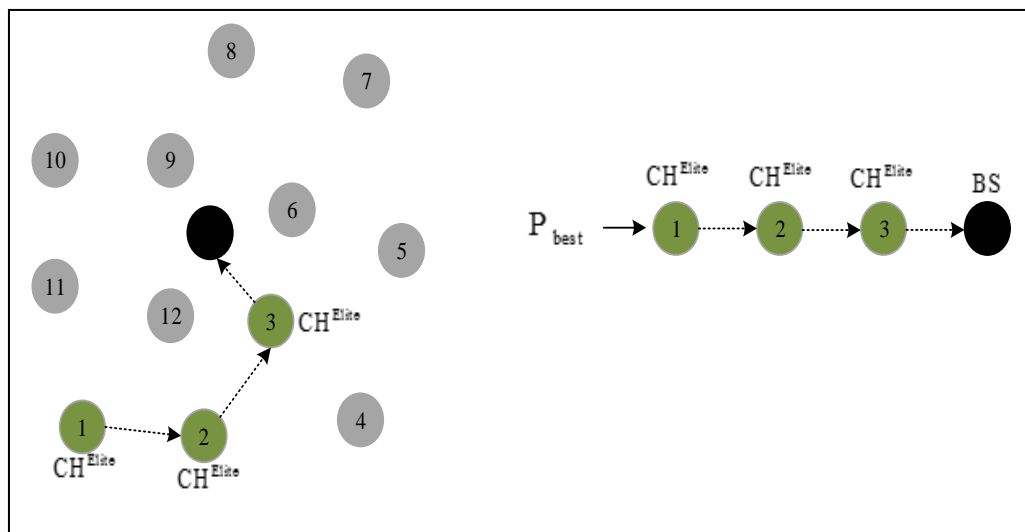

a) Process of path selection

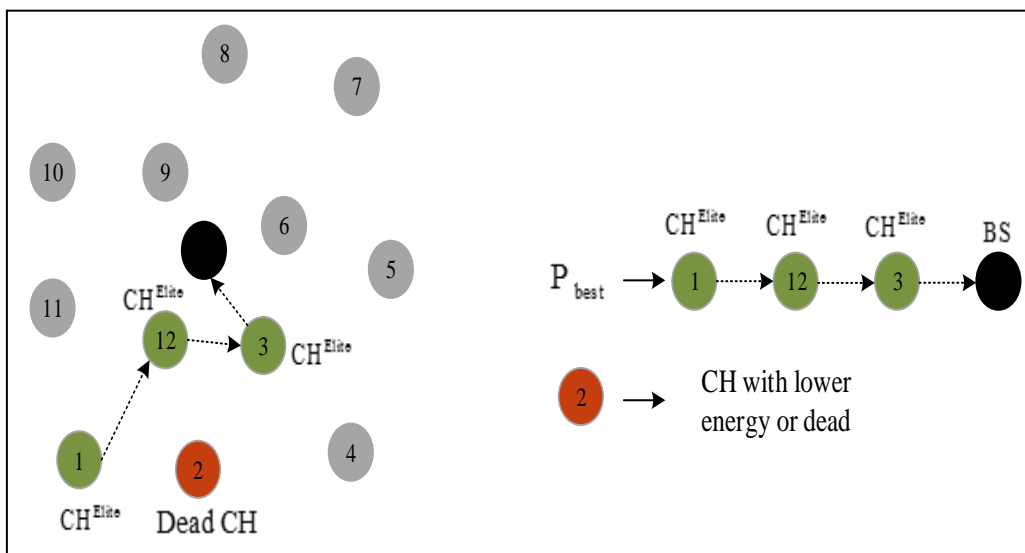

b) Process of path alteration

Fig. 5.5 a) Path selection, b) Path alteration, and forwarding data to BS with SFO

Algorithm 5.2 SFO based routing algorithm

Input: Number of possible paths for routing to BS

Output: Optimal routing path to BS

1. **Begin**
2. Initialize the CHs positions and BS position. Initialize SFO parameters
3. Evaluate the fitness of CHs to become a route forwarder.
4. **While** termination condition not satisfied.
For each CH
 Calculate throughput of CH_i.
 If (throughput is High)
 Select cluster head node CH_i for data forwarding
 else
 Reject cluster head node CH_i
 If (link quality is Good)
 Select cluster head node CH_i for data forwarding
 else
 Reject cluster head node CH_i
 If (node energy is High)
 Select cluster head node CH_i for data forwarding
 else
 Reject cluster head node CH_i
End For
 If best path identified
 Update the best path as data forwarding path.
 else
 Repeat the route selection process.
5. **If** capability of any CH is low
6. Execute the alternate path selection process and update the best path.
7. **End If**
8. **End While**
9. Return best optimal path
10. **End**

Algorithm 5.3 Overall algorithm of the proposed routing

Input: Set of sensor nodes $S = \{S_1, S_2, \dots, S_n\}$

Output: Optimized path for data forwarding

1. **Begin**
 2. Initialize randomly deployed nodes, $N = 1$ to n .
 3. Initialize Node ID and Layer ID of all nodes in MAC.
 4. Select two nodes from the network randomly, N_i and N_j .
 5. **For** nodes N_i and N_j do,
 Calculate location difference from node N_i to node N_j ,
 $\text{Diff}_{\text{Nodes}}$.
 Calculate difference from node N_i to BS, Diff_{NBS} .
 6. **End For**
-

-
7. Find the adjacent node of the sensor node
 8. **Repeat** steps 4 to 6 until forming a cluster for all the nodes.
 9. Select the best CH for every cluster using algorithm 1.
 10. Select the optimized path by using algorithm 2.
 11. Return the optimized path.
 12. **End**
-

5.5 MCH-EOR Performance Evaluation and Results Analysis

The performance evaluation of MCH-EOR is done in comparison with the similar routing approaches like GWOEECR [190], GASONEC [158], SMEER [179] and TPSO-CR [181] on various parameters of performance evaluation including WSN lifespan, energy consumption, number of alive and dead SNs, packet delivery ratio and throughput.

5.5.1 Simulation Parameters

The simulation is performed on different number of sensor nodes varying between 100 and 500 with each sensor node carrying an initial energy of 2J. Packet size considered is 10000 bits with simulation being executed for a maximum of 3500 rounds. The details of employed parameters are shown in Table 5.1.

Table 5.1 Parameters and values utilized during simulation

Parameter	Used values
Deployment area	200 m × 200 m
Nodes	100 – 500
Clusters	Differs
Initial node energy	2 J
Initial network energy	Varies based on the number of nodes
Packet size	10000 bits
Max network throughput	1 Mbps
Sink location	(0, 0)
Range of nodes	30 – 40 m
Max number of Rounds	3500

5.5.2 Simulation Results

The MCH-EOR simulation results are as follows:

5.5.2.1. Network lifetime

Network lifetime is defined as the time duration or rounds for which the network can complete its operations and is given by Eq. (5.36).

$$\text{Network lifetime} = \min_j \left[\frac{\sum_{i=1} CM_{ij} * L_i}{N_j} \right] \quad (5.36)$$

Here, CM_{ij} gives coverage matrix, L_i depicts lifetime of sensor node, whereas N_j represents the number of nodes in k coverage. The coverage matrix CM_{ij} is given by Eq. (5.37),

$$CM_{ij} = \begin{cases} 1 & \text{if } SN_i \text{ monitors } Tar_j \\ 0 & \text{Otherwise} \end{cases} \quad (5.37)$$

Where, SN_i represents the sensor node and Tar_j shows target whereas L_i presents the life of sensor node and is given by Eq. (5.38),

$$L_i = \frac{E_0}{EC_i}, 1 \leq i \quad (5.38)$$

Here E_0 and EC_i represent the initial energy of sensor nodes and energy consumption rate of sensor nodes respectively.

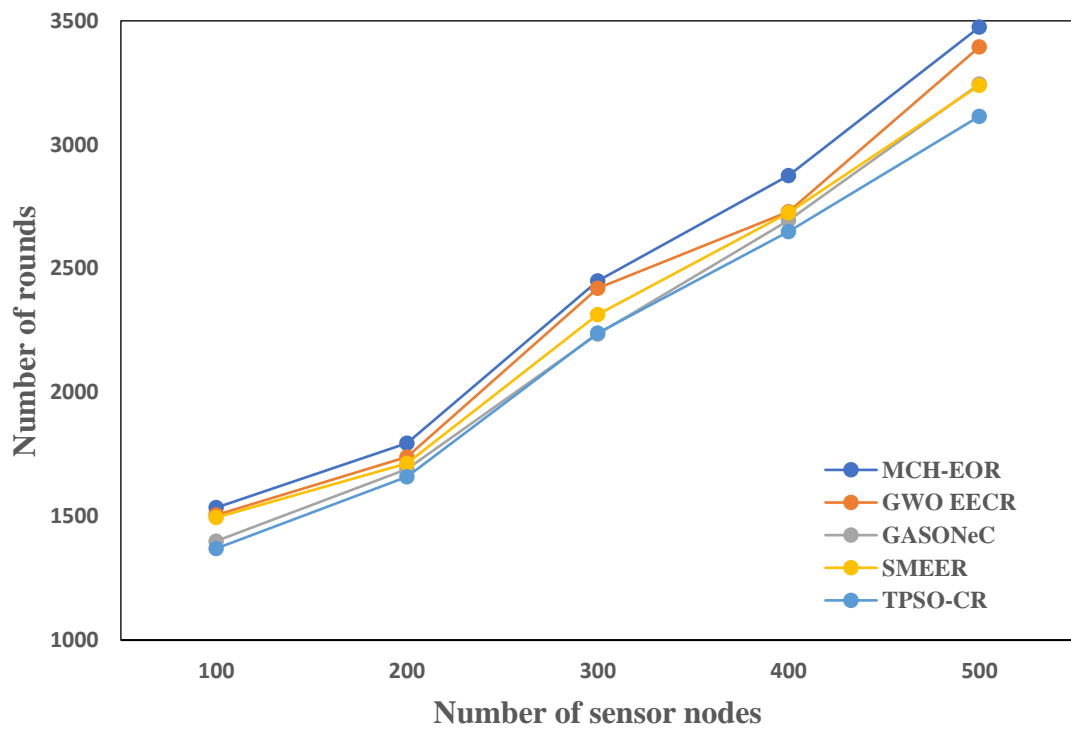

Fig. 5.6 Network lifetime

Figure 5.6 and Table 5.2, depicts the comparison of the WSN lifespan of MCH-EOR with compared optimization-based routing approaches. As can be observed from Figure 5.6, that MCH-EOR can sustain for about 1535 rounds with 100 nodes and can sustain for

almost 3475 rounds with 500 nodes which is comparatively higher than other protocols. The GWOEECR protocol is near to the MCH-EOR and sustain for 1505 rounds for 100

Table 5.2 Network lifetime (in rounds)

Number of Nodes ->	100	200	300	400	500
(Approaches)					
MCH-EOR	1535	1795	2450	2875	3475
GWOEECR [190]	1505	1740	2420	2730	3395
GASONeC [158]	1400	1690	2236	2695	3245
SMEER [179]	1495	1714	2315	2725	3240
TPSO-CR [181]	1370	1660	2240	2650	3115

nodes while GASONeC, SMEER and TPSO-CR sustain for 1400, 1495 and 1370 rounds respectively. For the dense node of 500 nodes the MCH-EOR sustain for 3475 rounds while GASONeC, SMEER and TPSO-CR sustain for 3395, 3245, 3240 and 3115 rounds respectively. A marginal difference is observed for 200 nodes because the node density increases from 100 to 200 and the availability of multi-path exists. This simply reduces the energy consumption. As the density increases from 200 to 300, 400 and 500 the behaviour of the protocols changes due to the approach and the functionality defined in their working.

5.5.2.2 Number of Alive Nodes

This parameter represents the number of sensor nodes in the WSN having adequate energy for processing their tasks and is given by Eq. (5.39).

$$N_A^i = E_{Res}^i(n) > 0 \quad (5.39)$$

Where, remaining energy of node in i^{th} round is given by $E_{Res}(n)$. Figure 5.7 and Table 5.3 shows comparison of number of alive nodes in the network for proposed approach and other compared approaches.

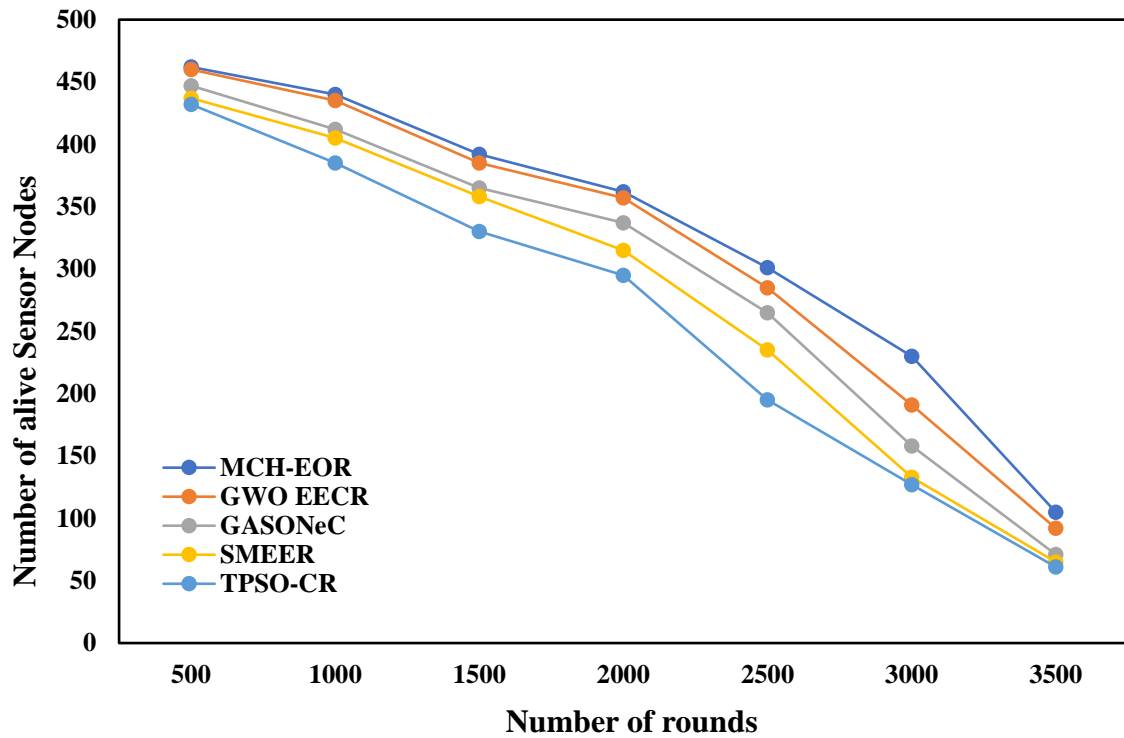

Fig. 5.7 Comparison of alive nodes of MCH-EOR with compared routing techniques

Table 5.3 Number of alive Sensor Nodes

Number of Rounds ->	500	1000	1500	2000	2500	3000	3500
(Approaches)							
MCH-EOR	462	440	392	362	301	230	105
GWOEECR [190]	460	435	385	357	285	191	92
GASONeC [158]	447	412	365	337	265	158	71
SMEER [179]	437	405	358	315	235	133	65
TPSO-CR [181]	432	385	330	295	195	127	61

It is evident from Figure 5.7 and Table 5.3 that the MCH-EOR perform better in comparison to GWOEECR, GASONeC, SMEER and TPSO-CR. The comparison is set for 500 sensor nodes initially and all the compared protocols are allowed to run for different rounds. As the number of rounds increases from 500 to 3500 (max) the nodes in the topology start dying. After completion of each round the topology is allowed to adjust as per their deployment algorithm. In MCH-EOR, GWOEECR, GASONeC, SMEER and TPSO-CR observes 38, 40, 53, 63 and 68 dead nodes respectively for initial 500 rounds. This gap increases to 395, 408, 429, 435 and 439 respectively for 3500 rounds. Overall MCH-EOR

has 21%, GWO App. has 18.4%, GASONeC has 14.2%, SMEER has 13% and TPSO-CR has 12.2% alive node after completion of 3500 rounds.

5.5.2.3 Number of Dead Nodes

This parameter represents the number of sensor nodes in the network who does not have adequate energy to conduct their intended tasks and is given by Eq. (5.40). The sensor node deployment of 500 nodes is done for the result comparison and all the protocols are allowed to run for different rounds varying from 500 to 3500. After completion of each round the topology is allowed to reset as per their algorithms. Figure 5.8 and Table 5.4, depicts the comparison of count of dead sensor nodes in the WSN with other compared approaches while processing a set of rounds.

$$N_D^i = E_{Res}^i(n) \leq 0 \quad (5.40)$$

Figure 5.8 depicts that sensor node starts dying during processing of their intended tasks including data transmission. In case of MCH-EOR routing approach, approximately 38 sensor nodes die after processing 500 rounds however for other approaches it is 40, 53, 63 and 68. After completing 3500 rounds, number of SNs that dies in MCH-EOR is 395

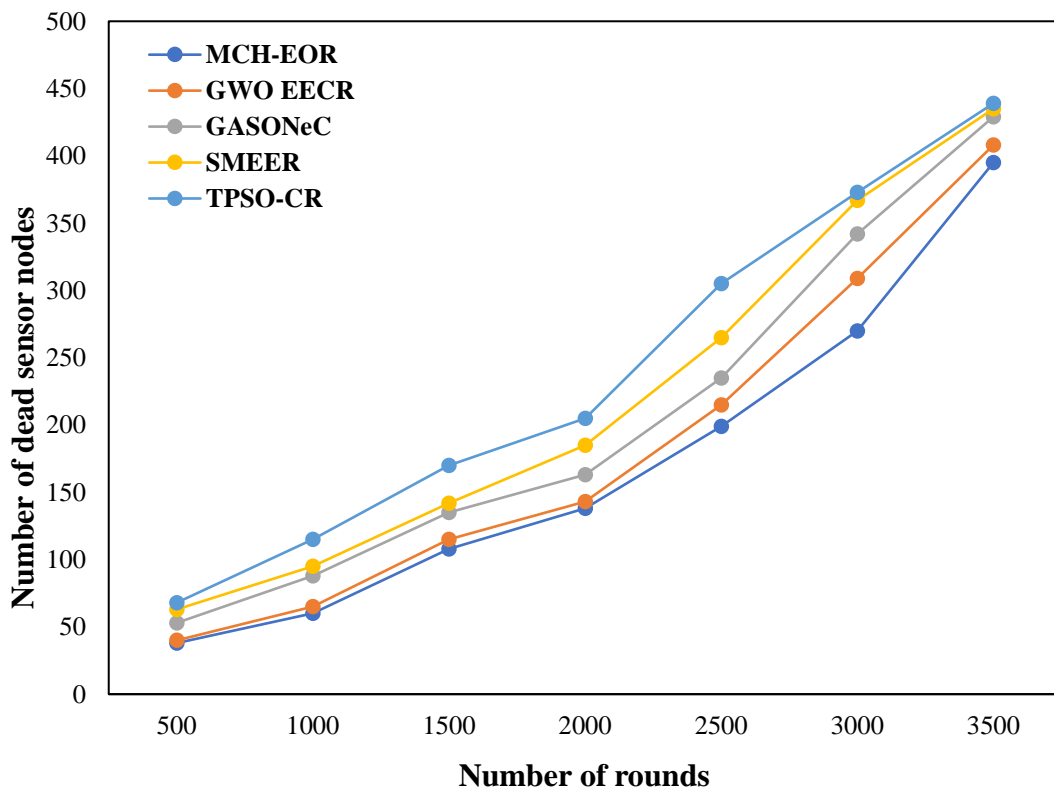

Fig. 5.8 Comparison of dead nodes

Table 5.4 Number of dead Sensor Nodes

Number of Rounds -> (Approaches)	500	1000	1500	2000	2500	3000	3500
MCH-EOR	38	60	108	138	199	270	395
GWOEECR [190]	40	65	115	143	215	309	408
GASONEC [158]	53	88	135	163	235	342	429
SMEER [179]	63	95	142	185	265	367	435
TPSO-CR [181]	68	115	170	205	305	373	439

whereas 408, 429, 435 and 439 nodes die in case of GWO App., GASONEC, SMEER, and TPSO-CR approaches respectively. After completion of 3500 rounds the MCH-EOR has 79% dead nodes, 81.6% in GWO App, 85.8% in GASONEC, 87% in case of SMEER and 87.8% in TPSO-CR which indicate the good performance of MCH-EOR.

5.5.2.4 Energy Consumption

Energy consumption signifies the amount of energy consumed by the SNs in the WSN and is represented by Eq. (5.41).

$$\text{Energy Consumption} = [\sum_{n=1} CH_E(n) + \sum_{m=1} CM_E(m)] \quad (5.41)$$

Here, $CH_E(n)$ represents the energy utilized by cluster head whereas $CM_E(m)$ represents.

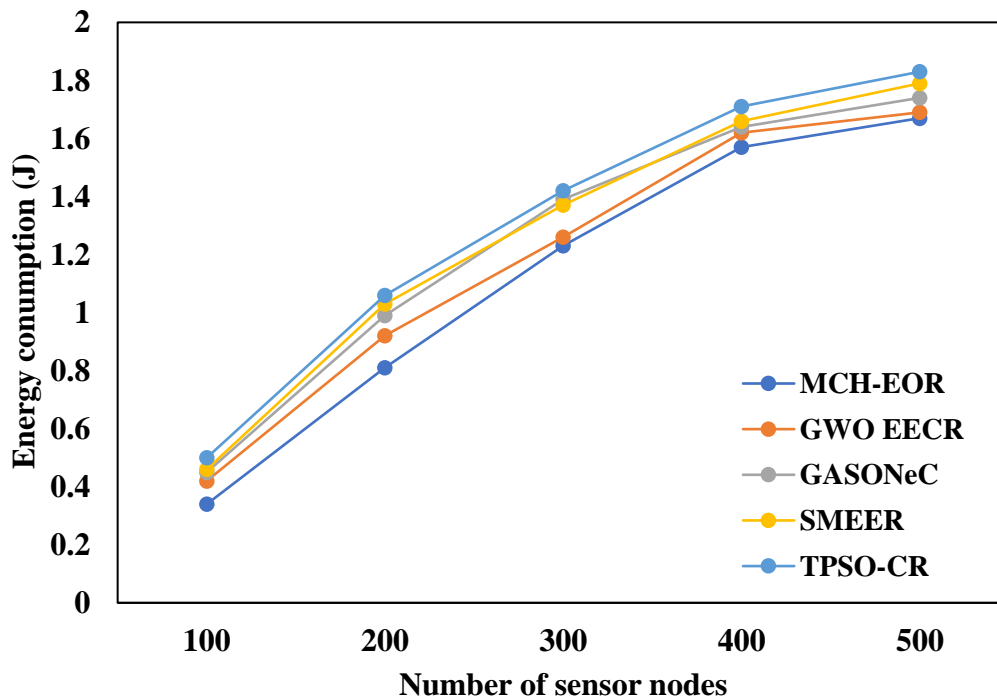

Fig. 5.9 Comparison of consumed energy

Table 5.5 Energy consumption

Number of Nodes -> (Approaches)	100	200	300	400	500
MCH-EOR	0.34	0.81	1.23	1.57	1.67
GWO EECR [200]	0.42	0.92	1.26	1.62	1.69
GASONEC [158]	0.45	0.99	1.39	1.64	1.74
SMEER [179]	0.46	1.03	1.37	1.66	1.79
TPSO-CR [181]	0.5	1.06	1.42	1.71	1.83

the energy used by cluster member. Figure 5.9 and Table 5.5 depicts the comparison of energy used by different approaches to process their intended tasks for varying number of SNs. As can be observed from Figure 5.9, the energy consumed by MCH-EOR for 100, 200, 300, 400 and 500 sensor nodes is 0.34, 0.81, 1.23, 1.57 and 1.67 respectively. The initial sensor energy is taken to be 2J for all the nodes. As compared with GWOEECR, GASONEC, SMEER and TPSO-CR the energy consumption is 0.2%, 0.32%, 0.35% and 0.47% less for 100 nodes respectively. For a maximum of 500 sensor nodes the energy consumption is 0.01%, 0.04%, 0.07% and 0.09% less respectively. It indicates the energy efficiency of the MCH-EOR protocol.

5.5.2.5 Throughput

This parameter defines the rate of data transferred to BS for diverse number of sensor nodes and is shown by Eq. (5.42).

$$\text{Throughput} = \frac{\text{No. of packets sent} * \text{packet size}}{\text{Time Taken}} \quad (5.42)$$

Figure 5.10 and Table 5.6 depicts the comparison of throughput of MCH-EOR with other compared schemes. The MCH-EOR shows a through put of 91% for 100 sensor node and 71% for 500 sensor nodes. In comparison GWO App., GASONEC, SMEER, and TPSO-CR shows a throughput of 90%, 88%, 86% and 85% for 100 sensor nodes while 69%, 68%, 63% and 61% for 500 sensor node deployment. For the other sensor nodes like 200, 300 and 400 the MCH-EOR performs nearly to GWO App. with a difference of 1%, 2% and 2% respectively. Overall the MCH-EOR has a better through put due to its clustering strategy based on multi-objective functions.

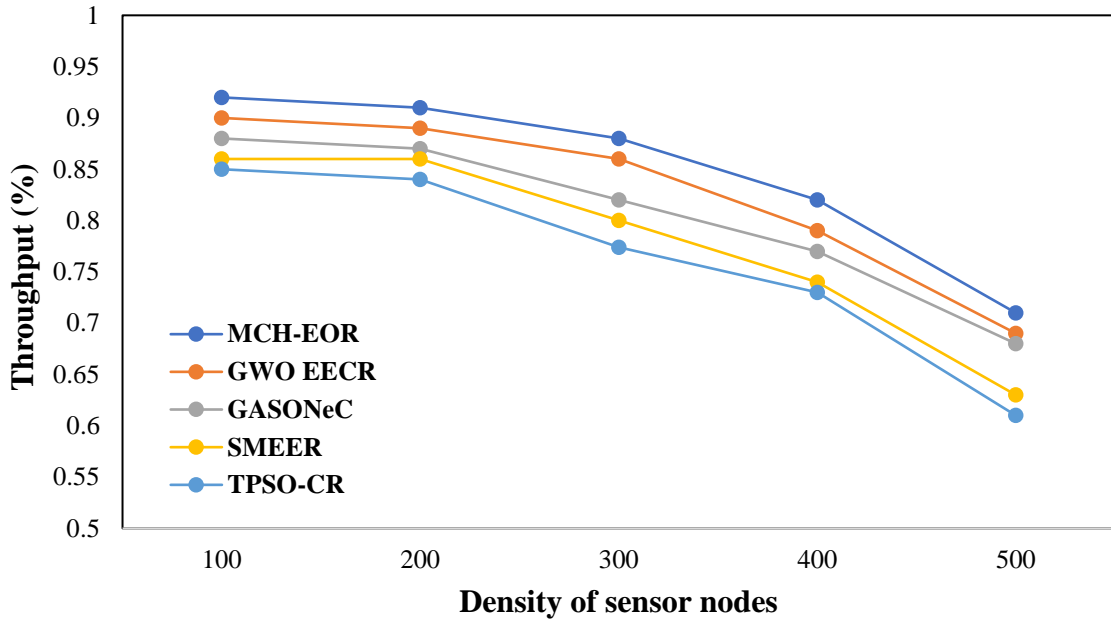

Fig. 5.10 Comparison of throughput

Table 5.6 Throughput (%)

Number of Nodes ->	100	200	300	400	500
(Approaches)					
MCH-EOR	0.91	0.9	0.88	0.81	0.71
GWOEECR [190]	0.9	0.89	0.86	0.79	0.69
GASONeC [158]	0.88	0.86	0.82	0.77	0.68
SMEER [179]	0.86	0.83	0.8	0.74	0.63
TPSO-CR [181]	0.85	0.82	0.77	0.71	0.61

5.5.2.6 Packet Delivery Ratio

Packet delivery ratio (PDR) defines the ratio of data packets delivered successfully to BS for various number of sensor nodes and is specified by Eq. (5.43).

$$\text{Packet delivery ratio} = \frac{\sum \text{No. of packets received}}{\sum \text{no. of packets sent}} \times 100\% \quad (5.43)$$

Comparison of PDR of proposed MCH-EOR with other compared optimization-based schemes shows that MCH-EOR fares better than compared approaches. Figure 5.11 depicts the packet delivery ratio of proposed as well as other compared schemes. It can be observed from figure that MCH-EOR successfully delivered 88.4% of packets for 500 SNs and 95.5% packets for 100 SNs. Other techniques have achieved delivery ratio of

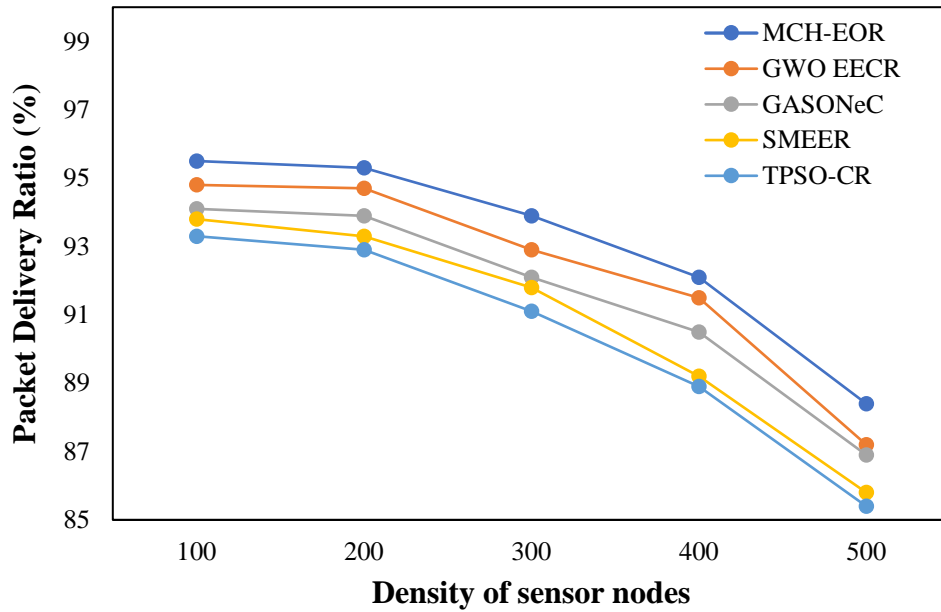

Fig. 5.11 Comparison of packet delivery ratio

Table 5.7 Packet Delivery Ratio (%)

Number of Nodes -> (Approaches)	100	200	300	400	500
MCH-EOR	95.5	95.1	92.2	92.1	88.4
GWO App. [200]	94.8	94.7	92.9	91.5	87.2
GASONeC [158]	94.1	93.9	92.1	90.5	86.9
SMEER [179]	93.8	93.3	91.8	89.2	85.8
TPSO-CR [181]	93.3	92.9	91.1	88.9	85.4

87.2%, 86.9 %, 85.8%, and 85.4 % for 500 SNs and 94.8%, 94.1%, 93.8% and 93.3% for 100 sensor nodes. The decrease in PDT is observed for each protocol due to increase in node density and increased multihopping.

5.5.2.7 Feature Comparison of MCH-EOR with existing approaches

The feature comparison of MCH-EOR with existing approaches in terms of energy-efficient route selection features in WSNs is given in Table 5.8. The cost function for proposed and other compared approaches is plotted and depicted in Figure 5.12. The figure shows that convergence speed of proposed MCH-EOR is better than GWO App., GASONeC, SMEER, and TPSO-CR selecting the energy-efficient optimized routing according to the fitness value function.

Table 5.8 Features Comparison of MCH-EOR with other compared approaches

Feature	GASONeC [158]	GWOEECR [190]	TPSO-CR [181]	SMEER [179]	MCH-EOR (Proposed)
Clustering	Yes	Yes	Yes	Yes	Yes
Routing	No	Yes	Yes	Yes	Yes
Evolutionary Approach	Yes	No	No	No	No
Swarm Intelligence	No	Yes	Yes	Yes	Yes
Inter-cluster communication	No	Yes	Yes	Yes	Yes
Multi-objective cluster head section	No	No	No	No	Yes
Optimized path selection	No	No	Yes	Yes	Yes
Path Alteration	No	No	No	No	Yes

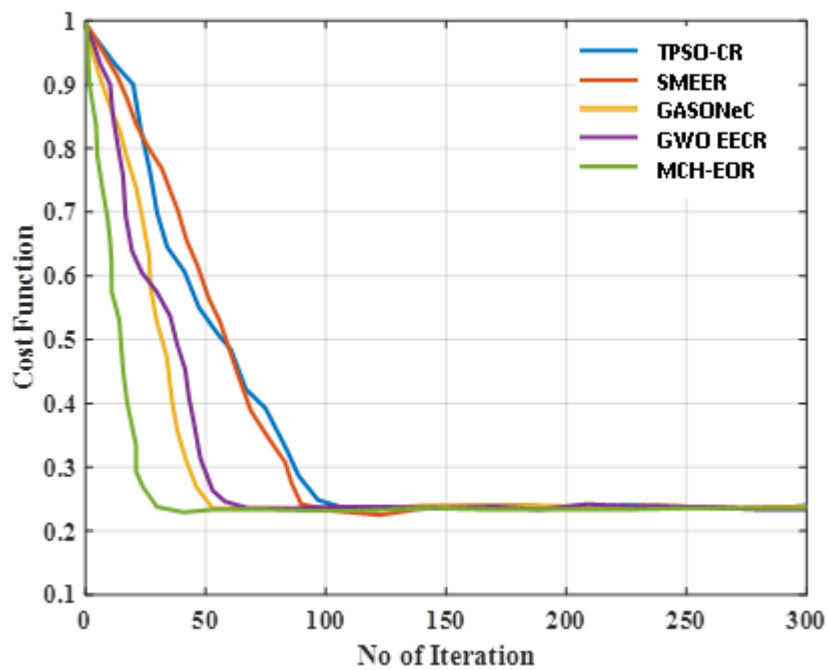

Fig. 5.12 Comparison of Cost Function Performance

5.6 Summary

The chapter described a new MCH-EOR protocol for energy efficient clustering and CH selection. It handles the problem of low life span of sensor nodes near to the BS also known as *network hole* problem. The MCH-EOR uses an energy-efficient cluster head selection

method based on multiple objectives like proximity, cost, residual energy, and coverage. SailFish optimization algorithm is used for optimal route selection from cluster head to the base station. It has been observed that MCH-EOR performed better than the compared protocols on various parameters such as energy consumption, packet delivery ratio and throughput and is shown in Figure 5.6 to Figure 5.11. The MCH-EOR survived for about 3485 rounds with 500 nodes and is better than the compared ones.

Chapter 6

LBNR-LEACH: An Enhanced Energy-Efficient Algorithm for Cluster Head Selection in WSN

LEACH and the protocols derived from it are energy efficient when transmitting data to the base station. These protocols follow a clustering approach with an overhead of optimal CH selection. These approaches have certain advantages and disadvantages for CH selection. For this purpose, several parameters have been considered, but these protocols lack in defining comprehensive criteria based on all the parameters for CH selection. Furthermore, the load on individual sensor nodes for CH selection is given little or no attention. Specifically, these protocols lack in finding any mechanism for a particular sensor's load identification. The proposed Load-Based-Node-Rank-Low-Energy-Adaptive-Clustering-Hierarchy (LBNR-LEACH) protocol presented in this chapter improves the Node Rank LEACH protocol that considers sensor node load along with the other parameters like residual energy, proximity, connected links, and distance. It considers both time and energy for finding the load on a CH. The simulation results are compared with LEACH, LEACH-I, and NR-LEACH on different parameters like throughput, packet delivery ratio, end-to-end delay, and live nodes.

6.1 LBNR-LEACH Description

The LBNR-LEACH algorithm is an improvement to the Node-Rank-LEACH (NR-LEACH) [145] algorithm. It considers network load as an additional parameter along with residual energy, distance, and count of links on sensor nodes. The process first computes the node rank according to the strategy specified in the NR-LEACH algorithm and waits for some static duration to find the network load. The network load is computed by comparing the amount of energy consumed and transmitter range by each candidate CH in

The contents are published in ¹ Mehta, D, Saxena, S. Load-based node ranked low-energy adaptive clustering hierarchy: An enhanced energy-efficient algorithm for cluster head selection in wireless sensor networks. *Concurrency Computat Pract Exper.* 2021; 33:e6416. <https://doi.org/10.1002/cpe.6416>

the region. NR-LEACH is derived from LEACH-I [146], and LEACH-I is derived from LEACH. A brief description of these protocols is given in section 6.1.1.

6.1.1 Background: Node-Rank LEACH Algorithm

The Node Ranked LEACH protocol tries to distribute energy load on sensor nodes optimized by using its Node Ranked Algorithm shown in Algorithm 6.1 for selection of cluster head [155]. It is an updated variant of the Low-Energy-Adaptive-Clustering-Hierarchy (LEACH) protocol. LEACH uses the clustering concept to organize sensor nodes, as adaptively shown in Figure 6.1. Here the CHs are rotated in random order to limit the load on a single cluster head. The CH performs the duty of data aggregation and remote communication.

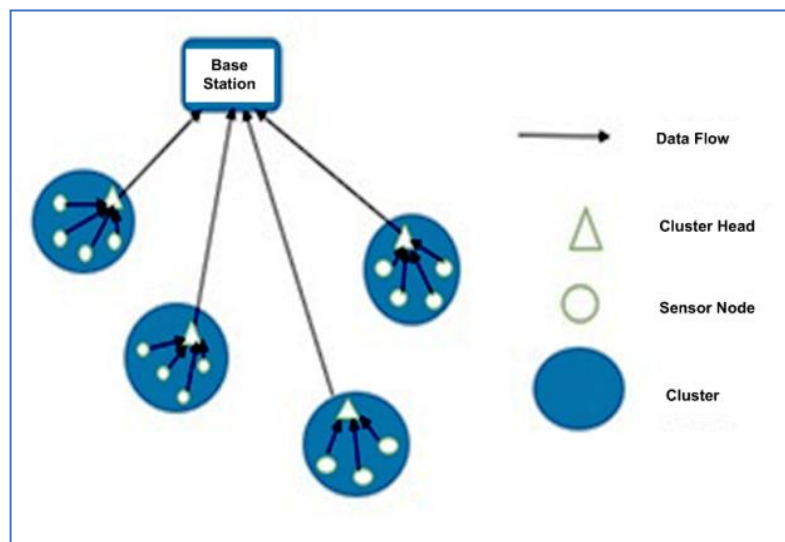

Fig. 6.1 Cluster Formation using LEACH protocol

The sensor node chooses an arbitrary value between 0 and 1. If this random value is lesser than a given threshold as given in Eq. (6.1), this sensor node will be CH for the present pass.

$$T(n) = \begin{cases} \frac{P}{1 - P * (r \bmod (1/P))} , & \text{if } n \in G \\ 0 & \text{otherwise} \end{cases} \quad (6.1)$$

Here, P is the requisite proportion of CH sensor nodes, r is the present iteration number, and G represents a collection of sensor nodes which have not become CH in previous $1/P$ rounds. It implies that in the next $1/P$ rounds, every node shall have an opportunity to be a CH. This rotation for the role of CH helps in energy conservation. All the elected Cluster Heads broadcast their announcement advertising themselves as CH to non-CH nodes using

CSMA-MAC. By the end of this phase, every sensor node that is not a CH joins a cluster depending on its proximity to the CH node, calculated by received signal strength. An improvement to basic LEACH is improved LEACH (LEACH-I). It reflects on the use of residual energy and distance as two factors in the selection of CH. Both parameters are used to calculate the decision variable (d_{ij}) value using Eq. (6.2).

$$d_{ij} = \alpha (s_{ij})^2 + \beta (E_i - E_m)^2 \quad \text{where } \alpha = \Delta E_{avg}, \quad \beta = \Delta S_{avg} \quad (6.2)$$

Here, E_i is the initial energy of each node, E_m is the CH remaining energy, s_{ij} is the distance between node i and CH j , α represents the mean value of first order differences of used energy by the sensor nodes and β represents the mean value of first order differences of distance among sensor nodes.

Algorithm 6.1 Node Ranked LEACH algorithm

Input: list of sensor nodes (N); **Output:** list of sorted nodes

1. **Begin**
 2. flag= false;
 3. **For** $i \in N$ // each sensor i in N
 4. NR(n_i) = 1; //set Node Rank (NR) for each node to 1
 5. prev_output_list <- NR(n_i);
 6. **End For**
 7. **While** (flag = true)
 8. **For** $j \in N$
 9. get NR(n_j);
 10. get PO(n_j); // PO(n_j) is the current energy of node n_j
 11. get distance between n_j and n_i into dt_{out}^{ij} ;
 12. **For** $k \in N$
 13. dt_{out}^{ik} = get distance between the n_k and n_j ;
 14. **End For**
 15. NR(n_j) = PO (n_j) * α * NR (n_i) $\frac{1}{d_{out}^{ij}}$ + (1- α);
 16. store NR(n_j) into output_list;
 17. **End While**
 18. **if** (prev_output_list == output_list)
 19. flag = true;
 20. **else**
 21. prev_output_list = output_list;
 22. **end if**
 23. **End While**
 24. sort output_list;
 25. **End**
-

The Node-Rank LEACH algorithm overcomes the scalability issue of the LEACH protocol. Here, the CH managing high number of sensor nodes shall be receiving data from more number of nodes, consuming more energy and thus shall have a shorter lifespan leading to the need of selecting a new cluster head which again would be an overhead affecting overall network lifetime. The protocol is separated into two stages called setup phase and steady phases respectively. During the setup phase, cluster establishment and selection of CH takes place. CH is selected by using the node rank algorithm, which uses three parameters; residual energy, position, and a number of link connections with other sensor nodes. The rank of a node ($R(n_i)$) is computed by Eq. (6.3):

$$R(n_i) = EO(n_{ij}) * \alpha * \sum_0^i R(n_i) \frac{1/d_o^{ij}}{\sum_{k \in SN} d_o^{ik}} + (1-\alpha) \quad (6.3)$$

Here, d_o^{ij} represents distance of an outgoing link's edge from node j to node I , SN is a set of neighbours of k , $EO(n_{ij})$ represents the present energy level of i^{th} node, α is damping factor having value 0.85 as taken from EI-Fishawy in Arabic summarization in Twitter. The rank of a node is related to the importance of nodes linked with a node. At the start of the algorithm, each node is given an initial rank of '1'. Then, the calculation as in Eq. (6.3) is repeated as per the iterative algorithm until it gets the convergence score. In each round, a closer value of final weight is attained.

6.1.2 LBNR-LEACH Protocol Assumptions

Following are some of the assumptions for the proposed algorithm:

1. Sensor nodes are deployed arbitrarily and uniformly across a specified area.
2. All the sensor nodes are motionless after they have been deployed.
3. Nodes are homogeneous with the same initial energy, communication, and processing capabilities.
4. Nodes communicate with each other and have data to send.
5. Sensor nodes are unaware of their location.
6. The estimation of the distance between sensor nodes is based on the strength of received signals.
7. The nodes are said to be dead when total energy has been depleted.

6.1.3 Radio Model for LBNR-LEACH

The radio energy degeneracy model as given in [7] has been used for the proposed protocol. According to the model, a transmitter spends energy on radio power amplifier and electronics while the receiver spends energy on radio electronics, as represented by Figure 6.2. Free space and multipath fading channel are being used based on the distance between source and destination. If the distance (d) between receiver and sender is smaller than a threshold distance, then the free space model is to be applied, and if this distance is more than the threshold distance, a multipath fading channel is used. In the free space model, energy dissipation is square of the distance, i.e., d^2 , whereas in the case of multipath fading channel, energy dissipation goes much higher to d^4 .

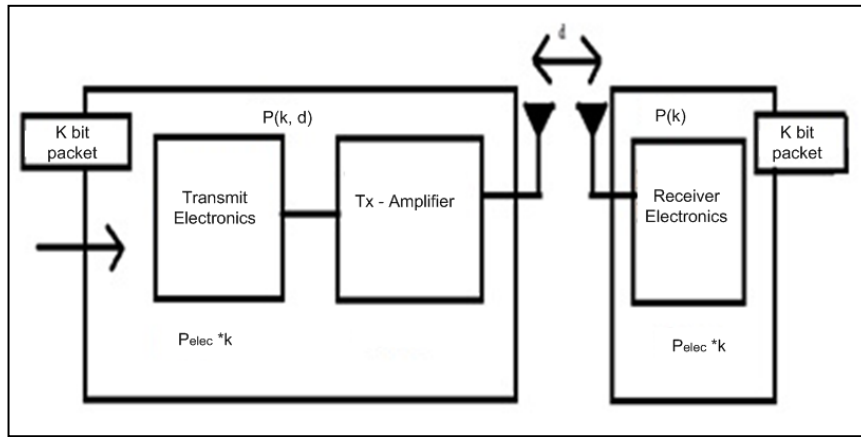

Fig. 6.2 Radio Model

Thus, the energy consumption of a sensor node during transmission of a packet of k bits to another sensor node at distance d is given by Eq. (6.4).

$$P_s = \begin{cases} k * (P_{elec} + P_{fs} * d^2); & d < d_0 \\ k * (P_{elec} + P_{mp} * d^4); & d \geq d_0 \end{cases} \quad (6.4)$$

Here, P_{elec} represents requisite energy to stimulate the electronic circuit of sensor node and is influenced by a number of issues like signal modulation, digital coding, spreading and filtering of signal. The amplifier energy $P_{fs} * d^2$ or $P_{mp} * d^4$ is determined by the distance between sender and receiver with tolerable bit error rate. P_{fs} represents requisite energy for sending a bit into free space and P_{mp} shows energy for sending a bit through multipath fading channel with d being distance between sender and receiver while d_0 is threshold distance. The energy consumed to receive a packet of k bits is represented by Eq. (6.5) [31].

Whereas energy consumed in data aggregation at cluster head node is calculated with Eq. (6.7).

$$d_0 = \sqrt{P_{fx}/P_{Mp}} \quad (6.5)$$

$$P_R = k * P_{elec} \quad (6.6)$$

$$P_{agg} = P_{DA} * k * n \quad (6.7)$$

Here k gives the count of bits in a packet and n is the count of messages whereas P_{DA} is requisite energy to aggregate one bit.

6.2 LBNR-LEACH Algorithm

The LBNR-LEACH algorithm has been designed to work in two phases: the setup and steady-state phases. The setup phase is the initialization of the network along with selected CH, and in the steady-state phase the network is ready for data communication. The two states are described in sections below.

6.2.1 Setup phase

The setup phase is the stage in which the selection of cluster head is done. The CH is selected according to node rank Algorithm 6.1, and the network load is taken as an additional parameter for CH selection [155]. The rank of a given sensors node i is calculated by Eq. (6.3). The importance of a node depends upon its linkage with other significant nodes. At the start of the algorithm, a node rank, one, is assigned to each node. The algorithm iterates as per Eq. (6.3) to reach a convergence score. Every iteration leads to a closing value of the final weight. Figure 6.3 demonstrates the significance of link connections' importance aspect with ranks of nodes in a network represented in percentage. Node B has a higher rank than node E or H despite having fewer links. It is because node C is attached to B that has more number of nodes linked with it. The calculation of node rank needs a number of iterations through the collection because of the damping factor. The iterations are carried out to adjust rough values of node rank to make the node rank more precise and closer to the theoretical value. The algorithm keeps a record of the calculated

node rank and recalculates the node rank several times until the values for node rank become stable. Once the node ranks become stable, the LBNR-LEACH protocol waits for a specific time to calculate the network load on the cluster. The algorithm is shown in Algorithm 6.2 and Figure 6.4. Identifying network load on a cluster is challenging, and the concept of power relativity is used to overcome this challenge.

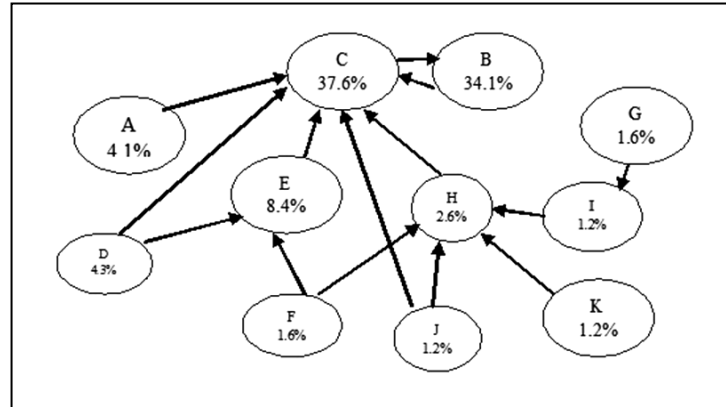

Fig. 6.3 Link Importance

The node with a lesser load shall have consumed less energy compared to the node with a higher load in it. The traffic identification is made by waiting for few seconds and checking the power difference at each node. It depicts the amount of load. On this basis, a priority to the node is assigned and hence more importance is given to that cluster head. As an illustration, if at time t , the energy levels of some nodes N_1 , N_2 , and N_3 are 100 percent. This shows that N_3 is utilized most, and hence the data traffic is high on this node. As a solution to this problem, the LBNR-LEACH takes power and time to calculate the load on the specific CH node. The elected CH sends a message as an advertisement through CSMA-MAC protocol to the other SNs. The SN sends an acknowledgment showing their interest to join the cluster as a member. The initial energy consumption of nodes in a cluster is given by Eq. (6.8). Here, $P(N)$ is the power of the n^{th} node.

$$\sum_{i=1}^a P(N_i) + \sum_{i=1}^b P(N_i) + \sum_{i=1}^c P(N_i) + \dots + \sum_{i=1}^z P(N_i) = \sum_{i=1}^n P(N_i) \quad (6.8)$$

After running the algorithm the energy of cluster is iterated through Eq. (6.9).

$$\sum_{i=1}^a P(N_i) + \sum_{i=1}^b P(N_i) + \sum_{i=1}^c P(N_i) + \dots + \sum_{i=1}^z P(N_i) < \sum_{i=1}^n P(N_i) \quad (6.9)$$

From the Eq. (6.8) and Eq. (6.9) we can interpret the Eq. (6.10) as

$$\sum_{i=1}^a P(N_i) + \sum_{i=1}^b P(N_i) + \sum_{i=1}^c P(N_i) + \dots + \sum_{i=1}^z P(N_i) \leq \sum_{i=1}^n P(N_i) \quad (6.10)$$

Second, if $N_{ix} \neq N_{iy}$, then either $N_{1x}+N_{2x}+N_{3x}.....N_{nx} < N_{1y}+N_{2y}+N_{3y}.....N_{iy}$ with power consumption given by Eq. (6.12) or $N_{1x}+N_{2x}+N_{3x}.....N_{nx} > N_{1y}+N_{2y}+N_{3y}.....N_{iy}$ with power consumption given by Eq. (6.13).

$$\sum_{i=1}^x P(N_i) < \sum_{i=1}^y P(N_i) \quad (6.12)$$

$$\sum_{i=1}^x P(N_i) > \sum_{i=1}^y P(N_i) \quad (6.13)$$

The fitness function (*FF*) for LBNR-LEACH is given by Eq. (6.14)

$$FF = \text{Sort}(R(n_i)) \quad (6.14)$$

Where, $R(n_i)$ is the rank calculated by Eq. (6.3) and the objective function (*OF*) in Eq. (6.15) may be achieved.

$$OF = \text{Max}(\sum_{i=1}^n P(N_i)) \quad (6.15)$$

The steps for sensor node rank calculation and load identification is shown in Algorithm 6.2. Here in this process, initially, each sensor is assigned a *rank=1* shown in step 3. The initialized rank is stored in an array name *prev_output_list*. This array is used for further computation. In the next step of iteration in step 7, the node ranking is done by considering the parameters like distance, residual energy, and the number of links. The computed rank is stored in another array named *output_list*. The two output lists are compared as shown in step 17 to update the node ranks. After completion of each round, the same process is computed to find the new ranks. Further, in addition to node rank, the sensor load is also calculated as stated in step 24. There is a wait time of the 60s to have nodes settle down to steady-state and compute load. Another data structure called *list_after* is used to store the results. Finally generated network load list is computed in *list_final* that actually indicate the list of nominated CHs. Finally, the fitness function shown in Eq. (6.14) and objective function in Eq. (6.15) is computed.

Algorithm 6.2 LBNR-LEACH algorithm

Input: list of sensor nodes (N); **Output:** list of sorted nodes

```
1. Begin
2. flag= false;
3. For  $i \in N$  // each sensor  $i$  in  $N$ 
4.    $NR(n_i) = 1$ ; //set Node Rank (NR) for each node to 1
5.   prev_output_list <-  $NR(n_i)$ ;
6. End For
7. While (flag = false)
8.   For  $j \in N$ 
9.     get  $NR(n_j)$ ; //compute node rank
10.    get  $PO(n_j)$ ; //  $PO(n_j)$  is the current energy of node  $n_j$ 
11.    get distance between  $n_j$  and  $n_i$  into  $dt_{out}^{ij}$ ;
12.    For  $k \in N$ 
13.       $dt_{out}^{lk}$  = get distance between the  $n_k$  and  $n_j$ ;
14.    End For
15.     $NR(n_j) = PO(n_j) * \alpha * NR(n_i) \frac{1}{dt_{out}^{ij}} + (1-\alpha)$ ;
16.    store  $NR(n_j)$  into output_list;
17.  End For
18.  if (prev_output_list == output_list)
19.    flag = true;
20.  else
21.    prev_output_list = output_list;
22.  end if
23. End While
24. // Calculation of the Load on Sensor Node after some time interval
25. For  $i \in N$  // each sensor  $i$  in  $N$ 
26.   record  $P(i)$  in list_before; //where  $P(i)$  is power of  $i$  node
27.   wait(60s);
28.   For  $j \in$  output_list
29.     record  $P(j)$  in list_after;
30.   End For
31. End For
32. For  $i \in N$  // each sensor  $i$  in  $N$ 
33.   list_final = list_after( $n_i$ ) - list_before( $n_i$ );
34. End For
35. sort list_final;
36.  $OF = \text{Max}(\sum_{i=1}^n P(N_i))$ ;
37.  $FF = \text{Sort}(R(n_i))$ 
38. End
```

6.2.2 Steady State Phase

The steady phase begins once clusters have been finalized and CHs are selected. In this state, the actual data communication takes place. The cluster head decides and disseminates Time Division Multiple Access (TDMA) for communication among the nodes. The

mechanism works like a sleep/awake schedule in which the nodes which are not going to send/receive data as per the TDMA schedule can go into a sleep state and conserve energy. According to the allocated timeslot assigned to various sensor nodes, data communication during this steady-state phase is carried out. After gathering requisite data, the CH applies aggregation on the collected information. It uses an aggregation function on accumulated knowledge so that the amount of information to be transmitted may be reduced and conserve energy. Once the data aggregation is completed, the aggregated facts are sent to BS for useful processing. After completing the steady phase, the algorithm proceeds to another cycle of setup phase for cluster setup and cluster head selection. That again followed up by a steady stage, and the iterative process carries on. Thus, the proposed algorithm enhances network lifespan by prolonging the lifetime of sensor nodes because it does not randomly select cluster heads. It works on the rank of the nodes, considers the power of nodes and time for the selection of CH.

6.3 LBNR LEACH Performance Evaluations

The performance of LBNR LEACH is evaluated on simulations and is compared with LEACH, LEACH-I, and NR-LEACH. The parameters considered for the study are energy proportion, packet delivery ratio, load at the cluster, end-to-end delay, throughput, and number of alive nodes. The Network Simulator (NS2) on the Ubuntu, 32 bits operating system [25] is used. The simulation parameters are shown in Table 6.1. The simulation results show that LBNR LEACH performs well compared to NR-LEACH on specified parameters.

Table 6.1: Network Simulations parameters

Simulations Parameters	Parameter Value
Quantity of Nodes	10-400
NS Version	NS-2.35
Duration of Simulation	1000 ms
Interface Queue	DropTail
Size of Packet in bytes	512
Network Interface	Wireless
Data Rate	10 bps

6.3.1 Throughput

It is the amount for packets/data passes through the system per unit time and is typically measured in Kilobits per seconds. It is computed using Eq. (6.16)

$$\text{Throughput (Th)} = \frac{\text{Received Packets Count} * \text{Packet Size}}{\text{Time Period of Transmittal}} = \frac{RP * P_{Size}}{\text{Time}} \quad (6.16)$$

LBNR-LEACH is compared with LEACH, LEACH-I and NR-LEACH protocols and the results are shown in Figure 6.5 and Table 6.2. The proposed protocol works well under normal network scenario and is capable of dealing network load during peak time. It shows a throughput of 8.5 for a small network of 10 nodes and 48.94 for a network of 400 nodes. It shows approximately 7%, 19.8% and 46.8% better performance when compared to NR-LEACH, LEACH-I and LEACH protocol for 10 sensor nodes. While for a dense deployment of 400 sensor nodes it shows 4%, 30.69% and 91.1% better performance. The performance difference of proposed algorithm to LEACH is far better and is because of strategy of CH selection in LBNR-LEACH algorithm. LEACH does not allow multi objective function to find the efficient CH while LBNR LEACH uses various parameters to find the best CH.

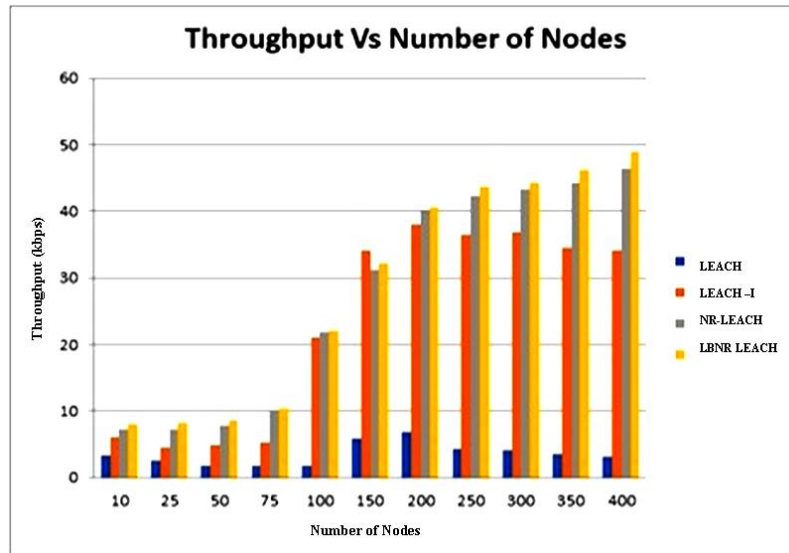

Fig. 6.5 Throughput Vs Count of nodes

Table 6.2 Throughput

Number of nodes ->	10	25	50	75	100	150	200	250	300	350	400
LBNR-LEACH	8.50	8.61	9.12	10.01	21.92	32.02	40.01	43.32	44.20	46.81	48.94
NR-LEACH [145]	7.90	8.01	8.51	10.01	20.53	30.09	39.99	41.95	43.22	44.15	46.95
LEACH-I [146]	6.81	4.93	4.92	5.22	20.01	33.91	38.54	37.92	38.22	34.23	33.92
LEACH [131]	4.52	2.95	2.01	2.13	2.36	6.95	7.73	4.12	3.92	3.87	3.74

6.3.2 Mean End-to-End Delay

It means delay of time of packets moving in between senders and receiver. It is computed by Eq. (6.17) in milliseconds. In LEACH protocol, nodes are always active, and there is a delay in packets movement from sender to receiver. In comparison to other protocols, LBNR-LEACH fares better with lower delay in packet delivery, as shown in Figure 6.6 and Table 6.3.

$$(Avg_{Delay}) = \sum_{i=0}^N \frac{Receiving\ Time - Sending\ Time}{Received\ Packets\ Count} = \sum_{i=0}^N \frac{T_{Recd} - T_{Sent}}{RP} \quad (6.17)$$

LEACH as being the fundamental protocol shows a high end-to-end delay in comparison to others. This is due to the static clustering approach of it. The NR-LEACH and LBNR-LEACH performs a significant job to eliminate end-to-end delay. This is due to node ranking and efficient CH selection. LBNR-LEACH shows an end-to-end delay of 0.01 for 10 sensor nodes and 8.86 for a big network of 400 nodes. This is attained due to load estimation in each round of observation for each eligible CH.

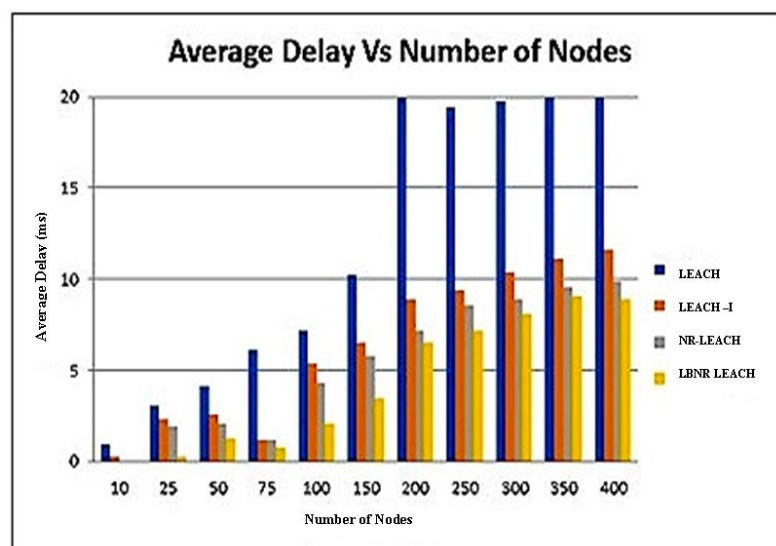

Fig. 6.6 Average Delay vs Number of Nodes

Table 6.3 Average Delay

Number of nodes -> (Approaches)	10	25	50	75	100	150	200	250	300	350	400
LBNR-LEACH	0.01	0.05	1.61	0.99	2.35	3.82	6.89	7.42	7.63	8.88	8.86
NR-LEACH [145]	0.03	2.43	2.45	1.58	4.91	6.09	7.41	7.85	8.22	9.91	9.99
LEACH-I [146]	0.05	2.49	2.52	1.58	5.05	6.65	8.89	8.85	10.05	11.03	12.02
LEACH [131]	1.19	2.93	4.01	6.19	7.36	10.05	19.99	19.81	19.91	19.99	19.99

6.3.3 Packet Transfer Ratio

It is defined as the percentage of packets effectively received by the base station to the total count of information packets sent. It can be numerically given by Packet Delivery Fraction (PDF) by Eq (6.18). According to simulation results, the proposed algorithm works better in PDF and successfully delivers more packets from the sender to the receiver, as shown in Figure 6.7 and Table 6.4.

$$PDF = \frac{\text{Received Packets Count}}{\text{Sent Packets Count}} * 100 = \frac{RP}{SP} * 100 \tag{6.18}$$

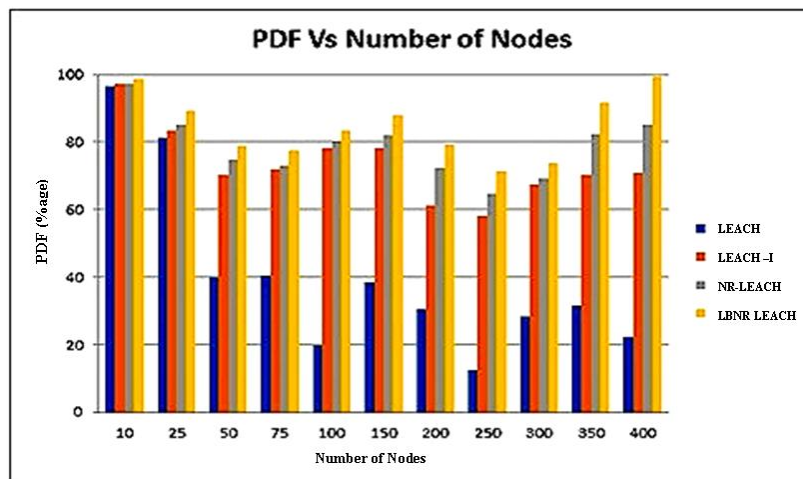

Fig. 6.7 PDF vs Number of Nodes

Table 6.4 Packet Transfer Ratio

Number of nodes -> (Approaches)	10	25	50	75	100	150	200	250	300	350	400
LBNR-LEACH	98.09	89.99	79.81	77.85	82.9	87.88	79.01	72.89	73.01	92.12	99.25
NR-LEACH [145]	95.23	84.91	78.98	73.01	80.1	81.91	72.12	66.52	68.91	81.82	83.8
LEACH-I [146]	93.04	82.12	71.84	71.9	78.40	78.90	61.88	59.01	67.25	70.04	72.01
LEACH [131]	91.12	81.01	40.5	40.09	20.05	39.09	29.35	14.01	28.9	31.02	32.01

From the Table 6.4 the packet transfer ratio of LBNR-LEACH variable from 98.09 to 72.89 for 10 nodes and 250 nodes. The variation in the performance of LBNR-LEACH is due to increase in the density of the network from 10 nodes to 400 nodes. Due to increase in the density the candidate CH increases along with the multihopping. Due to the availability of more number of candidates CH the load estimation can be easily done and the network performance increases gradually once again.

6.3.4 Average Energy Ratio (AER)

It is the mean energy used up by individual node divided by the overall energy available at the node. It can be mathematically given by Eq. (6.19).

$$AER_{Avg} = \frac{\text{Consumed Energy}}{\text{Available Energy}} = \frac{Energy_C}{Energy_A} \quad (6.19)$$

The LBNR-LEACH algorithm lowers the average energy intake by sensor nodes because the algorithm considers network load, distance, residual energy, and the number of links for selecting CH. Hence it leads to a more efficient CH election and gives better AER, as shown in Figure 6.8 and Table 6.5. Table 6.5 indicate that LBNR-LEACH has an average energy ratio of 29.8, 74.9, 81.09, 90.05 and 92.23 for sensor nodes 10, 75, 200, 300 and 400 respectively. If it is compared with NR-LEACH, LEACH-I and LEACH a significant energy gain is observed.

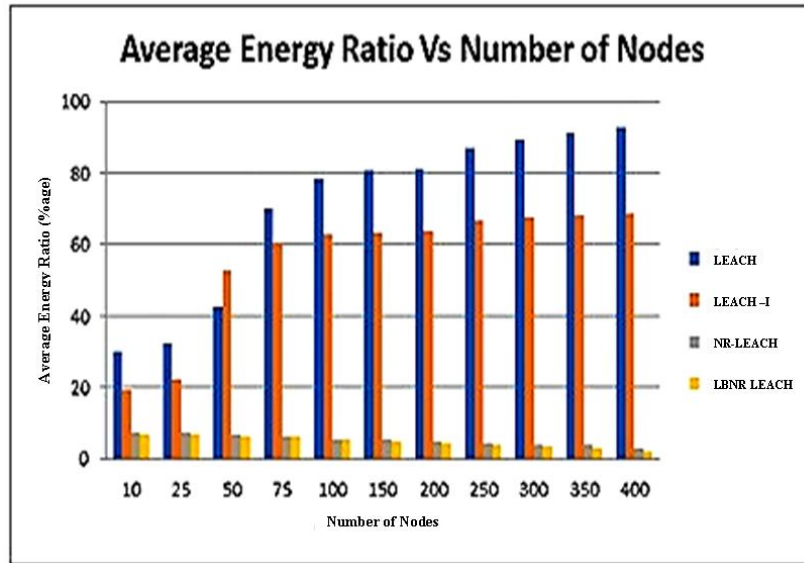

Fig. 6.8 Average Energy Ratio

Table 6.5 Average Energy

Number of nodes -> (Approache)	10	25	50	75	100	150	200	250	300	350	400
LBNR-LEACH	29.8	31.2	53.2	74.9	79.22	80.05	81.05	87.89	90.05	90.05	92.23
NR-LEACH [145]	19.92	21.3	41.9	60.02	62.01	62.04	62.05	64.03	66.05	66.01	66.89
LEACH-I [146]	7.4	7.32	6.51	99.07	6.51	6.24	6.12	6.05	5.99	5.75	5.23
LEACH [131]	6.98	6.88	6.42	6.92	6.85	6.35	6.04	5.88	5.45	5.05	4.89

6.3.5 Number of Alive Nodes

The node's lifetime in LBNR is high because the algorithm considers links with other nodes, leftover energy, distance from the sink, and load at proper nodes. Therefore, the overhead of cluster head selection is comparatively reduced. From Figure 6.9 and Table 6.6, it is evident that the LBNR protocol has a higher count of alive nodes in comparison to LEACH and its variants. From Table 6.6 it can be seen that the LBNR-LEACH has 359 nodes alive even for a big network setup of 400 nodes, comparatively NR-LEACH, LEACH-I and LEACH has 353, 347 and 264 respectively. For a smaller network of 25 or 50 nodes the alive node in case of LBNR-LEACH are 24 and 49 respectively while in that case of NR-LEACH, LEACH-I and LEACH it is (23, 46), (22, 41) and (14, 29) respectively.

Table 6.6 Alive Nodes

Number of nodes -> (Approaches)	10	25	50	75	100	150	200	250	300	350	400
LBNR-LEACH	9	24	49	70	89	128	162	230	264	308	359
NR-LEACH [145]	8	23	46	68	86	123	159	225	258	306	353
LEACH-I [146]	6	22	41	59	82	120	154	221	246	298	347
LEACH [131]	2	14	29	50	69	99	115	122	169	225	264

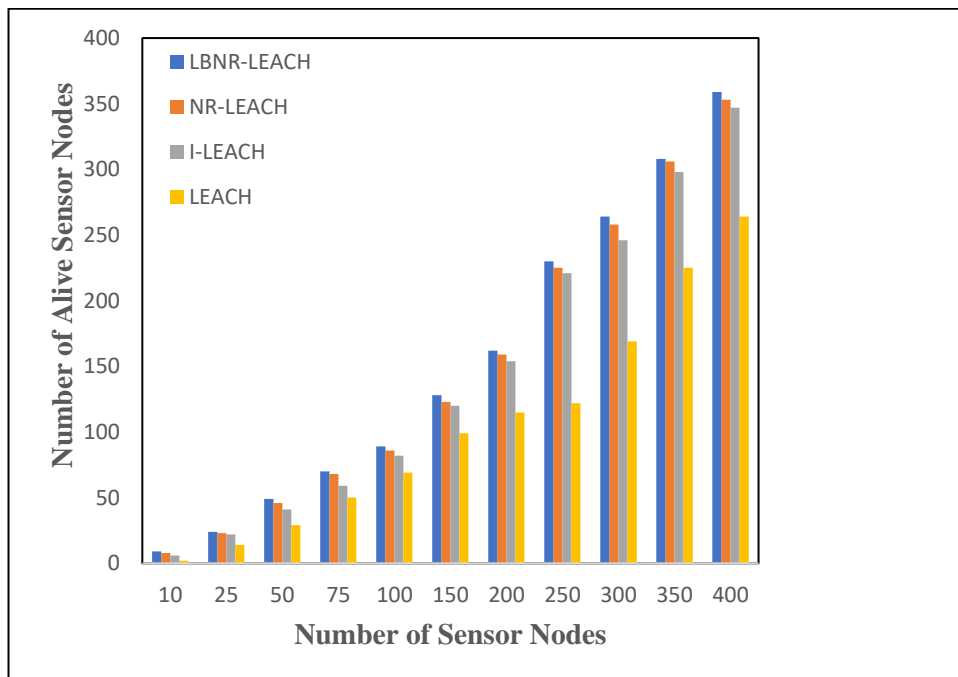

Fig. 6.9 Number of Alive Nodes

6.4 Summary

The clustering approach like LEACH is a more effective way to manage sensor nodes and energy-efficient data communication. The challenge of CH selection in LEACH has been discussed in different researches by researchers. The node rank algorithms work well for CH selection by ranking the nodes in the setup phase, but network load during the running phase has given no attention to these protocols. The proposed LBNR-LEACH protocol is intended to consider the remaining energy of nodes, distance, number of links, and network

load at the running phase on nodes for selecting a CH. The LBNR approach considers an additional parameter of network load in the cluster and introduces the concept of waiting time to compute it. This approach hinders the random process of CH selection that causes untimely failure of CH nodes in LEACH and some of its variants. The simulation results from Figure 6.5 to Figure 6.9 depict that the proposed algorithm performs better than LEACH, LEACH-I, and NR-LEACH in terms of network and energy consumption lifetime.

Conclusion and Future Scope

7.1 Conclusion

With the advancement in technology and easy availability of reliable, cost-effective sensors, WSN is finding its scope in diverse fields, including environment monitoring, battlefield monitoring, remote observations of vital health parameters of a patient, tracking of wild animals in inaccessible forests, structural health monitoring of buildings and so on. With the surge of IoT, the role of WSNs is becoming increasingly important in the applications affecting modern-day life daily, leading to a paramount need to address various challenges for WSNs. The sensor nodes that constitute a WSN are energy and resource-constrained devices armed with limited energy, processing, and storage capabilities. Sustaining the energy of sensor nodes for long durations is perhaps the biggest challenge in the construction of a WSN. Generally, these sensor nodes are deployed in physically harsh surroundings where it might not be possible to replace or replenish their batteries. Once the total energy is consumed, the sensor node is supposed to be dead as it cannot perform its intended tasks. In this situation, sensor nodes who were communicating earlier with that sensor node cannot continue communication further and hence causes problems of network holes. Many energy-saving mechanisms had been proposed to save the energy of wireless sensor nodes. It includes optimizing radio antenna, reducing the amount of data to be communicated, sleep/wake mechanism for sensors, energy harvesting, and energy-efficient routing. The big reason for energy depletion is data transmission and reception.

Moreover, with the increase in distance between source and destination, the amount of energy consumption also increases. Therefore, energy-efficient routing becomes necessary to route among sensor nodes to save energy. Many categories of routing protocols such as Network flow, Data-centric, Geographical location-based, QoS-based and Hierarchical have been studied in the literature. The hierarchical approach of routing has been preferred due to its high capability to reduce the energy consumption of WSN as compared with others. In these protocols, sensor nodes form clusters depending on various criteria like residual energy, distance, etc. After the cluster formation, a CH is selected for each cluster. All the sensor nodes send their sensed values to elected CH, who aggregates it and transmits

it to the base station. This hierarchical approach is extended using inter-cluster head communication wherein CHs send data to another nearby CH instead of directly sending it to BS. The hierarchical routing approach is beneficial for two reasons. First, SNs communicate to shorter distances while transmitting the sensed values to the cluster head. Second, instead of all the SNs transmitting the data directly to BS, only one SN, i.e., the CH, sends the aggregated value to the BS. Hence, the hierarchical routing approach reduces the distance to communicate, the amount of data to be sent, and the number of nodes directly transmitting to BS. Here the cluster head selection is an overhead that is incurred by sensor nodes. The cluster heads may die sooner as they have to spend more energy collecting, aggregating, and transferring data to the other cluster heads or BS. Thus, there is a need to select an optimum CH to sustain for a longer duration. Also, WSNs may suffer from an energy hole problem, which arises because energy depletion is comparatively higher for sensor nodes closer to BS as they are receiving more data from other CH node sensor nodes comparatively away from BS. Keeping these research problems into consideration, three hierarchical protocols have been devised, namely FMCB-ER, MCH-EOR and LBNR-LEACH.

FMCB-ER allows CH selection in three steps: cluster creation, CH selection, and route discovery from SNs to BS. Cluster creation is performed through the grid method. After grid formation, TOPSIS (Technique for Order of Preference by Similarity to Ideal Solution) and AHP (Analytic Hierarchy Process) methods are used in combination to find CH. For optimal CH selection, the three essential parameters: neighbourhood, distance, and connectivity are considered. After CH selection EPO is used to find the optimal path for data transmission. The simulation results of FMCB-ER are compared with LEACH, RFCM-ACO, COARP and TCBR on the parameters energy efficiency, throughput, latency, jitter, end to end delay, packet delivery ratio, number of dead and alive nodes. The comparison shows that FMCB-ER is an improvement to the existing approaches in terms of energy efficiency. FMCB-ER can complete more than 2300 and 1500 rounds with 122 and 273 nodes, respectively. It reduces the energy consumption by about 0.4mJ in comparison to LEACH. It has a throughput of 96% for 100 nodes and 88% for 300 nodes. The end-to-end delay is observed to be 2.88 for 100 nodes and 8.8s for 300 nodes. The latency computed for FMCB-ER is 26.3s and is lesser than the compared approaches. The network enhancement of 4.38% is found with a network setup of 300 nodes and is an improvement of the other approaches. Moreover, FMCB-ER is found to have a smaller

number of dead nodes and a more significant number of alive nodes compared to other approaches.

The MCH-EOR is another approach for CH selection and energy-efficient routing in WSN. It resolves the problem of over trafficking near the sink station. It expedites in four steps: setting network, energy model design, clustering, and identification of route. The sensor network topology is designed with one BS and randomly distributed sensor nodes during the network setting. Finally, the free space energy model is used to make an investigation on energy consumption. The CHs are created using multi-objective parameters and objective functions. The route is identified with the help of SailFish optimization algorithm. The MCH-EOR is compared to the other existing approaches like GWO App., GASONEC, SMEER, and TPSO-CR of routing that are based on GWO, GA, ALO and PSO on parameters energy consumption, jitter, network lifetime, packet delivery ratio, throughput, number of alive and dead nodes. MCH-EOR is found to perform better than the compared protocols. For 500 SNs, MCH-EOR consumes a maximum of 0.34J for 100 sensor nodes and 1.67J of energy for 500 sensor nodes. In contrast, other approaches GWO App., GASONEC, SMEER, and TPSO-CR utilize 0.42, 0.45, 0.46, and 0.5 joules energy, respectively, for 100 sensor nodes and 1.69, 1.74, 1.79 and 1.83 joule of energy for 500 sensor nodes. MCH-EOR has 21% alive node and 87% dead node after 3500 round and is comparatively good. It shows a throughput of 90% for 100 nodes and 85% for 500 nodes deployment. The packet delivery ratio of MCH-EOR is approximately 88.4% for 500 sensor nodes. Also, MCH-EOR can sustain for about 1700 and 3500 rounds with 100 and 500 sensor nodes, respectively.

The LBNR-LEACH is an improvement to the node ranking algorithm called NR-LEACH. The NR-LEACH considers node connectivity and link importance to select a CH. The improved LBNR-LEACH added a feature of network load estimation in each round. This protocol thus selects the best suitable CH among the available candidate CHs. After the node ranking the network load of candidate CHs is computed by energy consumption estimation.

7.2 Future Scope

A WSN has limited energy, computational resources, and limited memory; hence is not so secure. Integrating sensor nodes into public environments without proper protection and connecting to Internet can raise privacy concerns. The proposed protocols can be extended

to take care of potential privacy concerns and may be extended to IoT-based applications. With the advancement in technology, energy harvesting sensors are becoming more prevalent. The impact of applying proposed protocols on energy harvesting sensor nodes needs to be analyzed further and may require to be modified to achieve even higher energy efficiency.

Further, the sensor nodes and base station have been assumed to be static in the proposed approaches. Therefore, the mobility of sensor nodes and mobile sink nodes has not been considered. However, the mobility of sensors and mobile sink may positively impact the energy efficiency of a routing protocol. Thus, the proposed routing protocols using mobile sensor nodes and sink may be considered, and accordingly, the protocols may be modified.

Bibliography

- [1] I. Mahgoub and M. Ilyas, *Smart dust: Sensor network applications, architecture and design*. 2016.
- [2] Y. M. Huang, M. Y. Hsieh, and F. E. Sandnes, “Wireless sensor networks and applications,” *Lect. Notes Electr. Eng.*, vol. 21 LNEE, no. June, pp. 199–219, 2008, doi: 10.1007/978-3-540-69033-7_10.
- [3] H. Mostafaei, “Energy-efficient algorithm for reliable routing of wireless sensor networks,” *IEEE Trans. Ind. Electron.*, vol. 66, no. 7, pp. 5567–5575, 2019, doi: 10.1109/TIE.2018.2869345.
- [4] C. Y. Chong and S. P. Kumar, “Sensor networks: Evolution, opportunities, and challenges,” *Proc. IEEE*, vol. 91, no. 8, pp. 1247–1256, 2003, doi: 10.1109/JPROC.2003.814918.
- [5] Y. M. Liu, S. C. Wu, and X. H. Nian, “The architecture and characteristics of wireless sensor network,” *ICCTD 2009 - 2009 Int. Conf. Comput. Technol. Dev.*, vol. 1, no. 561, pp. 561–565, 2009, doi: 10.1109/ICCTD.2009.44.
- [6] B. G. Paik, S. R. Cho, B. J. Park, D. Lee, B. D. Bae, and J. H. Yun, “Characteristics of wireless sensor network for full-scale ship application,” *J. Mar. Sci. Technol.*, vol. 14, no. 1, pp. 115–126, 2009, doi: 10.1007/s00773-008-0038-x.
- [7] J. N. Al-Karaki and A. E. Kamal, “Routing techniques in wireless sensor networks: A survey,” *IEEE Wirel. Commun.*, vol. 11, no. 6, pp. 6–27, 2004, doi: 10.1109/MWC.2004.1368893.
- [8] C. M. De Farias *et al.*, “A Systematic Review of Shared Sensor Networks,” *ACM Comput. Surv.*, vol. 48, no. 4, 2016, doi: 10.1145/2851510.
- [9] L. Cui, F. Wang, H. Luo, H. Ju, and T. Li, “1 The Concept of Sensor Node Architecture,” pp. 1–3.
- [10] M. S. P. Fonseca, A. Munaretto, C. Mendes, and H. Chaouchi, “A resource management framework for 802.11 wireless access networks,” *Wirel. Networks*, vol. 21, no. 6, pp. 1891–1898, 2015, doi: 10.1007/s11276-015-0893-4.
- [11] S. Verma, N. Sood, and A. K. Sharma, “Design of a novel routing architecture for harsh environment monitoring in heterogeneous WSN,” *IET Wirel. Sens. Syst.*, vol. 8, no. 6, pp. 284–294, 2018, doi: 10.1049/iet-wss.2018.5025.
- [12] I. F. Akyildiz, W. Su, Y. Sankarasubramaniam, and E. Cayirci, “Wireless sensor

-
- networks: A survey,” *Comput. Networks*, vol. 38, no. 4, pp. 393–422, 2002, doi: 10.1016/S1389-1286(01)00302-4.
- [13] Al-Karaki J.N and Kamal A.E, “Wireless Sensor Networks Routing Techniques in Wireless Sensor Networks : a Survey,” *Ieee Wirel. Commun.*, no. 12, pp. 6–28, 2004.
- [14] D. Diamond, K. T. Lau, S. Brady, and J. Cleary, “Integration of analytical measurements and wireless communications–Current issues and future strategies,” *Talanta*, vol. 75, no. 3, pp. 606–612, 2008, doi: 10.1016/j.talanta.2007.11.022.
- [15] J. Zheng and A. Jamalipour, *Wireless Sensor Networks: A Networking Perspective*. 2008.
- [16] A. A. Abbasi and M. Younis, “A survey on clustering algorithms for wireless sensor networks,” *Comput. Commun.*, vol. 30, no. 14–15, pp. 2826–2841, 2007, doi: 10.1016/j.comcom.2007.05.024.
- [17] M. K. Singh, S. I. Amin, S. A. Imam, V. K. Sachan, and A. Choudhary, “A Survey of Wireless Sensor Network and its types,” *Proc. - IEEE 2018 Int. Conf. Adv. Comput. Commun. Control Networking, ICACCCN 2018*, pp. 326–330, 2018, doi: 10.1109/ICACCCN.2018.8748710.
- [18] J. Yick, B. Mukherjee, and D. Ghosal, “Wireless sensor network survey,” *Comput. Networks*, vol. 52, no. 12, pp. 2292–2330, 2008, doi: 10.1016/j.comnet.2008.04.002.
- [19] D. Trincherro, B. Fiorelli, A. Galardini, and R. Stefanelli, “Underground wireless sensor networks,” *2009 IEEE 10th Annu. Wirel. Microw. Technol. Conf. WAMICON 2009*, no. May 2009, 2009, doi: 10.1109/WAMICON.2009.5207281.
- [20] M. A. Akkaş and R. Sokullu, “Wireless underground sensor networks: Channel modeling and operation analysis in the terahertz band,” *International Journal of Antennas and Propagation*, vol. 1, 2015, doi: 10.1155/2015/780235.
- [21] J. Lloret, “Underwater sensor nodes and networks,” *Sensors (Switzerland)*, vol. 13, no. 9, pp. 11782–11796, 2013, doi: 10.3390/s130911782.
- [22] K. M. Awan, P. A. Shah, K. Iqbal, S. Gillani, W. Ahmad, and Y. Nam, “Underwater Wireless Sensor Networks: A Review of Recent Issues and Challenges,” *Wirel. Commun. Mob. Comput.*, vol. 1, 2019, doi: 10.1155/2019/6470359.
- [23] M. Usman, M. A. Jan, X. He, and P. Nanda, “Data sharing in secure multimedia wireless sensor networks,” *Proc. - 15th IEEE Int. Conf. Trust. Secur. Priv. Comput. Commun. 10th IEEE Int. Conf. Big Data Sci. Eng. 14th IEEE Int. Symp. Parallel Distrib. Proce*, pp. 590–597, 2016, doi: 10.1109/TrustCom.2016.0114.
- [24] I. F. Akyildiz, T. Melodia, and K. R. Chowdhury, “Wireless multimedia sensor
-

-
- networks: applications and testbeds,” *Proc. IEEE*, vol. 96, no. 10, pp. 1588–1605, 2008, doi: 10.1109/JPROC.2008.928756.
- [25] A. U. H. Yasar, H. Malik, and Z. Khan, “Editorial: Mobile Sensor Networks Applications and Confidentiality,” *Mob. Inf. Syst.*, vol. 2015, pp. 2–4, 2015, doi: 10.1155/2015/893438.
- [26] W. Li *et al.*, “Efficient allocation of resources in multiple heterogeneous Wireless Sensor Networks,” *J. Parallel Distrib. Comput.*, vol. 74, no. 1, pp. 1775–1788, 2014, doi: 10.1016/j.jpdc.2013.09.012.
- [27] S. R. Jino Ramson and D. Jackuline Moni, “Applications of Wireless Sensor Networks - A survey,” *Proc. IEEE Int. Conf. Innov. Electr. Electron. Instrum. Media Technol. ICIEEIMT 2017*, vol. 2017-Janua, no. 978, pp. 325–329, 2017, doi: 10.1109/.2005.1467103.
- [28] A. Ali, Y. Ming, S. Chakraborty, and S. Iram, “A comprehensive survey on real-time applications of WSN,” *Futur. Internet*, vol. 9, no. 4, 2017, doi: 10.3390/fi9040077.
- [29] S. Kumar and L. Purohit, “Exploring K-means clustering and skyline for web service selection,” *11th Int. Conf. Ind. Inf. Syst. ICIIS 2016 - Conf. Proc.*, vol. 2018-Janua, pp. 603–607, 2016, doi: 10.1109/ICIINFS.2016.8263010.
- [30] M. Alowaidi, A. Karime, M. Aljaafrah, and A. El Saddik, “Empirical study of noise and air quality correlation based on IoT sensory platform approach,” *I2MTC 2018 - 2018, IEEE Int. Instrum. Meas. Technol. Conf. Discov. New Horizons Instrum. Meas. Proc.*, pp. 1–6, 2018, doi: 10.1109/I2MTC.2018.8409629.
- [31] G. Gupta, “Load-balanced clustering of wireless sensor networks,” *IEEE Int. Conf. Commun.*, vol. 3, pp. 1848–1852, 2003, doi: 10.1109/icc.2003.1203919.
- [32] A. Belghith and M. S. Obaidat, *Wireless sensor networks applications to smart homes and cities*. Elsevier Inc., 2016.
- [33] A. Darwish and A. E. Hassanien, “Wearable and implantable wireless sensor network solutions for healthcare monitoring,” *Sensors*, vol. 11, no. 6, pp. 5561–5595, 2011, doi: 10.3390/s110605561.
- [34] R. Punj and R. Kumar, *Technological aspects of WBANs for health monitoring: a comprehensive review*, vol. 25, no. 3. Springer US, 2019.
- [35] C. Mishra and D. L. Gupta, “Deep Machine Learning and Neural Networks: An Overview,” *IAES Int. J. Artif. Intell.*, vol. 6, no. 2, p. 66, 2017, doi: 10.11591/ijai.v6.i2.pp66-73.
- [36] M. Carlos-Mancilla, E. López-Mellado, and M. Siller, “Wireless sensor networks
-

-
- formation: Approaches and techniques,” *J. Sensors*, vol. 1, 2016, doi: 10.1155/2016/2081902.
- [37] F. Hidoussi *et al.*, “PEAL: Power Efficient and Adaptive Latency Hierarchical Routing Protocol for Cluster-Based WSN,” *Wirel. Pers. Commun.*, vol. 96, no. 4, pp. 4929–4945, 2017, doi: 10.1007/s11277-017-4963-z.
- [38] A. Diop, Y. Qi, Q. Wang, and S. Hussain, “An Efficient and Secure Key Management Scheme for Hierarchical Wireless Sensor Networks,” *Int. J. Comput. Commun. Eng.*, no. 5, pp. 365–370, 2012, doi: 10.7763/ijcce.2012.v1.91.
- [39] S. Labs, “The Evolution of Wireless Sensor Networks,” pp. 1–5, 2004, [Online]. Available: <http://www.silabs.com/Support Documents/TechnicalDocs/evolution-of-wireless-sensor-networks.pdf>.
- [40] T. Rault, A. Bouabdallah, and Y. Challal, “Energy efficiency in wireless sensor networks: A top-down survey,” *Comput. Networks*, vol. 67, pp. 104–122, 2014, doi: 10.1016/j.comnet.2014.03.027.
- [41] M. Meghji and D. Habibi, “Transmission power control in multihop wireless sensor networks,” *ICUFN 2011 - 3rd Int. Conf. Ubiquitous Futur. Networks*, no. 1, pp. 25–30, 2011, doi: 10.1109/ICUFN.2011.5949130.
- [42] Sohail Jabbar, Muhammad Asif Habib, Abid Ali Minhas, Mudassar Ahmad, Rehan Ashraf, Shehzad Khalid, Kijun Han, "Analysis of Factors Affecting Energy Aware Routing in Wireless Sensor Network", *Wireless Communications and Mobile Computing*, vol. 2018, Article ID 9087269, pages 21, 2018. <https://doi.org/10.1155/2018/9087269>.
- [43] S. Taruna, Megha R. Tiwari, 2013, An Event Driven Energy Efficient Data Reporting System for Wireless Sensor Network, *International Journal Of Engineering Research & Technology (IJERT)* Volume 02, Issue 02 (February 2013),
- [44] A. K. Mahmoud, M. E. Khedr, and S. Shaaban, “Hexagonal two tier data dissemination model for large scale wireless sensor networks,” *Proc. 2012 Japan-Egypt Conf. Electron. Commun. Comput. JEC-ECC 2012*, pp. 138–144, 2012, doi: 10.1109/JEC-ECC.2012.6186972.
- [45] Y. Singh, J. A. Lone, P. K. Singh, Z. Polkowski, S. Tanwar, and S. Tyagi, “Deployment and Coverage in Wireless Sensor Networks: A Perspective,” *Proc. 11th Int. Conf. Electron. Comput. Artif. Intell. ECAI 2019*, 2019, doi: 10.1109/ECAI46879.2019.9042091.
- [46] R. Aquino-Santos, L. Villasenor-Gonzalez, J. Sanchez, and J. R. Gallardo, “Routing
-

-
- strategies for wireless sensor networks,” *IFIP Int. Fed. Inf. Process.*, vol. 248, pp. 191–202, 2007, doi: 10.1007/978-0-387-74899-3_17.
- [47] L. J. G. Villalba, A. L. S. Orozco, A. T. Cabrera, and C. J. B. Abbas, “Routing protocols in wireless sensor networks,” *Sensors*, vol. 9, no. 11, pp. 8399–8421, 2009, doi: 10.3390/s91108399.
- [48] H. Patel, D. Singh Rajput, G. Thippa Reddy, C. Iwendi, A. Kashif Bashir, and O. Jo, “A review on classification of imbalanced data for wireless sensor networks,” *Int. J. Distrib. Sens. Networks*, vol. 16, no. 4, 2020, doi: 10.1177/1550147720916404.
- [49] J. Govindasamy and S. Punniakody, “A comparative study of reactive, proactive and hybrid routing protocol in wireless sensor network under wormhole attack,” *J. Electr. Syst. Inf. Technol.*, vol. 5, no. 3, pp. 735–744, 2018, doi: 10.1016/j.jesit.2017.02.002.
- [50] A. Shahraki, A. Taherkordi, Haugen, and F. Eliassen, “Clustering objectives in wireless sensor networks: A survey and research direction analysis,” *Comput. Networks*, vol. 180, no. March, 2020, doi: 10.1016/j.comnet.2020.107376.
- [51] N. Shabbir and S. R. Hassan, “Routing Protocols for Wireless Sensor Networks (WSNs),” *Wirel. Sens. Networks - Insights Innov.*, 2017, doi: 10.5772/intechopen.70208.
- [52] M. Masonta, Y. Haddad, L. De Nardis, A. Kliks, and O. Holland, “Energy efficiency in future wireless networks: Cognitive radio standardization requirements,” *2012 IEEE 17th Int. Work. Comput. Aided Model. Des. Commun. Links Networks, CAMAD 2012*, pp. 31–35, 2012, doi: 10.1109/CAMAD.2012.6335359.
- [53] M. Aishwarya and S. Kirthiga, “Relay Assisted Cooperative Communication for Wireless Sensor Networks,” *Proc. 2018 2nd Int. Conf. Adv. Electron. Comput. Commun. ICAECC 2018*, vol. 1, pp. 1–6, 2018, doi: 10.1109/ICAIECC.2018.8479524.
- [54] H. N. Dai, “Throughput and delay in wireless sensor networks using directional antennas,” *ISSNIP 2009 - Proc. 2009 5th Int. Conf. Intell. Sensors, Sens. Networks Inf. Process.*, no. 2, pp. 421–426, 2009, doi: 10.1109/ISSNIP.2009.5416826.
- [55] L. H. A. Correia, D. F. Macedo, A. L. dos Santos, A. A. F. Loureiro, and J. M. S. Nogueira, “Transmission power control techniques for wireless sensor networks,” *Comput. Networks*, vol. 51, no. 17, pp. 4765–4779, 2007, doi: 10.1016/j.comnet.2007.07.008.
- [56] X. Chu and H. Sethu, “Cooperative Topology Control with Adaptation for Improved
-

-
- Lifetime in Wireless Ad Hoc Networks,” no 1, pp. 262–270, 2012.
- [57] G. Anastasi, M. Conti, M. Di, and A. Passarella, “Ad Hoc Networks Energy conservation in wireless sensor networks : A survey,” *Ad Hoc Networks*, vol. 7, no. 3, pp. 537–568, 2009, doi: 10.1016/j.adhoc.2008.06.003.
- [58] E. M. Lee, A. Kashif, D. H. Lee, I. T. Kim, and M. S. Park, “Location based multi-queue scheduler in wireless sensor network,” *Int. Conf. Adv. Commun. Technol. ICACT*, vol. 1, pp. 551–555, 2010.
- [59] H. Ba, I. Demirkol, and W. Heinzelman, “Ad Hoc Networks Passive wake-up radios : From devices to applications,” vol. 11, pp. 2605–2621, 2013, doi: 10.1016/j.adhoc.2013.08.004.
- [60] E. Karasabun, I. Korpeoglu, and C. Aykanat, “Active node determination for correlated data gathering in wireless sensor networks,” *Comput. Networks*, vol. 57, no. 5, pp. 1124–1138, 2013, doi: 10.1016/j.comnet.2012.11.018.
- [61] K. Akkaya, M. Younis, A survey on routing protocols for wireless sensor networks, *Ad Hoc Netw.* 3 (3) (2005) 325–349.
- [62] K. T. Kim, C. H. Lyu, S. S. Moon, and H. Y. Youn, “Tree-based clustering(TBC) for energy efficient wireless sensor networks,” *24th IEEE Int. Conf. Adv. Inf. Netw. Appl. Work. WAINA 2010*, pp. 680–685, 2010, doi: 10.1109/WAINA.2010.62.
- [63] A. Liu, J. Ren, X. Li, Z. Chen, X.S. Shen, Design principles and improvement of cost function based energy aware routing algorithms for wireless sensor networks, *Comput. Netw.* 56 (7) (2012) 1951–1967.
- [64] P. Seal, M. Chatterjee, and T. Samanta, “Robust Energy Efficient Multipath Routing Protocol for Wireless Sensor Networks,” *Proc. - 2015 IEEE Int. Symp. Nanoelectron. Inf. Syst. iNIS 2015*, pp. 35–40, 2016, doi: 10.1109/iNIS.2015.11.
- [65] M. Younis, K. Akkaya, Strategies and techniques for node placement in wireless sensor networks: a survey, *Ad Hoc Netw.* 6 (4) (2008) 621–655.
- [66] S. Ergen, P. Varaiya, Optimal placement of relay nodes for energy efficiency in sensor networks, in: *IEEE Int. Conf. on Communications*, Istanbul, 2006, pp. 3473–479.
- [67] S. Misra, N.E. Majd, H. Huang, Constrained relay node placement in energy harvesting wireless sensor networks, in: *IEEE 8th Int. Conf. on Mobile Adhoc and Sensor Systems*, Valencia, 2011, pp. 2155–6806.
- [68] M. Di Francesco, S.K. Das, G. Anastasi, Data collection in wireless sensor networks with mobile elements, *ACM Trans. Sensor Netw.* 8 (1) (2011) 1–34.
-

-
- [69] S. Sudevalayam and P. Kulkarni, "Energy harvesting sensor nodes: Survey and implications," *IEEE Commun. Surv. Tutorials*, vol. 13, no. 3, pp. 443–461, 2011, doi: 10.1109/SURV.2011.060710.00094.
- [70] P. Nintanavongsa, M. Y. Naderi, and K. R. Chowdhury, "Medium access control protocol design for sensors powered by wireless energy transfer," *Proc. - IEEE INFOCOM*, pp. 150–154, 2013, doi: 10.1109/INFCOM.2013.6566753.
- [71] K. Tutuncuoglu, A. Yener, and S. Ulukus, "Optimum Policies for an Energy Harvesting Transmitter under Energy Storage Losses," *IEEE J. Sel. Areas Commun.*, vol. 33, no. 3, pp. 467–481, 2015, doi: 10.1109/JSAC.2015.2391511.
- [72] L. Xie, Y. Shi, Y. Hou, A. Lou, Wireless power transfer and applications to sensor networks, *IEEE Wireless Commun.* 20 (4) (2013) 140–145.
- [73] F. Zhang, S.A. Hackworth, X. Liu, H. Chen, S.R.J.M. Sun, Wireless energy transfer platform for medical sensors and implantable devices, in: *Int. Conf. of the IEEE Engineering in Medicine and Biology Society*, Minneapolis, MN, 2012, pp. 1045–1048.
- [74] O. Jonah and S. V. Georgakopoulos, "Efficient wireless powering of sensors embedded in concrete via magnetic resonance," *IEEE Antennas Propag. Soc. AP-S Int. Symp.*, no 1, pp. 1425–1428, 2011, doi: 10.1109/APS.2011.5996560.
- [75] B. Griffin and C. Detweiler, "Resonant wireless power transfer to ground sensors from a UAV," *Proc. - IEEE Int. Conf. Robot. Autom.*, no 1, pp. 2660–2665, 2012, doi: 10.1109/ICRA.2012.6225205.
- [76] B. Gurakan, O. Ozel, J. Yang, and S. Ulukus, "Energy cooperation in energy harvesting communications," *IEEE Trans. Commun.*, vol. 61, no. 12, pp. 4884–4898, 2013, doi: 10.1109/TCOMM.2013.110113.130184.
- [77] Q. Zia, "A Survey of Data-Centric Protocols for Wireless Sensor Networks," *J. Comput. Sci. Syst. Biol.*, vol. 8, no. 3, 2015, doi: 10.4172/jcsb.1000180.
- [78] D. Mehta and S. Saxena, "A Comparative Analysis of Energy Efficient Hierarchical Routing Protocols for Wireless Sensor Networks," *Proc. - 4th Int. Conf. Comput. Sci. ICCS 2018*, no 1, pp. 53–58, 2019, doi: 10.1109/ICCS.2018.00015.
- [79] W. R. Heinzelman, J. Kulik, and H. Balakrishnan, "Adaptive protocols for information dissemination in wireless sensor networks," pp. 174–185, 1999, doi: 10.1145/313451.313529.
- [80] Chalermek Intanagonwiwat, Ramesh Govindan, and Deborah Estrin. 2000. Directed diffusion: a scalable and robust communication paradigm for sensor networks. In
-

-
- Proceedings of the 6th annual international conference on Mobile computing and networking (MobiCom '00). Association for Computing Machinery, New York, NY, USA, 56–67. DOI:<https://doi.org/10.1145/345910.345920>
- [81] J. M. Rabaey, M. J. Ammer, J. L. Da Silva, D. Patel, and S. Roundy, “PicoRadio supports ad hoc ultra-low power wireless networking,” *Computer (Long. Beach. Calif.)*, vol. 33, no. 7, pp. 42–48, 2000, doi: 10.1109/2.869369.
- [82] W. R. Heinzelman, A. Sinha, A. Wang, and A. P. Chandrakasan, “Energy-scalable algorithms and protocols for wireless microsensor networks,” *ICASSP, IEEE Int. Conf. Acoust. Speech Signal Process. - Proc.*, vol. 6, pp. 3722–3725, 2000, doi: 10.1109/ICASSP.2000.860211.
- [83] R. C. Shah and J. M. Rabaey, “Energy aware routing for low energy ad hoc sensor networks,” *IEEE Wirel. Commun. Netw. Conf. WCNC*, vol. 1, pp. 350–355, 2002, doi: 10.1109/WCNC.2002.993520.
- [84] D. Braginsky and D. Estrin, “Rumor routing algorithm for sensor networks,” *Proc. ACM Int. Work. Wirel. Sens. Networks Appl.*, no 1, pp. 22–31, 2002, doi: 10.1145/570739.570742.
- [85] Chu M, Haussecker H, Zhao F. "Scalable Information-Driven Sensor Querying and Routing for Ad Hoc Heterogeneous Sensor Networks", *The International Journal of High Performance Computing Applications*, no 3, vol 16, pp 293-313, 2002. doi:10.1177/10943420020160030901
- [86] Y. Yao and J. Gehrke, “The cougar approach to in-network query processing in sensor networks,” *SIGMOD Rec.*, vol. 31, no. 3, pp. 9–18, 2002, doi: 10.1145/601858.601861.
- [87] N. Sadagopan, B. Krishnamachari, and A. Helmy, “The ACQUIRE mechanism for efficient querying in sensor networks,” *Proc. 1st IEEE Int. Work. Sens. Netw. Protoc. Appl. SNPA 2003*, pp. 149–155, 2003, doi: 10.1109/SNPA.2003.1203365.
- [88] P. Karkazis, H. C. Leligou, T. Orphanoudakis, and T. Zahariadis, “Geographical routing in wireless sensor networks,” *2012 Int. Conf. Telecommun. Multimedia, TEMU 2012*, no. 9, pp. 19–24, 2012, doi: 10.1109/TEMU.2012.6294717.
- [89] V. Rodoplu and T. H. Meng, “Minimum energy mobile wireless networks,” *Int. Conf. Commun. - Proc.*, vol. 3, pp. 1633–1639, 1998, doi: 10.1109/ICC.1998.683107.
- [90] L. Li and J. Y. Halpern, “Minimum-energy mobile wireless networks revisited,” *IEEE Int. Conf. Commun.*, vol. 1, pp. 278–283, 2001, doi: 10.1109/icc.2001.936317.
-

-
- [91] Y. Xu, J. Heidemann, and D. Estri, "Geography-informed Energy Conservation," *Proc. 7th Annu. Int. Conf. Mob. Comput. Netw.*, pp. 70–84, 2001, [Online]. Available: <http://portal.acm.org/citation.cfm?doid=381677.381685>.
- [92] Y. Yu, R. Govindan, and D. Estrin, *Geographical and Energy Aware Routing: A Recursive Data Dissemination Protocol for Wireless Sensor Networks*, 2001.
- [93] X. Ning and C. G. Cassandras, "On maximum lifetime routing in wireless sensor networks," *Proc. IEEE Conf. Decis. Control*, vol. 12, no. 4, pp. 3757–3762, 2009, doi: 10.1109/CDC.2009.5400394.
- [94] K. Kalpakis, K. Dasgupta, and P. Namjoshi, "Maximum Lifetime Data Gathering and Aggregation In Wireless Sensor Networks," in *Networks*, no 8, 2002, pp. 685–696, doi: 10.1142/9789812776730_0055
- [95] S. Lindsey, C. Raghavendra, and K. Sivalingam, "Data gathering in sensor networks using the energy*delay metric," *Proc. - 15th Int. Parallel Distrib. Process. Symp. IPDPS 2001*, vol. 00, no. C, pp. 2001–2008, 2001, doi: 10.1109/IPDPS.2001.925196.
- [96] F. Ye et al., A scalable solution to minimum cost forwarding in large scale sensor networks, in: *Proceedings of International Conference on Computer Communications and Networks (ICCCN)*, Dallas, TX, October 2001.
- [97] G. Sun, J. Qi, Z. Zang, and Q. Xu, "A reliable multipath routing algorithm with related congestion control scheme in wireless multimedia sensor networks," *ICCRD2011 - 2011 3rd Int. Conf. Comput. Res. Dev.*, vol. 4, pp. 229–233, 2011, doi: 10.1109/ICCRD.2011.5763902.
- [98] K. Sohrabi, J. Gao, V. Ailawadhi, and G. J. Pottie, "Protocols for Self-Organization of a WSN," *Ieee Pers. Commun.*, no. October, pp. 16–27, 2000.
- [99] K. Akkaya, M. Younis, An energy-aware QoS routing protocol for wireless sensor networks, in: *Proceedings of the IEEE Workshop on Mobile and Wireless Networks*
- [100] T. He, J. A. Stankovic, C. Lu, and T. Abdelzaher, "SPEED: A stateless protocol for real-time communication in sensor networks," *Proc. - Int. Conf. Distrib. Comput. Syst.*, pp. 46–55, 2003, doi: 10.1109/icdcs.2003.1203451.
- [101] D. B. Johnson and D. A. Maltz, "Dynamic Source Routing in Ad Hoc Wireless Networks," *Mob. Comput.*, no 1, pp. 153–181, 2007, doi: 10.1007/978-0-585-29603-6_5.
- [102] Perkins, Charles & Belding, Elizabeth & SR, Das. (2002). Ad hoc on-demand distance vector (AODV) routing. IETF. 3561. 10.17487/RFC3561.
-

-
- [103] M. K. Khan *et al.*, “Hierarchical Routing Protocols for Wireless Sensor Networks: Functional and Performance Analysis,” *J. Sensors*, vol. 2021, pp. 1–18, 2021, doi: 10.1155/2021/7459368.
- [104] L. Purohit and S. Kumar, “Clustering based approach for web service selection using skyline computations,” *Proc. - 2019 IEEE Int. Conf. Web Serv. ICWS 2019 - Part 2019 IEEE World Congr. Serv.*, vol. 1, pp. 260–264, 2019, doi: 10.1109/ICWS.2019.00052.
- [105] A. Anhar and R. Nilavalan, *Multi-hop hierarchical routing based on the node health status in wireless sensor network*, vol. 857. Springer International Publishing, 2019.
- [106] S. Pal, D. Bhattacharyya, and T. H. Kim, “Chain based hierarchical routing protocol for wireless sensor networks,” *Commun. Comput. Inf. Sci.*, vol. 78 CCIS, pp. 482–492, 2010, doi: 10.1007/978-3-642-16444-6_61.
- [107] S. Lindsey and C. S. Raghavendra, “PEGASIS: Power-efficient gathering in sensor information systems,” *IEEE Aerosp. Conf. Proc.*, vol. 3, pp. 1125–1130, 2002, doi: 10.1109/AERO.2002.1035242.
- [108] A. K. Mishra, R. U. Rahman, R. Bharadwaj, and R. Sharma, “An enhancement of PEGASIS protocol with improved network lifetime for Wireless Sensor Networks,” *2015 IEEE Power, Commun. Inf. Technol. Conf. PCITC 2015 - Proc.*, pp. 142–147, 2016, doi: 10.1109/PCITC.2015.7438149.
- [109] S. Lindsey, C. Raghavendra, and K. M. Sivalingam, “Data gathering algorithms in sensor networks using energy metrics,” *IEEE Trans. Parallel Distrib. Syst.*, vol. 13, no. 9, pp. 924–935, 2002, doi: 10.1109/TPDS.2002.1036066.
- [110] R. Dutta and S. Gupta, “Energy aware modified PEGASIS through packet transmission in wireless sensor network,” in *2016 Fourth International Conference on Parallel, Distributed and Grid Computing (PDGC)*, 2016, pp. 443–446, doi: 10.1109/PDGC.2016.7913236.
- [111] S. M. Jung, Y. J. Han, and T. M. Chung, “The concentric clustering scheme for efficient energy consumption in the PEGASIS,” *Int. Conf. Adv. Commun. Technol. ICACT*, vol. 1, pp. 260–265, 2007, doi: 10.1109/ICACTION.2007.358351.
- [112] B. Xi-rong, Z. Shi, X. Ding-yu, and Q. Zhi-tao, “An energy-balanced chain-cluster routing protocol for wireless sensor networks,” *NSWCTC 2010 - 2nd Int. Conf. Networks Secur. Wirel. Commun. Trust. Comput.*, vol. 2, pp. 79–84, 2010, doi: 10.1109/NSWCTC.2010.155.
- [113] K. H. Chen, J. M. Huang, and C. C. Hsiao, “CHIRON: An energy-efficient Chain-

-
- Based Hierarchical Routing Protocol in wireless sensor networks,” *2009 Wirel. Telecommun. Symp. WTS 2009*, 2009, doi: 10.1109/WTS.2009.5068960.
- [114] Z. N. Zhao, J. Wang, and H. W. Guo, “A hierarchical adaptive routing algorithm of wireless sensor network based on software-defined network,” *Int. J. Distrib. Sens. Networks*, vol. 14, no. 8, 2018, doi: 10.1177/1550147718794617.
- [115] M. Ding, X. Cheng, and G. Xue, “Aggregation tree construction in sensor networks,” *IEEE Veh. Technol. Conf.*, vol. 58, no. 4, pp. 2168–2172, 2003, doi: 10.1109/vetecf.2003.1285913.
- [116] H. S. Kim and K. J. Han, “A power efficient routing protocol based on balanced tree in wireless sensor networks,” *Proc. - First Int. Conf. Distrib. Fram. Multimed. Appl. 2005, DFMA '05*, vol. 2005, pp. 138–143, 2005, doi: 10.1109/dfma.2005.8.
- [117] L. Subramanian and R. H. Katz, “An architecture for building self-configurable systems,” *2000 1st Annu. Work. Mob. Ad Hoc Netw. Comput. MobiHOC 2000*, pp. 63–73, 2000, doi: 10.1109/MOBHOC.2000.869214.
- [118] H. Ö. Tan and I. Körpeoğlu, “Power efficient data gathering and aggregation in wireless sensor networks,” *SIGMOD Rec.*, vol. 32, no. 4, pp. 66–71, 2003, doi: 10.1145/959060.959072.
- [119] W. Qiu, E. Skafidas, and P. Hao, “Enhanced tree routing for wireless sensor networks,” *Ad Hoc Networks*, vol. 7, no. 3, pp. 638–650, 2009, doi: 10.1016/j.adhoc.2008.07.006.
- [120] U. K. Paul and S. Chattopadhyay, “A novel grid based energy efficient routing algorithm for Wireless Sensor networks,” *Proc. 2016 IEEE Int. Conf. Wirel. Commun. Signal Process. Networking, WiSPNET 2016*, pp. 623–626, 2016, doi: 10.1109/WiSPNET.2016.7566208.
- [121] “PANEL : Position-based Aggregator Node Election in Wireless Sensor Networks * Levente Buttyán and Peter Schaffer Laboratory of Cryptography and Systems Security (CrySyS) Budapest University of Technology and Economics (BME),” 2007.
- [122] H. Luo, F. A. N. Ye, J. Cheng, S. Lu, and L. Zhang, “TTDD : Two-Tier Data Dissemination in Large-Scale Wireless Sensor Networks,” no 1, pp. 161–175, 2005.
- [123] D. Koutsonikolas, S. Das, Y. C. Hu, and I. Stojmenovic, “Hierarchical geographic multicast routing for wireless sensor networks,” *2007 Int. Conf. Sens. Technol. Appl. SENSORCOMM 2007, Proc.*, pp. 347–354, 2007, doi: 10.1109/SENSORCOMM.2007.4394946.
-

-
- [124] O. Banimelhem and S. Khasawneh, "GMCAR: Grid-based multipath with congestion avoidance routing protocol in wireless sensor networks," *Ad Hoc Networks*, vol. 10, no. 7, pp. 1346–1361, 2012, doi: 10.1016/j.adhoc.2012.03.015.
- [125] W. Ke, O. Yangrui, J. Hong, Z. Heli, and L. Xi, "Energy aware hierarchical cluster-based routing protocol for WSNs," *J. China Univ. Posts Telecommun.*, vol. 23, no. 4, pp. 46–52, 2016, doi: 10.1016/S1005-8885(16)60044-4.
- [126] E. Ben Hamida and G. Chelius, "A line-based data dissemination protocol for wireless sensor networks with mobile sink," *IEEE Int. Conf. Commun.*, pp. 2201–2205, 2008, doi: 10.1109/ICC.2008.420.
- [127] C. Tunca and M. Y. D., "Uml ' C " G Halka Y Onlend Irme : Hareketli , Ikis , D U ' , in ' Enerji I ' G Ozeten ' Protokol Algilayici a Glar Ic B Ir Ring Routing : an Energy-Efficient Routing Protocol for Wireless Sensor Networks With a Mobile Sink , E," pp. 8–11, 2012.
- [128] J. H. Shin, J. Kim, K. Park, and D. Park, "Railroad: Virtual infrastructure for data dissemination in wireless sensor networks," *PE-WASUN'05 - Proc. Second ACM Int. Work. Perform. Eval. Wirel. Ad Hoc, Sensor, Ubiquitous Networks*, pp. 168–174, 2005.
- [129] H. S. Mo, E. Lee, S. Park, and S. H. Kim, "Virtual line-based data dissemination for mobile sink groups in wireless sensor networks," *IEEE Commun. Lett.*, vol. 17, no. 9, pp. 1864–1867, 2013, doi: 10.1109/LCOMM.2013.072913.131354.
- [130] R. Zagrouba and A. Kardi, "Comparative study of energy efficient routing techniques in wireless sensor networks," *Inf.*, vol. 12, no. 1, pp. 1–28, 2021, doi: 10.3390/info12010042.
- [131] W. R. Heinzelman, A. Chandrakasan and H. Balakrishnan, "Energy-efficient communication protocol for wireless microsensor networks," Proceedings of the 33rd Annual Hawaii International Conference on System Sciences, 2000, pp. 10 pp. vol.2-, doi: 10.1109/HICSS.2000.926982.
- [132] M. S. Ali, T. Dey, and R. Biswas, "ALEACH: Advanced LEACH routing protocol for wireless microsensor networks," *Proc. ICECE 2008 - 5th Int. Conf. Electr. Comput. Eng.*, vol. 00, no. December 2008, pp. 909–914, 2008, doi: 10.1109/ICECE.2008.4769341.
- [133] T. Mu and M. Tang, "LEACH-B: An improved LEACH protocol for wireless sensor network," *2010 6th Int. Conf. Wirel. Commun. Netw. Mob. Comput. WiCOM 2010*, pp. 2–5, 2010, doi: 10.1109/WICOM.2010.5601113.
-

-
- [134] R. Mehta, A. Pandey, and P. Kapadia, "Reforming clusters using C-LEACH in Wireless Sensor Networks," *2012 Int. Conf. Comput. Commun. Informatics, ICCCI 2012*, pp. 10–13, 2012, doi: 10.1109/ICCCI.2012.6158875.
- [135] M. Tripathi, R. B. Battula, M. S. Gaur, and V. Laxmi, "Energy efficient clustered routing for wireless sensor network," *Proc. - IEEE 9th Int. Conf. Mob. Ad-Hoc Sens. Networks, MSN 2013*, no. December, pp. 330–335, 2013, doi: 10.1109/MSN.2013.67.
- [136] M. J. Handy, M. Haase, and D. Timmermann, "Low energy adaptive clustering hierarchy with deterministic cluster-head selection," *2002 4th Int. Work. Mob. Wirel. Commun. Network, MWCN 2002*, pp. 368–372, 2002, doi: 10.1109/MWCN.2002.1045790.
- [137] J. Xu, N. Jin, X. Lou, T. Peng, Q. Zhou, and Y. Chen, "Improvement of LEACH protocol for WSN," *Proc. - 2012 9th Int. Conf. Fuzzy Syst. Knowl. Discov. FSKD 2012*, no. Fskd, pp. 2174–2177, 2012, doi: 10.1109/FSKD.2012.6233907.
- [138] A. Azim and M. M. Islam, "Hybrid LEACH: A relay node based low energy adaptive clustering hierarchy for wireless sensor networks," *Proc. - MICC 2009 2009 IEEE 9th Malaysia Int. Conf. Commun. with a Spec. Work. Digit. TV Contents*, no. December, pp. 911–916, 2009, doi: 10.1109/MICC.2009.5431462.
- [139] Z. Beiranvand, A. Patooghy, and M. Fazeli, "I-LEACH: An efficient routing algorithm to improve performance & to reduce energy consumption in wireless sensor networks," *IKT 2013 - 2013 5th Conf. Inf. Knowl. Technol.*, pp. 13–18, 2013, doi: 10.1109/IKT.2013.6620030.
- [140] Y. Li, L. Ding, and F. Liu, "The improvement of LEACH protocol in WSN," *Proc. 2011 Int. Conf. Comput. Sci. Netw. Technol. ICCSNT 2011*, vol. 2, pp. 1345–1348, 2011, doi: 10.1109/ICCSNT.2011.6182209.
- [141] K. Y. Jin, Y. Zhang, and D. R. Tian, "Based on the improvement of LEACH protocol for wireless sensor network routing algorithm," *Proc. - 2012 Int. Conf. Intell. Syst. Des. Eng. Appl. ISDEA 2012*, pp. 1525–1528, 2012, doi: 10.1109/ISdea.2012.728.
- [142] B. Manzoor *et al.*, "Q-LEACH: A new routing protocol for WSNs," *Procedia Comput. Sci.*, vol. 19, pp. 926–931, 2013, doi: 10.1016/j.procs.2013.06.127.
- [143] A. Wang, D. Yang, and D. Sun, "A clustering algorithm based on energy information and cluster heads expectation for wireless sensor networks," *Comput. Electr. Eng.*, vol. 38, no. 3, pp. 662–671, 2012, doi: 10.1016/j.compeleceng.2011.11.017.
- [144] R. Hou, W. Ren, and Y. Zhang, "A wireless sensor network clustering algorithm
-

-
- based on energy and distance,” *2nd Int. Work. Comput. Sci. Eng. WCSE 2009*, vol. 1, no. 1, pp. 439–442, 2009, doi: 10.1109/WCSE.2009.705.
- [145] A. Al-Baz and A. El-Sayed, “A new algorithm for cluster head selection in LEACH protocol for wireless sensor networks,” *Int. J. Commun. Syst.*, vol. 31, no. 1, p. e3407, Jan. 2018, doi: 10.1002/dac.3407.
- [146] N. M.Nawar, S. E. Soliman, N. M.Ayad, H. S. El-Sayed, and M. H. Kelash, “Enhancement of Mobility Model for Cluster Hierarchical Routing Protocol in Wireless Sensor Networks,” *Int. J. Comput. Appl.*, vol. 94, no. 9, pp. 12–16, 2014, doi: 10.5120/16370-5543.
- [147] S. Yi, J. Heo, Y. Cho, and J. Hong, “PEACH: Power-efficient and adaptive clustering hierarchy protocol for wireless sensor networks,” *Comput. Commun.*, vol. 30, no. 14–15, pp. 2842–2852, 2007, doi: 10.1016/j.comcom.2007.05.034.
- [148] O. Younis and S. Fahmy, “HEED: A hybrid, energy-efficient, distributed clustering approach for ad hoc sensor networks,” *IEEE Trans. Mob. Comput.*, vol. 3, no. 4, pp. 366–379, 2004, doi: 10.1109/TMC.2004.41.
- [149] A. Manjeshwar and D. P. Agrawal, “TEEN: a routing protocol for enhanced efficiency in wireless sensor networks,” in *Proceedings 15th International Parallel and Distributed Processing Symposium. IPDPS 2001*, no 1, pp. 2009–2015, doi: 10.1109/IPDPS.2001.925197.
- [150] A. Manjeshwar and D. P. Agrawal, “APTEEN: A hybrid protocol for efficient routing and comprehensive information retrieval in wireless,” *Proc. - Int. Parallel Distrib. Process. Symp. IPDPS 2002*, p. 195, 2002, doi: 10.1109/IPDPS.2002.1016600.
- [151] M. Younis, M. Youssef, and K. Arisha, “Energy-aware routing in cluster-based sensor networks,” *Proc. - IEEE Comput. Soc. Annu. Int. Symp. Model. Anal. Simul. Comput. Telecommun. Syst. MASCOTS*, vol. 2002-Janua, no 1, pp. 129–136, 2002, doi: 10.1109/MASCOT.2002.1167069.
- [152] I. Gupta, D. Riordan, and S. Sampalli, “Cluster-head election using fuzzy logic for wireless sensor networks,” *Proc. 3rd Annu. Commun. Networks Serv. Res. Conf.*, vol. 2005, pp. 255–260, 2005, doi: 10.1109/CNSR.2005.27.
- [153] M. R. Minhas, S. Gopalakrishnan, and V. C. M. Leung, “Fuzzy algorithms for maximum lifetime routing in wireless sensor networks,” *GLOBECOM - IEEE Glob. Telecommun. Conf.*, no. Section VI, pp. 94–99, 2008, doi: 10.1109/GLOCOM.2008.ECP.26.
-

-
- [154] M. Kubat, “Neural networks: a comprehensive foundation by Simon Haykin, Macmillan, 1994, ISBN 0-02-352781-7.” *The Knowledge Engineering Review*, vol. 13, no. 4, pp. 409–412, 1999, doi: 10.1017/s0269888998214044.
- [155] J. Barbancho, C. León, J. Molina, and A. Barbancho, “Giving neurons to sensors. QoS management in wireless sensors networks,” *IEEE Int. Conf. Emerg. Technol. Fact. Autom. ETFA*, pp. 597–600, 2006, doi: 10.1109/ETFA.2006.355389.
- [156] A. Bhagat and A. S. Kushwaha, “NHAP-RZLEACH-Based Hybrid Framework to Enhance Network Lifetime in Wireless Sensor Networks,” 2021, pp. 413–424.
- [157] B. Baranidharan and B. Santhi, “GAECH: Genetic algorithm based energy efficient clustering hierarchy in wireless sensor networks,” *J. Sensors*, vol. 2015, 2015, doi: 10.1155/2015/715740.
- [158] X. Yuan, M. Elhoseny, H. K. El-Minir, and A. M. Riad, “A Genetic Algorithm-Based, Dynamic Clustering Method Towards Improved WSN Longevity,” *J. Netw. Syst. Manag.*, vol. 25, no. 1, pp. 21–46, 2017, doi: 10.1007/s10922-016-9379-7.
- [159] Roopali and R. Kumar, “Energy Efficient Dynamic Cluster Head and Routing Path Selection Strategy for WBANs,” *Wirel. Pers. Commun.*, vol. 113, no. 1, pp. 33–58, 2020, doi: 10.1007/s11277-020-07177-6.
- [160] J. Jia, J. Chen, G. Chang, and Z. Tan, “Energy efficient coverage control in wireless sensor networks based on multi-objective genetic algorithm,” *Comput. Math. with Appl.*, vol. 57, no. 11–12, pp. 1756–1766, 2009, doi: 10.1016/j.camwa.2008.10.036.
- [161] S. Hussain, A. W. Matin, and O. Islam, “Genetic Algorithm for Hierarchical Wireless Sensor Networks,” *J. Networks*, vol. 2, no. 5, Sep. 2007, doi: 10.4304/jnw.2.5.87-97.
- [162] X.-S. S. Yang and M. Karamanoglu, *Nature-Inspired Metaheuristic Algorithms Second Edition*, vol. 4, no. C, 2013.
- [163] P. Lalwani, I. Ganguli, and H. Banka, “FARW: Firefly algorithm for Routing in wireless sensor networks,” *2016 3rd Int. Conf. Recent Adv. Inf. Technol. RAIT 2016*, pp. 248–252, 2016, doi: 10.1109/RAIT.2016.7507910.
- [164] M. Singh Manshahia and M. S. Manshahia, “A Firefly Based Energy Efficient Routing in Wireless Sensor Networks,” *African J. Comput. ICT African J. Comput. ICT Ref. Format M.S. Manshahia*, vol. 8, no. 4, pp. 27–32, 2015, [Online]. Available: www.ajocict.net.
- [165] G. Yogarajan and T. Revathi, “Nature inspired discrete firefly algorithm for optimal mobile data gathering in wireless sensor networks,” *Wirel. Networks*, vol. 24, no. 8,
-

-
- pp. 2993–3007, 2018, doi: 10.1007/s11276-017-1517-y.
- [166] K. James, E. Russell, C., and S. Yuhui, *Swarm Intelligence Team LRN_ BOOK*. 2001.
- [167] E. Bonabeau, “Eric Bonabeau,” *Complex. 5 Quest.*, no. August 2014, pp. 21–26, 2008.
- [168] Z. Albayrak and A. Zengin, “Bee-MANET: A new swarm-based routing protocol for wireless ad hoc networks,” *Elektron. ir Elektrotehnika*, vol. 20, no. 3, pp. 91–97, 2014, doi: 10.5755/j01.eee.20.3.3421.
- [169] M. Dorigo, M. Birattari, and T. Stutzle, “Ant colony optimization,” *IEEE Comput. Intell. Mag.*, vol. 1, no. 4, pp. 28–39, Nov. 2006, doi: 10.1109/MCI.2006.329691.
- [170] F. VANDENBERGH and A. ENGELBRECHT, “A study of particle swarm optimization particle trajectories,” *Inf. Sci. (Ny)*, vol. 176, no. 8, pp. 937–971, Apr. 2006, doi: 10.1016/j.ins.2005.02.003.
- [171] X. Liu, “Routing Protocols Based on Ant Colony Optimization in Wireless Sensor Networks: A Survey,” *IEEE Access*, vol. 5, pp. 26303–26317, 2017, doi: 10.1109/ACCESS.2017.2769663.
- [172] T. Camilo, C. Carreto, J. S. Silva, and F. Boavida, “An Energy-Efficient Ant-Based Routing Algorithm for Wireless Sensor Networks,” pp. 49–59, 2006
- [173] W. Cai, X. Jin, Y. Zhang, K. Chen, and R. Wang, “ACO based QoS routing algorithm for wireless sensor networks,” *Lect. Notes Comput. Sci. (including Subser. Lect. Notes Artif. Intell. Lect. Notes Bioinformatics)*, vol. 4159 LNCS, pp. 419–428, 2006, doi: 10.1007/11833529_43.
- [174] D. Cheng, Y. Xun, T. Zhou, and W. Li, “An Energy Aware Ant Colony Algorithm for the Routing of Wireless Sensor Networks,” *Commun. Comput. Inf. Sci.*, vol. 134, no. PART 1, pp. 395–401, 2011, doi: 10.1007/978-3-642-18129-0_62.
- [175] S. Mondal, S. Ghosh, and P. Dutta, “Energy efficient data gathering in wireless sensor networks using rough fuzzy C-means and ACO,” *Lect. Notes Networks Syst.*, vol. 11, no. July, pp. 163–172, 2018, doi: 10.1007/978-981-10-3953-9_16.
- [176] J. C. Bezdek, R. Ehrlich, and W. Full, “FCM: The fuzzy c-means clustering algorithm,” *Comput. Geosci.*, vol. 10, no. 2–3, pp. 191–203, Jan. 1984, doi: 10.1016/0098-3004(84)90020-7.
- [177] L. A. Zadeh, “Fuzzy logic = computing with words,” in *IEEE Transactions on Fuzzy Systems*, vol. 4, no. 2, pp. 103–111, May 1996, doi: 10.1109/91.493904.
- [178] M. Hadjila, H. Guyennet, and M. Feham, “A hybrid cluster and chain-based routing
-

-
- protocol for lifetime improvement in WSN,” *Lect. Notes Comput. Sci. (including Subser. Lect. Notes Artif. Intell. Lect. Notes Bioinformatics)*, vol. 8458, pp. 257–268, 2014, doi: 10.1007/978-3-319-13174-0_20.
- [179] G. Dhand and S. S. Tyagi, “SMEER: Secure Multi-tier Energy Efficient Routing Protocol for Hierarchical Wireless Sensor Networks,” *Wirel. Pers. Commun.*, vol. 105, no. 1, pp. 17–35, 2019, doi: 10.1007/s11277-018-6101-y.
- [180] R. Eberhart and J. Kennedy, “New optimizer using particle swarm theory,” *Proc. Int. Symp. Micro Mach. Hum. Sci.*, pp. 39–43, 1995, doi: 10.1109/mhs.1995.494215.
- [181] R. S. Y. Elhabyan and M. C. E. Yagoub, “Two-tier particle swarm optimization protocol for clustering and routing in wireless sensor network,” *J. Netw. Comput. Appl.*, vol. 52, pp. 116–128, 2015, doi: 10.1016/j.jnca.2015.02.004.
- [182] N. Bilandi, H. K. Verma, and R. Dhir, “PSOBAN: a novel particle swarm optimization based protocol for wireless body area networks,” *SN Appl. Sci.*, vol. 1, no. 11, pp. 1–14, 2019, doi: 10.1007/s42452-019-1514-0.
- [183] R. A. Isabel and E. Baburaj, “An Optimal Trust Aware Cluster Based Routing Protocol Using Fuzzy Based Trust Inference Model and Improved Evolutionary Particle Swarm Optimization in WBANs,” *Wirel. Pers. Commun.*, vol. 101, no. 1, pp. 201–222, 2018, doi: 10.1007/s11277-018-5683-8.
- [184] P. Kuila and P. K. Jana, “Energy efficient clustering and routing algorithms for wireless sensor networks: Particle swarm optimization approach,” *Eng. Appl. Artif. Intell.*, vol. 33, pp. 127–140, 2014, doi: 10.1016/j.engappai.2014.04.009.
- [185] G. Saranraj and K. Selvamani, “Particle with Ant Swarm Optimization for Cluster Head Selection for Wireless Sensor Networks,” *J. Comput. Theor. Nanosci.*, vol. 14, no. 6, pp. 2910–2914, Jun. 2017, doi: 10.1166/jctn.2017.6593.
- [186] J. Wang, Y. Cao, B. Li, H. jin Kim, and S. Lee, “Particle swarm optimization based clustering algorithm with mobile sink for WSNs,” *Futur. Gener. Comput. Syst.*, vol. 76, pp. 452–457, 2017, doi: 10.1016/j.future.2016.08.004.
- [187] S. Sarangi, “A Novel Routing Algorithm for Wireless Sensor Network Using Particle Swarm Optimization,” *IOSR J. Comput. Eng.*, vol. 4, no. 1, pp. 26–30, 2012, doi: 10.9790/0661-0412630.
- [188] P. Nayak and C. P. Reddy, “Bio-inspired routing protocol for wireless sensor network to minimise the energy consumption,” *IET Wirel. Sens. Syst.*, vol. 10, no. 5, pp. 214–220, 2020, doi: 10.1049/iet-wss.2019.0198.
- [189] S. Mirjalili, S. M. Mirjalili, and A. Lewis, “Grey Wolf Optimizer,” *Adv. Eng. Softw.*,
-

-
- vol. 69, pp. 46–61, 2014, doi: 10.1016/j.advengsoft.2013.12.007.
- [190] A. Lipare, D. R. Edla, and V. Kuppili, “Energy efficient load balancing approach for avoiding energy hole problem in WSN using Grey Wolf Optimizer with novel fitness function,” *Appl. Soft Comput. J.*, vol. 84, p. 105706, 2019, doi: 10.1016/j.asoc.2019.105706.
- [191] X. Yang and Suash Deb, "Cuckoo Search via Lévy flights," *2009 World Congress on Nature & Biologically Inspired Computing (NaBIC)*, 2009, pp. 210-214, doi: 10.1109/NABIC.2009.5393690.
- [192] M. Khabiri and A. Ghaffari, “Energy-Aware Clustering-Based Routing in Wireless Sensor Networks Using Cuckoo Optimization Algorithm,” *Wirel. Pers. Commun.*, vol. 98, no. 3, pp. 2473–2495, 2018, doi: 10.1007/s11277-017-4983-8.
- [193] A. Zengin, “BeeWS : Honeybee-inspired , large-scale routing protocol for wireless sensor networks (WSNs) BeeWS : honeybee-inspired , large-scale routing protocol for wireless sensor networks (WSNs) Fatih Çelik * and Ahmet Zengin,” vol. 27, no. September, pp. 58–68, 2018.
- [194] K. M. Passino, “Biomimicry of Bacterial Foraging for Distributed Optimization and Control,” *IEEE Control Syst.*, vol. 22, no. 3, pp. 52–67, 2002, doi: 10.1109/MCS.2002.1004010.
- [195] P. Lalwani and S. Das, “Bacterial Foraging Optimization Algorithm for CH selection and routing in wireless sensor networks,” *2016 3rd Int. Conf. Recent Adv. Inf. Technol. RAIT 2016*, pp. 95–100, 2016, doi: 10.1109/RAIT.2016.7507882.
- [196] P. Rana and K. Sharma, “Energy Efficient grid based routing algorithm using closeness centrality and BFO for WSN,” *Int. Res. J. Eng. Technol.*, vol. 4, no. 7, 2017, [Online]. Available: <https://irjet.net/archives/V4/i7/IRJET-V4I7336.pdf>.
- [197] Khan BM, Bilal R (2018) Fuzzy-Topsis-based cluster head selection in Mobile wireless sensor networks, *Adv Wireless Technol Telecom*, 312-343
- [198] E. Bulut and O. Duru, *Analytic Hierarchy Process (AHP) in Maritime Logistics: Theory, Application and Fuzzy Set Integration*, vol. 260, no. March 2021. 2018.
- [199] G. Dhiman and V. Kumar, “Emperor penguin optimizer: A bio-inspired algorithm for engineering problems,” *Knowledge-Based Syst.*, vol. 159, pp. 20–50, 2018, doi: 10.1016/j.knosys.2018.06.001.
- [200] S. Shadravan, H. R. Naji, and V. K. Bardsiri, “The Sailfish Optimizer: A novel nature-inspired metaheuristic algorithm for solving constrained engineering optimization problems,” *Eng. Appl. Artif. Intell.*, vol. 80, no. January, pp. 20–34,
-

2019, doi: 10.1016/j.engappai.2019.01.001.

[201] Huang H, Zhang J, Zhang X, Yi B, Fan Q, Li F (2017) Emgr: Energy efficient multicast geographic routing in wireless sensor networks. *Comput Netw* 129:51–63

List of Publications

Refereed Journal Publication (SCI/SCIE)

1. **Mehta, D.**, Saxena, S, "MCH-EOR: Multi-objective Cluster Head Based Energy-aware Optimized Routing algorithm in Wireless Sensor Networks," *Sustain. Comput. Informatics Syst.*, vol. 28, p. 100406, Dec. 2020, doi: 10.1016/j.suscom.2020.100406.
2. **Mehta, D.**, Saxena, S. Hierarchical WSN protocol with fuzzy multi-criteria clustering and bio-inspired energy-efficient routing (FMCB-ER). *Multimed Tools Appl* (2020). <https://doi.org/10.1007/s11042-020-09633-8>
3. **Mehta, D.**, Saxena, S. Load-based node ranked low-energy adaptive clustering hierarchy: An enhanced energy-efficient algorithm for cluster head selection in wireless sensor networks. *Concurrency Computat Pract Exper.* 2021; 33:e6416. <https://doi.org/10.1002/cpe.6416>

Conference Publications (IEEE)

1. **Deepak Mehta** and Sharad Saxena, "A Comparative Analysis of Energy Efficient Hierarchical Routing Protocols for Wireless Sensor Networks," 2018 **4th International Conference on Computing Sciences (ICCS)**, Jalandhar, 2018, pp. 53-58, doi: 10.1109/ICCS.2018.00015.
2. **Deepak Mehta** and Sharad Saxena, "Swarm Intelligence based Hierarchical Routing Protocols Study in WSNs," 2020 **Sixth International Conference on Parallel, Distributed and Grid Computing (PDGC)**, Wagnaghat, Solan, India, 2020, pp. 272-277, doi: 10.1109/PDGC50313.2020.9315750.