

RELIABILITY AND AVAILABILITY ANALYSIS OF TIMBER PROCESSING PLANT

**Thesis submitted in partial fulfillment of the requirement for
The award of the degree of**

**Masters of Science
In
Mathematics and Computing**

***Submitted by*
Hitesh Sood
Roll no. - 300903006**



**Under the guidance of
Dr. A. K. Lal**

**School of Mathematics and Computer Applications
Thapar University
Patiala-147004 (PUNJAB)
INDIA**

JULY 2012

CERTIFICATE

I hereby certify that the work which is being presented in the thesis entitled "**Reliability And Availability Analysis of Timber Processing Plant**" in partial fulfillment of the requirements for the award of degree of Master of Science, School of Mathematics and Computer Applications, Thapar University, Patiala is an authentic record of my own work carried out under the supervision of Dr.A.K.Lal.

The matter presented in this thesis has not been submitted for the award of any other degree of this or any other university.



(Hitesh Sood)

This is to certify that the above statement made by the candidate is correct and true to the best of my knowledge.



Dr. A. K. Lal
Associate Professor
SMCA, Thapar University
Patiala

Countersigned by:

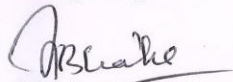

Dr. S.S. Bhatia
(Professor & Head)
School of Mathematics & Computer Applications
Thapar University, Patiala.



Dr. S.K. Mohapatra
Dean of Academic Affairs
Thapar University

ACKNOWLEDGEMENT

It gives me immense pleasure to acknowledge my sincere gratitude to my academic supervisor, Dr. A.K.Lal, School of Mathematics and Computer Applications, Thapar University, Patiala, for his constant help, encouragement and support throughout the course of this work.

I would like to extend my special thanks to Dr. S. S. Bhatia, Prof and Head, School of Mathematics and Computer Applications, Thapar University, Patiala, providing help and necessary facilities in the department and directly or indirectly encouraged me to work harder during the whole course.

I would like to thank my parents for their unconditional support and encouragement and my friends who helped me a lot when I was in difficulties.

I am also very much thankful to my brothers who contributed a lot in accomplishing this piece of work to be a successful one

Dated:

(Hitesh Sood)

ABSTRACT

We generally use the word reliable in our daily life. To study and analyze the performance of any product, a time based quality concept has been evolved which is called reliability. Everyone thinks of reliability of any product before purchasing that product. Today, reliability is one of the most important quality characteristics for customers and is used for products, systems, processes and components of system.

First chapter is introductory in nature. In this chapter, we have briefly given introduction to reliability. Definition of reliability and basic concepts are discussed. A brief summary of literature available on the subject and summary of the work presented in the thesis also appears in this chapter.

In the second chapter, the reliability of timber processing plant has been analyzed. The plant consists of seven sub-systems, namely Length cutting of long timber logs, Supply of timber logs to Horizontal Band Saw through Crane, Horizontal Band Saw which cuts huge timber log into small portions dimensionally suitable for cutting on Vertical Band Saw, Vertical Band Saw where timber pieces supplied from Horizontal Band Saw are to be cut into exact sizes along breadth and height wise, Sizzling Chamber in which timber is dried, Planner through which timber is smoothed and Final Inspection. Sizzling Chamber can also work in reduced state. The mathematical formulation of the problem is carried out using Markov-method. The Chapman-Kolomorgov differential equations are solved by using Runge-Kutta fourth order method to find out the reliability. The effect of failure and repair rates on the reliability has been studied in detail with the help of graphs and tables.

In third chapter, we have given brief introduction to timber processing plant and also discuss the availability of timber processing plant. Industrial significance of the present work as well as the limitations and future scope of the work are also briefly discussed in this section.

SYMBOLS USED IN THESIS

SYMBOLS	DESCRIPTION
α_i	Failure rates of the sub-systems
β_i	Repair rates of the sub-systems
MTBF	Mean time before failure
R (t)	Reliability at time t
X	Represents that the sub-system X is in good state
\bar{X}	Represents that the sub-system X is in reduced state
x	Represents that the sub-system X is in failed state
t	Total test time

CONTENTS

Certificate

Acknowledgement

Abstract

Symbols Used

CHAPTER	DESCRIPTION	PAGE No.
1	INTRODUCTION	(1-6)
	1.1 Introduction to Reliability	
	1.2 Definition and Basic Concepts	
	1.3 Literature Review	
	1.4 Summary of the Present Work	
2	RELIABILITY ANALYSIS OF TIMBER PROCESSING PLANT	
(7-26)		
	2.1 System and Notations	
	2.2 Assumptions	
	2.3 Mathematical Formulation	
	2.4 Behavior Study	
	2.5 Analysis of Results	
3	AVAILABILITY ANALYSIS OF TIMBER PROCESSING	
PLANT (27-29)		
	3.1 mathematical formulation for availability Analysis of Timber Processing Plant	
	3.2 Industrial Significance of this Study	
	3.3 Limitations and Future Scope of the Present Study	
	REFERENCES	(
30- 31)		

CHAPTER 1

INTRODUCTION

We all have some notion of the word reliability. Everyone is interested in the reliability of a product before purchasing it. When we say that a particular product manufactured by a particular firm is reliable, we mean that its performance is trouble-free, but we do not completely ignore the possibility of failure. However based on the quality of components used in manufacturing of that product we conclude that the chances of its failure are very few. We shall define reliability as follows: The probability that an item can perform its intended function for a specified interval under stated conditions.

This definition states that reliability is the probability of a device giving satisfactory performance for a specified period under specified operating conditions.

The reliability of engineering systems has become an important factor during their planning, design and operation. The factors that are responsible for this include increasing complexity of modern engineering systems, the quality of material used in their manufacture, the conditions or environment in which they operate and so on. Reliability analysis is an analytical problem that deals with statistical and engineering aspects of the problem. It must be given critical attention throughout the life of a system including its development, design, production, quality control, shipping, installation, operation and maintenance. In the present work we have chosen timber processing plant for analyzing its reliability and availability. This chapter is organized as follows: section 1.1 deals with the basic concepts and definitions required to study the reliability and availability of the system. Literature survey available on this subject next discussed in section 1.2. In section 1.3 the summary of the present work is finally presented.

1.1 DEFINITION AND BASIC CONCEPTS

Reliability is the probability of device performing its purpose adequately for the period intended under the given operating conditions.

This definition brings into focus four important factors, namely,

- (a) The reliability of a device is expressed as a probability
- (b) The device is required to give sufficient performance
- (c) The duration of sufficient performance is specified
- (d) The environmental or operating conditions are prescribed.

These four factors are very important in the determination of reliability. We shall briefly discuss each one of these.

Reliability expressed as probability. Probability is the ratio of the number of times an event is expected to occur to the total number of trials undertaken. This ratio lies between 0 and 1. If reliability is 1 it means that the device performs satisfactorily for the prescribed duration under the given environmental conditions and if reliability is zero it means that in almost all cases the equipment would fail to achieve the desired performance level. It is necessary to keep in mind that reliability factor of one would not mean that there is a guarantee that every unit of the device which is used will perform satisfactorily. It is possible that out of 100 trials, 1 or 2 units may fail, but the ratio of the number of failures to the number of success is expected to approach zero as the number of trials increases.

Sufficient performance is the second element in the definition of reliability. It describes in unambiguous terms, what is expected of a device or system. There may be instances, however, of a system giving satisfactorily performance even when one or two of its components may not be functioning. As an example, consider the spark-plugs of an eight-cylinder automobile. If one plug is not functioning properly, the automobile may still reach its destination in the prescribed time and thus meet the requirement of satisfactorily performance. On the other hand, its performance would be unsatisfactory there were a complete breakdown of the engine. Hence, a definite criterion must be established to clearly describe that what is considered to be satisfactorily performance.

Duration of sufficient performance is one of the most important elements in the definition since it represents a measure of the period for which the performance is satisfactory. Most units or systems fail when operated over long periods. Deterioration of materials and parts is natural and consequently the performance level of the unit will also go down with time. Therefore, it is necessary to specify a time limit within which the performance of a unit is to be assessed as being satisfactory or unsatisfactory.

Operating conditions

The environmental or operating conditions such as temperature, humidity, shock, vibration and so on should be specified in which we expect a device to function sufficiently. For example, an air conditioner which performs satisfactorily in temperature zone may not have the same characteristics for hot and arid climate conditions.

Failure Rate

This is the ratio of the number of failures of the items undergoing test to the test time. Failure rate is expressed in terms of number of failures per unit time, for example, failures per hour or failures per day or failures per year. Failure rate is also known as the hazard rate. Sometimes, it is called the instantaneous failure rate.

Repair Rate: This is the ratio of the number of repairs of the items undergoing test to the test time. Repair rate is expressed in terms of number of repairs per unit time, for example, repairs per hour or repairs per day or repairs per year. Sometimes, it is called the instantaneous repair rate.

Mean Time before Failures: Mean time before failures, *MTBF* is the statistical average time before failure of the systems. When failure rate is fairly constant, then *MTBF* is defined as

$$MTBF = \int_0^{\infty} R(t) dt$$

Series Systems: In a series system the components are connected in such away that if any one of the components fails the entire system fails.

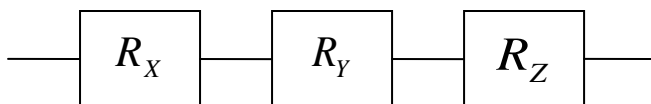

R_X denotes the reliability of component X.

R_Y denotes the reliability of component Y.

R_Z denotes the reliability of component Z.

Assuming that the components are independent, the reliability of the system is given by

$$R_{system} = (R_X).(R_Y).(R_Z)$$

1.2 LITERATURE REVIEW

Realizing the importance of the subject, reliability theory has been developed and a number of authors have been given a good contribution. The first textbook on reliability by Dummer and Griffen (5) appeared in literature. Barlow and Hunter (8) analyzed the reliability of a one-unit system. In India professor R.S. Verma and his students Garg, Mohan and Singla (3) at Delhi University initiated the study of reliability technology. Hosford (9) considered a one unit system with two states, namely, operating and failed, failure and repair being both of stationary type and found the probabilities of the system being in either state at an instant of time. Mohan and Garg (3) considered a two unit system with general failure and exponential repair time distributions and solved the problem using the supplementary variable technique verifying the result of Hosford (9) as special case. An extensive bibliography for these methods was given by Barlow, Hunter and Proschan (11). Linton and Saw(4) considered reliability analysis of the (k, n) system. Kapoor and Kapoor (16) discussed the effect of standby redundancy on system reliability. Singh (2) considered a similar system with imperfect switchover device. Arrarwal and Kumar (21) considered a review of standby system. Kumar et al. (11) and Singh et al. (17) considered reliability of some complex industrial systems. Complexity also occurs in automobile systems. Such systems have been discussed by William (7) and Dhilon et al. (20). The earlier researchers in the field of reliability analyzed the system using Laplace transform. Most of these workers discussed the systems exhibiting Markovian properties. The systems having non-Markovian property can be converted to a system having markovian nature using some techniques, introducing some new variables called supplementary variables, Cox (1) analyzed the non-Markovian systems using supplementary variables.

Fredrick and Hunziker (16) have given details of butter industry. Lambert (10) has considered the overview of small-scale milk collections and processing plant. Habchi (6) discussed an improved method of reliability assessment for suspended tests and Gunes and Deveci (19) have studied the reliability of service systems and its application in student office. When a system consists of more than one unit there is a possibility for complete failure of the system due to single cause. Such failures are termed as common cause failures and these are highly effective as far as reliability

analysis of the system is considered. Gagloft (12) defined the common cause failure in a system when multiple units or components at any instant fail due to single common cause. Flemming (16) and Dhilon (15) analyzed the problem of system reliability with identical units having statistically independent and dependent (common cause) failures. Cate et al. (18) extended this idea to complex systems and developed a computer-based approach. Dhilon and Misra (13) introduced the important factor of critical human error, which causes complete failure of the system. Dhilon (14) provided extensive bibliography for human reliability. Chung (17) extended the idea to a repairable system, which is subject to failures due to common cause and critical human errors. Such systems are very common in our daily life. Pawan Gupta (21) has discussed Mathematical analysis of reliability and availability of some process industries. Recently Lata (24) used this methodology to study reliability of Piston manufacturing plant.

In the present work, problem of timber process industry has been formulated with the help of Markovian method. The Chapman-Kolomorgov differential equations determining the reliability of the process industries have been solved numerically using Runge-Kutta fourth order method. The reliability of the process industries has been calculated with the help of these methods for the various combinations of failure and repair rates of the subsystems.

1.3 SUMMARY OF THE PRESENT WORK

In the present work, we have discussed the reliability and availability of Bharat Saw Mills a timber processing plant situated in Sirhind. We are assuming constant repair and failure rates of their sub-systems. We are using actual case studies of the Sirhind Plant for Reliability and availability analysis of timber processing manufacturing plant. The plant consists of seven sub-systems, namely Length cutting of long timber logs, Supply of timber logs to Horizontal Band Saw through Crane, Horizontal Band Saw which cuts huge timber log into small portions dimensionally suitable for cutting on Vertical Band Saw, Vertical Band Saw where timber pieces supplied from Horizontal Band Saw are to be cut into exact sizes along breadth and height wise, Sizzling Chamber in which timber is dried, Planner through which timber is smoothed and Final Inspection. Sizzling Chamber can also work in reduced state. Markov-method is used for mathematical formulation. In order to find the reliability

the Chapman-Kolomorogov differential equations are solved using Runge-Kutta fourth order method. The effect of failure rates and repair rates on the reliability of the system has been studied in detail with actual data taken from the concerned industries.

RELIABILITY ANALYSIS OF TIMBER PROCESSING PLANT

This chapter is organized as follows: The system and their notation are discussed in section 2.1. this section also exhibits the flow chart for timber processing plant as well as certain assumptions on which the present analysis based on. In section 2.2 we have developed mathematical model of determining reliability of process industry. The behavioural analysis of the system is carried out in section 2.3. In section 2.4, we have finally discussed concluding observations of our result.

2.1 SYSTEM, NOTATIONS AND ASSUMPTIONS

After noting the sizes of timber required the huge timber log of weight nearly equal to 10 ton is selected through the lot of logs of various lengths and then the machining operations on the Log is started to make it complete product, it consists of following seven sub-systems:

1. Sub-system *A* (Log length cutter): In this process the selected log is cut into the logs of smaller lengths (still weighing 3 to 4 ton) by two man saw electric cutter into the desired length so that the length of log is suitable for cutting on Horizontal Band Saw. The sub-system is subject to major failure.
2. Sub-system *B* (Transportation of log by Crane): In this process the selected round log is transported to the Horizontal Band Saw machine with the help of a crane of capacity minimum 10 Ton. The sub-system is subject to major failure.
3. Sub-system *C* (Horizontal Band Saw): On this machine the selected piece of log is cut down along diameter in to light pieces (still weighing .01 ton to .05 ton) so that now further processed on Vertical Band Saw. It consists of a blade belt and an electric motor of 20 hp. The sub-system is subject to major failure.
4. Sub-system *D* (Vertical Band Saw): On this machine the timber pieces already cut on Horizontal Band Saw are cut to actual desirable sizes along the length and breadth wise. . It consists of a blade belt and an electric motor of 12 hp. The sub-system is subject to major failure.
5. Sub-system *E* (Sizzling Chamber): It is used to dry the timber pieces. It consists of three fans, four motors and one hydraulic pump (to increase the temperature). If any one motor fails the system goes in reduced state and system fails if more than one motor fails The sub-system is subject to major and minor failure.

6. Sub-system *F* (Planner): It is used to dazzle the small pieces. It consists of four blades, one roller and one electric motor of 2 hp. The sub-system is subject to major failure only.

7 Sub-system *G* (Final Inspection): After the planner treatment the Final corners of the piston so that it can run smoothly in the cylinder. The sub-system is subject to major failure. This type of Inspection is very essential to insure that no faulty product is dispatched to the customer, which otherwise will bring down to reputation, goodwill & hence the market share of processingplant.

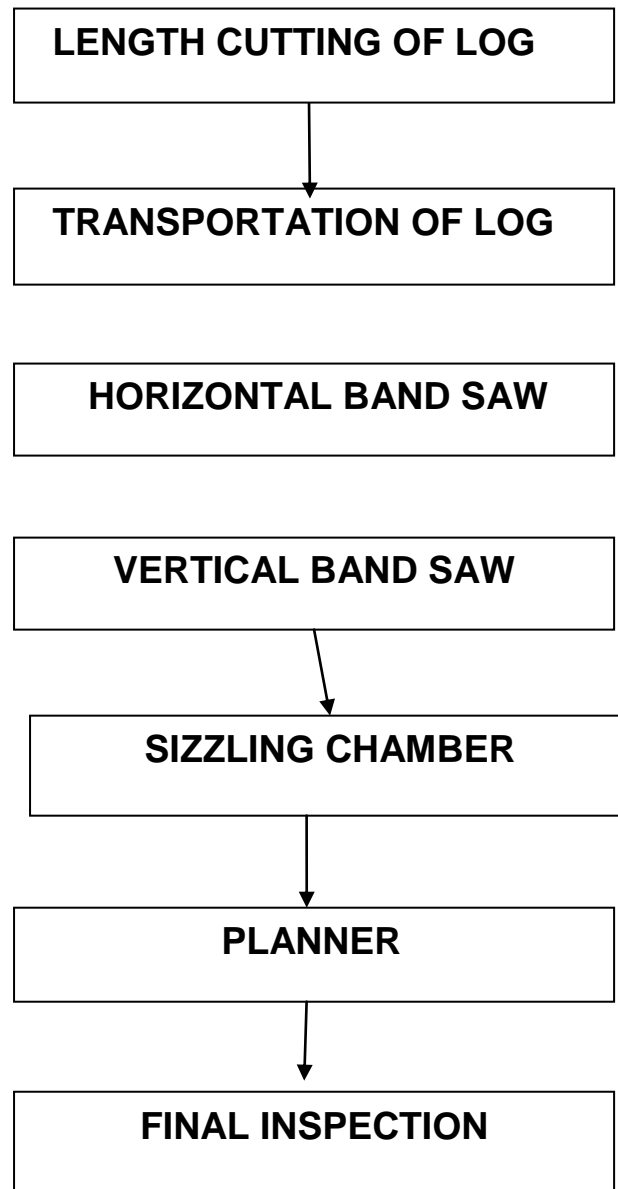

FIGURE 2.1: Flow chart of timber processing plant

NOTATIONS: We are using the following notations for system

A, B, C, D, E, F and G denotes good conditions of the systems. \bar{E} indicate that sub-systems E is working in reduced states.

α_i (i=1 to 7) represents respective constant failure rates of sub-systems $A, B, C, D, \bar{E}, F, G$.

β_i (i=1 to 7) represents respective constant repair rates of sub-systems $A, B, C, D, \bar{E}, F, G$.

$P_j(t)$ = Probability that system is in j^{th} state at time t, (j=1, 2, 3, ..., 15).

Small letters a, b, c, d, e, f and g indicate the failed states of the sub-systems A, B, C, D, E, F and G respectively.

ASSUMPTIONS FOR THE SUB-SYSTEM R1

- (i) Failure and repair rates are independent with each other and their unit is per hour.
- (ii) There are no simultaneous failures among the sub-systems.
- (iii) Sub-systems C and E fail only through reduced states.
- (iv) Repair of C and E in reduced state does not make these sub-systems completely functional.
- (v) Switching to stand by components is perfect.

Following the above notations and assumptions the transition diagram of the system is given in Figure 2.2.

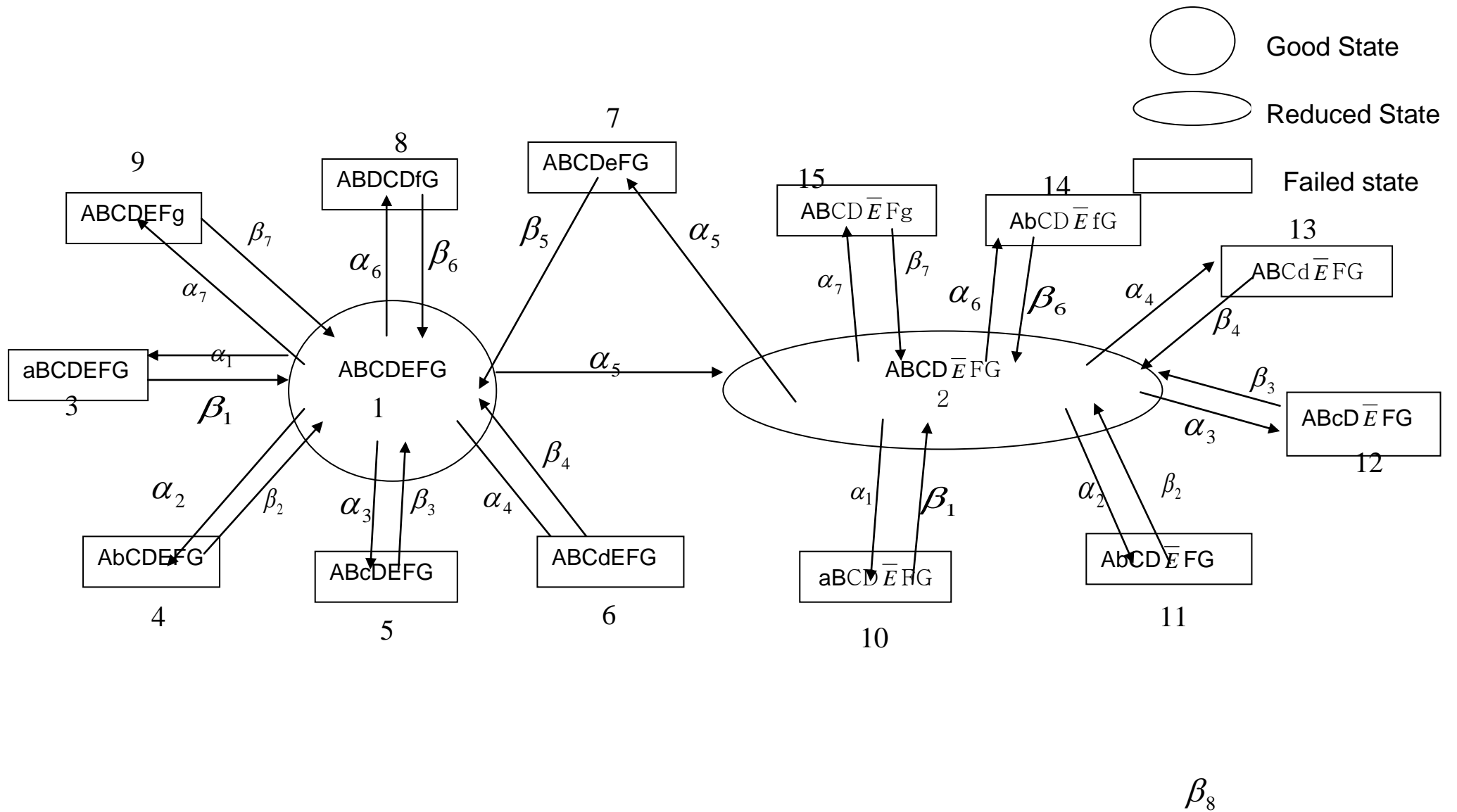

FIGURE 2.2 Transition diagram for sub-system R1

2.2 RELIABILITY MODEL OF THE PROCESS INDUSTRY

In the transient state, probability considerations give the following first order differential equations associated with the transition diagram of the system.

$$\begin{aligned}
 P_1'(t) + \lambda_1 P_1(t) &= \beta_1 P_3(t) + \beta_2 P_4(t) + \beta_3 P_5(t) + \beta_4 P_6(t) + \beta_5 P_7(t) + \beta_6 P_8(t) + \beta_7 P_9(t) \\
 P_2'(t) + \lambda_2 P_2(t) &= \beta_1 P_{10}(t) + \beta_2 P_{11}(t) + \beta_3 P_{12}(t) + \beta_4 P_{13}(t) + \beta_6 P_{14}(t) + \beta_7 P_{15}(t) + \alpha_5 P_1(t) \\
 P_3'(t) + \beta_1 P_3(t) &= \alpha_1 P_1(t) \\
 P_4'(t) + \beta_2 P_4(t) &= \alpha_2 P_1(t) \\
 P_5'(t) + \beta_3 P_5(t) &= \alpha_3 P_1(t) \\
 P_6'(t) + \beta_4 P_6(t) &= \alpha_4 P_1(t) \\
 P_7'(t) + \beta_5 P_7(t) &= \alpha_5 P_2(t) \\
 P_8'(t) + \beta_6 P_8(t) &= \alpha_6 P_1(t) \\
 P_9'(t) + \beta_7 P_9(t) &= \alpha_7 P_1(t) \\
 P_{10}'(t) + \beta_1 P_{10}(t) &= \alpha_1 P_2(t) \\
 P_{11}'(t) + \beta_2 P_{11}(t) &= \alpha_2 P_2(t) \\
 P_{12}'(t) + \beta_2 P_{12}(t) &= \alpha_3 P_2(t) \\
 P_{13}'(t) + \beta_4 P_{13}(t) &= \alpha_4 P_2(t) \\
 P_{14}'(t) + \beta_6 P_{14}(t) &= \alpha_6 P_2(t) \\
 P_{15}'(t) + \beta_7 P_{15}(t) &= \alpha_7 P_2(t)
 \end{aligned} \tag{2.1}$$

Where,

$$\lambda_1 = \alpha_1 + \alpha_2 + \alpha_3 + \alpha_4 + \alpha_5 + \alpha_6 + \alpha_7$$

$$\lambda_2 = \alpha_1 + \alpha_2 + \alpha_3 + \alpha_4 + \alpha_5 + \alpha_6 + \alpha_7$$

$$\text{with initial conditions } P_1(0)=1 \text{ and } 0, \text{ otherwise.} \tag{2.2}$$

Following the approach of Gupta et-at (22)

The above equations have been solved numerically using Runge-Kutta Fourth Order Method. The numerical integration is performed with $t=0.005$ assuming as one day, therefore to get the reliability upto 360 days we will have to perform 72000 iterations with the Runge-Kutta Fourth Order Method. The reliability function $R(t)$ of the system is computed by

$$R(t) = \sum_{i=1}^2 P_i(t) \quad (2.3)$$

The Reliability of the system, as defined above has been computed for various values of the failure rates and repair rates.

2.3 BEHAVIOUR STUDY

The system of above differential equations with initial conditions has been solved numerically using Runge-Kutta Fourth Order Method. The computations have been performed upto 360 days for various values of failure and repair rates of the sub-systems, by taking the data for failure rates and repair rates of the sub-systems per hour. The effect of various parameters on reliability of system is studied in this section. If the failure and repair rates are altered, the reliability is affected.

(i) Effect of failure rate of log length cutter on reliability of the system:

The reliability of the system is computed by using the following combinations of failure and repair rates. Reliability is presented in Table 2.1(a) The parameter α_1 is considered at the level of 0.00274, 0.00548, 0.01096, 0.02192, 0.03288 and other parameters are taken as: $\alpha_2=0.01096$, $\alpha_3=0.01644$, $\alpha_4=0.00548$, $\alpha_5=0.0274$, $\alpha_6=0.0274$, $\alpha_7=0.04109$, $\beta_1=2.25$, $\beta_2=5$, $\beta_3=6.5$, $\beta_4=4.5$, $\beta_5=1.75$, $\beta_6=2$, $\beta_7=0.75$. The table shows the effect of log length cutting machine (α_1) on the reliability of the system. The reliability of the system decreases by 7.76% approximately with the increase of failure rate log length cutter machine from 0.00274 to 0.03288 and by 0.05% approximately with the increase in time from 30 to 360 days.

TABLE 2.1(a): EFFECT OF FAILURE RATE OF LOG LENGTH CUTTING MACHINING (α_1) ON RELIABILITY OF THE SYSTEM

$\alpha_1 \longrightarrow$ Days \downarrow	.00274	.00548	.01096	0.02192	0.03288
30	0.92958	0.92853	0.92644	0.92227	0.85744
60	0.92949	0.92844	0.92635	0.92219	0.85735
90	0.92942	0.92838	0.92628	0.92212	0.85729
120	0.92936	0.92832	0.92622	0.92206	0.85724
150	0.92931	0.92827	0.92617	0.92201	0.85721
180	0.92927	0.92822	0.92612	0.92197	0.85718
210	0.92923	0.92818	0.92609	0.92193	0.85716
240	0.92918	0.92815	0.92606	0.92189	0.85714
270	0.92917	0.92812	0.92603	0.92187	0.85713
300	0.92915	0.92810	0.92598	0.92185	0.85712
330	0.92913	0.92808	0.92598	0.92183	0.85712
360	0.92911	0.92806	0.92597	0.92181	0.85711

(ii) Effect of failure rate of crane on reliability of the system:

Effect of failure rate of crane on the reliability of the system is studied by varying its values as $\alpha_2 = 0.01096, 0.01643, 0.02192, 0.04109, 0.05479$ and other parameters are taken as: $\alpha_1 = 0.00274, \alpha_3 = 0.01644, \alpha_4 = 0.00548, \alpha_5 = 0.0274, \alpha_6 = 0.02740, \alpha_7 = 0.04109, \beta_1 = 2.25, \beta_2 = 5, \beta_3 = 6.5, \beta_4 = 4.5, \beta_5 = 1.75, \beta_6 = 2.0, \beta_7 = 0.7$. Table 2.1(b) shows the effect of failure rate of crane (α_2) on the reliability of the system. The reliability of the system decreases by approximately 0.75% with the increase of failure rate from 0.01096 to 0.05479 but the reliability decreases by approximately 0.05% with the increase in time from 30 to 360 days.

TABLE 2.1(b): EFFECT OF FAILURE RATE OF CRANE (α_2) ON RELIABILITY OF THE SYSTEM

$\alpha_2 \longrightarrow$	0.01096	0.01643	0.02192	0.04109	0.05479
DAYS \downarrow					
30	0.92958	0.92864	0.92769	0.92440	0.92207
60	0.92949	0.92855	0.92761	0.92432	0.92199
90	0.92942	0.92848	0.92754	0.92425	0.92192
120	0.92936	0.92842	0.92748	0.92419	0.92186
150	0.92931	0.92837	0.92743	0.92414	0.92181
180	0.92927	0.92833	0.92738	0.92410	0.92176
210	0.92923	0.92829	0.92734	0.92406	0.92173
240	0.92918	0.92825	0.92731	0.92403	0.92169
270	0.92917	0.92823	0.92728	0.92400	0.92167
300	0.92915	0.92820	0.92726	0.92397	0.92164
330	0.92913	0.92818	0.92724	0.92395	0.92162
360	0.92911	0.92816	0.92722	0.92394	0.92160

(iii) Effect of failure rates of horizontal band saw on reliability of the system:

Effect of failure rate of horizontal band saw machine on the reliability of the system is studied by varying its values as $\alpha_3 = 0.01644, 0.02192, 0.03288, 0.04110, 0.05479$ and other parameters are taken as: $\alpha_1 = 0.00274, \alpha_2 = 0.01096, \alpha_4 = 0.00548, \alpha_5 = 0.00274, \alpha_6 = 0.02740, \alpha_7 = 0.04109, \beta_1 = 2.25, \beta_2 = 5.0, \beta_3 = 6.5, \beta_4 = 4.5, \beta_5 = 1.75, \beta_6 = 0.20, \beta_7 = 0.75$. The table 2.1(c) shows the effect of failure rate of horizontal band saw machine (α_3) on the reliability of the system. It can be noticed that reliability of the system decreases by approximately 0.55% with the increase of failure rate from 0.01644 to 0.05479 but the reliability decreases by approximately 0.045% with the increase in time from 30 to 360 days.

TABLE 2.1(c)
EFFECT OF FAILURE RATE OF ROUGH PIN HOLE BORING (α_7) ON
RELIABILITY OF THE SYSTEM

$\alpha_3 \longrightarrow$	0.01096	0.01644	0.02192	0.04109	0.05479
DAYS \downarrow					
30	0.92958	0.92885	0.92740	0.92632	0.92451
60	0.92949	0.92732	0.92732	0.92623	0.92443
90	0.92942	0.92725	0.92725	0.92616	0.92436
120	0.92936	0.92719	0.92719	0.92610	0.92430
150	0.92931	0.92714	0.92714	0.92605	0.92425
180	0.92927	0.92709	0.92709	0.92601	0.92420
210	0.92923	0.92705	0.92705	0.92597	0.92417
240	0.92918	0.92702	0.92702	0.92594	0.92413
270	0.92917	0.92699	0.92699	0.92591	0.92411
300	0.92915	0.92697	0.92697	0.92588	0.92408
330	0.92913	0.92695	0.92695	0.92586	0.92406
360	0.92911	0.92693	0.92693	0.92585	0.92404

(iv) Effect of failure rates of vertical band saw on reliability of the system:

We have now calculated the reliability of the system by varying the failure rate of vertical band saw machine from $\alpha_4 = 0.00548$ to $\alpha_4 = 0.02466$ and other parameters are taken as: $\alpha_1 = 0.00274$, $\alpha_2 = 0.01096$, $\alpha_3 = 0.01644$, $\alpha_5 = 0.00274$, $\alpha_6 = 0.02740$, $\alpha_7 = 0.04109$, $\beta_1 = 2.25$, $\beta_2 = 5.0$, $\beta_3 = 6.5$, $\beta_4 = 4.5$, $\beta_5 = 1.75$, $\beta_6 = 2.0$, $\beta_7 = 0.75$. The table shows the effect of failure rate of vertical band saw machine (α_4) on the reliability of the system. The reliability of the system decreases by approximately 0.4% with the increase of failure rate of vertical band saw machine from 0.00548 to 0.02466 and by approximately 0.05% with the increase in time from 30 to 360 days.

TABLE 2.1(d): EFFECT OF FAILURE RATE OF VERTICAL BAND SAW MACHINE (α_4) ON RELIABILITY OF THE SYSTEM

$\alpha_4 \longrightarrow$	0.00548	0.01096	0.001370	0.01918	0.02466
Days \downarrow					
30	0.92958	0.92853	0.92801	0.92696	0.92591
60	0.92949	0.92845	0.92792	0.92688	0.92583
90	0.92942	0.92838	0.92785	0.92681	0.92576
120	0.92936	0.92832	0.92779	0.92675	0.92570
150	0.92931	0.92827	0.92774	0.92669	0.92565
180	0.92927	0.92823	0.92770	0.92665	0.92561
210	0.92923	0.92818	0.92766	0.92661	0.92557
240	0.92918	0.92815	0.92763	0.92658	0.92553
270	0.92917	0.92812	0.92760	0.92655	0.92551
300	0.92915	0.92810	0.92757	0.92653	0.92548
330	0.92913	0.92808	0.92755	0.92651	0.92546
360	0.92911	0.92806	0.92754	0.92649	0.92544

(v) Effect of failure rates of sizzling chamber on reliability of the system:

Effect of failure rate of sizzling chamber on reliability of the system is studied by varying its values as $\alpha_5 = 0.00274, 0.00548, 0.00822, 0.001096, 0.001370$ and other parameters are taken as: $\alpha_1 = 0.00274, \alpha_2 = 0.001096, \alpha_3 = 0.001644, \alpha_4 = 0.00548, \alpha_6 = 0.0274, \alpha_7 = 0.0409, \beta_1 = 2.25, \beta_2 = 5.0, \beta_3 = 6.5, \beta_4 = 4.5, \beta_5 = 1.75, \beta_6 = 2.0, \beta_7 = 0.75$. The table shows the effect of failure rate of sizzling chamber (α_8) on the reliability of the system. The reliability of the system decreases by approximately 0.3% with the above mentioned increase in failure rate of sizzling chamber and the reliability decreases by approximately 0.2% with the increase in time from 30 to 360 days.

TABLE 2.1(e): EFFECT OF FAILURE RATE OF SIZZLING CHAMBER (α_5) ON RELIABILITY OF THE SYSTEM

$\alpha_5 \longrightarrow$	0.00274	0.0548	0.00822	0.01096	0.01370
DAYS \downarrow					
30	0.92958	0.92932	0.92894	0.92845	0.92789
60	0.92949	0.92906	0.92846	0.92778	0.92704
90	0.92942	0.92887	0.92816	0.92741	0.92665
120	0.92936	0.92872	0.92798	0.92721	0.92646
150	0.92931	0.92862	0.92786	0.92710	0.92638
180	0.92927	0.92854	0.92778	0.92705	0.92634
210	0.92923	0.92848	0.92773	0.92701	0.92632
240	0.92918	0.92844	0.92770	0.92700	0.92631
270	0.92917	0.92841	0.92768	0.92699	0.92631
300	0.92915	0.92839	0.92767	0.92698	0.92631
330	0.92913	0.92837	0.92766	0.92698	0.92631
360	0.92911	0.92836	0.92765	0.92698	0.92630

(vi) Effect of failure rate of planner on reliability of the system:

We consider the different parameters as: $\alpha_1 = 0.00274$, $\alpha_2 = 0.01096$, $\alpha_3 = 0.01644$, $\alpha_4 = 0.00548$, $\alpha_5 = 0.0274$, $\alpha_7 = 0.04109$, $\beta_1 = 2.25$, $\beta_2 = 5.0$, $\beta_3 = 6.5$, $\beta_4 = 4.5$, $\beta_5 = 1.75$, $\beta_6 = 2.0$, $\beta_7 = 0.75$. Effect of failure rate of planner on reliability of the system is studied by varying its values as $\alpha_6 = 0.0274, 0.04109, 0.0548, 0.06849, 0.08219$ and the table shows the effect of oil hole drilling (α_6) on the reliability of the system. The reliability of the system decreases by approximately 2.50% with the increase of failure rate but the reliability decreases by approximately 0.05% with the increase in time from 30 to 360 days.

TABLE 2.1(f): EFFECT OF FAILURE RATE OF PLANNER (α_6) ON RELIABILITY OF THE SYSTEM

$\alpha_6 \longrightarrow$	0.02740	0.04109	0.0548	0.06849	0.08219
DAYS \downarrow					
30	0.92958	0.92370	0.91789	0.91216	0.90650
60	0.92949	0.92362	0.91781	0.91208	0.90642
90	0.92942	0.92355	0.91774	0.91202	0.90636
120	0.92936	0.92349	0.91769	0.91196	0.90630
150	0.92931	0.92344	0.91764	0.91190	0.90625
180	0.92927	0.92339	0.91759	0.91187	0.90621
210	0.92923	0.92336	0.91755	0.91183	0.90617
240	0.92918	0.92333	0.91752	0.91180	0.90614
270	0.92917	0.92330	0.91749	0.91177	0.90611
300	0.92915	0.92328	0.91747	0.91175	0.90609
330	0.92913	0.92326	0.91745	0.91173	0.90607
360	0.92911	0.92324	0.91743	0.91171	0.90605

(vii) Effect of repair rate of final inspection (α_7) on reliability of the system:

We again consider the failure and repair rates of different components as: $\alpha_1 = 0.00274$, $\alpha_2 = 0.01096$, $\alpha_3 = 0.01644$, $\alpha_4 = 0.00548$, $\alpha_5 = 0.00274$, $\alpha_6 = 0.0274$, $\beta_1 = 2.25$, $\beta_2 = 5.0$, $\beta_3 = 6.5$, $\beta_4 = 4.5$, $\beta_5 = 1.75$, $\beta_6 = 2.0$, $\beta_7 = 0.75$ with values of $\alpha_7 = 1.08, 1.09, 1.10, 1.11, 1.12$. The table shows that the reliability of the system increases by approximately 6.5% with the increase of the repair rate from 1.08 to 1.12, but decreases by approximately 0.05% with the increases in time from 30 to 360 days.

TABLE 2.1(g): EFFECT OF REPAIR RATE OF FINAL INSPECTION (α_7) ON RELIABILITY OF THE SYSTEM

$\alpha_7 \longrightarrow$	0.4109	0.05479	0.06849	0.08219	0.09589
DAYS \downarrow					
30	0.92958	0.91406	0.89905	0.88453	0.87046
60	0.92949	0.91398	0.89898	0.88445	0.87039
90	0.92942	0.91392	0.89891	0.88439	0.87033
120	0.92936	0.91386	0.89886	0.88434	0.87028
150	0.92931	0.91381	0.89881	0.88429	0.87024
180	0.92927	0.91376	0.89877	0.88425	0.87020
210	0.92923	0.91373	0.89873	0.88422	0.87017
240	0.92918	0.91369	0.89870	0.88419	0.87014
270	0.92917	0.91367	0.89867	0.88416	0.87011
300	0.92915	0.91364	0.89865	0.88414	0.87009
330	0.92913	0.91362	0.89863	0.88412	0.87007
360	0.92911	0.91361	0.89861	0.88410	0.87006

(viii) Effect of repair rate of log length cutter machine (β) on reliability of the system:

The effect of repair rate of log length cutting machine (β_1) on the reliability of the system is studied by varying its values as $\beta_1 = 2.25, 2.0, 1.5, 1.0, 0.5$ and other parameters are taken as: $\alpha_1 = 0.00274, \alpha_2 = 0.01096, \alpha_3 = 0.01644, \alpha_4 = 0.00548, \alpha_5 = 0.00274, \alpha_6 = 0.02740, \alpha_7 = 0.04109, \beta_2 = 5, \beta_3 = 6.5, \beta_4 = 4.5, \beta_5 = 1.75, \beta_6 = 2.00, \beta_7 = 0.75$. The table shows that the reliability increases by approximately 0.4% with the increase in the repair rate of log length cutter machine (β_1) but decreases by approximately 0.05% with the increases in time.

TABLE 2.2(a) : EFFECT OF REPAIR RATE OF LOG LENGTH CUTTING MACHINE (β_1) ON RELIABILITY OF THE SYSTEM

$\beta_2 \longrightarrow$	2.25	2.0	1.5	1.0	0.5
DAYS \downarrow					
30	0.92958	0.92945	0.92906	0.92827	0.92591
60	0.92949	0.92937	0.92897	0.92819	0.92583
90	0.92942	0.92930	0.92890	0.92812	0.92576
120	0.92936	0.92924	0.92884	0.92805	0.92570
150	0.92931	0.92918	0.92879	0.92800	0.92565
180	0.92927	0.92914	0.92875	0.92796	0.92561
210	0.92923	0.92910	0.92871	0.92792	0.92557
240	0.92918	0.92907	0.92867	0.92789	0.92553
270	0.92917	0.92904	0.92865	0.92786	0.92551
300	0.92915	0.92902	0.92862	0.92783	0.92548
330	0.92913	0.92899	0.92860	0.92781	0.92546
360	0.92911	0.92898	0.92858	0.92780	0.92544

(ix) Effect of repair rate of crane (β_2) on reliability of the system :

Effect of repair rate of rough pin hole boring (β_2) on the reliability of the system has now been considered. We have considered values as $\beta_2 = 4.5, 3.5, 2.5, 1.5, 0.5$ and other parameters are taken as: $\alpha_1 = 0.00274, \alpha_2 = 0.001096, \alpha_3 = 0.001644, \alpha_4 = 0.00548, \alpha_5 = 0.0274, \alpha_6 = 0.02740, \alpha_7 = 0.04109, \beta_1 = 2.25, \beta_3 = 0.5, \beta_4 = 4.5, \beta_5 = 1.75, \beta_6 = 2.0, \beta_7 = 0.75$. The table shows that the reliability of the system increases by approximately 0.5% with the increase of the repair rate from 0.059 to 0.063, but decreases by approximately 0.05% with the increases in time from 30 to 360 days.

TABLE 2.2(b): EFFECT OF REPAIR RATE OF CRANE (β_2) ON RELIABILITY OF THE SYSTEM

$\beta_7 \longrightarrow$	4.5	3.5	2.5	1.5	0.5
DAYS \downarrow					
30	0.92958	0.92937	0.92877	0.92769	0.92518
60	0.92949	0.92929	0.92869	0.92761	0.92510
90	0.92942	0.92922	0.92862	0.92754	0.92503
120	0.92936	0.92916	0.92856	0.92748	0.92497
150	0.92931	0.92911	0.92850	0.92743	0.92492
180	0.92927	0.92906	0.92846	0.92738	0.92488
210	0.92923	0.92902	0.92842	0.92734	0.92484
240	0.92918	0.92899	0.92839	0.92731	0.92481
270	0.92917	0.92896	0.92836	0.92728	0.92478
300	0.92915	0.92894	0.92834	0.92726	0.92475
330	0.92913	0.92892	0.92832	0.92724	0.92473
360	0.92911	0.92890	0.92830	0.92722	0.92471

(x) Effect of failure rates of horizontal band saw machine (β_3) on reliability of the system:

The reliability of the system has been computed by using the following combinations of failure and repair rates of different sub-systems and is given in Table. Here, we have taken $\beta_3 = 6.5, 5.5, 4.5, 3.5, 2.5$ and other parameters are taken as: $\alpha_1 = 0.00274, \alpha_2 = 0.001096, \alpha_3 = 0.01644, \alpha_4 = 0.00548, \alpha_5 = 0.00274, \alpha_6 = 0.0274, \alpha_7 = 0.04109, \beta_1 = 2.25, \beta_2 = 5.0, \beta_4 = 4.5, \beta_5 = 1.75, \beta_6 = 2.00, \beta_7 = 0.75$. It can be noticed from this table that the reliability of the system increases by approximately 0.35% with the increase in repair rate from 6.5 to 2.5 and decreases by approximately 0.05% with the increases in time from 30 to 360 days.

TABLE 2.2(c): EFFECT OF REPAIR RATE OF HORIZONTAL BAND SAW MACHINE (β_3) ON RELIABILITY OF THE SYSTEM

$\beta_3 \longrightarrow$	6.5	5.5	4.5	3.5	2.5
DAYS \downarrow					
30	0.92958	0.92918	0.92861	0.92771	0.92610
60	0.92949	0.92910	0.92853	0.92763	0.92602
90	0.92942	0.92903	0.92846	0.92756	0.92595
120	0.92936	0.92897	0.92840	0.92750	0.92589
150	0.92931	0.92892	0.92835	0.92745	0.92583
180	0.92927	0.92887	0.92830	0.92740	0.92579
210	0.92923	0.92884	0.92826	0.92736	0.92575
240	0.92918	0.92880	0.92823	0.92733	0.92572
270	0.92917	0.92877	0.9282	0.92730	0.92569
300	0.92915	0.92875	0.92818	0.92728	0.92567
330	0.92913	0.92873	0.92816	0.92726	0.92565
360	0.92911	0.92871	0.92814	0.92724	0.92563

(xi) Effect of repair rate of vertical band saw machine (β_4) on reliability of the system:

We now consider the effect of repair rate of vertical band saw machine on reliability of the system. Following value combinations of failure and repair rates of various sub-systems have been considered as $\alpha_1 = 0.00274$, $\alpha_2 = 0.01096$, $\alpha_3 = 0.01644$, $\alpha_4 = 0.00548$, $\alpha_5 = 0.00274$, $\alpha_6 = 0.0274$, $\alpha_7 = 0.04109$, $\beta_1 = 2.25$, $\beta_2 = 5.0$, $\beta_3 = 6.5$, $\beta_5 = 1.75$, $\beta_6 = 2.0$, $\beta_7 = 0.75$ and five levels of $\beta_4 = 4.5, 3.5, 2.5, 1.5, 0.5$. We have computed the reliability of the system using these parameters and it is given in Table. The results show that the reliability of the system increases by approximately 0.90% with the increase in the repair rate from 4.5 to 0.5 and decreases by approximately 0.05% with the increases in time from 30 to 360 days.

TABLE 2.2(d): EFFECT OF REPAIR RATE OF VERTICAL BAND SAW MACHINE (β_4) ON RELIABILITY OF SYSTEM

$\beta_4 \longrightarrow$	4.5	3.5	2.5	1.5	0.5
DAYS \downarrow					
30	0.92958	0.92928	0.92874	0.92748	0.92124
60	0.92949	0.92920	0.92866	0.92740	0.92116
90	0.92942	0.92913	0.92859	0.92733	0.92109
120	0.92936	0.92907	0.92853	0.92727	0.92103
150	0.92931	0.92901	0.92847	0.92722	0.92098
180	0.92927	0.92897	0.92843	0.92717	0.92094
210	0.92923	0.92893	0.92839	0.92713	0.92090
240	0.92918	0.92890	0.92836	0.92710	0.92087
270	0.92917	0.92887	0.92833	0.92707	0.92084
300	0.92915	0.92885	0.92831	0.92705	0.92081
330	0.92913	0.92883	0.92829	0.92703	0.92079
360	0.92911	0.92881	0.92827	0.92701	0.92078

(xii) Effect of repair rate of sizzling chamber (β_5) on reliability of the system:

The reliability of the system has been computed by using the following combinations of failure and repair rates of different sub-systems: $\alpha_1 = 0.00274$, $\alpha_2 = 0.001096$, $\alpha_3 = 0.01644$, $\alpha_4 = 0.00548$, $\alpha_5 = 0.00274$, $\alpha_6 = 0.0274$, $\alpha_7 = 0.04109$, $\beta_1 = 2.25$, $\beta_2 = 5.0$, $\beta_3 = 6.5$, $\beta_4 = 4.5$, $\beta_6 = 1.75$, $\beta_7 = 2.0$, $\beta_8 = 0.75$ and five levels of β_4 have been computed by the increment of 0.01 as $\beta_4 = 0.286, 0.296, 0.306, 0.316, 0.326$. The results show that the reliability of the system increases by approximately 0.12% with the increase in the repair rate from 0.286 to 0.326 and decreases by approximately 0.05% with the increases in time from 30 to 360 days.

TABLE 2.2(e): EFFECT OF REPAIR RATE OF SIZZLING CHAMBER (β_5) ON THE RELIABILITY OF SYSTEM

$\beta_5 \longrightarrow$	1.75	1.50	1.25	1.0	0.5
DAYS \downarrow					
30	0.92958	0.92957	0.92954	0.92951	0.92936
60	0.92949	0.92947	0.92943	0.92937	0.92907
90	0.92942	0.92939	0.92933	0.92924	0.92882
120	0.9936	0.92932	0.92924	0.92914	0.92861
150	0.92931	0.92926	0.92917	0.92905	0.92842
180	0.92927	0.92920	0.92911	0.92897	0.92826
210	0.92923	0.92916	0.92906	0.92890	0.92813
240	0.92918	0.92912	0.92901	0.92884	0.92801
270	0.92917	0.92909	0.92897	0.92879	0.92791
300	0.92915	0.92906	0.92894	0.92875	0.92783
330	0.92913	0.92903	0.92891	0.92871	0.92776
360	0.92911	0.92901	0.92888	0.92868	0.92769

(vii) Effect of repair rate of planner (β_6) on reliability of the system:

We again consider the failure and repair rates of different components as: $\alpha_1 = 0.0274$, $\alpha_2 = 0.01096$, $\alpha_3 = 0.01644$, $\alpha_4 = 0.00548$, $\alpha_5 = 0.00274$, $\alpha_6 = 0.02740$, $\alpha_7 = 0.04109$, $\beta_1 = 2.25$, $\beta_2 = 5.0$, $\beta_3 = 6.5$, $\beta_4 = 4.5$, $\beta_5 = 1.75$, $\beta_7 = 0.75$ with values of $\beta_6 = 2.0, 1.75, 1.5, 1.0, 0.5$. The table shows that the reliability of the system increases by approximately 4% with the increase of the repair rate from 2.0 to 0.5, but decreases by approximately 0.05% with the increases in time from 30 to 360 days.

TABLE 2.2(f): EFFECT OF REPAIR RATE OF PLANNER (β_6) ON RELIABILITY OF THE SYSTEM

$\beta_6 \longrightarrow$	2.0	1.75	1.5	1.0	0.5
DAYS \downarrow					
30	0.92958	0.92788	0.92564	0.91789	0.89538
60	0.92949	0.92778	0.92554	0.91781	0.89530
90	0.92942	0.92770	0.92546	0.91774	0.89524
120	0.92936	0.92763	0.92539	0.91769	0.89518
150	0.92931	0.92757	0.92533	0.91764	0.89513
180	0.92927	0.92752	0.92528	0.91759	0.89509
210	0.92923	0.92747	0.92523	0.91755	0.89506
240	0.92918	0.92743	0.92520	0.91752	0.89503
270	0.92917	0.92740	0.92516	0.91749	0.89500
300	0.92915	0.92737	0.92513	0.91747	0.89498
330	0.92913	0.92735	0.92511	0.91745	0.89496
360	0.92911	0.92733	0.92509	0.91743	0.89494

(viii) Effect of repair rate of final inspection (β_7) on reliability of the system:

The effect of repair rate of final inspection (β_7) on the reliability of the system is studied by varying its values as $\beta_7 = 0.75, 0.65, 0.55, 0.35, 0.25$ and other parameters are taken as: $\alpha_1 = 0.00274, \alpha_2 = 0.01096, \alpha_3 = 0.01644, \alpha_4 = 0.00548, \alpha_5 = 0.00274, \alpha_6 = 0.0274, \alpha_7 = 0.04109, \beta_1 = 2.25, \beta_2 = 5.0, \beta_3 = 6.5, \beta_4 = 4.5, \beta_5 = 1.75, \beta_6 = 2.0$. The table shows that the reliability increases by approximately 9.25% with the increase in the repair rate of final inspection (β_7) but decreases by approximately 0.05% with the increases in time.

TABLE 2.2(g) : EFFECT OF REPAIR RATE OF FINAL INSPECTION (β_7) ON RELIABILITY OF THE SYSTEM

$\beta_7 \longrightarrow$	0.75	0.65	0.55	0.35	0.25
DAYS \downarrow					
30	0.92958	0.92235	0.91268	0.87846	0.84368
60	0.92949	0.92227	0.91260	0.87838	0.84359
90	0.92942	0.92221	0.91253	0.87832	0.84354
120	0.92936	0.92215	0.91248	0.87827	0.84349
150	0.92931	0.92210	0.91243	0.87823	0.84345
180	0.92927	0.92205	0.91238	0.87819	0.84341
210	0.92923	0.92201	0.91235	0.87815	0.84338
240	0.92918	0.92198	0.91231	0.87812	0.84335
270	0.92917	0.92195	0.91229	0.87810	0.84332
300	0.92915	0.92193	0.91226	0.87807	0.84331
330	0.92913	0.92191	0.91224	0.87806	0.84329
360	0.92911	0.92189	0.91223	0.87804	0.84328

2.4 ANALYSIS OF RESULTS

Detailed study of Table 2.1 (a) to Table 2.1(g) and Table 2.2(a) to Table 2.2(g) reveals that the sub-systems, namely, Log length cutting and Final inspection has maximum effect on the reliability of the system Other systems are almost equally effective. Hence it is suggested that management should take care of these sub-systems to increase overall performance of the plant.

**AVAILABILITY MODEL OF TIMBER PROCESSING
PLANT**

3.1 MATHEMATICAL FORMULATION OF THE SYSTEM R

In process industries, management is generally interested in the long run availability of the system. We need the steady state probabilities of the system are obtained by taking $\frac{d}{dt} \rightarrow 0$ as $t \rightarrow \infty$. In this state, system of differential equations 2.1 reduces to the following system of linear equations. Here again we have used the symbol $P_j(t \rightarrow \infty)$

$$\begin{aligned}
 \lambda_1 P_1(t) &= \beta_1 P_3(t) + \beta_2 P_4(t) + \beta_3 P_5(t) + \beta_4 P_6(t) + \beta_5 P_7(t) + \beta_6 P_8(t) + \beta_7 P_9(t) \\
 \lambda_2 P_2(t) &= \beta_1 P_{10}(t) + \beta_2 P_{11}(t) + \beta_3 P_{12}(t) + \beta_4 P_{13}(t) + \beta_6 P_{14}(t) + \alpha_5 P_1(t) + \beta_7 P_{15}(t) \\
 \beta_1 P_3(t) &= \alpha_1 P_1(t) \\
 \beta_2 P_4(t) &= \alpha_2 P_1(t) \\
 \beta_3 P_5(t) &= \alpha_3 P_1(t) \\
 \beta_4 P_6(t) &= \alpha_4 P_1(t) \\
 \beta_5 P_7(t) &= \alpha_5 P_1(t) \\
 \beta_6 P_8(t) &= \alpha_6 P_1(t) \\
 \beta_7 P_9(t) &= \alpha_7 P_1(t) \\
 \beta_1 P_{10}(t) &= \alpha_1 P_2(t) \\
 \beta_2 P_{11}(t) &= \alpha_2 P_2(t) \\
 \beta_3 P_{12}(t) &= \alpha_3 P_2(t) \\
 \beta_4 P_{13}(t) &= \alpha_4 P_2(t) \\
 \beta_6 P_{14}(t) &= \alpha_6 P_2(t) \\
 \beta_7 P_{15}(t) &= \alpha_7 P_2(t)
 \end{aligned} \tag{3.1}$$

Where,

$$\lambda_1 = \alpha_1 + \alpha_2 + \alpha_3 + \alpha_4 + \alpha_5 + \alpha_6 + \alpha_7$$

$$\lambda_2 = \alpha_1 + \alpha_2 + \alpha_3 + \alpha_4 + \alpha_5 + \alpha_6 + \alpha_7$$

with initial conditions $P_1(0)=1$ and 0, otherwise.

The system of linear equation (3.1) with the normalizing equation

$$\sum_{i=1}^{15} P_i(t) = 1 \quad (3.2)$$

Can be solved numerically using Gauss elimination method to find all the probabilities. Finally, long run availability of the timber processing plant for the various choices of the failure and repair rates of the system can be obtained by

$$A(\infty) = \sum_{i=1}^2 P_i(t) \quad (3.3)$$

with initial conditions $P_1(0)=1$ and 0, otherwise.

3.2 BRIEF INTRODUCTION TO TIMBER PROCESSING PLANT

Bharat saw mill was set up in 1982 in Sirhind, a small urban city situated on NH1 nearly equal distance of 35 kms from Patiala and Rajpura (Punjab). As now a days Indian Timber is banned so timber Logs imported from Malaysia is processed for following purposes:

1. Long Length timber used for fabrication of truck body
2. Medium length timber used for manufacturing of doors and windows
3. Short sizes used for furniture manufacturing

3.3 INDUSTRIAL SIGNIFICANCE OF THIS STUDY

As Reliability becomes very important factor of every product in industry, the techniques discussed in this thesis are designed for studying the problems of reliability. As reliability is often calculated in industrial problems. These factors help in future planning so that industry can get more profit and also helps in the manufacture of more reliable products. Our analysis of the result is based on the actual data of failure and repair rates of the system. The conclusion drawn from the analysis is consistent with the actual performance of the manufacturing plant. Our suggestions will help them a lot to increase over-all performance of their system.

3.3 LIMITATIONS AND FUTURE SCOPE OF THE PRESENT STUDY

In the present work, to solve the differential equations with given initial conditions, we have used Runge-Kutta fourth order method. The reliability of the system has been calculated for 360 days. The calculations are performed by taking $h = 0.005$. One can use another numerical method for solving this problem.

In our present study while computing the reliability of processing plant, we are not considering the cost required for the repair of sub-systems. The cost factor plays very important role to get the maximum reliability of a system. In future one can study the optimal reliability of the system by the consideration of cost factor and achieve the maximum reliability with minimum cost.

REFERENCES

1. Cox. D.R (1955), Analysis of non-Markovian stochastic processes by the inclusion of supplementary variables, *proc. comb. Phil. Soc.*, 51,pp.433-441
2. Singh, J. (1980), Effect of switch failure on 2-redundant system, *IEEE Trans. On Relia.*, 29(1),pp.82-83
3. Mohan, C. and Garg, R.C. (1962), Dependability of a system with general failure time and exponential repair time distribution, *Operational research Quarterly*
4. Linton, D.G. and Saw, J.G (1974),Reliability analysis of the K out of N: F –system, *IEEE Trans. Reliab.*, R-23,pp.97-103
5. Dummer, G. and Griffen, N. (1960), *Electronic Equipments Reliability*, John Wiley & sons, N.Y.
6. Habchi Georges, (2002), an improved method of reliability assessment for suspended tests, *International Journal of Quality and Reliability Management*, Vol. 19, No.4, pp. 454-470.
7. William, H.C. (1959), *Automotive Transmission and Power Trans.*, McGraw Hill Book Company, N.Y.
8. Barlow, R.E., Hunter, L.C. (1967), Reliability analysis of a one-unit system, *Opns. Res*, (9).
9. Hosford, J.E. (1960), Measures of Dependability, *OPSEARCH*, (8).
10. Lambert, J.C., Dugdill, B., Draayer, J. and Bennett, A. (2000), an introductory paper on overview of small scale milk collections and processing in developing countries, *Animal Productions Services*, FAO, Rome, Italy.
11. Barlow, R.E., Hunter, L.C. and Proschan, F. (1967), *Mathematical Theory of Reliability*, John Wiley.
12. Gagloft, W. C. (1975), Common mode failure analysis, *IEEE Trans. Power apparatus system*,94,pp 27-30.
13. Dhillon, B.S. and Singh C. (1981), *Engineering – Reliability- New Techniques and applications*, John Wiley, New York.

14. Dhillon, B.S (1980), Mechanical component reliability under environmental stress, *Micro. And Relib.*, 20 (12).
15. Dhillon, B.S (1977), A 4 unit redundant system with common cause failures, *IEEE Trans. Reliability*, R-26, pp. 373-374
16. Kapoor P.K. and Kapoor R.K. (1976), Effect of standby redundancy on system Reliability, *IEEE Trans, Reliab.*, R-25, pp. 72-75.
17. Chug, W.K. (1990), a reliability analysis of K-out- of-N: G reluctant system with common cause failure and critical human error , *Micro. And Rel.*,30, pp. 237-397.
18. Cate, C.L.et al (1977), Common cause failure analysis methodology for complex systems, *Proce. Of society for industrial and applied mathematics*, 33, South, 17 st. Philadelphia, Pennsy vania, U.S.A.
19. Srinath L.S., *Reliability Engineering*, East-West Press, 1985.
20. Gupta Pawan (2003), *Mathematical Analysis of Reliability and Availability of some Process Industries*, Ph. D. Thesis Thapar University Patiala.
21. Aggarwal, M. and Kumar, Ashok (1980), A review of standby system, *IEEE Trans. Reliab.*, R-29, pp.290-294
22. Pawan Gupta, A. K. Lal, R. K. Sharma and J. Singh, Analysis of Reliability and Availability of Serial Process of Plastic-Pipe Manufacturing Plant-a case study, *international Journal of Quality and Reliability Management*, 24(4), 404-419,2007.
23. Lata Sneha , *Reliability Analysis of Piston Manufacturing Plant*, M. Sc. Dissertation, Thapar University, Patiala, (2009)