

A Novel Rate-2 Space Time Block Code & implementation of its decoder

Dissertation submitted in partial fulfilment of the requirements
for the award of degree of

MASTER OF TECHNOLOGY

In

VLSI Design

Submitted By

Kumar Utkarsh Keshari

Roll No. 601261015

Under guidance of

Dr. Sanjay Sharma

Professor, ECED

Thapar University

Patiala



Department of Electronics and Communication Engineering

THAPAR UNIVERSITY

(Established under the section 3 of UGC Act, 1956)

PATIALA-147004 (PUNJAB)

JULY, 2014

DECLARATION

I hereby declare that the work which is being presented in the dissertation entitled, "A Novel Rate-2 Space Time Block Code & Implementation of its Decoder" in partial fulfilment of the requirement for the award of degree of Master of Technology in VLSI Design submitted in Electronics & Communication Department of Thapar University, Patiala, is an authentic record of my own work carried out under the supervision of Dr. Sanjay Sharma, HOD & Professor, ECED and refers other researcher's work which are duly listed in the reference section.

The matter presented in this dissertation has not been submitted in any other University/Institute for the award of degree.

Date: 14/07/2014

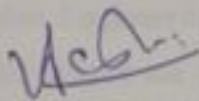

(KUMAR UTKARSH KESHARI)

Roll No: 601261015

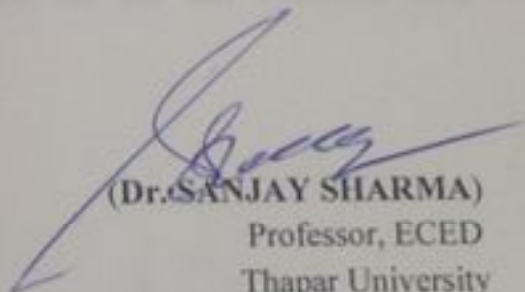
It is certified that the above statement made by the student is correct to the best of my knowledge and belief.

(Dr. SANJAY SHARMA)
Professor, ECED
Thapar University
Patiala-147004

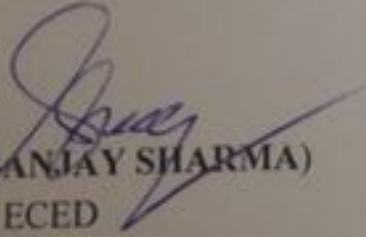
Countersigned by:

(Dr. SANJAY SHARMA)
Head, ECED
Thapar University
Patiala-147004

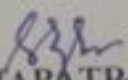
(Dr. S. K. MOHAPATRA)
Dean (Academic Affairs)
Thapar University
Patiala-147004

ACKNOWLEDGEMENT

To express one's regards words are often less. I take this opportunity to express my profound sense of gratitude and respect to all those who helped me throughout the duration of this dissertation.

I wish to express earnest acknowledgement and gratitude to **Dr. Sanjay Sharma, HOD & Professor**, Electronics and Communication Engineering Department, Thapar University, Patiala for his patient guidance and support throughout this dissertation. I am truly fortunate to have the opportunity to work with him. I found his guidance to be extremely valuable and his feedback and editorial comments quite generous and helpful for the writing this dissertation.

I am also thankful to our **PG Coordinator, Dr. Kulbir Singh, Associate Professor**, and the entire faculty & staff of Electronics and Communication Engineering Department along with my friends who devoted their valuable time and helped me in all possible ways towards successful completion of this work. I thank all those who have contributed directly or indirectly to this work

Lastly, I would like to thank my parents for their years of unyielding love and encouragement. They have always wanted the best for me and I admire their determination and sacrifice.

(KUMAR UTKARSH KESHARI)

ABSTRACT

Wireless communications have been developed widely and rapidly in the modern world especially during the last decade. Recent advancement in wireless communication systems has entailed the development of various coding technique. Through these coding techniques, the reliability of wireless communication has also been increased. Space time block codes have achieved the high spectral efficiency, low complexity and good error performance in continued research in this field. But still the demand of higher rate of transmission is endless.

In this thesis, we present a new high rate space time block code for two transmit antenna and one receive antenna. The presented Space Time Block Code transmits two symbols per time slot. Hence the code achieves double data rate of transmission. Using QPSK modulation technique, a data rate of 4 bits/Hz/sec has been achieved instead of 2 bits/Hz/sec. It has been shown that if perfect channel state information is available at the receiver, the higher rate of transmission can be achieved. In this thesis, we have designed a new decoder of the proposed code and implemented it on FPGA board to show the practicability of the decoder. VHDL is used for the development of decoder. Results are simulated on ModelSim simulator. Synthesis report shows that complexity of decoder is approximately same as that of conventional methods. Practicability of the proposed rate-2 Space Time Block Code has been proved in this thesis.

TABLE OF CONTENTS

Declaration.....	i
Acknowledgement.....	ii
Abstract.....	iii
Table of contents.....	iv
List of Figures.....	vi
List of Tables.....	vii
List of Abbreviations.....	viii
CHAPTER 1 INTRODUCTION.....	1-14
<hr/>	
1.1. Overview.....	1
1.2. History & Background.....	1
1.2.1. Timeline.....	2
1.3. Wireless Applications.....	3
1.4. Necessity of Coding.....	4
1.5. Channel Model.....	5
1.5.1 AWGN Channel Model.....	7
1.5.2 Rayleigh Fading Channel.....	7
1.6 Diversity.....	8
1.6.1 Temporal Diversity.....	9
1.6.2 Frequency Diversity.....	9
1.6.3 Spatial Diversity.....	9
1.6.4 Angular Diversity.....	10
1.6.5 Polarization Diversity.....	10
1.7 Capacity.....	10
1.8 MIMO Wireless Communication.....	11
1.9 Transmission Model for MIMO System.....	12
1.10 Problem Formulation.....	14
1.11 Objective.....	14
1.12 Dissertation Outline.....	14
CHAPTER 2 LITERATURE SURVEY.....	15-18
<hr/>	
CHAPTER 3 GENERALITIES OF SPACE TIME BLOCK CODE.....	19-34
<hr/>	
3.1 Introduction.....	19

3.2 Design Criteria.....	19
3.2.1 Rank & Determinant Criterion.....	20
3.2.2 Trace Criterion.....	21
3.2.3 Maximum mutual Information Criterion.....	21
3.3 Space time Block Code.....	21
3.3.1 Alamouti Code.....	21
3.4 STBC for more than two Transmit Antenna.....	26
3.4.1 Space Time Block Encoder.....	27
3.4.2 STBC for real signal constellation.....	28
3.4.3 STBC for complex signal constellation.....	31
3.4.4 Decoding of STBC.....	33
CHAPTER 4 FPGA IMPLEMENTATION.....	35-41
<hr/>	
4.1 Introduction.....	35
4.2 Simulation Tools.....	35
4.2.1 Structure of VHDL Code.....	35
4.2.2 Modeling styles in VHDL.....	36
4.3 Synthesis	
Tool.....	36
4.3.1 Xilinx ISE Design suite 13.2.....	36
4.4 FPGA Design flow.....	37
CHAPTER 5 PROPOSED WORK	42-48
<hr/>	
5.1 Introduction.....	42
5.2 Proposed Code.....	42
5.3 Hardware Design.....	44
5.4 Simulation, FPGA Implementation & Results.....	45
CHAPTER 6 CONCLUSION AND FUTURE WORK	49-50
<hr/>	
6.1 Conclusion.....	49
6.2 Future Scope.....	50
LIST OF PUBLICATIONS.....	51
REFERENCES.....	52-53

LIST OF FIGURES

Figure 1.1: Block diagram of Communication System.....	4
Figure 1.2: AWGN Model.....	7
Figure 1.3: Block diagram of MIMO system.....	13
Figure 3.1: A block diagram of the Alamouti space time encoder.....	21
Figure 3.2: Receiver for the Alamouti scheme.....	24
Figure 3.3: Performance of the Alamouti code.....	26
Figure 3.4: Decoder block diagram for Alamouti with MRC.....	26
Figure 3.5: Block diagram of STBC Encoder.....	27
Figure 3.6: Performance of STBC on Rayleigh fading channel with one receive antenna.....	34
Figure 4.1: FPGA Design flow.....	38
Figure 4.2: Flow of Synthesis Process.....	40
Figure 4.3: Different Files Generated in Implementation Process.....	41
Figure 5.1: Performance of proposed Rate 2 code for 2x1 antenna.....	44
Figure 5.2: Architecture of Novel Rate 2 Decoder.....	45
Figure 5.3: Top Level RTL of Proposed Architecture.....	46
Figure 5.4: Behavioral Simulation of Proposed Decoder.....	46
Figure 5.5: Expanded view of partial RTL Schematic.....	47
Figure 5.6: RTL Schematic.....	48

LIST OF TABLES

Table 5.1: Hardware Comparison of different decoders..... 47

LIST OF ABBREVIATIONS

AWGN	Additive white Gaussian Noise
CSI	Channel State Information
FPGA	Field Programmable Gate Array
IEEE	Institute of Electrical and Electronics Engineers
LTE	Long Term Evolution
MIMO	Multiple Input Multiple Output
QOSTBC	Quasi Orthogonal Space Time Block Code
QPSK	Quadrature Phase Shift Keying
RTL	Register Transfer Level
SNR	Signal-to-Noise Ratio
STBC	Space Time Block Code
VHDL	Very High Speed Integrated Circuit Hardware Description Language
VLSI	Very Large Scale Integration
WLAN	Wireless Local Area Network

CHAPTER

1

INTRODUCTION

1.1 OVERVIEW

Today's life cannot be imagined without wireless in some form or the other. Wireless industry was pioneered by Marconi about 100 years ago. Wireless communication is one of the fastest growing industries [1, 2, 3]. Portability, mobility, and accessibility are main driving force behind the rapid development of wireless communication. Wired communication is more stable and highly reliable, but confines the user to a bounded environment. Logically people choose freedom versus confinement. The penalty for freedom is lower quality, privacy, security, or lower throughput compared to wired solution.

A significant advancement in the wireless communication began when Shannon published his paper "A Mathematical theory of Communication" [4]. In this paper Shannon told that how information can be transmitted reliably. He discussed that channel coding should be used to improve the communication performance. By encoding a signal in such a way that it can better withstand the effect of channel fading. Channel coding is a process of signal transformation to improve the performance.

1.2 HISTORY & BACKGROUND

The history of communications dates back to 3500 B.C when the Sumerians developed cuneiform writing and the Egyptians developed hieroglyphic writing. It was then that the human race started developing different ways of communicating their messages. The major breakthrough in telecommunications came when Samuel Morse invented the Morse code.

1.2.1 TIMELINE

The timeline of telecommunications is given below:

- 1793 - The Chappe brothers established the first commercial semaphore system between two locations near Paris.
- 1837 - Cooke and Wheatstone obtain a patent on telegraph. Morse publicly demonstrates his telegraph.
- 1843 - FAX invented by the Alexander Bain.
- 1844 - Electric telegraph was demonstrated by Samuel Morse. This was a major breakthrough in communications and marked the beginning of a new era.
- 1865 - James Clark Maxwell invents four simple electromagnetic equations that describe all known electromagnetic phenomena of the time.
- 1864 - James Clerk Maxwell proves that wireless telegraphy is possible.
- 1866 - The first Transatlantic telegraph cable is laid.
- 1876 - Alexander Graham Bell invents the telephone.
- 1895 - Guglielmo Marconi invented the radio.
- 1901 - Marconi completes the first transatlantic radio transmission from Newfoundland.
- 1907 - The world's first transatlantic commercial wireless services is established by Marconi with stations at Clifden, Ireland and Glace Bay, Nova Scotia.
- 1909 - Marconi gets a joint Nobel Prize in Physics, with Karl Ferdinand Braun because of their work in the development of wireless telegraphy.
- 1910 - Thomas Edison demonstrated the first talking motion picture.
- 1925 - John Logie Baird transmits the first experimental television signal.
- 1934 - Joseph Begun invents the first tape recorder for broadcasting first magnetic recording.
- 1940's - Spread Spectrum

Before 1948, communication was strictly an engineering discipline, with little scientific theory to back it up. In 1948, Claude E. Shannon known as, “The Father of Information Theory” published his ground breaking work and altered our basic think about communication. In his paper two major concepts were given:

1. The concept of information and the modelling of information sources.

2. The concept of a channel and on the limits of reliable communication on unreliable channels.

Given a communication channel, Shannon proved that there exists a number, called the capacity of the channel, such that reliable transmission is possible for rates arbitrarily close to the capacity, and reliable transmission is not possible for rates above capacity. He demonstrated that it is possible to achieve error free transmission on a noisy communication channel through coding. His work focuses on the problem of how best to encode the information a sender wants to transmit. This paper was the beginning of a new era in the field of error control coding.

More than a decade ago in 1993, C. Berrou and A. Glavieux [5] presented a new scheme for channel codes decoding: the turbo codes, and their associated turbo decoding algorithm. Turbo codes made possible to get within a few tenth of dB away from the Shannon limit, for a bit error rate of 10^{-5} . This made other researchers realize the importance of iterative decoding and also made them aware that other capacity approaching codes existed. Recently, LDPC codes have attracted much attention in the world of coding. They were originally invented in the 1960's and forgotten. They were again brought to life in 1995 by Mackay and Neal [6]. Unlike many other classes of codes LDPC codes are already equipped with very fast encoding and decoding algorithms.

In 1998, Alamouti presented a breakthrough paper, in which he described a code which achieves the capacity near to the Shannon capacity with a very low decoding complexity. Alamouti utilizes the space diversity to reduce the error rate of the received signals. This makes LDPC codes not only attractive from a theoretical point of view, but also perfect for practical applications. They are already being implemented in modern wireless communication such as LTE [7], IEEE 802.11n [8], and WiMax [9].

1.3 WIRELESS APPLICATIONS

Today's era employ wireless communication in many systems. One of the earliest successful application of wireless communication is perhaps radio broadcasting. Television broadcasting and satellite communication are important examples. Recent interest in wireless communication is inspired by the establishment of the first generation cellular phones. The first generation of mobile cellular phones appeared in early 1980s. First generation cellular phones used analog transmission. The second generation of cellular transmission systems, used digital transmission was introduced in 1990s. Both of

these two systems were designed to transmit speech and have a maximum data rate 9.6 kbps. More advanced services were called 2.5 generation. These were designed for up to 100kbps data transmission. Recently, the third generation mobile system is being considered for high bit-rate services. The third generation systems are designed to transmit the data at 144-384 kbps for fast moving and up to 2.048 Mbps for slow moving users. Third generation mobile system includes a Time division multiple access (TDMA) scheme known as Enhanced data for global evolution (EDGE) standard. It also includes two standards based on wideband code division multiple access (CDMA). One is synchronous System called CDMA2000 and other one is an asynchronous system named WCDMA. In third generation standard multiple services can be used simultaneously.

Another important application that demands for high bit rate and spectral efficiency is wireless local area networks (WLANs). The most successful WLAN standard is based on orthogonal frequency division multiplexing (OFDM), which allows the data transmission up to 54 Mbps.

1.4 NECESSITY OF CODING

With the increase transmission rate of data there is need to utilize the bandwidth efficiently. There are two main requirement of coding.

- Reproduce probability of error for finite block of symbol
- To approach towards the channel capacity

Consider the basic communication system as shown in figure-1.1. In this source produce R bits per second at fixed rate. The encoder is a device that prepares the data for transmission. We assume encoder makes the block of bits and each block has B bits. Encoder operates independently on each block. Encoder output then transmitted over channel and disturbed by the noise in channel. Decoder process the channels output and produce the delay version of the source bits.

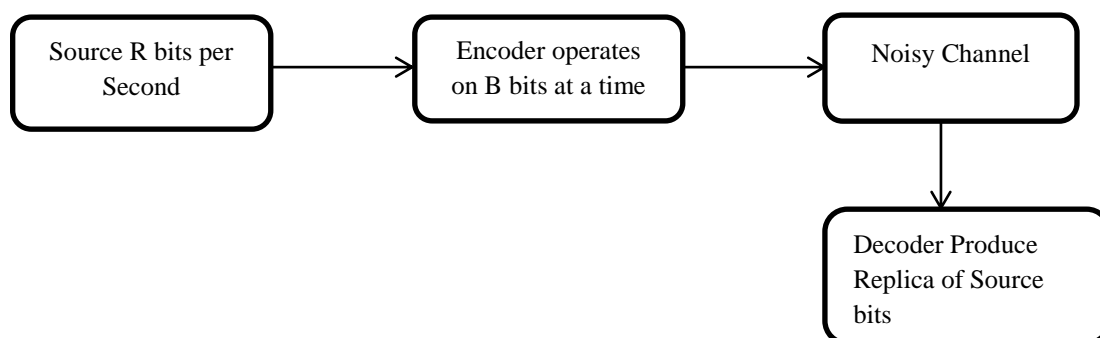

Figure 1.1: Block Diagram of Communication System

If one element is sent on channel then it can be received in two possible ways, then good communication on channel does not occur. For this multiple element are sent at the place of one element. But if these elements are not correlated then it does not help us anymore. Due to this multiple correlated elements are sent.

Shannon theorem shows that, sequence of code, have capability of correcting all errors as the code length goes to infinity. Capacity of channel according to the Shannon is:-

$$C = W \log_2(1 + S/N) \quad (1.1)$$

OR

$$C = 1 - H(p)$$

Here, C = Channel capacity, it means one bit contain C part of information.

W = Bandwidth

S/N= Signal to Noise ratio

H(p) = entropy function of 'p' i.e. $[-p \log_2 p - (1 - p) \log_2 (1 - p)]$

P = probability of error

So to increase the capacity, signal to noise ratio should be high i.e. noise should be less. In other words noise probability should be less.

According to noise channel coding theorem of the Shannon, the size of 'B' should be large. Due to this, coding schemes are used to increase the block length 'B' which in turn decrease the error probability but it is very difficult to implement practical encoder and decoder with very large block length.

1.5 CHANNEL MODEL

From the transmitter to the receiver, wireless channels operate through electromagnetic radiation. Electromagnetic waves propagate through environments where they are reflected, scattered, and diffracted by walls, terrain, buildings, and other objects. Transmitted waves are received at receiver through many different paths. These separate versions of signal experiences different path loss and phases. At the receiver all received signals are accumulated together creating a non-additive white Gaussian noise (AWGN) model for wireless channel. It is often difficult to obtain an accurate deterministic channel model due to difficult calculation of electromagnetic wave equation taking into

consideration of all the obstruction caused by ground, buildings, and vehicles. Thus we resort to the statistical models to characterize the signal propagation.

There are two main characterization of wireless channel in terms of channel length variation over time.

- Large-scale fading or *Attenuation*
- Small-scale fading or just *Fading*

Large scale fading corresponds to the characterization of the signal power over large distances or the large time interval. This is called attenuation or path loss and sometimes large scale fading. Small scale fading is the characterization of the signal where amplitude and power of the signal changes rapidly. It relates to the characterization of the signal over short distance or short time intervals.

Attenuation or large scale fading is caused by many factor including propagation losses, antenna losses, and filter losses. The average received signal power decreases logarithmically with distance in large scale fading. The logarithmic factor, or path gain exponent, depends on the propagation medium between transmitter and receiver.

Fading or small scale occurs due to the constructive and destructive interference of the multiple signal paths between transmitter and the receiver. The received combined signals vary widely in amplitude and phase. The rapid fluctuation of the amplitude of the signal over a short period of time more effective compared large scale path loss effects. Hence large scale path loss effects can be ignored.

The *fading* channels can be classified based on their multipath time delay into flat and frequency selective and based on Doppler spread into slow and fast. These two phenomena are independent of each other and result in the following four types of fading channels:-

- Flat Slow Fading or Frequency Non-Selective Slow Fading: When the bandwidth of the signal is smaller than the coherence bandwidth (the range of frequencies in which the channel response appears to be “flat”, i.e., same gain and phase response) of the channel and the signal duration is smaller than the coherence time (the duration of time in which the channel appears to be static) of the channel.

- Flat Fast Fading or Frequency Non-Selective Fast Fading: When the bandwidth of the signal is smaller than the coherence bandwidth of the channel and the signal duration is larger than the coherence time of the channel.
- Frequency Selective Slow Fading: When the bandwidth of the signal is larger than the coherence bandwidth of the channel and the signal duration is smaller than the coherence time of the channel.
- Frequency Selective Fast Fading: When the bandwidth of the signal is larger than the coherence bandwidth of the channel and the signal duration is larger than the coherence time of the channel.

Here we review two of the most commonly used channel models, namely the additive white Gaussian noise (AWGN) and Rayleigh fading channel models.

1.5.1 AWGN CHANNEL MODEL

Additive white Gaussian noise channel model is shown in figure 1.2, in which the only degradation to communication is a linear addition of noise with a constant spectral density and a Gaussian distribution of amplitude. The model can be described mathematically as

$$r(t) = x(t) + n(t) \quad (1.2)$$

Where $r(t)$ and $x(t)$ are the received and transmitted signals respectively and $n(t)$ is the noise, at time t , represented as a Gaussian random process with zero mean and variance N_0 . The noise $n(t)$ is assumed to be independent of the signal $r(t)$.

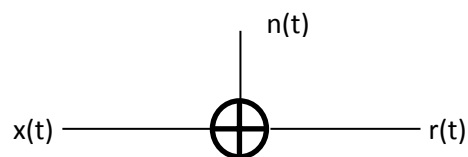

Figure 1.2: AWGN Channel Model

1.5.2 RAYLEIGH FADING CHANNEL MODEL

In Rayleigh fading channel, the received signal is impaired by multipath fading as well as AWGN. Based on coherence bandwidth of the channel and bandwidth of the signal, it can be divided into two models.

Narrowband systems or flat frequency: - In this type of systems, the transmitted signals usually occupy a bandwidth smaller than the channel's coherence bandwidth; this type is also referred to as frequency non-selective as all frequency of signal is faded equally.

Wideband systems: - In this type of systems, the transmitted signal bandwidth is greater than the channel coherence bandwidth, Hence the spectral components of the transmitted signal with a frequency separation larger than the coherence bandwidth are then faded independently.

In the presence of flat or frequency non-selective fading, the received signal in complex baseband form can be expressed as

$$r(t) = h(t)x(t) + n(t) \quad (1.3)$$

Where, $x(t)$ and $r(t)$ are the transmitted and received complex baseband signals, respectively, and $h(t)$ is the channel state information (CSI). $h(t)$ causes the transmitted signal a random phase rotation and random amplitude fluctuation.

1.6 DIVERSITY

The fading of channel results in inefficient and unreliable transmission of data. Fading channel suffers from sudden declines in the power due to the destructive addition of multipath signals in the propagation media. Decline in power of signal can also be caused by interference from other users. Therefore, the effective signal-to-noise (SNR) at the receiver can be dropped dramatically. One possible, but no-pragmatic, solution to combat this degradation are to increase transmission power, antenna size, or antenna height. The other and practical alternative to these solutions would be is to provide different replicas of the transmitted signal to the receiver. It is less probable to have all copies of the transmitted signal in deep fade simultaneously. The different replicas of received signal fade independently. Therefore, the receiver can decode the transmitted signal reliably using these received signals. Decoding can be performed by picking the signal with the highest SNR or by combining the multiple received signals. This scheme of transmission and reception is called diversity. This is most important technique of wireless communication to mitigate the effect of fading.

Several techniques of achieving diversity are available. Some of them are discussed below.

1.6.1 TEMPORAL DIVERSITY

In temporal or time diversity, replicas of the information signal are transmitted in different time slots. To achieve time diversity, two adjacent time intervals must be separated for more than coherence time of the channel so that the replicas of the signal experience independent fades. In this manner, we get multiple uncorrelated repetitions of the signal at the receiver.

Time diversity provides multiple replica of signal without increase in power of transmitted signal, but it does decrease the data rate since data is repeated in the diversity time slots rather than sending new data in these time slots. Thus, this scheme is not bandwidth efficient due to redundancy.

1.6.2 FREQUENCY DIVERSITY

In frequency diversity, different carrier frequencies are used to transmit different replicas of information signal. To achieve diversity, the carrier frequencies must be separated by more than coherence bandwidth of the channel so that the replicas of the signal experience independent fades.

Frequency diversity suffers from bandwidth deficiency. It also requires additional transmit power to send the signal over multiple frequency bands. For every carrier frequency, the receiver has to be tuned.

1.6.3 SPATIAL DIVERSITY

Multiple transmit and/or receive antenna are used in spatial or antenna diversity. These are also called an antenna array and each element in the array are separated in distance. The minimum distance between two adjacent antennas must be at least half of the signal wavelength to achieve diversity. In this manner, signal corresponding to different antenna fade independently.

Spatial diversity does not suffer from bandwidth deficiency as is the case in temporal and frequency diversity. But the use of multiple antennas has an area constraint in small handheld devices, due to the fact that a minimum physical separation is needed between antennas to achieve diversity.

There are two types of spatial diversity: receive diversity and transmit diversity. In case of receive diversity, independent fading paths are realized without an increase in transmit signal power or bandwidth. In case of transmit diversity, the transmit power is divided among multiple antenna.

1.6.4 ANGULAR DIVERSITY

To achieve angular diversity directional antennas are used. The beamwidth of receive antenna is restricted to a certain angle by the use directional antenna at the receiver. Different copies of the transmitted signals are collected from different angle. Hence the received signal via multiple paths appears to be uncorrelated.

Angular diversity is good for small devices due to the fact that it does not need to separate physical locations of antennas like spatial diversity. However, requires a sufficient number of directional antennas to span all possible directions of arrival.

1.6.5 POLARIZATION DIVERSITY

In polarization diversity, signals are polarized horizontally and vertically to achieve diversity. Since the scattering angle relative to each polarization is random, it is highly improbable that signals received on the two differently polarized antennas would be simultaneously in deep fades.

Unlike *spatial* diversity, *polarization* diversity does not require separate physical locations for the antennas. However, *polarization* diversity can only provide a diversity order of two and not more.

1.7 CAPACITY

Earlier, a reliable communication over noisy channel was achieved by reducing the data rate. In 1948, Claude Shannon invented information theory [4]. Shannon told that by intelligent coding of the information one can communicate at a positive rate with a small error probability as desired. However, there is a maximal rate, called the *capacity* of the channel, for which this can be done. It is impossible to achieve zero probability error, if data transfer is done above channel capacity.

The maximum achievable data rate for a system is called the capacity of the channel for which the arbitrarily low probability can be achieved. For digital transmission on a continuous AWGN channel, the capacity is given by the Shannon formula [4],

$$C = B \log_2 (1 + \rho) \quad (1.4)$$

Where, C represents the Shannon capacity (measured in units of bits/sec), B represents the channel bandwidth and ρ is the signal-to-noise ratio (SNR). Shannon theorem proves that codes exist, which achieve data rates arbitrarily close to capacity with arbitrarily small probability of error. The converse theorem shows that any code with rate $R > C$ has a probability of error bounded away from zero. Shannon capacity is generally used as an upper bound on the data rates that can be achieved under real system constraints as the proof of the theorem does not place any constraint on the delay or complexity of the communication system.

The Shannon capacity of fading channels, with receiver CSI only can be shown to be less than that of an AWGN channel with the same average SNR. In other words, fading reduces the Shannon capacity when CSI is only available at the receiver. It has also been noted that capacity-achieving codes for fading channels must be sufficiently long so that a received codeword is affected by all possible fading states. This can result in very long codewords and consequently long delays.

Large gains in available channel capacity are possible for wireless channels by using multiple-input multiple-output (MIMO) systems [10], which is current research trends in wireless communication. MIMO channels result when multiple antennas are employed at both ends of the wireless link. Theoretical and experimental evidence demonstrates that the available channel capacity grows linearly when the number of transmit and receive antennas grow simultaneously shown in [10, 11]. This provides added capacity with no increase in bandwidth.

1.8 MIMO WIRELESS COMMUNICATION

A Multiple-input and multiple-output, or MIMO channel can be realized with multi element array antennas. MIMO uses multiple antennas at both the transmitter and receiver to improve communication performance. MIMO achieves a significant increases in data throughput and link range without additional bandwidth or increased transmit power. It achieves this goal by spreading the same total transmit power over the antennas to

achieve an array gain that improves the spectral efficiency (more bits per second per hertz of bandwidth) or to achieve a diversity gain that improves the link reliability (reduced fading). MIMO schemes has attracted a lot of research attention provided that if channel knowledge is only available at the receiver [11].

Based on the channel knowledge at the receiver, MIMO modulation scheme can be divided into two category, diversity systems and spatial multiplexing systems. Diversity modulation or space time coding [12, 13, 14] maximizes diversity advantage of the transmitted information using codeword. These codes maximize diversity gain at the cost of some loss in available capacity. On the other hand, spatial multiplexing or Bell labs Layered Space Time (BLAST) type systems [11] transmit independent data streams from each transmitting antenna which achieves spectral efficiency at the loss of diversity advantage for a fixed number of antennas.

A space time coding work came into existence with the 1994 paper by Wittenben [15], which proposes a system using transmit diversity and coding techniques, followed by the ground-breaking paper by Tarokh, Sheshadri and Calderbank in 1998 [13] in which they presented fundamental theory of space time and introduce the first space time code, namely space-time trellis codes (STTCs). This paper was followed by the pioneer work of Alamouti's paper [12], which led to the development of Space-Time Block Code (STBC) [16, 17].

Initially, MIMO was used for indoor WLANs and fixed wireless access networks. However, it has found wider applications and some practical MIMO systems have been built and experimentally tested. Today MIMO is an important part of wireless communication standards such as IEEE 802.11n (Wi-Fi), 4G, 3GPP LTE WiMAX and HSPA+.

MIMO technology is used in non-wireless systems. One example is the home networking standards ITU-T G.9963, which defines a power line communications system that uses MIMO techniques to transmit multiple signals over multiple AC wires (phase, neutral and ground).

1.9 TRANSMISSION MODEL FOR MIMO SYSTEM

MIMO transmission environment can be modelled under certain assumption using complex numbers to represent the magnitude and phase change of the transmission

channel. In modelling the system it is assumed that channel is flat fading channel. A flat fading channel is that which produces same attenuation to all frequencies. One of the side effects of the flat fading is that there is no Inter-Symbol Interference (ISI).

We consider a communication system with N transmit antenna and M receive antenna, where N signals are transmitted from N transmitters simultaneously. At each time slot t , signals $C_{t,n}$, $n=1,2,\dots,N$ are transmitted simultaneously. These signals are the input for the MIMO channel and produces M outputs. Each transmitted signal goes through the wireless channel to arrive at each of the M receive antenna.

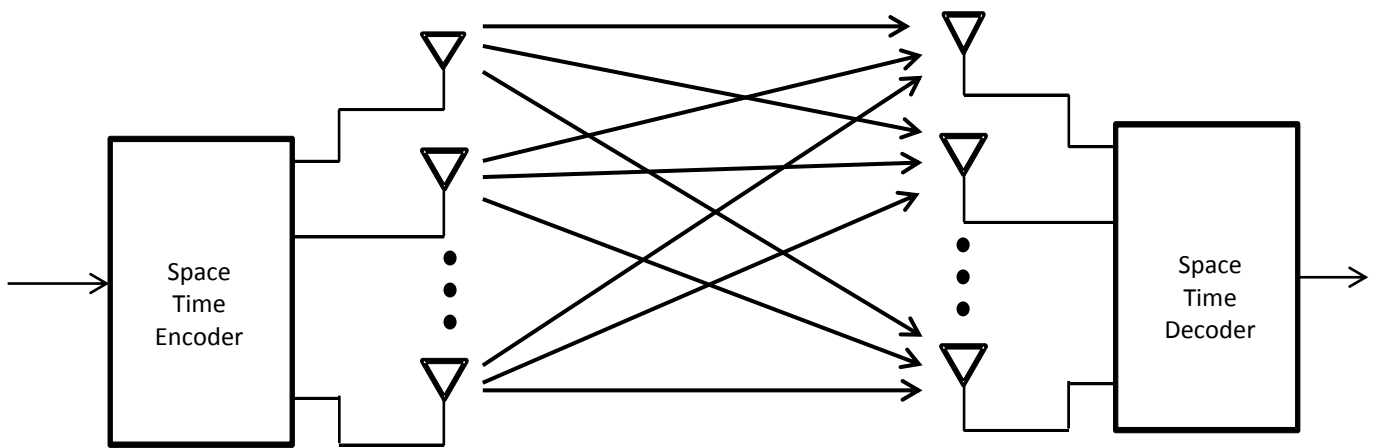

Figure 1.3: Block Diagram of MIMO system

In wireless communication system, each output of the channel is a linear superposition of the faded versions of the inputs with added noise. As shown in figure 2, each pair of transmit and receive antennas provides a signal path from the transmitter to the receiver. The coefficient $\alpha_{n,m}$ is the path gain from transmit antenna n to receive antenna m . Based on this model, the signal $r_{t,m}$, which is received at time t at antenna m , is given by

$$r_{t,m} = \sum_{n=1}^N \alpha_{n,m} C_{t,n} + \eta_{t,m} \quad (1.5)$$

Where $\eta_{t,m}$ is the noise sample of receive antenna m at time t . These M copies of the transmitted signal at the receiver end combined which creates an opportunity to provide diversity gain.

1.10 PROBLEM FORMULATION

All portable devices have a constraint of area; on the contrary, high rate of data transmission is today's necessity. Portable devices have only one antenna embedded into them. Data rate can be increased by increasing the bandwidth but increasing bandwidth is also a major constraint. Hence the goal was to double the transmission rate without increase in hardware or antenna of the portable device.

1.11 OBJECTIVE

The dissertation embodies the following objectives:

- To design a new Space Time Block Code, that doubles the Rate.
- To design a practically realizable decoder for the code above.

1.12 DISSERTATION OUTLINE

This dissertation is organised as follows:

Chapter 2 is dedicated to the literature survey. In this, work done by many earlier researchers has been presented and discussed the main ideas contained in them.

Chapter 3 outlines the theoretical background of the Space Time Block Code. The chapter further gives a brief description about the basic principles followed by STBC for its functionality and how different parameters associated with the Space Time Block Code.

Chapter 4 describes the various simulation and synthesis tools used to implement STBC decoder. This chapter also defines the flow of design for implementation.

Chapter 5 is presents the proposed code. It shows the decoding technique and various simulation results. This chapter also shows its hardware detail and its comparison.

Chapter 6 concludes this dissertation, summarizing the major results and offering suggestions for further work on this topic.

In the end, a list of references to this dissertation is given, without which this work could not have been possible.

2.1[12] S.M. Alamouti has described the diversity and orthogonal code

In October, 1998 Alamouti presented a paper, which utilizes the transmit diversity scheme and allows low effective bit error rate (BER). It is extremely difficult to reduce the effect of the multipath fading channel. In AWGN channel, reducing the bit error rate from 10^{-2} to 10^{-3} may require a change in signal to noise (SNR) only 1 or 2 dB higher signal to noise ratio. However, it may require about 10 dB improvements in SNR in multipath fading. The improvement in SNR cannot be achieved by increasing the transmit power or additional bandwidth, because it is contrary to the requirements of the next generation. The paper shows that this reduction in bit error rate can be achieved using diversity. This is one of the popular and simple techniques for MIMO technology. The encoding technique of symbols has the orthogonality property to a low complexity maximum likelihood decoding of the transmitted signals. This transmission scheme was presented for two transmit antenna and one receive antenna, which achieves full rate and full diversity of 2 over complex constellation symbols. It is also shown that it has dual diversity property i.e. it can achieve same full diversity of 2 with one transmit antenna and two receive antenna using maximal-ratio receiver combining (MRRC). This transmission scheme can be generalized to two transmit antenna and M receive antennas which again provides a full diversity of order of $2M$. This is the only scheme which achieves the full rate over complex constellation symbols. Hence it does not require any bandwidth expansion or any feedback from the receiver to the transmitter. Later, it is shown in many literatures that this is the only coding technique which has orthogonal codes at the transmitter over complex constellation symbols which is orthogonal and achieves full rate. The low complexity nature of the code has become the ideal candidate for practical implementation.

2.2 [13] V. Tarokh et. al. has described design criteria for space time codes

The paper has unveiled the new family of codes popularly known as space time block code (STBC). In this paper, new channel codes were developed for high data rate and reliability of transmission over multiple fading channels using multiple antennas. The channel codes are used to encode the data. These encoded data are split into N streams, which are transmitted using N transmit antennas simultaneously. A design criterion has been derived for designing the channel codes. The design criteria are derived for a channel which is slow fading and frequency non-selective. The design criterion quantifies the diversity gain by the minimum rank of the difference matrix and coding gain by the determinant of the difference matrix. The encoding and decoding complexity of the code is comparable with trellis codes. The received signals are the linear combinations of the N transmitted signals at each receiver antenna. The results are simulated for 2 and 3 bit/symbols over fast fading channels. The paper gave an insight to the operating bandwidth efficiencies which is twice to four times as high as those of systems using multiple transmit antennas. The decoding complexity of the codes is comparable to the codes used in practice on Gaussian channels. The author suggests that codes have systolic architecture which can be implemented in DSP and VLSI.

2.3 [17] V. Tarokh et. al. has described the new family of space time block codes and its limitations

This paper was an extension of [13], which has shown some constraint on the number of transmit antenna. The paper gave a name to the codes developed in [13] as Space Time Block Code (STBC). The codes must be orthogonal to each other for simple and linear decoding of the transmitted signals at the receiver end. The paper applies the theory of orthogonal designs to construct the space time block codes which is analogous to Alamouti's scheme. Radon has determined the set of dimensions for which an orthogonal design exists [19]. This paper utilizes the work of [19] and applies the theory of orthogonal to design the Space time block codes. The results shown in [19] are concerned with real square orthogonal matrices. The authors have extended the result of [19] to the non-square and complex orthogonal designs which has led to the generalization of orthogonal designs for arbitrary number of antennas. This paper generalizes the space time block code for more than two transmit antenna over real and complex constellation both. The paper studied the property of the complex orthogonal designs and proved that

generalization to more than two antennas is not possible over complex constellation. Therefore it states the scheme proposed by Alamouti [12] as a special case. The paper also developed the theory of complex generalized orthogonal designs. These designs have a linear and simple maximum likelihood decoding for arbitrary number of antenna. The designs provide full diversity and $\frac{1}{2}$ of the maximum possible rate over complex constellation. There are several other codes were developed as a special case for two, three and four transmit antenna which provide the $\frac{3}{4}$ of maximum possible rate.

2.4 [20] H. Jafarkhani has described the quasi orthogonal space time block code

In paper [17] it has been proved that design of space time block code is not possible for more than two transmit antennas over complex constellation which provides full diversity and full transmission rate. The author chose a different strategy and designed the space time block code having transmission rate one and provides a partial diversity. These new codes are called as quasi-orthogonal space time block code (QO-STBC). In [17] transmission codes were orthogonal to allow simple decoding which processes each symbol separately. In this paper the proposed work is not orthogonal instead the columns of transmission matrix are divided into groups and different groups are orthogonal to each other. Therefore at the receiver end of quasi orthogonal space time block code, the decoder cannot separate all the transmitted signals from each other. Hence, decoder processes pairs of transmitted symbols instead of single symbols. The paper compares the simulation result with full diversity orthogonal codes. It is shown that new codes having full transmission rate is important for very low SNR and high BER, while orthogonal designs having full diversity perform well at high SNR and low BER. The paper also states that the decoding complexity of QO-STBC is more than orthogonal designs in [17].

2.5 [21] N. Sharma et. al. has described the improved version of QO-STBC through constellation rotation.

The paper presents a solution to the problem occurred in [20]. This paper improves the performance of the quasi-orthogonal codes by introducing a novel rotation technique. The paper had achieved the higher code rate by constructing the quasi-orthogonal codes at the loss of diversity gain which affects the performance at higher SNR. The rotation technique presented in this paper had achieved the full diversity and full rate over the complex constellation. The simulation results show the improvements at higher SNR.

2.6 [22] J. C. Belore et. al. has described the concept of Golden number in space time block code

In this paper a concept of golden number is presented. Using this Golden number entails the golden code for 2 x 2 MIMO systems which achieves the full rate and full diversity. The minimum determinant of all previous code vanishes as the signal constellation is increased. This code has a non-vanishing determinant which helps to obtain the energy efficient codes.

2.7 [23] B. Cerato et. al. has described the architecture of the decoder for Golden Code

A VLSI implementation of decoder of for a MIMO system coded with Golden code [22] is presented in this literature. The proposed architecture is arranged such that it could achieve Maximum-likelihood (ML) decoding through sphere decoding algorithm. This architecture is flexible in terms of QAM modulation size. This paper presents two architectures: one achieves high decoding throughput and low overall decoding complexity and other is flexible implementation of dynamically adapt to modulation scheme retaining low complexity and high throughput feature.

2.8 [24] S. I. Park et. al. has described the architecture for reducing the hardware in decoder of IEEE 802.16e-2005 standard

This paper presents a new Rate-2 2 x 2 Space time block code with low complexity maximum likelihood detection. The paper minimizes the bit error rate at lower SNR by maximizing the coding gain. The code outperforms the conventional 2 x 2 space time block code for WiMax under low SNR regions. The paper also reduces the maximum likelihood detection complexity of the proposed space time block code. This reduction is significant compared to Matrix C defined in IEEE 802.16e-2005 standard.

CHAPTER

3

GENERALITIES OF SPACE TIME BLOCK CODE

3.1 INTRODUCTION

A space-time coding is a coding technique in which input bits are mapped to the transmitted symbols, designed for use with multiple antennas. Coding is performed in two domains: spatial and temporal. These two domains introduce a correlation between signals transmitted from various antennas at various time periods. The spatial-temporal correlation exploits the MIMO channel fading and minimizes transmission error at the receiver. Space time coding achieves transmit diversity and power gain over spatially uncoded systems without sacrificing bandwidth.

3.2 DESIGN CRITERIA

Certain guidelines are followed for designing of good codes, called as design criteria. A good code follows a design criterion which adds some concept of optimality to the code. This can be understood by an example. For a binary symmetric channel, the bit error rate of the system depends on the hamming distances of codeword pairs. It can be shown that a code with minimum Hamming distance d_{\min} can correct all the error patterns of weight less than or equal to $\lfloor (d_{\min} - 1)/2 \rfloor$, where $\lfloor x \rfloor$ is the largest integer less than or equal to x . Therefore, a good code design has a high minimum Hamming distance. The design criterion for such a code is to maximize the minimum possible Hamming distance among the codeword pairs. Similarly for an additive white Gaussian noise (AWGN) channel, a good design criterion is to maximize the minimum Euclidean distance among all possible codeword pairs. Some design criterion are discussed below which ensures lower complexity of decoder and maximum diversity gain and coding gain.

3.2.1 RANK AND DETERMINANT CRITERION

The rank and determinant criterion decides the diversity gain and coding gain respectively. Let us quantify the effects of mistaking two codewords with each other. Let us assume that we transmit a codeword C^1 given by a $T \times N$ matrix as

$$C^1 = \begin{pmatrix} C_{1,1}^1 & C_{1,2}^1 & \cdots & C_{1,N}^1 \\ C_{2,1}^1 & C_{2,2}^1 & \cdots & C_{2,N}^1 \\ \vdots & \vdots & \ddots & \vdots \\ C_{T,1}^1 & C_{T,2}^1 & \cdots & C_{T,N}^1 \end{pmatrix} \quad (3.1)$$

If decoder mistakenly decides that we have transmitted another codeword, for example C^2

$$C^2 = \begin{pmatrix} C_{1,1}^2 & C_{1,2}^2 & \cdots & C_{1,N}^2 \\ C_{2,1}^2 & C_{2,2}^2 & \cdots & C_{2,N}^2 \\ \vdots & \vdots & \ddots & \vdots \\ C_{T,1}^2 & C_{T,2}^2 & \cdots & C_{T,N}^2 \end{pmatrix} \quad (3.2)$$

The pairwise error probability is denoted as $P(C^1 \rightarrow C^2)$ for the transmitted codeword C^1 and detecting it as C^2 . When the codebook contains I code words, the probability of error is upper bounded by

$$P(\text{error} | C^1 \text{ is sent}) \leq \sum_{i=2}^I P(C^1 \rightarrow C^i) \quad (3.3)$$

Pairwise error probability is calculated assuming a fixed known channel H . At the end of derivation pairwise error probability it remains to Maximize $\|(C^2 - C^1) \cdot H\|_F^2$ to reduce the conditional pair wise error probability. Let us define the error (difference) matrix $D(C^1, C^2) = C^2 - C^1$. Hence, the error matrix $D(C^i, C^j) = C^j - C^i$ has to be full rank for all $i \neq j$ in order to obtain full diversity NM .

The pairwise error probability can also be written in terms of eigen values of a matrix

$$A(C^1, C^2) = D(C^1, C^2)^H \cdot D(C^1, C^2) = (C^2 - C^1)^H \cdot (C^2 - C^1) \quad (3.4)$$

Hence to obtain high coding gain the minimum determinant of (3.4) among all $i \neq j$ has to be large. This criterion is called as determinant criteria.

3.2.2 TRACE CRITERION

Trace criterion maximizes the coding gain. The minimum trace of $A(C^1, C^2) = D(C^1, C^2)^H \cdot D(C^1, C^2)$ among all $i \neq j$ has to be large to obtain high coding gain.

3.2.3 MAXIMUM MUTUAL INFORMATION CRITERION

The goal of this criterion maximizes the mutual information between transmitted and received signals. This design criterion is beneficial if one wants to maximize the throughput spatial multiplexing gain which in turn maximizes the throughput. The code should not be limited by the capacity of the MIMO channel. Therefore, for the designing of best code mutual information between input and output should be equal to capacity of the original channel.

3.3 SPACE TIME BLOCK CODE (STBC)

Space Time Block Codes are used to transmit the information over a multiple antenna wireless communication system. The goal in designing the Space Time Block Code is to achieve maximum diversity, the maximum coding gain and highest possible throughput. In the design of space time block code, the complexity of decoder is very important. All wireless communication devices have a limited available power through battery. The area of the portable device is also an important constraint; hence to improve the battery life, low complexity decoding is very crucial.

3.3.1 ALAMOUTI CODE

Alamouti's code is first space time block code to provide the full diversity for systems with two transmit diversity [12]. Let us assume an M -ary modulation scheme is used to generate the symbols for Alamouti's encoder. The first b bits are modulated to generate the symbol, where $b = \log_2 M$. the constellation may be any real and complex constellation. Then the transmitter picks a block of $2b$ bits to generate the two modulated symbols x_1 and x_2 in each coding operation.

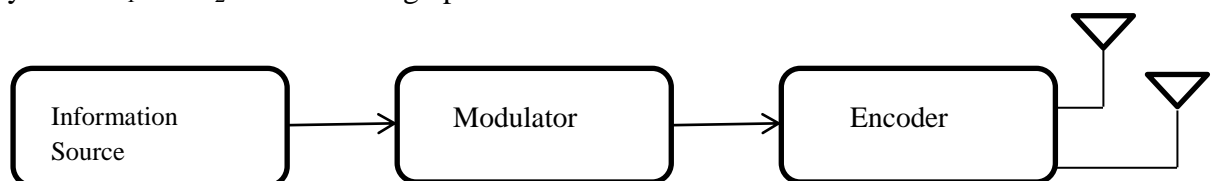

Figure 3.1: A block diagram of the Alamouti space time encoder

These symbols are then mapped to the transmit antenna. At first time slot, the transmitter sends s_1 from antenna one and s_2 from antenna two. Then at time two, it transmits $-s_2^*$ from antenna one and s_1^* from antenna two. Therefore, the transmitted code matrix is given by

$$C = \begin{bmatrix} s_1 & s_2 \\ -s_2^* & s_1^* \end{bmatrix} \quad (3.5)$$

The key feature of the Alamouti code matrix is that the transmit sequences from the two transmit antennas are orthogonal, since the inner product of the two columns of the matrix is zero i.e. $s_1 s_2^* - s_2^* s_1 = 0$

The code matrix has the following property

$$\begin{aligned} S.S^H &= \begin{bmatrix} |s_1|^2 + |s_2|^2 & 0 \\ 0 & |s_1|^2 + |s_2|^2 \end{bmatrix} \\ &= (|s_1|^2 + |s_2|^2)I_2 \end{aligned} \quad (3.6)$$

where I_2 is a 2 x 2 identity matrix.

The orthogonality property of Alamouti code helps in low complexity decoding. Alamouti code provides full diversity. To check it we need to calculate the rank of the all possible difference matrices $D(C, C')$ and show that it is equal to two for every $C' \neq C$. let us consider a different codeword with a different pair of symbols (s'_1, s'_2) .

$$C' = \begin{bmatrix} s'_1 & s'_2 \\ -s'^*_2 & s'^*_1 \end{bmatrix} \quad (3.7)$$

The difference matrix can be calculated as

$$D(C, C') = \begin{bmatrix} s'_1 - s_1 & s'_2 - s_2 \\ s_2^* - s'^*_2 & s_1^* - s'^*_1 \end{bmatrix} \quad (3.8)$$

The determinant of the equation (8) is given as

$$\det[D(C, C')] = |s'_1 - s_1|^2 + |s'_2 - s_2|^2 \quad (3.9)$$

The equation (3.9) is zero if and only if $s'_1 = s_1$ and $s'_2 = s_2$. Hence, it proves that difference matrix $D(C, C')$ is always full rank when $C' \neq C$. This has proved that Alamouti satisfies determinant criterion.

Let us assume that one receive antenna is used at the receiver. Let us assume that fading channel coefficients from transmit antenna one and two to the receive antenna are h_1 and h_2 respectively. The block diagram of receiver for the Alamouti transmission scheme is shown in figure 3.2.

At the receiver end, the decoder receives signals over two consecutive symbol period, denoted by r_1 and r_2 for time one and two respectively such that,

$$r_1 = h_1 s_1 + h_2 s_2 + n_1 \quad (3.10)$$

$$r_2 = -h_1 s_2^* + h_2 s_1^* + n_2 \quad (3.11)$$

Where n_1 and n_2 is additive white Gaussian noise samples with zero mean having power spectral density of $N_0/2$ per dimension.

The receiver of Alamouti scheme uses a coherent detection technique, where the fading channel coefficients are known to decoder. The decoder will use them as channel state information (CSI). A maximum likelihood decoder minimizes the decision metric

$$\begin{aligned} & d^2(r_1, h_1 \hat{s}_1 + h_2 \hat{s}_2) + d^2(r_2, -h_1 \hat{s}_2^* + h_2 \hat{s}_1^*) \\ &= |r_1 - h_1 \hat{s}_1 - h_2 \hat{s}_2|^2 + |r_2 + h_1 \hat{s}_2^* - h_2 \hat{s}_1^*|^2 \end{aligned} \quad (3.12)$$

Over all possible values of \hat{s}_1 and \hat{s}_2 . Substituting the values of r_1 and r_2 from equation (3.10) and (3.11) into (3.12), the maximum likelihood decoding can be represented as

$$(\hat{s}_1, \hat{s}_2) = \arg \min (|h_1|^2 + |h_2|^2 - 1)(|\hat{s}_1|^2 + |\hat{s}_2|^2) + d^2(\acute{s}_1, \hat{s}_1) + d^2(\acute{s}_2, \hat{s}_2) \quad (3.13)$$

Where \acute{s}_1 and \acute{s}_2 are two decision statics constructed by combining the received signals with channel state information. The decision statics are given by

$$\begin{aligned} \acute{s}_1 &= h_1^* r_1 + h_2 r_2^* \\ \acute{s}_2 &= h_2^* r_1 + h_1 r_2^* \end{aligned} \quad (3.14)$$

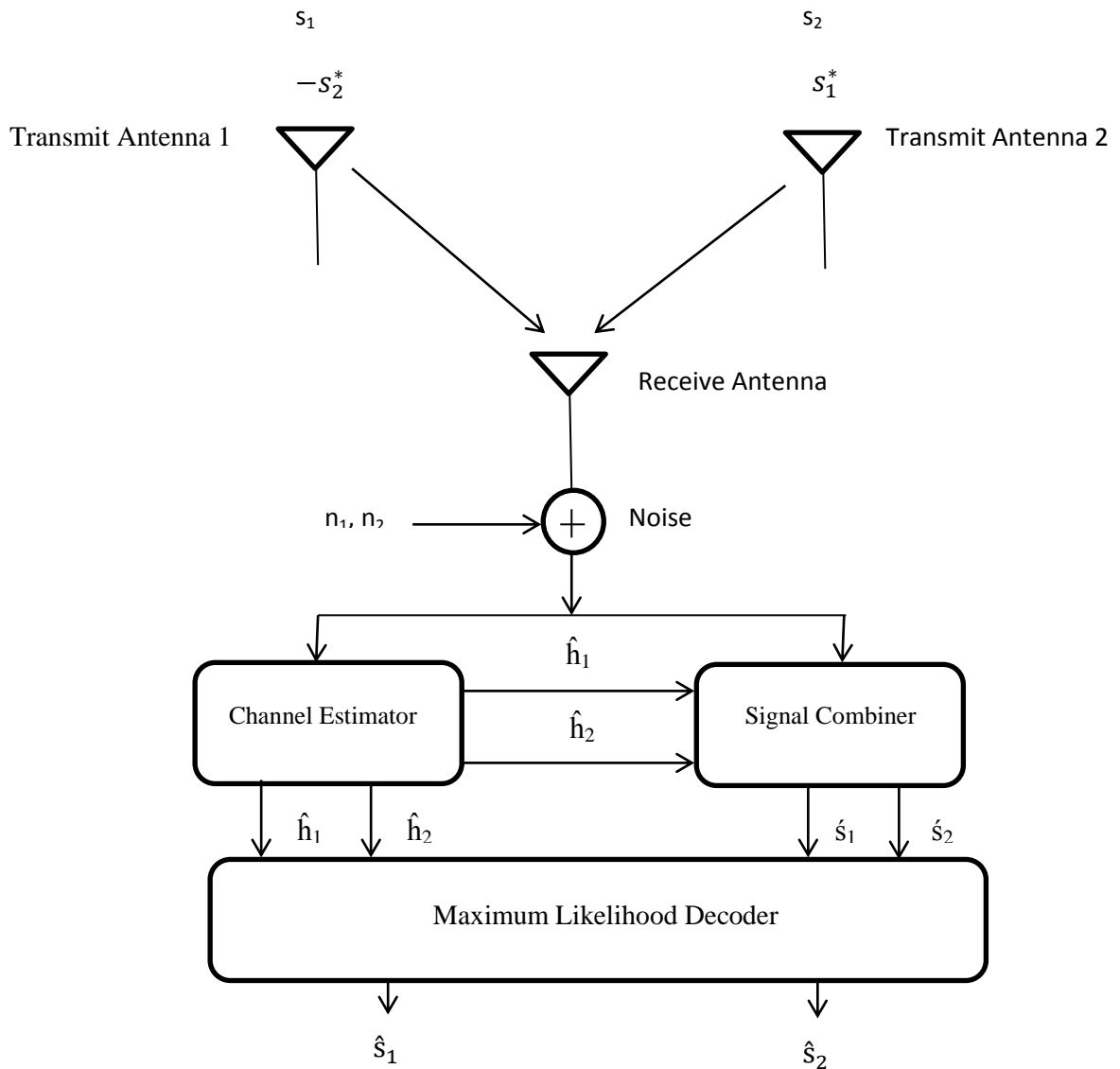

Figure 3.2: Receiver for the Alamouti scheme

Again substituting the values of r_1 and r_2 from equation (3.10) and (3.11) into (3.14), the decision statistics can be written as,

$$\begin{aligned}\hat{s}_1 &= (|h_1|^2 + |h_2|^2)s_1 + h_1^*n_1 + h_2n_2^* \\ \hat{s}_2 &= (|h_1|^2 + |h_2|^2)s_2 - h_1n_2^* + h_2^*n_1\end{aligned}\quad (3.15)$$

For a given channel realization h_1 and h_2 , the decision statistics $\hat{s}_i, i=1, 2$, is only a function of $x_i, i=1, 2$. Thus, the maximum likelihood decoding rule (3.13) can be separated into two independent decoding rules for x_1 and x_2 , given by

$$\hat{s}_1 = \arg \min (|h_1|^2 + |h_2|^2 - 1)|\hat{s}_1|^2 + d^2(\acute{s}_1, \hat{s}_1) \quad (3.16)$$

And

$$\hat{s}_2 = \arg \min (|h_1|^2 + |h_2|^2 - 1)|\hat{s}_2|^2 + d^2(\acute{s}_2, \hat{s}_2) \quad (3.17)$$

respectively. For a given signal constellation, if all the signal the term $(|h_1|^2 + |h_2|^2 - 1)|\hat{s}_i|^2$, $i = 1, 2$, are constant for all signal points, hence for a given the channel coefficients the above term can be ignored. Therefore, the decision rules in (3.16) and (3.17) can be further simplified to

$$\begin{aligned} \hat{s}_1 &= \arg \min d^2(\acute{s}_1, \hat{s}_1) \\ \hat{s}_2 &= \arg \min d^2(\acute{s}_2, \hat{s}_2) \end{aligned} \quad (3.18)$$

The performance of the Alamouti code with one receive antenna over Rayleigh fading channel is shown in figure 3.3. Figure shows the SNR versus symbol error probability plot using QPSK constellation. As it can be noticed, the performance of Alamouti code is much better than the uncoded system for the same constellation. In Alamouti scheme two transmit antenna and in uncoded system one transmit antenna is used. There is an improvement of 11dB at a symbol error rate of 10^{-3} , if Alamouti scheme is used. Alamouti scheme provides diversity gain which increases the SNR gap for higher SNR values. As Alamouti provides full diversity i.e. 2, hence we can deduce that error rate decreases inversely with γ^2 , where γ is the received SNR.

For M receive antenna the block diagram for the decoder is shown in figure 2.4. Maximum ratio combining has to be used for the maximum likelihood decoding while more than one antenna is installed at the receiver. The Alamouti code has dual diversity i.e. it has same diversity of two for the system with one transmit antenna and two receive antennas using maximum ratio combining.

The Alamouti code provides two important properties.

- Simple decoding: Each symbol is decoded separately using linear processing reduces complexity of the decoder.
- Maximum diversity: The code satisfies the rank criterion and therefore provides the maximum possible diversity.

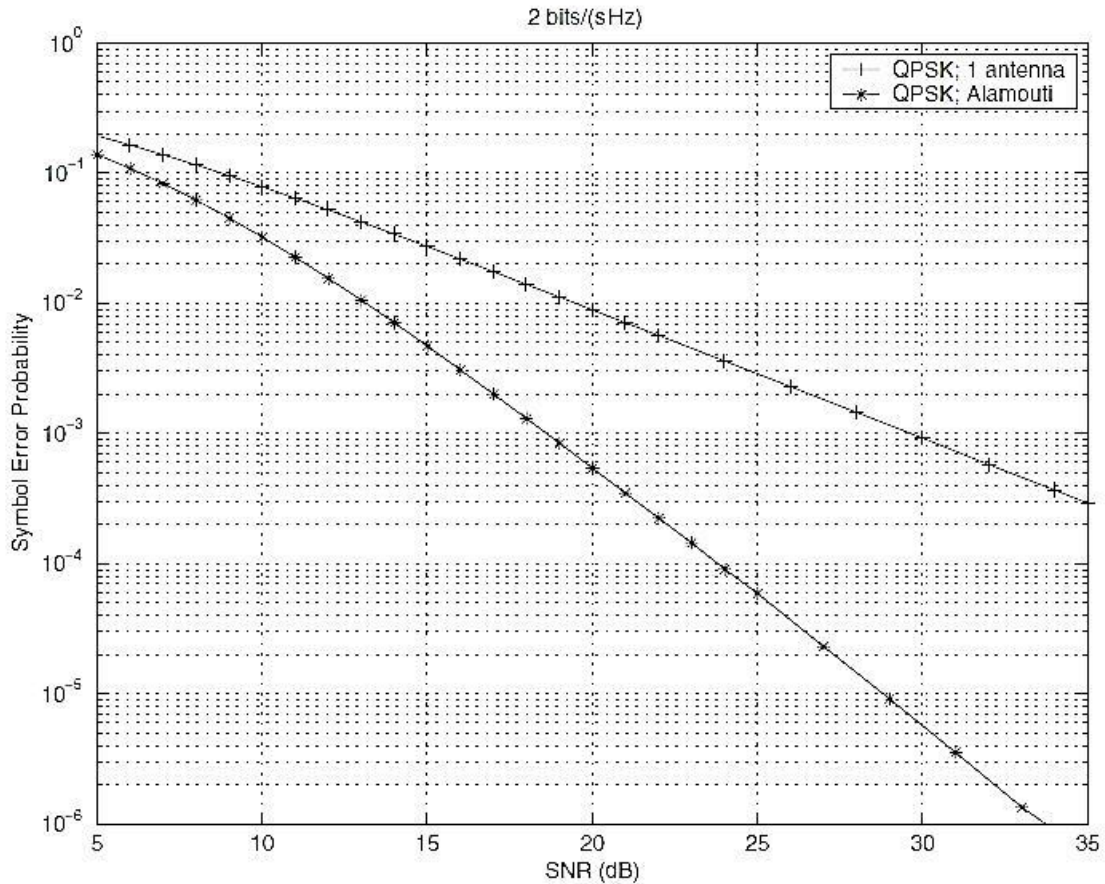

Figure 3.3: Performance of the Alamouti code

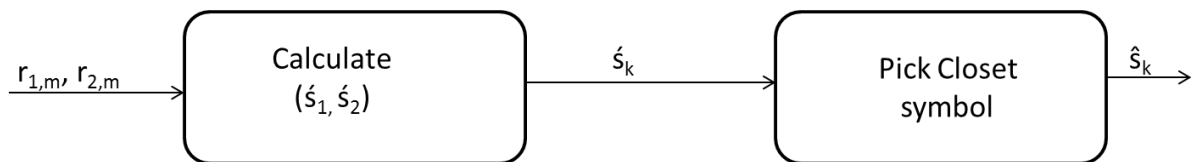

Figure 3.4: Decoder block diagram for Alamouti with MRC

These are most desirable property for any Space time block code that has to be achieved. Alamouti has achieved it for two transmit antenna. An important question is: Is it possible to design similar codes for a greater number of transmit antennas?

3.4 STBC FOR MORE THAN TWO TRANSMIT ANTENNA

The Alamouti scheme, designed for two transmit antenna, achieves full diversity with a very simple maximum likelihood decoding algorithm. The orthogonality property of the scheme is key features between the sequences generated by the two transmit antennas. By applying the theory of orthogonal design, these scheme can be designed for an arbitrary

number of transmit antenna. These generalized schemes are known as *space time block codes* (STBCs) [17]. The space-time block codes perform a very simple maximum-likelihood decoding algorithm, based only on linear processing of the received signals and achieve the full transmit diversity [17].

3.4.1 SPACE-TIME BLOCK ENCODER

A STBC encoder structure is shown in figure 3.5. Generally, a space time block code is defined by a matrix C having dimension of $N \times T$. where N represents the number of transmit antenna and T represents the time period or transmission of one block of coded symbols.

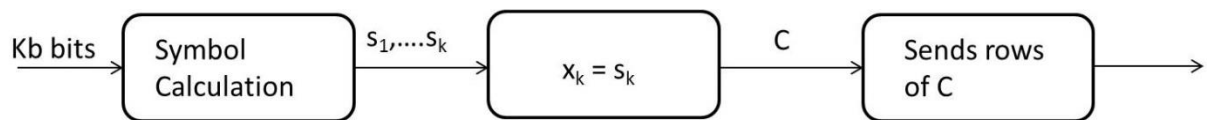

Figure 3.5: Block diagram of STBC Encoder

A group of b bits of information signals are selected to get the k modulated signal if there are 2^b signal constellation points. At each encoding operation, a block of kb information bits is mapped. The space time block encoder generates N parallel using k modulated signals s_1, s_2, \dots, s_k , where each group of m bits selects a constellation signal. All N generated signal having a length of T according to transmission matrix C . These sequences are transmitted through N transmit antennas simultaneously in T time periods. In other words, from each antenna T space time symbols are transmitted for each block of k input symbols.

The ratio between the number of symbols the encoder takes as its input and the number of space time coded symbols transmitted from each antenna is called as *rate* of the space time block code.

$$R = k/T \quad (3.19)$$

The spectral efficiency of the space time block code is given by

$$\eta = \frac{r_b}{B} = \frac{r_s b R}{r_s} = \frac{kb}{T} \text{ bits/sec/Hz} \quad (3.20)$$

Where r_b and r_s are the bit and symbol rate, respectively, and B is the bandwidth.

The linear combinations of k modulated symbols s_1, s_2, \dots, s_k and their conjugate $s_1^*, s_2^*, \dots, s_k^*$ constructs the elements of the transmission matrix C . A full diversity of the transmission matrix is constructed based on orthogonal designs such that [17]

$$C \cdot C^H = c(|s_1|^2 + |s_2|^2 + \dots + |s_k|^2)I_N \quad (3.21)$$

Where c is a constant, C^H is the Hermitian of C and I_N is an $N \times N$ identity matrix. At time j , the i^{th} row of C is transmitted through N transmit antenna. The j^{th} column of matrix is transmitted from an antenna in T time period. In other words, the element of C in i^{th} row and j^{th} column $s_{i,j}$, $i = 1, 2, \dots, N, j = 1, 2, \dots, T$, represents the signal transmitted from the antenna i at time j .

In [17], it has been shown that the rate of space time block code is less than or equal to one, $R \leq 1$. For a full rate i.e. $R = 1$, bandwidth expansion is not required, while the code with rate $R < 1$ requires a bandwidth expansion of $1/R$.

The orthogonal designs are applied to construct space-time block codes. The rows of the transmission matrix C are orthogonal to each other i.e. in each block, the signal sequences from any two transmit antennas are orthogonal. If we assume that $s_i = (s_{i,1}, s_{i,2}, \dots, s_{i,T})$ is the transmitted sequence from the i^{th} antenna, $i = 1, 2 \dots N$, then we have

$$s_i \cdot s_j = \sum_{t=1}^T s_{i,t} \cdot s_{j,t}^* = 0, \quad i \neq j, i, j \in \{1, 2 \dots, T\} \quad (3.22)$$

The orthogonality property of the code enables to achieve the transmit diversity. In addition, it also allows the receiver to decouple the signals transmitted from different antennas. Based on linear processing of received signals, a simple maximum likelihood is achieved.

3.4.2 STBC FOR REAL SIGNAL CONSTELLATION

The signal constellation points used in modulation can be real and complex. Based on this signal constellation points, the space time block codes can be classified into space-time block codes with real signals and space time block code with complex signals. If an $N \times T$ real transmission matrix C with variables s_1, s_2, \dots, s_k satisfies

$$C \cdot C^T = c(|s_1|^2 + |s_2|^2 + \dots + |s_k|^2)I_N \quad (3.23)$$

The space time block code provides full rate transmit diversity of N with a code rate of k/T . A square transmission matrix C is considered for designing of space time block code. A full diversity and full rate $R = 1$ space time block code with $N \times N$ square transmission matrix C exists for any arbitrary real constellation if and only if the number of transmit antennas $N = 2, 4, \text{ or } 8$ [17]. The transmission matrices are given by

$$C_2 = \begin{bmatrix} s_1 & s_2 \\ s_2 & -s_1 \end{bmatrix} \quad (3.24)$$

$$C_4 = \begin{bmatrix} s_1 & s_2 & s_3 & s_4 \\ s_2 & -s_1 & s_4 & -s_3 \\ s_3 & -s_4 & -s_1 & s_2 \\ s_4 & s_3 & -s_2 & -s_1 \end{bmatrix} \quad (3.25)$$

$$C_8 = \begin{bmatrix} s_1 & s_2 & s_3 & s_4 & s_5 & s_6 & s_7 & s_8 \\ s_2 & -s_1 & s_4 & -s_3 & s_6 & -s_5 & -s_8 & s_7 \\ s_3 & -s_4 & -s_1 & s_2 & -s_7 & -s_8 & s_5 & s_6 \\ s_4 & s_3 & -s_2 & -s_1 & -s_8 & s_7 & -s_6 & s_5 \\ s_5 & -s_6 & s_7 & s_8 & -s_1 & s_2 & -s_3 & -s_4 \\ s_6 & s_5 & s_8 & -s_7 & -s_2 & -s_1 & s_4 & -s_3 \\ s_7 & s_8 & -s_5 & s_6 & s_3 & -s_4 & -s_1 & -s_2 \\ s_8 & -s_7 & -s_6 & -s_5 & s_4 & s_3 & s_2 & -s_1 \end{bmatrix} \quad (3.26)$$

Equation (3.24), (3.25), and (3.26) are transmission matrices for $N = 2, 4, \text{ and } 8$ transmit antennas respectively.

A full rate $R = 1$ code is a desirable transmission scheme for any number of transmit antennas. To achieve full rate, the square transmission matrices must have both the number of transmit antennas N and the number of time period T has to be equal to the message block length k . for example, four transmit antenna and four time period are needed to transmit four message symbols. These square transmission matrices have orthogonal rows with entries $\pm s_1, \pm s_2, \dots, \pm s_k$. Let us take the case of four transmit antennas. The encoder generates the code sequence taking at its input the real modulated symbols s_1, s_2, s_3, s_4 . These encoded symbols are transmitted from antenna 1 through 4 respectively at time $t = 1$. Similarly, at time $t = 2$, the symbols from 2nd row of the transmission matrix are transmitted from antenna 1 through 4 respectively, and so on.

The space time block codes described above are full rate code. Full rate codes are bandwidth efficient as these codes does not require bandwidth expansion. There is a minimum value of T to achieve the full rate for N transmit antenna [17]. The minimum value of T is given by

$$\min(2^{4c+d}) \quad (3.27)$$

where the minimization is taken over the set

$$c, d \mid c \geq 0, 0 \leq d \leq 4, \text{ and } 8c + 2^d \geq N \quad (3.28)$$

For different value of N , the minimum value of T is given by

$$N = 2 \quad T = 2$$

$$N = 3 \quad T = 4$$

$$N = 4 \quad T = 4$$

$$N = 5 \quad T = 8$$

$$N = 6 \quad T = 8$$

$$N = 7 \quad T = 8$$

$$N = 8 \quad T = 8$$

Based on the values listed above, the full rate space time block codes are constructed. A full rate full diversity non-square space time block codes with sizes of 3, 5, 6 and 7 are designed based on the real orthogonal designs. These matrices are given as follows [17].

$$C_3 = \begin{bmatrix} s_1 & s_2 & s_3 \\ -s_2 & s_1 & -s_4 \\ -s_3 & s_4 & s_1 \\ -s_4 & -s_3 & s_2 \end{bmatrix} \quad (3.29)$$

$$C_5 = \begin{bmatrix} s_1 & s_2 & s_3 & s_4 & s_5 \\ -s_2 & s_1 & s_4 & -s_3 & s_6 \\ -s_3 & -s_4 & s_1 & s_2 & s_7 \\ -s_4 & s_3 & -s_2 & s_1 & s_8 \\ -s_5 & -s_6 & -s_7 & -s_8 & s_1 \\ -s_6 & s_5 & -s_8 & s_7 & -s_2 \\ -s_7 & s_8 & s_5 & -s_6 & -s_3 \\ -s_8 & -s_7 & s_6 & s_5 & -s_4 \end{bmatrix} \quad (3.30)$$

$$C_6 = \begin{bmatrix} s_1 & s_2 & s_3 & s_4 & s_5 & s_6 \\ -s_2 & s_1 & s_4 & -s_3 & s_6 & -s_5 \\ -s_3 & -s_4 & s_1 & s_2 & s_7 & s_8 \\ -s_4 & s_3 & -s_2 & s_1 & s_8 & -s_7 \\ -s_5 & -s_6 & -s_7 & -s_8 & s_1 & s_2 \\ -s_6 & s_5 & -s_8 & s_7 & -s_2 & s_1 \\ -s_7 & s_8 & s_5 & -s_6 & -s_3 & s_4 \\ -s_8 & -s_7 & s_6 & s_5 & -s_4 & -s_3 \end{bmatrix} \quad (3.31)$$

$$C_7 = \begin{bmatrix} s_1 & s_2 & s_3 & s_4 & s_5 & s_6 & s_7 \\ -s_2 & s_1 & s_4 & -s_3 & s_6 & -s_5 & -s_8 \\ -s_3 & -s_4 & s_1 & s_2 & s_7 & s_8 & -s_5 \\ -s_4 & s_3 & -s_2 & s_1 & s_8 & -s_7 & s_6 \\ -s_5 & -s_6 & -s_7 & -s_8 & s_1 & s_2 & s_3 \\ -s_6 & s_5 & -s_8 & s_7 & -s_2 & s_1 & -s_4 \\ -s_7 & s_8 & s_5 & -s_6 & -s_3 & s_4 & s_1 \\ -s_8 & -s_7 & s_6 & s_5 & -s_4 & -s_3 & s_2 \end{bmatrix} \quad (3.32)$$

To describe the above matrices, let us consider C_7 , the space time block code with seven transmit antenna. The space time block code encoder has eight symbols, s_1, s_2, \dots, s_8 , with real constellation, at its input. After the encoding operation, these coded symbols are transmitted through seven antennas in eight transmission period. For example, from the fourth antenna, signals $s_4, -s_3, s_2, s_1, -s_8, s_7, -s_6$ and s_5 are transmitted in first, second, third, etc., up to the eight transmission period, successively. It can be noticed that the number of symbols given at the input of the encoder is equal to the number of time period required to transmit these symbols. Hence, this scheme does not require any bandwidth expansion.

3.4.3 STBC FOR COMPLEX SIGNAL CONSTELLATION

If an $N \times T$ complex transmission matrix C_N with complex entries s_1, s_2, \dots, s_k and their conjugates $s_1^*, s_2^*, \dots, s_k^*$ satisfies

$$C \cdot C^H = c(|s_1|^2 + |s_2|^2 + \dots + |s_k|^2)I_N \quad (3.33)$$

Then the space time block code provides the full rate transmit diversity of N with a code rate of k/T .

For two transmit antenna, the Alamouti scheme can be a space time block code with complex signals. The transmission matrix is represented by

$$C = \begin{bmatrix} s_1 & s_2 \\ -s_2^* & s_1^* \end{bmatrix} \quad (3.34)$$

This scheme provides full diversity of 2 and the full rate of 1.

Alamouti scheme is the only scheme with an $N \times N$ complex transmission matrix to achieve the full rate [17]. For more than two transmit antenna, the full rate space time block code with complex constellation cannot be achieved. In that case, the code design goal is to construct high rate and full diversity complex transmission matrices with low

decoding complexity. In order to minimize the decoding delay the value of T minimized, similar to the real orthogonal design.

For any given number of antennas, a space time block code that can achieve a rate of $\frac{1}{2}$ for an arbitrary complex signal constellation. Complex transmission matrices of space time block code are given below for three and four antenna.

$$C_3^c = \begin{bmatrix} s_1 & s_2 & s_3 \\ -s_2 & s_1 & -s_4 \\ -s_3 & s_4 & s_1 \\ -s_4 & -s_3 & s_2 \\ s_1^* & s_2^* & s_3^* \\ -s_2^* & s_1^* & -s_4^* \\ -s_3^* & s_4^* & s_1^* \\ -s_4^* & -s_3^* & s_2^* \end{bmatrix} \quad (3.35)$$

$$C_4^c = \begin{bmatrix} s_1 & s_2 & s_3 & s_4 \\ -s_2 & s_1 & -s_4 & s_3 \\ -s_3 & s_4 & s_1 & -s_2 \\ -s_4 & -s_3 & s_2 & s_1 \\ s_1^* & s_2^* & s_3^* & s_4^* \\ -s_2^* & s_1^* & -s_4^* & s_3^* \\ -s_3^* & s_4^* & s_1^* & -s_2^* \\ -s_4^* & -s_3^* & s_2^* & s_1^* \end{bmatrix} \quad (3.36)$$

The matrices presented in equation (3.35) and (3.36) are orthogonal as the inner product of any two rows of above transmission matrices are zero. In equation (3.35), the transmission matrix C_3^c transmits four complex symbols in eight time period via three transmit antenna: hence the rate of the transmission is $\frac{1}{2}$. In equation (3.36), with matrix C_4^c four complex symbols are transmitted in eight time period through four, antennas again resulting in a transmission rate of $\frac{1}{2}$.

Using orthogonal design methodology it is difficult to obtain transmission rate more than $\frac{1}{2}$ for more than two antennas. However, a linear processing on symbols with complex constellation has managed to obtain a transmission rate of $\frac{3}{4}$ for more than two antennas. The space-time block code transmission matrices C_3^h and C_4^h are given below using complex generalized orthogonal designs with rate $\frac{3}{4}$ [17].

$$C_3^h = \begin{bmatrix} s_1 & -s_2^* & \frac{s_3^*}{\sqrt{2}} & \frac{s_3^*}{\sqrt{2}} \\ s_2 & s_1^* & \frac{s_3^*}{\sqrt{2}} & -\frac{s_3^*}{\sqrt{2}} \\ \frac{s_3}{\sqrt{2}} & \frac{s_3}{\sqrt{2}} & \frac{(-s_1 - s_1^* + s_2 - s_2^*)}{2} & \frac{(s_2 + s_2^* + s_1 - s_1^*)}{2} \end{bmatrix} \quad (3.37)$$

$$C_3^h = \begin{bmatrix} s_1 & -s_2^* & \frac{s_3^*}{\sqrt{2}} & \frac{s_3^*}{\sqrt{2}} \\ s_2 & s_1^* & \frac{s_3^*}{\sqrt{2}} & -\frac{s_3^*}{\sqrt{2}} \\ \frac{s_3}{\sqrt{2}} & \frac{s_3}{\sqrt{2}} & \frac{(-s_1 - s_1^* + s_2 - s_2^*)}{2} & \frac{(s_2 + s_2^* + s_1 - s_1^*)}{2} \\ \frac{s_3}{\sqrt{2}} & -\frac{s_3}{\sqrt{2}} & \frac{(-s_2 - s_2^* + s_1 - s_1^*)}{2} & \frac{-(s_1 + s_1^* + s_2 - s_2^*)}{2} \end{bmatrix} \quad (3.38)$$

For three transmit antenna, a space time block code with rate $\frac{3}{4}$ over complex signal constellation presented in [18] is given by

$$C_3^{h'} = \begin{bmatrix} s_1 & s_2^* & s_3^* & 0 \\ -s_2 & s_1^* & 0 & -s_3^* \\ -s_3 & 0 & s_1^* & s_2^* \end{bmatrix} \quad (3.39)$$

3.4.4 DECODING OF STBC

The square transmission matrix of the space time block code over real signal constellation has the first column as $[s_1, s_2, \dots, s_N]^T$. The all other column of the transmission matrix is permutations of the first column with different sign combinations. Let δ_t denote the permutations of the symbols from the first column to the p -th column. The row position of s_i in p -th column is shown by $\delta_t(i)$ and sign in the p -th column is denoted by $\text{sgn}_t(i)$.

Similar to Alamouti scheme, the decision statics of the maximum likelihood decoding for the transmitted signal s_i is given as

$$\hat{s}_i = \sum_{p=1}^N \sum_{j=1}^M \text{sgn}_t(i) \cdot r_t^j \cdot h_{j, \delta_t(i)}^* \quad (3.40)$$

Where $i = 1, 2, \dots, N$. The maximum likelihood minimizing metric is given as

$$\sum_{p=1}^N \sum_{j=1}^M |r_t^j - \sum_{i=1}^N h_{j,i} x_t^i|^2 \quad (3.41)$$

Due to orthogonality property of pairwise rows of the transmission matrix, it is equivalent to minimizing the joint decision metric

$$\sum_{i=1}^N \left[|\hat{s}_i - s_i|^2 + \left(\sum_{p=1}^N \sum_{j=1}^M |h_{j,t}|^2 - 1 \right) |x_i|^2 \right] \quad (3.42)$$

For a given received signal, the value of \hat{s}_i only depends on symbol s_i . Hence, minimizing equation (3.42) is further equivalent to minimizing individual decision metric

$$|\hat{s}_i - s_i|^2 + \left(\sum_{p=1}^N \sum_{j=1}^M |h_{j,t}|^2 - 1 \right) |x_i|^2 \quad (3.43)$$

Due to the orthogonality property of the transmission matrix, the transmitted signal s_i is independent of the other s_j , $j = 1, 2, \dots, N$, $j \neq i$. The decoding metric for each signal s_i is based on linear processing of its decision statistics \hat{s}_i , which allows a separate decoding for each transmitted signal.

Assuming that the receiver knows the perfect channel state information (CSI), the simulation results for the performance of space time block code on Rayleigh fading channels is shown in figure 6. The figure plots the symbols error rate of STBC with one receive antenna and number of transmit antenna is varied for comparison. The performance of an uncoded 8-PSK is also plotted for comparison.

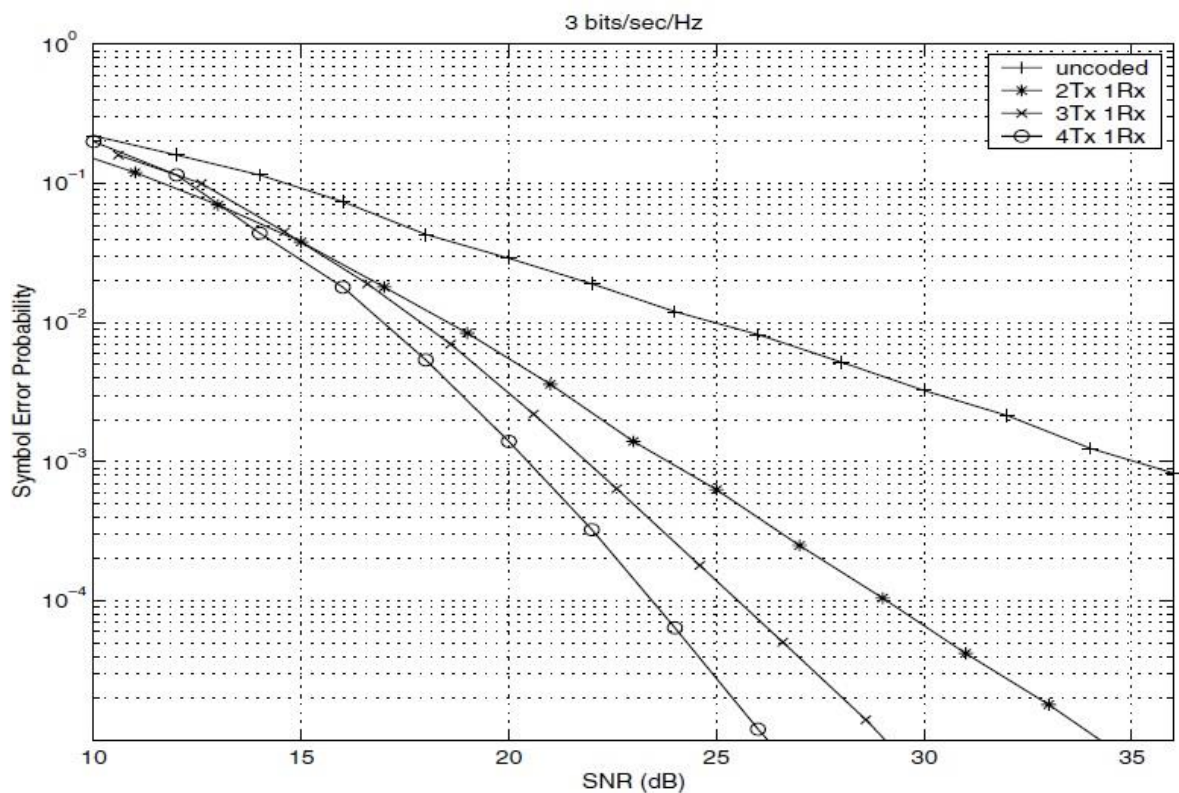

Figure 3.6: Performance of STBC on Rayleigh fading channel with one receive antenna

CHAPTER

4

FPGA IMPLEMENTATION

4.1 INTRODUCTION

FPGAs are semiconductor devices which has extremely useful property of field programming. Field programming means user or designer can reprogram it after its manufacturing. FPGA contains configurable logic blocks, input/output blocks and programmable interconnections. They also contain storing elements like flip flops or blocks of memory. The FPGA implementation of designs is performed to check their functionality on actual hardware. The cost of implementation and design cycle time of ASICs are large therefore the bigger designs are first checked on FPGA and if they give satisfactory results then their ASIC implementation is performed.

Tools required for implementation of Rate-2 decoder are:

- Xilinx ISE web pack 13.2 for design, synthesis and implementation
- ModelSim Simulator for simulation

4.2 SIMULATION TOOLS

ModelSim simulator is used to simulate the design written in VHDL language. ModelSim tool is used fast simulation of the design. ModelSim tool enables development and verification of the design completely. VHDL is a language is used for describing digital electronic system. Its full form is VHSIC Hardware Description Language. It arose out of the United States government's Very High Speed Integrated Circuit (VHSIC) program in 1980. It is used for the Gate level implementation of the circuits.

4.2.1 STRUCTURE OF VHDL CODE

Every VHDL design description consists of at least one Entity/ Architecture pair. (In VHDL, this combination of an entity and its corresponding architecture is sometimes referred to as a design entity)

In a large design, you will typically write many Entity/ Architecture pairs and connect them together to form a complete circuit

An entity declaration describes the circuits as it appears from the “outside” i.e. from the perspective of its input and output interface.

The second part of VHDL design description is the architecture declaration. Every entity in a VHDL design description must be bound with a corresponding architecture

Architecture describes the actual function or contents of the entity to which it is bound.

4.2.2 MODELING STYLES IN VHDL

The internal working of entity can be defined using different modeling styles inside architecture body. These are defined as follow:

- *Behavioral Style*: This description of the circuit will describe the circuit in term of its operation over time. In this type of modeling, the internal working of an entity can be implemented using- Process statements, Sequential Statements etc.
- *Data flow Style*: This gives the view of data as flowing through a design, from input to output. In this abstraction you describe your circuit in term of how data moves through system. At heart of most digital systems are gates, so in this we can describe how information is passed between different gates.
- *Structural Style*: In this we can describe the function how it composed of sub-modules. Each of sub-modules is an instance of some entity, and the ports of the instances are connected using signals.

4.3 SYNTHESIS TOOLS

Xilinx ISE design suite 13.2 is used for synthesis the implemented design.

4.3.1 XILINX ISE DESIGN SUITE 13.2

For this dissertation, we use Xilinx ISE design suite 13.2. We can generate synthesizable design in VHDL and Verilog languages. The Xilinx ISE design suite has several elements inbuilt such as counters, adders, multipliers, distributed ram, and block ram etc. These elements are fast and have low hardware requirements i.e. operation of these elements are fast and number of slices utilizes is less. Xilinx ISE design suite 13.2 enables the user to know about the area utilized by the synthesizable design, maximum clock frequency

supported by design, worst path delay in design etc. We can also analyse the RTL level design generated by the HDL design.

This XILINX release has been used for synthesis and implementation of our design. We can also download design or place and route the design on the desired FPGA.

4.4 FPGA DESIGN FLOW

This section describes the FPGA design flow. This is the entire process for design and implementation on FPGA board. The steps for design flow described below.

Step 1: Writing a Specification

This is the first step in FPGA implementation. Design specification allows design engineer to understand the entire design.

A specification should include the following information:

- An external block diagram showing how the chip fits into the system.
- An internal block diagram showing each major functional section.
- A description of the I/O pins including
 - Output drive capability
 - Input threshold level
 - Timing estimates including
 - Setup and hold times for input pins
 - Propagation times for output pins
 - Clock cycle time
- Estimated gate count
- Target power consumption
- Target price
- Design throughput

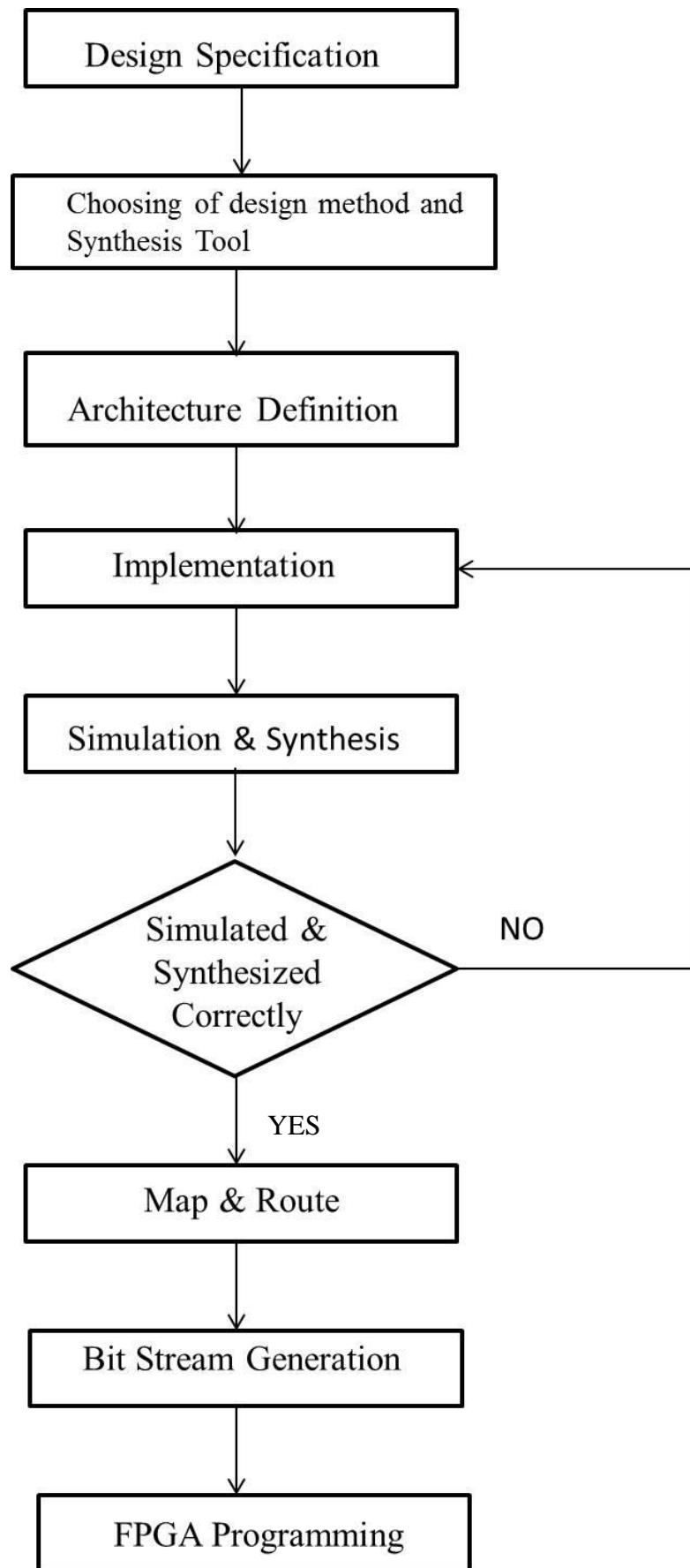

Figure 4.1: FPGA Design flow

Step 2: Choosing a Design Entry Method

Design method must be defined as per the designer choice. In design entry source files are created for representing the given design. The source file can be HDL file such as Verilog or VHDL, schematic file, embedded processor file, or EDIF file.

Step 3: Choosing a Synthesis Tool

FPGA implementation can only be performed for synthesized HDL code. To synthesize a synthesis tool must be defined since each tool has recommended or mandatory methods of designing hardware so that it can correctly perform synthesis. In this dissertation, Xilinx ISE design suite 13.2 is used as synthesis tool.

Step 4: Architecture Definition for design

It is very important to define architecture used for design. There are two design architecture used: Top-Down and Bottom-up. These approaches are required for large projects so that many designers can work together.

Step 5: Implementing of design

At this point, a source file is created for representing the design. The source file can be Verilog or VHDL. For this dissertation, we are using VHDL language.

Step 6: Simulation

After implementing the design, simulation is performed on simulators. All the small sections of the design are performed separately. After verifying the functionality of the small sections the whole design is simulated. In this dissertation, ModelSim is used for the simulation of the design.

Step 7: Synthesis

Synthesis is the general term that describes the process of transformation of the model of a design in HDL, from one level of Behavioral abstraction to a lower, more detailed level. This involves optimally translate the register transfer level (RTL) design into a gate level design that can be mapped to logic blocks in the FPGA. With reference to VHDL, synthesis is an automatic method of converting a higher level of abstraction to a lower level of abstraction. It is important here to note that not all features of VHDL can be synthesized; therefore, one must consult Xilinx Simulation and Synthesis Guide for a list

of synthesizable features. The netlist file has an extension .NGC and serves as input for the translate process. Figure shows the complete process of synthesis from HDL code to NGC file generation:

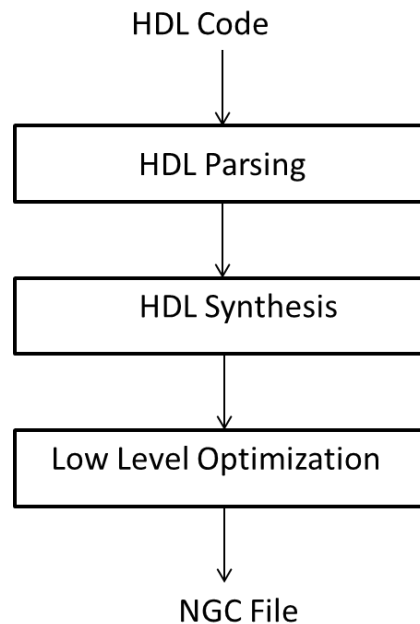

Figure 4.2: Flow of Synthesis Process

Besides generating NGC file XST generates RTL schematic, technology schematic and synthesis report. A synthesis report also created after synthesis. This report contains number of LUTs utilized, number of flip-flops and number of I/O bound used etc. this file also contains details of delay and timing estimations.

Step 8: Mapping

Map optimizes the gates and removes unused logic. This step also maps the designs logic resources and creates the sub-blocks. The sub-blocks are made so that they can fit into FPGA sub-blocks

Step 9: Place and route

Sub-blocks of map process are converted into logic blocks and connected in place and route step. This process takes NCD file as input and outputs the routed NCD file. Here placement and routing of blocks is done.

Step 10: Bit file generation

In this process bit file is generated for particular Xilinx device from the routed NCD file. The output bit file contains binary bits necessary to program the device. Sometimes this process is also called as bit stream generation. The generated bit file is used to program the FPGA device. Figure 4.3 shows the flow of generation of bit file.

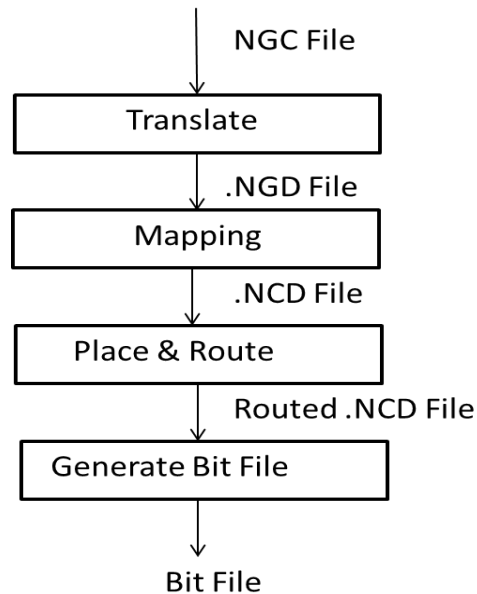

Figure 4.3: Different Files Generated in Implementation Process

CHAPTER

5

PROPOSED WORK

5.1 INTRODUCTION

The key feature of the space time block code is to have low complexity decoding complexity under multipath fading channel. All earlier codes were kept aside by STBC only due to its low decoding complexity which is a demand of today's wireless communication system.

The transmission rate of the wireless communication is also a challenge for today's researchers. Many codes were presented since the evolution of Space time block code improving different parameters [18], [20], [21] except increasing rate of the code. A concept of Golden number has come into light which achieves rate two for 2 x 2 antenna systems [22]. Later this scheme was included in IEEE 802.22e-2005 WiMax standard. Further a new lower complexity rate two code was presented in [24]. This paper reduces the decoding complexity of [22]. As discussed earlier that work on higher rate is absent for 2x1 antenna system. So we propose a new code which doubles the transmission rate of the 2x1 antenna system.

5.2 PROPOSED CODE

We propose a new rate 2 code for 2x1 antenna with good BER performance as follows:

$$\mathbf{X}_{\text{new}} = \begin{bmatrix} S_1 + jS_2 + \acute{S}_3 + j\acute{S}_4 & jS_1 + S_2 + j\acute{S}_3 + \acute{S}_4 \\ jS_1^* - S_2^* + j\acute{S}_3^* - \acute{S}_4^* & S_1^* - jS_2^* + \acute{S}_3^* - j\acute{S}_4^* \end{bmatrix} \quad (5.1)$$

Where S is the symbol and \acute{S} is rotated symbol. Here a rotated symbol is used to achieve the maximum likelihood detection. The proposed code above transmits four symbols in two time slots. Hence, Rate of the code is $4/2 = 2$ from definition. Using equation (1.3) and \mathbf{X}_{new} , the received signal matrix is given as

$$Y = \sqrt{\frac{\rho}{2}} X_{new} \begin{bmatrix} h_1 \\ h_2 \end{bmatrix} + \begin{bmatrix} n_1 \\ n_2 \end{bmatrix} \quad (5.2)$$

The received signal can be rearranged as

$$Y = \sqrt{\frac{\rho}{2}} H_{new} \begin{bmatrix} S_1 \\ S_2 \\ \acute{S}_3 \\ \acute{S}_4 \end{bmatrix} + \begin{bmatrix} n_1 \\ n_2 \end{bmatrix} \quad (5.3)$$

Where H_{new} is channel matrix given as

$$H_{new} = \begin{bmatrix} h_1 + jh_2 & h_2 + jh_1 & h_1 + jh_2 & h_2 + jh_1 \\ h_2^* - jh_1^* & -h_1^* + jh_2^* & h_2^* - h_1^* & -h_1^* + jh_2^* \end{bmatrix} \quad (5.4)$$

At the receiver end, the received signal Y is multiplied by H_{new}^H . Then the ML metric can be computed as

$$(S_1, S_2, \acute{S}_3, \acute{S}_4) = \arg \min \left\| Y - \sqrt{\frac{\rho}{2}} \alpha S \right\|^2 \quad (5.5)$$

Where S is the vector combination of symbols and α is found when we multiply $H_{new}^H * H_{new}$.

$$\bar{H} = H_{new}^H * H_{new} = \begin{bmatrix} \alpha & 0 & \alpha & 0 \\ 0 & \alpha & 0 & \alpha \\ \alpha & 0 & \alpha & 0 \\ 0 & \alpha & 0 & \alpha \end{bmatrix} \quad (5.6)$$

Where $\alpha = 2(|h_1|^2 + |h_2|^2)$

From the design of the code, we can see that received signal Y (1), Y (3) and Y (2), Y (4) are same. Hence instead of multiplying with H_{new}^H we multiply with \tilde{H} , which reduces the complexity at the decoder.

$$\text{Where } \tilde{H} = \begin{bmatrix} h_1^* - jh_2^* & h_2 + jh_1 \\ h_2^* - jh_1^* & -h_1 - jh_2 \end{bmatrix} \quad (5.7)$$

The above proposed code is simulated on MATLAB 2007b. Different modulation scheme is compared below for 10^5 data generated randomly. Figure 1 shows the average bit error rate (BER) performance of the proposed code on Rayleigh fading channel.

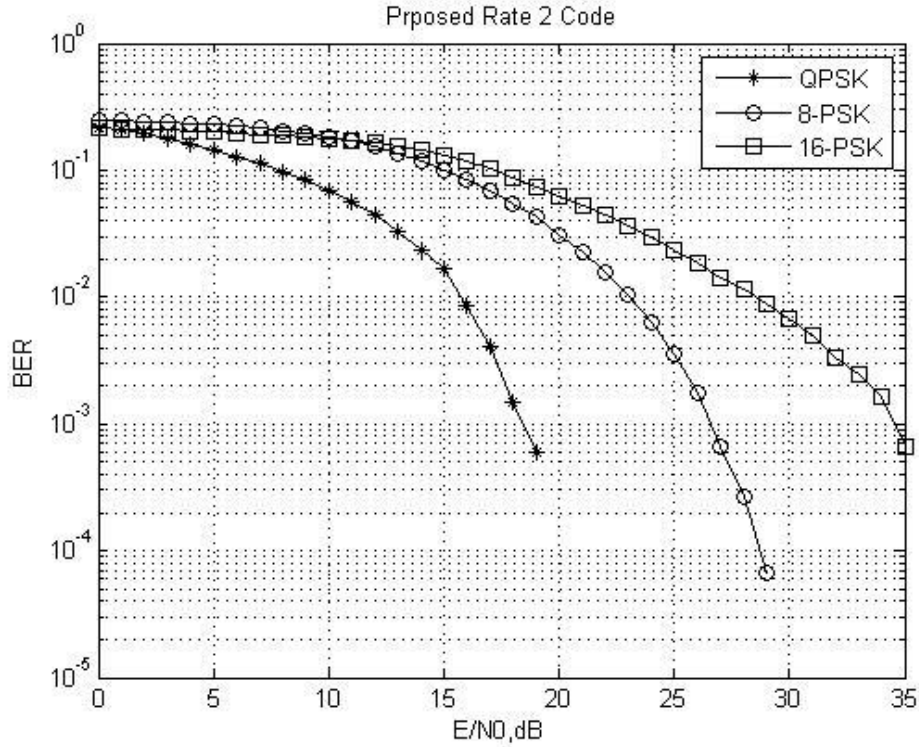

Figure 5.2: Performance of proposed Rate 2 code for 2x1 antenna

From the figure 5.1, one can deduce that SNR gain of the proposed code increases with modulation order for same BER. The proposed STBC obtains good performance under low SNR using QPSK modulation scheme. Since we are transmitting two symbols per time slot, hence it gives a data rate of 4 bits/s/Hz instead of 2 bits/s/Hz for QPSK modulation scheme.

5.3 HARDWARE DESIGN

A VLSI implementation of the proposed code has been carried out in Xilinx Spartan 3E using VHDL language. Implementation of decoder has been performed assuming channel state information is available at the receiver.

In the previous literatures the received signals are directly multiplied with H_{new}^H to decode the signals. If this method is used in this decoder then it will consume more area. So, we have used equation (5.7) to separate the signal, which reduces the number of multipliers and adders by a factor 2. A VHDL code was developed for its decoder and analysed using ModelSim simulator.

Architecture of rate-2 decoder is shown in figure (5.2). During the first clock cycle first two channel coefficient arrive at the decoder along with the received signal. These signals gets multiplied and added. The added signal is compared from the vector of array. The array is the outcome of different combination of symbols. After comparison minimum value is found and decoded symbol is selected from the vector of symbols and first and third symbols is gets detected. This same operation takes place during second clock cycle with different pair of the channel coefficients to detect second and fourth signal using same received signal.

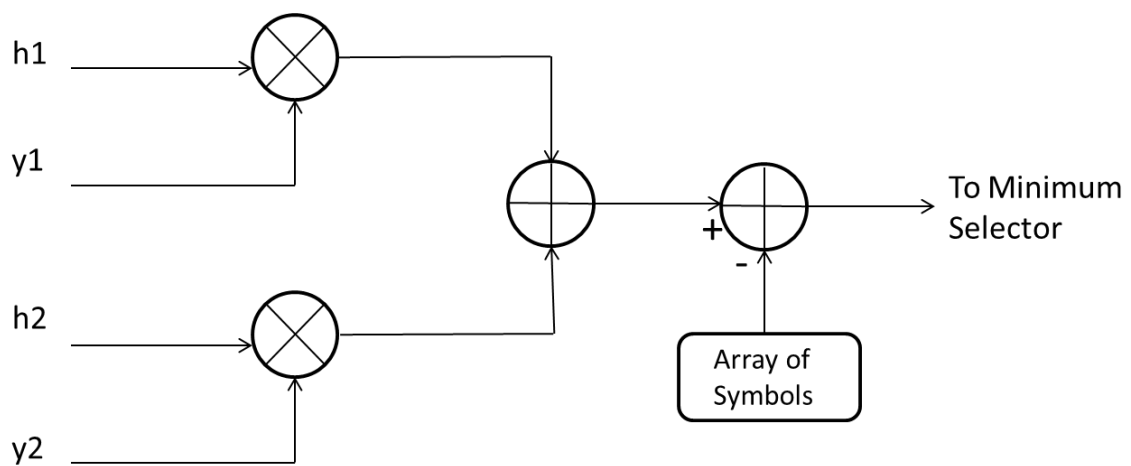

Figure 5.2: Architecture of Novel Rate 2 Decoder

The proposed architecture decodes two symbols in one clock cycle. The time taken by the decoder is same as that of the Alamouti decoder.

5.4 SIMULATION, FPGA IMPLEMENTATION & RESULTS

The top level RTL of the proposed rate-2 decoder is shown in figure 5.3. According to equation (5.7), four channel coefficients are inputs along with the received signal y_1 & y_2 . A global clock is given at the input of the decoder. Four signals are taken as output.

The result of Behavior simulation using ModelSim simulator is shown in figure 5.4. Here, a clock signal 'clk' is used for synchronous operation of the decoder. The decoder works on the positive edge of clock signal.

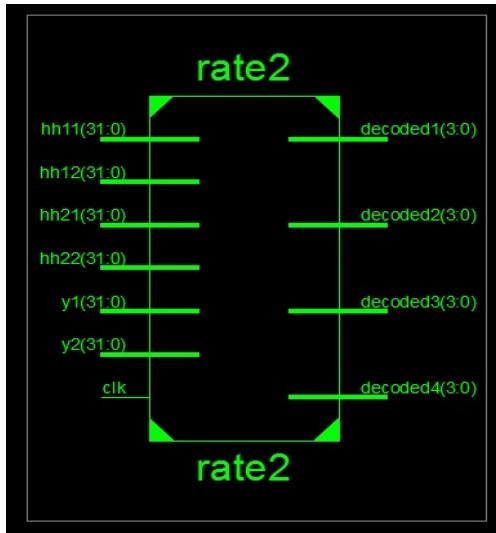

Figure 5.3: Top Level RTL of Proposed Architecture

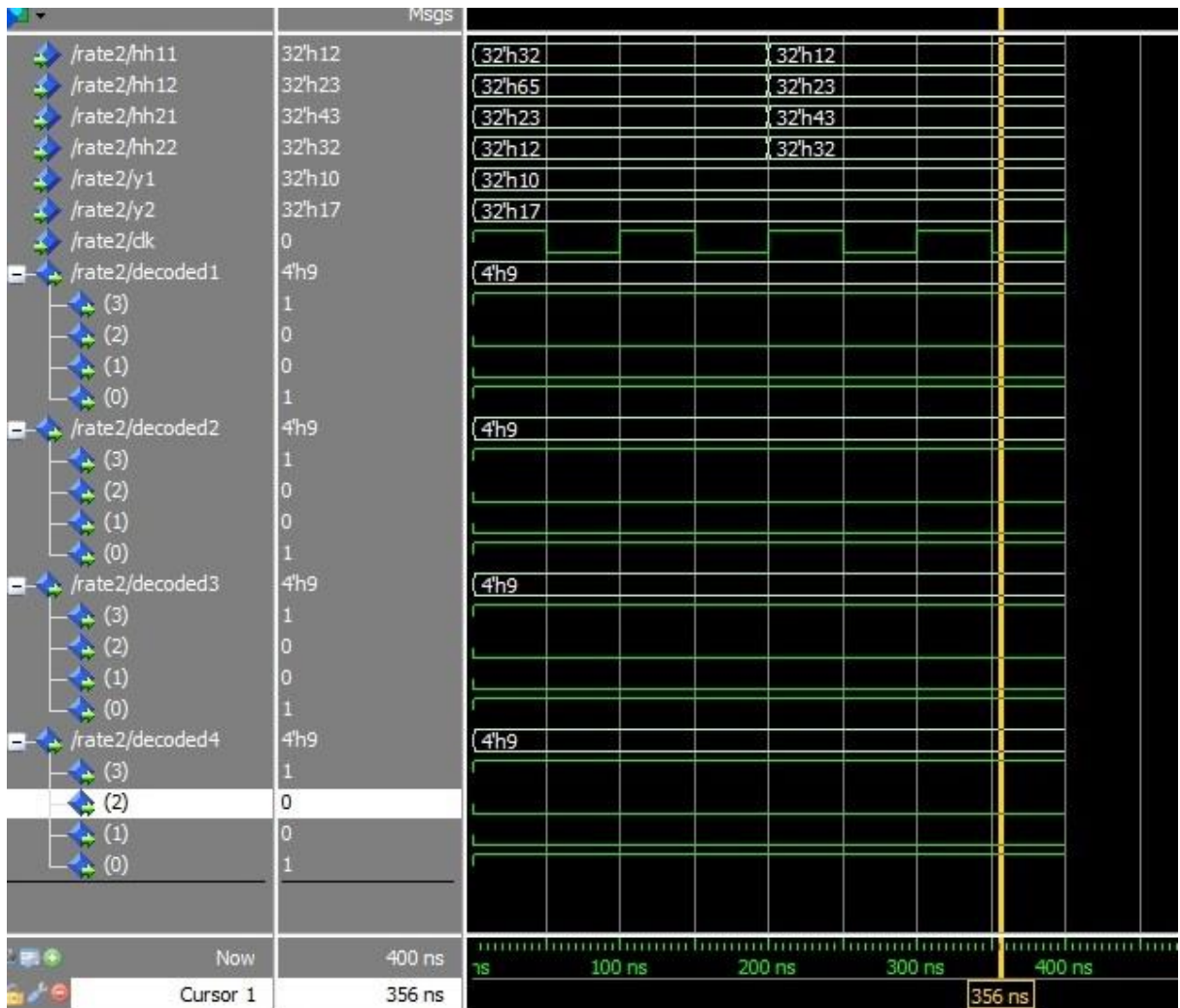

Figure 5.4: Behavioral Simulation of Proposed Decoder

Area of an FPGA board depends on the number of bits taken for the analysis of the system. Hence, instead of taking synthesis report of Xilinx, we have taken advanced HDL synthesis report of the hardware to compare different decoders. Total delay is 150.039ns. This delay is required to decode two symbols.

Table 5.1: Hardware Comparison of different decoders

Hardware\Decoder	Alamouti	QOSTBC	Rate 2 2x2	Proposed Rate 2
2-to-1 Multiplexer	8	32	8	32
Adder/Subtractor	2	13	5	4
Multiplier	2	27	6	2

From the table 5.1, the proposed code takes lesser number of adder and multiplier than Rate 2 code for 2x2 [24]. Extra 24 2:1 multiplexer takes lesser hardware than 1 adder and 4 multipliers. Hence the proposed code is practically realizable.

The expanded view of register transfer level (RTL) schematic is shown partially in figure (5.5). Entire RTL schematic is shown partially in figure (5.6).

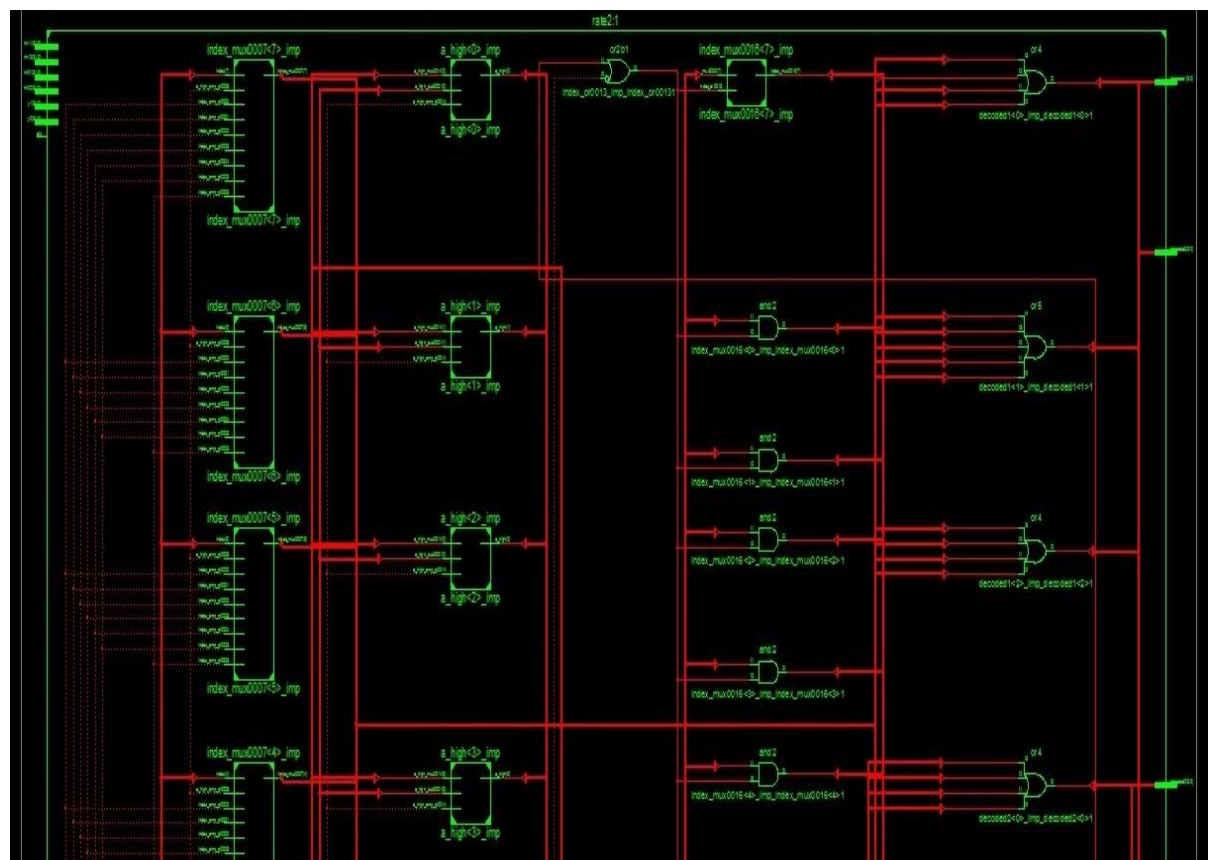

Figure 5.5: Expanded view of partial RTL Schematic

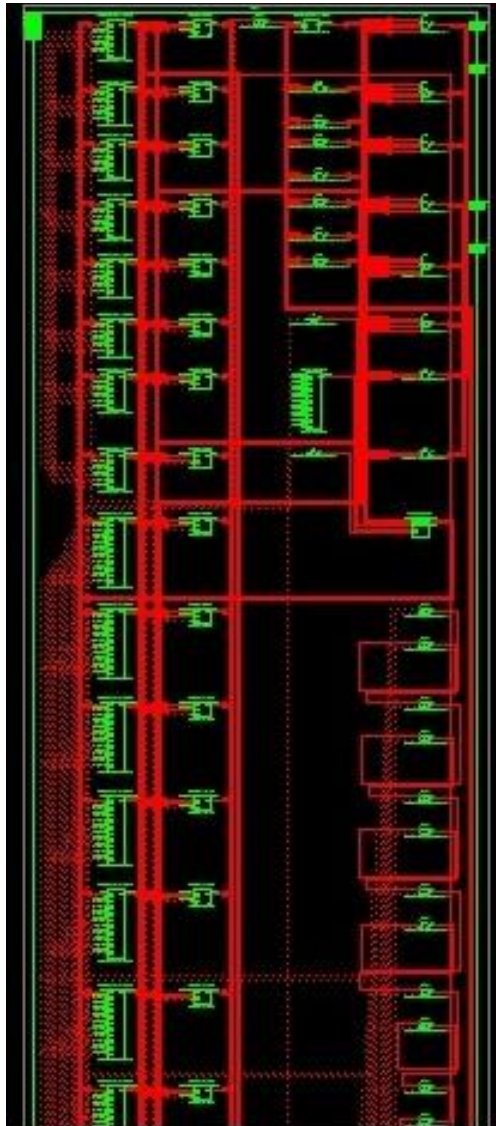

Figure 5.6: RTL Schematic

CHAPTER

6

CONCLUSION & FUTURE SCOPE

6.1 CONCLUSION

All portable devices have a constraint of area; on the contrary, high rate of data transmission is today's necessity. Portable devices have only one antenna embedded into them. Data rate can be increased by increasing the bandwidth but increasing bandwidth is also a major constraint. Hence the goal was to double the transmission rate without increase in hardware or antenna of the portable device.

In this thesis we presented a new space time block code for 2 x 1 antenna which doubles the transmission rate. We achieve our objective by developing rate-2 space time block code for two transmit antenna and one receive antenna without a significant sacrifice in the complexity of decoder. The proposed code developed and verified using MATLAB 2007b. While verification 10^5 data were generated randomly and transmitted through Rayleigh channel perturbed by noise. Simulations result shows that the proposed Rate-2 space time block code obtains good performance under low SNR using QPSK modulation scheme. Since we are transmitting two symbols per time slot, hence it gives a data rate of 4 bits/s/Hz instead of 2 bits/s/Hz.

In order to check the practicability of the decoder, we implemented the decoder of proposed Rate-2 space time block code on Xilinx Spartan 3E FPGA board using VHDL language. The advanced HDL synthesis report shows that proposed Rate-2 STBC decoder utilizes same number of multiplier and two more adders than Alamouti decoder for 2 x 1 antenna.

If this technology is implemented practically on portable devices then this code doubles the data rate or we can say it conserves half of bandwidth requirements after a small change in its decoder hardware.

6.2 FUTURE SCOPE

The performance of Space Time Block Code depends on the complexity of the decoder; meanwhile demand of high transmission rate is today's necessity. Considering the facts above the future scope of this work includes the following:

- The work can be extended for higher transmission rate
- The decoder of the code can be further optimized for n -PSK scheme.

LIST OF PUBLICATIONS

Paper “A Novel Rate 2 Space Time Block Code for 2x1 Antenna & implementation of its decoder in FPGA” has been communicated with Taylor & Francis: International Journal of Electronics Letters, 2014 with Manuscript Number TETL-2014-0586.

REFERENCES

- [1] W. C. Y. Lee, wireless and cellular telecommunication, 3rd ed., McGraw Hill, 2006.
- [2] A Goldsmith, Wireless communication, Cambridge University Press, 2005.
- [3] D.Tse, and P. Viswanath, Fundamentals of wireless communication, Cambridge University Press, 2005.
- [4] C. E. Shannon, "A mathematical theory of communication", *Bell System Technical Journal*, vol. vol. 27, pp. 379.423 and 623.656, July and October 1948.
- [5] C. Berrou, A. Glavieux, and P. Thitimajshima, "Near Shannon limit error-correcting coding and decoding: Turbo-codes", *IEEE International Conference on Telecommunications*, vol. 2, Issue 23-26, pp. 1064-1070, May 1993.
- [6] D. J. C. MacKay and R. M. Neal, "Near Shannon limit performance of low density parity check codes," *Electronics Letters*, vol. 32, no. 18, pp. 1645-1646, Aug. 1996.
- [7] A. Ghosh, R. Ratasuk, B. Mondal, N. Mangalveshe, and T. Thomas, "LTE-advanced: Next-generation wireless broadband technology," *IEEE Wireless Communication*, vol. 17, pp. 10-22, June 2010.
- [8] E. Perahia, "IEEE 802.11n development: History, Process, and technology," *IEEE Communication Magazine*, vol. 46, pp. 48-55, July 2008.
- [9] B. Li, Y. Qin, C. low, and C. Gwee, "A survey on mobile WiMAX [wireless broadband access]", *IEEE Communication Magazine*, vol. 45, pp. 70-75, December 2007.
- [10] E. Telatar, "Capacity of Multi-Antenna Gaussian Channels," *European Transactions on Telecommunications*, vol. 10, pp. 585-589, November 1999.
- [11] G. J. Foschini, "Layered space-time architecture for wireless communication in a fading environment when using multiple antennas", *AT&T Bell Laboratories Technical Journal*, vol. 1, no. 2, pp. 41-59, 1996.
- [12] S.M. Alamouti, A simple transmit diversity technique for wireless communications, *IEEE J. Selected Area Comm.* 16, pp. 1451–1458, October 1998.

- [13] V. Tarokh, N. Seshadri, A.R. Calderbank, Space–time codes for high data rate wireless communication: performance criterion and code construction, *IEEE Trans. Inform. Theory* vol. 44, pp. 744–765, March 1998.
- [14] B. Vucetic, and J. Yuan, *Space-time coding*, John Wiley & Sons Ltd, 2003.
- [15] A. Wittenben, “The diversity gain of transmit diversity in wireless systems with Rayleigh fading,” in *Proc. IEEE ICC’94*, USA, vol. 2, pp. 1121-1125, 1994.
- [16] V. Tarokh, H. Jafarkhani, and A. R. Calderbank, “Space-time block coding for wireless communications: performance results,” *IEEE Journal on Selected Areas in Communications*, vol. 17, pp. 451-460, March 1999.
- [17] V. Tarokh, H. Jafarkhani, and A. Calderbank, “Space-time block codes from orthogonal designs,” *IEEE Transactions on Information Theory*, vol. 48, pp. 1456-1467, July 1999.
- [18] B. Hochwald, T. L. Marzetta and C. B. Papadias, “A transmitter diversity scheme for wideband CDMA systems based on space-time spreading”, *IEEE Journal on Selected Areas in Commun.*, vol. 19, no. 1, pp. 48–60, , Jan. 2001.
- [19] J. Radon, “Lineare scharen orthogonaler matrizen,” in *Abhandlungen aus dem Mathematischen Seminar der Hamburgischen Universit“at*, vol. I. pp. 1–14, 1922.
- [20] H. Jafarkhani, A quasi-orthogonal space–time block code, *IEEE Trans. Comm.* Vol. 49, issue, pp. 1–4, January 2001.
- [21] N. Sharma, C.B. Papadias, Improved quasi-orthogonal codes through constellation rotation, *IEEE Trans. Comm.* vol. 51, issue 3, pp. 332–335, March 2003.
- [22] J. C. Belore, G. Rekaya and E. Viterbo, “The Golden code: A 2x2 fullrate space-time code with onvanishing determinants,” *IEEETrans. On Inform. Theory*, vol. 51, no. 4, pp. 1432-1436, April 2005.
- [23] B. Cerato, G. Maserà, and E. Viterbo, “Decoding the Golden Code: A VLSI Design” *IEEE Transactions on Very Large Scale Integration (VLSI) Systems*, vol. 17, no. 1, pp. 156-160, January 2009.
- [24] S. I. Park, H. M. Kim, N. Hur, “A New Rate-2 2×2 STBC with Low Complexity ML Detection”, *IEEE conference on consumer electronics (ICCE)*, pp. 364-365, 2013.