

**PERFORMANCE EVALUATION OF MICROSTRIP  
PATCH ANTENNA WITH DIFFERENT DGS SHAPES AND  
SUBSTRATE MATERIALS**

*Thesis submitted towards the partial fulfilment of requirement for the award  
of degree of*

**MASTER OF ENGINEERING**

**In**

**WIRELESS COMMUNICATION**

*Submitted by*

**Jashan Preet Singh**

**Roll No: 801363014**

*Under the guidance of*

**Ankush Kansal**

**Assistant Professor, ECED**

**Thapar University, Patiala**



**ELECTRONICS AND COMMUNICATION ENGINEERING**

**DEPARTMENT**

**THAPAR UNIVERSITY**

**(Established under the section 3 of UGC Act, 1956)**

**PATIALA – 147004, PUNJAB, INDIA**

**July 2015**

## DECLARATION

I, **Jashan Preet Singh**, hereby declare that the work, which is being presented in the thesis entitled "**Performance Evaluation of Microstrip Patch Antenna with Different DGS Shapes and Substrate Materials**" by me in partial fulfilment of the requirements for the award of degree of Master of Engineering in Wireless Communication from Thapar University, Patiala, is an authentic record of my own work carried out under the supervision of **Mr. Ankush Kansal**, Assistant Professor, Electronics and Communication Engineering Department.

The matter presented in this thesis has not been submitted in any other University/Institute for the award of any other degree.

Date: 15/7/15

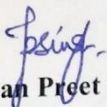
  
**Jashan Preet Singh**  
Roll no: 801363014

This is to certify that the above statement made by the student is correct to the best of my knowledge and belief.

Date:

  
**Mr. Ankush Kansal**  
Assistant Professor  
ECED  
Thapar University, Patiala

Countersigned by:

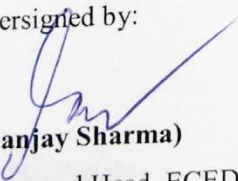
  
**(Dr. Sanjay Sharma)**  
Professor and Head, ECED  
Thapar University, Patiala

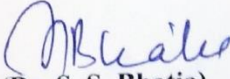
  
**(Dr. S. S. Bhatia)**  
Dean of Academic Affairs  
Thapar University, Patiala

## ACKNOWLEDGEMENT

---

I would never been able to finish my thesis without the supervision of faculty of my department, help from friends, and provision from my family.

I would like to utter my deepest thankfulness to my guide, **Mr. Ankush Kansal, Assistant Professor**, ECED, Thapar University, Patiala, for his excellent guidance, caring, patience, and providing me with an excellent atmosphere for doing research.

I would like to thank **Dr. Sanjay Sharma, Professor and Head**, ECED, Thapar University, Patiala, for granting us with sufficient facilities and infrastructure to carry our work.

I convey my sincere thanks to **Dr. Amit Kumar Kohli, Associate Professor** and **P.G. Coordinator**, ECED for his encouragement and cooperation.

I would like to acknowledge **Dr. Hemdutt Joshi, Assistant Professor** and **Program Coordinator (WC)**, ECED, Thapar University, Patiala, for being a source of inspiration for us during our research work.

My greatest thanks are to all who wished me success especially my parents. They were always supporting me and inspiring me. Above all I render my gratitude to the Almighty, who bestowed self-confidence, ability and strength in me to complete this work for not letting me down at the time of crisis and showing me the silver lining in the dark clouds. I do not find enough words which can express my feelings of thanks to my dear friends for their help, inspiration and moral support.

Place: TU, Patiala

Date: 15/7/15

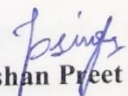
  
**Jashan Preet Singh**  
Roll No. 801363014

## ABSTRACT

---

In today's era, wireless communication system is the fastest growing segment in the communication research field. Rapid growth in the wireless technologies in the last decade have made antenna designing more challengeable. In present scenario, technology demands antenna which can operate on different wireless frequency bands and should have features like low cost, minimal weight, low profile that are capable of maintaining high performance over large frequency spectrum. Therefore microstrip patch antenna (MPA) with defected ground structure is the good candidate for these type of multiband applications having stable performance even at higher frequencies and provides large bandwidth. DGS is analysed in terms of its superior properties, which enables the designers to easily realize the various microwave applications which are impossible with standard techniques. Wireless local area network (WLAN) and Worldwide Interoperability for Microwave Access (WiMAX) have been widely used in mobile devices such as handheld computers and smart phones. These two techniques have been widely considered as a reliable, cost-effective, and high-speed data connectivity solution, also provides user mobility. This research work focuses on the designing, simulation and fabrication of microstrip patch antenna with defected ground structure for WiMAX/WLAN tri-band applications. The main advantage of multiband antenna has been achieved by varying the substrate material along with shapes of patch and ground defects. The major improvements had been achieved in gain, efficiency and return loss because of above mentioned variations in traditional MPA's. The proposed antennas have compact size with planer structure consisting of patch, microstrip feed line and a defected ground plane. The traditional antennas have been analysed and fabricated on the FR4 substrate but the antenna proposed in this thesis work has been fabricated on the ROGER RO3003 substrate due to various advantages. The analysis and designing have been optimized with the aid of CST Microwave Studio® version 2014. Further, simulation results of CST Microwave Studio® have been supported by the experimental results of fabricated proposed antennas.

In this research work two novel antenna designs have been proposed for tri-band applications. The first design have square shape metal strip patch enclosing a U-shape metal strip having curved shape ground plane with three square shape ground defects of different dimensions. The peak return losses obtained of this antenna in three

frequency bands are -19.33 dB at 2.4 GHz, -24.25 dB at 3.5 GHz and -39.5 dB at 5.45 GHz. The bandwidth obtained is 0.33 GHz (2.20-2.53 GHz), 1.15 GHz (3.09-4.24 GHz) and 0.86 GHz (5.03-5.89 GHz) respectively. The peak gains obtained in three operating frequency bands are 2.81 dBi, 2.65 dBi and 4.38 dBi respectively.

The second design antenna have Y-shaped metal strip enclosed by a circular shape metal strip and curved shape ground with three polygon defects of different shape and dimensions. The peak return losses obtained of this antenna are -20.41 dB at 2.45 GHz, -26.42 dB at 3.34GHz and -31.97 dB at 5.5GHz respectively. The bandwidth of three bands are 0.3GHz (2.27-2.57GHz), 1.17GHz (3.07-4.24GHz) and 1.302GHz (4.837-6.139GHz). The isotropic peak gains of three bands are 2.66 dBi, 2.58dBi and 4.5 dBi respectively.

**Keywords:** Microstrip patch antenna (MPA), Defected ground structure (DGS), Computer simulation technology (CST), WiMAX (Worldwide Interoperability Microwave Access), WLAN (Wireless Local Area Network).



1.2.4 Fifth Generation	3
1.3 WLAN (Wireless Local Area Network)	5
1.4 1.4 WiMAX (Worldwide Interoperability for Microwave Access)	6
1.5 Role of Antenna in the Wireless Communication	8
1.6 Microstrip Patch Antenna (MPA)	8
1.7 Feeding techniques of microstrip patch antenna	10
1.7.1 Microstrip Line Feed	10
1.7.2 Coaxial Probe Feed	11
1.7.3 Aperture Coupled Feed	12
1.7.4 Proximity Coupled Feed	12
1.8 Different type of materials for patch and substrate	14
1.9 Advantages and disadvantages of microstrip patch antenna	14
1.9.1 Advantages	15
1.9.2 Disadvantages	15
1.10 Defected Ground Structure (DGS)	15
1.11 Different Geometries of Defected Ground Structure	16
1.12 Working Principle of DGS	17
1.13 Applications of DGS	17
1.13.1 Slow-Wave Effect	17
1.13.2 Stop Band Effect	17
1.13.3 High Characteristics Impedance	17
1.14 Thesis Outline	18
<b>2. LITERATURE REVIEW</b>	<b>19-27</b>
2.1 Evolution of Mobile Communications	19

2.2 Microstrip Patch Antenna with various parameters	19
2.3 Microstrip Patch Antenna with Defected Ground Structure	22
2.4 Dual Band Antenna	24
2.5 Triple Band Antenna	25
2.6 Gaps	27
2.7 Objectives of Thesis	27
<b>3. MODELLING OF MPA WITH DGS</b>	<b>28-33</b>
3.1 Mathematical Model for Microstrip Patch Antenna	28
3.1.1 Transmission line model	28
3.1.2 Rectangular patch antenna	29
3.1.3 Circular patch antenna	30
3.2 Modelling Techniques of Defected Ground Structure	31
3.2.1 LC and RLC circuit modelling	32
3.2.2 $\pi$ Shaped equivalent circuits	32
<b>4. ANTENNA RESULTS &amp; DISCUSSION</b>	<b>34-56</b>
4.1 Methodology	34
4.2 Conventional Design for Triple Band Antenna with DGS	35
4.2.1 Antenna design	35
4.2.2 Return loss analysis of antenna	36
4.2.3 Gain of the conventional antenna	37
4.3 A Novel Microstrip Patch Antenna using Square Shaped Ground Defects for Wimax/WLAN Applications (Antenna 1)	38
4.3.1 Antenna Design	38
4.3.2 Return loss and Bandwidth of antenna	39

4.3.3 Efficiency of proposed antenna	40
4.3.4 VSWR of proposed antenna	40
4.3.5 Radiation pattern of antenna in H-plane	41
4.3.6 Radiation pattern of antenna in E-plane	42
4.3.7 Gain (dBi) of antenna	43
4.3.8 Directivity of antenna	43
4.3.9. Comparison of return loss for variable parameter	46
4.4 A Novel Design of Multiband DGS Based Microstrip Patch Antenna for WLAN/Wimax Applications (Antenna 2)	46
4.4.1 Antenna Design	46
4.4.2 Return loss and bandwidth of the proposed antenna	48
4.4.3 Efficiency of antenna	48
4.4.4 VSWR of proposed antenna	49
4.4.5 Radiation pattern of antenna in E-plane	49
4.4.6 Radiation pattern of antenna in H-plane	50
4.4.7 Gain of antenna	51
4.4.8 Directivity of antenna	52
4.4.9 Comparison of return loss for variable parameter	55
4.5 Comparison of Antenna 1 and Antenna 2	55
4.5.1 Comparison of gain	55
4.5.2 Comparison of Efficiency	56
4.5.3 Comparison of Side lobe level	56
<b>5. ANTENNA FABRICATION &amp; TESTING</b>	<b>57-61</b>
5.1 Antenna Fabrication Procedure	57

5.2 Fabricated Antenna Design	58
5.3 Antenna Testing using VNA	59
5.4 Comparison of Measured and Simulated Return Loss	60
<b>6. CONCLUSION &amp; FUTURE SCOPE</b>	
6.1 Conclusion	62
6.2 Future Scope	63
<b>REFERENCES</b>	<b>64-68</b>
<b>LIST OF PUBLICATION</b>	<b>69</b>

## LIST OF FIGURES

---

Figure No.	Description	Page No.
Fig. 1.1.	Structure of microstrip patch antenna	9
Fig. 1.2.	Side view of microstrip patch antenna	9
Fig. 1.3.	Patch antenna with microstrip feed line	10
Fig. 1.4.	Patch antenna with coaxial feed	11
Fig. 1.5.	Aperture coupled feed	12
Fig. 1.6.	Proximity coupled feed	13
Fig. 1.7.	Various DGS geometries	16
Fig. 1.8.	Equivalent circuit of DGS	17
Fig. 3.1.	Microstrip line	28
Fig. 3.2.	Electric field line	28
Fig. 3.3.	Circular microstrip patch antenna	30
Fig. 3.4.	LC parallel combination	31
Fig. 3.5.	LCR parallel combination	32
Fig. 3.6.	(a) $\pi$ Shaped equivalent structure (b) $\pi$ Shaped structure	33
Fig. 4.1.	(a) Front view of antenna (b) Back view of antenna	35
Fig. 4.2.	Return loss of conventional antenna	36
Fig. 4.3.	(a) Front view of antenna (b) Back view of antenna	38
Fig. 4.4.	Return loss of antenna	39
Fig. 4.5.	Efficiency of antenna	40
Fig. 4.6.	VSWR of antenna	41
Fig. 4.7.	Simulated H-plane radiation pattern of antenna	41
Fig. 4.8.	Simulated E-plane radiation pattern of antenna	42
Fig. 4.9.	Gain vs frequency plot of antenna	43
Fig. 4.10.	3D radiation pattern of antenna at 2.5 GHz	43
Fig. 4.11.	3D radiation pattern of antenna at 3.5 GHz	44
Fig. 4.12.	3D radiation pattern of antenna at 5.2 GHz	44
Fig. 4.13.	3D radiation pattern of antenna at 5.5 GHz	45
Fig. 4.14.	3D radiation pattern of antenna at 5.8 GHz	45
Fig. 4.15.	Comparison of return loss of antenna for variable parameters	46
Fig. 4.16.	(a) Front (patch) view (b) Back (ground) view of antenna	47

Fig. 4.17.	Simulated return loss vs frequency plot of antenna	48
Fig. 4.18.	Simulated total efficiency vs frequency plot of antenna	48
Fig. 4.19.	Simulated VSWR vs frequency antenna	49
Fig. 4.20.	Simulated E-plane radiation pattern of antenna	50
Fig. 4.21.	Simulated H-plane radiation pattern of antenna	51
Fig. 4.22.	Simulated gain vs frequency plot of antenna	51
Fig. 4.23.	3D radiation pattern of antenna at 2.5 GHz	52
Fig. 4.24.	3D radiation pattern of antenna at 3.5 GHz	53
Fig. 4.25.	3D radiation pattern of antenna at 5.2 GHz	53
Fig. 4.26.	3D radiation pattern of antenna at 5.5 GHz	54
Fig. 4.27.	3D radiation pattern of antenna at 5.8 GHz	54
Fig. 4.28.	Return loss of antenna after changing parameters	55
Fig. 4.29.	Comparison of gain of Antenna 1 and Antenna 2	55
Fig. 4.30.	Comparison of efficiency of Antenna 1 and Antenna 2	56
Fig. 4.31.	Comparison of side lobe level at $f=5.5\text{GHz}$ of Antenna 1 and Antenna 2	56
Fig. 5.1.	Generalized PCB fabrication process	58
Fig. 5.2.	Front (top) and back (bottom) view of negative of antenna design	58
Fig. 5.3.	The photograph of top and back view of the fabricated antenna	59
Fig. 5.4.	Photograph of VNA and antenna connection	59
Fig. 5.5.	Photograph of measured return loss of proposed antenna	60
Fig. 5.6.	Comparison of measured and simulated return loss of antenna	60

## **LIST OF TABLES**

---

Table No.	Description	Page No.
1.1.	Evolution of generations of wireless communication systems	4
1.2	Various specifications in the WLAN 802.11 family	6
1.3	Various specifications of WiMAX IEEE 802.16 family	7
1.4	Comparison of feeding techniques	13
1.5.	Patch antenna materials	14
1.6	Substrate materials	14
4.1	Parameters of conventional antenna	36
4.2	Peak gain of antenna in different frequency bands	37
4.3	Parameters of proposed Antenna 1	39
4.4	Parameters of proposed Antenna 2	47

## LIST OF ABBRIVATIONS

---

AMC	Adaptive Modulation and Coding
AMPS	Advanced Mobile Phone Systems
CAD	Computer Aided Design
CDMA	Code Division Multiple Access
CPW	Coplanar Waveguide
CST	Computer Simulation Technology
DGS	Defected Ground Structure
DSSS	Direct Sequence Spread Spectrum
EDGE	Enhanced Data Rate for GSM Evolution
FDMA	Frequency Division Multiple Access
FHSS	Frequency Hopping Spread Spectrum
GPRS	General Packet Radio Service
GPS	Global Positioning System
GSM	Global System for Mobile Communication
HARQ	Hybrid Automatic Request
HDTV	High Definition Television
HSDPA	High Speed Downlink Packet Access
HSUPA	High Speed Uplink Packet Access
ITU	International Telecommunication Union
IMT	International Mobile Telecommunication
LOS	Line of Sight
LTE	Long Term Evaluation
MPA	Microstrip Patch Antenna
MIMO	Multiple Input Multiple Output
MMS	Multimedia Messaging Service
OFDM	Orthogonal Frequency Division Multiplexing
SMA	SubMiniature version A
TDMA	Time Division Multiple Access
UMTS	Universal Mobile Telecommunication System
UWB	Ultra Wide Band
VNA	Vector Network Analyser

VSWR	Voltage Standing Wave Ratio
WiMAX	Worldwide Interoperability Microwave Access
WLAN	Wireless Local Area Network

## INTRODUCTION

---

*This chapter gives an overview of wireless communication system and evolution of wireless communication generations. The role of microstrip patch antenna along with its mathematical model and feeding technique has been also discussed. Need of microstrip patch antenna with defected ground structure for various applications has been explained with the working of DGS model.*

---

### 1.1 Overview

Today the wireless industry is fastest growing field in the corporate world. The demand of the wireless systems is increasing day by day as the need of far field communication is increasing with in the industry, defence and medical as well as in daily life of human beings [1]. Due to all these requirements the wireless industry is perceiving a volatile rise in the present era, with the demand of systems that are versatile and robust [2]. For the far field communication the electromagnetic spectrum is used. The electromagnetic spectrum is natural resource, it is fully utilized by the antenna systems. Basically the long distance far field wireless communication is carried out by the cellular systems [1]. The demand of the cellular system have increased exponentially in the last two decades, due to billions of subscribers that covers industry for its proper working to the human beings for their everyday life events [3]. In the wireless communication systems the communication is carried with the help of the radio transmitter and radio receiver.

### 1.2 Evolution of Wireless Communication System

At present the wireless communication is about to reaching the fifth generation (5G). As moving towards each next generation there are lots of improvements and new features are added to the wireless communication system [3]. The brief description of all the five generations is given below:

#### 1.2.1 First Generation

The first generation (1G) was introduced in the early 1980's. This generation was adjusted to transmit the voice signals by the analog communication standards that covers analog frequency modulation technology [3]. This generation is totally voice oriented technology that gives all the services with the aid of circuit switching. It

provides data rate of maximum 2.4 kbps. In this technology all the subscribers share the same frequency spectrum with the help of Frequency Division Multiple Access (FDMA) e.g. AMPS [2].

## **1.2.2 Second Generation**

### **1.2.2.1 2G Technology**

The second generation (2G) was introduced in the early 1990's. It was the improved version the first generation (1G). 2G works on digital signal transmission. This 2G is also for voice communication but with voice communication it also provides the SMS messaging service as a form of data transfer in text form. 2G is based on the GSM (Global System for Mobile Communication) standards. GSM standard is a combination of the Time Division Multiple Access (TDMA) and the Code Division Multiple Access (CDMA) i.e. slow frequency hopping with frequency shift keying for the voice modulation [1]. 2G GSM could convey not only voice, but also circuit-switched data at data rate up of 64- 14.4 Kbps .It overcomes all the limitations of the 1G that are security, harmful radiations and less capacity. It works on the 900 and 1800 MHz frequency bands.

### **1.2.2.2 2.5G General Packet Radio Service (GPRS)**

2.5G is the extension of 2G network. 2G network based on the circuit switched domain but the 2.5G (GPRS) is based packet switched domain. It provides data rate from 56- 384 Kbps. It provides the services like Multimedia Messaging Service (MMS), email, Wireless Application Protocol (WAP) and World Wide Web (WWW) access. It provides the data transfer service digitally [3].

### **1.2.2.3 2.75G Enhanced Data rates for GSM Evolution (EDGE)**

With the introduction of the 8PSK encoding system EDGE network has been evolved from the GPRS network. Enhanced GPRS (EGPRS), IMT-SC or EDGE are the backward compatible technologies that acts as the extension of GSM standard by providing the enhanced data transmission rates. EDGE technology is the base of 3G technology. It provides flexibility between circuit switched data and packet switched data [1].

## **1.2.3 Third Generation**

### **1.2.3.1 3G Technology**

The third generation (3G) was introduced in the 2000's. It was improved version of the 2G. It was introduced by International Telecommunication Union (ITU) with IMT 2000

mobile telephony standards to overcome the limitations and to add extra features to the 2G [1]. It provides the increased bandwidth, expedite growth and support more various applications. But to upkeep mobile multimedia applications, 3G had to transport packet-switched data with improved spectral efficiency, at greater speeds. Third generation supports various wireless applications e.g. mobile internet access, video telephony, video calling, MMS service, fixed wireless internet, mobile TV etc. [3]. It provides data rate of 2-14 Mbps.

#### **1.2.3.2 3.5G High-Speed Down Link Packet Access (HSDPA)**

3.5G is an extension of 3G networks. For the higher data rates it works on the UMTS-based 3G networks. It is a packet switched based data services provides data transmission rate of 8-10 Mbps in W-CDMA downlink. The implementation of HSDPA includes Hybrid Automatic Request (HARQ), MIMO, fast cell search and Adaptive Modulation and Coding (AMC) [5].

#### **1.2.3.3 3.75G High Speed Uplink Packet Access (HSUPA)**

HSUPA is a complementary technology of HSDPA. HSUPA provides the better experience of real time data transfer i.e. for the person to person data transfer. The real time applications are fast email service or person to person fast online games [3].

#### **1.2.4 Fourth Generation**

It was the succeeding of 3G technology. Fourth generation (4G) is the technologies for very high data rate mobile wireless communication system designed for the interactive TV and new data services through mobile network. It provides very high data rate of upto 100 Mbps [4], this is possible with aid of various techniques such as self-adaptive modulation, Orthogonal Frequency Division Multiplexing (OFDM), multiple carriers etc. [4]. It has very high packet switched data rate as compared to the 3G technology. 4G technology covers the Wireless Local Area Network (WLAN), Long Term Evolution (LTE) and also Worldwide interoperability of Microwave Access (WiMAX). WLAN (Wi-Fi) operates on the OFDM technique.

#### **1.2.5 Fifth Generation**

Fifth generation (5G) network is assumed as the perfection level of wireless mobile communication technology. Cable (Wire) network is nowadays become the memory of past. Now at present mobiles are not only a communication tool but also aid many other purposes of day to day life. 5G is enchanting a new touch and creating the life real mobile life. Actually at present 5G is under experiments, it is not available for the mass

market [5]. It will provide access to different wireless terminals at the same time with different technologies. 5G will provide HDTV on mobile with great clarity and without any interruption i.e. unwanted buffering. The enhanced performance of cognitive radio and cloud computing can be achieved through 5G [3].

**Table 1.1 Evolution of generations of the wireless communication system [3-5]**

Generation	Speed	Technology	Time-period	Features
1G	1- 2.4 kbps	AMPS	1980-1990	Used only for voice communication, no official requirements. Analog based protocols.
2G	14.4-64 kbps	TDMA, CDMA	1990-1998	First digital system, new service SMS is added with voice. Improved coverage and capacity. Allowing multiple users on a single channel through multiplexing.
2.5G	56-384 kbps	GPRS	1997-2000	Can be used in WAP, MMS etc. Packet switched domain technology is used.
2.75G	500 kbps	EDGE	1998-2000	Provided flexibility between the packet switched domain and circuit switched domain.
3G	2-8 Mbps	CDMA, UMTS, EDGE	2000-2004	Integrated high quality data, video and audio. First mobile based broadband. Multimedia messaging services (MMS) and internet on PDA's become possible through ITU's IMT-2000.

3.5G/3.75G	8-10 Mbps	UMTS/ WCDMA	2004- 2010	HSDPA: High Speed Downlink Packet Access includes MIMO, HARQ, and AMC etc. HSUPA: High Speed Uplink Packet Access provides high data rate for real time applications.
4G	14-100 Mbps	WLAN, LTE, WiMAX	At present	Wearable devices and provides dynamic information access. Portability increases and high definition streaming is possible through 4G. IP based protocols (LTE). ITU's IMT- Advanced with true mobile broadband.
5G	Probably in GHz	Not defined yet	Coming Soon	Currently not deployed. Very useful for the users that require very high data rate greater than the 4G.

In this thesis, work have been done on the microstrip patch antenna for the WiMAX/WLAN wireless applications as discussed.

### **1.3 WLAN (Wireless Local Area Network)**

WLAN uses microwave, radio and infrared transmission for the transmission of data from source to destination without cables. WLAN is actually Local Area Network without cables [6]. WLAN can be connected to existing lager internet network that provides it flexibility. IEEE 802.11 standard is assigned to WLAN [4]. A WLAN comprises of nodes and access points. A node may be computer or its peripheral device which has the WLAN card, a network adaptor and case with an antenna. The access points has the function to act as the receiver and transmitter between the nodes themselves. WLAN gained lots of popularity and its importance increases because of

increasing number of portable devices like laptop, tablets, smart phones and also provides easy installation [6].

In the implementation of WLAN the data transfer is carried out by using the following technologies:

- Direct Sequence Spread Spectrum (DSSS).
- Frequency hopping Spread Spectrum (FHSS).
- Infrared (IR).
- Orthogonal Frequency Division Multiplexing (OFDM)

**Table1.2 Various Specification in the WLAN 802.11 family [6].**

Parameters Standards ↓	Carrier Frequency	Multiple Access	Peak Data Rate	Services
802.11 a/g	2.4 GHz/5 GHz (ISM)	OFDM- TDMA	54 Mbps	High Data Rate
802.11 b	2.4 GHz (ISM)	DSSS	5.5 Mbps	Data
802.11 n	2.4 GHz/5 GHz (ISM)	OFDM- TDMA	248 Mbps	High Rate Data

#### **1.4 WiMAX (Worldwide Interoperability for Microwave Access)**

WiMAX (Worldwide Interoperability for Microwave Access) is a 4G wireless communication standard by ITU's IMT-Advanced [3]. The IEEE 802.16 standard is assigned to the WiMAX. With diversity of devices WiMAX gives broadband connectivity in almost all the places i.e. from a small city to a big country in the world. This standard provides a data transmission rate of 30 to 40 Mbps [7]. For fixed station subscribers WiMAX provides data rate up to 1Gbit/s. It also provides 5 data as well as telecommunication services and a source of internet connectivity to the portable devices which is a part of WiMAX business plan.

Operation of WiMAX: Non-line of sight operation of WiMAX is similar to WLAN service, where a small antenna of laptop or computer system is connected to the transmitting tower. In this mode, lower operating frequency range is from 2 GHz to 11

GHz i.e. used by WiMAX. Actually the lower-wavelength transmitted waves are easily able to bend or diffract around the physical obstructions [5].

**Table 1.3. Various Specifications of WiMAX IEEE 802.16 family [7].**

Parameter Standards ↓	Frequency	Channel bandwidth	Data Rate	Channel Condition	Applications & Features
802.16a	2-11 GHz	1.5-20 MHz	75 Mbps	Non- LOS	Backhaul for hotspot, Residential broadband access, PC with outside antenna,
802.16	10-66 GHz	20-28 MHz	32- 134 Mbps	LOS	Indoor Broadband access, Arial, antenna, built antennas with external box.
802.16e	2-6 GHz	1.5-20 MHz	15 Mbps	Non- LOS	Portable access consumers, Always best connected. PC card.

Line of sight (LOS) service is also available in WiMAX, in which there is a fixed dish antenna pointing directly at the WiMAX tower straight from the top of the roof or pole. LOS connection is stable and stronger, so it's easy to send a bulk of data with lesser inaccuracies. LOS communications use higher frequencies i.e. up to 66 GHz, because at higher frequencies more bandwidth is obtained with less interference [7].

The above explained WiMAX and WLAN standards have been widely functional in the mobile devices or portable devices such as laptops, tablets, smartphones etc. These two have gained popularity because it provides very high-speed data, reliable and cost effective with the mobility of the subscriber. With the rapid development in the field of wireless communication the antenna designing for the various wireless applications

become complicated, because there is requirement of wide multiband antennas with simple, small and rugged structure which can be fabricated with ease.

### **1.5 Role of Antenna in the Wireless Communication**

There are lots essential components that comprises the wireless network without them the network is not possible. The antenna is the most important component for the wireless networking. Antenna is required both at transmitter as well as receiver side. An antenna acts as the transition amongst the RF front-end circuitry and the propagation and radiation of electromagnetic (EM) waves in the free space [8].

An antenna is a metallic device that may be a rod, wire, plate i.e. conductor of many shapes that carries an alternating or pulsing current. An antenna acts as a transducer which converts the electrical current signal into the electromagnetic wave or vice-versa [9]. Antenna is used in the systems, including electronic warfare (EW) systems for the transmission and reception of the signals from the source to the destination in the form of the electromagnetic wave signal. According to the IEEE standards the definitions of antenna or aerial is defined as a means for radiating or receiving radio waves [10].

There are different kinds of antennas available in the market for the different applications as per requirement. Out of these antennas the microstrip patch antenna or planner patch antenna has gained its popularity in the market because of their low weight, low cost, low profile and easy integratability into arrays or with microwave integrated circuits [8]. These microstrip patch antennas also provides the wave polarization diversity.

### **1.6 Microstrip Patch Antenna (MPA)**

A microstrip patch antenna is generally comprises of a dielectric substrate sandwiched between a radiating metallic patch on the top and a metallic ground plane on the back i.e. other side as shown in the Fig. 1.1 [9]. The radiating patch is primarily made of the conducting material such as gold or copper as per requirement and can be of any possible. To facilitate the analysis and design of antenna the front patch is commonly of regular shapes e.g. triangle, circle, rectangle, square, ellipse, many more. The feed lines and the radiating patch are usually photo etched the front side of the dielectric substrate [10].

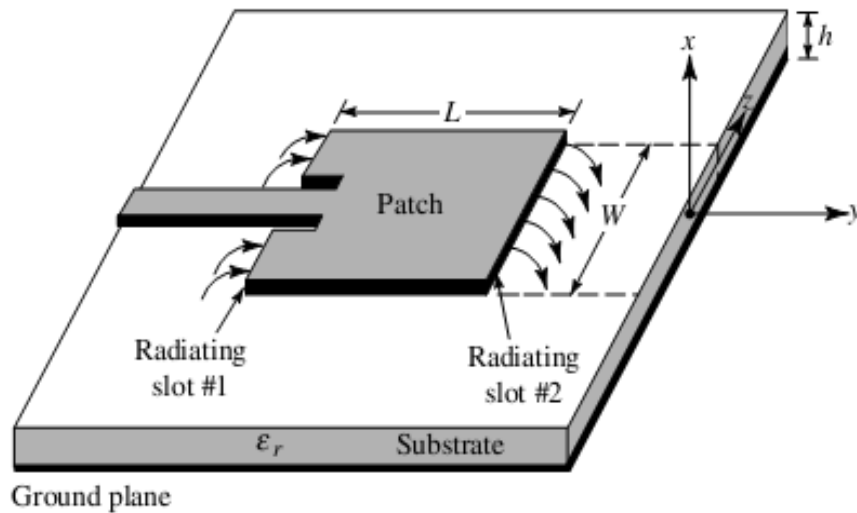

**Fig. 1.1. Structure of microstrip patch antenna [9]**

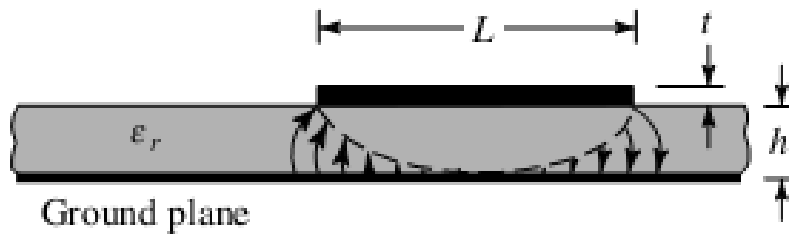

**Fig. 1.2. Side View of microstrip patch antenna [9]**

The elementary configuration of a microstrip patch antenna is a metallic patch (radiating element) printed on a thin and grounded dielectric substrate. The height 'h' of the dielectric substrate is generally  $0.003 \lambda_0 \leq h \leq 0.05 \lambda_0$  and thickness 't' of patch above (front side) the substrate is far less than  $\lambda$  (where  $\lambda$  is the free space wavelength). The microstrip patch antenna radiates relatively broadside beam to the plane of the substrate as shown in the Fig. 1.2. End-fire radiation can as well be accomplished by wise mode selection. For a rectangular patch, the length L of the element is usually in range of  $\lambda/2 < L < \lambda/2$  and the dielectric constants of the substrate are usually in the range of  $2.2 \leq \epsilon_r \leq 15$  [9]

### **1.7 Feeding techniques of microstrip patch antenna**

The antenna is excited by the RF source through the feed line. There are various feeding techniques are available for the microstrip patch antenna [14,15]. Basically these feeding techniques are classified into two categories namely contacting and non-

contacting technique [16]. On the basis of these two broad classifications various feeding techniques have been explained below.

### 1.7.1 Microstrip Line Feed

In this technique, a conducting metal strip is connected directly to the edge of the microstrip patch as shown in Fig. 1.3. The conducting metal strip is lesser in width as compared to the patch and patches with microstrip feed line have advantages over other feeding technique [17]. Since the feed can be etched on the same substrate to provide a planar structure, it simplifies the fabrication process. The level of input impedance can also be controlled easily in this type of feed. The purpose of the inset cut in the patch is to facilitate the impedance matching of the feed line to the patch on substrate without the requirement of any supplementary matching element [14].

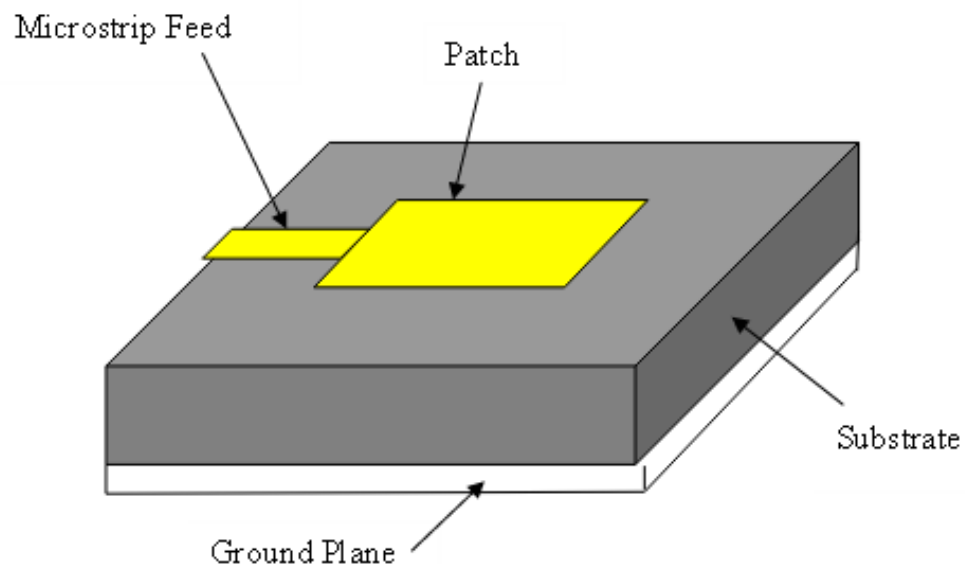

**Fig. 1.3. Patch antenna with microstrip feed line [44]**

### 1.7.2 Coaxial Probe Feed

The Coaxial feed or probe feed is a corporate technique used for exciting (feeding) Microstrip patch antennas. As seen from Fig. 1.4, the inner conductor of the coaxial connector extends through the dielectric to radiating patch and is soldered to the radiating patch element, while the outer conductor is connected to the lower ground plane only [15].

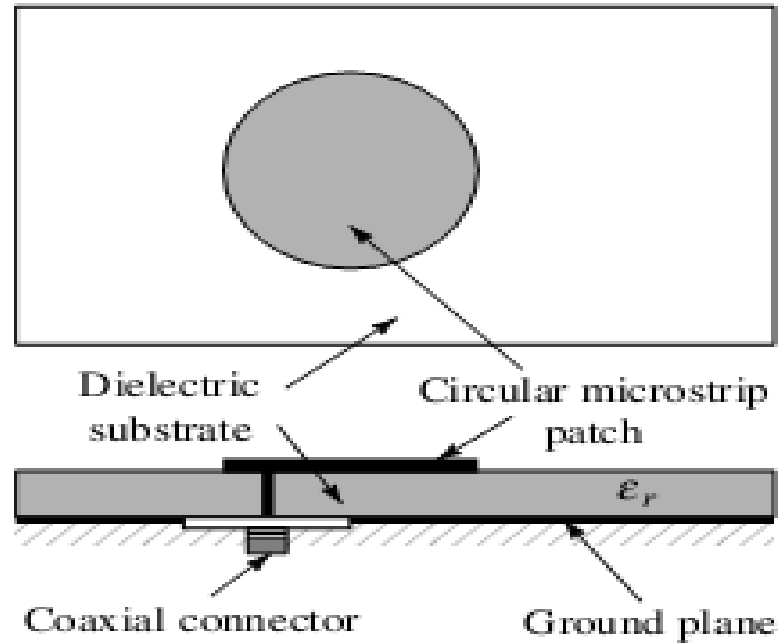
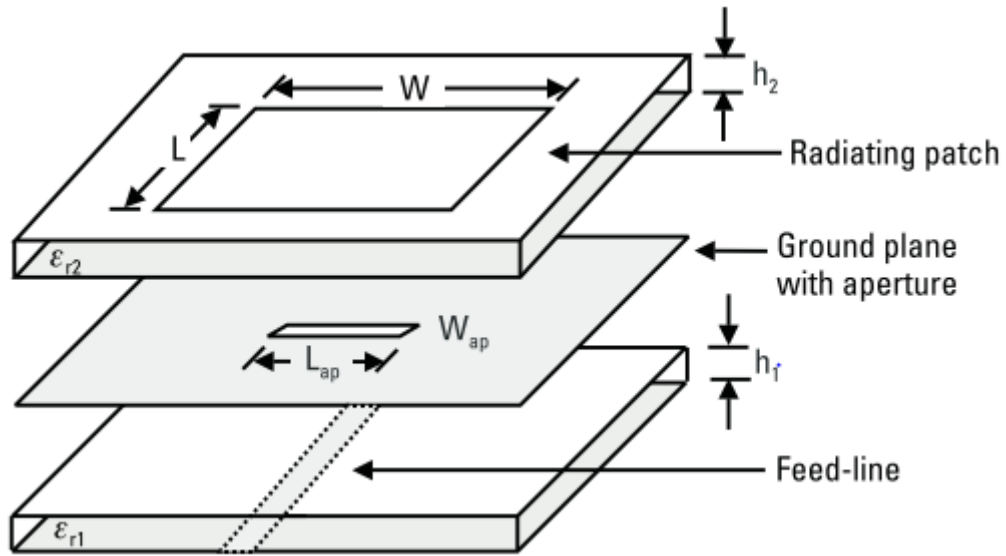

**Fig. 1.4. Patch antenna with coaxial feed [9]**

The foremost advantage of this category of feeding is that the feed can be placed at any desired location as per the requirement in the patch in mandate to match the input impedance. This feeding technique is easy to fabricate and has small spurious radiation. The major disadvantage of this technique is that it provides narrow bandwidth and is also difficult to model meanwhile a hole has to be drilled in the substrate to touch the radiating patch and the connector protrudes outside the ground plane, thus not making it completely planar [14].

### **1.7.3 Aperture Coupled Feed**

In this type of feeding technique, the microstrip feed line and the radiating patch are detached by the ground plane as shown in Figure 1.5. Coupling (connection) between the feed line and the patch is completed through a slot or an aperture in the ground plane. The coupling aperture is generally centred under the patch that leads to lower cross polarization because of symmetry of the configuration. The expanse of coupling from the feed line to the patch is determined by the shape, size and location of the aperture [14].

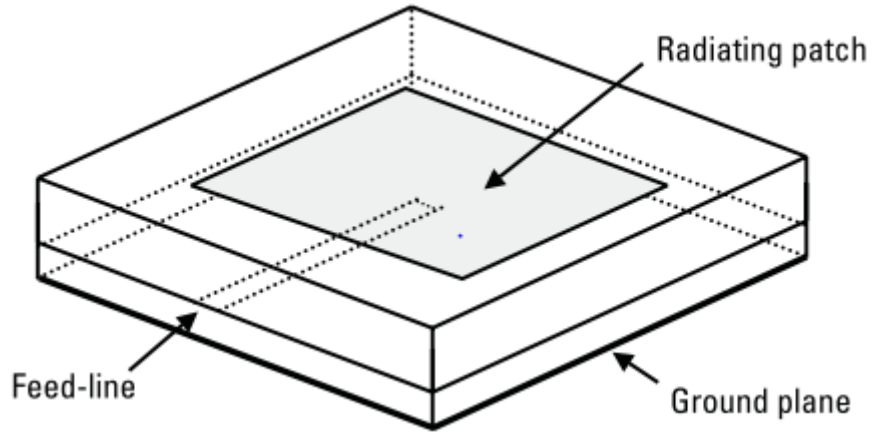

**Fig.1.5. Aperture coupled feed [32].**

In this technique the ground plane separates the feed line and patch, which minimizes the spurious radiations. Mostly, a low dielectric material with more thickness is used for the upper (top) substrate and a thin high dielectric material is used for the bottom substrate to optimize the radiations from the patch [22]. The multiple layer of substrate make this antenna thick with less bandwidth, but it is difficult to fabricate this type of antenna.

#### **1.7.4 Proximity Coupled Feed**

This type of feeding technique is a non-contacting technique so it is also called as the electromagnetic coupling scheme. As shown in Fig. 1.6, that the feed line is sandwiched between the two dielectric substrates. The patch is printed on the top side of the upper dielectric substrate. The main advantage of this feeding technique is that it eliminates spurious feed radiations as well as provides very high bandwidth (as high as 13%) [9]. This scheme also provides choices between two different dielectric media, one for the patch and other for the feed line for the optimization of the individual performances. Matching can be achieved by controlling the length of the feed line and the width-to-line ratio of the patch [14]. Proper alignment of two substrates is required for the fabrication with minimum losses.



**Fig. 1.6. Proximity Coupled Feed [32]**

**Table 1.4. Comparison of Feeding Techniques [16, 17]**

Technique	Advantages	Disadvantages
Microstrip Line	Good Polarization, Easy to fabricate, Monolithic.	Spurious radiations. Must be inset or use transformer to match impedance.
Coaxial Probe	Probe location can excite additional modes and also responsible for the impedance matching.	Impedance matching is highly inductive due to thick substrate.
Aperture Coupled	No spurious radiations neither from feed nor from patch. Eliminates soldering process.	Multilayer fabrication is required.
Proximity Coupling	No contact between feed and radiating patch. Several degree of freedom is available for tuning/matching.	Multilayer fabrication and difficult to optimize.

### **1.8 Different type of materials for patch and substrate**

There are different types of materials available in the market for the patch as well as substrate with different properties, thickness, losses etc.

The patch material is a conductor, its properties varies in the form of conductivity and relative permittivity as shown in the Table 1.5.

**Table 1.5 Patch Antenna Materials [14]**

Material	Conductivity( $\sigma$ )S m <sup>-1</sup>	Relative Permittivity( $\epsilon_r$ )
Aluminium	$15.5 \times 10^7$	1
Brass	$2.6 \times 10^7$	1
Copper	$5.8 \times 10^7$	1
Gold	$4.8 \times 10^7$	1

The substrate material properties varies in terms of the relative permittivity and tangent loss as shown in the Table. 1.6.

**Table 1.6 Substrate Materials [14]**

Material	Relative Permittivity( $\epsilon_r$ )	Loss Tangent( $\tan \delta$ )
Alumina	~9-10	0.0003
FR-4	~4.5	0.025
Silicon	~15.9	0.004
Teflon	~2.1	0.0004
ROGER RO3003	~3	0.0013

The results of the antenna changes with the changing in substrate material as well as substrate thickness [20, 22].

## **1.9 Advantages and disadvantages of microstrip patch antenna**

Microstrip Patch antennas are broadly used in today's world. It is used in mobile, missile systems, satellite communication, GPS, military purposes, GPS etc. as due to its compact size and light weight, less complexity and easy to implement. Some of its advantages and disadvantages described in [14] are described as following:

### **1.9.1 Advantages**

- Small volume i.e. footprint is very small.
- Light weight ideal for aircraft, missiles, or man-packed systems.

- Planer configurations and easily formed into curved surfaces, both uniform and irregular.
- Fabrication cost is very less, hence can be manufactured in large quantity.
- Polarization i.e. linear, circular, elliptical polarization can easily be accommodated.
- Integration i.e. can easily be integrated with MMIC circuits.
- Can be operated at multiple operating frequencies.
- Mechanically robust when mounted on rigid surfaces.
- Exhibit very good cross-polarisation

### **1.9.2 Disadvantages**

- Low operating bandwidth and associated tolerance problems.
- Low radiation efficiency.
- Low gain than conventional antennas.
- Extraneous radiations from feeds and junctions.
- Small power handling capacity.
- Surface wave excitation is present.

### **1.10 Defected Ground Structure (DGS)**

In today's environment, technology demand a single multiband antenna which can be able to operate on different wireless bands and also support features like very small weight with low cost and low profile which is accomplished with extraordinary performance over big frequency spectrum [14]. Therefore Microstrip Patch Antenna using Defected Ground Structure (DGS) is an eminent type of antenna for higher frequency ranges as well as higher bandwidth along with multiband operability. The reduction in size is also possible by implementing microstrip patch antenna with DGS [24]. DGS provides single antenna which can support different frequency operating bands with improved efficiency [25].

Defected Ground Structure (DGS) is the methodology for designing low profile antennas such as microstrip antennas and dielectric resonator antennas [26]. The DGS can be considered as a simplified arrangement of Electromagnetic Band Gap (EBG) structure, from where it was evolved. It exhibits a band-stop property and its area of application involves microstrip transmission lines and circuits [14]. As the name implies the defected ground structure (DGS) is the single or multiple number of defects are etched in the ground plane. Initially the DGS was employed below the feed lines to

improve the radiation characteristics, providing good impedance matching to suppress higher harmonics. The fame of DGS technique has grown amongst present antenna engineers, who have extended the DGS UWB antennas, dielectric resonators, phased arrays, etc. [24].

Defected Ground Structure (DGS) have attractive property to act as band stop filter for some not required frequency bands and also facilitate in reducing antenna size. The defect etched in the ground plane may be of any shape or geometry.

### 1.11 Different Geometries of Defected Ground Structure

There have been two research aspects for adequately utilizing the unique performance of DGS: periodic or non-periodic cascaded configuration [24]. A variety of polygon geometries have been engraved in the ground plane below the feed line that may change the characteristics of antenna. The defects of different shapes are shown in Fig. 1.7, we can chose any shape as per the required characteristics [25].

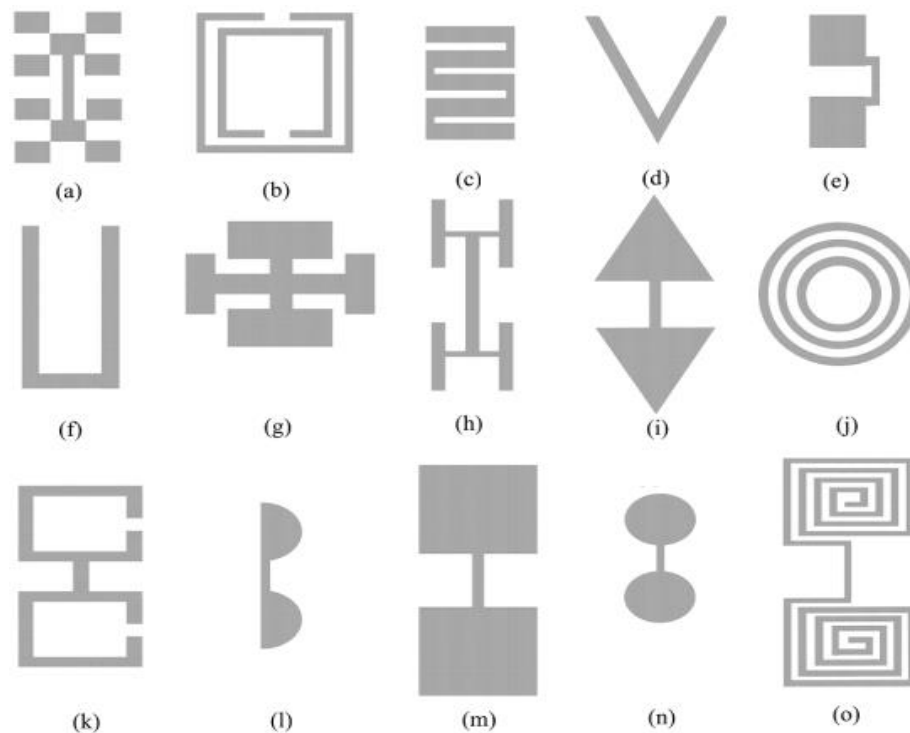

**Fig.1.7. Various DGS Geometries: (a) Fractal (b) Split-ring resonator (c)Meander line (d) V-shaped (e) Square heads connected with U-slots (f) U-shaped (g) Cross-shaped (h) H-shaped (i) Arrow head dumbbell (j) Concentric ring shaped (k) Open loop dumbbell (l) Half-circle (m) Dumbbell- shaped (n) Circular head dumbbell (o) Spiral-shaped [25].**

## 1.12 Working Principle of DGS

In planar microstrip circuits, due to a DGS is located below a microstrip feed line the current distribution direction changes which is responsible for the excitation of electromagnetic waves. The changing electric fields gives rise to the capacitive effect (C), while the surface currents around a defect cause an inductive effect (L). The equivalent circuit of DGS is shown in Fig. 1.8. This, in turn, results in change in resonant characteristics of a DGS, and it is essential for us to determine the equivalent circuits and associated parameters of antenna [24].

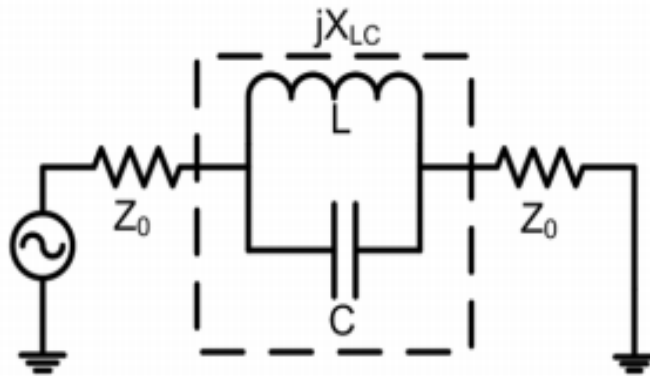

Fig.1.8. Equivalent circuit of DGS [25]

## 1.13 Applications of DGS

### 1.13.1 Slow-Wave Effect

Slow wave effect is the significant advantage of DGS. This helps to reduce the circuit size because with DGS the transmission line has high impedance also slow wave factor increase [24].

### 1.13.2 Stopband Effects

DGS acts as band notched filter for some undesired frequency bands, this effect is called as the stop band effect. Stop band effect is very beneficial for the suppression of leakage transmission, spurious waves and surface waves [25].

### 1.13.3 High Characteristics Impedance

DGS will provide acceptance of high characteristics impedance with the increment in the equivalent inductance and capacitance as compared to the conventional microstrip line. The impedance acceptance of conventional microstrip line is  $100\text{-}130\ \Omega$ , but with DGS it will be more than  $200\ \Omega$  [24].

## **1.14 Thesis Outline**

In **Chapter 1**, the introduction and evolution of the wireless communication system with its standards. The basics of microstrip patch antenna with its feeding techniques and defected ground structure antenna are also discussed.

In **Chapter 2**, Literature review based on evolution of wireless communication, microstrip patch antenna with the effect of defected ground structure. Various designs and properties of dual band and triple band antenna are also discussed.

In **Chapter 3**, Mathematical model of rectangular patch and circular patch antenna are discussed. The working and mathematical model of defected ground structure is also discussed.

In **Chapter 4**, Antenna design and results are discussed with various parameters required for the WiMAX/WLAN applications.

In **Chapter 5**, Antenna fabrication using photolithographic process has been discussed. Then testing of antenna using VNA is explained and comparison of measured and simulated results is presented.

In **Chapter 6**, Conclusion and Future Scope is discussed.

### LITERATURE REVIEW

---

---

*This chapter gives us the idea about the evolution of microstrip patch antenna, knowledge of different feeding techniques, need of defected ground structure (DGS) and the evolution of generations of wireless communication system. This chapter is very helpful to carry on further work after studying the various development in past.*

---

#### 2.1 Evolution of Mobile Communications

**M. M. U. Mir** *et al.* [3] explains the evolution of wireless communication systems with the time period as the demand of wireless communication increasing. With the speedy growth of the mobile phone subscribers, the demand of new technologies with higher data rate increases. The wireless communication concept was firstly introduced in early 1970's. The wireless communication subscribers are increasing by 40% per year. There was requirement of new wireless standards and systems. This paper had explained all the four generations and also gives brief overview of coming soon fifth generation. The generations are differ through their data rate, with the increasing generation data rate is increasing and for higher data rate large bandwidth is required.

**G. Cheng** *et al.* [4] discussed the importance and need of forth generation (4G) in the wireless communication systems. It explained all the previous generations but its main emphasis was on the 4G. Actually the 4G has played a revolutionary part in the communication system. It reveals that the development in world is endless, there is always room for the development. 4G provides the facility of mobile TV and high speed video streaming and video calling. The high speed wireless communication becomes an essential part of our work, entertainment, lives and study. It also provides the way to further advancement.

#### 2.2 Microstrip Patch Antenna with various parameters

**K.R. Carver** *et al.* [10] presents a survey of various practical and theoretical analysis of the microstrip antenna. Study of several substrate characteristics is carried out in relation to the resonant frequency and dielectric constant tolerance. It provides the study of electrical, mechanical and thermal properties of the substrate. Both the standardized

rectangular as well as circular patches are practically analysed, and variations in design are also studied for the circularly polarized microstrip patch antennas. It also explained the efficiency, quality and bandwidth of typical patch designs and also provides the trade-off between bandwidth, efficiency and quality factor. It specifies the precarious needs for further research and development for the microstrip patch antenna.

The analysis of fundamental properties and degrees of design freedom of the antenna such as size, shape and radiation pattern is explained by **J.R. James** in [11]. This paper also defines the typical factors defining the electrical performance of the antenna such as beam shape and side lobe envelope, polarization, omnidirectional properties, degree of beam scan, input matching, efficiency, bandwidth, etc. this also propose the new developments in antenna at that time. It was conclude that the microstrip antenna technology will always remain rich with creative ideas and a vibrant topic of discussion as long as the wireless communication system persist.

**C. Peixeiro et al.** [12] presents an historical perspective of the development of the microstrip patch antennas. A survey on the microstrip antenna papers of last 40 years is carried out. In the early years the technology is specifically analysed in detail. Then in the last 30 years the fast evaluation of the research and development activities carried out. Finally the present situation of the microstrip antenna field and future trends are examined. Until 50s there is only introduction of microstrip antenna. The time period under analysis can be divided into 3 stages: the early years, the fast development period and the last decade. These periods are analysed in detail.

**D. M. Pozar** [13] gives a brief overview of the elementary characteristics of microstrip antennas and then focusses on the time to time significant innovative developments in microstrip antenna technology that have been completed in the last numerous years. Emphasis was given on the on developing the new antenna configurations for improvement in analytical modelling, manufacturability and electrical performance of microstrip antenna and arrays. For new configurations it basically emphasis on the proximity feed technique. It also proposes the band width enhancement techniques. Then proposes the array models.

**A. Mandal et al.** [16] provides the analysis and comparison of different feeding techniques for the rectangular microstrip patch antenna. The suitable technique was chosen on the basis of impedance matching. In this the comparison of coaxial feed and

the microstrip feed was carried out with the aid of ANSOFT HFSS. The antenna was designed to resonate at 2.4GHz, and to obtain the minimum return loss the position of the feed line is varied. This shows that the coaxial feed required more position adjustments for impedance matching and the microstrip feed line impedance matching be governed by the inset depth. By the discussion it was concluded that the coaxial feed shows better impedance matching but less bandwidth is obtained through it.

**G. Singh et al.** [17] provides the comparison of two feeding techniques that are microstrip line feed and coaxial feed. It works on the improvement of the gain, return loss and bandwidth of the microstrip antenna by using different feeding techniques. Firstly the microstrip patch antenna with coaxial probe feeding is studied. The achievement of the higher gain with probe feeding was the main focus of attention. The variation of feed point over the feed line gives the flexibility to get higher gain and match the impedance. This is proved here that the coaxial feed is better impedance matching technique than the microstrip line feed, which affects positively to improve the gain, return loss and bandwidth.

**A. Elrashidi et al.** [18] explains the fringing field effect on the performance analysis and theoretical modelling of the microstrip patch antenna. The effect of fringing field was studied on resonance frequency of antenna as a function of curvature of the cylindrical microstrip patch antenna. Then the effect of variable dielectric constant is studied on the resonance frequency of the antenna. For this study three different substrate materials named Epsilam-10 ceramic-filled Teflon, RT/duroid -5880 PTFE and K-6098 Teflon/Glass are used for verifying the results with RT/duroid PTFE. The study shows that the effect of curvature on the resonance frequency is very small.

**S. Sankaralingam et al.** [19] gives a novel approach for the measurement of the dielectric constant of the substrate material of the wearable antennas. The wearable antennas are the textile antennas consist of the radiating patch which is printed on the fabric substrate material. The fabric material's dielectric constant can easily calculated from the resonant frequency of the patch. There was six type of textile antennas were considered under study for the dielectric constant measurement. The Bluetooth antenna made from the polyester fabric substrate was taken into consideration, and this antenna had given the worthy results as per the requirements. The study of these textile antennas shows that the wearable antennas can be designed using the microstrip patch antenna

technology with the advantages like fast measurement, good accuracy and meek sample preparation.

The study of rectangular microstrip patch antenna and the effect of changing various dielectric materials on the results of antenna has been presented by the **K. V. Rop** *et al.* in [20]. It provides the evidence of dependence of rectangular microstrip patch antenna performance on the dielectric constant of the substrate material. From the study it was concluded that the thick substrate with low dielectric constant is required for the large bandwidth. The substrate material with low dielectric constant will give superior antenna performance.

**A.F. Tinoco S.** *et al.* [21] discusses the new approaches for the analysis and design of rectangular microstrip antennas. The techniques and approaches provided in this paper are appropriate for the computer-aided-design procedures. These techniques can be implemented by the students with the help of a simple mathematical software e.g. Mathematica.

The effect of changing the electrical thickness of the substrate on the electrical and mechanical performance of antenna had been discussed by **M. Kara** in [22]. Due to increasing the substrate electrical thickness the resonance frequency decreases. Radiation efficiency decreases because the surface wave radiation increases and the antenna impedance reduces. Due to decrease in the radiation efficiency the gain of antenna also decreases. As the gain bandwidth product is constant, as the gain reduces the bandwidth increases.

**T. N. Chang** *et al.* [23] provides approach for the improvement in the microstrip patch antenna performance. The return-loss bandwidth of antenna was improved. The improvement was carried out by the implementing the stacked patch structure. The gain was also improved by using these techniques. The coupled patch is replaced by a pair of strips that are etched on the substrate. The optimized performance is achieved with a profile of  $0.125 \lambda$ .

### **2.3 Microstrip Patch Antenna with Defected Ground Structure**

**L.H. Weng** *et al.* [24] provides the synopsis of the defected ground structure (DGS). The DGS was evaluated from the traditional photonic band gap (PBG) structures. The DGS provides the extraordinary characteristics impedance that is very beneficial for the

digital systems. The DGS is actually a defect of any shape is etched from the ground plan of the antenna. By the defect under the microstrip line, the capacitance (C) and inductance (L) of the antenna changes, this tends to alter the electrical characteristics of the antenna. Therefore the equivalent circuit of DGS have been studied with various designs of MMIC for the optimized performance of the antenna.

**S. Biswas** *et al.* [25] explains the working of defected ground structure with the effect of defect in the ground plane on the antenna performance. A number of defects are etched in the ground plane for the improvement of the radiation characteristics of antenna. It also helps to suppress the mutual coupling offered by the neighbouring elements. It provides the techniques for the optimization of microstrip patch antenna with defected ground structure. The field of defected ground structure is very vast, so there was always a room for the further research and advancement.

**Y. J. Sung** *et al.* [26] explains that the microstrip patch antennas fundamentally have high input impedance at the resonant frequencies for different wireless applications. For the efficient working of antenna it should have to follow the techniques for the harmonic suppression and have proper impedance matching. To achieve the both explained requirements a novel microstrip patch antenna was designed using the 1-D photonic band gap (PBG) structure. By the utilization of PBG in microstrip patch antenna the characteristics impedance and the effective impedance of the microstrip feed line is increased, therefore there is no requirement of additional circuitry for impedance matching of the microstrip feed line. Due to installation of PBG structure the harmonic suppression as well as the reduced reflection coefficient is obtained.

**C Garg** *et al.* [27] presents a tutorial outline of the new approach for designing compacted filters like low pass, band stop and band pass having several advantages than Photonic Band Gap (PBG). This technique is termed as Defected Ground Structure (DGS). It also presents basic transmission characteristics and conceptions with corresponding circuit models of varieties of microstrip patch antenna with DGS units. The photonic band gap structures were the main structures responsible for the evolution of defected ground structure. It also have application for the designing of millimetre wave structures for the several wireless applications. DGS provides the more degree of flexibility for the microwave and design applications.

**A. K. Verma** *et al.* [28] proposes a microstrip patch antenna with compact size and thin substrate and low dielectric constant. To achieve the better efficiency as well as large bandwidth without the increment in size and weight of antenna, the microstrip patch antenna with defected ground structure is used for analysis and designing. The antenna is analysed and simulated with the aid of high frequency simulator HFSS. The MPA with DGS has power to attenuate the frequency harmonics without the requirement extra attenuation circuit.

**H. Elftouh** *et al.* [29] designed an antenna with defected ground structure for the miniaturization of size of microstrip patch antenna without the degradation in performance. The resonance frequency of the antenna is altered from 5.7 GHz to 3 GHz using the DGS of suitable geometry that may be one cell or two cell geometry. By this application the size of antenna is reduced by 50%.

## **2.4 Dual Band Antenna**

**Q. X. Chu** *et al.* [33] proposed a compact dual band antenna which was excited by the coplanar waveguide fed (CPW). This proposed antenna operates for all the frequencies of the WLAN and WiMAX. The two wide bands of this antenna centred at 2.5 GHz and 5 GHz. The overall dimension of this antenna was  $28 \times 33$  mm<sup>2</sup> with simple planer structure and FR4 was used as substrate. The proposed antenna shows very good performance analysis like good radiation characteristics and adequate gain over the both operating frequency bands.

**H. W. Liu** *et al.* [34] designed a new dual band antenna with dual mode approach and by the utilization of the defected ground waveguide (DGW). This antenna have band pass filter (BPF) like properties. It uses the pentagonal shape DSW resonator and defected corner amended discomposure adjust the nature and strength of the coupling between the degenerate modes. There was very good match between the measured and simulated results were obtained. The size of antenna was very compact and can be fabricated with great ease.

**H. S. Ding** *et al.* [35] proposed a very compact dual band microstrip patch antenna. The concentric double split rings are used for the two resonant frequencies that cover the bands of WLAN frequency bands. This antenna has overall substrate dimension of  $9 \times 24$  mm<sup>2</sup>. Two tuning arms were also added to the microstrip line feed for the tuning

of the upper frequency bands. The antenna was fabricated on the FR4 substrate and the results are practically measured. There was good promise between the measured and simulated results was achieved. The small distortion was obtained at higher frequencies because of increasing electrical length of antenna.

**C. Y. Huang** *et al.* [36] proposed a dual-band monopole patch antenna for the WLAN operation. The overall dimension of this antenna was  $50 \times 30$  mm<sup>2</sup>. The antenna has enough bandwidth in both the resonant frequency bands required for the WLAN operation. This microstrip patch antenna shows good radiation characteristics and better efficiency.

## 2.5 Triple Band Antenna

**R. L. Li** *et al.* [37] discussed a unidirectional coplanar antenna that has better impedance matching and very high gain, but there was a limitation of very large size i.e. is of  $100 \times 60$  mm<sup>2</sup>. This antenna was consists of five dipoles, out of which one upper dipole is for 2.4 GHz band, 3.5 GHz band is covered by two longer dipoles and the remaining two small dipoles covers the 5 GHz band. This antenna was fabricated on the thin ROGER RT/Duroid 5880 substrate with thickness ‘t’ of 0.5 mm and dielectric constant ‘ $\epsilon_r$ ’ of 2.2. This approach also explained that the antenna become directional at higher frequency mode and provides a good unidirectional pattern over all three frequency bands.

**C. Kumar** *et al.* [38] presents a rectangular microstrip patch antenna with defected ground structure. The discussed approach is highly suitable for the realization of single element or multi element coplanar antenna, microstrip sensors and also antenna arrays. For large band width, large aspect ratio is required but this leads poor mutual coupling as well as poor cross polarization isolation. It explained the DGS working through its model to suppress the cross polarization fields. Actually the fringing fields are responsible for the cross polarization radiation in circular patch antenna. The defects installed along the boundary of patch interact with the cross polarization fields, but does not affect the radiation mode.

**X. L. Sun** *et al.* [39] proposed a monopole microstrip patch antenna for the triple band applications. This antenna had simple design consisting of a short stub and two branches as the radiator element. The antenna is analysed, designed and simulated using

the CST Studio Suit. To verify the simulated results, the antenna was fabricated and results are measured using the VNA. The measured and simulated result shows that the antenna had good radiation pattern, gain and antenna efficiency.

**K. G. Thomas** *et al.* [40] presented a low profile tri-band antenna for the WiMAX/WLAN applications. This antenna has dimensions of  $38 \times 30 \times 0.8 \text{ mm}^2$ . The antenna had front side with rectangular shape radiating element and ground plane has trapezoidal shape. In this some more rectangular metal strips are attached to the rectangular to make antenna resonate at frequencies required for the WiMAX and WLAN applications. Basically in this antenna the current paths were increased for the different resonant frequencies. It also explained the cause of distorted radiation pattern in the at 5.5 GHz frequency band i.e., because of asymmetrical feeding and feed line losses due to improper impedance matching, but it has reduced height as well as better impedance matching.

A novel microstrip patch antenna with microstrip feed slot is proposed for the tri-band applications is proposed by the **F.C. Ren** *et al.* [41]. It was a compact antenna with L-shape microstrip feed line. This antenna was built with the help of double T-shaped slots etched in the ground plane as the application of defected ground structure. It provides the analysis, design and fabrication of antenna. The difference between the measured and simulated results. The matched results shows that this antenna can be practically implemented and should operate in the frequency bands of WiMAX and WLAN frequency bands with good radiation characteristics.

A very small compact size antenna was proposed for multi - frequencies required for multiple applications. This antenna has consists of small circular ring shape strip with curved shape defected ground structure, having defect isosceles triangle shape. For triple band operation another Y-shaped metal strip is attached to inner side of the circular strip of the radiating element. This antenna was also for the WiMAX/WLAN applications proposed by **J. Pei** *et al.* in [42]. The first band of operating frequency was achieved by the outer circular metal strip and the second band is from the Y- shaped strip. The curved shape ground plane of this antenna acts as the band notched filter for some undesired frequencies that will give rise to the third required frequency band. This antenna has small, less efficiency as moving from lower frequency band to higher frequency band and moderate radiation pattern.

## 2.6 Gaps

- The results of antenna can be altered with the change in thickness and dielectric constant of the substrate material. Substrate that gives proper optimized results need to be chosen [20].
- At low dielectric constant of substrate better return loss can be achieved with the satisfaction of the conditions of VSWR after choosing the proper shaped substrate. Further work can be done to examine the antenna by considering the slot shape same as the patch shape [27].
- Better efficiency can be obtained by the using the DGS of proper shape for required application [28].
- The size of patch antennas can be reduced without the degradation in performance of antennas using a novel structure called Defected Microstrip Structure and Defected Ground Structure. Gain/Bandwidth can also be increased using DGS [29].
- A single microstrip patch antenna can be used for the multi-frequency applications even without increasing the dimensions of the substrate and retaining the advantages of microstrip patch antenna. Further work can be carried on for making the multi frequency antenna with the help of different shapes of DGS [34].
- Harmonic suppression need to be improved with the help of DGS, to reduce the side lobe level at higher frequencies [26,38].

## 2.7 Objective of Thesis

Based upon the gaps mentioned above, following objectives had been designed to carry out the thesis work:

- 1) Design and simulate novel tri-band microstrip patch antennas to achieve:
  - Enhancement in the gain and the total efficiency of antenna.
  - Improvement in the return loss.
  - Miniaturization of the size of antenna.
  - Antenna should have low VSWR.
- 2) Perform evaluation of the two different shape tri- band antennas with different DGS shapes in terms of antenna gain, return loss and efficiency.
- 3) Fabrication and testing of the optimized antenna.

**MODELLING OF MPA WITH DGS**

*This chapter describes the mathematical model for rectangular patch antenna as well as of circular patch antenna. The equivalent circuits and analysis of defected ground structure is also presented.*

**3.1 Mathematical Model for Microstrip Patch Antenna**

There are many models such as transmission line model, cavity model and full wave model for the analysis of microstrip patch antenna. One of the utmost popular model is the transmission line model [9]. The transmission line model is commonly used because of its simplicity in model design, although it has less accuracy. Whereas the cavity model cannot be used because of its complex analysis. Hence forth the transmission line model has been used for said antenna discussion.

**3.1.1 Transmission line model**

The transmission line model is used for the mathematical analysis of the microstrip antenna. This model represents the microstrip antenna having two slots of width  $W$  and height  $h$ , separated by a single transmission line of length  $L$  as shown in Fig. 3.1 Basically the microstrip line is essentially non-homogeneous line in between of two dielectrics, typically the substrate and air. The transmission line model also take the fringing effect into consideration. Due to finite dimensions of the patch, the fields undergo fringing at the finite edges of the patch [9].

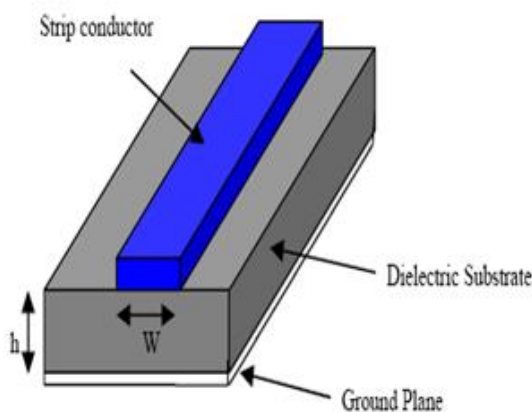

**Fig. 3.1. Microstrip line [9]**

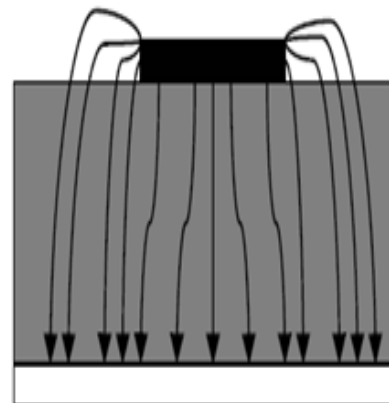

**Fig. 3.2. Electric field line [9]**

Hence, as seen from Fig. 3.2 approximately all the electric field lines be located in the substrate and portions of some lines resides in the air. The emerging out of these waves in air out of the substrate is known as the fringing effect. As a consequence of this phenomenon, this transmission line model cannot support clean transverse electric-magnetic (TEM) mode of transmission, since the phase velocities would be different in the substrate and the air substrate [14].

### 3.1.2 Rectangular patch antenna

Due to all above explained reasons, the dominant mode of propagation would be the quasi-TEM mode. Therefore, an effective dielectric constant ( $\epsilon_{\text{reff}}$ ) must be obtained in order to taking the consideration the fringing effect and the wave propagation inside the line. The value of  $\epsilon_{\text{reff}}$  is somewhat less than because the fringing fields nearby the edges of the patch are not restricted in the dielectric substrate but are moreover spread in the air as shown in Figure 3.2. The expression for  $\epsilon_{\text{reff}}$  is given in [9].

$W/h > 1$

$$\epsilon_{\text{reff}} = \frac{\epsilon_r + 1}{2} + \frac{\epsilon_r - 1}{2} \left[ 1 + 12 \frac{h}{W} \right]^{-1/2} \quad (3.1)$$

where,

$\epsilon_{\text{reff}}$  = Effective dielectric constant

$\epsilon_r$  = Dielectric constant of substrate

$h$  = Height of dielectric substrate

$W$  = Width of the patch

The fringing fields along with the width can be modelled as radiating slots and electrically the patch of the microstrip antenna look greater than its physical dimensions. The dimension of the patch along its length have now been extended on each end by a distance  $\Delta l$ , and is given by [9]

$$\Delta l = 0.412 \frac{(\epsilon_{\text{reff}} + 0.3) \left( \frac{W}{h} + 0.264 \right)}{(\epsilon_{\text{reff}} - 0.258) \left( \frac{W}{h} + 0.8 \right)} \quad (3.2)$$

The effective length of patch  $L_{\text{eff}}$  now becomes

$$L_{\text{eff}} = L + 2\Delta l \quad (3.3)$$

Given the resonance frequency  $f_0$ , the effective length is given by [2]

$$L_{\text{eff}} = \frac{\lambda_0}{2\sqrt{\epsilon_{\text{reff}}}} \quad (3.4)$$

### 3.1.3 Circular patch antenna

The circular microstrip patch antenna is another basic configuration of antenna as shown in in Fig. 3.3 that is widely used for various application. The fields of circular patch antenna is explained with the help of Bassel function [32].

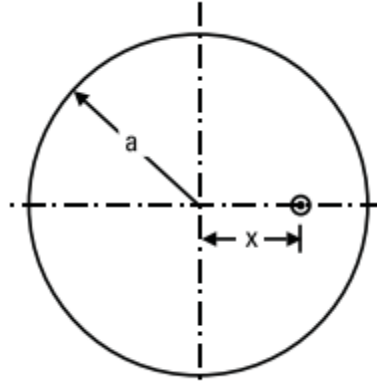

**Fig. 3.3. Circular microstrip patch antenna**

The resonance frequency of circular patch antenna is calculate by the following formula:

$$f_0 = \frac{k_{nm}c}{2\pi a_e \sqrt{\epsilon_e}} \quad (3.5)$$

where  $k_{nm}$  is the derivative of the  $m^{\text{th}}$  of the Bessel function of order  $n$  [1, 4].

For the fundamental  $TM_{11}$  mode, the value of  $k_{nm}$  is 1.84118 [9]. The effective radius ( $a_e$ ) and the effective dielectric constant ( $\epsilon_e$ ) are the of the circular microstrip antenna.

The fringing fields end to end of the circumference of the circular microstrip antenna are taken into description by replacing the patch radius 'a' by the effective radius 'a<sub>e</sub>',

$$a_e = a \left\{ 1 + \frac{2h}{\pi a \epsilon_r} \left[ \ln \left( \frac{\pi a}{2h} \right) + 1.776 \right] \right\}^{1/2} \quad (3.6)$$

The  $\epsilon_e$  is calculated by

$$\epsilon_e = C(a, h, \epsilon_0 \epsilon_r) / C(a, h, \epsilon_0) \quad (3.7)$$

where  $C(a, h, \epsilon_0 \epsilon_r)$  and  $C(a, h, \epsilon_0)$  are the total capacitances of the dominant  $TM_{11}$  mode of circular microstrip antenna with and without a dielectric substrate, respectively. These can be calculated as

$$C(a, h, \epsilon_0 \epsilon_r) = \frac{0.8525 \epsilon_0 \epsilon_r \pi a^2}{h} + 0.5 C_f \quad (3.8)$$

where [32],

$$C_f = 2a\epsilon_0 \left[ \ln \left( \frac{a}{2h} \right) + 1.41\epsilon_r + 1.77 + \frac{h}{a} (0.268\epsilon_r + 1.65) \right] \quad (3.9)$$

### 3.2 Modelling Techniques of Defected Ground Structure

The modelling methods can be classified into following three categories:

#### 3.2.1 LC and RLC circuit modelling

The equivalent circuit of the one-pole Butterworth prototype and DGS are shown in Fig. 3.4. Take the example of a rectangular dumbbell shape DGS, it will increase the effective inductance and the current route length [24]. The defected part i.e., etched part accumulates the charge and the effective capacitance of the microstrip line increases. The L-C equivalent circuit of the DGS is shown in Fig. 3.4 with 'L' and 'C' are as equivalent inductance and equivalent capacitance. This equivalent circuit forms the resonant phenomenon in the calculation of S-parameter [25].

As the area of defect in unit lattice increases, the effective series inductance increase and increasing the series inductance gives rise to a lower cut off frequency. When the etched gap distance increases, the effective capacitance decreases so that the attenuation pole location moves up to higher frequency [24].

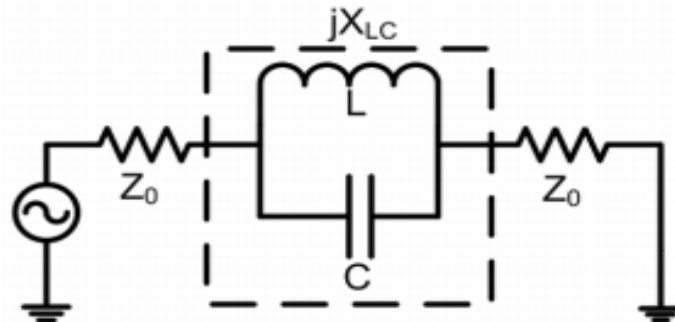
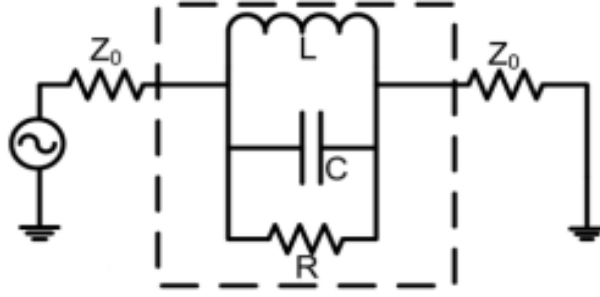

Fig. 3.4. LC Parallel Combination [25].



**Fig. 3.5. LCR Parallel Combination [25].**

In order to match Butterworth low-pass filter reactance to the DGS equivalent reactance, the values of both circuits should be equal at the cut off frequency. So equivalent inductance (L) and capacitance (C) are derived as follows [25]

$$X_{LC} = \frac{1}{\omega_0 C} \left( \frac{\omega_0}{\omega} - \frac{\omega}{\omega_0} \right) \quad (3.10)$$

where  $\omega_0$  is the resonance angular frequency of the parallel LC resonator.

$$C = \frac{\omega_c}{Z_0 g_1} \cdot \frac{1}{\omega_0^2 - \omega_c^2} \quad (3.11)$$

$$L = \frac{1}{4\pi^2 f_0^2 C} \quad (3.12)$$

where  $\omega_c$  is the cut-off angular frequency.

If the resistance corresponding to the dielectric, radiation and conductor losses are taken into consideration then another factor resistance (R) comes in parallel with LC equivalent circuit as shown in the Fig. 3.5.

Equations for RLC equivalent circuit [25].

$$C = \frac{\omega_c}{2Z_0(\omega_0^2 - \omega_c^2)} \quad (3.13)$$

$$L = \frac{1}{4\pi^2 f_0^2 C} \quad (3.14)$$

$$R(\omega) = \frac{2Z_0}{\sqrt{\frac{1}{|S_{11}(\omega)|^2} - (2Z_0(\omega C - \frac{1}{\omega L}))^2 - 1}} \quad (3.15)$$

### 3.2.2 $\pi$ Shaped equivalent circuits

It was difficult to implement the DGS circuits for the harmonics termination to satisfy simultaneously the excellent pass band and stop band characteristics. The  $\pi$  Shaped Equivalent Circuit is more accurate equivalent circuit models than the LC and RLC equivalent circuits[24].

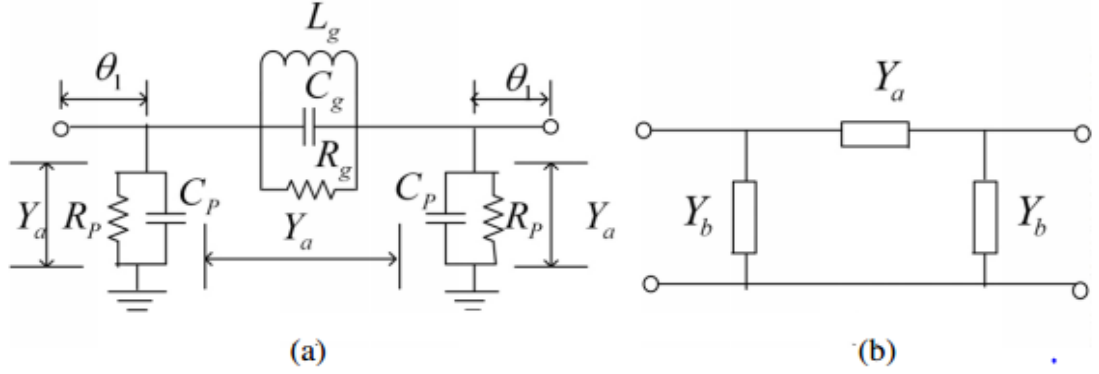

**Fig. 3.6. (a)  $\pi$  Shaped equivalent structure (b)  $\pi$  Shaped structure [24].**

The  $\pi$  shaped DGS equivalent circuit is shown in the Fig. 3.6. This will simulate both phase vs frequency and amplitude vs frequency characteristics. The S-parameter calculation of this circuit is more complex than the simple LC and RLC equivalent circuits. The calculation of ABCD parameter is given by following [24].

$$\begin{bmatrix} A & B \\ C & D \end{bmatrix} = \begin{bmatrix} 1 + Y_b / Y_a & 1 / Y_a \\ 2Y_b + Y_b^2 / Y_a & 1 + Y_b / Y_a \end{bmatrix} \quad (3.16)$$

The various parameter calculation is mentioned below.

$$Y_a = 1 / R_g + jB_r \quad (3.17)$$

$$Y_b = 1 / R_p + jB_p \quad (3.18)$$

$$C_g = \frac{B_r}{w_2 \left( \frac{w_1}{w_2} - \frac{w_2}{w_1} \right)}, \quad (3.19)$$

$$L_g = \frac{1}{w_2^2 C_g} \quad (3.20)$$

$$C_p = \frac{B_p}{w_1} \quad (3.21)$$

### ANTENNA RESULTS & DISCUSSION

---

---

*This chapter explains the antenna designing with the optimization of various parameters and dimensions of antenna. The antennas are designed, optimized and simulated with the aid of CST Microwave Studio<sup>®</sup> software after the calculation of various parameters and desired application of antenna. The results of various antennas are discussed with alteration of various parameters.*

---

#### 4.1 Methodology

The conventional antenna have circular strip shape patch enclosing a Y-shaped strip and have curved shaped ground plane with isosceles triangle shaped defect. In this thesis work different shape of patch and different shape of defected ground structures have been proposed for the same triband applications. There are two antennas are proposed, the first design have square shape metal strip patch enclosing a U-shape metal strip having curved shape ground plane with three square shape ground defects of different dimensions. The second novel antenna have Y-shaped metal strip enclosed by a circular shape metal strip and curved shape ground with three polygon defects of different shape and dimensions. The performance evaluation and comparison of conventional antenna and both novel antennas has been presented in terms of gain, bandwidth, efficiency and side lobe level.

The traditional antennas are analysed, simulated and fabricated using the FR4 substrate, but the proposed antenna is simulated using ROGER 3003 due to following advantages:

- FR4 has higher dissipation factor and tangent loss than ROGER 3003. Tangent loss of FR4 is 0.020 and of ROGER 3003 is 0.0013.
- The dielectric constant of FR4 is not stable all over the length of antenna, but ROGER 3003 have stable dielectric constant due to this it will provide more predictable performance than the FR4.
- ROGER 3003 will provide higher gain as well as more moisture control for practical applications.
- ROGER 3003 will provide higher gain due to more harmonic suppression at higher frequencies because in this spurious radiations are very less.

## 4.2 Conventional Design for Triple Band Antenna with DGS

### 4.2.1 Antenna design

A triple band microstrip patch antenna performance has been analysed with defected ground plane. The major applications of this said antenna could be seen in the area of WLAN/WiMAX. This antenna was fabricated on the FR4 substrate with thickness 'h', tangent loss ' $\delta$ ' is 0.02 and relativity permittivity ' $\epsilon_r$ ' is 4.4. The gap 'g' between the Y-shape strip and outer circular ring is responsible for the mutual coupling between the two metal strips.

The main front side i.e. radiating patch of this antenna consists of a circular ring surrounding a Y-shape metal strip and  $50\Omega$  microstrip feed line attached to the outer circular ring as shown in the Fig. 4.1 (a). There should be proper gap between the outer circular strip and Y-shaped strip for the proper mutual coupling [42].

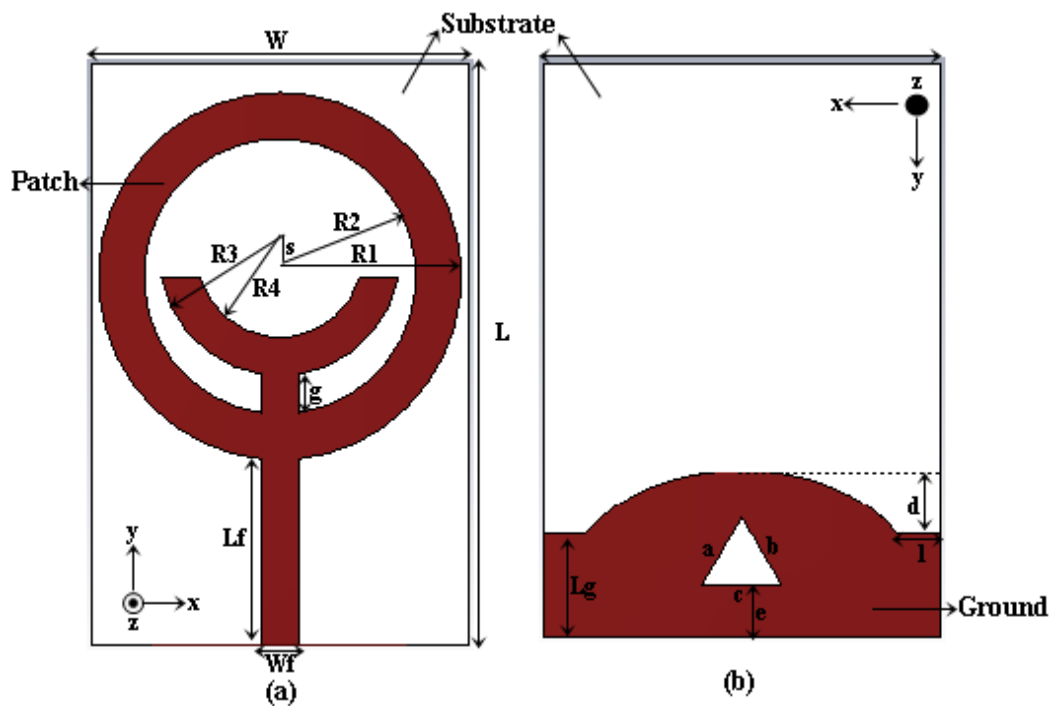

Fig. 4.1 (a) Front view of antenna (b) Back view of antenna [42].

The ground plane of this antenna have cambered structure and a defect of isosceles triangle shape as shown in the Fig. 4.1 (b). The defect etched below the microstrip feed line provides the better impedance matching.

The various dimensions of this antenna are shown in the Table 4.1.

**Table 4.1 Parameters of conventional antenna [42]**

Parameter	Size	Parameter	Size
W	25.0 mm	L	38.0 mm
$L_g$	7.0 mm	H	1.59
$W_f$	2.4 mm	$L_f$	12.06 mm
R1	12.0 mm	R2	9.0 mm
R3	8.0 mm	R4	5.5 mm
g	2.51mm	s	1.5 mm
d	4.0 mm	l	2.7 mm
a	5.15 mm	b	5.15 mm
c	5.0 mm	e	3.5 mm

#### 4.2.2 Return Loss Analysis of Antenna

The return loss of antenna is the power reflected back by the antenna during transmission. The antenna will provide better impedance matching with increase in negative value of S11 (dB) parameter.

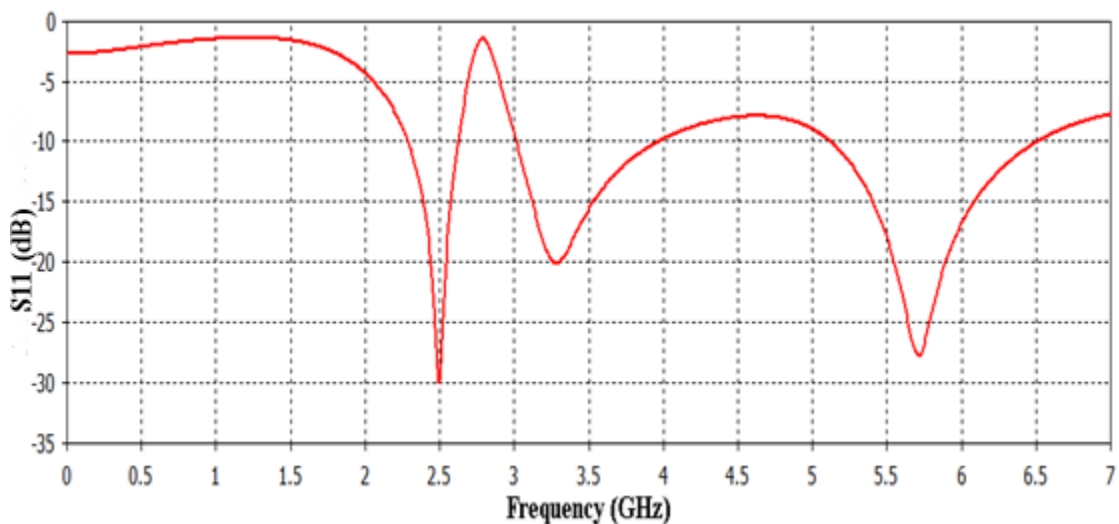

**Fig. 4.2. Return loss of conventional antenna.**

The simulated return loss result of this proposed tri-band antenna with DGS is shown in the Fig. 4.2. From the simulation it is obtained that the return loss i.e. below -10 dB are about -38.87 dB at frequency 2.5 GHz (first band), -19.55 dB at frequency 3.34GHz (second band) and -30.92dB at frequency 5.7GHz (third band) respectively. The

bandwidth of three bands are 0.270 GHz (2.31-2.59GHz), 0.900GHz (3.05-3.95GHz) and 1.030GHz (5.11-6.41GHz).

In this conventional antenna the first frequency band is obtained through the outer circle, second band is obtained through the combination of Y-shape strip and outer circle and the third band is obtained through the institution of the curved ground plane with isosceles triangle shape defect. The defected ground is responsible for the third wideband with great impedance matching.

#### 4.2.3 Gain of the Conventional Antenna

**Table 4.2. Peak gain of antenna in different frequency bands [42]**

Frequency band	Peak Gain
2.31-2.59 GHz	1.85 dBi
3.05-3.95 GHz	2.19 dBi
5.11-6.41 GHz	2.57 dBi

The gain obtained through this antenna is very less even at high frequencies. The side lobe level of this antenna is also very high at high frequencies due to less harmonic suppression.

So after the analysis and evaluation of the conventional design, the new antennas have to be designed to satisfy the following objectives.

- Enhancement in the gain.
- Improvement in the return loss.
- Miniaturization of the size of antenna.
- Antenna should have low VSWR.
- Enhancement in total efficiency of antenna.
- Improved side lobe level.

### 4.3 A Novel Microstrip Patch Antenna using Square Shaped Ground Defects for WiMAX/WLAN Applications (Antenna 1)

This tri-band patch antenna square shape defects in ground plane is designed for the WiMAX/ WLAN application. The configuration of this proposed tri-band antenna is shown in the Fig. 4.3. The antenna patch and ground are printed on the ROGER RO3003 substrate of area  $36 \times 24 \text{ mm}^2$  having thickness of 1.52 mm, with a relative permittivity ( $\epsilon_r$ ) of 3 and having a tangent loss ( $\delta$ ) of 0.0013. The antenna substrate with low relative permittivity and more thickness provides the good efficiency, antenna performance and larger bandwidth [9].

#### 4.3.1 Antenna design

The main radiating patch is printed on the front side of the substrate, it comprises the square metal strip shape patch surrounding a U shape metal strip. The square metal strip and the U shape strip are connected through the strip 'c'. The length of the strip 'c' controls the mutual coupling between the square shape and U shape metal strip. The length of the strip 'c' is chosen where the various optimized results of the antenna are obtained. The main outer square strip is fed by the  $50\Omega$  microstrip feed line for the antenna excitation as shown the Fig. 4.3 (a).

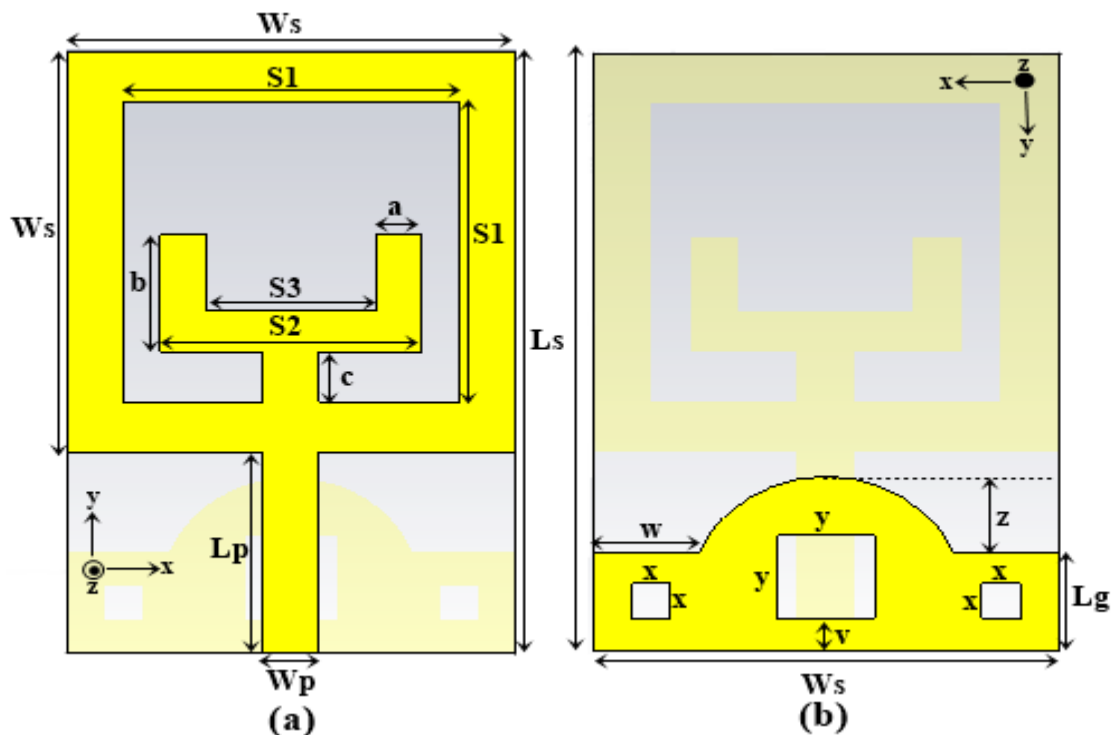

Fig. 4.3. (a) Front View of antenna (b) back view of antenna with all dimensions.

The partial (defected) ground plane i.e. printed on the back side of the antenna substrate comprises of the curved in shape. In addition to the curved shape, three square shape polygons have been also etched as defect in the ground plane as shown in the Fig. 4.3 (b). This defectiveness in the ground plane makes the antenna with defected ground structure. These defects are below the microstrip feed line that will changes its characteristics that will provides the good impedance matching with the improved bandwidth. The curved shape of defected ground plane and main radiating patch provides the three frequency bands required for the operation of the antenna for the WiMAX and WLAN applications.

**Table 4.3 Parameters of proposed Antenna 1**

Parameter	Value	Parameter	Value
Ws	24 mm	Ls	36 mm
S1	18 mm	S2	14 mm
S3	9 mm	Lp	12 mm
Wp	3 mm	Lg	6 mm
a	2.5 mm	b	7 mm
c	4 mm	v	2 mm
w	5.5 mm	x	2 mm
y	5 mm	z	4.5 mm

#### 4.3.2 Return loss and bandwidth of antenna

The simulated return loss versus frequency plot of this proposed antenna is shown in the Fig. 4.4. The return loss is calculated through the value of peak reflection coefficient at resonant frequencies below the -10 dB.

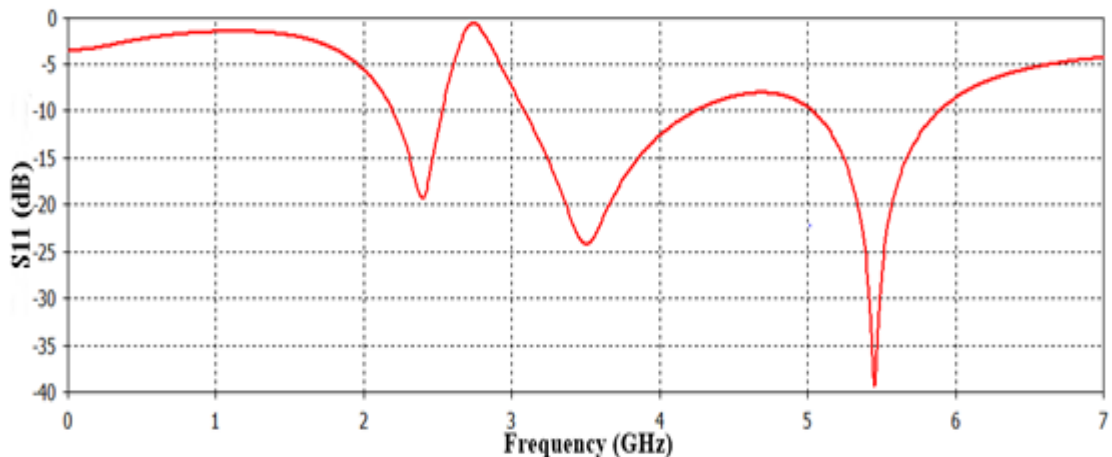

**Fig. 4.4. Return loss of antenna.**

It is obtained from this plot as shown in Fig. 4.4 that the peak return losses of antenna in three frequency bands are -19.33 dB at 2.4 GHz, -24.25 dB at 3.5 GHz and -39.5 dB at 5.5 GHz. More is the value of return loss in negative, better will be the impedance matching.

The bandwidth obtained is 0.33 GHz (2.20-2.53 GHz), 1.15 GHz (3.09-4.24 GHz) and 0.86 GHz (5.03-5.89 GHz) respectively.

#### 4.3.3 Efficiency of proposed antenna

The simulated result of total efficiency (linear) versus frequency plot of the proposed antenna is shown in the Fig. 4.5. The total efficiency is obtained through the multiplication of a constant factor with radiation efficiency. The efficiency of the antenna is the ratio of power radiated to the power given in the isotropic conditions.

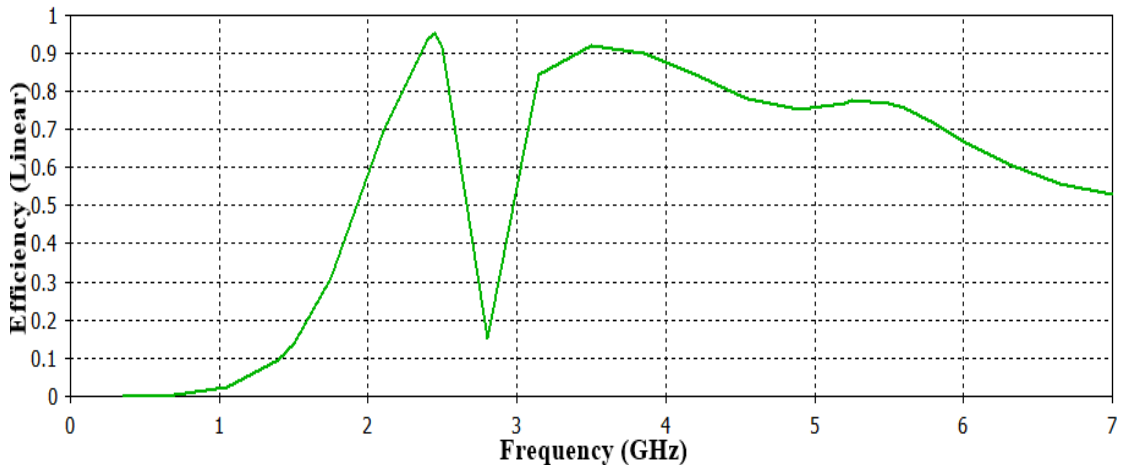
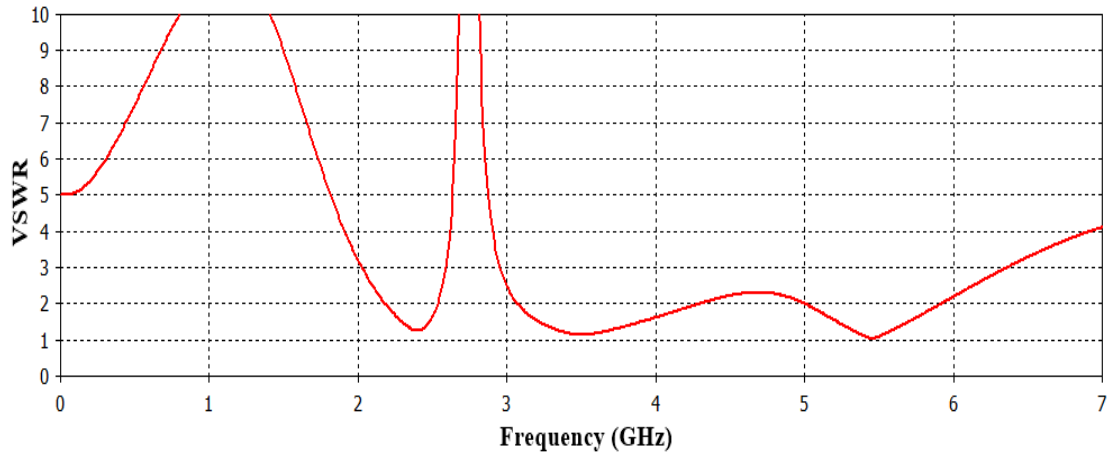

**Fig. 4.5. Efficiency of antenna.**

The total efficiencies shown by the proposed antenna are 95.16% at 2.45 GHz, 91.94% at 3.5 GHz, 76.84% at 5.2 GHz, 77% at 5.5 GHz and 71.47 % at 5.8 GHz. These efficiency values of proposed antenna are good for making the antenna practically for the WiMAX/ WLAN applications.

#### 4.3.4 VSWR of proposed antenna

In Fig. 4.6 the plot of voltage standing wave ratio (VSWR) versus frequency is shown. The transmitter and antenna both are connected through feed line, if there is impedance mismatching, then no proper energy transfer takes place and this will produce reflected waves that will leads to standing waves. Ideally VSWR should be between 1 and 2.

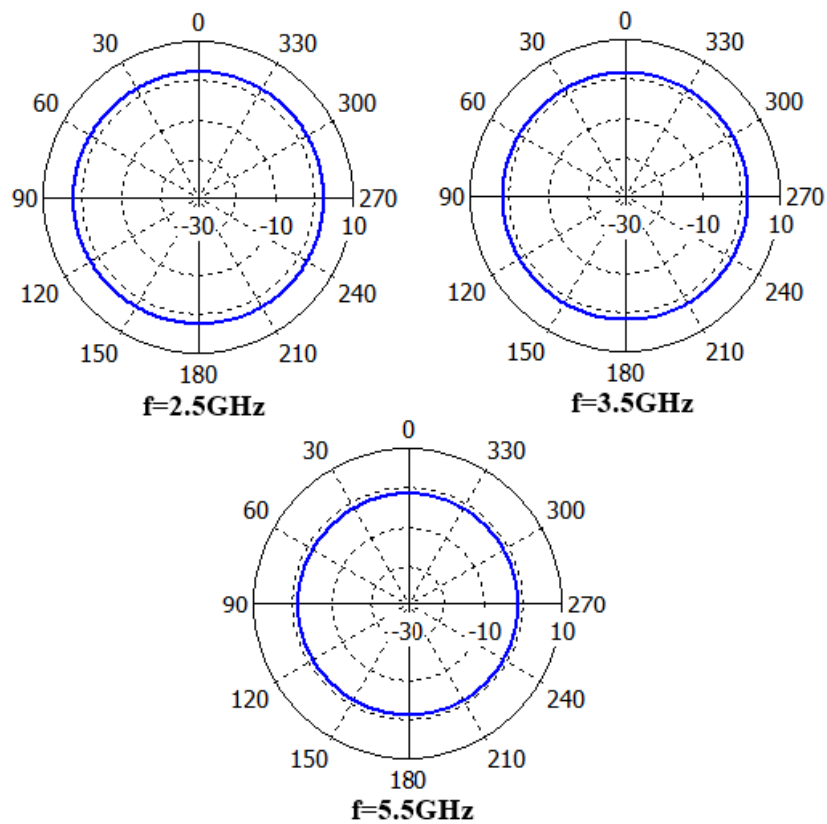

**Fig. 4.6 VSWR of antenna.**

This antenna is satisfying this criteria in all three required bands, having VSWR value between 1 and 2 that shows proper matching case.

#### 4.3.5 Radiation pattern of antenna in H-plane

The radiation pattern of the proposed patch antenna in H-plane (xz plane) is shown in the Fig. 4.7.

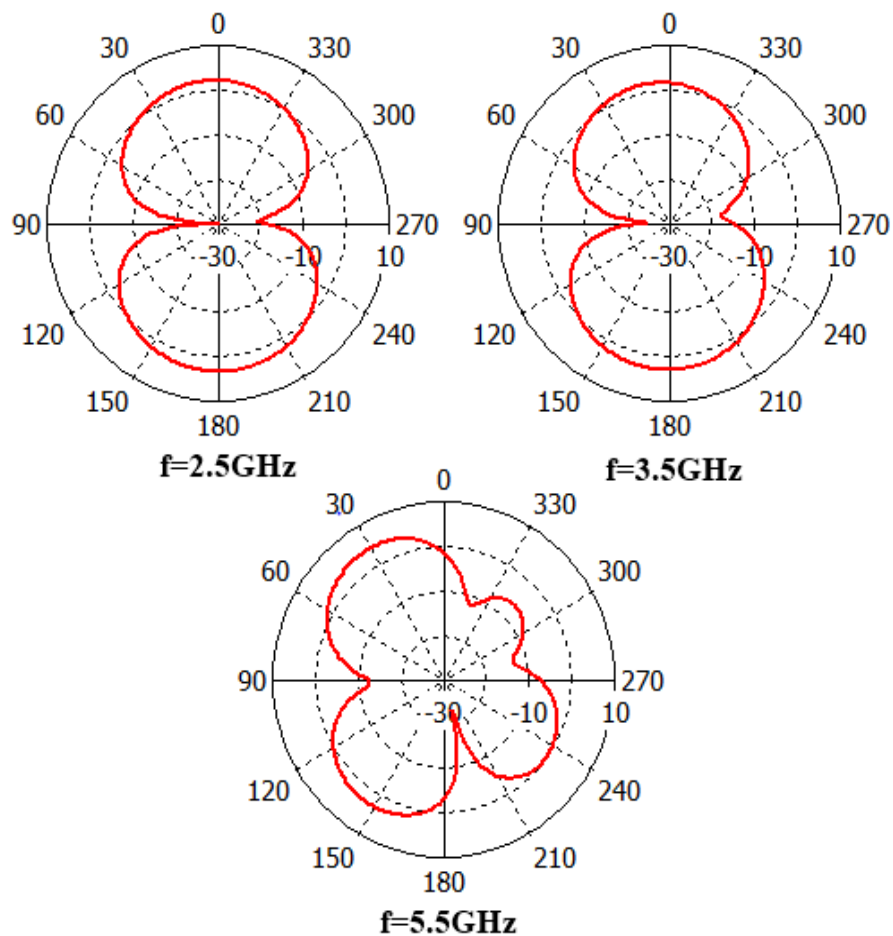

**Fig. 4.7. Simulated radiation pattern of antenna in H-plane.**

From this pattern in Fig. 4.7, it is demonstrated that the antenna has circular shape radiation pattern in H-plane displaying that the omni-directional pattern at all three frequencies i.e. 2.5 GHz, 3.5 GHz and 5.5 GHz required for the WiMAX and WLAN applications. It is calculated by keeping the  $\phi = 90^\circ$ .

#### 4.3.6 Radiation pattern of antenna in E-plane

The radiation pattern of proposed patch antenna in E-plane (yz plane) is shown in the Fig. 4.8.

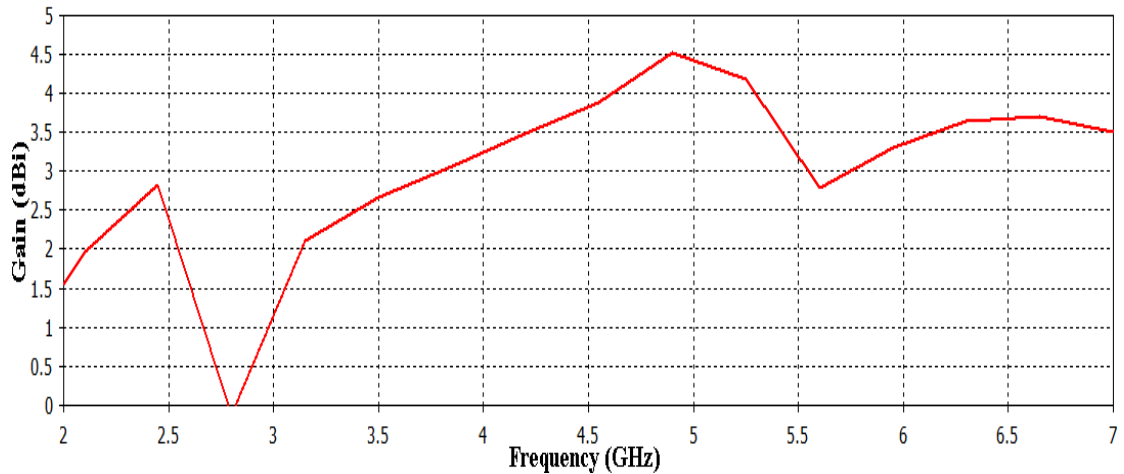

**Fig. 4.8. Simulated E-plane radiation pattern of antenna.**

It is illustrated from the figure that the antenna has good radiation pattern at frequencies 2.5 GHz and 3.5 GHz, having shape of mathematical letter ‘8’. It has somewhat distortion at higher frequencies as shown in the figure at 5.5 GHz, because at high frequencies there is generation of ripples give rise to directional pattern instead of omni-directional. At high frequency the stability of substrate also decreases that give rise to the ripples at high frequencies.

### 4.3.7 Gain (dBi) of antenna

This proposed antenna has high gain as shown in Fig. 4.9. The gain is calculated in dBi. In dBi, 'dB' stands for decibels and 'i' stands for isotropic conditions.



**Fig. 4.9. Gain vs frequency plot of antenna.**

The peak gains obtained through the simulation in three bands are 2.81 dBi (2.20-2.53 GHz), 2.65 dBi (3.09-4.24 GHz) and 4.38 dBi (5.03-5.89 GHz) respectively. This obtained gain is good for the WiMAX and WLAN applications.

### 4.3.8 Directivity of antenna

The power density radiated by an antenna in a particular direction is known as the directivity of antenna. The directivity of antenna at different frequencies is explained in the following section from the 3D view of radiation pattern.

#### At 2.5 GHz

The 3D overview of directivity plot at frequency 2.5 GHz is shown in the Fig. 4.10.

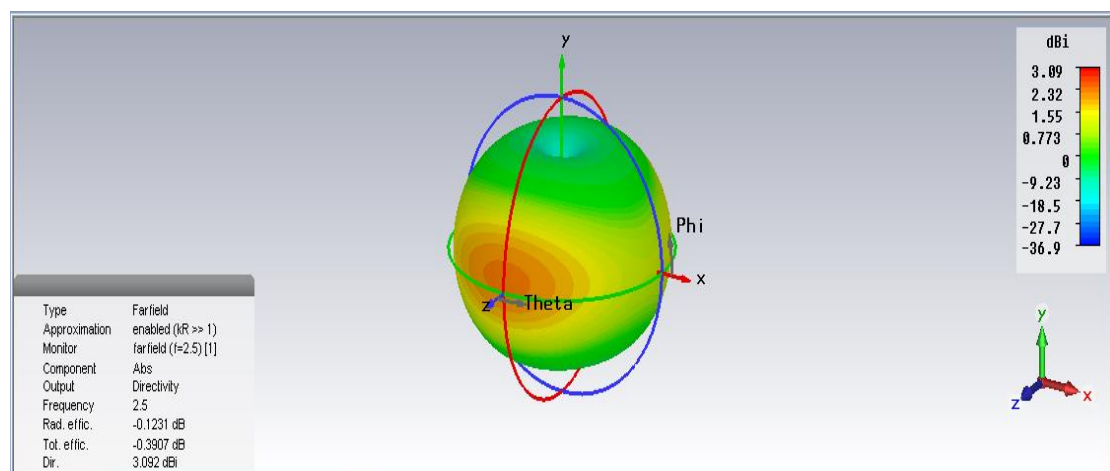
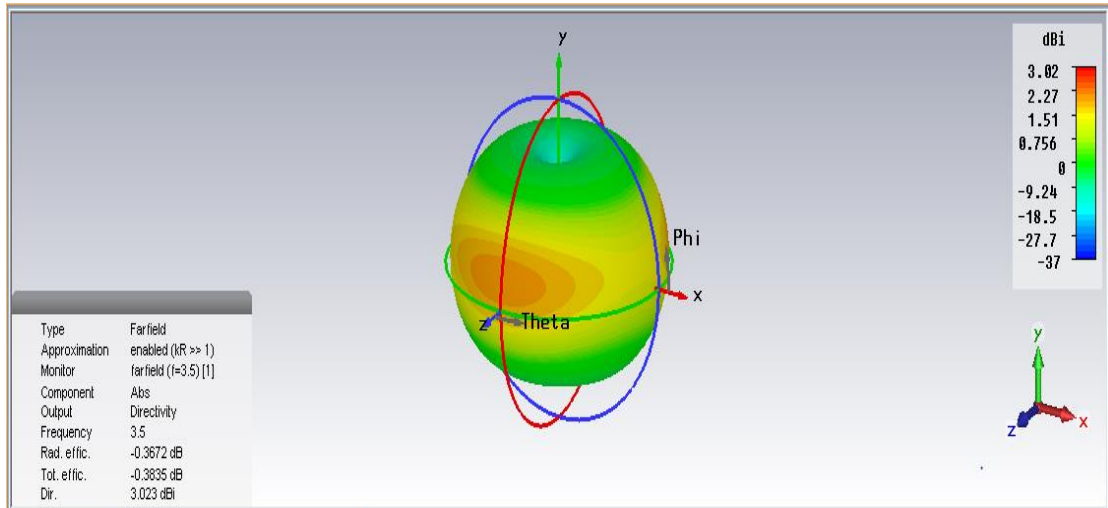

**Fig. 4.10. 3D radiation pattern of antenna at 2.5 GHz.**

The directivity of antenna at 2.5 GHz frequency is 3.092 dBi.

### At 3.5 GHz

The 3D overview of directivity plot at frequency 3.5 GHz is shown in the Fig. 4.11.

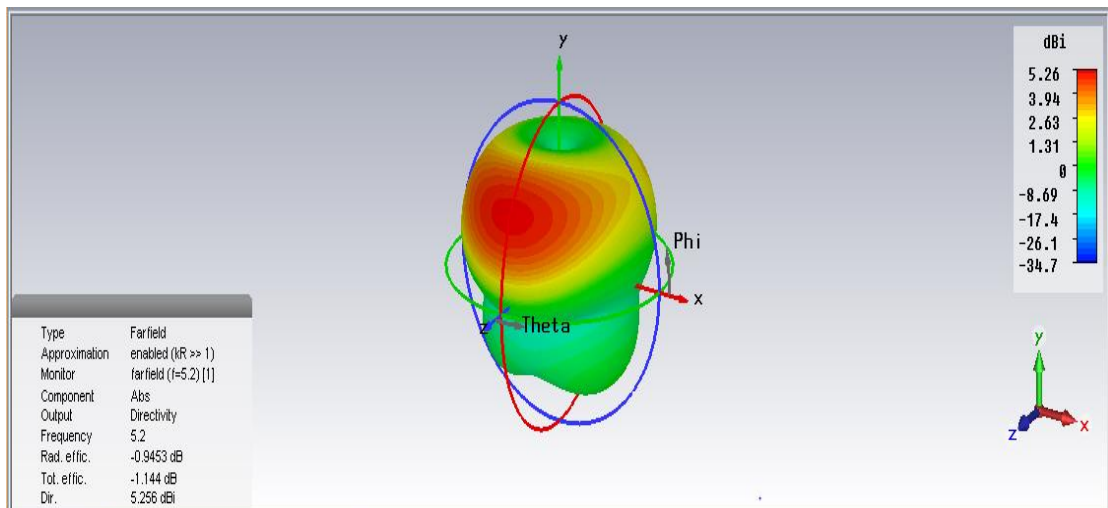

**Fig. 4.11. 3D radiation pattern of antenna at 3.5 GHz.**

The directivity of antenna at 3.5 GHz frequency is 3.023 dBi.

### At 5.2 GHz

The 3D overview of directivity plot at frequency 5.2 GHz is shown in the Fig. 4.12.

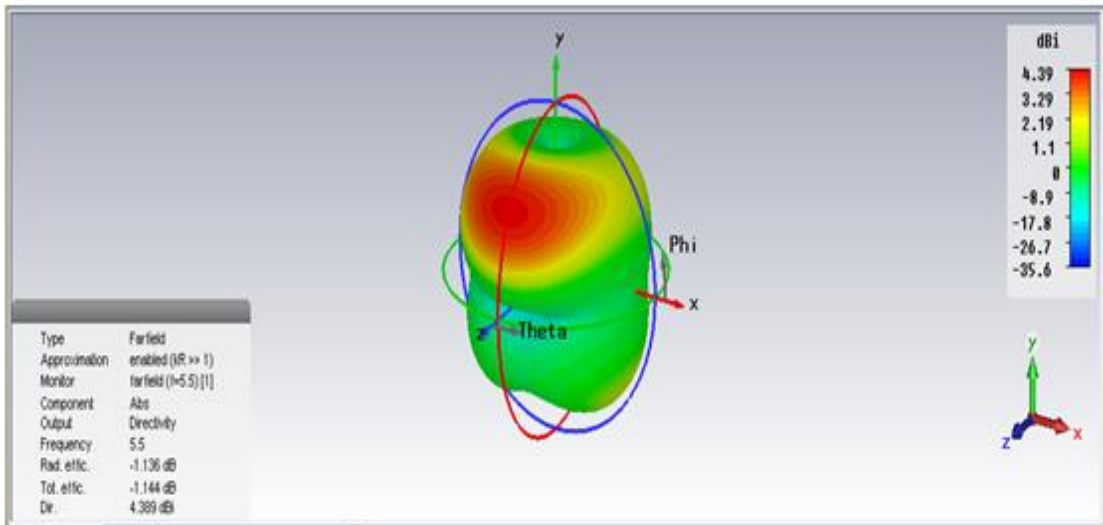

**Fig. 4.12. 3D radiation pattern of antenna at 5.5 GHz.**

The directivity of antenna at 5.2 GHz frequency is 5.256 dBi. At high frequencies antenna become more directional.

### At 5.5 GHz

The 3D overview of directivity plot at frequency 5.5 GHz is shown in the Fig. 4.13.

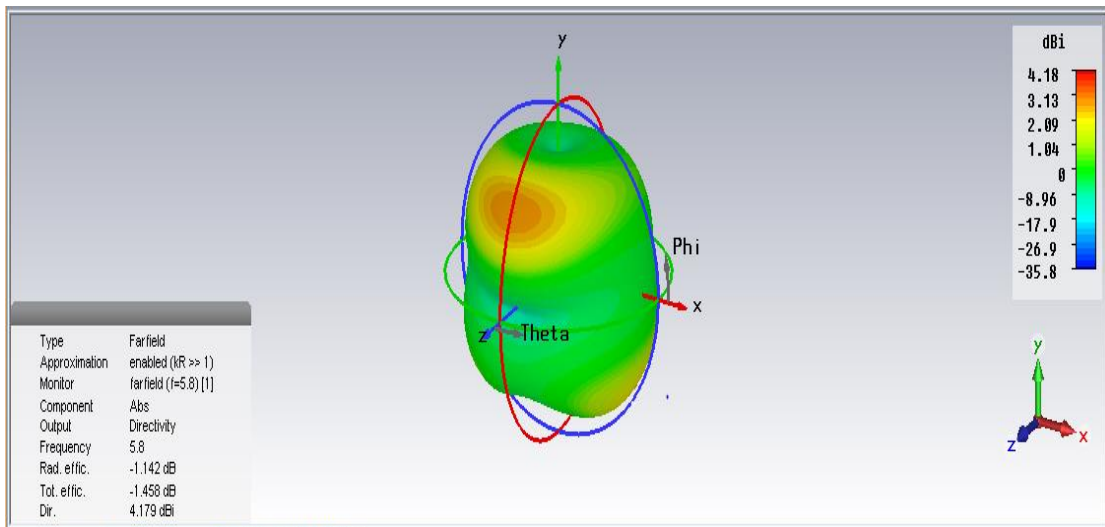

**Fig. 4.13. 3D radiation pattern of antenna at 5.5 GHz.**

The directivity of antenna at 5.5 GHz frequency is 4.389 dBi.

### At 5.8 GHz

The 3D overview of directivity plot at frequency 5.8 GHz is shown in the Fig. 4.14.

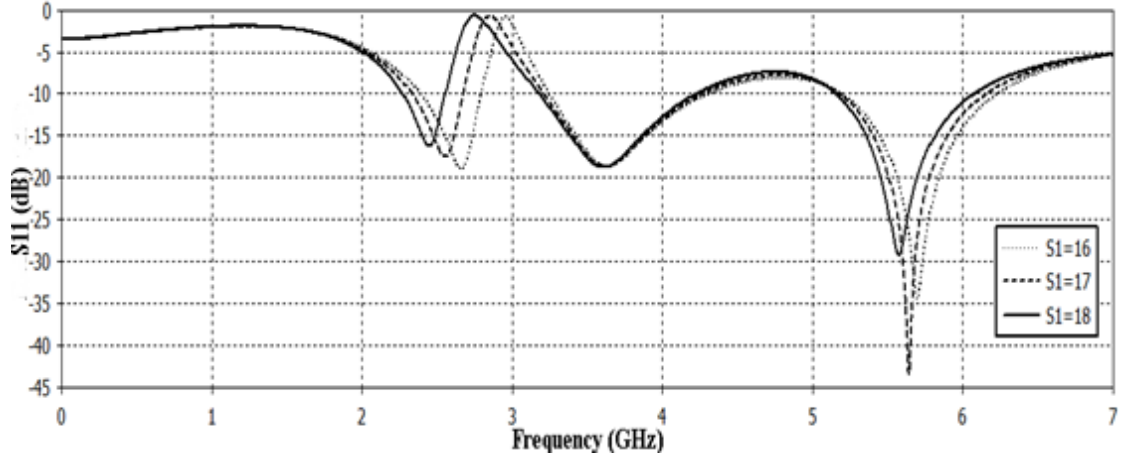

**Fig. 4.14. 3D radiation pattern of antenna at 5.8 GHz.**

The directivity of antenna at 5.8 GHz frequency is 4.179 dBi.

### 4.3.9. Comparison of return loss for variable parameter

The comparison of return loss is evaluated by changing the value of variable S1 as illustrated in the Fig. 4.15.



**Fig. 4.15. Comparison of return loss of antenna for variable parameters.**

As shown in the Fig. 4.15, that the return loss of the antenna changes by altering in the S1, but by this the other parameters also changes. As value of S1 decrease then the mutual coupling between outer square and the inner U shaped strip increases. So for the antenna to match the requirements of the mentioned wireless applications, we required optimized value of the S1. The optimized value of S1 is 18.

## 4.4 A Novel Design of Multiband DGS Based Microstrip Patch Antenna for WLAN/Wimax Applications (Antenna 2)

The suggested tri-band multi frequency antenna is shown in the Fig. 4.16, which is printed on the ROGER RO3003 with substrate of dimension  $37 \times 25 \text{ mm}^2$  with a thickness of 1.52 mm, having a relative permittivity ( $\epsilon_r$ ) of 3 and with a small tangent loss ( $\delta$ ) of 0.0013. The antenna substrate with low relative permittivity and more thickness provides the good efficiency, antenna performance and larger bandwidth [9].

### 4.4.1 Antenna design

The main patch element (radiating element) is printed on the top (front) side of the substrate consists of a Y-shape like metal strip surrounded by a circular ring shape metal strip. The patch elements are excited by an  $50\Omega$  impedance microstrip feed line of length 12.1 mm with a width 2.4 mm as shown in the Fig. 4.16 (a).

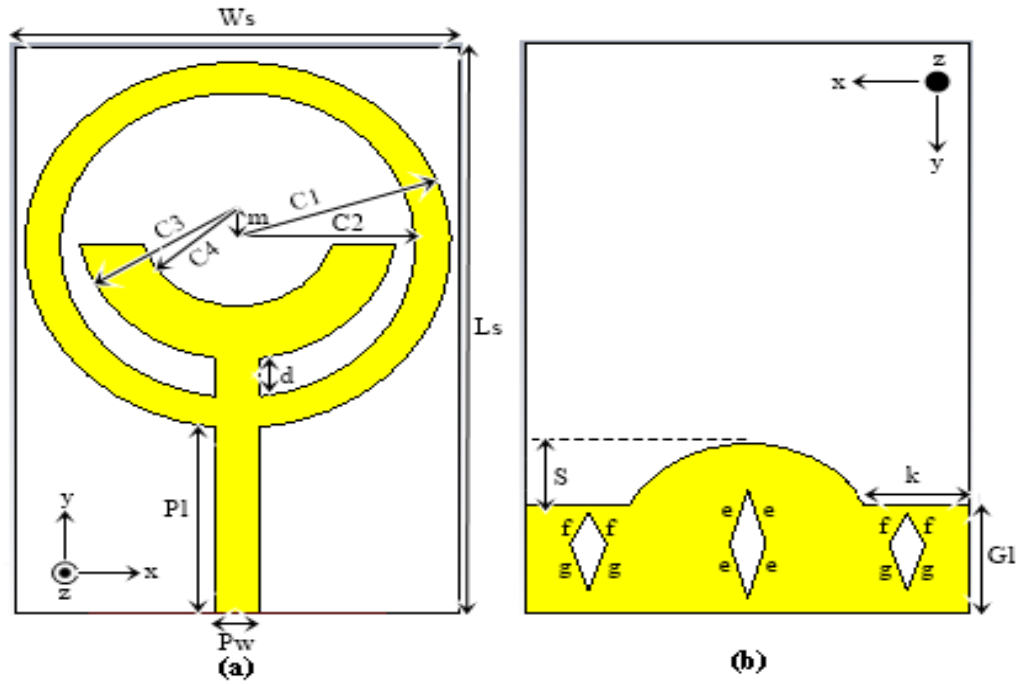

**Fig. 4.16. (a) Front (patch) view of antenna (b) Back (ground) of the antenna.**

The bottom (back) side of the antenna substrate be made up of a curved shape ground plane with mentioned dimensions. Three polygons of different shapes are etched in the ground plane for the defectiveness i.e. below the microstrip feed line as shown in the Fig. 4.16 (b). This will provide improved impedance matching, more bandwidth and improved efficiency. The different parameters with optimized value are as mentioned in Table 1 for the variables as shown in Fig. 4.16.

**Table 4.4. Parameters of proposed Antenna 2**

Parameter	Size	Parameter	Size
C1	12mm	C2	10mm
C3	9mm	C4	5.5mm
Ws	25mm	Ls	37mm
Gl	7mm	S	4mm
Pl	12.1mm	Pw	2.4mm
m	1.5mm	d	3.11mm
e	3.64mm	f	2.23mm
g	3.16mm	k	5.87mm

#### 4.4.2 Return loss and bandwidth of the proposed antenna

The simulated return loss versus frequency plot of this proposed antenna is shown in the Fig. 4.17. The return loss is calculated through the value of peak reflection coefficient at resonant frequencies below the -10 dB.

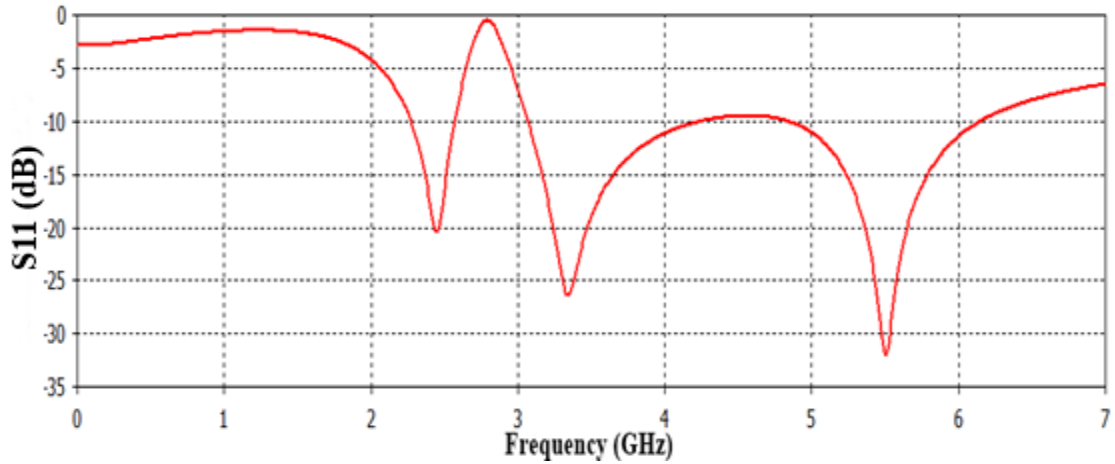

**Fig. 4.17. Simulated return loss vs frequency plot of antenna.**

From the simulation it is obtained that the return loss i.e. below -10 dB are about -20.41 dB at frequency 2.45 GHz, -26.42 dB at frequency 3.34GHz and -31.97 dB at frequency 5.5GHz respectively.

The bandwidth of three bands are 0.3GHz (2.27-2.57GHz), 1.17GHz (3.07-4.24GHz) and 1.302GHz (4.837-6.139GHz).

#### 4.4.3 Efficiency of antenna

The simulated result of total efficiency (linear) versus frequency plot of the proposed antenna is shown in the Fig. 4.18.

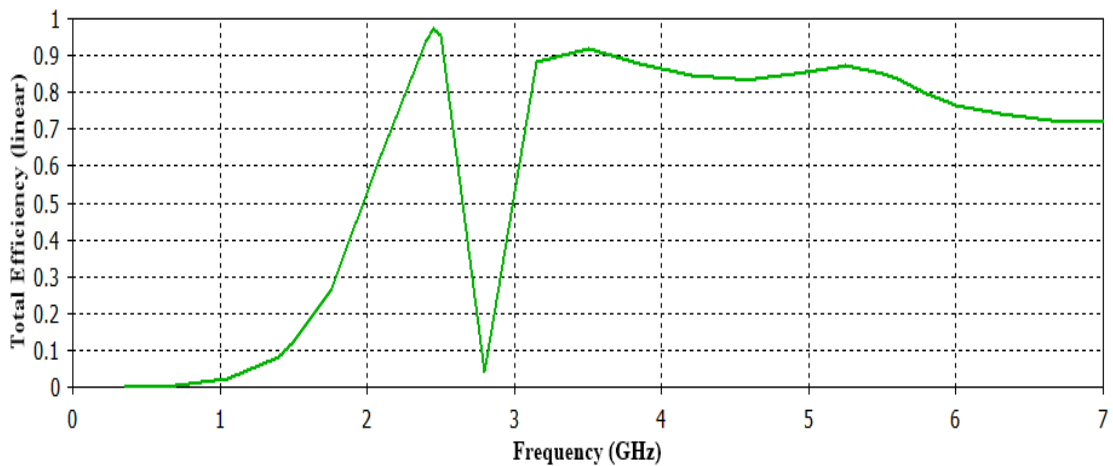
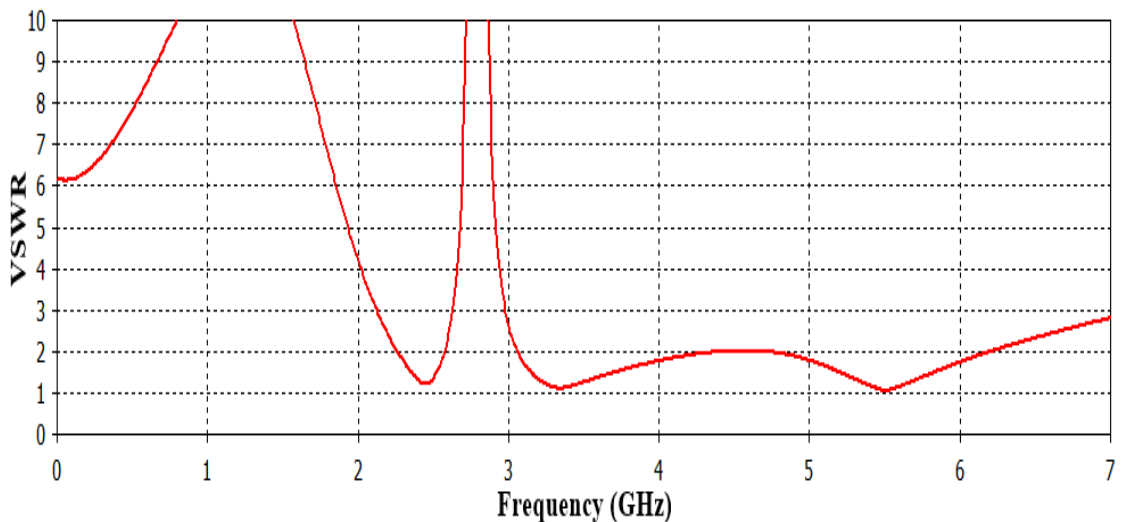

**Fig. 4.18. Simulated total efficiency vs frequency plot of antenna.**

The total efficiency is obtained through the multiplication of a constant factor with radiation efficiency. The efficiency of the antenna is the ratio of power radiated to the given power in the isotropic conditions. This plot in Fig. 4.18 shows that the efficiencies are 97.4% at 2.45 GHz, 91.97% at 3.5GHz, 87% at 5.2 GHz, 85.07% at 5.5GHz and 79.59% at 5.8GHz respectively. This antenna has efficient efficiency that to satisfy the practical considerations for the antenna fabrication.

#### 4.4.4 VSWR of proposed antenna

In Fig. 4.19 the plot of voltage standing wave ratio (VSWR) versus frequency is shown. The transmitter and antenna both are connected through feed line, if there is impedance mismatching, then no proper energy transfer takes place and this will produce reflected waves that will leads to standing waves. Ideally VSWR should be between 1 and 2. This antenna is satisfying this criteria in all three required bands i.e., band of 2.4/2.5 GHz, 3.5 GHz and 5.2/5.5/5.8 GHz having VSWR value between 1 and 2 that shows proper matching case.



**Fig. 4.19. Simulated VSWR vs frequency of antenna.**

#### 4.4.5 Radiation pattern of antenna in E-plane

The radiation pattern of proposed patch antenna in E-plane (yz plane) is shown in the Fig. 4.20.

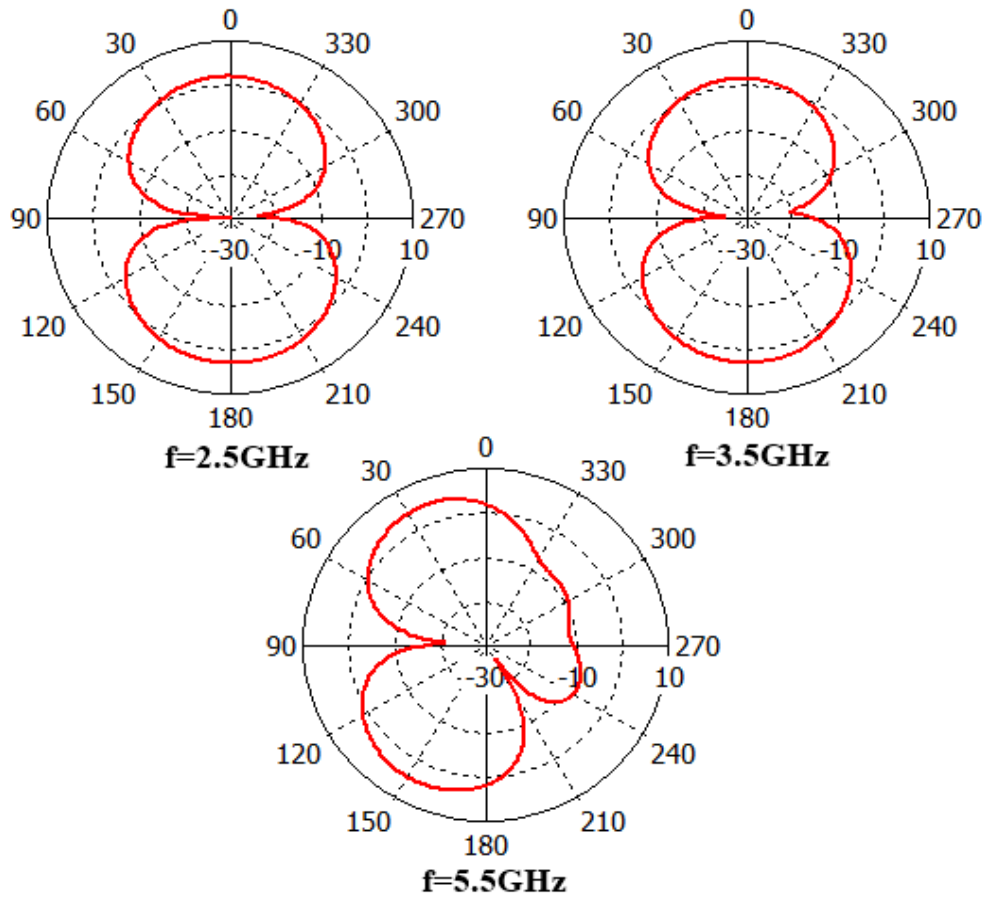

**Fig. 4.20. Simulated E-plane radiation pattern of antenna.**

It is illustrated from the figure that the antenna has good radiation pattern at frequencies 2.5 GHz and 3.5 GHz, having shape of mathematical letter ‘8’. It has somewhat distortion at higher frequencies as shown in the figure at 5.5 GHz, because at high frequencies there is generation of ripples give rise to directional pattern instead of omni-directional. At high frequency the stability of substrate also decreases that give rise to the ripples at high frequencies.

#### **4.4.6 Radiation pattern of antenna in H-plane**

The radiation pattern of the proposed patch antenna in H-plane (xz plane) is shown in the Fig. 4.21.

From this pattern in Fig. 4.21, it is demonstrated that the antenna has circular shape radiation pattern in H-plane displaying that the omni-directional pattern at all three frequencies i.e. 2.5 GHz, 3.5 GHz and 5.5 GHz required for the WiMAX and WLAN applications. It is calculated by keeping the  $\phi = 90^\circ$ .

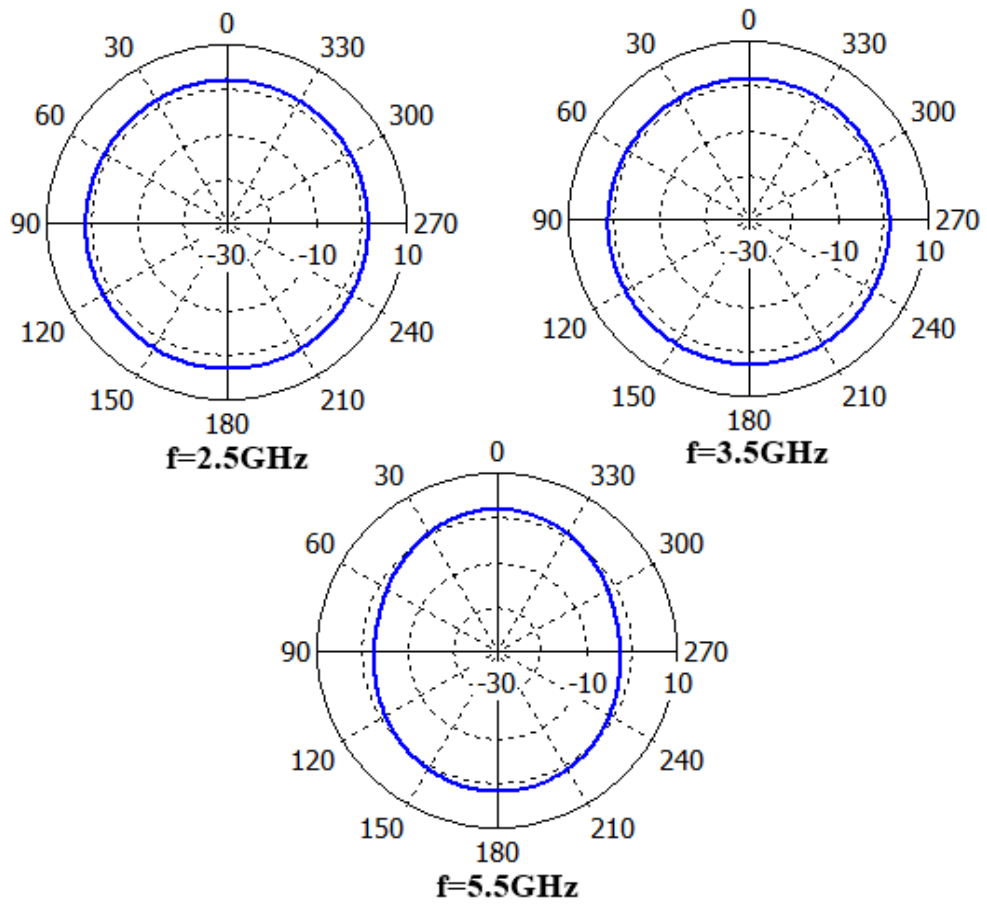

**Fig. 4.21. Simulated H-plane radiation pattern of antenna.**

#### 4.4.7 Gain of antenna

This proposed antenna has high gain as shown in Fig. 4.22. The gain is calculated in dBi. In dBi, ‘i’ stands for isotropic conditions. The more is the gain, more is the directivity of antenna.

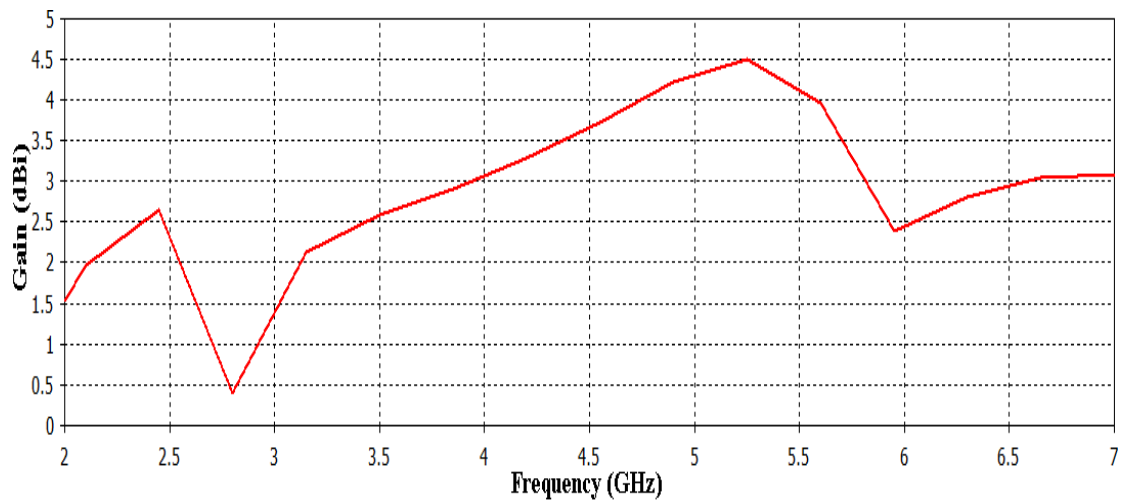

**Fig. 4.22. Simulated gain vs frequency plot of antenna.**

The isotropic peak gain for three bands is 2.66 dBi (2.27-2.57GHz), 2.58dBi (3.07-4.24) and 4.5 dBi (4.837-6.139GHz). Therefore the obtained values of the gain within three required bands of the suggested antenna successfully satisfies the requirements of WLAN and WiMAX wireless applications.

#### 4.4.8 Directivity of antenna

The power density radiated by an antenna in a particular direction is known as the directivity of antenna. The directivity of antenna at different frequencies is explained in the following section from the 3D view of radiation pattern.

##### At 2.5 GHz

The 3D overview of directivity plot at frequency 2.5 GHz is shown in the Fig. 4.23.

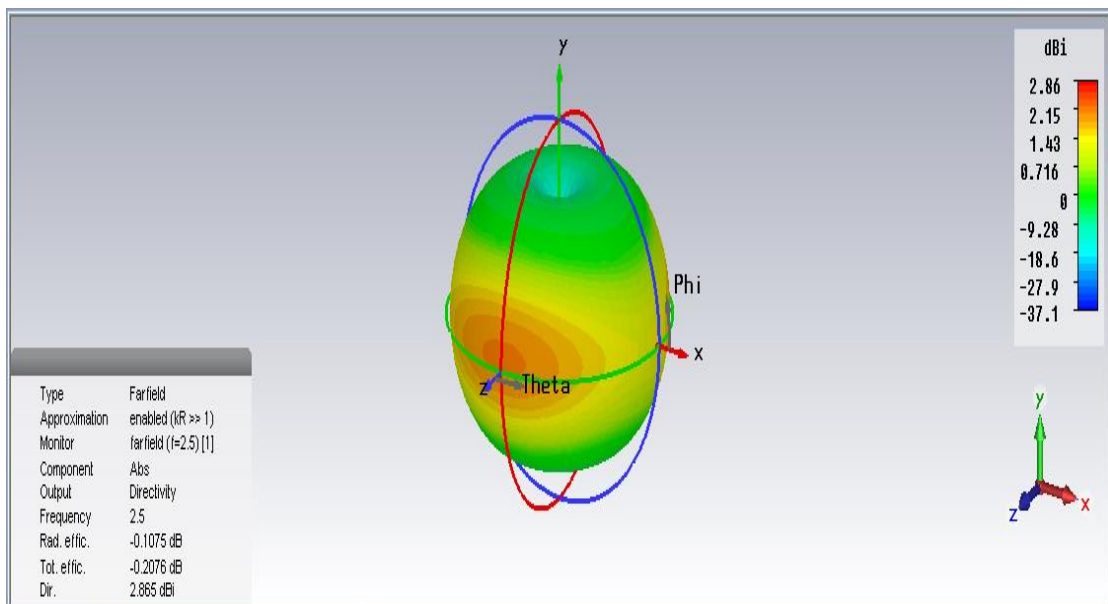
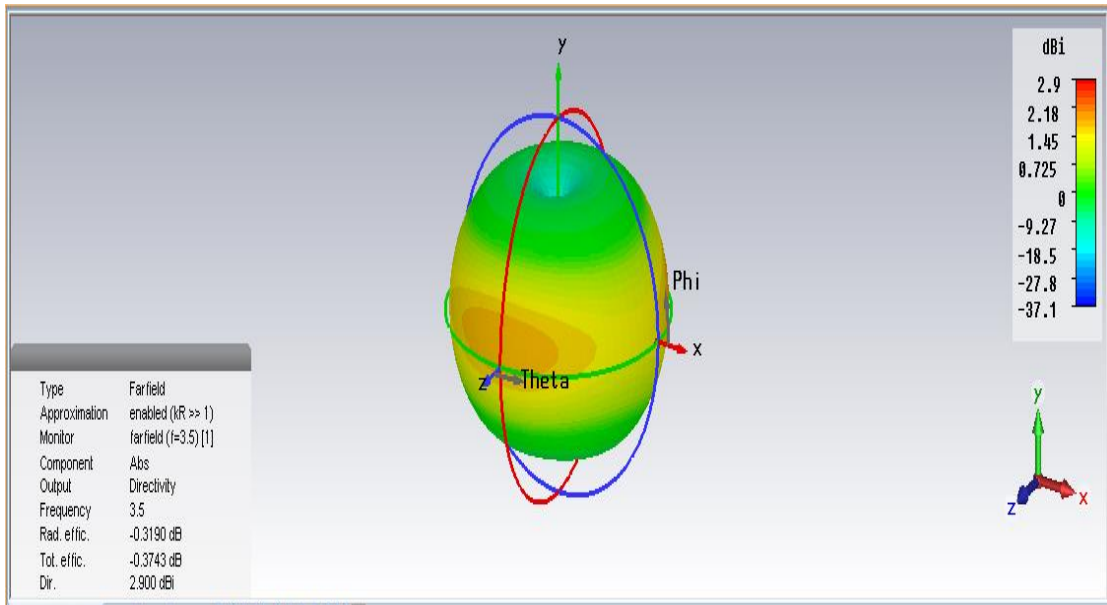

**Fig. 4.23. 3D radiation pattern of antenna at 2.5 GHz.**

The directivity of antenna at 2.5 GHz frequency is 2.865 dBi.

##### At 3.5 GHz

The 3D overview of directivity plot at frequency 3.5 GHz is shown in the Fig. 4.24.

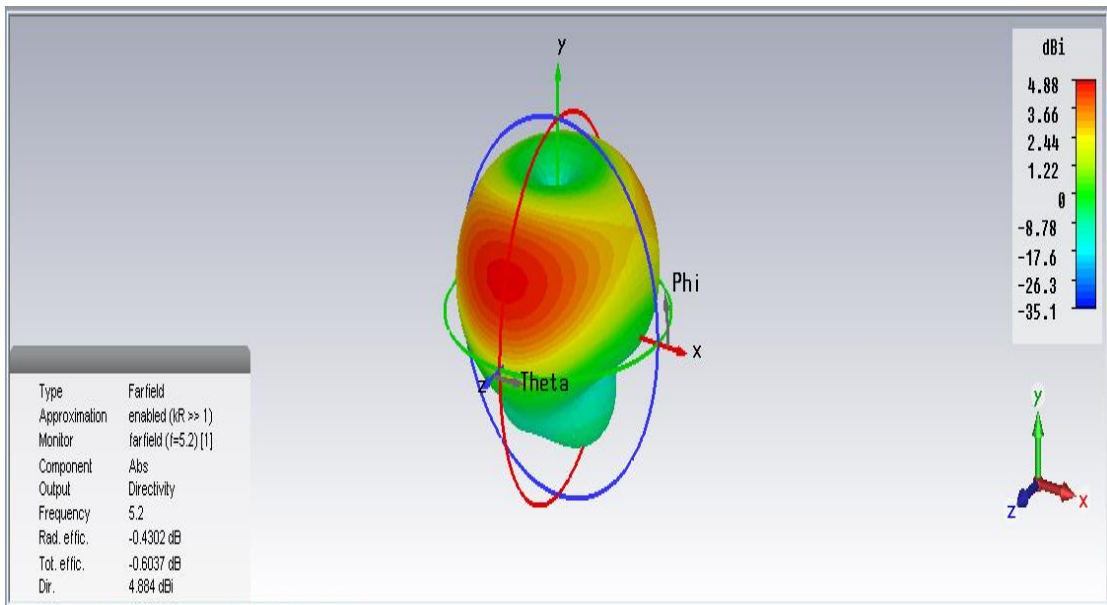

**Fig. 4.24. 3D radiation pattern of antenna at 5.5 GHz.**

The directivity of antenna at 3.5 GHz frequency is 2.900 dBi.

### At 5.2 GHz

The 3D overview of directivity plot at frequency 5.2 GHz is shown in the Fig. 4.25.

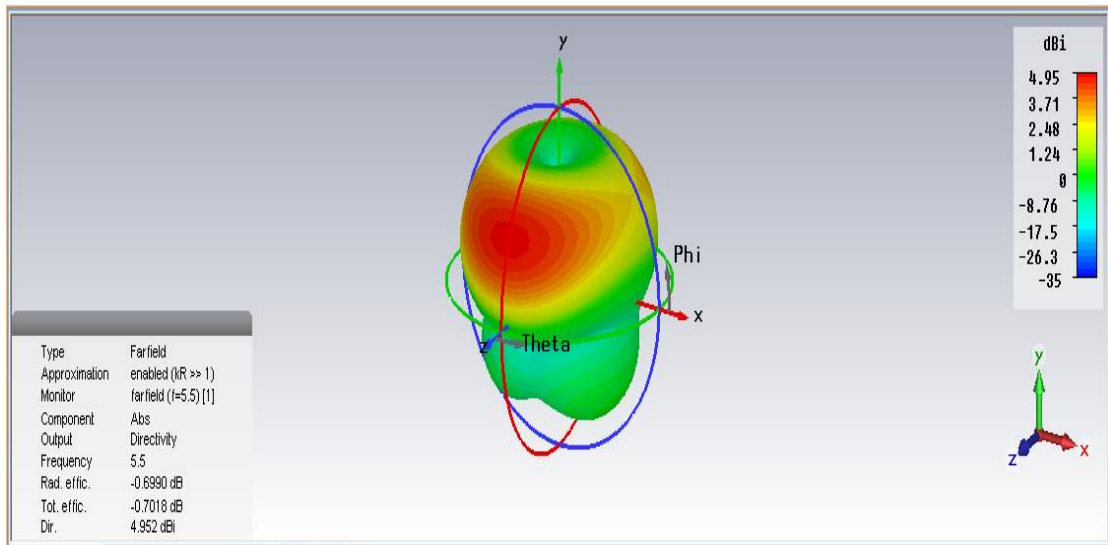

**Fig. 4.25. 3D radiation pattern of antenna at 5.2 GHz.**

The directivity of antenna at 5.2 GHz frequency is 4.884 dBi.

### At 5.5 GHz

The 3D overview of directivity plot at frequency 5.5 GHz is shown in the Fig. 4.26.

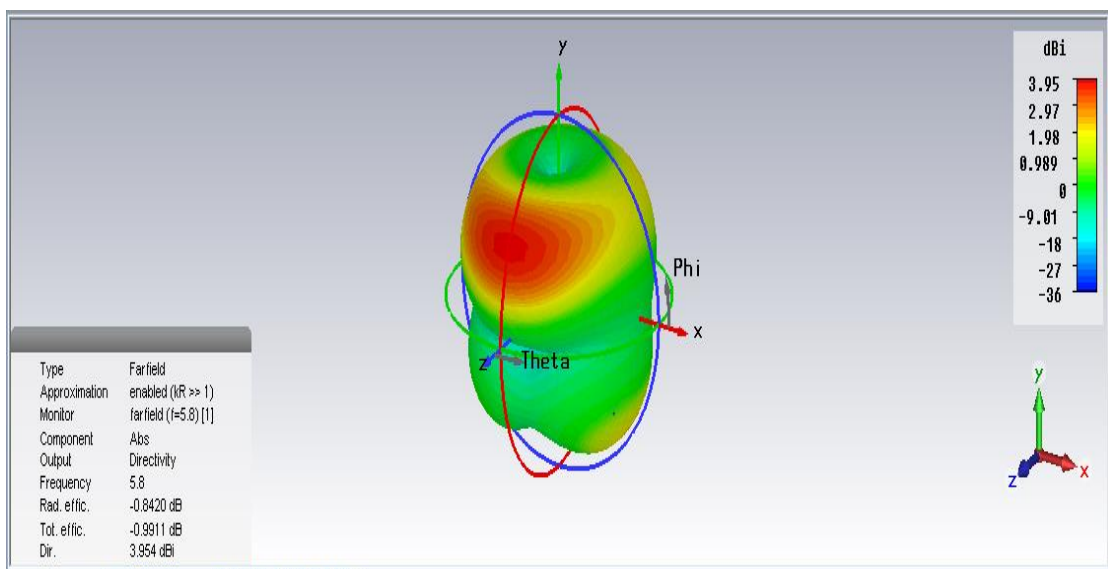

**Fig. 4.26. 3D radiation pattern of antenna at 5.5 GHz.**

The directivity of antenna at 5.5 GHz frequency is 4.952 dBi.

### At 5.8 GHz

The 3D overview of directivity plot at frequency 5.8 GHz is shown in the Fig. 4.27.



**Fig. 4.27. 3D radiation pattern of antenna at 5.8 GHz.**

The directivity of antenna at 5.8 GHz frequency is 3.954 dBi.

As at higher frequencies the directivity of antenna increases, therefore the antenna will start more radiating in a one particular direction.

#### 4.4.9 Comparison of return loss for variable parameter

By changing in the value of the parameter ‘S’, the change in the return loss of the antenna is observed by keeping all other parameters constant as shown in the Fig. 4.28.

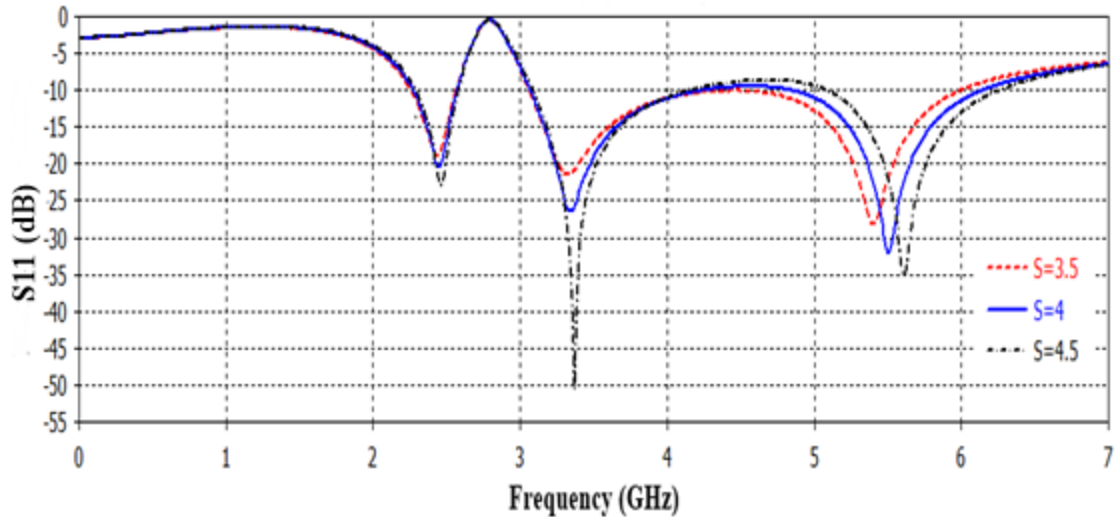
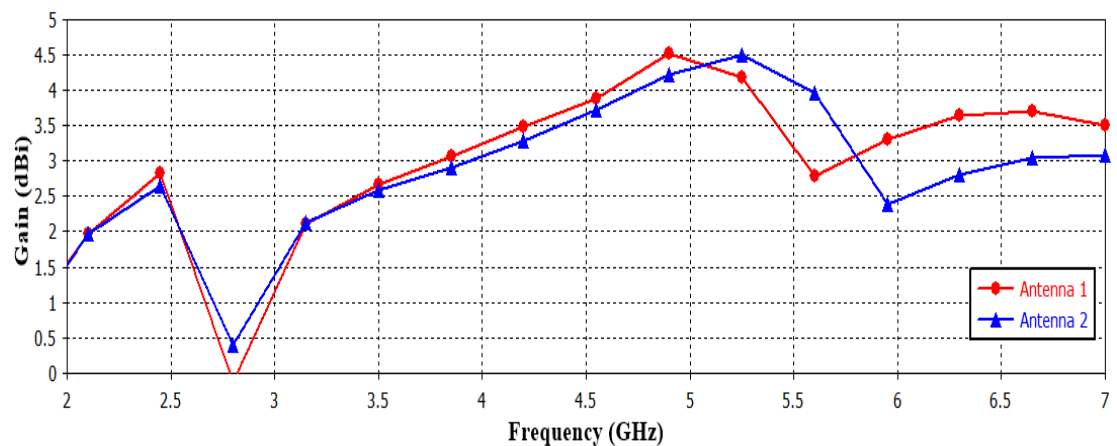

**Fig. 4.28. Return loss of antenna after changing parameters.**

The optimized return loss for the suggested antenna is observed at  $S=3.5$ ,  $S=4$  and  $S=4.5$ , out of these values of ‘S’, after studying the different parameters (like gain, efficiency etc.) the optimized value of ‘S’ is obtained as  $S=4$ . As seen from the Fig. 4.18. the effect changing parameter is mainly seen at the higher frequencies where the resonance frequency is shifted but the peak return loss is almost same. The return loss changes at the middle frequency.

#### 4.5 Comparison of Antenna 1 and Antenna 2

##### 4.5.1 Comparison of gain



**Fig. 4.29. Comparison of gain of Antenna 1 and Antenna 2.**

As shown in the Fig. 4.29 the Antenna 2 has higher gain in upper frequency operating band (peak 5.5 GHz) than Antenna1.

#### 4.5.2 Comparison of Efficiency

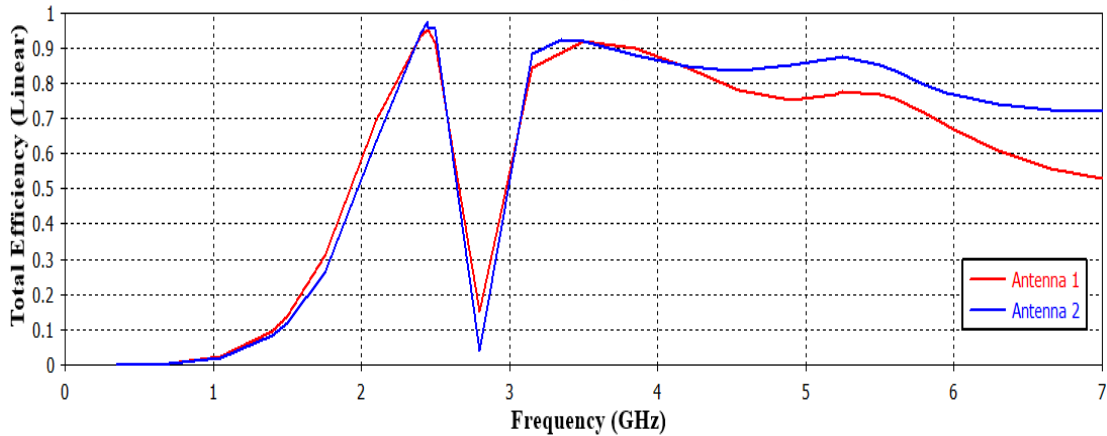

**Fig. 4.30 Comparison of efficiency of Antenna 1 and Antenna 2.**

As shown in the Fig. 4.30 the Antenna 2 has higher efficiency in upper frequency operating band (peak 5.5 GHz) than Antenna 1.

#### 4.5.3 Comparison of Side lobe level

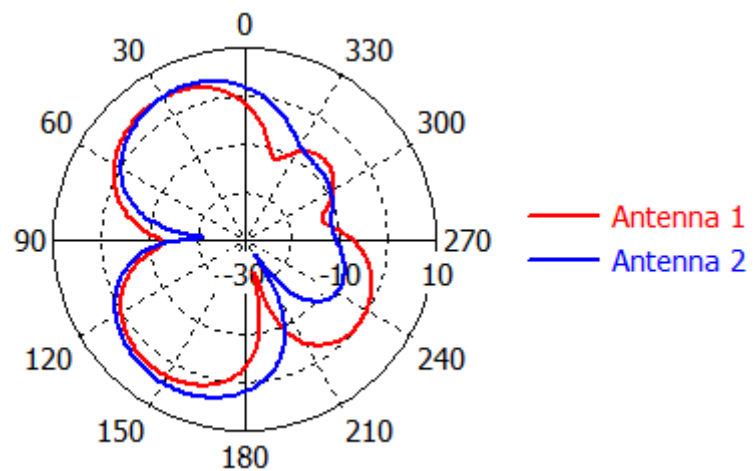

**Fig. 4.31. Comparison of side lobe level at f=5.5GHz of Antenna 1 and Antenna 2**

As shown in the Fig. 4.31. the side lobe level at f=5.5 GHz of Antenna 2 is less than the Antenna 1. Therefore the Antenna 2 has higher harmonic suppression phenomenon.

In terms of gain, efficiency and side lobe level, Antenna 2 has achieved better performance than Antenna 1, because square shape has more losses due to more edges. Hence Antenna 2 has been fabricated.

### ANTENNA FABRICATION & TESTING

---

*This chapter explains the antenna fabrication process and techniques. A low cost antenna fabrication technique has been discussed. Then the fabricated antenna is tested using VNA. A comparison of measured results of the fabricated antenna and simulated results is presented.*

---

#### 5.1 Antenna Fabrication Procedure

The steps of antenna fabrication are as following:

- 1) Obtain the optimized dimensions and design of the antenna using CST Microwave Studio<sup>®</sup>.
- 2) Make a layout of antenna design using Layout Plus OrCAD software or AutoCAD software.
- 3) Negative mask of antenna has developed and printed on the transparent sheet.
- 4) A properly cleaned double sided substrate of with copper cladding and of suitable dimension has been chosen.
- 5) Make a photo printing of patch, ground and microstrip feed line on the metals of substrate sheet using mask.
- 6) Then the PCB is dipped into the photoresist solution for the coating of negative photoresist material on the copper and put it into the oven for drying.
- 7) Expose the photoresist coated sheet to the UV light. It makes the exposed portion harder than the unexposed portions.
- 8) Then the sheet is dipped into the dark colour dye ink for the clear view of the hard portions of the copper cladding and then wash it with water.
- 9) The unwanted copper is etched by soaking the copper sheet into the Ferric Chloride (FeCl<sub>3</sub>) solution. The FeCl<sub>3</sub> dissolves the softer part of copper.
- 10) Finally the PCB is rinsed through the running water and we get the antenna of proper required dimensions successfully.

The whole defined process is known as the photo lithographic process of PCB fabrication.

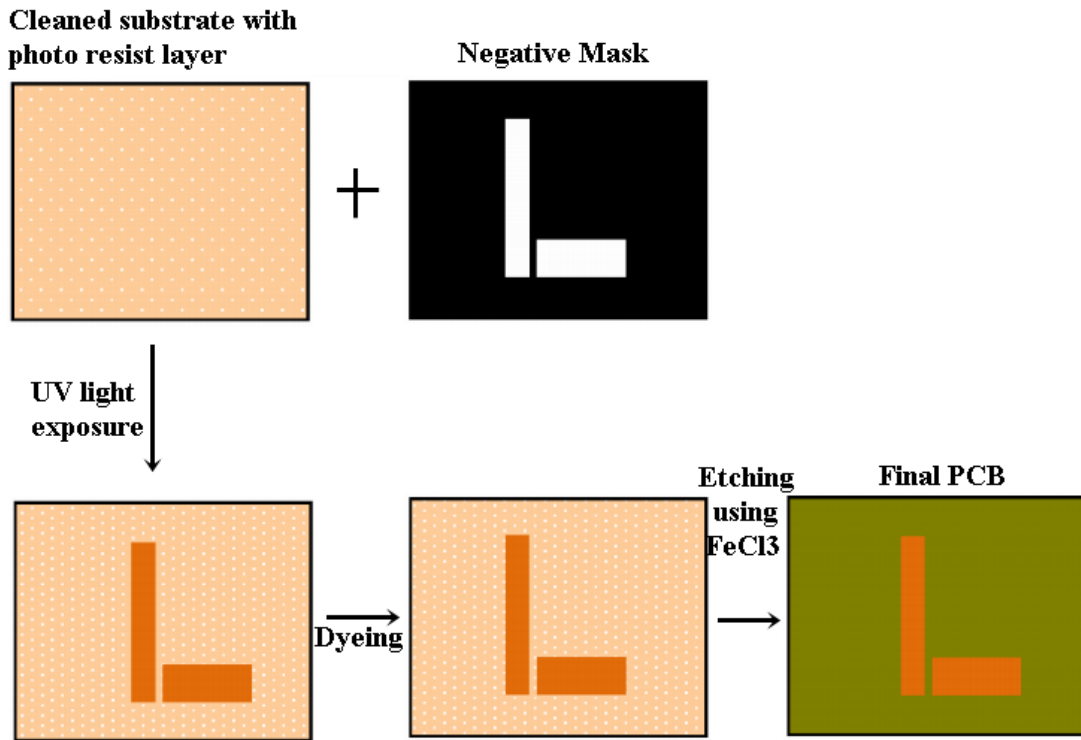

Fig. 5.1. Generalized PCB fabrication process [43].

## 5.2 Fabricated Antenna Design

Initially the negative mask for the antenna fabrication has been developed. The mask for the required antenna design is shown in the Fig. 5.2.

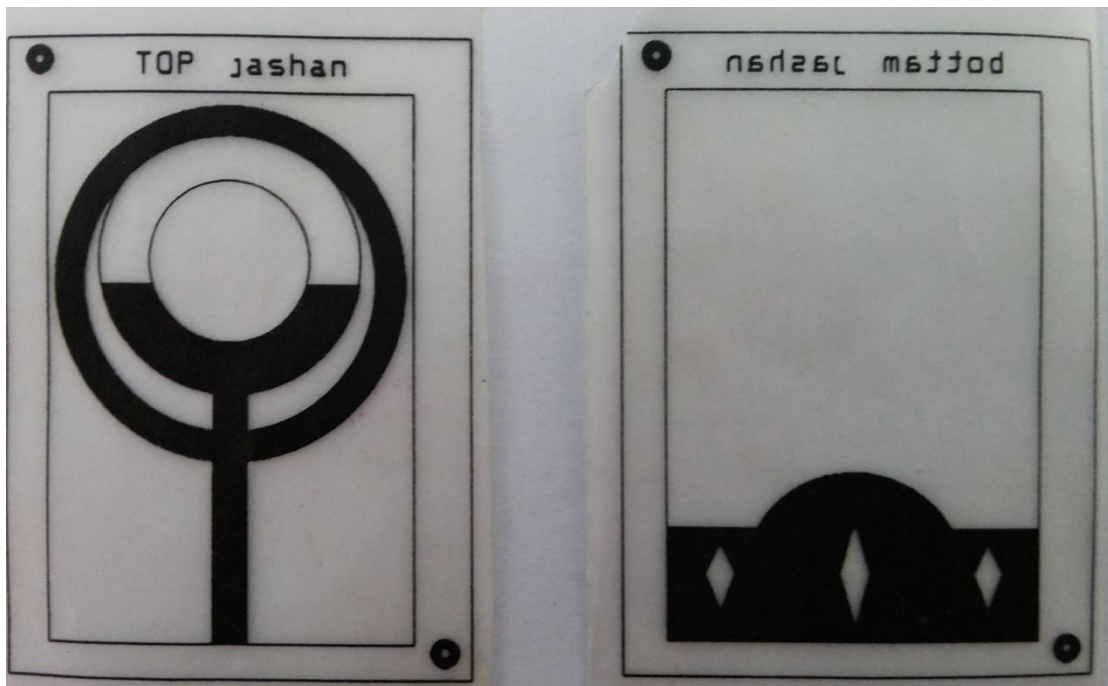

Fig. 5.2. Front (top) and back (bottom) view of negative of antenna design.

The photograph of fabricated antenna with SMA connectors is shown in the Fig. 5.3.



**Fig. 5.3. The photograph of top and back view of the fabricated antenna.**

The coin placed in Fig. 5.3 is for the size comparison of antenna, just as reference.

### **5.3 Antenna Testing using VNA**

The final fabricated antenna is tested with the aid of Vector Network Analyzer (VNA) of ANIRITSU Company's MS46322A model. This VNA has frequency range of 1MHz to 20 GHz. But for the practical consideration we have calculated the antenna return loss from 900 MHz to 7 GHz frequency band.

The antenna is connected through the VNA for excitation with the help of SMA connectors as shown by the photograph of VNA and antenna connection in Fig. 5.4.

The photograph of measured return loss of proposed antenna is shown in the Fig. 5.5.



**Fig. 5.4. Photograph of VNA and antenna connection.**



**Fig. 5.5. Photograph of measured return loss of proposed antenna.**

#### **5.4 Comparison of Measured and Simulated Return Loss**

The evaluation of the comparison between the measured and simulated return loss of the final fabricated antenna is shown in Fig. 5.6.

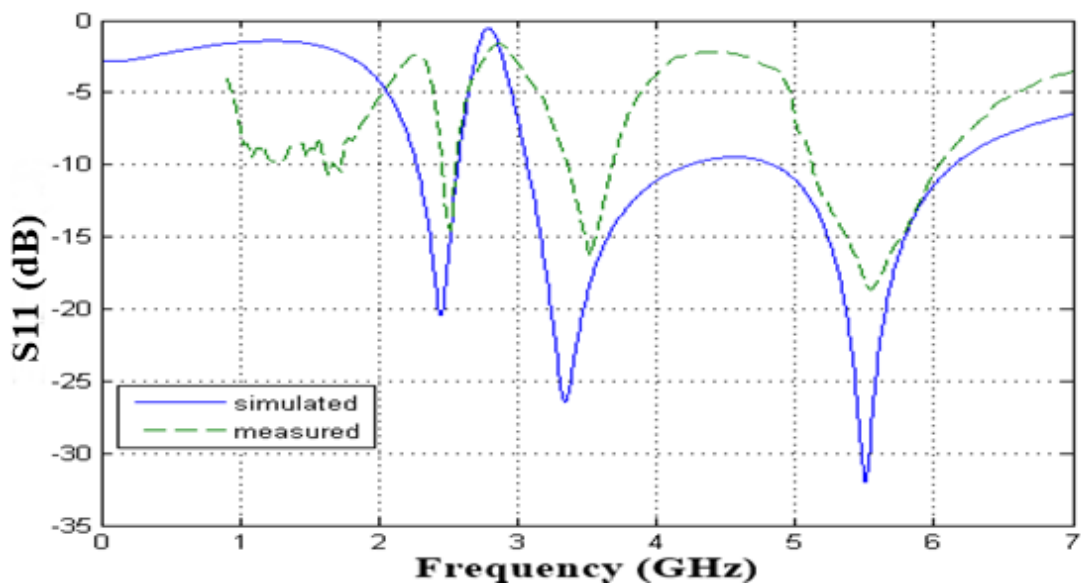

**Fig. 5.6. Comparison of measured and simulated return loss of antenna.**

The measured return loss plot starts from 900 MHz and ends at 7 GHz. Because practically it is not possible to test antenna starting from 0 Hz. The divergences between the measured and simulated return loss is due to the effect of the physical losses, these are may be for the reason that SMA connectors have some non-avoidable losses and also due to presence of non-ideal conditions of environment required for antenna testing. Due to very compact antenna size the coupling losses are also present between the various elements of antenna and connector may also affects the antenna performance. The losses are also present due to the measuring cable used for the antenna measurement system, as defined in [44].

### CONCLUSION & FUTURE SCOPE

---

#### 6.1 Conclusion

In this research work, the performance evaluation of two novel tri-band microstrip patch antennas (MPA) using defected ground structure have been done and is compared with the traditional antenna for the WiMAX/WLAN application in the bands of operation 2.5/3.5/5.5 GHz and 2.4/5.2/5.8 GHz respectively. First of all the conventional antenna has been simulated which is based on FR4 substrate and has circular shape patch enclosing a Y-shaped strip along with curved ground plane with a single defect of isosceles triangular shape. The numerous parameters of this antenna like gain, return loss, directivity, operating frequency and current distribution are simulated for the further designing of novel designs with improvement in the conventional design and is considered as the benchmark for rest of work. This conventional antenna has small bandwidth, low gain and less efficient because of presence of higher side lobe level at higher frequencies. These problems have been dealt with in this research work by designing two new MPA with different DGS structures and material of substrate.

The first antenna design proposed in this work is printed on ROGER RO3003 having square shape metal strip patch (radiating element) enclosing a U- shaped metal strip and having curved shape ground plane with three square shape ground defects of different dimensions. The peak return losses obtained of this antenna in three frequency bands are -19.33 dB at 2.4 GHz, -24.25 dB at 3.5 GHz and -39.5 dB at 5.45 GHz. The bandwidth obtained is 0.33 GHz (2.20-2.53 GHz), 1.15 GHz (3.09-4.24 GHz) and 0.86 GHz (5.03-5.89 GHz) respectively. The peak gains obtained in three operating frequency bands are 2.81 dBi, 2.65 dBi and 4.38 dBi respectively. The return loss of antenna has been evaluated for different dimensions to optimize the proposed antenna dimensions. This antenna has smaller size, higher gain, better efficiency, large bandwidth and more harmonic suppression at higher frequencies as compared to the conventional antenna.

The second antenna design printed on ROGER RO3003 having Y-shaped metal strip enclosed by a circular shape metal strip and curved shape ground with three polygon defects of different shape and dimensions are etched from the ground plane. The peak

return losses obtained from this antenna are -20.41 dB at 2.45 GHz, -26.42 dB at 3.34GHz and -31.97 dB at 5.5GHz respectively. The bandwidth of three bands are 0.3GHz (2.27-2.57GHz), 1.17GHz (3.07-4.24GHz) and 1.302GHz (4.837-6.139GHz). The isotropic peak gains of three bands are 2.66 dBi, 2.58dBi and 4.5 dBi. The effects of changing the dimensions of the curved shape of ground plane on the antenna performance have also been evaluated. The gain achieved of said design for all three bands made it good for WLAN and WiMAX wireless applications.

Both antennas have achieved better performance than conventional antenna because of change in substrate material, antenna dimension and shape of antenna. In comparison of first and second antenna, the second antenna has better antenna performance than first antenna. The second antenna has higher total efficiency and better harmonic suppression at higher frequencies which leads to minimization of side lobe level. Henceforth, the second antenna design is fabricated and tested. The comparison of experimental and simulated results of said antenna has been presented.

## **6.2 Future Scope**

- In future other feeding techniques such as coaxial probe feed, proximity coupled feed, aperture coupled feed CPW feeding techniques can also be used to design these type of antennas to achieve better performance.
- Polarization at each band can be studied further to remove the side lobes. The opportunity for commercialization of antenna for uses in wireless systems can be explored.
- Radiation pattern can be configured as desired by emerging technologies e.g. 5G.
- Reconfigurability can be included by adding switches for the different applications and for different frequency bands.

## REFERENCES

---

- [1] A. Goldsmith, *Wireless Communication*, 2nd ed. West 20th Street, NY: Cambridge University Press, 2005.
- [2] T. S. Rappaport, *Wireless Communication*, 3rd ed. Upper Saddle River, NJ:Prentice Hall, 1996.
- [3] M. M. U. I. Mir and D. S. Kumar, "Evolution of mobile wireless technology from 0G to 5G," *International Journal of Computer Science and Information Technologies*, vol. 6, no. 3, pp. 2545-2551, 2015.
- [4] Y. Li and G. Cheng, "Fourth generation wireless communication network," in *IEEE International Conference on Consumer Electronics, Communication & Networks*, Xianning, 2013.
- [5] M. R. Bhalla and A. V. Bhalla, "Generations of mobile wireless technology: A Survey," *International Journal of Computer Applications*, vol. 5, no. 4, pp. 26-32, 2010.
- [6] Y. Yeh and J. C. Chen, "WLAN standards," *IEEE Potentials*, vol. 22, no. 4, pp. 16-22, 2003.
- [7] K. H. Teo, T. Zhifeng, and J. Zhang, "The mobile broadband WiMAX standard," *IEEE Signal Processing*, vol. 24, no. 5, pp. 144-148, 2007.
- [8] K. Luk, "The importance of the new developments in antennas for wireless communication," *IEEE Proceedings*, vol. 99, no. 12, pp. 2082-2084, 2011.
- [9] C. A. Balanis, *Antenna Theory Analysis and Design*, 3rd ed. Ansari Road, ND: John Wiley and Sons, 2005.
- [10] K. Carver and J. Mink, "Microstrip antenna technology," *IEEE Transaction on Antenna and Propagation*, vol. 29, no. 1, pp. 2-24, 1981.
- [11] J. James, "What's new in antenna," *IEEE Antennas & Propagation magazine*, vol. 32, no. 1, pp. 6-18, 1990.

- [12] C. Peixeiro, "Microstrip patch antenna an historical perspective of the development," *IEEE Conference Publication*, pp. 684-688, 2011.
- [13] D. M. Pozar, "Microstrip antennas," *IEEE Proceedings*, vol. 80, no. 1, 1992.
- [14] R. Poisel, *Antenna System and Electronic Warfare Applications*, 685 Canton street, Norwood: Artech House, 2001.
- [15] M. Bugaj, R. Przesmycki, L. Nowosielski, and k. Piwowarczyk, "Analysis of different methods of microstrip antennas feeding for their electrical parameters," *PIERS Proceedings*, Malaysia, 2012.
- [16] A. Mandal, A. Ghoshal, A. Majumdar, A. Ghaosh, A. Das, and S. Das, "Analysis of feeding techniques of rectangular microstrip antenna," *IEEE International Conference*, Hong Kong, 2012.
- [17] G. Singh and J. Singh, "Comparitive analysis of microstrip patch antenna with different feeding techniques," *IJCA*, no. 7, pp. 18-22, 2012.
- [18] A. Elrashidi, K. Elleithy, and H. Bajwa, "The fringing field and resonance frequency of cylindrical microstrip printed antenna as a function of curvature," *Internatinal Journal of Computer Networks & Communication(INCNC)*, 2011.
- [19] S. Sankaralingam and B. Gupta, "Determination of dielectric constant of fabric materials and their use as substrates for design and development of antennas for wearable applications," *IEEE Transaction on Instrumentation and Measurements*, vol. 59, no. 12, pp. 3122-3130, 2010.
- [20] K. Rop and D. Konditi, "Performance analysis of microstrip patch antenna on different dielectric substrates," *IJJSE*, vol. 3, no. 8, pp. 7-15, 2012.
- [21] A. Tinoco S., D. Nascimento, and J. Lacava, "Rectangular microstrip antenna design suitable for undergraduate courses," *IEEE Antenna and Propaagtion Symposium*, San Deigo, CA, 2008.

- [22] M. Kara, "Effects of substrate thickness on the properties of rectangular microstrip antenna elements," *IEEE Microwave Propagation*, vol. 1, pp. 203-206, 1992.
- [23] T. Chang and J. Lin, "Enhanced return-loss and flat-gain bandwidths for microstrip patch antenna," *IEEE Transactions on Antennas and Propagation*, vol. 59, no. 11, pp. 4322-4325, 2011.
- [24] L. Weng, Y. Guo, X. Shi, and X. Chen, "An overview on defected ground structure," *Progress in Electromagnetics Research B*, vol. 7, pp. 173-189, 2008.
- [25] D. Guha, S. Biswas and C. Kumar, "Printed antenna design using defected Ground structures: a review of fundamentals and state-of-the-art developments," *Forum of Electromagnetic research methods and Application Technologies (FERMAT)*, pp. 1-3, 2009.
- [26] Y. Sung and Y. Kim, "An improved design of microstrip patch antennas using photonic bandgap structure," *IEEE Transaction on Antennas and Propagation*, vol. 53, no. 5, pp. 1799-1804, 2005.
- [27] C. Gar and M. Kaur, "A review of defected ground structure (DGS) in microwave design," *International Journal Of Innovative Research In Electrical, Electronics, Instrumentation And Control Engineering*, vol. 2, no. 3, pp. 1285-1290, 2014.
- [28] H. Singh, Y. Awasthi, and A. Verma, "Microstrip patch antenna with defected ground structure & defected microstrip structure," *IEEE International Conference on Microwave*, 2008.
- [29] H. Elftouh, N.A. Touhami, and M. Aghoutane, "Miniaturized microstrip patch antenna with defected ground structure," *Progress in Electromagnetic Research C*, vol. 55, pp. 25-33, 2014.
- [30] A. Arya, M. Kartikeyan, and A. Patnaik, "On the size reduction of microstrip patch antenna with defected ground structure," *IEEE Conference Publications*, Rome, 2010.

- [31] A. Arya, M. Kartikeyan, and A. Patnaik, "Efficiency enhancement of microstrip patch antenna with defected ground structure," *IEEE Conference Publications, Jaipur(India)*, 2008.
- [32] G. Kumar and K. P. Ray, *Broadband microstrip antennas*, 685 Canton street, Norwood: Artech House, 2003.
- [33] Q. Chu and L. Ye, "Design of compact dual-wideband antenna with assembled monopoles," *IEEE Transaction on Antenna and Propagation*, vol. 58, no. 12, pp. 4063-4066, 2010.
- [34] H. Liu, L. Shen, Z. Zhang, J. Lim, and D. Ahn, "Dual-mode dual-band bandpass filter using defected ground waveguide," *Electronics Letters*, vol. 46, no. 13, pp. 1-2, 2010.
- [35] H. Ding, "An ultra-compact dual-band antenna with tuning arms for WLAN applications," *Progress in Electromagnetic Research Letters*, vol. 21, pp. 109-117, 2011.
- [36] C. Huang and E. Yu, "A slot-monopole antenna for dual-band WLAN applications," *IEEE Antennas and Wireless Propagation Letters*, vol. 10, pp. 500-502, 2011.
- [37] R. L. Li, T. Wu, and M. M. Tentzeris, "A triple-band unidirectional coplanar antenna for 2.4/3.5/5-GHz WLAN/WiMAX applications," *IEEE Conference Publications, Charleston, SC*, 2009.
- [38] C. Kumar and D. Guha, "Defected ground structure (DGS)- integrated rectangular microstrip patch for improved polarisation purity with microstrip patch for improved polarisation purity with wide impedance bandwidth," *IET Microwave Antennas Propagation*, pp. 589-596, 2014.
- [39] X. Sun, J. Zhang, S. Cheung, and T. Yuk, "A triple band monopole antenna for WLAN and WiMAX applications," *IEEE Antennas and Propagation Society International Symposium (APSURSI)*, pp.1-2, 2012.

- [40] K. Thomas and M. Sreenivasan, "Compact triple band antenna for WLAN/WiMAX applications," *Electronics Letters*, vol. 45, no. 16, pp. 811-813, 2009.
- [41] F. Ren, F. Zahng, J. Bao, B. Chen, and Y. Jiao, "Compact triple-frequency slot antenna for WLAN/WiMAX operations," *Progress in Electromagnetics Research Letters*, vol. 26, pp. 21-30, 2011.
- [42] J. Pie, A. Wang, S. Gao, and W. Leng, "Miniaturized triple-band antenna with a defected ground plane for WLAN/WiMAX applications," *IEEE Antennas and Wireless Propagation Letters*, vol.10, pp. 298-301, 2011 .
- [43] D. A. Pucknell and K. Eshraghian, *Basic VLSI design: system and circuits*, Englewood Cliffs, NJ: Prentice Hall, 1990.
- [44] L. Liu, Y. Weng, C. S.W., T. Yuk, and L. Foged, "Modelling of cable for measurements of small monopole antennas," *IEEE Loughborough Antennas & Propagation Conference*, pp. 1-4, 2011.

## LIST OF PUBLICATIONS

---

- [1] Jashan Preet Singh and Ankush Kansal, "A novel microstrip patch antenna using square shapes ground defects for WiMAX/WLAN applications," *i-manager's Journal of Communication Engineering and Systems*, vol. 4, no. 2, pp. 28-33, Feb-April,2015.
- [2] Jashan Preet Singh and Ankush Kansal, "A novel design of multiband DGS based microstrip patch antenna," *Journal of Electromagnetic Waves and Applications*, communicated.