

**“Design of Ultrafast OTDM using Optical Delay Line Structure
Technique”**

*Dissertation submitted towards the partial fulfilment of requirement for the award of the
degree of*

Master of Engineering

in

Electronics and Communication Engineering

Submitted by:

Abhilasha Khare

(801261001)

Under the guidance of:

Dr. Hardeep Singh

(Assistant Professor)



**DEPARTMENT OF
ELECTRONICS AND COMMUNICATION ENGINEERING
THAPAR UNIVERSITY**

(Established under the section 3 of UGC Act, 1956)

PATIALA – 147004 (PUNJAB) July 2014.

DECLARATION

I, Abhilasha Khare, hereby declare that the work which is being presented in this dissertation entitled "Design of ultrafast OTDM using optical delay line structure technique" in partial fulfilment of the requirements for the award of degree of Masters of Engineering in Electronics and Communication engineering from Thapar University, Patiala, is an authentic record of my own work carried out under the guidance of Dr. Hardeep Singh. I have not submitted the matter presented in this dissertation in any other university/institute for the award of any other degree.

Date: 10-7-14

Abhilasha Khare.

Signature of student

Abhilasha Khare

Roll no.801261001

This is to certify that the above statement made by the student is correct to the best of my knowledge and belief.

Date: 10/7/14

HHH

Dr. Hardeep Singh

Assistant Professor, ECED

Thapar University, Patiala.

Countersigned by:

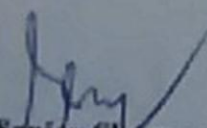
Dr. Sanjay Sharma
Professor and Head ECED,
Thapar University, Patiala

Date:

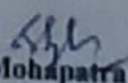
Dr. S.K. Mohapatra
Dean of Academic Affairs
Thapar University, Patiala.

Date:

ACKNOWLEDGEMENT

I would like to express my special thanks and deep sense gratitude to my dissertation advisor, Dr. Hardeep Singh, Assistant Professor, Electronics & Communication Engineering Department, Thapar University, Patiala for his continuous indefatigable guidance, which paved me on to the path to carry this project. He has always been very encouraging and offered invaluable advice. I am highly indebted to him for his painstaking efforts and invaluable suggestions during the period of work.

I am also thankful to **Dr. Sanjay Sharma**, Prof. & Head, Electronics and communication Engineering Department, for providing us with adequate infrastructure in carrying the work.

I am also thankful to **Dr. Kulbir Singh**, P.G. Coordinator, Electronics and communication Engineering Department for the motivation and inspiration that triggered me for the dissertation work.

I would also like to thank all the faculty members of ECED for their intellectual support and also special thanks to my friends who constantly encouraged me to complete this work. I am also thankful to the authors whose work I have consulted and quoted in this work.

Abhilasha Khare

Roll no.801261001

ABSTRACT

As high bandwidth applications continue to emerge, investigation in technologies that will increase transmission capacity becomes necessary. Several technologies have been investigated in recent years to satisfy this increased demand in bandwidth. Of these technologies, Optical Time Division Multiplexing (OTDM) has been presented as a possible solution, supporting a next generation high bit rate. OTDM has transmission advantages such as simultaneous dispersion compensation and regeneration of all channels, reduced requirements to erbium-doped fibre amplifier, gain flatness, and zero cross talk from four-wave mixing (FWM) or stimulated Raman scattering (SRS). Because of these factors OTDM is well suited for "backbone" networks with long spans and few nodes but is also being considered for ultrahigh-speed local area networks (LANs).

The present work aims at the designing, simulation and analysis of a structure of optical delay line based on packet interleaved OTDM. By varying various parameters such as bit rate (B), power required (P), extinction ratio, modulation formats etc analysis has been done for an optimum delay line and low propagation loss is realized. To demonstrate the capability of simultaneous packet compression and expansion optical packets with a bit rate of 1 Tb/s was taken and the setup was formed. A 1550nm continuous wave laser is used to generate optical pulses of power 0 decibels and line width 10MHz. A five stage fibre optic delay line is used ($n = 32$) for the expansion and compression of 32 bit data packets. An ODLS subsystem is created which is the packet compression stage. In the packet compression stage we have extensively concentrated our usage on power splitters and combiners. The packet after passing through each of compression stage is analysed separately to evaluate the packet compression and delay and is then amplified by the amplifier and optical band pass filter (BPF) in order to remove ASE (amplified spontaneous emission).

We also have investigated advanced intensity modulation formats of carrier suppressed return zero (CSRZ) and duo binary modulation formats. Their performance has been evaluated on the basis of their spectrum, BER curve and eye diagrams for fibre length of 50km. From the simulation results it is concluded that both modulation formats have their own advantages and their usage primarily depends upon the application they are used in.

Table of Contents

Declaration	i
Acknowledgement	ii
Abstract	iii
Table of Contents	iv
List of Figures	vi
List of Abbreviations	viii
List of Symbols	x
List of Tables	xi
1. Introduction	1
1.1 Motivation	1
1.2 Evolution of Optical Fiber Communication	1
1.2.1 Early Works	1
1.3 OTDM Transmission	5
1.4 OTDM Networking Prospects	8
1.5 OTDM Transmitter	11
1.6 OTDM Receiver	14
1.7 Transmission Line	17
1.8 Principle of OTDM	20
1.9 Generation and Detection of OTDM Data	21
1.10 Interleaving Stages	23
1.11 Bandwidth Requirements	24
1.12 OTDM Demultiplexing	24
1.12.1 Non-Linear Demultiplexing Setup	25
2.Literature Survey	28
2.1 Dissertation Scope	36
2.2 OptiSystem 7.0	36

2.2.1 Minimum System Requirements for OptiSystem	37
2.3 Objective of Dissertation	38
3. Design of Ultrafast OTDM using Optical Delay Line Structure	
Technique	
3.1 Introduction	40
3.2 Background	40
3.3 Proposed Optical Delay Line Structure	41
3.4 Simulation Setup	43
3.5 Results and Discussions	45
3.6 Conclusion	49
4. Performance Evaluation of CSRZ and Duo Binary	50
Modulation Format	
4.1 Introduction	50
4.1.1 Modulators	51
4.2 Intensity Modulation Formats	51
4.2.1 Carrier Suppressed Return Zero Modulation Format (CSRZ)	51
4.2.2 Duo Binary Modulation Format	52
4.3 Simulation Setup and Results	53
4.4 Conclusion	57
5. Conclusion and Future Scope	59
5.1 Conclusion	59
5.2 Future Scope	60
References	61

List of Figures

NO.	TITLE	PAGE NO.
1.1	Optical fiber communication system using repeaters	2
1.2	Demonstration of 160 Gb/s OTDM transmission system	7
1.3	Mode locked laser's pulse spectrum successfully demonstrated in 160Gb/s DPSK experiment	12
1.4	Schematic of Mach Zehnder Interferometer with semiconductor optical amplifier in both the arms of Interferometer	14
1.5	Schematic of SG-DBR-SOA-EAM	15
1.6	40Gbaud base rate demodulators for DPSK and DQPSK transmission	16
1.7	Schematic of an OTDM system	20
1.8	Time interleaving concept behind low baud rate channels	22
1.9	Generation of a 640 Gb/s PRBS signal	23
1.10	OTDM demultiplexing by non-linear sampling	25
1.11	Demultiplexing 640Gbaud or 1.28 Tbaud to 10 Gbaud tributary channels	26
2.1	Dissertation framework	39
3.1	Packet compressor/expander using ODLS	42
3.2	Block diagram for optical packet compression operation for 4 bit packet	44
3.3	Basic ODLS layout	44
3.4	Layout of compression subsystem	45
3.5(a)	Initial pseudo random bit sequence output	46
3.5(b)	Output after passing through first compression stage	47
3.5(c)	Output after passing through second compression stage	47
3.5(d)	Output after passing through third compression stage	48
3.5(e)	Output after passing through fourth compression stage	48
3.5(f)	Final compressed output after passing through fifth compression stage	49
4.1	Block diagram of CSRZ transmitter	51
4.2	Generation of duo binary modulation format	52
4.3	Layout of duo binary modulation format	54
4.4	Layout of CSRZ modulation format	54

4.5	Eye diagrams for (a) CSRZ, (b) Duo binary, modulation format	56
4.6	Quality factors of (a) CSRZ, (b) Duo binary, modulation format	56
4.7	Spectrum of (a) Duo binary, (b) CSRZ, modulation format	57

List of Abbreviations

WDM	Wavelength Division Multiplexing
OTDM	Optical Time Division Multiplexing
LAN	Local Area Network
BER	Bit Error Rate
DSF	Dispersion Shifted Fibre
PMD	Polarization Mode Dispersion
NTT	Nippon Telegraph and Telephone Corporation
RSDPSK	Return Zero Phase Shift Keying
FEC	Forward Error Correction
MOD	Modulator
DPSK	Differential Phase Shift Keying
MUX	Multiplexer
SP	Same Polarization
AP	Alternate Polarization
DEMUX	Demultiplexer
OTN	Optical Transport Network
OXC	Optical Cross Connects
DWDM	Differential Wavelength Division Multiplexing
OADM	Optical Add/Drop Multiplexer
ETDM	Electrical Time Division Multiplexing
OSNR	Optical Signal to Noise Ratio
FWHM	Full Width at Half Maximum
MLLD	Mode Locked Laser Diode
MLFL	Mode Locked Fibre Laser
MLSL	Mode Locked Semiconductor Laser
EAM	Electro-Absorption Modulators
XPM	Cross Phase Modulation
FWM	Four Wave Mixing
NOLM	Non-Linear Optical Loop Mirror
SOA	Semiconductor Optical Amplifier
MZI	Mach Zehnder Interferometer

SOI	Silicon on Insulator
PLL	Phase Locked Loop
DCF	Dispersion Compensated Fibre
SLA/IDF	Super Large Area Fiber/Inverse Dispersion Fibre
EDFA	Erbium Doper Fiber Amplifier
SRS	Stimulated Raman Scattering
PRBS	Pseudo-Random Bit Sequence
FD-POP	Fourier Domain Programmable Optical Processor
TM	Transverse Mode
DS-OTDM	Dynamically Switchable Optical Time Division Multiplexing
MZ-OEO	Mach Zehnder Optical Electrical Optical Converter
UHD	Ultra High Definition
OPBF	Optical Band Pass Filter
AM	Amplitude Modulation
FPGA	Field Programmable Gate Array
ULAF	Universal line Access Family
ITU-T	International Telecommunication Union
ROAD	Reconfigurable Optical Add/Drop Multilplexer
ODLS	Optical Delay Line Structure
ATM	Asynchronous Transfer Mode
ASK	Amplitude Shift Keying
NRZ	Non Return Zero

List of Symbols

dB/km	Decibels per kilometer
μm	Micrometer
Mb/s	Mega Bits Per Second
THz	Tera Hertz
Gb/s	Gigabits Per Second
Tb/s	Terabits Per Second
km	Kilo-Meter
fs	Femto-Second
ps	Pico-Second
dB	Decibels
ϵ	Epsilon
D	Dispersion
λ	Wavelength
nm	Nano-Meter
TBd	Tera Baud
N	Number of Channels
B	Bandwidth
j	j^{th} channel
GBd	Giga-Baud
dBm	Decibels-Meter
L	Number of Bits in each Packet
K	Compression Rate
n	Number of Bits

List of Tables

- Table no.1.1 Table showing basic requirements for running optiSystem.
- Table no.3.1 Parameters for transmitters
- Table no.4.1 Parameters for various components of CSRZ and Duo binary modulation for format.

CHAPTER 1

Introduction

1.1. Motivation

Although humanity's quest of civilization dates back to antiquity, it was not until the latter half of the last century that developments were being made possible due to the advancements in the areas of electronics, optoelectronics and computer science. Moreover, the advent of the computers and subsequent innovations in consumer electronics have revolutionised the way people communicate thus steering human era in the world of information technology. Globalization and effective information sharing were the basic motive of this new era. With the moving time this has manifested itself in the exponential rise of internet data traffic and optical communication systems and networks. Indeed, the ever-increasing worldwide demand for ultra-high capacity communications have made contemporary optical networks an essential part of the social and economical infrastructure and that they will continue to act as one of the most important technologies of the future. Lately, the research revolving around optical communications has motivated a great deal of progress in other related fields such as opto-electronics, photonics, optical signal processing and material science in recent years. Thus it can be envisaged that photonic technology will play a key role in establishing the advanced IT infrastructure in the coming years.

1.2. Evolution of Optical Fibre Communication Systems

1.2.1. Early Works

There is no doubt that optical fibre communication systems are proliferating today, it started with the idea of transmitting optical signals inside silica glass which was quite impractical 40 years ago due to the extremely high losses inside silica (~1000 dB/km). In 1966 however, a researcher named K. C. Kao, et al. first demonstrated the possibility of practical telecommunications using silica fibres [1]. Later on Donald Keck came up with the production of low-loss optical fibre at Corning in 1970 along with the availability of

modulated light sources which gave boost to vigorous research and development work in the optical communication field and in 1978 finally started the first commercial deployment of practical fibre communication systems operating at $0.8 \mu\text{m}$ at a bit rate of 50 to 100 Mb/s. Later increase in researches and advanced technologies have led to the improvement of the fibre fabrication process which has led light wave systems to operate at $1.3\mu\text{m}$ and $1.5\mu\text{m}$ wavelength window, where the optical loss is further reduced to 0.2 to 0.3 dB/km. Figure 1.1 depicts the typical configuration of an early optical fibre communication system with electronic repeaters.



Figure 1.1: Optical fibre communication system using repeaters [2].

Fibre based optical communication started around 30 years ago with researches demonstrating the feasibility of high speed optical transmission through glass optical waveguide [2]. After decades of development of fibres, optical sources, amplifiers, advances in communication channels and receivers, optical communication systems are now a day's widely deployed. Today, propagation distances ranging from few of kilometres and spanning up to trans-oceanic distances is carried out by light on optical fibres with advances in wired telecommunication technologies. Increase in demand of transmission bandwidth has put a lot of stress on telecommunication network now-a-days. Apart from the growth of conventional telecommunication traffic like voice, cable T.V. etc, data traffic is on a high rise growing at up to 35% per year [3]. The internet traffic is exploding at a high rate of 100% per year which is contained in this growth rate, although total volume is not very high. The internet traffic will further accelerate this growth rate if this volume increases.

The spare capacity in many of the spared heavily loaded optical fibre links in United States is already exhausted [3], even though in 1550 nm available transmission bandwidth low loss window of optical fibre is around 25 THz [4]. The basic reason for this is that electronics in the present scenario lacks the necessary bandwidth needed to modulate the required amount of data onto the optical fibre. Furthermore the demand for increased bandwidth is expected to continue rising in the coming years. As per recent predictions by the scientists, it is estimated that the needed line capacity in parts of core network will be in hundreds of terahertz by the year 2015 [5]. Electronics do not have very high processing capabilities for processing of very high bandwidths even though traffic is carried by several fibres in the same cable. Maximum electronic speed available in recent times in laboratories is 40 Gb/s [6, 7] although a demultiplexer at 60 Gb/s has recently been demonstrated [8]; driver circuits operate at bit rate of 20 Gb/s [5]. Therefore some alternative to electronic load is necessary in order to transfer load onto the fibre. This electronic circuit bottleneck can be overcome by the use of some kind of optical multiplexing which can be carried in time as well as wavelength domain.

In wavelength division multiplexing (WDM) each of the low bit rate channel is modulated on to the specific wavelength of light. Wavelength division multiplexing makes straightforward use of the available bandwidth and performs multiplexing and demultiplexing using passive components. Over the years WDM has been a widely researched area particularly for point to point transmissions. In recent times optical networks based on wavelength division multiplexing have gathered much attention [9-14]. Transmission systems based on WDM have been commercially available of late now.

A complimentary technique to WDM is optical time division multiplexing. In OTDM each of the available channels is optically modulated on to a periodic train of very short optical pulses which are of same wavelength. By bit interleaving modulated pulse train, the channels are multiplexed and transmitted through the optical fibre. The aggregated signal after transmission is then optically demultiplexed in order to extract the channels that were low bit rate before electrical receiver which operates at the bit rate of tributary channels. Unlike WDM, OTDM requires active demultiplexing of the aggregated signal. For applications such as ultra high speed backbone links and local area networks (LAN's), telecom operators and research universities are investigating OTDM as a compliment to WDM. Two research

projects under ACTS programme, HIGHWAY and MIDAS, are as well investigating high speed OTDM. Ever-increasing demand for higher speeds and larger capacity because of rapid data growth on the Internet, has led to a steep increase in the usage of optical time division multiplexing in recent years basically due to its higher speed and ability to overcome the “electronic bottleneck” suffered by electronic components. In WDM multiplexing there is frequency domain multiplexing but in OTDM multiple data channels are transmitted in the form of interleaved, ultra-short duration optical pulses, into a single high-speed data stream particularly by controlling of their relative delay in the time domain. An optical gate at the receiving end is used to extract one base rate tributary from the aggregated signal for subsequent processing. OTDM (Optical Time-Division Multiplexing) is a very powerful multiplexing technique that is used in very high capacity of data transmission over optical fibre. If technique of multiplexing is not used then under-exploitation of the optical fibre’s bandwidth (Tb/s) becomes an important issue since the effective usage of maximum bandwidth of optical fibre is primarily dependent on the capability of the terminal and repeater equipments.

The electronic components that are commercially available are limited to around 10 Gb/s data rate, thus creating a bottleneck in obtaining higher speeds. Time domain multiplexing of a number of low bit rate optical channels is the basic principle behind this technology. OTDM system can be viewed as three big blocks: N transmitter block, line system, and receiver block. Laser sources, modulators, channel alignment systems, and multiplexer are parts of the transmitter blocks. Transmission fibres and optical amplifiers are contained in the line system. The receiver block contains timing/synchronization extraction circuit and channel demultiplexer. Channel allocation by time division multiplexing is dependent on the fundamental electrical data rate and the optical pulse width.

In order to multiplex more and more channels within the clock period with fixed electrical clock, the optical pulse width must be shortened. These shortened pulse width helps to reduce the crosstalk between channels since more of room is left in bit slot. But there is a problem with short optical pulses, they are subjected to heavy dispersion penalty as they travel long distances. Usage of transform-limited pulses and dispersion compensation techniques can help in the reduction of the dispersion effect on OTDM. Transform-limited pulses have the feature of minimizing the optical spectral pulse width of a given pulse. This

minimizes the pulse broadening caused due to dispersion. Addition of negative slope dispersion optical fibre can reduce the broadening of pulses over long distances. This basically depends on the choices of dispersion slope factor and also length of the dispersion compensated fibre, which in turn depends on the technology with which fibre is fabricated. As travelling distance increases over 100km, polarization mode dispersion also becomes a cause of concern.

Control on the accuracy of the channel alignment is also critical as transmission speed increases because more channels are multiplexed in fixed time period. Any channel misalignment can lead to crosstalk and dispersion which can adversely affect the performance of the OTDM system. For demultiplexing at the receiver end electro-optic switching technique or all-optical switching is used. The problem with electro-optic technique is that it is good only for transmission speed less than 40 Gb/s. Speed over 40 Gb/s is difficult to achieve due to restraints on electrical drive power. The principle behind all-optical switching is third order nonlinear effect of the optical fibre. Since the non linear response is in fs range it is highly suitable for ultra-fast speed transmission. Add/drop of individual channel or a number of channels is also allowed, which is great feature for network operation. The disadvantage of the all-optical switch is that it is very bulky and expensive to be made. Nevertheless, for successful demultiplexing accurate timing extraction is very essential. BER performance of the OTDM system can directly be affected by the timing jitter from the extraction circuit. Successful demonstrations of OTDM up to 400 Gb/s have brightened the future of commercial OTDM. The advantage of operating only on a single wavelength makes OTDM very successful. The possibility of running OTDM on existing WDM channels improves the overall data capacity. Being purely digital, it is easily adaptable with all digital networks. With the latest advancements in semiconductor technology and integration techniques, it will be possible to manufacture compact, stable and higher performance components for commercial OTDM system.

1.3. OTDM Transmission

The first successful demonstration of OTDM transmission was done in 1988 (4x4 Gb/s) at Bell Laboratory and since then there has been a tremendous change in the bit rate at which single wavelength channel OTDM systems are operating. OTDM products with bit rate 80

Gb/s have become commonly commercially available and 160 Gb/s and above systems are being actively pursued.

OTDM transmissions over 40 km dispersion-shifted fibre (DSF) has been achieved simply by employing an all-optical demultiplexer which is based on FWM in optical fibre using bit rate of 400 Gb/s [15]. For higher data rates even femtosecond pulse sources are used and the system in such cases is more sensitive to the degradations due timing jitter, chromatic dispersion, polarization mode dispersion (PMD) and fibre nonlinearities. Successful transmission of a 300 fs pulse at 640 Gb/s aggregate data rate was demonstrated by introducing a novel pulse shaping scheme, over a span of 100 km over a specifically designed fibre link with low residual dispersion and polarization mode dispersion [16]. NTT research laboratory has by far reported the highest system capacity achieved for single channel in which two 640 Gb/s OTDM data streams were polarization multiplexed so as to form a 1.28 Tb/s signal. The 1.28 Tb/s data is first polarization demultiplexed at the receiver end by a polarization beam splitter (PBS) into 640 Gb/s OTDM data and then extraction of a 10 Gb/s tributary from the 640 Gb/s data is done using dispersion flattened optical nonlinear loop mirror. The transmission over 70 km was successfully achieved using technologies including pulse compression, pre-chirp, higher order dispersion compensation, specialty fibre and ultrafast all-optical demultiplexing [17].

In spite of their increased data rate, ultrafast OTDM systems have always been limited by practical limitations like transmission over conventional fibre and utilization of economical components used for multiplexing and demultiplexing. 160 Gb/s line rate seems to be the best choice among the current sub-systems needed for high-speed systems. Using standard deployed fibre a field trial has been reported where an error-free transmission distance of 275 km has been achieved [18]. Combination of return-to-zero differential phase shift keying (RZDPSK) modulation format, forward error correction (FEC), polarization bit interleaving has lead to a maximum transmission distance potentially extending to 2000 km for a 160 Gb/s line rate [19]. Adaptive PMD compensation (including higher order PMD) and accurate dispersion slope compensation are major technical challenges that still need to be overcome.

Adopting of high-speed OTDM is not just for increasing the capacity of optic fibre communication system but it may also be combined with WDM technologies which give,

reduced complexity to the ultra-high capacity systems. In order to realize Terabit/s system with conventional WDM system 2.5 Gb/s or 10 Gb/s data are modulated on each of the wavelength with more than 100 channels. This increases the overall complexity of network. If we increase the data rate of each of the wavelength to about 100 Gb/s, in such cases, less than 10 channels are required. This reduces the system cost and also improves the practicality of such high capacity systems. Recently, there has been extensive research on WDM/OTDM transmission systems with a channel rate of 160 Gb/s (19 channels), 200 Gb/s (7 channels), and 320 Gb/s (10 channels) [20-22] which has increased the capacity up to 5 Tb/s by using hybrid scheme [23].

Figure 1.2 (upper part) depicts a 160 Gb/s OTDM transmission system as an example. The crucial component on the transmitter side is an optical-pulse source generator. The repetition rate of a produced pulse train depends on the base data rate (or on the symbol rate B) used. The system depicted in figure 1.2 has a base data rate of 40 Gb/s. The optical pulse train of 40 GHz is conjoined into four optical branches. The modulators (MOD) steered by 40 Gb/s non-return-to-zero (NRZ) electrical data signals produce 40 Gb/s optical return to zero (RZ) data signals.

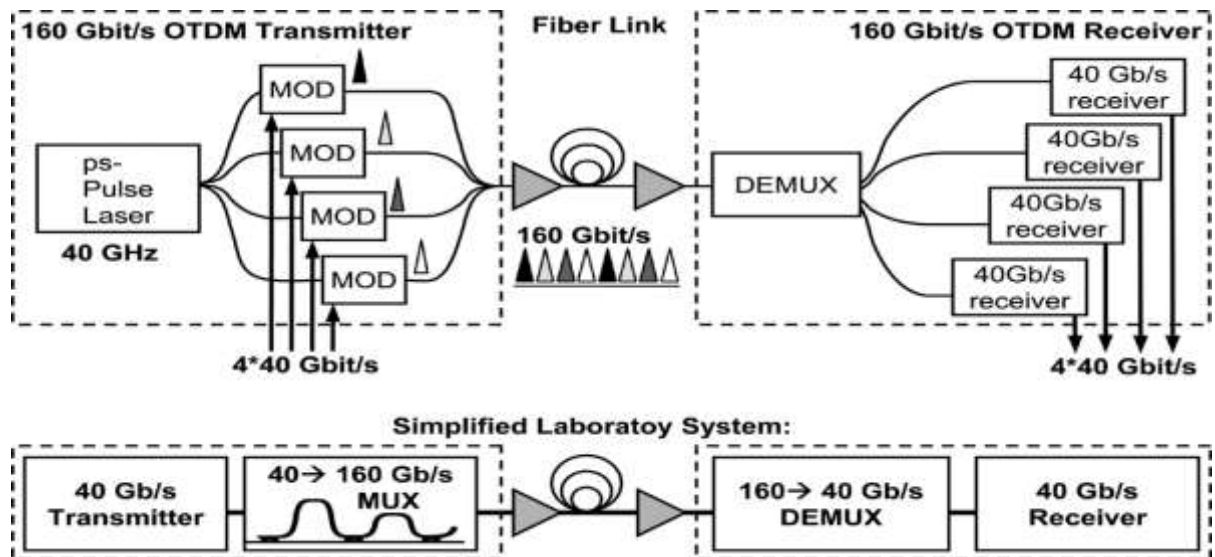

Figure 1.2: Demonstration of 160 Gb/s OTDM transmission system (upper part) and of a simplified laboratory system (lower part of the figure) [24].

The modulation formats that can be used are ON–OFF keying (OOK), differential phase shift keying (DPSK), differential quadrature phase shift keying (DQPSK), etc. The bit-interleaving of four optical data signals (TDM channels) generates a multiplexed 160 Gb/s optical data signal. Multiplexing (MUX) can be done such that all bits of the multiplexed data signal have the same polarization (SP multiplexing, SP signal), or adjacent bits have alternating (orthogonal) polarization (AP multiplexing, AP signal). The important component on the receiver side is an optical demultiplexer (DEMUX), which divides the four base rate data signals (TDM channels) for further detection and electrical signal processing.

The demultiplexer consists of two parts: an optical gate and a clock-recovery device. The optical gate acts as a rapid switch with a switching time smaller than the bit period (6.25 ps for 160 Gb/s) of the multiplexed data signal. The clock-recovery component feeds for the timing signal of the optical gate. Reimbursement for chromatic and polarization mode dispersion in transmission link is needed, in general, which relies on the type of single mode fibre used in the transmission system.

Apparatuses in research laboratories are often simplified as follows (figure 1.2: lower part): On the transmitter side one modulator is adopted and it is combined with the optical pulse source for a 40 Gb/s optical transmitter. The so produced optical data signal is then multiplexed by a fibre delay line multiplexer (MUX) to a 160 Gb/s data signal using either same polarization or orthogonal multiplexing schemes. Only one 40 Gb/s TDM channel is selected and detected at the receiver's side by one 40 Gb/s optoelectronic receiver at a particular point of time. In OTDM demonstration, all TDM channels are measured successively in this way.

1.4. OTDM Networking Prospects

Different optical transport networks (OTN) have been proposed in order to fully utilize the capacity of the transmission infrastructure [25]. The basic motive behind this intelligent and transparent optical network was that they provide various functionalities in a reliable, flexible, cost effective and scalable manner. Historically, WDM was the preferred technology to implement OTN due to its basic advantages like mature supporting

technologies, such as optical add-drop multiplexers (OADMs) and optical cross-connects (OXC).Dense wavelength division multiplexing (DWDM) based various network protocols and architectures, and wavelength routing have been studied [26-29]. However it has some serious practical limitations, such as rigid allocation of bandwidth and complex network management which has put limitations on its usage [30].

An advanced approach to this is employing of packet switching in the optical domain. In this approach information is transmitted across the network in the form of very high speed data packets. These packets have destination address encoded into them and are routed according to that particular encoded address. OTDM has a powerful digital and synchronous behaviour which has proven to be an excellent solution for network implementations. OTDM is deemed as one of the most promising choice for next generation all-optical networks because of its efficient and economical way of handling the massive amounts of information that will be required in carrying over communication networks in the coming future. Many network architectures based on this ‘optical packet-switching’ have been implemented for Local Area Network (LAN) [31] .The major challenge here includes ultrafast optical switching signal processing and optical buffering [32].

Apart from being implemented in packet-switched architectures, OTDM has very wide scope and also research progresses in OTDM core network along with ultrafast add/drop multiplexing components has been dramatic. First OTDM network experiment was done in 1994 [33], since then a large number of practical optical networks based on high speed OTDM architectures have been developed which are capable of handling ultra high-speed communication needs [34-36], also recently a 160 Gb/s OTDM network field trial has been reported [37].

The ever rising demand for the rapid growth of bandwidth-intensive data applications (i.e., desktop video conferencing, distance learning, telemedicine and video-on-demand) it is expected that OTNs with several 10s (or even 100s) of Tb/s aggregated point to point capacity will be stationed in the near future. High capacity leased line service (i.e., entire wavelength or optical channels) are also emerging OTDM based service for service providers. A high capacity as well as high speed network solution is very desirable when faced with this situation. More efforts are being made on combining OTDM technologies with WDM to enhance network performance in terms of transmitted bandwidth as well as

granularity [38-41]. It would require extensive researches for the best architecture for future all optical networks for being fully conceived, it can be also expected that with further research and developments of optical processing components, OTDM will be one to find a wide range of applications in the coming future ultra high capacity all optical networks.

Optical networks use a union of both of wavelength division multiplexing (WDM) and time division multiplexing (TDM) for the optimization of the transmission capacity. Realization of TDM can be done in two ways: electrical multiplexing (ETDM) and by optical multiplexing (OTDM) of a high-speed data signal. In current scenario, 40 Gb/s systems based on ETDM have been implemented and the first 100 Gb/s ETDM experiments have been performed in the laboratory. Using the same data rates, OTDM transmission experiments were carried out about ten years earlier. For instance, the first 100 Gb/s OTDM-transmission demonstration over a length of 36 km fibre link was reported in 1993 [42]. OTDM transmission technologies had a lot of developments with much higher bit rates and much longer transmission links, as has been demonstrated in many of the review articles [43-44]. OTDM transmission technology is often considered a technique to study high speed data transmission in fibre and which will be replaced by ETDM as soon as electrical signal processing is made available at the required data rate. Considering this point of view, one of the major tasks with OTDM technology is investigation of the feasibility of ultrahigh speed data transmission. This involves extensive study about the advantages of high TDM bit rates that are eventually degraded by an increase in ruinous effects. But a high TDM bit rate makes transmission systems more susceptible to chromatic dispersion (CD) and polarization mode dispersion (PMD) and they also require a higher optical signal to noise ratio (OSNR) in the wavelength channel. For a high OSNR a higher signal power is the basic requirement which will make the system more sensitive to fibre nonlinearity.

A more challenging and distinguished feature of OTDM technology is that optical networks will emerge into “photonic networks,” which will allow ultrafast optical signals of any bit rate and modulation format to be transmitted and processed from one end to other end without the requirement of any optical–electrical–optical conversion. Targeting this, OTDM technology presents us with the challenging task of investigating and developing high-speed optical signal processing as well as exploring the ultimate capacity for fibre transmission

using a single wavelength channel. The “photonic network” appears to be an application based task for the distant future technologies.

1.5. OTDM Transmitter

The pulse source is the most important component in an OTDM transmitter. The basic characteristics of an optimum pulse source is that it must be capable of providing the following: a properly controlled repetition frequency and wavelength, transform limited pulses, pulse width shorter than the bit period of the multiplexed data signal, a timing jitter less than the pulse width, low amplitude noise, and a high extinction ratio. Typical values for stable operation of 160 Gb/s transmission are jitters less than 300 fs, pulse width [full-width at half-maximum (FWHM)] less than 2 ps for same polarization multiplexing and less than 4 ps for alternating multiplexing, extinction ratio greater than 27 dB and amplitude noise less than 3%. Also, if some sort of phase-modulation format like as differential phase shift keying or differential quadrature phase shift keying is used, further pulse source requirement increases, namely, the pulse source must be highly stable in terms of carrier phase as well as wavelength.

Optical pulse sources required for high bit rate transmission implementations include mode locked laser diodes (MLLDs) which can be either external cavity devices (e.g., [45], [46]) or monolithically integrated devices (e.g., [47], [48]), mode-locked fibre lasers (MLFLs) (e.g. [49], [50]), mode-locked solid-state lasers (MLSLs) [51], and externally modulated continuous wave lasers [pulse carving, e.g., by an electro-absorption modulator (EAM)] (e.g., [52]). These optical pulse sources provide a 10 GHz or 40 GHz pulse train with a width of pulse of about few picoseconds. Until unless the pulse width is sufficiently narrow enough for the considered bit rate, further pulse compression and optical regeneration (e.g., [53-56]) is used. Pulses with large power can produce a super continuum spectrum. Multiple wavelength pulse can be produced from spectral slicing method, which is of great importance for WDM/OTDM applications.

Figure 1.3 shows the optical spectrum also known as mode comb spectrum of a 40 GHz periodic pulse train produced by a monolithically integrated mode locked laser device. A miniature line width and a big contrast ratio of the mode combs show a periodic train of pulses with low phase and low amplitude noise. If using phase modulation formats such as

differential phase shift keying or differential quadrature phase shift keying then this spectrum must have long term stability in the position of the wavelength for proper phase demodulation in the receiver side.

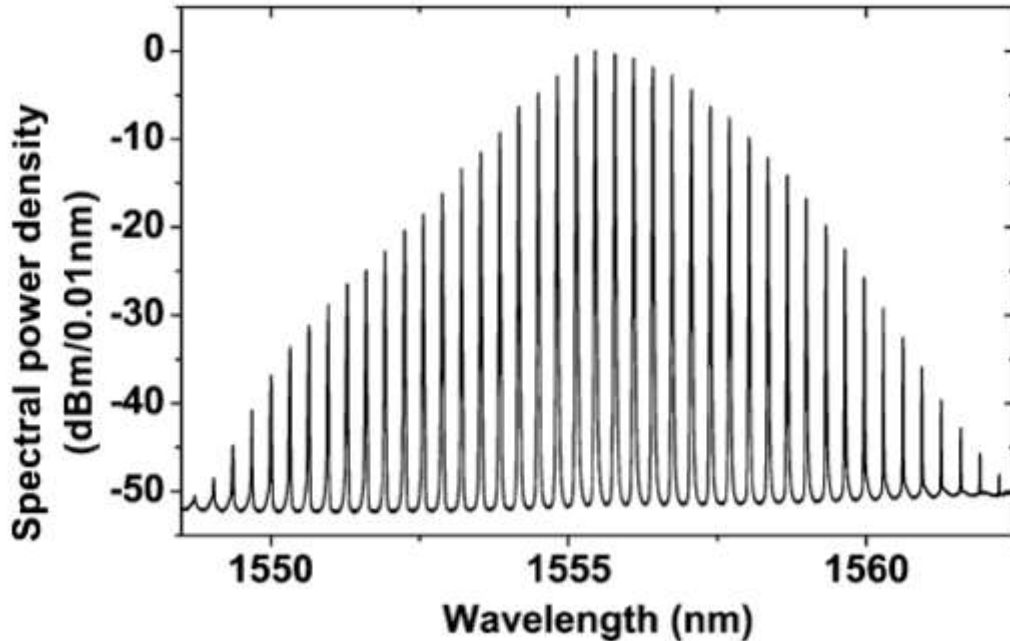

Figure 1.3: Mode locked laser's pulse spectrum successfully demonstrated in 160 Gb/s DPSK experiment [24].

This is major disadvantage of mode locked fibre laser. Mode locked fibre laser requires harmonic mode locking and long term wavelength stability is also a critical issue. In OTDM experiments, modulators most generally used are Lithium-Niobate (LiNbO_3) for modulation of the generated optical pulse train. However only in few OTDM experiments, EAMs are also used. The modulation features of LiNbO_3 modulators are very broadband extending up to 80 GHz and slightly dependent on wavelength in the 1.3 to 1.5 μm range. Also, a nearly perfect π phase shift is obtained in DPSK and DQPSK systems by use of a push-pull feature of LiNbO_3 Mach Zehnder modulator, which is biased at zero transmission and run by two times the " π " switching voltage [57-58]. Modulators of this type may show some residual amplitude modulations as well. Those, however, are less harmful as compared to the deviations from the desired phase shift [59].

In a DPSK systems, modulation of each pulse takes place in the phase with $n \times \pi$, $n \in \{0, 1\}$, whereas in a DQPSK system, each pulse modulation is in the phase with $n \times \pi/2$, $n \in \{0, 1, 2, 3\}$. As a result, in a DQPSK modulated signals, each optical pulse or symbol carries one out of four logical states instead of one out of two states as in an on-off keying or a differential phase shift keying system. For these two however, the data rate is equal to the symbol rate, whereas if we consider differential quadrature phase shift keying, the data rate is twice the symbol rate.

Most optical MUXs are of the kind as schematically depicted in the lower part of figure 1.2. Delay line MUXs produces a high bit rate test signal for laboratory researches by uniting several copies of one data signal with distinct relative delays. They are accomplished by using 2×2 optical couplers and optical delay lines either as fibre devices or as planar light wave circuits. One of the most important criterions for these “test multiplexers” is that there is no interrelation between the adjacent bits of the multiplexed data signal. We can get this simply by using a delay time long compared with the bit period of the input signal.

In real time however, OTDM MUXs employs different modulators to provide a multiplexed data signal. A case of a “real” MUX is demonstrated in [60] and [61]. Simply by using an integrated planar light wave circuit, such real MUX, permits the multiplexing of eight different 20 Gb/s data signals to one multiplexed 160 Gb/s data signal. Also “real” MUX is reported in [62]. It provides separate modulation of all TDM channels along with optical-phase alignment between adjacent bits.

Typically the delay line MUX provides an arbitrary relative phase to the adjacent pulses in the multiplexed data signal since no attempt to stabilize the delay-line MUX for a proper relative phase of the adjacent pulses is made while performing these experiments. The tolerance of the transmission system with respect to chromatic dispersion and fibre nonlinearity effect for a well defined relative phase of adjacent data pulses in the multiplexed data signal is expected to increase, thereby increasing the spectral efficiency [63]. Hence, proper control of the optical phase alignment between adjacent bits of the multiplexed data signal is a criterion of an amplitude modulated system. Many methods for demonstrating optical phase alignment has been studied and many OTDM and OTDM/WDM transmission researches have been realized using formats like carrier-suppressed RZ in which the adjacent bit optical pulses in slots have a relative phase shift of π . Also the up gradation for the

transmission system is not as important criterion so as to justify the effort of adjustment and stabilization of a “test-multiplexer,” not for phase-modulated data signals as well. The well-defined phase of adjacent pulses in differential phase shift keying and differential quadrature phase shift keying transmission systems is required behind the DEMUX (i.e., within the TDM channel) only. The relative phase of adjacent pulses inside a TDM channel does not depends on the adjustment of the delay line MUX.

1.6. OTDM Receiver

Different optical gates are used for demultiplexing. With data rates extending above 160 Gb/s, most of the optical gates are fibre based using cross phase modulation (XPM) or four wave mixing (FWM) in fibres [43-44]. One of the best examples is the nonlinear optical loop mirror (NOLM), which was used as a DEMUX for data rates extending up to 640 Gb/s, and it is the fastest DEMUX reported so far. One of the classes of optical gates based on cross phase modulation and frequency wave mixing is a semiconductor optical amplifier (SOA). XPM based optical gates examples include the SOA in a Mach-Zehnder interferometer (SOA-MZI), the semiconductor optical amplifier in a polarization discriminating switch (SOA-UNI) and the semiconductor optical amplifier in a Sagnac interferometer.

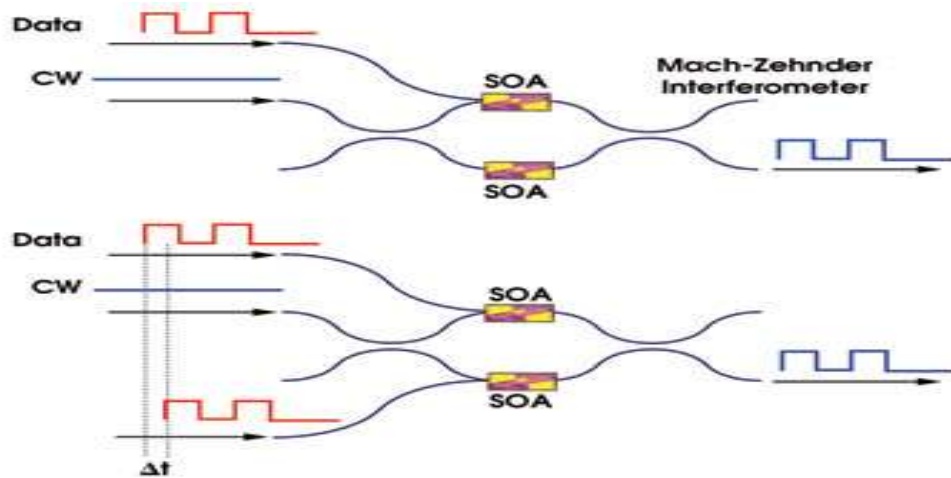

Figure1.4: Schematic of Mach -Zehnder interferometer with a semiconductor optical amplifier in both of the two arms of interferometer [59].

Phenomenon of all optical switching is used in semiconductor optical amplifiers and fibre-based optical gates. An optical signal is used to control the gate, which switches an optical data signals. Therefore these optical gates need an appropriate optical pulse source. Electro absorption modulator is one of the many optical gates used in high speed transmission experiments. In electro absorption modulators, an electrical control signal controls the gate, switching the optical data signal. This simplifies DEMUX to a great extent. Many transmission experiments employ this switch as DEMUX. Recently, EAM monolithically integrated with a photodiode, and an electrical signal from the photodiode steered the electro absorption modulator directly. Demultiplexing up to a data rate of 500 Gb/s has been reported. However, this gate requires an optical control signal.

The DEMUXs mentioned above have the capability of selecting only single TDM channel of the multiplexed data signal (i.e., single channel output operation). Serial-parallel configuration of such switches helps in achieving multiple channel output operation. Applying data rates of 160 Gb/s and above, already scaled optoelectronic clock recovery was successfully achieved using phase-locked-loop (PLL) configurations. This was done using optical phase comparators which was based on frequency wave mixing or cross phase modulation in a semiconductor optical amplifier or opto-electrical phase comparators based on electro absorption modulators.

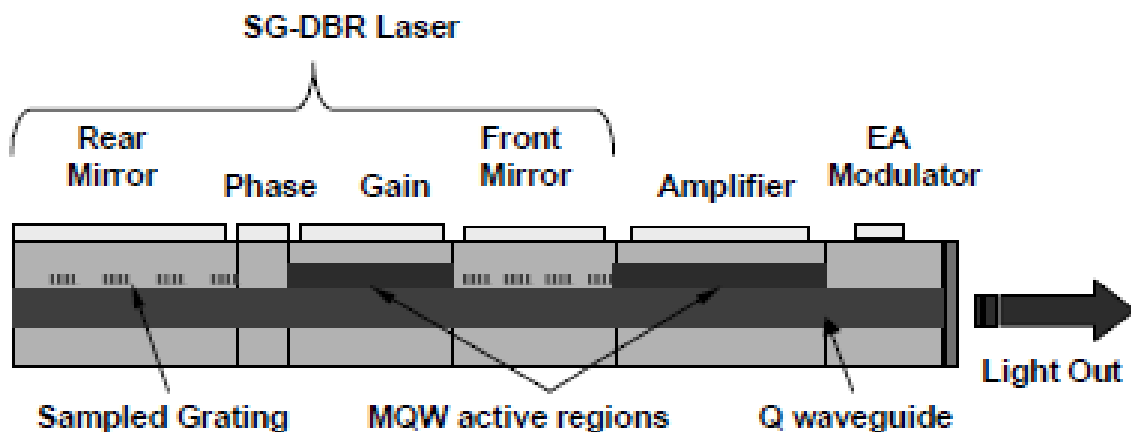

Figure 1.5: Schematic SGDBR-SOA-EAM [60].

SOA based as well as EAM based clock recovery components have been implemented at up to 400 Gb/s and 320 Gb/s respectively. Due to unavailability of a proper clock-recovery device many experiments related to transmission were also performed without restoring the clock signal from the multiplexed data signal. Two different methods were used. A clock signal produced at the transmitter was transmitted together along with the data signal at a different wavelength over the length of fibre. Or at the transmitter end multiplexer was adjusted for slightly distinct pulse amplitudes in such a way that simple photo detector detects the clock signal at the receiver end.

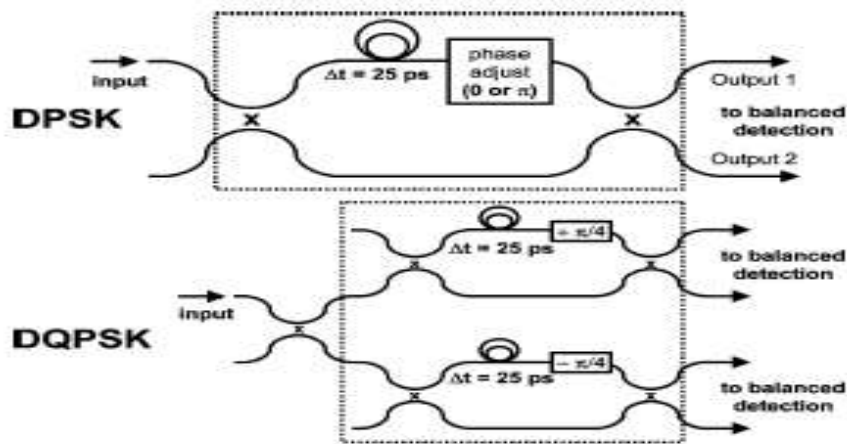

Figure 1.6: 40 Gbaud base rate demodulators for DPSK and DQPSK transmissions [24].

In experiments relating to OTDM transmissions, the DEMUX output is commonly connected with the optoelectronic receiver using an optical amplifier along with an optical filter. In DPSK and DQPSK transmission demonstrations, an additional demodulator is placed between DEMUX and optoelectronic receiver. The phase modulated data signal is converted into two corresponding amplitude modulated data signals using the demodulator. In the DPSK implementations however, Mach Zehnder interferometer is used as the demodulator as depicted in figure 1.6. The delay between both interferometer arms is chosen to be of one bit period taking at the base rate, for example for a base rate of 40 Gb/s, 25 ps is taken. In case of DPSK, zero phase difference adjacent bits, carrying the logical information corresponding to a “space” in on-off keying, interfere at one of the ports of the

interferometer (e.g. port1) constructively and destructively at the other port (e.g. port 2). Whereas adjacent bits having a phase difference of π , carrying the logical information corresponding to a “mark” in on-off keying, interfere constructively at port 2 while interfering destructively at port 1. Detection using a balanced photo detector of the two complementary signals shows an improvement of 3 dB, as compared with the on-off keying. The demodulator used for differential phase shift keying signal is also depicted in figure 1.6. It consists of two Mach–Zehnder interferometers, both having a differential delay at the symbol base rate (in the interferometer arms) of one bit period in addition to phase shift of $+\pi/4$ or $-\pi/4$ for the detection of in phase or quadrature component respectively. The active matching of DPSK and DQPSK demodulator to the transmitter wavelength is essential for proper operation. This also needs pulse source in the transmitter, which gives a high stability in terms of the carrier wavelength.

1.7. Transmission Line

Fibre's of link length of the order of 1000 km is sought after for applications in commercially used systems. However, these fibre lengths requires compensation of chromatic and polarization mode dispersion for ultra high speed data to be transmitted. It is essential to compensate both the path averaged chromatic dispersion ($D = 0$) at the mid wavelength of the pulse and the path averaged chromatic dispersion slope ($dD/d\lambda = 0$) for a 160 Gb/s system. This is essential because the slope of the dispersion generates oscillations near the trailing edge of the data pulse signal, no matter even if $D(\lambda) = 0$ for the mid wavelength λ of the data signal pulse. Presently, the most reliable dispersion compensation techniques are based on the usage of dispersion compensating fibre (DCF), which compensates at the same time for both dispersion and dispersion slope with respect to wavelength. Usually, the dispersion compensating fibre is concentrated as module in the repeaters and hence does not contribute to the fibre's transmission length. Alternatively dispersion compensating fibre has additionally emerged into inline dispersion-managed-fibre (DMF) transmission lines. The dispersion managed fibres are a pair of transmission line fibres, which together pay off for the path-averaged D and $dD/d\lambda$ over a wider range of wavelength.

Combination of different types of transmission fibres with their associated dispersion compensated fibres have been researched for high-speed data transmission at 1550 nm wavelength. These fibre include a standard single mode fibre (dispersion $D \approx 17$ ps/nm/km), dispersion shifted fibres ($D \approx 0.1$ ps/nm/km), and different types of nonzero dispersion shifted fibres ($D \approx 4-8$ ps/nm/km). Furthermore, there are several types of dispersion managed fibres such as single mode fibre or reverse dispersion fibres and super large area fibre or inverse dispersion fibre. The “Super Large Area” fibre have value of dispersion $D \approx 20$ ps/nm/km and for “Inverse Dispersion Fibre” dispersion ranges around $D \approx 40$ ps/nm/km, which jointly compensate for D and $dD/d\lambda$.

The tolerances with respect to residual dispersion or even residual single mode fibre or dispersion compensating fibre length are critical for high speed systems. For example, data rate of 160 Gb/s and pulse width of 1.3 ps implementation yield a tolerance (eye-opening penalty of 1 dB) of about ± 2.5 ps/nm relative to a single mode fibre length of ± 150 m. Also in such experiments a fine tuning of ± 50 m is suitable. An additional automatic dispersion compensation along with dispersion compensating fibre is required to control tolerances over a wide range of environmental temperature range. Different tuneable dispersion compensators have been proposed.

With data rates exceeding 640 Gb/s and beyond, dispersion compensation becomes insufficient for many of the fibres. In such cases higher order dispersion terms ($d^2D/d\lambda^2$) have to be considered. Concurrent compensation of the dispersion slope ($dD/d\lambda$) and of $d^2D/d\lambda^2$ is obtained by using excess dispersion (D) along with a phase modulation of the pulse. Compensation of dispersion using this technique was successfully realized in a transmission experiment over a 70 km dispersion managed fibre link comprising single mode fibre with reverse dispersion fibre. Alternatively, modern fibres like the super large area fibre or inverse dispersion fibre are widely suited for high speed data transmission. A 2.56 Tb/s differential phase shifted keying data signal having a symbol rate of 1.28 TBd, was transmitted over 160 km super large area fibre without application of any other refined compensation scheme.

Polarization mode dispersion also imposes severe limitations to the high bit rate data transmissions. The cause behind polarization mode dispersion is slight birefringence of the

fibre and other components in the fibres transmission link. For example, value of polarization mode dispersion (PMD) smaller than $0.05 \text{ ps}/\sqrt{\text{km}}$ is required to implement a low-penalty 160 Gb/s transmission system over a 160 km length fibre link. Modern fibre's such as the super large area fibre /inverse dispersion fibres (SLA/IDF) fibre has a PMD value much less than $0.05 \text{ ps}/\sqrt{\text{km}}$. On the other hand, earlier installed fibres used to have larger PMD value. In contrast to chromatic dispersion, compensation of polarization mode dispersion is much more difficult because it changes with time and wavelength in a random way. Hence, automatic plus adaptive PMD compensation is needed. Adaptive polarization mode dispersion compensation has been realized for data rates up to 160 Gb/s. In many experiments relating to ultrahigh bit rate transmission, first order polarization mode dispersion was compensated by manually regulating the polarization of the data signal at input of the transmission link.

One of the major causes for signal degradation is fibres nonlinearity. Experiments relating to high speed transmission are usually performed in the quasi-linear (pseudo linear) transmission regime in which the nonlinear length exceeds the fibres dispersion length. If both the path averaged dispersion as well as dispersion slope is close to zero then a high local dispersion becomes advantageous for this kind of transmission regime. The data signal pulses which are short, disperse very rapidly in the fibre, dispersing into many adjacent time slots before the restoration of the original pulse sequence by dispersion compensation. Hence, the pulse peak power is low for most of the path along the length of the fibre. Subsequently, fibres with high dispersion D are good for high speed transmissions. For instance, with 160 Gb/s data transmission, remarkable results with transmission distances extending up to 2000 km have been obtained using non zero dispersion shifted fibre [71]. On the other hand, 160 Gb/s data transmission over the super large area fibre with large local dispersion and low nonlinearity (large effective area) made possible to achieve a transmission distances exceeding 4000 km.

OTDM data conduction beyond 160 Gb/s was for the first time realized in the NTT laboratories. Illustrations of this work are the mentioned single wavelength channel, single polarization (SP) transmission experiments: 200 Gb/s over length up to 100 km dispersion shifted fibre, 400 Gb/s over 40 km length of dispersion shifted fibre, 640 Gb/s over 60 and 92 km length single mode fibres and the OTDM/WDM experiment: 1.4 Tb/s over 50 km

length dispersion shifted fibre. In these experiments however on-off keying modulation format was used, and the also terminal equipment mainly consisted of fibre devices. The transmitter pulse source used was either a mode locked fibre laser followed by an optical-pulse compressor or a pulse source based on super continuum generation (SC-pulse source). OTDM receiver consisted of a DEMUX which was an optical gate based either on a non linear optical loop mirror or on frequency wave mixing in fibre. An exclusion to this was the optical clock-recovery device, which consisted a phase locked loop with a phase comparator based on frequency wave mixing in a semiconductor optical amplifier. For inline amplifiers EDFAs were used.

1.8. Principle of OTDM

With the ever increasing demand for higher speed and larger capacity brought about by the rapid data growth on internet, optical time division multiplexing has attracted lots of potential applications in recent years primarily because of its two basic advantages: ultra high speed and its ability to overcome the “electronic bottleneck” of electronic components. WDM multiplexing occurs in the frequency domain whereas in OTDM multiple data channels are transmitted in the form of ultra-short duration optical pulses interleaved into a single high-speed data stream by controlling of their relative delays in time domain. An optical gate is used at the receiving end in order to extract one base rate tributary from the aggregated data stream for further processing. The operating principle of OTDM is as shown in figure 1.7.

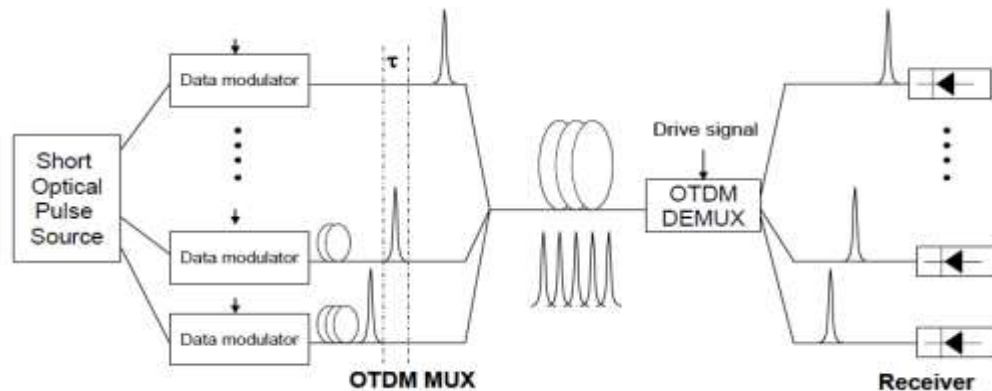

Figure 1.7: Schematic of an OTDM system [34].

In spite of the fact that such systems have great potential to operate at speed much higher (>100 Gb/s) than the speed that is limited by electronic components, several technologies are required in order to implement high speed OTDM systems. Technologies capable of providing ultra short pulse source with high repetition rate, high speed demultiplexing and clock recovery and accurate dispersion compensation are some of the mentioned ones. Extensive research is going on in many of these technologies and is still at the research stage, which makes high speed OTDM currently a relatively expensive transmission solution with wide scope of applications.

Despite of all these OTDM's capabilities cannot be neglected and it is still a very promising technology for upcoming future applications to increase the transmission capacity of a fibre system. If we compare to conventional WDM transmission systems, OTDM offers several advantages.

- ❖ Because of usage of only one wavelength in a pure OTDM system, the gain tilt problem and dispersion tilt problem is solved in OTDM transmission system which is prominent in wide band WDM transmission. Also, nonlinear effects which are major disadvantages for WDM systems such as four waves mixing (FWM) and stimulated Raman scattering (SRS) can be avoided.
- ❖ OTDM can also be used in conjunction with WDM. OTDM can be used to increase the data rate of WDM channels which reduces the overall complexity of the point-to-point systems. This also has the capability for enhancing the spectral efficiency for WDM system.
- ❖ Through careful manipulating of data in the electrical domain, an organized OTDM transmission system may be made to provide a truly high speed and low latency data link with utmost parallelism. This finds many applications in both the computing industry and scientific data acquisitions.

1.9. Generation and Detection of OTDM Data

The limitations of electronic data generators and electro-optical converters are typically about 100 Gbaud. Although optical components permit such high baud rates but there is no

direct method which encodes such ultra dense optical channel from electronic data. However, optical time division multiplexing makes it possible to attain higher baud rates by combining up of several low bandwidth data streams into a single data stream. This research was spearheaded by M. Nakazawa in the 1990's with the revolutionary demonstration of a 640 Gbaud link. Symbol rates above 1 Tbaud were demonstrated .The information is conserved and depends upon successive inserting of a symbol from each source with a small amount of temporal delay with respect to the previous symbol. To avoid overlap between neighbouring symbols, the time slots containing them must be extremely short. To combine N channels of bandwidth B into one, the aggregated bandwidth required is $N.B$ and the symbol period is $\frac{1}{N.B}$. As a result, the incoming signals must be encoded in return-to-zero (RZ) format on light pulses shorter than the symbol period. Figure 1.8 depicts the time-interleaving process. Each of the channel j is delayed by an integer number of symbol periods given by $\frac{j-1}{N.B}$ before being added to the OTDM stream. The pulse width of the tributaries must be compressed in order to match according to the baud rate and optical source so as to meet the criterion:

$$T_{FWHM} < \frac{1}{2(N.B)} \quad (1)$$

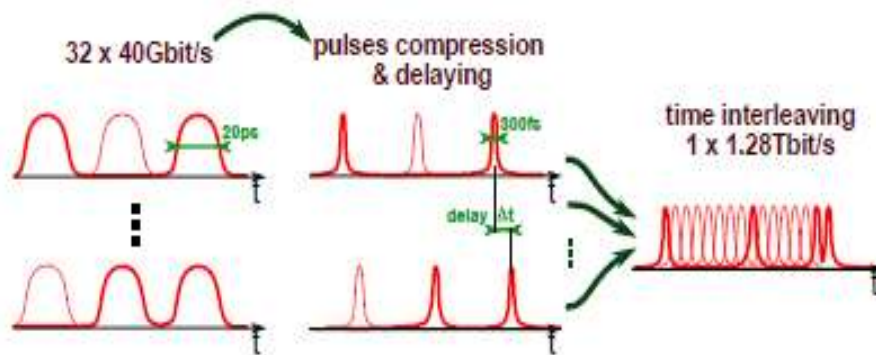

Figure 1.8: Time interleaving concept behind low baud rate channels. The signals are compressed and then delayed respective to each other and finally combined into single serial channel. Time scale not realistic for better understanding [38].

1.10. Interleaving Stages

Experimental implementation of an OTDM requires N data generators that are too costly and complex to run. Test beds usually use a single low bit rate data sequence which is encoded with a long enough random pattern (PRBS 231-1). In order to decorrelate signals, the original signal is first split into N copies and then each is delayed by a large number of bits to allow decorrelation among them. Interferometric device is required for splitting, delaying and recombination operations. Figure 1.9 depicts the setup used in OTDM experiment to generate signals at a bit rate of 640 Gb/s or 1.28 Tb/s. A 40 GHz train of pulses is produced by a mode locked optical clock which is synchronized with an electronic clock signal. The pulse width is chosen to be 1.4 ps which is too broad and hence do not allow terabaud time multiplexing without overlap among the channels. Two successive compression stages using a highly nonlinear fibres (HNLf) and band-pass filtering (BPF) are used which reduces the length of the pulses to about 275 fs (or 500 fs for the 640 Gb/s case), which are then encoded with a $(2^{31} - 1)$ pseudo random bit sequence (PRBS) generator using a Mach-Zehnder modulator (M-Z).

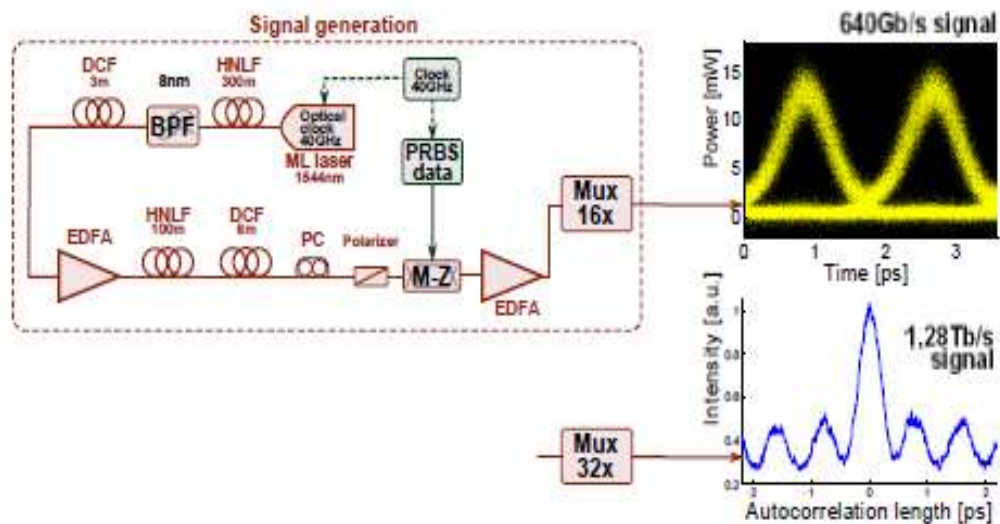

Figure 1.9: Generation of a 640 Gb/s PRBS signal [28].

A mode locked fibre laser produces a train of pulses which is then encoded using Mach-Zehnder modulator. The compression stages ensure that the pulses are short enough so that

there is no overlapping after the interleaving operation. The optical sampling scope observes the output signal (640 Gb/s) along with a second harmonic generation autocorrelator (1.28 Tb/s). The 40 Gb/s sequence is then multiplexed to 640 Gb/s or 1.28 Tb/s with interferometric multiplexing stages (MUX) replicating 16 or 32 times the sequence from a single PRBS pattern generator.

1.11. Bandwidth Requirements

The relationship of the time-bandwidth product originating from the properties of the Fourier transform depicts a link between the pulse width and the extent of the optical signal spectrum [65]. Pulses having the smallest product $\Delta\nu \cdot \Delta\tau$ are said to be transform limited or bandwidth limited.

$$\Delta\nu \cdot \Delta\tau \geq 0.44 \text{ (Gaussian pulse)} \quad (1)$$

$$\Delta\nu \cdot \Delta\tau \geq 0.315 \text{ (sech}^2 \text{ pulse)} \quad (2)$$

The channels have a very wide spectrum if we talk about ultra dense OTDM data. But this forces a strong limitation to the maximum baud rate in an OTDM transmission. In fact many of the telecommunication systems depend upon Erbium-doped fibre amplifiers (EDFA) that have a limited gain band. Generally all optical signal processing operations, involving effects like FWM or XPM, between multiple signals may require an extended spectral band, for example both the C and L bands. This is in particular the case for the OTDM demultiplexer as well as optical RF spectrum analyzer. However, operation in the L band makes the implementation of the experiments difficult, in particular due to the reduced performance of EDFAs in the L band.

1.12. OTDM Demultiplexing

Direct detection of OTDM data is not possible because optoelectronic converters do not have the required bandwidth. Instead a single tributary channel is extracted from the main stream whose received rate is equal to the baud rate accessible to photo detectors. Demonstrations using three techniques have been proposed in literature, using FWM based

nonlinear sampling gates, coherent detection with a pulsed local oscillator or time lens to frequency mapping [66]. High baud rate signals are demultiplexed using a second short pulse train (pump) at the repetition rate of the tributary. AND gate is used to extract one OTDM sub-channel from the pump and OTDM data signals passing at a high photonic speed. Selection of the desired channel depends on the synchronization and adjustment of the relative delay between pump and signal. The AND gate operation is performed by degenerate FWM of the two channels at different wavelengths. Other schemes also exist, for example based on nonlinear optical loop mirror (NOLM).

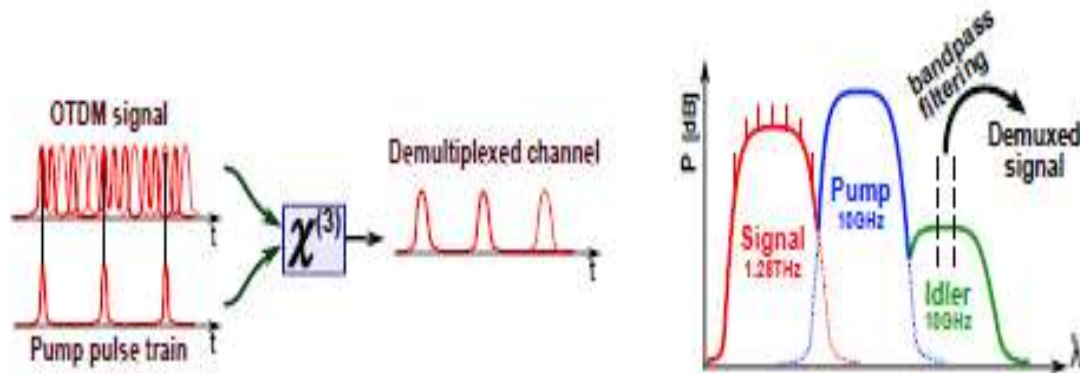

Figure 1.10: OTDM demultiplexing by nonlinear sampling. Extracting a single tributary channel by nonlinear mixing of the OTDM signal with a pulsed pump signal at lower repetition rate [10].

1.12.1. Nonlinear Demultiplexing Setup

The pulse train at repetition rate similar to that of the tributaries is produced locally at the receiver with a mode locked laser source. The synchronization of the pulse train with the OTDM data stream is maintained using a clock recovery from the OTDM channel. Synchronization using clock recovery at baud rates of 160 Gbaud and 640 Gbaud have been experimented using methods based on an electro absorption modulator or nonlinear sampling with a phase locked feedback loop. However, back-to-back demultiplexing can also be performed without clock recovery, using the same clock source for both the data and pump mode locked lasers. This sufficed as a test bed especially for high bandwidth OTDM devices, provided that no long distance transmission was attempted.

Data and pump channels can be respectively centred at 1550 nm (C-band) and 1572 nm (L-band). Synchronization in time is maintained between OTDM signal and the pump pulse train so as to coincide with the targeted tributary. Dispersion can be managed using the sampling operation in a dispersion engineered chalcogenide chip waveguide with sufficient bandwidth for propagating the OTDM signal and the pump without significant dispersion induced walk-off. Wide bandwidth [33] and anomalous dispersion characteristics allows phase matching because of which degenerate FWM generates an idler signal centred at 1605 nm. For very high rates of the order of 1 Tbaud, the total bandwidth required exceeds 40 nm which only fewer nonlinear media can offer. Further band pass filtering and amplification of the idler channel produces the demultiplexed channel at 10 Gb/s. Multiple successive band pass filters can be used to remove the unwanted pump signal and ASE components from the optical field as depicted in figure 1.11. Although there comes a difficulty in compression of the pump pulse train in the L-band since it requires testing of multiple configurations. This was basically because of the need to push the C-band mode locked laser producing the initial pulse train to the longest wavelength accessible in its range, followed by wavelength conversion to the L-band.

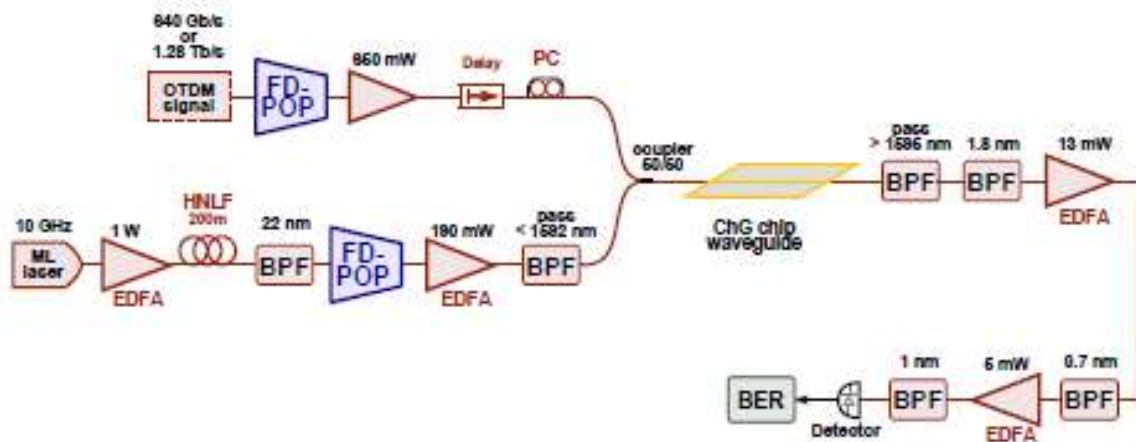

Figure 1.11: Demultiplexing of 640 Gbaud or 1.28 Tbaud down to 10 Gbaud tributary channels [28].

This gives pulse widths of 305 fs to 470 fs according to the schemes used. The demultiplexing BER used 470 fs pulses that give the best temporal shape and timing jitter.

Modification in the raw pump and signal channels using two FD-POP in order leads to improvement in quality. Dispersion compensation of 2nd, 3rd and 4th orders as well as spectral shaping gives quasi transform limited Gaussian pulses. This also offers flexible control over the centre wavelength and bandwidth of the signals.

In order to avoid degradation and destruction of the sample total power coupled to the input facet of the waveguide is limited to 23 dBm. Insertion loss could be aggregated to about 13.5 dB which includes coupling losses by lensed fibres (2×4.5 dB) and propagation losses along the selected TM mode of the waveguide (4.5 dB). These losses, in addition to the limited efficiency of the FWM process, results in an output idler signal whose power level is around -45 dBm for a total pump with signal power of 23 dBm.

One of the severe issues here comes is to overcome the re-amplification of the idler signal from a signal of ultra low power level. L-band amplification at 1605 nm is extremely difficult here given the reduced efficiency of Erbium doped fibre amplifiers in this particular region of the spectrum. Therefore a low noise EDFA can be used just above its noise threshold followed with a second booster amplifier and band pass filters.

The demonstration of this approach has been successfully done with a chalcogenide chip sample having baud rate of 1.28 Tbaud [33]. This scheme if repeated for reduced bandwidth for both data signal and pump resulted in error free demultiplexing at 640 Gb/s. Bit error rate was accounted with data pulses of 510 fs of FWHM and pump pulses of 610 fs. Using broader pulses, the conversion efficiency remained similar to the one obtained earlier due to the reduction in peak power which was compensated by the lower repetition rate of the signal. One of the most appropriate explanations of not getting the previous results at 1.28 Tbaud is the lower quality of data and pump signals in terms of timing jitter. However, using a 640 Gbaud signal, the timing jitter became negligible with respect to the width of the broadened pulses and hence no longer impaired the error rate.

CHAPTER 2

Literature Survey

Developments in very high bit rate light wave systems have been encouraged because of continuous demands for increased transmission capacity systems. Increased communication traffic have led to increase interest in multi giga bit per-second systems which have put a lot of stress on the requirement for high speed as well as wider band electronics in light wave systems. Previously it was possible to meet these demands because of high speed Si and GaAs circuits, but with increasing bit rates it has become quite difficult to develop the necessary digital electronic circuits. Several methods were realized by various scientists to overcome this electronic speed bottleneck by extending techniques of electrical multiplexing into the optical domain. Research mainly concentrated around two main approaches to optical multiplexing which were: optical wavelength division (or frequency division) multiplexing and optical time division multiplexing (OTDM). The time division multiplexing being a purely digital approach well suits with all digital networking . Optical time division multiplexing system designs have an adaptable bandwidth allocation in the distinct baseband channels. The capability of optical time division multiplexing and demultiplexing has been recognized for decades for high bit rate pulse code modulated systems . In recent times there have been system-level implementations at very high bit rates.

Tucker, *et al.* in July 2007 [64] experimentally demonstrated four channel optical time division multiplexed system. The bit rate used was 16 Gb/s. Principle of four channel, 16 Gb/s system has been stated. Here data has been transmitted over 8 km length of fibre achieving a bit error rate less than 10^{-9} . System crosstalk penalty of 1.9 dB was reported. On increasing transmission distance above 8 km additional penalty of 3.5 dB was encountered.

Rodney S. Tucker, *et al.* in November 1988 [65] demonstrated optical time division multiplexing (OTDM) and extended the eminent techniques of electrical time division multiplexing into the optical domain. They gave the concept that in OTDM, optical data

streams are formed from time-multiplexing a numerous low bit-rate optical streams. Wider scope in ultra speed transmission and switching were created by ousting limitations created by the limited bandwidth of electronics and by exploiting on the inherent high speed features of optical devices. In this paper an overview of optical time division multiplexing and demultiplexing were presented. Detailed design considerations affecting system were discussed with stress on factors that put constraints on system performance like crosstalk among multiplexed channels. Instances describing very high bit rate optical time division multiplexed system is presented using short pulses from mode locked semiconductor lasers and Ti: LiNbO₃, waveguide switch or modulators.

Takayuki Kurosu, *et al.* [66] in February 2013 proposed dynamic optical path switching in OTDM transmissions using bit rates of about 172 Gb/s for transmission of very high definition video signals. This system was integrated using semiconductor devices like CMOS based transceivers, quantum dot semiconductor optical amplifiers and monolithic optical gates. These all optical gates were formed on inter-sub-band transitions using quantum well waveguide. Optical null header was used to implement dynamically switchable OTDM (DS-OTDM) and a new clock distribution scheme was proposed. The optical null header helped in achieving channel identification as well as fast and robust clock recovery.

Deming Kong, *et al.* [67] further proposed 35 fs timing jitter clock recovery using electro absorption modulator and Mach-Zehnder modulator two-loop, providing simultaneous demultiplexing to permit 640 Gb/s OTDM transmission system over length of 400 km with power cost of 4 dB. Performance showed considerable progress compared with MZM-OEO clock recovery system. The dual-loop scheme used in a 640 Gb/s dual-polarization return zero QPSK OTDM system lessened the timing jitter of the 40 GHz recovery clock from 58 fs to 30 fs in back to back arrangement and then from 59 fs to 35 fs after travelling 400 km in 100 Hz to 10 MHz range with no growth in system complexity and cost. Implementation of the proposed scheme led to error free realization of the OTDM system after travelling 400 km transmission along with power penalty of 4 dB. With all these advantages this scheme had potential for high speed OTDM transmissions.

Shangjian Zhang, et al. in [68] experimentally demonstrated a novel self clocking using in-band phase-modulation pilot insertion and extraction for optical time division multiplexing (OTDM) signals. Realization of clock recovery was done by insertion at the transmitter end and extraction at the receiver end of an in-band phase-modulated pilot present in the data spectrum, eliminating requirement for an ultra fast phase comparator and a phase-locked loop in the receiver system. Simulation results showed the successful extraction of clock from 160 Gb/s OTDM data signal and demultiplexing of 40 Gb/s signal tributaries. Rapid synchronization, less timing jitters and stable recovered clock were the advantages of self-clocking which also imposes 1.5 dB of power penalty but an error free performance. The proposed method facilitates the designing of an OTDM receiver with minor modifications of the OTDM transmitter.

Arash Yazdani , et al. in July 2012 [69] studied the consequence of the clock signal's pulse width on the bit error rate of optical time division multiplexed (OTDM) networks. The receiver mentioned had a practical optical clock recovery and hence there was mismatching in time amidst the clock and data signals and this was termed as phase error. In this paper, the phase error was modeled as a Gaussian random variable with zero mean. Investigating this model, and using Gaussian pulses for the data and clock signals, the bit error rate of the receiver was analytically calculated. For obtaining results numerically, the bit error rate versus the clock signal pulse width was plotted for different values of phase errors for different bit intervals. At the end the system was simulated and compared using the analytical results and optimum pulse width value of the clock signal was obtained.

T. Kurosu, et al. in July 2012 [70] demonstrated stable transmission of uncompressed ultra-high definition (UHD) video signal by means of 344 Gb/s dual-polarization optical time division multiplexing (OTDM) with channel identifiable clock recovery. Amid the operation, performance of the system was observed through number of bits corrected by forward error correction and the peculiarity of the video on the screen. They noted that analysis by forward error correction count did not suffice since it was unable to count burst noise errors. A complete noise free video was observed on the screen. This was inferred because of absence of errors due to burst noise in the system. With received power greater than 2 dBm error free

operation was obtained. To obtain stability for some considerable amount of time the received power was reduced to 0 dBm and forward error correction count of 1 second was noted per unit time interval and bit error rate was analysed. With two polarizations the temporal difference in bit error rate was calculated for along with the eye diagrams of the demultiplexed signals. The clear eye openings were obtained depicting successful synchronous demultiplex operation.

Chi Zhang, et al. in 2012 [71] performed experiment and analysed simultaneous demultiplexing of 80 Gb/s optical time division multiplexed signal by translating it into wavelength division multiplexed idlers which were spaced by 1.15 nm by using swept-pump fibre optic parametric amplifier, and parametric gain nearly equal to 10 dB was obtained. They demonstrated an 80 Gb/s optical time division multiplexed signal demultiplexing using a swept-pump fibre optic parametric amplifier. Discrete fourier transform was used for obtaining pump source with the self phase modulated widened spectrum. The generated six wavelength division multiplexed channels with spacing of 1.15 nm had nearly 10 dB parametric gain. Because the swept-pump not being perfectly square four channels were demultiplexed with clean eye diagrams. The repetition rate of 80 Gb/s was subsequently increased by deploying dispersion flattened fibre along with larger swept pump range.

E. Palushani, et al. in January 2012 [72] also demonstrated technique of optical Fourier transform for performing serial to parallel conversion of 64x10 GBd optical time division multiplexed data signals using complex modulation formats for 50 GHz dense wavelength division multiplexed grid with no wastage of phase as well as amplitude information. It also proved that the technique of optical Fourier transform sustains the phase and amplitude information encoded over the changed OTDM tributaries. However, at 640 GBd the system did not act in accordance with forward error correction specifications. They also have suggested an improvement of performance in case of highly non linear fibre modules without walk-off. This technique was realized successfully for 160 to 640 GBd return zero, quadrature phase shift keying and 160 to 320 GBd return zero 16-quadrature amplitude modulation. It was successfully demonstrated that the serial-to-parallel conversion process protects the modulation format of the OTDM tributaries.

Masato Otsuki, et al. in 2012 [73] realized a phase stabilized quadruple optical time division multiplexing multiplier for return zero and carrier suppressed return zero optical clock. Using optical bandpass filter (OBPF) the desired sideband was filtered from the multiplier output and then this filtered output was used for the purpose of stabilization. 40 GHz was multiplied to 10 GHz optical clock with undesired sideband suppression ratio of 17 dB. They actually proposed stabilizing of phase in quadruple optical time division multiplexing clock multiplier and 160 Gb/s optical time division multiplexing. In this implementation, a tuneable wavelength continuous laser was used for the stabilization, which actually brought complications in the setup. Thereby, they came up with a new optical time division multiplexer without using a tuneable continuous wave laser. An OTDM optical clock multiplier was implemented. The proposed scheme was used to implement a quadruple optical clock multiplication.

Gordon K. P. Lei, et al. in August 2011 [74] demonstrated latest technique of reconfigurable demultiplexing of optical time division multiplexing (OTDM) signal. The operation was performed by using probing pulses obtained from interleaving of time and wavelength laser source pump through depletion in an optical parametric amplifier. Error free performance was achieved for both adjacent as well as alternate two-channel demultiplexing. Power penalties less than 0.6 dB was recorded. Successfully dropping of 10 Gb/s OTDM tributary signal was achieved from a 40 Gb/s multiplexed data signal with no errors and reconfigurable channel selection. Using interleaving of wavelength probing pulses the routing of demultiplexed channels to different destinations can further be performed. The advantage of this scheme was that it allowed fast reconfiguration using wavelength tuning rather than depending on difficult length adjustments in numerous delay lines. This system also had the advantage of upgrading itself to an OTDM-to-WDM converter when numerous pulsed channels are added.

H. Hu, et al. in July 2012 [75] realized optical time division multiplexing transmitter and receiver using a pulse source of 10GHz for a 640 Gb/s LiNbO₃ phase modulator. This was succeeded by a polarized independent double stage non linear pulse compressor. These

stages used self-phase modulation in dispersion flattened fibres which were highly non-linear. The good pulse quality assured no error in OTDM multiplexing and demultiplexing. The tuning of pulse source was possible from 1535 nm to 1560 nm, radiating a 680 fs Gaussian pulse with very little pedestal at all other wavelengths. The pulse source is deployed in a 640 Gb/s on-off keying optical time division multiplexing data production and demultiplexing experiment, where no errors in bit error rate performance confirmed the good pulse quality. The non linear optical loop mirror was used for OTDM demultiplexing of the 640 Gb/s serial data signal into a 10 Gb/s data signal using cross-phase modulation in a 50 m long highly non linear fibre with 10 GHz control pulses at wavelength of 1559 nm.

Johannes Karl Fischer, *et al.* in February 2012 [76] realized a 8×448 Gb/s polarization division multiplexing sixteen-ary quadrature AM-WDM signal with spectral efficiency 4 b/s/Hz is produced by optical time division multiplexing and real time FPGA based formation of four level in phase and quadrature phase modulator steering the signals. Transmission performance over length of 250 km ultra large area fibre with EDFA amplifier-only amplification was analysed. Eight WDM channels were transmitted over a 250 km length of in-line fibre link which consisted of universal line access family (ULAF). The spacing of 100 GHz WDM channel achieved spectral efficiency of around 4 bit/s/Hz. They also had investigated transmission of 56 GBd polarization division multiplexed 16-quadrature amplitude multiplexing wavelength division multiplexed channel signals on the ITU-T, 100 GHz channel grid having spectral efficiency of about 4 b/s/Hz over a length of 250 km fibre link with EDFA only amplification.

Antonella Bogoni, *et al.* in the year 2011 [77] demonstrated the efficacy of a periodic poled Lithium Niobate waveguide for performing extraction of channel as well as clearing from time interleaved optical pulses. The periodic poled Lithium Niobate waveguides being used at room temperature creates huge interest and also since it reduces the power usage. Also they confirmed that each of the operation requires one periodic poled Lithium Niobate waveguide timely optimized and simultaneous operations are not possible within a single waveguide. It was also reported that on implementation of a 640 Gb/s reconfigurable OTDM add/drop multiplexer, a single periodic poled Lithium Niobate waveguide can be used. This

ROADM (reconfigurable OTDM add/drop multiplexer) acting in the time domain carried out channel extraction along with clearing and insertion for OTDM signal with a single wavelength and also for a WDM comb of channels optical time division multiplexing. They also showed that simultaneous add/drop can be carried out with an opposing propagating arrangement in a single periodic poled Lithium Niobate waveguide. Also reconfigurable performance were verified using bit error rate (BER) measurements together with the case of add/drop of one or more channels in the optical time division multiplexing frame. These results showed a many fold enhancement in complications and reconfigurability through a single nonlinear element for ultra-fast time domain multiplexer used in high capacity optical communication networks.

Nan Jia, et al. in November 2011 [78] implemented a technique for performing optical time division multiplexing with consecutive clock enhancing and also demultiplexing using two electro-absorption modulators (EAMs) that were operated bi-directionally. The performance of the projected unit was tested experimentally in a 160 Gb/s, 100 km length transmission system. The up gradation of 10 GHz clock was done by inducing the clock recovery module. The improved 10 GHz clock signal was shown with low timing jitter and no errors in the transmission but power penalty of 0.9 dB. The proposed setup had the advantages enhancing base clock along with demultiplexing.

H.C. Hansen Mulvad, et al. in July 2011 [79] came up with a technique for dense wavelength division multiplexing optical time division multiplexing conversion using time domain optical Fourier transform which allowed concurrent conversion of all channels by using a 1 four wave mixing switch. This technique was successfully implemented by conversion of a synchronized 16×10 Gb/s dense wavelength division multiplexing data signal with 50 GHz spacing among channels to a 160 Gb/s optical time division multiplexing (OTDM) signal with 6.25 ps signal spacing. The bit error rate performance showed no error with average conversion penalty of about 2.1 dB.

H. Hu, et al. in July 2011 [80] showed that an Ethernet packet having maximum standard size of 1518 bytes was capable of being synchronized and retimed to a master clock having frequency offset of 200 kHz and simultaneously their format can be converted from non-return-zero to return-zero. Further, the synchronized return zero Ethernet packets were pulse compressed with multiplexing in time with a 640 Gb/s optical time division multiplexing signal having an unoccupied time slot, and then to added 650 Gb/s serial signal respectively. Performance of synchronizing, retiming, multiplexing was achieved error free using a 640 Gb/s optical time division multiplexing signal and ultimately demultiplexed 10 Gb/s of this Ethernet packet was obtained.

Miguel V. Drummond, et al. in July 2011 [81] had proposed and experimentally demonstrated an optical time division multiplexing to wavelength division multiplexing converter enabled by a programmable optical processor. Performance was analysed over converted signals at 40 Gb/s with a highest power penalty of 6.3 dB. Also, intermediate rate (80 Gb/s) conversion was experimented. The anticipated system presented important advantages like wavelength tuning ability of the channels that were WDM converted, random OTDM signal to WDM channel aligning and modulation format simplicity. These benefits are needed in advanced optical networks using different types of multiplexing schemes, and also flexibility in frequency grid and superior modulation formats have higher spectral efficiency.

Sanmukh Kaur and R.S. Kaler in 2013 [82] described a symmetric semiconductor amplifier and Mach-Zehnder interferometer as switch for performing demultiplexing. Further the operation of return-to-zero and non-return to zero modulated signals was demonstrated in all optical demultiplexing of an optical time division multiplexed channel extending for data rates up to 160 Gb/s. The effect of input signal power, control signals power and pattern length on bit error rate and extinction ratio of demultiplexed channel was researched for return zero and non return zero signals at various data rates. Also demonstration of demultiplexing of optical time division multiplexed signal at data rate of 160 Gb/s signal to the base rate of 40 Gb/s was effectively performed with no error in both of the modulation

formats. Variation of pulse width on bit error rate has also been examined for 160 to 40 Gb/s demultiplexing.

2.1. Dissertation Scope

Growing demands for greater capacity has accelerated the development of ultra high speed optical shared media networks. Ultrafast optical time division multiplexed (OTDM) networks having single wavelength channel rate above 100 Gb/s provides easy management and adjustability as well as capability to offer accurate flexible bandwidth in application based services, packet switching and scalability among multiple users. In recent times, the mainstream of research on ultrafast optical networks is concentrating on device technology based implementations such as all optical logic using optical time division multiplexing rates, short pulse optical sources with higher repetition rate, self-synchronization techniques, wavelength conversion and long distance propagations. Even though the amount of optical time division multiplexing system implementations has been narrow but considerable advancements like single bit and multiple bit all optical address assessments and packet routing at optical time division multiplexing rates and receiver slot self-synchronization, promises great future for OTDM application. Higher bit rate OTDM have attracted great applications since single wavelength can accommodate greater payloads. Increased internet traffic has caused increasing demand for higher data rate in wireless communications in order to match the pace of remarkable speed of fibre optic networks such as Ethernet LANs.

2.2. OptiSystem 7.0

OptiSystem is an innovative contemporary optical communication system simulation package which was designed by Optiwave Company for the purpose of meeting the academic requirement of the system designers, optical communications engineers, and researchers. It assimilates designs, test and optimizes all types of broadband optical network physical layer functions like virtual optical connection. From long distance communication systems to LANs and MANs, it can be well used anywhere. It has a huge database of active and passive components, including power, wavelength, loss and other related parameters. Parameters allow the user to scan and optimize device-specific technical parameters on the

system performance. OptiSystem has powerful simulation environment and real components and systems of classification definitions. A fibre optic communication system model is based on the actual system level simulator. Its performance can be attached to the device user interface library and can be completely expanded to become a widely used tool. OptiSystem meets the booming market requirements and is fast becoming a useful tool for various design simulations.

2.2.1. Minimum System Requirements for OptiSystem

Operating System	Processors	Disk space	RAM
32 bit optiwave			
Windows XP (Service Pack 2 or higher) Windows Vista (SP1) Windows 7™	Intel Pentium III processor (or higher) AMD Equivalent	350 MB	512 MB (2 GB recommended)
64 bit optiwave			
Windows XP x64 (Service Pack 1 or higher) Windows Vista x64 (Service Pack 1 or higher) Windows 7 x64	Intel or AMD processors including: Intel Dual Core, Core 2, Intel Xeon, AMD64 multi-core, i7, Intel Core 2 Quad (i.e. currently manufactured processors)	350 MB	1024 MB (4 GB + recommended)

Table 2.1: Table showing basic requirements for running OptiSystem [8].

2.3. Objectives of Dissertation

- 1.) To design the Ultrafast OTDM using Optical Delay Line Structure Technique.
- 2.) To study and compare the different transmission formats in terms of bit error rate, spectrum of the modulation formats and quality factor through eye diagrams and BER.

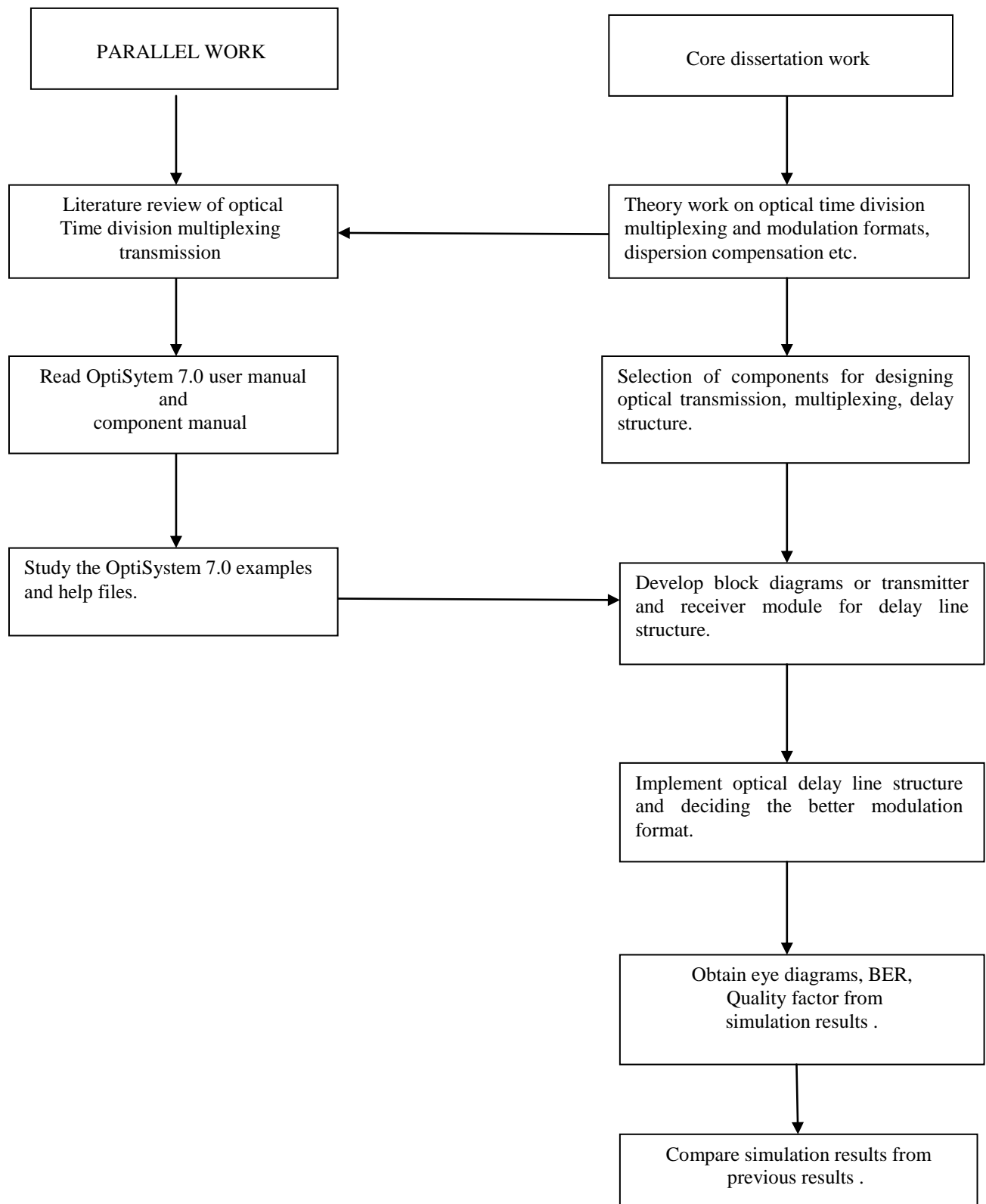

Figure 2.1: Dissertation frame work.

CHAPTER 3

Design of Ultrafast OTDM using Optical Delay Line Structure Technique

3.1. Introduction

Our future networks should be capable of carrying several types of traffic in a dynamical manner. Optical networks have the capability to provide high bandwidth for future bandwidth intensive applications. Here, an ultrafast packet interleaved optical time division multiplexing network is designed for high dynamical and high capacity photonic networks. Optical Delay Line Structure is thereby designed, achieving a high bit rate access to the optical medium on a packet by packet basis. The results are simulated and are presented to demonstrate the effectiveness of the proposed design.

Recently, many methods for optical rate conversion (optical packet compression and expansion) have been proposed [8-9]. Many of them are based on an optical buffer (optical recirculation loop) and sampling techniques. But this technique offers restrictions on the bit rate and packet size. The restrictions are due to difficulties in buffering of ultra high speed large optical packets for large period since it causes optical impairment due to dispersion and amplified spontaneous emission (ASE) noise accumulation during amplification [14]. Delay line structure is a further technique for optical packet compression. This technique allows simultaneous compression and expansion of n bit large optical packets using same device for compression as well as expansion.

3.2. Background

Basically, there are two ways in optical domain for switching up of signals: WDM technique and OTDM technique. The use of OTDM is more suitable due to limited switching technologies available in WDM. Many research scientists are applying ultrafast OTDM to photonic networks. An example of network that incorporates OTDM for the transmission of ultra high capacity data on single optical wavelength is Packet Switched Optical Network. This networks operates on single wavelength optical packet with high bit rate. The primary

advantage of this network is optical packets sent are converted into electrical domain when they finally reach their destination. Since electronic conversion is avoided at the intermediate nodes hence one can use fibres bandwidth efficiently and reduce switching latency [5].

This research work presents an optical packet compressor for compressing optical time division multiplexed data. Streams up to 1 Tb/s packet bit rate can be compressed. Also we can use the same structure for optical packet decompression in order to extract ultra high data rate OTDM packets when they reach their destination. Most important aspect of design presented in this work is exploitation of bidirectional capability of fibre optic, that is, optical delay line lattice can be used for compression and decompression simultaneously. This reduces cost and complexity since same optical delay line performs multiple functions [1-3]. Several authors have proposed bandwidth compression in literature using OTDM technique. Ming Chen *et. al* [10] has proposed spectrum compression based on filters for demonstrating bandwidth efficiency and has demonstrated 40 Gb/s OTDM system experimentally. Evarist *et. al* [16] has proposed a scheme enabling serial to parallel conversion of OTDM data onto WDM grid based on optical Fourier transformation with spectral compression. In [8] a simple and robust short pulse source based on chirp compression scheme is proposed.

Here design structure for the compression of 1 Tb/s optical packets is demonstrated, the setup as shown in figure 3.1 is constructed. Hence bandwidth was conserved to a great extent.

3.3. Proposed Optical Delay Line Structure

The optical packet compressor using an ODLS, an optical gate and fibre optic system is shown in figure 3.1. This structure allows compression of packets to be transmitted simultaneously with the decompression/expansion of received packets using the same structure. Number of compression stages used increases logarithmically with the number of bits to be processed [15]. The maximal packet size $L_{p,max}$ is limited by the compression rate K as follows:

$$L_{p,max} = K - 2 \frac{t_{gate}}{\tau_o} \quad (1)$$

where $K = \frac{T_o}{\tau_o}$ is compression rate, t_{gate} denotes the response time of the optical gate and T_o and τ_o are the bit periods of low and high speed signal, respectively. For $K = 100$, $\tau_o = 10$ ps and $t_{gate} = 40$ ps, $L_{p,max}$ is limited to 91 bits. However such short packets are usually impractical in many of the applications and also large rate conversion time can impair the performance. Since the complete compressed packet occurs in the gap between two bits of signal of low speed, the number of bits in the packet is limited by compression rate K as:

$$n < K - 1 \quad (2)$$

If we take into account t_{gate} as response time of gate then the limitation on size of packet is given by

$$L_{p,max} = K - 1 - 2 \left\lceil \frac{t_{gate}}{\tau_o} \right\rceil \quad (3)$$

For large packet sizes, large compression rate or parallel arrangement of ODLS is used. The principle of operation of an optical packet rate conversion unit based on optical delay line structure can be explained using figure 3.1 and figure 3.2. In this figure 3.1, ODLS consists of 3 stages. All stages consist of 3 dB coupler and a delay line.

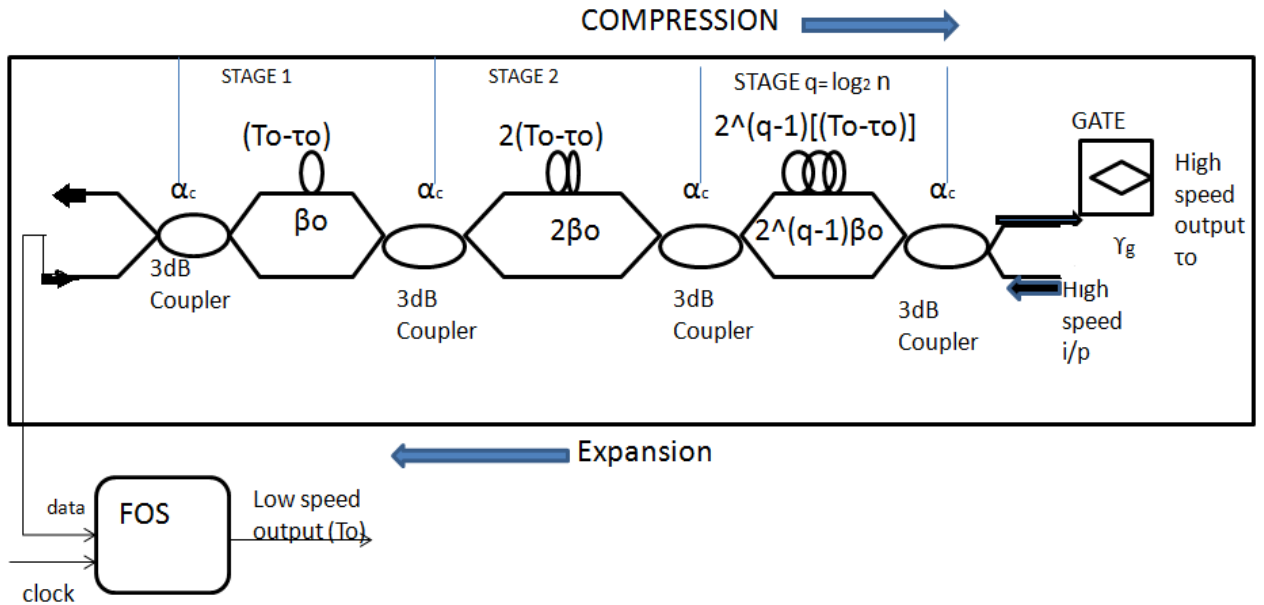

Figure 3.1: Packet Compressor / Expander using ODLS [14].

As seen from figure 3.1 compression operation, a low speed six bit input packet is first split by the two arms of 3 dB coupler. In the first stage the signal in the upper arm is delayed by $(T_o - \tau_o)$ and it is then combined with the undelayed packet in the next coupler. The resulting signal is once more delayed in the second stage by $2(T_o - \tau_o)$ and similarly third stage. At the output, each of the input pulse is then copied six times and is spaced from its neighbour pulse by $(T_o - \tau_o)$. The complete compressed packet is then selected by optical gate at the output of delay line structure which is in the middle of output sequence.

Now if we add an additional fast optical switch, the expansion of the high speed packets can be achieved using the same device but in opposite direction. The high speed optical packet enters high speed input port of the device. This packet is delayed by the delay line in the upper arm and combined by a 3 dB coupler in each of the stage with the undelayed signal, making six copies of high speed input packet at output of ODLS. Each copy is delayed by $(T_o - \tau_o)$ with respect to next copy. An ultrafast optical switch selects, the bits which are spaced at a bit period by T_o , in a considerable narrow switching window. Thus, the decompressed low speed output optical signal is received having same bit pattern sequence as the compressed packet.

3.4. Simulation Setup:

The optical delay line structure was demonstrated using OptiSystem 7.0. This was formulated keeping in mind the block diagram as shown in figure 3.1. Here data stream externally modulates periodic train of narrow pulses. Since the bit interval is T , successive separation between pulses is also T . We have tried to reduce the time interval between adjacent pulses to generate a high rate multiplexed signal. This operation is performed by passing of the initial sequence through a chain of compression stages.

Assuming the size of each packet to be L bits, the output is passed through K compression stages. Given that,

$$K = \log_2(L) \quad (4)$$

Figure 3.2 shows basic block diagram for our optical delay line structure where each of the stages provides a delay to the transmitting pulses. Implementation of each of the compression stage is done in a subsystem as each stage was having the same layout.

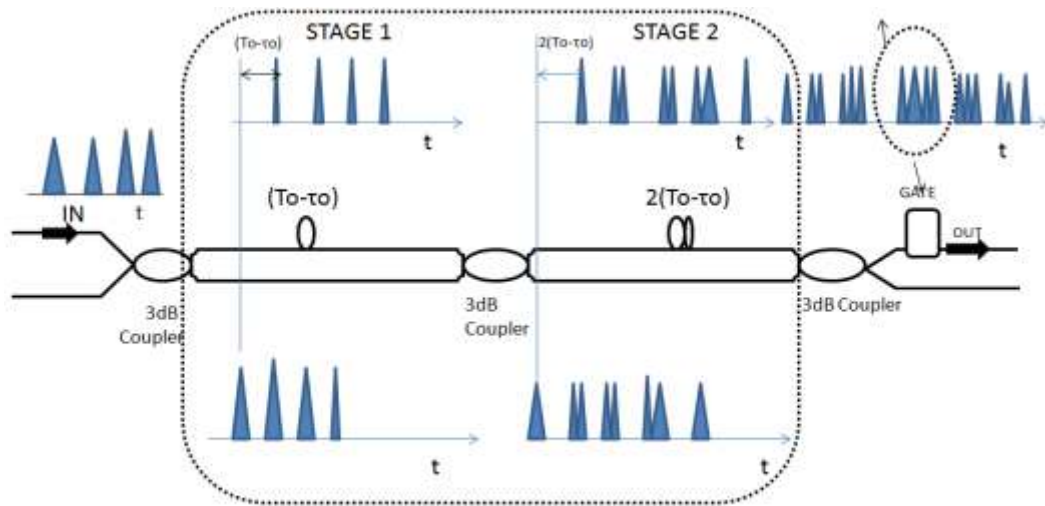

Figure 3.2: Block diagram for Optical Packet Compression Operation for 4 bit packet [14].

The basic difference among the compression stages were parameters like bit rate at the pseudo-random bit sequence generator along with the delays at the time delay component.

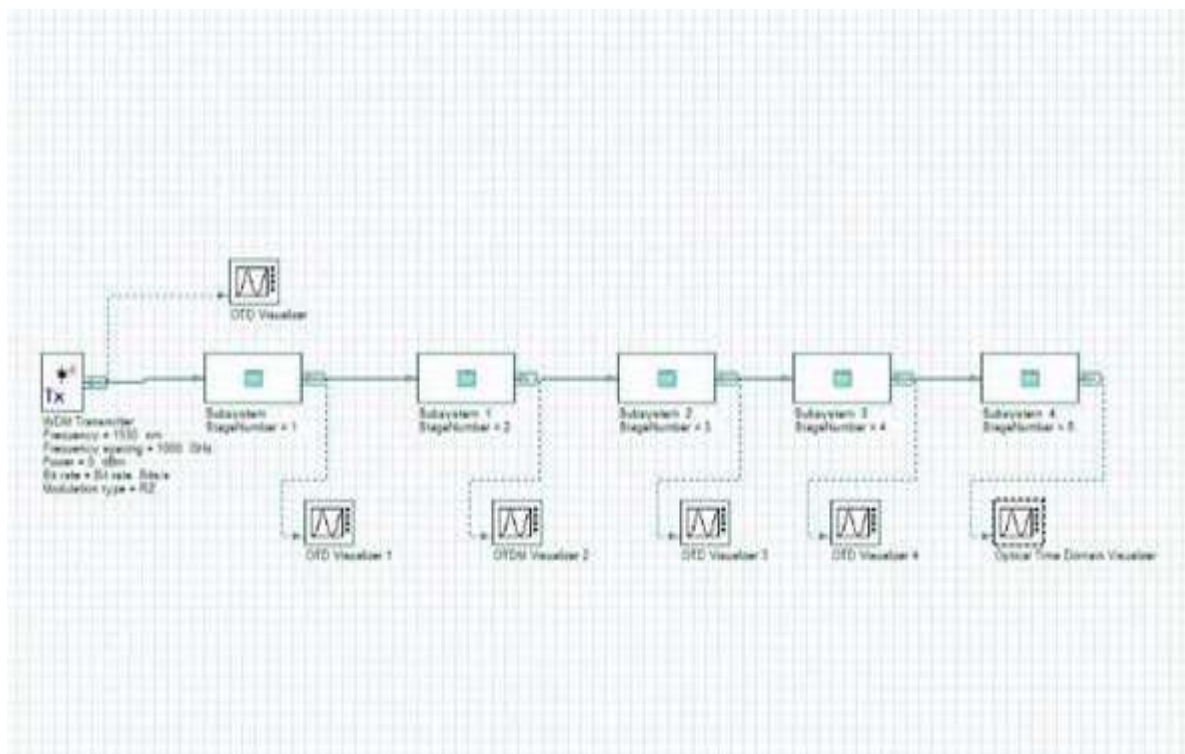

Figure 3.3: Basic ODLS layout.

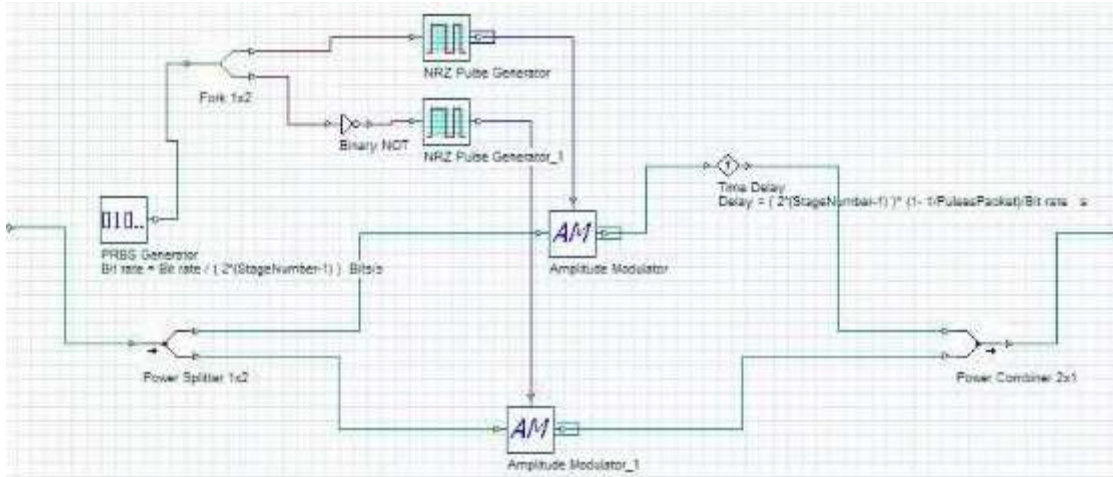

Figure 3.4: Layout of compression subsystems.

3.5. Results and Discussion

To demonstrate the capability of simultaneous packet compression and expansion, optical packets with a bit rate of 1 Tb/s have been taken and the setup has been as shown in figures 3.3 and 3.4. A 1550 nm continuous wave laser is used to generate optical pulses of power 0 decibels and line width 10 MHz. A five stage fibre optic delay line is used ($n = 32$) for the expansion and compression of 32 bit data packets. A data pattern has been generated arbitrarily which is then encoded onto the optical pulse stream generated by CW laser using Amplitude modulator (Mod1) and then this encoded packet is passed onto ODLS subsystem where it has been compressed. A second modulator is then used at the output of the delay line to get the compressed packet. The packet after passing through all the compression stages (here 5 compression stage) has been amplified by the amplifier and is passed through 6 nm optical band pass filter (BPF) in order to remove ASE (amplified spontaneous emission) and is propagated over 1000 m length of optical fibre. This optical packet is then again injected into the delay line lattice but in backward direction. A demux has been used to extract the bits from the compressed packets. Finally the decompressed packet can be seen on oscilloscope after passing through a low bandwidth photo detector.

As shown in the experimental setup we were able to compress and decompress 32 bit, 1 Tb/s optical packets as illustrated in figure 3.3 and 3.4. Figure 3.5 (a) shows the 1 Tb/s packets before compression with bit sequence 10110100. After compression stages the packet has

been detected a photo detector and an oscilloscope. Figure 3.5(b), 3.5(c) and 3.5(d), 3.5(e), 3.5(f) shows the output after each of the first, second, third and fourth compression stages.

PARAMETERS OF TRANSMITTER:

Frequency	1550 nm
Frequency Spacing	100 GHz
Power	0 dBm
Bit rate	1 Tb/s
Modulation Type	RZ
Extinction Ratio	100 dB
Pulse Time	0.06 bit
Pulses Packet	32 bits per packets

Table 3.1: Parameters for transmitter.

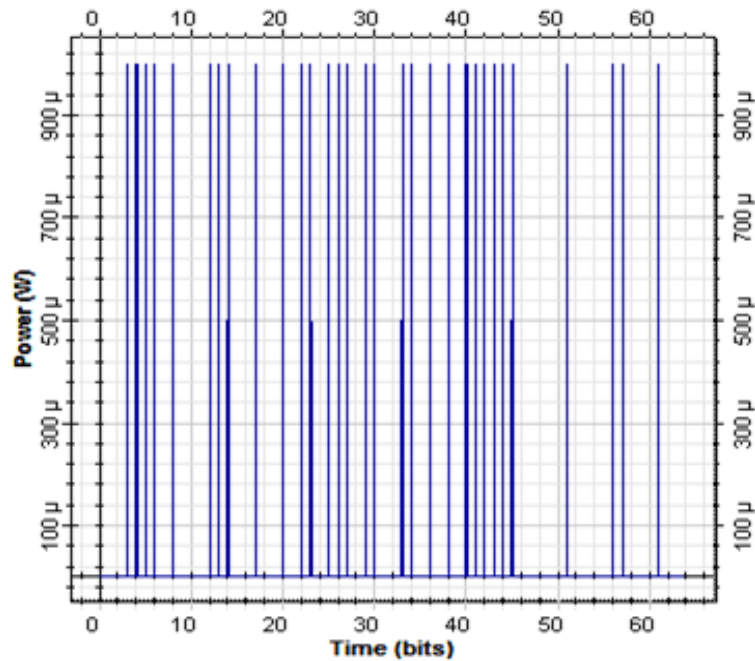

Figure 3.5(a): Initial pseudo-random bit sequence.

Figure 3.5(a) above shows the initial bit sequence which is pseudo random and has not been passed through any of the compression stages.

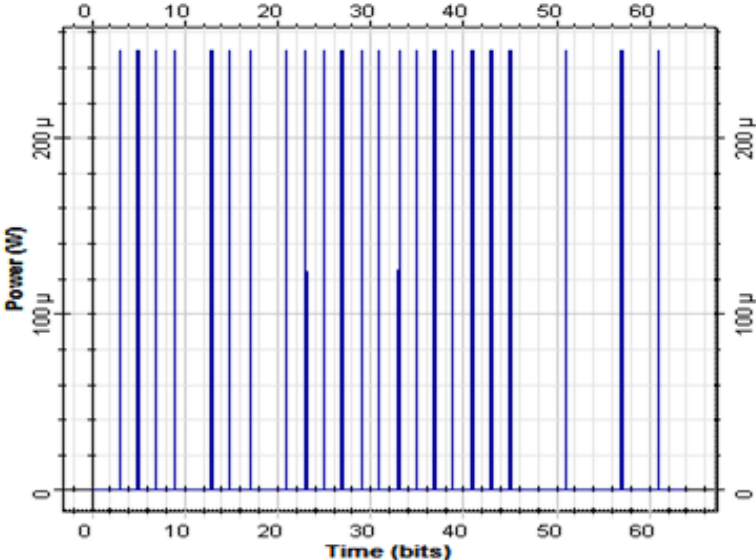

Figure 3.5(b): Output after passing through first compression stage.

Figure 3.5 (b) shows the bit sequence after passing through the first compression stage. Pulse width τ we have taken as 0.06. We have taken 32 bits per packet. Bit interval is 1 bit. Now after passing through the first compression stage there is a delay of $(T - \tau)$, i.e., delay of 0.94 is by one arm and it is combined with undelayed signal and the compressed output is as shown above.

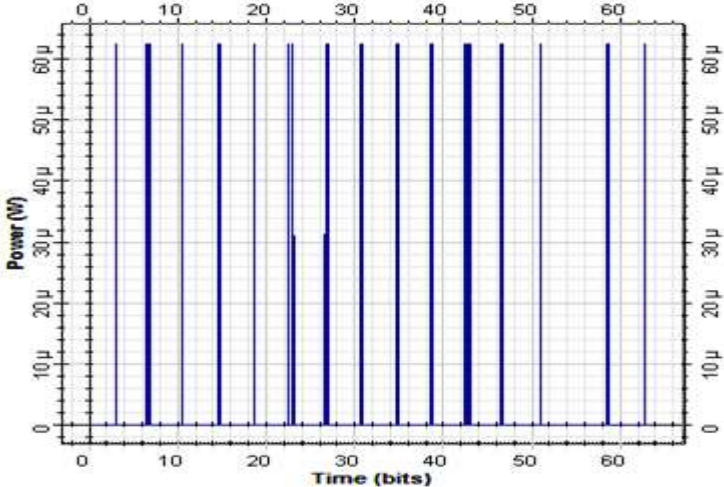

Figure 3.5(c): Output after passing through second compression stage.

Figure 3.5 (c) shows the sequence after passing through second compression stage. A delay of $2(T-\tau)$ is provided in the second compression stage, i.e., delay of $2*(0.94) = 1.88$.

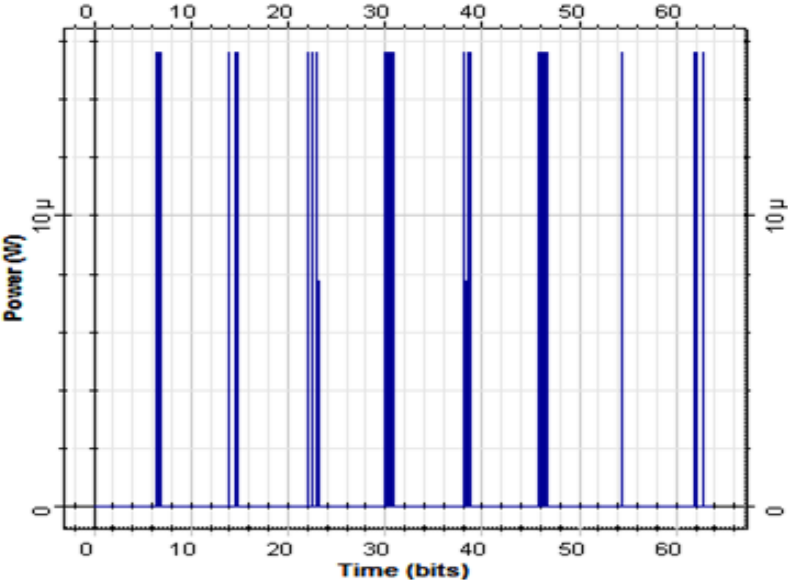

Figure 3.5(d): Output after passing through third compression stage.

Figure 3.5(d) shows the output after being passed through third compression stage. This stage provides a delay of $3*(T-\tau)$, i.e., $3*(0.94) = 2.82$.

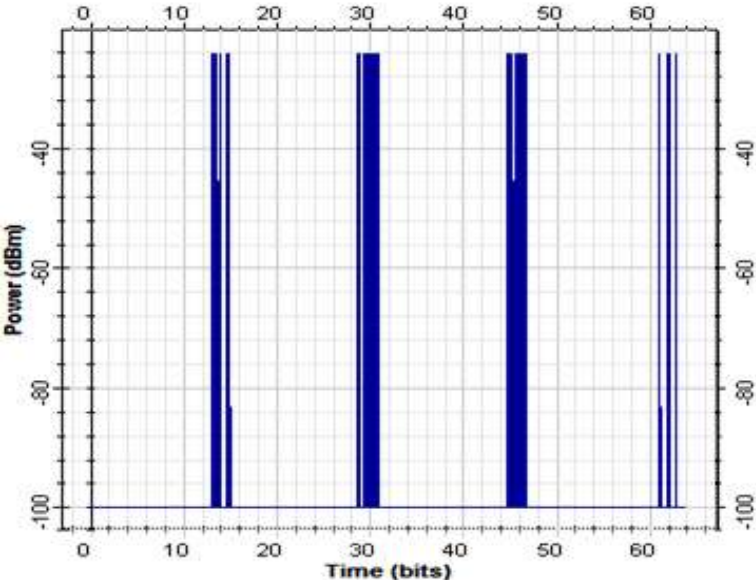

Figure 3.5(e): Output after passing through fourth compression stage.

Figure 3.5(e) shows the output after being passed through fourth compression stage. This stage provides a delay of $4*(T-\tau)$, i.e., $4*(0.94) = 3.76$.

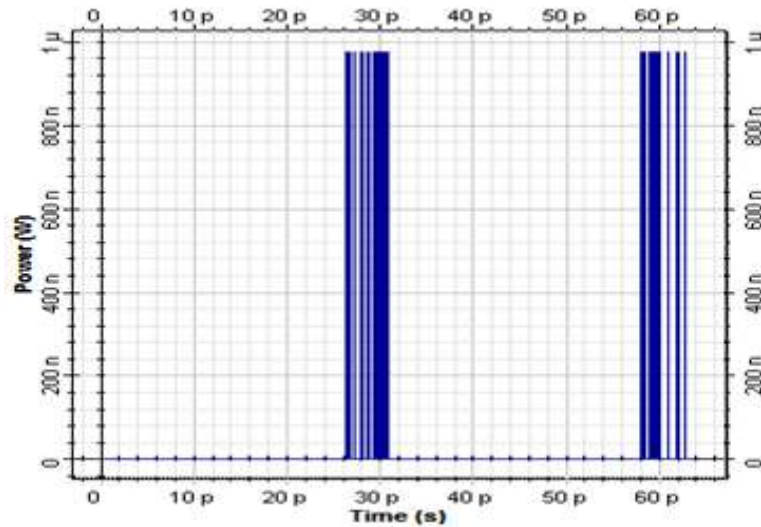

Figure 3.5(f): Final compressed output.

Figure 3.5(f) shows the final compressed output after being passed through fifth compression stage. This stage provides a delay of $5*(T-\tau)$, i.e., $5*(0.64) = 3.2$ and the final compressed output is as shown above in fig 3.5(f).

3.6. Conclusion

Using optical delay line structure we were able to compress data at a bit rate of 1Tb/sec so as to reduce the overall bandwidth. The biggest advantage of using optical delay line structure is one can perform compression and expansion simultaneously. Also this structure can be used for packets with practical sizes because delay line increases logarithmically with the number of bits to be processed. If we take example of 64 byte packet (large enough to hold ATM cell) then it would require 9 compression stages. Also splitting losses can easily be compensated by using a single amplification stage. High bit rate of more than terabit per second range can be used which would be needed due to fast growth of internet traffic demands as well as supercomputer applications.

CHAPTER 4

Performance Evaluation of CSRZ and Duo-Binary Modulation Formats.

4.1. Introduction:

With the ever increasing advancements and demand for high capacity optical networks, ultra high bit rate transmission has acquired an integral part of high speed communication system. Here we have tried to analyse the performance of communication system using advanced modulation formats of carrier suppressed return zero and duo-binary techniques at high bit rate. Upon working with various kinds of modulation formats, it is envisaged that using novel modulation formats enhance the aggregated performance of the optical communication systems at high bit rate. Thus the two modulation formats: Carrier suppressed return to zero (CSRZ) and duo binary modulation format at 50 Gb/s for the optical communication system is studied and analysed.

Modulation format plays a vital role in fibre optic communication system determining transmission quality of the transmitted data signal. Modulation formats not only determines quality of transmission but also affects parameters like optical spectral bandwidth, nonlinear crosstalk resistance, resistance to chromatic dispersion, vulnerability to accumulated noise as well as other system performance parameters are directly affected by the optical modulation format. Now a days, researches on advanced optical modulation formats are encouraged for high transmission capacity as well as better system reliability. Advanced and better selection of an optical modulation format does perk up the system's performance. The preference of most advantageous optical modulation format depends on a variety of factors like data rate, type of fibre used, wavelength spacing etc. Here we have presented performance evaluation of optical intensity modulation formats at optimum data rates.

4.1.1. Modulators

Modulation is a process in which information is imposed onto the light wave. In this technique the base band signal avails carrier signal of very high frequency in order to be

more suitable for transmission over long distances. Modulation techniques are divided into two categories: direct modulation and external modulation.

4.2. Intensity Modulation Formats

4.2.1 Carrier-Suppressed Return to Zero (CSRZ)

CSRZ modulation is often said to be pseudo-multilevel modulation format. Here the sign of the optical field is reversed at each bit transition. Unlike correlative coding formats such as duo binary, the sign reversals here takes place at every bit transition and is purely independent of the data carrying part of the signal [5]. CSRZ is a special type of RZ in which the carrier is suppressed. CSRZ format minimizes the nonlinear impairments in the channel and upgrades the spectral efficiency of high bit rate systems. Difference between CSRZ and RZ is that the CSRZ signal has π phase shift amid adjacent bits. Hence phase alternation, in the optical domain, do not produce direct current element thereby resulting in no carrier component for CSRZ. The fundamental frequency components are reduced to half of the data rate because of phase alternation amid adjacent bit slots. Also CSRZ gives improved endurance to chromatic dispersion because of lower optical power, giving space for more channels multiplexed in transmission. Additionally, carrier suppression minimizes the efficiency of four wave mixing in wavelength division multiplexed systems as well [21].

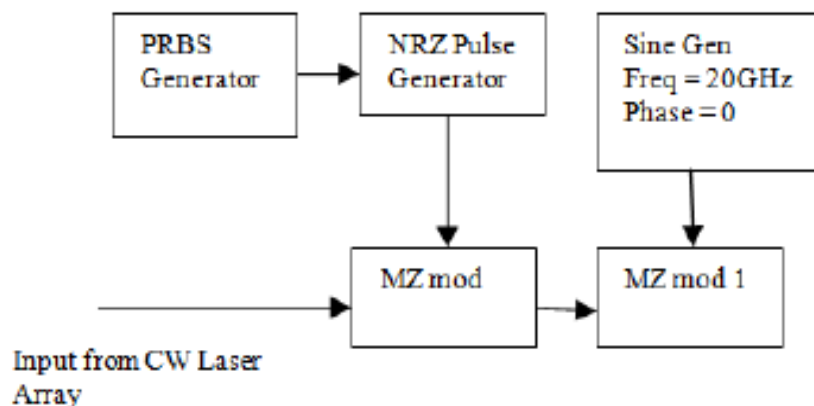

Figure 4.1: Block diagram of CSRZ transmitter [12].

The block diagram of the CSRZ transmitter is depicted in above figure 4.1. To generate CSRZ optical signal electro-optic modulators are required as shown in this figure. The first Mach Zehnder modulator encodes the non return to zero data. Subsequently the generated non return to zero optical signal is modulated by the second, Mach Zehnder modulator to produce a CSRZ optical signal [17].

4.2.2. Duo Binary Modulation Format

One of the categories of intensity modulated signals is called as partial response signals. These partial response signals are same as CSRZ in considering the factor that some bits are flipped in phase with respect to the other bits. Partial response coding signifies that these phase flips are positioned in accordance with the transmitted bit pattern. Therefore these partial response signals need an extra coding layer and various drive electronics than CSRZ. Duo binary is a particularly important partial response code in optical communications .Duo-Binary has many attractive features which make it beneficial in certain situations. Duo-Binary is also a near perfect modulation format for high spectral efficiency systems and metropolitan area networks.

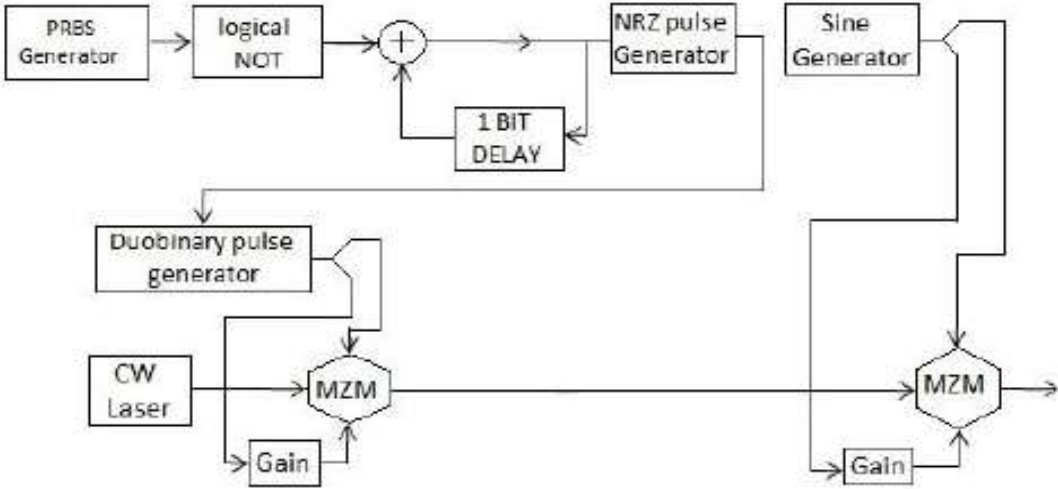

Figure 4.2: Generation of duo binary modulation format [32].

Figure 4.2 depicts the generation of duo binary modulation format. For generation of duo binary modulation format electrical non-return to zero signals are pre-coded in an encoder

which is basically EXOR circuit. Then by using band-limiting electrical filters, these already coded binary signals are converted to 3-level duo binary signals. The transmission part consists of amplifiers, filters and splitter. The receiver is of ASK type.

4.3 Simulation Setup and Results:

For duo binary modulation format, a continuous wave (CW) laser is used at transmitter side. LiNb Mach Zehnder modulator modulates the random sequence generated by pseudo random sequence generator using CW laser. The modulated signal is passed through another LiNb Mach Zehnder modulator connected in series to the first one. A sine wave from a sine wave generator and an inverted sine wave is used which is passed through this second Mach Zehnder modulator along with the previous modulated signal. Now this is passed through a series of EDFA's amplifier travelling a length of 50 km of single mode fibre. A dispersion compensated fibre of length 10 km is used. Now this is passed through PIN photodetector and low pass Bessel filter to analyse bit error rate.

In case of duo binary signal generation, the random sequence of generated bits is inverted and is passed through a pre-coder of delay 1 bit. This pre-coded bits and NRZ pre-coded bits are then passed through duo binary pulse generator. Now this generated signal is modulated by Mach Zehnder modulator along with CW generated signal. Again as in CSRZ another LiNb Mach Zehnder modulator is connected in series that modulates sine wave, inverted sine wave and output of the first modulator. This modulated signal is then passed through series of EDFA's, single mode fibres and dispersion compensation fibres and is finally detected by a PIN photodiode receiver. The output from low pass Bessel filter is then analysed for bit error rate.

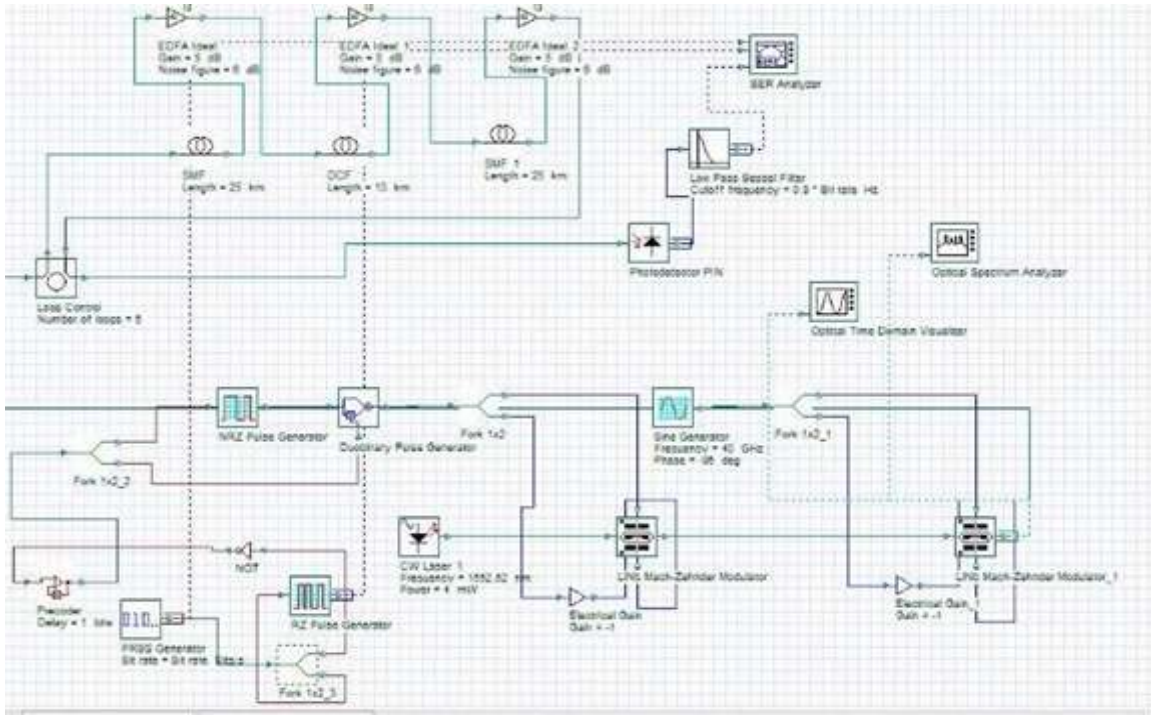

Figure 4.3: Layout of Duo Binary modulation format.

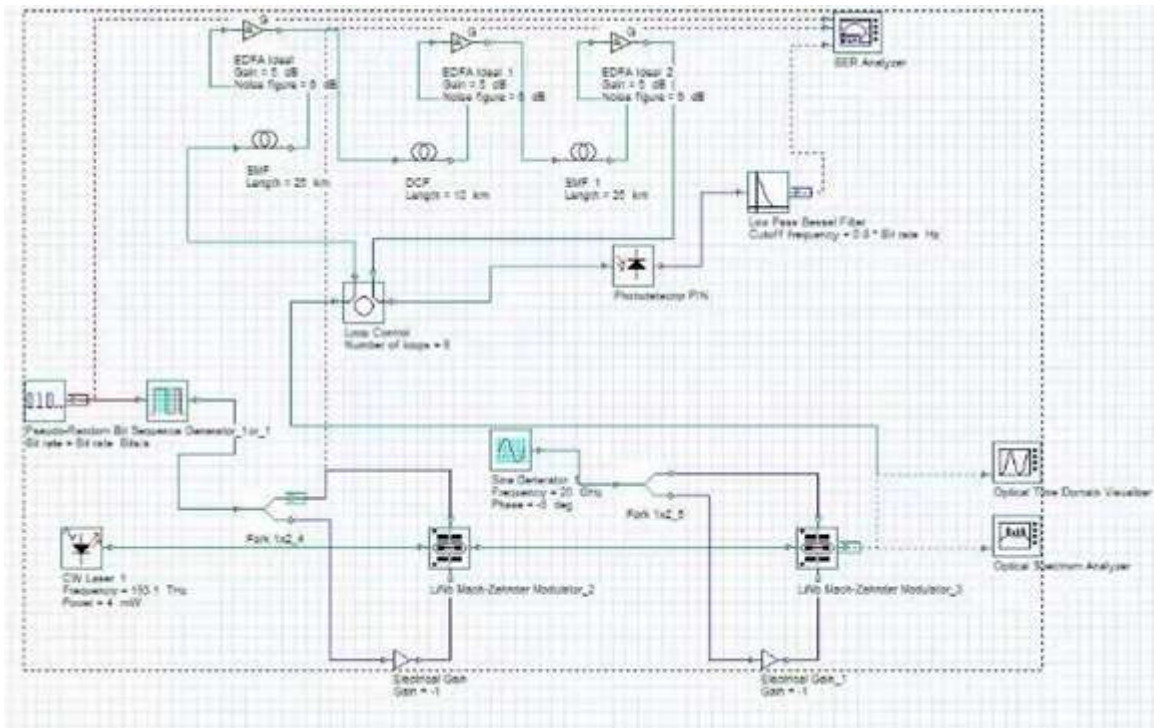

Figure 4.4: Layout of CSRZ format.

Parameters for CSRZ:

CW Laser frequency	193.1 THz
CW Laser power	4 mW
Extinction ratio of MZM_1	100
Extinction ratio of MZM_2	50
Sine Generator Frequency	20 GHz
Sine Generator Phase	-5 deg
SMF length	50 km
EDFA Noise Figure	6 dB

Parameters for Duo Binary:

Bit Rate	60 Gb/s
CW Laser Frequency	1550 nm
CW Laser Power	4 mW
Extinction ratio of MZM_1	50 dB
Extinction ratio of MZM_2	50 dB
Sine Generator frequency	40 GHz
Sine Generator phase	-95 deg
SMF Length	50 km
EDFA Noise figure	6 dB

Table 4.1: Parameters for various components of CSRZ and Duo Binary, modulation format.

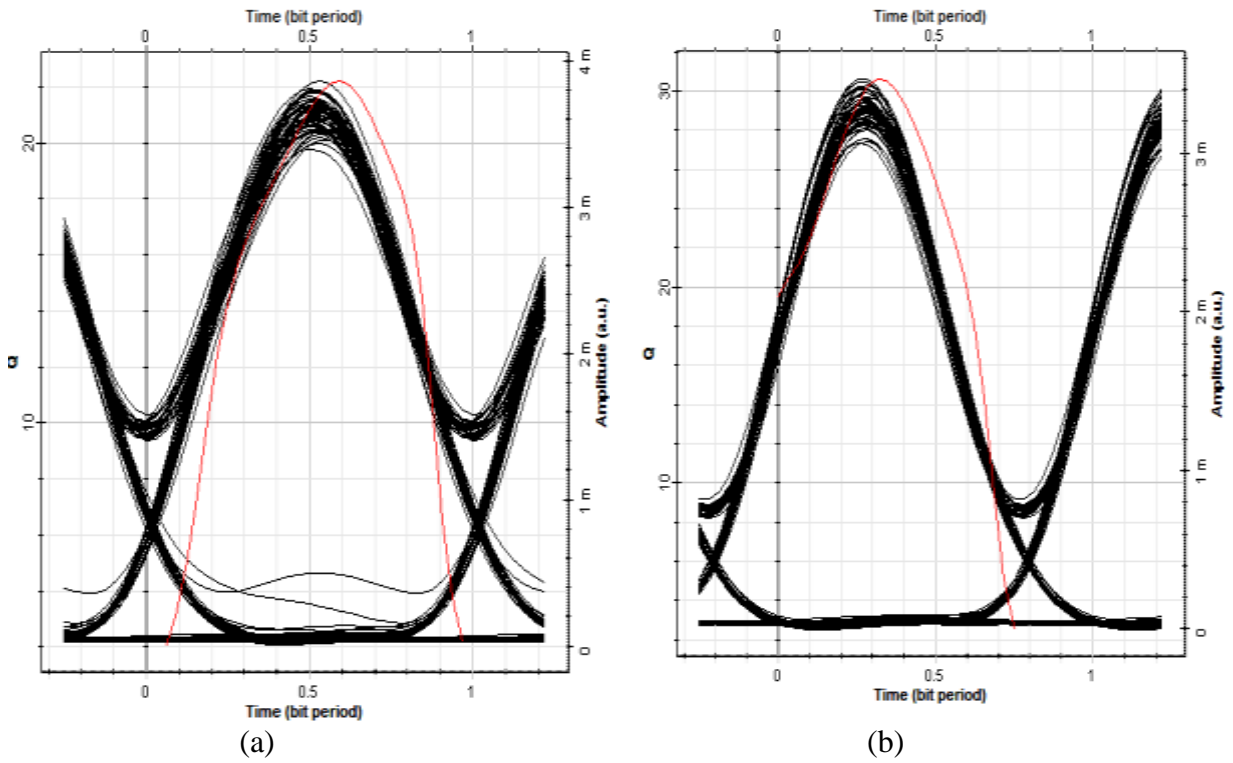

Figure 4.5: Eye diagrams for (a) CSRZ (b) Duo binary, modulation formats.

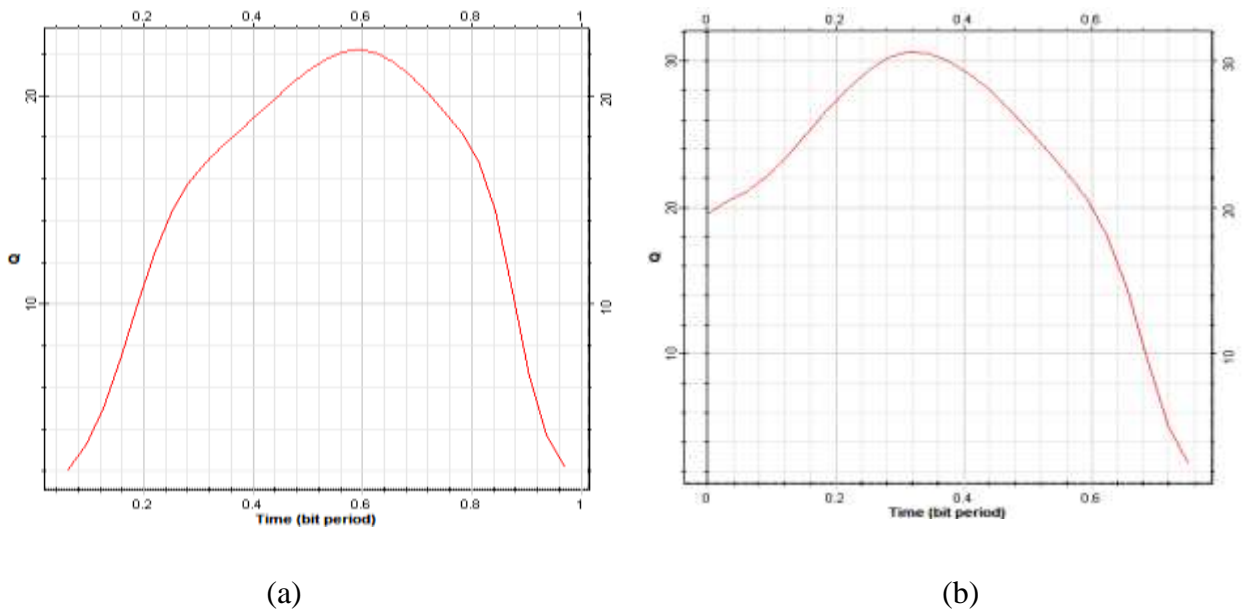

Figure 4.6: Quality factors for (a) CSRZ (b) Duo binary, modulation formats.

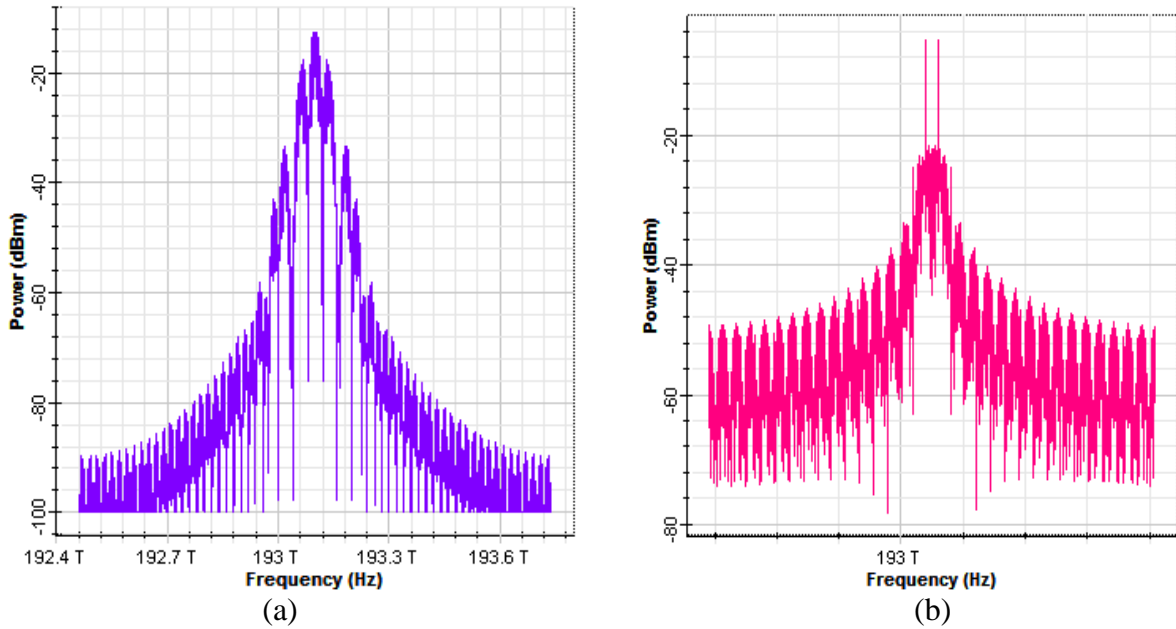

Figure 4.7: Spectrums of (a) Duo binary (b) CSRZ, modulation formats.

The above figure 4.5 shows the eye diagram for amplitude vs. time period for duo binary and CSRZ modulation format used. It is seen that the eye opening is more for CSRZ modulation format when compared duo binary modulation format. Because of narrow spectrum of the duo binary modulation format as can be seen in above figure 4.7, the intersymbol interference largely affects duo binary modulation format. Intersymbol interference reduces the optical signal to noise ratio of the duo binary modulation format. Because of this the optical communication systems having duo binary modulation format has certain disadvantages while using for long distance. The CSRZ format has the maximum eye opening values of eye height 0.003080851 as compared duo binary which is about 0.0021. BER for CSRZ is $1.42e-10^{-9}$ where as for duo binary it is $2.6e-20^{-6}$ for 50 km of length which shows that duo binary performs better as far as BER is considered.

4.4. Conclusion

The performance of CSRZ and duo binary modulation format at 50 Gb/s for the optical communication system is analyzed. It is observed that the CSRZ modulation format has the

edge over duo binary modulation format when considering for dispersion compensation and noise as it is largely affected by intersymbol interference. But when considering BER duo binary is more advantageous. Also as we can see from figure 4.6, quality factor of duo binary is more than CSRZ. Hence it can be concluded that based upon the above results CSRZ and duo binary, both have edge over the other in different scenarios.

CHAPTER 5

CONCLUSION AND FUTURE SCOPE

5.1 Conclusion

The optical rate conversion technique can be used to achieve ultra high speed access to the optical medium on packet by packet basis. Optical delay line structure for rate conversion has been designed and investigated. Rate conversion technique of optical delay line structure enables compression and expansion of very large packets greater than the recirculation loop scheme. Moreover, a scalable packet rate conversion unit allows for simultaneous compression and decompression of large optical packets thereby reducing medium access caused by time out phenomenon. However the proposed scheme is sensitive to gate control signal synchronization. The requirements on the synchronization can be lessened by extension of separation gap between n bit sequences that are separately processed in the M - ODLS. ODLS uses a parallel compression to rapidly tune pulses into different time slots within an OTDM frame. ODLS offers many advantages when compared to the previous tuneable serial techniques in terms of simplicity and scaling towards higher optical baseband bit rate.

Using optical delay line structure we were able to compress data at a bit rate of 1 Tb/s so as to reduce the overall bandwidth. If we take example of 64 byte packet (large enough to hold ATM cell) then it would require 9 compression stages. Also splitting losses can easily be compensated by using a single amplification stage. High bit rate of more than terabit per second range can be used which would be needed due to fast growth of internet traffic demands as well as supercomputer applications.

Further in Chapter 4 we have investigated CSRZ and duo binary advanced modulation formats. The performance of CSRZ and duo binary modulation format at 50 Gb /s for the optical communication system is analyzed. It is observed that the CSRZ modulation format has the edge over duo binary modulation format when we consider dispersion compensation and noise. This was well seen from the eye diagrams of both the modulation formats as eye

height of CSRZ was more as compared to duo binary. Also CSRZ has a broader spectrum and hence less affected by intersymbol interference and noise as compared to duo binary. But when we considered parameters of quality factor and bit error rate, duo binary showed an improved performance as compared to CSRZ.

5.2 Future Scope:

In this dissertation, we have designed optical delay line structure for high bit rate of terabits per second. This work could be extended for advanced dispersion compensation schemes when bits are being transmitted for large distances. Techniques for generation of ultra short pulse can be inculcated using advanced transmitters like travelling wave electro-absorption modulators which are commercially available today. As high bandwidth demands are expected to increase further, OTDM technologies will undoubtedly be coupled with the techniques of wavelength division multiplexing (WDM) networks. By merging these two methods, capacities larger than one terabit per second may be realized. As the combination of OTDM and WDM may form the future of high speed optical communications, the details presented in this thesis are of much use for further development and research.

REFERENCES

- [1] K. C. Kao, G. A. Hockham, "Dielectric-fibre Surface Waveguides for Optical Frequencies," *Proc. I.E.E.*, vol. 113, no. 7, pp. 1151-1158, July, 1966.
- [2] D.W. Smith (ed.), "Optical Network Technology," Chapman Hall, 1995.
- [3] J.P. Ryan, "WDM: North American deployment trends," *IEEE Comm. Mag.*, pp. 40-44, February, 1998.
- [4] P.E. Green, "Fibre Optic Networks," Prentice Hall, 1993.
- [5] ACTS 0058, "Roadmap on Photonic Technologies and Networking," Part C, pp. 15-17, January, 1998.
- [6] M. Nakamura, "Challenges in semiconductor technologies for multi mega-bit network services," *International Solid State Circuit Conference*, paper TA 1.1, 1998.
- [7] K. Runge, R. Yu, S.M. Beccue, P.B. Thomas, P.J. Zampardi, R.L. Pierson, K.C. Wang, "High Speed HBT circuits for up to 40 Gb/sec", *Optical communication Conference (OECC'97)*, *Technical diagram*, paper 8A1-4, pp. 14-15, July, 1997.
- [8] A. Felder, M. Moller, M. Wurzer, T.F. Meister, H. M. Rein, "60 Gbit/sec regenerating demultiplexer in SiGe bipolar technology," *IEEE Electronics Letter*, vol. 33, no. 23, pp. 4-9, 1997.
- [9] M.J. O' Mahony, D. Simeonidou, A. Yu and J. Zhou, "The Design of a European Optical Network," *IEEE Journal of Lightwave Technology*, vol. 13, no. 5, pp. 817-828, 1995.
- [10] C.A. Brackett, "Foreword: Is There an Emerging Consensus on WDM Networking," *IEEE Journal Lightwave Technology*, vol. 14, no. 6, pp. 936-941, 1996.
- [11] P. Green, "Optical Networking update," *IEEE Journal on selected Areas in Comm.*, vol. 14, no. 5, pp. 764-779, 1996.
- [12] G.R. Hill, "A transport network layer based on optical network elements," *IEEE Journal of Lightwave Technology*, vol.1, no. 5/6, pp. 667-679, 1993.
- [13] M. Berger, "Pan European Optical Networking using wavelength division multiplexing', *IEEE Com. Magazine*, pp. 82-86, 1997.
- [14] M. Renaud, F. Maasetti, C. Guillemot, B. Bostica, "Network and System Concepts for optical Packet Switching", *IEEE Communication Magazine*, pp. 96-102, 1997.

- [15] S. Kawanishi, "Single channel 400Gbit/s time-division-multiplexed transmission of 0.98ps pulses over 400km employing dispersion slope compensation," *IEEE Electronics Letter*, vol. 32, no. 10, pp. 916, 1996.
- [16] T. Yamamoto, "Single-channel 640Gbit/s TDM transmission over 100km," *presented at the Eur. Conf. Optical Communication (ECOC'99), Nice, France*, September 26-30, 1999.
- [17] M. Nakazawa, "1.28Tbit/s 70 km OTDM transmission using third- and fourth- order simultaneous dispersion compensation with a phase modulator," *IEEE Electronics Letters*, vol. 36, no. 24, pp. 2027-2029, November, 2000.
- [18] J.P. Turkiewicz, "160Gb/s OTDM networking using deployed fibre," *Journal of Lightwave Technology*, vol. 23, no. 1, pp. 225-235, January, 2005.
- [19] A. H. Gnauck, "1-Tb/s (6x170.6Gb/s) Transmission over 2000-km NZDF Using OTDM and RZ-DPSK Format," *IEEE Photonics Technology Letter*, vol. 15, no. 11, pp. 1618-1620, November, 2003.
- [20] S. Kawanishi, "3 Tbit/s (160Gbit/sx19ch) OTDM/WDM transmission experiment," *Optical Fiber Communication Conf., San Diego, CA, USA*, pp. PD1/1-PD1/3, February, 1999.
- [21] S. Kawanishi, "1.4Tbit/s (200 Gbit/s \times 7 Ch) 50 km optical transmissions Experiments", *IEEE Electronics Letters*, vol. 33, no. 20, pp. 1716-1717, September, 1997.
- [22] A. Suzuki, "10x320Gb/s (3.2Tb/s) DWDM/OTDM transmission in C-band by Semiconductor-based devices," in *Proceedings European Conference on Optical Communication, ECOC'04, Stockholm, Sweden, Paper Th 4.1.7*, September, 2004.
- [23] N. Yoshikane and I. Morita, "160% spectrally-efficient 5.12Tb/s (64x85.4Gb/s RZ-DQPSK) transmission without polarization demultiplexing", in *Proceedings European Conference on Optical Communication, ECOC'04, Stockholm, Sweden, Paper Th4.4.3*, September, 2004.
- [24] Hans-Georg Weber, Reinhold Ludwig, Sebastian Ferber, Carsten Schmidt-Langhorst, Marcel Kroh, Vincent Marembert, Christ of Boerner, and Colja Schubert, "Ultra-high-Speed OTDM-Transmission Technology," *Journal of Lightwave Technology*, vol. 24, no. 12, December, 2006.

- [25] T. Miki, "Optical transport networks," *Proceedings of the IEEE*, vol. 81, no. 11, pp. 1594-1609, November 1993.
- [26] S. Song, Z. Wu, "A broadband integrated services network architecture based on DWDM," *Electrical and Computer Engineering*, vol. 1, pp. 347-352, 2001.
- [27] C. C. Sue, "Wavelength routing with spare reconfiguration for all-optical WDM networks," *Journal of Lightwave Technology*, vol. 23, no. 6, June, 2005.
- [28] K. Bala, "Optical wavelength routing, translation, and packet/cell switched Networks," *Journal of Lightwave Technology*, vol. 4, no. 3, March, 1996.
- [29] X. Chu, B. Li, "Dynamic routing and wavelength assignment in the presence of wavelength conversion for all-optical networks," *IEEE/ACM Transactions on Networking*, vol. 13, no. 3, June, 2005.
- [30] D. J. Blumenthal, "Optical packet switching and associated optical signal processing," *IEEE/LEOS Summer Topic*, pp. TuG2-17-TuG2-18, 2002.
- [31] S. G. Finm, "HLAN- An architecture for optical multi-access network," *Tech. Dig. LEO Summer Top. Meeting*, vol. 45, 1995.
- [32] V. W. S. Chan, "Architectures and technologies for high-speed optical data Networks," *Journal of Lightwave Technology*, vol. 16, no. 12, pp. 2146-2168, December, 1998.
- [33] A. D. Ellis, "Three-node, 40Gbit/s OTDM network experiment using electro-optic Switches," *Electronics Letter*, vol. 30, no. 16, pp. 1333-1334, August, 1994.
- [34] A. D. Ellis, "Ultra-high-speed OTDM networks using semiconductor amplifier-based processing nodes," *Journal of Lightwave Technology*, vol. 13, no. 5, pp. 761-770 May 1995.
- [35] S. A. Hamilton, "40Gb/s all-optical packet synchronization and address comparison for OTDM networks," *IEEE Photonics Technology Letters*, vol. 14, no. 2, pp. 209-211, February 2002.
- [36] R. Smets, "RETINA: High-Capacity Optical Time-Domain Transmission Technologies for Radio Telescopes", *IEEE LEOS newsletter*, pp. 8-11, February 2005.
- [37] J. P. Turkiewicz, "160Gb/s OTDM networking using deployed fibre," *Journal of Lightwave Technology*, vol. 23, no. 1, pp. 225-235, January, 2005.
- [38] H. Sotobayashi, "Hierarchical Hybrid OTDM/WDM Network Based on Fast Optical Signal Processing," *IEEE LEOS Newsletter*, pp. 24-29, October, 2002.

- [39] L. Rau, "High-speed optical time-division-multiplexed/WDM networks and their network elements based on regenerative all-optical ultrafast wavelength converters," *Journal Optical networking*, vol. 3, no. 2, pp. 100-118, February, 2004.
- [40] C. Y. Li, "Performance analysis of realistic optical time division multiplexed wavelength routed networks," *Computer Communication*, pp. 134-138, October, 2003.
- [41] B. Wen, "Routing Wavelength and Time-Slot-Assignment Algorithms for Wavelength-Routed Optical WDM/TDM Networks", *Journal of Lightwave Technology*, vol. 23, no. 9, pp. 2598-2609, September, 2005.
- [42] S. Kawanishi, H. Takara, K. Uchiyama, M. Saruwatari, and T. Kitoh, "Single polarization completely time-division-multiplexed 100Gb/s optical transmission experiment," in *Proc. ECOC*, vol. 3, pp. 53-56, 1993.
- [43] S. Kawanishi, "Ultrahigh-speed optical time-division-multiplexed transmission technology based on optical signal processing," *IEEE Journal of Quantum Electronics*, vol. 34, no. 11, pp. 2064-2079, November, 1998.
- [44] M. Saruwatari, "All-optical signal processing for Tera bit/s optical transmission," *IEEE Journal on Sel. Topics Quantum Electron.*, vol. 6, no. 6, pp. 1363-1374, November/December, 2000.
- [45] R. Ludwig, S. Diez, A. Ehrhardt, L. Kueller, W. Pieper, and H. G. Weber, "A tunable femtosecond modelocked semiconductor laser for applications in OTDM-systems," *IEICE Trans. Electron.*, vol. E81-C, no. 2, pp. 140-145, 1998.
- [46] H. Yokoyama, "Highly reliable mode-locked semiconductor lasers," *IEICE Trans. Electr.*, vol. E85-C, no. 1, pp. 27-36, 2002.
- [47] S. Arahira and Y. Ogawa, "40 GHz actively mode-locked distributed Bragg reflector laser diode module with an impedance-matching circuit for efficient RF signal injection," *Jpn. J. Appl. Phys*, vol. 43, no. 4B, pp. 1960-1964, 2004.
- [48] H. Heidrich, B. Huettl, R. Kaiser, M. Kroh, C. Schubert, and G. Jacumeit, "Optical 40 GHz pulse source module based on a monolithically integrated mode locked DBR laser," *Presented at the SPIE Asia-Pacific Optical Commun. Conf. (APOC), Shanghai, China*, pp. 6020-79, session 12b, 2005.

- [49] K. Tamura, H. A. Haus, and E. P. Ippen, "Self-starting additive pulse mode-locked erbium fibre ring laser," *Electronics Letters*, vol. 28, no. 4, pp. 2226–2228, November, 1992.
- [50] M. Nakazawa, E. Yoshida, and Y. Kimura, "Ultrastable harmonically and regeneratively modelocked polarization-maintaining erbium fibre laser," *Electronics Letters*, vol. 30, no.19, pp. 1603–1604, September 1994.
- [51] S. C. Zeller, L. Krainer, G. J. Spühler, R. Weingarten, K. J. Paschotta, and U. Keller, "Passively mode-locked 40-GHz Er:Yb:glass laser," *Appl. Phys. B, Photophys. Laser Chem.*, vol. 76, no. 7, pp. 787–788, 2003.
- [52] M. D. Pelusi, Y. Matsui, and A. Suzuki, "Femtosecond optical pulse generation from an electro -absorption modulator with repetition rate and wavelength tuning," in *Proc. ECOC, Nice, France*, vol. II, pp. 26–27, 1999.
- [53] M. Nakazawa, E. Yoshida, K. Kubota, and Y. Kimura, "Generation of a 170fs, 10GHz transform-limited pulse train at 1.55 μm using a dispersion-decreasing, erbium-doped active soliton compressor," *Electronics Letters*, vol. 30, no. 24, pp. 2038–2039, November 1994.
- [54] K. R. Tamura and M. Nakazawa, "54-fs, 10 GHz soliton generation from a polarization-maintaining dispersion-flattened dispersion-decreasing fiber compressor," *Opt. Lett.*, vol. 26, no. 11, pp. 762–764, June, 2001.
- [55] W. S. Wong, S. Namiki, M. Margalit, H. A. Haus, and E. P. Ippen, "Self-switching of optical pulses in dispersion-imbalanced nonlinear loop mirrors," *Opt. Lett.*, vol. 22, no. 11, pp. 1150–1152, August, 1997.
- [56] I. Y. Khrushchev, I. D. Phillips, A. D. Ellis, R. J. Manning, D. Nisset, D. G. Moodie, R. V. Penty, and I. H. White, "Dispersion-imbalanced fiber loop mirror for high bit-rate OTDM," in *Proc. ECOC, Nice, France*, vol. II, pp. 24–25, 1999.
- [57] A. H. Gnauck, S. Chandrasekhar, J. Leuthold, and L. Stulz, "Demonstration of 42.7-Gb/s DPSK receiver with 45 Photons/Bit sensitivity," *IEEE Photonics Technology Letter*, vol.15, no. 1, pp. 99–101, January, 2003.
- [58] T. Chikama, S. Watanabe, T. Naito, H. Onaka, T. Kiyonaga, Y. Onoda, H. Miyata, M. Suyama, M. Seino and H. Kuwahara, "Modulation and demodulation techniques in

- optical heterodyne PSK transmission systems,” *Journal of Lightwave Technology*, vol. 8, no. 3, pp. 309–321, March, 1990.
- [59] A. H. Gnauck and P. J. Winzer, “Optical phase-shift-keyed transmission,” *Journal of Lightwave Technology*, vol. 23, no. 1, pp. 115–130, January, 2005.
- [60] T. Ohara, H. Takara, I. Shake, K. Mori, S. Kawanishi, S. Mino, T. Yamada, M. Ishii, T. Kitoh, T. Kitagawa, K. R. Parameswaran, and M. M. Fejer, “160 Gb/s optical-time-division multiplexing with PPLN hybrid integrated planar lightwave circuit,” *IEEE Photon. Technol. Lett.*, vol. 15, no. 2, pp. 302–304, February, 2003.
- [61] T. Ohara, H. Takara, I. Shake, K. Mori, K. Sato, S. Kawanishi, S. Mino, T. Yamada, M. Ishii, I. Ogawa, T. Kitoh, K. Magari, M. Okamoto, R. V. Roussev, J. R. Kurz, K. R. Parameswaran, and M. M. Fejer, “160-Gb/s OTDM transmission using integrated all-optical MUX/DEMUX with allchannel modulation and demultiplexing,” *IEEE Photonics Technology Letter*, vol. 16, no. 2, pp. 650–652, February, 2004.
- [62] H. Murai, K. Masatoshi, H. Tsuji, and K. Fujii, “Single channel 160 Gb/s carrier-suppressed RZ transmission over 640 km with EA modulator based OTDM module,” presented at the *Eur. Conf. Optical Commun. (ECOC), Rimini, Italy*, Paper no.3.6.4, 2003.
- [63] S. Randel, B. Konrad, A. Hodzic, and K. Petermann, “Influence of bitwise phase changes on the performance of 160 Gb/s transmission systems,” presented at the *Eur. Conf. Optical Commun. (ECOC), Copenhagen, Denmark*, Paper P3.31, vol. 3, 2002.
- [64] Tucker, Einstein, Korotky, Buhl, Veselka, Raybon, Kasper, Alferness, “16Gbit/s fibre transmission experiment using optical time-division multiplexing,” *I.E.T Electronics letters*, vol. 23, issue 24, pp. 1270-1271, November, 1987.
- [65] Rodney S. Tucker, Gadi Eisenstein, and Steven K. Korotky, “Optical Time-Division Multiplexing For Very High Bit-Rate Transmission,” *Journal of Lightwave technology*, vol.6, no. 11, pp. 1737-1749, November, 1988.
- [66] Takayuki Kurosu, Ken Tanizawa, Shu Namiki, Ryoichi Akimoto, Haruhiko, Kuwatsuka, Toshifumi Hasama, Hiroshi Ishikawa, Tsuyoshi Nakatogawa, Kimiyuki, Oyamada, Y. Tanaka, Satoshi Ide, H. Onaka, and T. Asami, “Dynamic Optical Path Switching in 172 Gb/s OTDM Transmissions of Ultra-High Definition Video Signals Using Fast Channel-

- Identifiable Clock Recovery and Integratable Devices”, *Journal of Lightwave Technology*, vol. 31, no. 4, pp. 594-601, February 15, 2013.
- [67] Deming Kong, Hui Wang, Yan Li, Jizhao Zang, Siyuan Zhou, Xixue Jia, Jian Wu and Jintong Lin, “Ultra-low Timing-Jitter 40GHz Clock Recovery Using EAM-MZMM Double-Loop and Its Application in a 640Gbit/s OTDM System”, *IEEE Optical Communications (ECOC), 2012 38th European Conference and Exhibition*, pp. 1-3, September, 2012.
- [68] Shangjian Zhang, Rongguo Lu, Yali Zhang, Shuang Liu, Yong Liu, “Self-Clocking based on in-band Pilot for Ultra-high bit rates OTDM system”, *IEEE Optical Fiber Communication Conference and Exposition (OFC/NFOEC), 2012 and the National Fiber Optic Engineers Conference*, pp. 1-3, March, 2012.
- [69] Arash Yazdani, Sebastia Sallent, David Rincon, Mohammad Noshad, “Study of the Optimum Pulse-Width of Clock Signal in Optical AND Gates for Application in Ultra-Fast OTDM Networks,” *Transparent Optical Networks (ICTON), 2012 14th International Conference*, pp. 1-2, July 2012.
- [70] T. Kurosu, K. Tanizawa, S. Namiki, T. Nakatogawa, and K. Oyamada, "344-Gb/s dual-polarization OTDM transmission of uncompressed ultra-high definition video signal," *Opto-Electronics and Communications Conference (OECC), 2012 17th*, vol. no. 4, pp. 461-462, July 2, 2012.
- [71] Chi Zhang, Xie Wang, Xing Xu, P. C. Chui, and Kenneth K. Y. Wong, “Simultaneous Demultiplexing of OTDM Channels Based on Swept-Pump Fiber-Optical Parametric Amplifier,” *IEEE Optical Fiber Communication Conference and Exposition (OFC/NFOEC) and the National Fiber Optic Engineers Conference*, pp. 1-3, March, 2012.
- [72] E. Palushani, T. Richter, R. Ludwig, C. Schubert, H. C. H. Mulvad, A. T. Clausen and L. K. Oxenløwe, “OTDM-to-WDM Conversion of Complex Modulation Formats by Time Domain Optical Fourier Transformation,” *IEEE Optical Fiber Communication Conference and Exposition (OFC/NFOEC), 2012 and the National Fiber Optic Engineers Conference* pp. 1-3, March, 2012.

- [73] Masato Otsuki, Renjo Takama and Hiroyuki Toda, "A Phase Stabilized Quadruple OTDM Multiplier for RZ/CS-RZ Optical Clock with an Optical Bandpass Filter," *IEEE Communications and Photonics Conference (ACP), 2012 Asia*, pp.1-3, November, 2012.
- [74] Gordon K. P. Lei and Chester Shu, "Reconfigurable OTDM Demultiplexing Using Time and Wavelength-Interleaved Pulses in an Optical Parametric Amplifier," *IEEE Photonic Technology Letters*, vol. 23, no. 16, pp. 1127-1129, August 15, 2011.
- [75] H. Hu, H.C. Hansen Mulvad, C. Peucheret, M. Galili, A.T. Clausen, P. Jeppesen and L.K. Oxenløwe, "10 GHz Pulse Source for 640 Gbit/s OTDM based on LiNbO₃ Modulators and Self-Phase Modulation," *IEEE Optical Communication (ECOC), 2011 37th European Conference and Exhibition*, pp.1-3, September, 2011.
- [76] Johannes Karl Fischer, Lutz Molle, Markus Nölle, Carsten Schmidt-Langhorst, Jonas Hilt, Reinhold Ludwig, David W. Peckham and Colja Schubert, "8×448-Gb/s WDM Transmission of 56-GBd PDM 16-QAM OTDM Signals Over 250-km Ultra large Effective Area Fiber," *IEEE Photonics Technology Letters*, vol. 23, no. 4, pp. 239-241, February 15, 2011.
- [77] A. Bogoni, Wu Xiaoxia, S.R. Nuccio, Wang Jian, Z. Bakhtiari, and A.E. Willner, "Photonic 640-Gb/s Reconfigurable OTDM Add-Drop Multiplexer Based on Pump Depletion in a Single PPLN Waveguide," *IEEE Journal of Selected Topics in Quantum Electronics*, vol.18, no. 2, pp. 709-716, March-April, 2012.
- [78] Jia Nan, Tang Jun Li, Kang Ping Zhong, Jian Sun, Mu Guang Wang, and Jing Li, "Simultaneous Clock Enhancing and Demultiplexing for 160-Gb/s OTDM Signal Using Two Bidirectionally Operated Electroabsorption Modulators," *IEEE Photonics Technology Letter*, vol. 23, no. 21, pp.1615-1617, November 1, 2011.
- [79] H. C H Mulvad, H. Hu, M. Galili, H. Ji, E. Palushani, A.T. Clausen, L.K. Oxenlowe, and P. Jeppesen, "DWDM-to-OTDM conversion by time-domain optical Fourier transformation," *Optical Communication (ECOC), 2011 37th European Conference and Exhibition on*, vol. 6, no.6, pp. 1-3, 18-22, September, 2011.
- [80] H. Hu, J.L. Areal, H.C H Mulvad, M. Galili, K. Dalgaard, E. Palushani, A.T Clausen, M.S. Berger, P. Jeppesen and L.K. Oxenlowe, "Synchronization, retiming and OTDM of an synchronous 10 Gigabit Ethernet NRZ packet using a time lens for Terabit

Ethernet,"*Optical Communication (ECOC), 2011 37th European Conference and Exhibition on* , vol.6, no.8, pp.1-3, 18-22, September, 2011.

[81] M.V. Drummond, A. L. J. Teixeira, P.P. Monteiro, R.N. Nogueira, "Routable OTDM to WDM converter enabled by a programmable optical processor," *Optical Communication (ECOC), 2011 37th European Conference and Exhibition on*, vol. 7, no. 8, pp. 1-3,18-22, September, 2011.

[82] Sanmukh Kaur , R.S. Kaler, "Performance of RZ and NRZ modulation Format in 40–160 Gb/s OTDM system demultiplexing", *International Journal for Light and Electron Optics*,June ,2013.