

**REAL POWER CONTROL OF STORAGE FREE HYBRID MICROGRID**

*Dissertation submitted in partial fulfillment of the requirement for the award*

*of the degree*

*of*

**Master of Engineering**

*in*

**POWER SYSTEMS**

*Submitted By*

Manish Kumar Yadav

(Regd. No. 801542012)

*Under the supervision of*

Dr. Prasenjit Basak

Assistant Professor, EIED



**ELECTRICAL AND INSTRUMENTATION ENGINEERING DEPARTMENT**

**THAPAR UNIVERSITY**

**PATIALA (PUNJAB)-147004**

**JUNE, 2017**

## CERTIFICATE

I hereby certify that the work which is being present in the dissertation entitled “**Real Power Control of Storage Free Hybrid Microgrid**” in partial fulfillment of the requirement for the award of degree of Master of Engineering in Power Systems submitted in the Electrical and Instrumentation Engineering Department of Thapar University, Patiala is an authentic record of my own work carried out under the guidance of **Dr. Prasenjit Basak**, Assistant Professor, EIED.

The matter presented in the dissertation has not been submitted for the award of any other degree of this or any other university.

**Place:** Patiala

**Date:** 22-06-17

It is certify that the above statement made by the student is correct to the best of my knowledge & belief.

**Date:** 22-06-17



(**Manish Kumar Yadav**)

(Regd. No. 801542012)



(**Dr. Prasenjit Basak**)

Electrical & Instrumentation Engineering Department

Thapar University, Patiala

## Acknowledgement

---

I would like to thank the Thapar University for giving me the opportunity to use their resources & work in an inspiring atmosphere.

First and foremost, I take this opportunity to express my deepest sense of gratitude to my guide **Dr. Prasenjit Basak**, Assistant Professor, Thapar University, Patiala for his able guidance during my dissertation work. This dissertation would not have been possible without his help and the valuable time that he has given me amidst of his busy schedule.

I would like to express my deepest sense of gratitude towards **Dr. Ravinder Agarwal**, Professor and Head, **Ms. Manbir Kaur**, Associate Professor (P.G. Coordinator), EIED, Thapar University, Patiala who has been a constant source of inspiration for me throughout this dissertation.

I would also like to extend my gratitude to my parents and friends of this department who have always encouraged and supported me in doing my work.

Last but not the least I would like to thank all the staff members of the department of Electrical and Instrumentation Engineering who have been very cooperative with me.

Manish Kumar Yadav

(801542012)

## Table of Contents

---

Acknowledgement .....	i
Table of Contents .....	ii
List of Figures .....	vii
List of Tables .....	vii
List of Abbreviations .....	viii
Abstract .....	x
1. Introduction.....	1
1.1 OVERVIEW.....	1
1.2 LITERATURE SURVEY .....	3
1.3 GAP IN RESEARCH.....	8
1.4 OBJECTIVE OF DISSERTATION.....	9
1.5 ORGANIZATION OF THE DISSERTATION WORK.....	9
2. Neuro- PI controller for efficient energy management of storage free Diesel-SPV based hybrid microgrid.....	11
2.1 SYSTEM DESCRIPTION .....	11
2.1.1 Relation between Power deviation and Frequency.....	12
2.1.2 Diesel Generator module .....	13
2.1.3 SPV Generator module .....	13
2.1.4 Dynamic modulation of MPPT current.....	15
2.2 FUNCTION OF PROPOSED CONTROLLER.....	16
2.2.1 Back Propagation Algorithm .....	16
2.2.2 Description of proposed controller .....	18
2.3 DISCUSSION ON RESULTS .....	20

2.3.1	Scenario-1 .....	20
2.3.2	Scenario-2 .....	21
2.4	CONCLUSIONS .....	22
3.	Adaptive neuro fuzzy controller for real power control of storage free hybrid microgrid .....	23
3.1	SYSTEM DESCRIPTION .....	23
3.1.1	Relation between real power & frequency deviance .....	24
3.1.2	SPV generator module .....	25
3.1.3	Speed governing module of Diesel Generator .....	27
3.1.4	MPPT current flow control .....	28
3.2	FUNCTION OF PROPOSED CONTROLLER.....	28
3.2.1	Adaptive Neuro-Fuzzy Inference System.....	28
3.2.2	Buck converter .....	30
3.2.3	Testing and model validation.....	30
3.3	DESCRIPTION OF PROPOSED CONTROLLER.....	31
3.3.1	Algorithm of proposed controller .....	31
3.3.2	Architecture of proposed controller .....	33
3.4	DISCUSSION ON RESULTS .....	34
3.4.1	Scenario-1 .....	34
3.4.2	Scenario-2 .....	35
3.4.3	Scenario-3 .....	36
3.4.4	Scenario-4 .....	38
3.4.5	Scenario-5 .....	39
3.5	CONCLUSION .....	41
4.	Conclusion and Future scope of work.....	42

4.1	CONCLUSIONS .....	42
4.2	FUTURE SCOPE OF WORK.....	42
	List of Publications .....	43
	References.....	44
	Appendix.....	48

## List of Figures

---

Fig. 1 Proposed SPV-DG Hybrid Microgrid without Storage system.....	12
Fig. 2. Single Diode based Solar Cell model .....	14
Fig. 3. P-V characteristics of Solar Panel .....	14
Fig. 4. Modulation of MPPT current. ....	15
Fig. 5. Control flow chart showing function of controller.....	17
Fig. 6. Flow of data in back propagation algorithm.....	18
Fig. 7. Block diagram presentation of proposed controller. ....	19
Fig. 8. Typical circuit diagram of Buck Converter with Neuro-PI controller. ....	20
Fig. 9. Virtual Inertia effect in SPV generator.....	21
Fig. 10. Flow of power in the proposed system.....	22
Fig. 11. System Description.....	24
Fig. 12. SPV panel as controlled source. ....	25
Fig. 13. Modelling of speed governor of Diesel Engine.....	27
Fig. 14. Diesel Engine based Synchronous Generator.....	28
Fig. 15. ANFIS flow chart .....	29
Fig. 16. Buck converter.....	30
Fig. 17. Structure of ANFIS.....	31
Fig. 18. Flow chart of proposed system.....	32
Fig. 19. Architecture of proposed controller.....	33
Fig. 20. Frequency response at CL terminal fulfilled by SPV generator.....	34
Fig. 21. Real power of CL load fulfilled by SPV generator. ....	35
Fig. 22. Frequency response of the system. ....	36
Fig. 23. Real power to CL and NCL fulfilled by SPV.....	36
Fig. 24. frequency response of the system at CL terminal.....	37
Fig. 25. Real power demand of CL fulfilled by SPV generator & DE.....	38
Fig. 26. Frequency response at CL fulfilled by DE.....	39
Fig. 27. Real power response of CL fulfilled by DE. ....	39
Fig. 28. Frequency response at variable CL terminal. ....	40

Fig. 29. Real power of variable CL fulfilled by DE. .... 40

## **List of Tables**

---

Table 2.1. Specification of components used in Simulink model.....	12
Table 3.1. Specification of components used for modelling of proposed system .....	24

## List of Abbreviations

---

AEMS	Adaptive Energy Management Scheme
ANFI	Adaptive Neuro fuzzy Inference
ANFIS	Adaptive Neuro Fuzzy Inference System
ANN	Artificial Neural Network
BP	Back Propagation
BPA	Back Propagation Algorithm
CLTV	CL terminal voltage
CCP	Common coupling point
CL	Critical Load
DE	Diesel engine
DE	Diesel Engine
DERs	Distributed Energy Resources
DG	Distribution generation
FC	Fuel cell
FIS	Fuzzy inference system
HL	Hardware in loop
HESS	Hybrid Energy Storage System
IADC	Interlinking AC-DC converter
MPP	Maximum power point
NCL	Non Critical load
NMPC	Non-linear Model Predictive Control
PQDC	P/Q-droop control
PLL	Phased Locked Loop
PV	Photovoltaic
RTDS	Real-time digital simulator
RCLTV	Reference CL terminal voltage
SPV	Solar photovoltaic

SOC	State of charge
SG	Synchronous generator
VFDC	V/F-droop control
VSC	Voltage source converter
WG	Wind generator

## Abstract

---

A smart microgrid should be well equipped with an efficient power flow control mechanism so that the consumer may use renewable energy sources in more economical way to reduce the use of fossil fuel based conventional sources. Control of power flow and frequency in a hybrid microgrid in islanded mode is different compared to the same while operating in grid-connected mode. The proposed scheme presented in this thesis is an effort to show the spinning reserve effect of Solar Photovoltaic (SPV) generator in storage free Diesel-SPV based hybrid microgrid. It is proposed that maximum utilization of reserve power of SPV generator in to dc load is possible by using Neural Network Back Propagation Algorithm (BPA). This is an algorithm for coordinated control strategy of Diesel Engine (DE) and SPV generator.

This thesis is also an effort to suggest an Adaptive Neuro fuzzy Inference (ANFI) Logic based control system having variable reference input which makes it able to model uncertain and non-linear conditions. To show the virtual inertia effect of SPV generator an ANFI based controller is proposed which can coordinate the control scheme of SPV and DE based hybrid microgrid having both AC and DC loads. The above two proposed control strategies facilitate efficient energy management which controls the individual power flow of SPV generator and DE to fulfill the real power demand by Critical Load (CL). The operation and performance of the proposed controller are verified through simulation MATLAB package.

# Chapter 1

## Introduction

---

### 1.1 OVERVIEW

In the last few years, in power system a new tradition is increased to connect the distribution generation (DG) with grid and it is estimated that this advancement may continue and even grow in future. Amendment in electric utility industry, environmental anxieties and fast growing technological enlargements of DG system is reflected as the main reason of this propagation. However, as there is increment in DG facilities their effect on the grid operation cannot be considered as insignificant any more. The concept of microgrid is fascinating solution to develop the integration of DG system with grid. A microgrid may be treated as a group of generator and load synchronized with grid at a single point that convoyed with diverse control level may be seen as a controlled load or generator by grid. Microgrid can work both in grid-tied and in islanded operating mode.

In order to succeed stable and tolerable operation of a microgrid, frequency control is essential about its rated value. For the frequency fluctuation, balance of active power is essential followed by a disturbance. Generally, rotating machine such as synchronous generator is not available in microgrid system working in islanded mode. This type of generator has high kinetic energy in form of inertia, due to absence of this, frequency expedition in microgrid followed by disturbance will be more. It leads the microgrid system being unstable except other electrical source (non-rotating) help to balance the load power demand.

A smart microgrid in islanded mode it may contain solar photovoltaic (SPV) generator, fuel cell (FC), wind generator (WG), diesel engine (DE), resistive and inductive loads. Being a rotating machine, DG will response to inertia effect, primary and secondary frequency will be controlled by its speed governor. Likewise, the consumed power of an induction motor depend on the frequency, henceforth it contribute to control the frequency of microgrid. However, the SPV cannot control the frequency as it is interfaced with inverter unless explicitly controlled for it. On the other hand, it is a challenging job to provide real power to system from SPV generation. In this type of situation, for real power supply there are many suggested system by researchers who

proposed storage system (normally battery bank of proper capacity) and without storage system. Due to the different type of power generator, it would affect the power quality supplied by the microgrid and it may cause various control problems to be allocated with. Controlling of power quality is essential to recover the frequency fluctuation followed by an accidental power variation at generating and load side.

Hybrid AC/DC microgrid is intended for the enhanced interconnection of different DGs with utility grid and developing the projecting structures of both AC and DC microgrid. Interconnection of these microgrid require an interlinking AC to DC converter (IADC) with an appropriate power managing and controlling approach. In islanded operating mode of the hybrid AC/DC microgrid, the IADC is anticipated to take responsibility to supply for one microgrid and simultaneously act as a load for other microgrid & the power balancing of system must be capable to fulfill the demand power b/w existing ac and dc source in hybrid microgrid. It consider the controlling and management of power flow issues of total system. This type of architecture of hybrid microgrid permits different type of ac or dc load and sources to be adaptably located in order to have low requirement of power conversion stage and hence system to be efficient and economic.

The synchronization of DGs to the power grid through power electronic devices make it more concerned about appropriate load sharing among different DG and power grid. Generally, microgrid can be observed as a cluster of DGs connected with main utility, based on voltage source converter (VSC) interfacing. Regarding the interfacing of a microgrid with power grid, it is significant to attain a suitable load sharing by DGs. To stabilize the low inertial hybrid microgrid SPV generator is used as controlled source, very frequently as in buck and boost mode. It does not explore that what will happen with the de-rated part of energy generated by SPV generator.

In this thesis, a novel coordinated controlling strategy is projected to control the frequency and real power in islanded operating mode of a hybrid microgrid based on SPV generator and DG without any storage system having ac and dc loads. The output of the SPV generator is kept at its MPPT point always, the load is categorized in two part CL (AC load) and NCL (DC load). Instantaneous power flow is controlled for NCL followed by fulfilling the CL by SPV generator through a Neural Network BPA based controller. The energy is managed for CL based on the strategy of SPV first philosophy and then by DG. In case of low power demand less than SPV

generation the NCL will be energized by the extra energy of SPV.

## 1.2 LITERATURE SURVEY

Through relevant literature survey it is found that there are different type of control philosophy with different type of system to manage the energy and control the frequency and real power.

A medium voltage islanded microgrid of Dongao Island is presented, integrated with DGs based on renewable energy, storage system and different load. In islanded microgrid to support the frequency, there is much composition for controlling and management. So to regulate the frequency-stability in multiple time scaled, a hierarchical controlling approach is offered. The offered control architecture distributes the system frequency in three zone: (A) Stable Zone, (B) Precautionary Zone and (C) Emergency Zone. So, dynamic stability which cope up with disturbance in short time is executed by microgrid central controller within zone B and zone C. Temporarily, steady state stability regulator to solve the peak and valley problem of load and DG in long time scale is implemented by energy managing system within zone A. Additionally, based on the advanced comprehensive small signal state space model, sensitivity investigation of the eigenvalue is accompanied to disclose the dynamic stability range of the medium voltage microgrid, and to recognize the suitable range of the controlling parameter of zone B [1].

An adaptable coefficient joined pretend inertia & primary-frequency controlling policy for Doubly-Fed-Induction-machine coordinated with DE to participate in wind, SPV, DE based microgrid. The specific frequency response is investigated under diverse wind speed with consistent inertia control parameter [2].

Here a smooth switching droop control is obtained based on which it offered a flexible power controlling of each unit, may be attained by seamless mode change [3].

A unified Adaptive Energy Management Scheme (AEMS) is projected for Hybrid Energy Storage System (HESS) interfaced with renewable energy sources under grid tied or islanded operating condition. A Phased Locked Loop (PLL) is used based on second harmonic for an appropriate synchronization of the microgrid under any possible conditions. To operate and manage the microgrid system under both modes novel power management algorithm is accomplished. A quantifiable analysis on the HESS outcome is provided to explore the usefulness of the proposed methodology. Load restriction and off maximum power point tracking features is

also provided in the projected scheme. This approach present unified transfer between the various modes of the system and have some additional features such as enhancement of power quality and effective power sharing among various sources. [4]

Microgrid can be operated in both grid tied and islanded condition. In islanded condition controlling of microgrid is much complex because of its poor inertia. Control of virtual impedance may be a clarification to decouple the real and apparent power allocation among energy storage system. Though, the bandwidth is compact, it require low pass filter with compact bandwidth to compute average real and apparent power. It consists a novel controlling method for energy storage system by using V/F Droop Control (VFDC) and P/Q Droop Control (PQDC). It can allocate the real and apparent power accurately and it prevent the interference of uncertainty in line parameter and stability of system is improved [5].

Without any communication system and central controller, all the power generator operate in a condition such that the SPV unit trace and supply maximum power to make the system energy efficient, the battery unit control charging and discharging of system based on SOC and load demand condition to assurance of secure SOC, FC-eletrolyser units work as the axillary source of system, which supply the balance energy and absorb the redundant energy of system for healthy and stable operating condition. This scheme do not only facilitate the plug & play ability for the DG, but also make it conceivable to sustain independent energy optimized operation [6].

In the projected strategy, parameter of SPV generator is being secure in co-ordination with other generator by using Neuro-Fuzzy controller, for frequency deviation in transient time only and for steady-state frequency deviation, dependent on load power, hence it eliminates the enormous storage requirement. Option for controlling of load response is also done along with the controlling of generation. For precise and rapid tracing of MPPT point and its accompanying reserve power of SPV generators. [7]

A controller is design which is skilled with  $P_{mpp}$  v/s  $V_{mpp}$  characteristics for different temperature and fuzzy logic is being used to apply variable reference voltage exposed to value limited by ANN. This learning pronounces that a data analysis based system can be exploited to keep the power system stable in emergency condition [8].

SPV systems are currently permitted to inject into utility all the generated power. Though, in the near future, utility is estimated to impose surplus regulation and restriction on the power being inserted by SPV system because of their probable hostile impact. Leading objective of this paper is to explore some method that may be used to diminish the fluctuation in the power generated SPV system. The paper efforts on three method: 1) The use of energy storage system, 2) The use of dump load; and 3) limitation of the generated power by using MPPT on SPV system below the Maximum Power Point[9].

A methodology for designing of an optimal analytical controlling scheme is used for islanded microgrid. Controller manage the energy of batteries and makes an integrated load shedding approach for balancing of demand and generated power of the system, and to limit the voltage magnitude stable of the system. The algorithm of Nonlinear Model Predictive Control (NMPC) is applied for treating a set of data collected from the State of Charge (SOC) of batteries, the Distributed Energy Resources (DERs), and the estimated load. The NMPC identify forthcoming of disturbance in real power and take decision to shade the load for non-critical load. The control policy is verified in a distribution system operated at medium voltage with DERs. The difference between generated power of DER and load power is sustained, however the voltage is restricted within the deviation range of 5%, mentioned in the standard ANSI C84.1-1989 [10].

To flow the desired active and apparent power between grid and microgrid back to back converter is being used. A planning among DGs of microgrid is suggested to attain sharing of load in both grid tied & isolated mode. A back to back converter is also used for the frequency insolation b/w main grid & microgrid. It results that the deviation in voltage or frequency on grid side has no influence [11].

There is evaluation of feasibility of controlling policies to be accepted for the operation of a microgrid when it is in islanded condition. Generally, the microgrid operate synchronized with the medium voltage system. Though, there is planned or forced isolation, in such condition, the microgrid should have the capability to function stably. A calculation of the necessity of storage system and load shedding policies is comprised in [12].

Small signal stability studied result of an independent Hybrid Renewable Energy Power Generation and energy storage system using time-domain simulation is presented in this paper. An

Aqua Electrolyzer absorb a part of generated energy from SPV or WT to generate offered hydrogen for FC. A time-domain approach based on three mathematical models for three studied cases under various operating points and disturbance conditions is performed. [13]

To reduce the number of sensor for synchronization of utility and hybrid microgrid a superior power managing scheme is proposed. In this system, an improved DC link voltage regulation is attained and the application of super capacitor diminishes the current stress on battery [14].

There is representation of active and reactive power management policies of DGs having electronic interfacing unit in the environment of various DG based microgrid. DG control the power flow managing policies based on nearby measured signal without any communication system. Based on apparent power control scheme, different type of power managing policies are recognized and explored on the basis of 1) Voltage-Droop characteristics, 2) Voltage-Regulation and 3) Apparent power compensation at load end. Eigen structure of microgrid (advanced model) is used to 1) inspect the microgrid vigorous performance, 2) choose controlling parameter of DG unit & 3) incorporative power managing policies of DG controller. This model is also used to examine efficiency of the proposal, if there is changes in parameter and operating condition and to enhance the outcome of microgrid system [15].

This paper explains power modulation of a SPV generator to control frequency regulation. System consists a small capacitor which dump out the rapid fluctuation of SPV generation, and allow the generator to change the output at limited rate. The capacitor voltage is kept at a fixed value to sustain acceptable energy storage. Output of generator is modulated in proportional to the frequency deviance. The response to step and periodic change of the frequency is inspected [16].

A method is used to improve & trial the control algorithm and operating arrangements, is projected as hardware in loop (HL) for a microgrid. For real-time simulation of the microgrid HL system is composed of a real-time digital simulator (RTDS), a model of microgrid managing system is under trial, a communication simulator is used to interface MMS and RTDS. The model of MMS is considered to operate micro source and to control the flow of power at coupling point in the grid-tied condition [17].

An improved hierarchical control organization with multiple-current-loop restraining systems for voltage disturbance and harmonic recompense in an islanded AC microgrid is planned for

unsatisfactory power sharing problem. The projected controlled system of the microgrid contains the positive sequence active and apparent power controller, current and voltage controller, the secondary control of voltage magnitude and reestablishment of frequency, and the supplementary control to attain a qualitative voltage at common coupling point. By using offered disturbed and harmonic compensator, the supplementary control, and a virtual-positive and negative-sequence-impedance loop at fundamental frequency and simulated variable harmonic-impedance-loop at harmonics frequency, a precise power division is attained. Furthermore, the small bandwidth communication method is accepted to refer the compensating command of subordinate control from Microgrid Central Controller to local controller of DGs [18].

The fundamental concept of central power management system and decentralized vigorous control scheme for independent operating condition of microgrid which include multiple DERs unit. DERs unit are categorized into voltage-controlled and power-controlled unit. Frequency of DER units is calculated by inbuilt oscillator, all oscillator are coordinated at a GPS based reference time-signal. Power Management system specify power & voltage fixed point for local controller of individual DER unit. Every control agent guaranteed for fast tracing, null steady-state-error and vigorous outcome in-spite-of uncertainty of the microgrid parameter [19].

A control scheme is proposed for a three phase isolated SPV-Diesel based microgrid any energy storing element. The system objectives to: track maximum power from SPV, control the load terminal voltage, balanced load is fulfilled by DE, and to govern the DE speed. These tasks are attained by monitoring the PWM inverter interfaced with SPV array and by modifying fuzzy logic based controller for the DE. Two different process schemes are projected to provide quality power under all loading scenario [20]

Power output of SPV varies according to the climate condition. Instable SPV power cause frequency deviation in the power utility when the perception is high. Generally, an Energy Storage System is used for the smoothness of the SPV power output fluctuation and then the levelled power is provided to the grid. Here a fuzzy logic based frequency controlling system is offered for the SPV generators in a SPV–Diesel based hybrid microgrid without levelling of SPV power fluctuation. The power output of a SPV generator control condition of power utility and make best use of energy efficient. Here, fuzzy logic is used to control the SPV output power. Average

insolation, instantaneous insolation, and frequency deviance is used as input to fuzzy logic. The projected technique is compared with a MPPT control based technique [21].

For use in real-time, a round-trip efficient storage system and operational cost concept was expressed to take dispatch conclusions to have enhanced performance of overall system. In this paper the theory of part I is employed with a decentralized Multi Agent System for power management of a hybrid microgrid in grid-tied as well as islanded mode [22].

A decentralized controlling scheme for a microgrid is offered, along with a real time simulation environment and decision making capable based on agent system [23].

The secondary frequency control loop is established by using  $H_\infty$  and  $\mu$ -synthesis vigorous control method. In projected control structure some micro sources like DE, micro turbine, and FC are expected to be accountable for fulfilling the load demand in microgrid. The synthesized  $H_\infty$  and  $\mu$ -controller is inspected on a platform of microgrid [24].

A framework is presented for the coordination DERs and response of voltage and frequency by load to support the islanded microgrid. The projected method is basically depend on data mining from active and apparent power sensitivity at different bus to minimizing the voltage and frequency deviances in islanded condition of microgrid. For this, a power flow route is assumed in which the frequency deviance seems as an extra state variable. It helps to compute the mandatory set points of DERs as well as the amount of load demand reduced by the controlled load to achieve the goal. The loads are categorized on the basis of the degree of controllability. To minimize the manipulated load, the most effective buses are selected based on their associated sensitivity values. In the grid-tied operating condition, the total operation cost is minimized, while the microgrid bus voltages are maintained within the pre-specified acceptable range. Whole procedure is framed as a multi-objective problem resolved by the Particle Swarm Optimization. The controlling process contains a number of command for which a safe communication structure as incident command system is used [25].

For active and apparent power management three different methods are suggested having some features as: it is useful for both current controlled and voltage controlled VSC. Idea of hybrid polar vector control is established, due to behavior of controller as synchronous machine it have good results of controlling scheme [26].

### **1.3 GAP IN RESEARCH**

The detailed literature survey on implementation of various controller towards controlling of active power of hybrid microgrid is done. It do not elaborate that apart from de-rating of SPV generator we should use the extra amount of energy to other load to increase the efficiency of system if the power generated by SPV is more than total demand power.

In this dissertation, a novel coordinated controlling scheme is suggested for a storage free, islanded hybrid microgrid based on SPV and DE generator connected with CL and NCL load both. Operating condition of SPV generator will be at MPP condition for maximum time, the load is categorized in two part CL (AC load) and NCL (DC load). Power flow is being instantaneously controlled to NCL followed by the CL demand fulfilment by SPV generated power through a neuro-fuzzy controlling scheme. Energy management philosophy is to use of DE power followed by SPV power to fulfill the CL demand power. In low CL demand scenario balanced amount of SPV power is being supplied to the NCLs.

### **1.4 OBJECTIVE OF DISSERTATION**

The aim of this dissertation is to study the dynamic performance of SPV generator in islanded operating mode of hybrid microgrid based on Diesel and SPV generation by modelling and simulation using MATLAB package. The variable parameters like solar irradiance, cell temperature, load demand & real power of critical load are considered in the present research work.

The objectives of the dissertation are:

- a) Assessment of technologies being used to manage the real power demand to be implemented in the emerging hybrid microgrid system.
- b) To propose a model based on Neuro-PI controller to control the flow of real power in islanded microgrid system.
- c) To propose an adaptive Neuro-Fuzzy controller for real power control of storage free islanded hybrid microgrid.

### **1.5 ORGANIZATION OF THE DISSERTATION WORK**

The dissertation is organized in four chapters.

The overview of Hybrid microgrid and its real power controlling methods, a thorough literature survey of the present work, gap in research for the present work, objective of dissertation as presented in the dissertation including organization of the dissertation work are presented in the current **Chapter 1**. The **Chapter 2** proposes a Neuro–PI Controller for efficient energy management of storage free DIESEL-SPV based hybrid microgrid. In **Chapter 3**, an Adaptive Neuro-Fuzzy controller has been proposed for real power control of hybrid microgrid. **Chapter 4** presents the conclusion and future scope of this work.

## Chapter 2

### **Neuro- PI controller for efficient energy management of storage free Diesel-SPV based hybrid microgrid**

---

A smart microgrid should be well equipped with an efficient power flow control mechanism so that the consumer may use renewable energy sources in more economical way to reduce the use of fossil fuel based conventional sources. Control of power flow and frequency in a hybrid microgrid in islanded mode is different compared to the same while operating in grid-connected mode. The proposed philosophy presented in this chapter is an effort to show the spinning reserve effect of Solar Photovoltaic (SPV) generator in storage free Diesel-SPV based hybrid microgrid. It is proposed that maximum utilization of reserve power of SPV generator in to dc load is possible by using Neural Network Back Propagation Algorithm (BPA). This chapter proposed an algorithm for the coordinated control strategy of Diesel Engine (DE) and SPV generator in a hybrid microgrid with both AC and DC loads. The control strategy is associated with instantaneous power flow control to a Non-critical load (NCL) followed by fulfilling the Critical Load (CL) by SPV generator. A control system is recommended to govern the individual power flow from SPV generator and Diesel Engine resulting in control of real power and frequency with efficient energy management which have been described in next sections.

#### **2.1 SYSTEM DESCRIPTION**

The composition of proposed hybrid microgrid system comprises of SPV generator, DE, CLs and NCLs as shown in Fig. 1. The entire system has been modelled and simulated using MATLAB Simulink in the present work. The proposed controller have all the compulsory data about bus of CLs and SPV generator & NCLs. In grid connected mode it does not need more controlling strategy but in islanded mode of operation all the controlling is necessary and decision making to be a stable and continuous operation. In proposed system, DC load (NCLs) is fulfilled by the SPV power only, so it is connected on DC link while 3-phase AC load (CLs) are connected on the common coupling point (CCP) because it will fulfill by the SPV & DE power. Function and modeling of each individual unit and the controlling scheme by proposed controller to regulate frequency and power are discussed in further section. Specifications of elements used in MATLAB

simulation is given in detail as in Table 2.1.

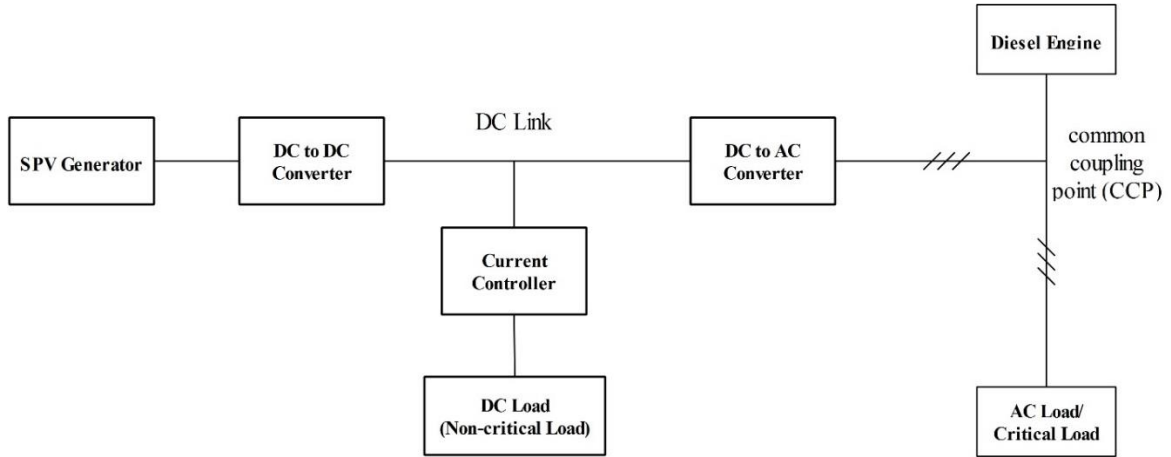

Fig. 1 Proposed SPV-DG Hybrid Microgrid without Storage system.

Table 2.1 Specification of components used in Simulink model.

S. N.	System Component	Specification
1.	SPV generator	$V_{oc} = 840$ V; $I_{sc} = 98.4$ A; $P_{mpp} = 6.552$ kW; $V_{mpp} = 711$ V; $I_{mpp} = 92.16$ A.
2.	DE generator ( synchronous generator based)	$P_{nom} = 6.5$ kW; $V_{l-l} = 430$ V; $F_{nom} = 50$ Hz
3.	AC loads (3-phase)	$P_{max} = 6.5$ kW; $V_{nom} = 430$ V; $F_{nom} = 50$ Hz
4.	DC loads (1-phase)	$P_{max} = 6.5$ kW; $V_{nom} = 710$ V.
5.	Current controller	Neuro-PI technique based controller; $K_p = 1$ ; $K_i = 20$ .
6.	DC –DC converter(MPPT)	$L = 0.47$ mH; $C_{out} = 0.1$ mF.
7.	DC- AC converter	$V_{i/p} = 710$ V; $V_{o/p} = 430$ V; $F_{nom} = 50$ Hz.
8.	DC link	DC link voltage= 710 V

### 2.1.1 Relation between Power deviation and Frequency

Change in frequency from its rated value can be termed as the frequency deviation ( $\Delta f$ ) and the change in power is a difference between the generated real power  $P_G$  and the load power  $P_L$  which include frequency dependent and independent load. Consequently, the gain of the system,

if there is change in frequency of system to per unit deviation in active power [1], can be explained by equation as

$$G_{SYS}(s) = \frac{\Delta f}{\Delta P_L - \Delta P_G} = \frac{1}{D + \frac{2H*s}{f_{sys}}} = \frac{K_{PS}}{1 + s*T_{PS}} \quad (2.1)$$

Where,

$$K_{PS} = (1 / D)$$

$$T_{PS} = 2H/D * f_{sys}$$

D & H = system constant

f<sub>sys</sub> = system frequency (Hz).

### 2.1.2 Diesel Generator module

Input fuel to the diesel generator is controlled by the governor through a valve mechanism controlling the fuel that will regulate the power generated by diesel generator, and finally delivers the essential power to achieve the fluctuation in power at load end. The transfer function of diesel generator presented as equation as per [1].

$$G_{DG}(s) = \frac{K_{DG}}{1 + s*T_{DG}} = \frac{\Delta P_{DG}}{\Delta F} \quad (2.2)$$

Where,

$\Delta P_{DG}$  = change in diesel power

$\Delta F$  = change in frequency

$K_{DG}$  = system constant

$T_{DG}$  = time constant of system.

### 2.1.3 SPV Generator module

A SPV module or panel contain a number of photovoltaic (PV) cells connected in parallel & series arrangement. These PV cells generate DC current and DC voltage at junction due to semi-conductive property when light falls on those cells. The current generated by a cell have non-linear characteristics against the voltage of panel and highly dependent on solar irradiance and cell temperature. Single diode model and I-V characteristic of an SPV cell are shown in fig.2 & fig.3

The SPV generator may be represented by a diode model [27], as per this reference the output current of SPV generator can be expressed as

$$i = I_{ph} - I_0 \left( \exp \left( \frac{V+iR_S}{n_s V_t} \right) - 1 \right) - \frac{V+iR_S}{R_{sh}} \quad (2.3)$$

Where,  $n_s$  is numbers of series cell,  $I_{ph}$  is photocurrent,  $I_0$  is dark saturation current,  $V_t$  is junction thermal voltage, series resistance of cell ( $R_s$ ), shunt resistance of cell ( $R_{sh}$ ),  $V$  is terminal voltage of SPV generator.

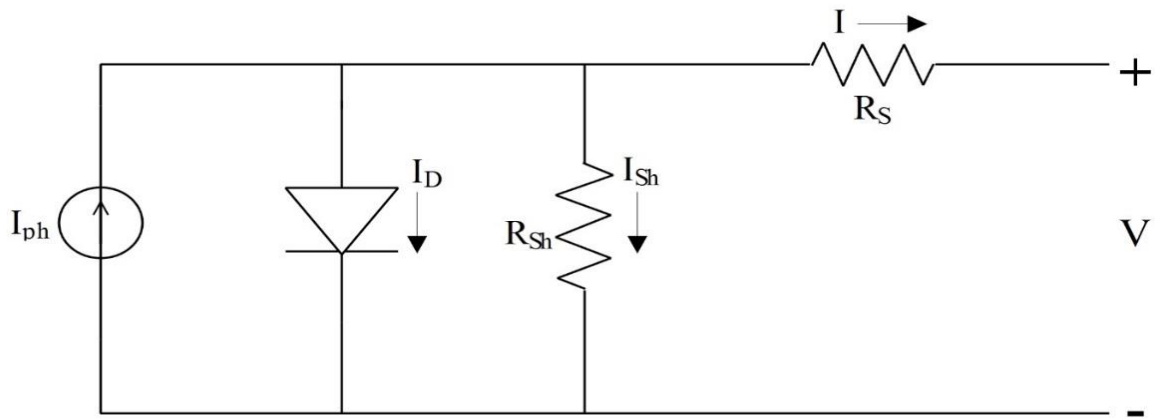

Fig. 2. Single Diode based Solar Cell model

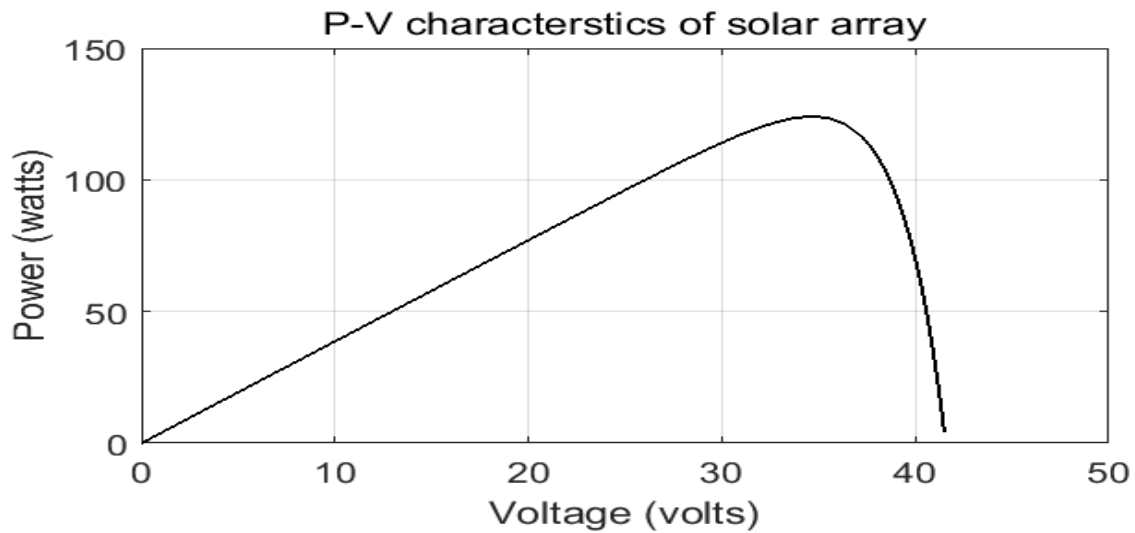

Fig. 3 P-V characteristics of Solar Panel

The photo current is expressed as

$$I_{ph} = I_0 \exp \left( \frac{V_{oc}}{n_s V_t} \right) + \frac{V_{oc}}{R_{sh}} \quad (2.4)$$

Where,  $V_{oc}$  is the open circuit voltage of SPV generator.

And junction thermal voltage may be expressed as

$$V_t = \frac{A k T_{stc}}{q} \quad (2.5)$$

Where, A is ideality factor, q is charge of electron,  $T_{stc}$  is standard working temperature, k is Boltzmann's constant. Dark saturation current may be expressed as

$$I_0 = (I_{sc} - (\frac{V_{oc} - I_{sc}R_s}{R_{sh}})) \exp(\frac{-V_{oc}}{n_s V_t}) \quad (2.6)$$

Where,  $I_{sc}$  is short circuit current of SPV generator.

The output power of SPV generator may be expressed as

$$P_{spv} = f(V_{dc}, T, G) = V_{dc} * i \quad (2.7)$$

Where,  $V_{dc}$  is DC terminal voltage, T is cell temperature and G is solar irradiance

#### 2.1.4 Dynamic modulation of MPPT current

In this proposed work, the MPPT current is being divided to share the load instead of de-rating the MPPT current by applying the Kirchhoff's Current Law at the DC link node of the system. We can understand that the current flowing in to DC link will be divided into two currents, one is  $I_{CL}$  (critical load current) and another is  $I_{NCL}$  (non-critical load current). This controlling method is explored in next section. The current sharing scheme may be represented as shown in Fig.4.

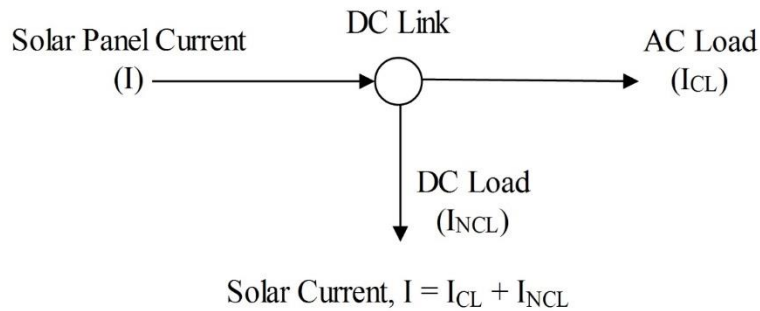

Fig. 4. Modulation of MPPT current.

## 2.2 FUNCTION OF PROPOSED CONTROLLER

For the maximum utilization of the energy generated by the SPV generator, first we assume that the rating of the SPV generator is more than total critical load demand power. In a sunny day the critical load can be fulfilled by the SPV generation.

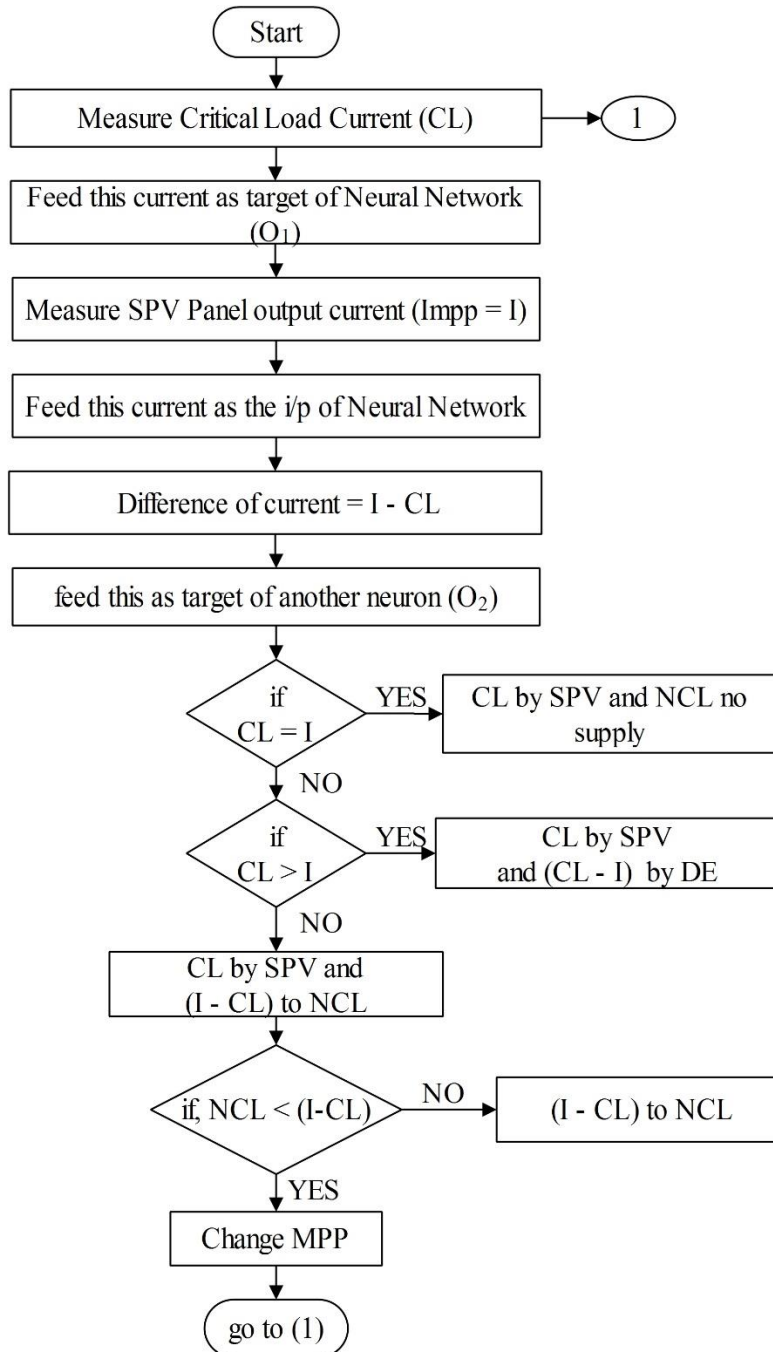
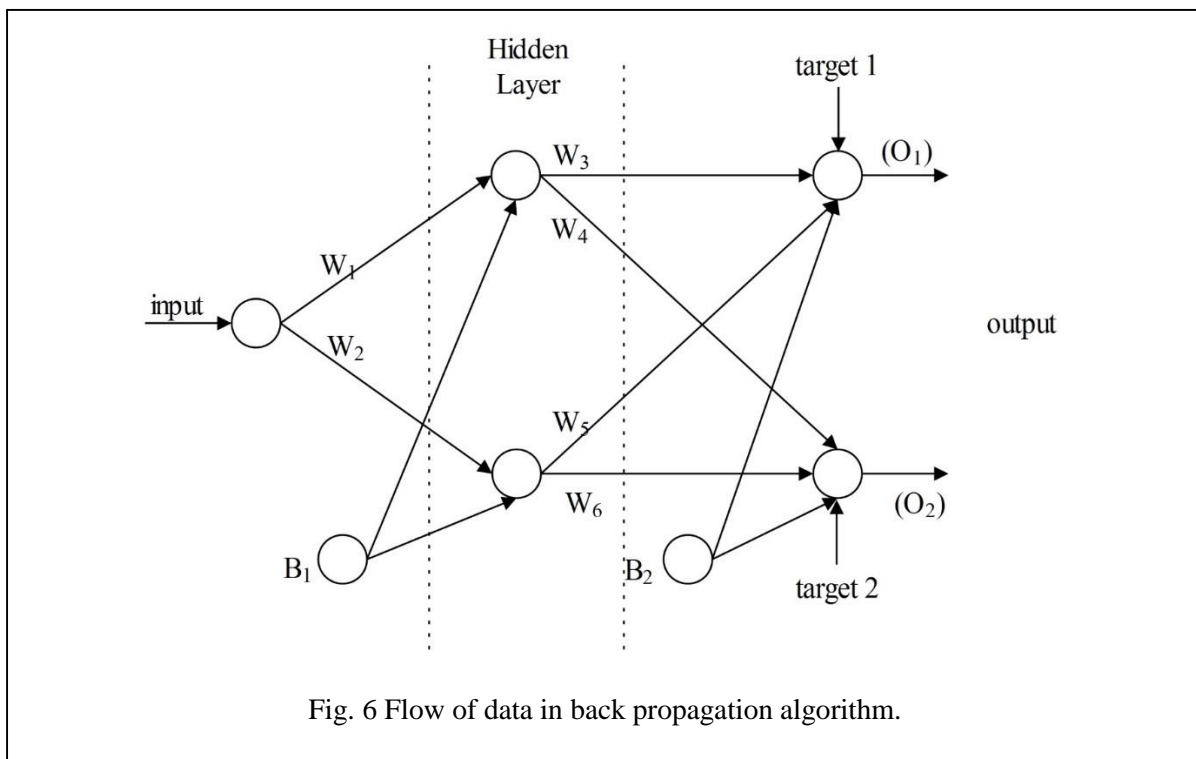

Fig. 5 Control flow chart showing function of controller

In case, the power generated by the SPV is less than critical load demand, then remaining critical load will be fulfilled by the DE and no power will be delivered to NCLs. In another situation, if the power generated by the solar is greater than the critical load demand then remaining power of the SPV will be supplied to the available non-critical load (NCLs) (e.g. dc load as battery of electric vehicle or simple vehicle or any dc load). If the remaining power of SPV is more than the available AC load (CLs), in that situation it will go to shift the position of operating point of MPPT. All these processes may be understood by the flow chart shown in Fig.5.

### 2.2.1 Back Propagation Algorithm

Artificial Neural Network (ANN) has seen an explosion of interest over the last few years and is being magnificently, applied across an extraordinary range of problem domains, in areas as diverse as finance, medicine, engineering, geology and physics. Artificial Neural Network is an important data acquisition tool being used for different field of operation. It is a challenge to design a machine which may emulate the activities of human brain and capable to acquire. ANN usually learn by examples. If ANN is trained with adequate example, it might be capable to classify and even discover new leanings in data mining. Basic ANN have three layers, input layer, output layer and hidden layer. Each layer may contain one or more than one neurons and there may be any



connection among neurons of these three layer. Nodes from hidden layer are connected to the nodes from output layer. The connection represent weight between neurons.

Idea behind Back Propagation (BP) algorithm of neural network is very simple, ANN's output is calculated with respect to output targeted. If result is not adequate, weight (connection) between neurons are updated and process is repetitive again and again till difference b/w target and output is within tolerable limit. If there is implementation of multilayer perceptron with BPA, there exists an evolutionary strategy to overcome the local minima. Signal/data flow in neural network may be represented as shown in Fig.6.

### 2.2.2 Description of proposed controller

In this proposed Neuro-PI controller, the value of current which flows through the NCL is being calculated through BPA. Value of current through NCL is dependent upon the MPPT current and CL current. It means MPPT current will be shared by the NCL current followed by fulfilling the CL current. To calculate the NCL current, value of MPPT current is fed as input to the neural network system and CL & NCL current is fed as target to the system. Output of the BPA is applied to PI controller which will generate a reference signal for the PWM generator. Hence at the final stage of controller there is DC-DC converter (buck converter), being controlled by the output of PWM generator. So the power supplied to the NCL is being controlled by controlling the voltage across NCL followed by fulfilling the CL power demand. All the process of proposed controller can be easily understood through block diagram mentioned in Fig.7.

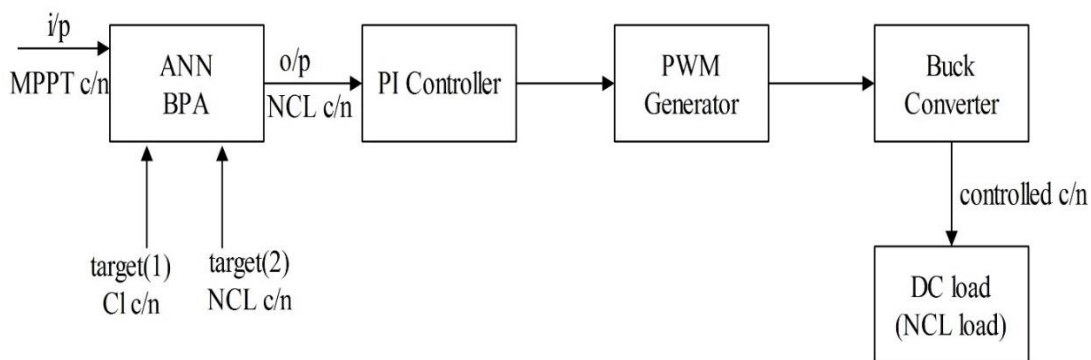

Fig. 7. Block diagram presentation of proposed controller.

A typical circuit diagram of controlled Buck Converter is shown in fig.8. Where Neuro-PI controller is being used to govern the switching time of switch (MOSFET) by which the output voltage is controlled. Value of  $K_p$  and  $K_i$  of PI controller & inductor (L) and capacitor (C) used in proposed controller is mentioned in Table-2.1, L and C can be expressed as eq (2.8) & eq (2.9) as in [28].

$$L = \frac{V_{out}(1-D)}{f_{sw} * \Delta i_L} \quad (2.8)$$

$$C = \frac{V_{out}(1-D)}{8.L(n.f_{sw})^2 \Delta V_c} \quad (2.9)$$

Where,

$V_{out}$  = Output voltage

D = duty cycle of switch.

$f_{sw}$  = switching frequency

$\Delta i_L$  = change in inductor current

$\Delta V_c$  = change in voltage across capacitor.

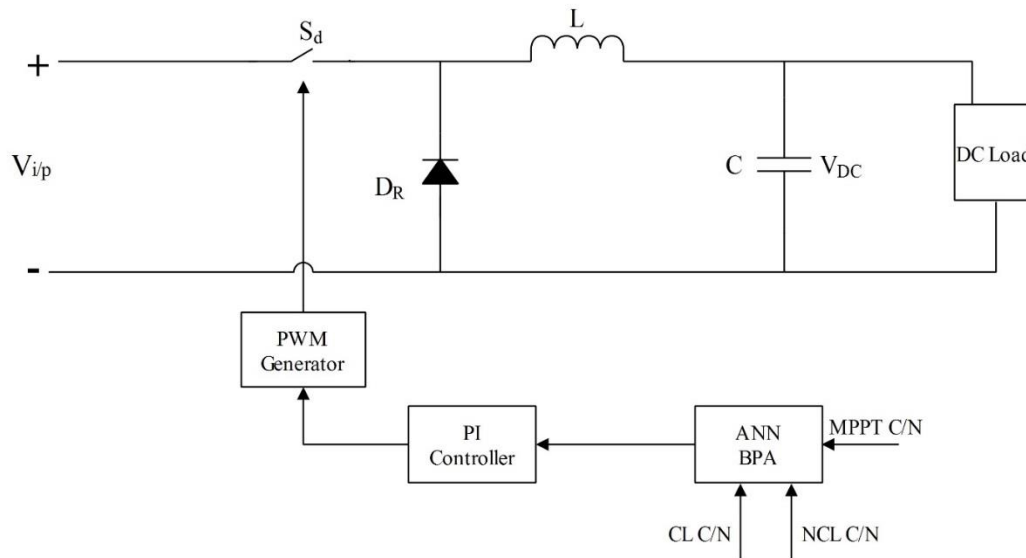

Fig. 8. Typical circuit diagram of Buck Converter with Neuro-PI controller.

## 2.3 DISCUSSION ON RESULTS

In proposed microgrid system, a critical load has been considered having 5kW capacity and the fluctuation in critical load is assumed up to  $\pm 30\%$  of rated capacity. Therefore, in proposed model an SPV generator is being used having power capacity of 6.5 kW at 1000 W/m<sup>2</sup> irradiance and 25°C cell temperature. The results are discussed considering the following scenarios 1 & 2.

### 2.3.1 Scenario-1

In this case, it is assumed that the critical load is active at rated load and having maximum limit (+30%) of its fluctuation. It means that total power demand is 6.5 kW. Hence the total power generated by the SPV generator is being supplied to meet the critical load i.e. 6.5 kW. So there is no excess power is reserved to deliver as NCL power. In this scenario the virtual inertia effect of SPV generator can be realized to meet the CL demand and when surplus power is available can be treated as spinning reserve capacity. In Fig.9 it is shown that the CL power is increasing from 5kW to 6.5 kW gradually which is the highest capacity of the SPV generator. So total generated power of SPV system is transferred to CL while no power is being transferred to NCL.

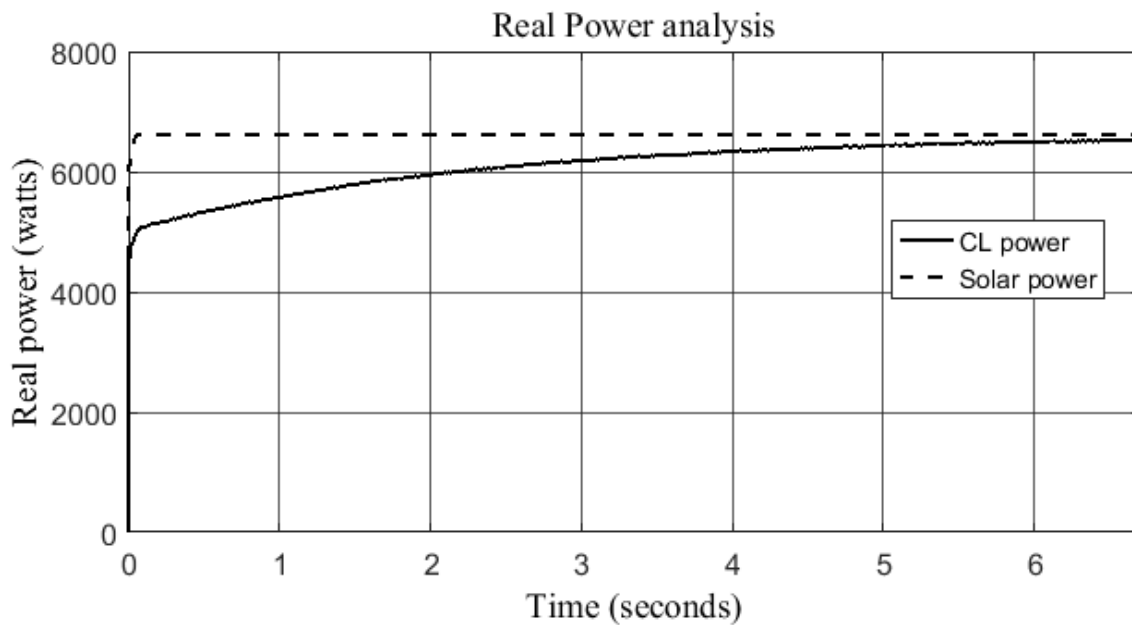

Fig. 9. Virtual Inertia effect in SPV generator.

### 2.3.2 Scenario-2

In the second case, it is assumed that the CL demand is lower than the power generated by SPV generator. So in this condition, surplus energy being generated by the SPV generator is transferred to the available NCL i.e. DC load connected at DC link of the system. The power generated by SPV system, power consumed by the CL and NCL are shown in Fig.10. In this figure it is shown that how the power is distributed to available CL and NCL. At starting time of simulation there is some fluctuation in NCL power, it is due to the number of cycle used for the calculation of exact value of NCL power by current controller. After 2.5 seconds there is no NCL power available and increase in CL demand is observed, so now there is de-rating of MPPT condition to meet the CL demand only.

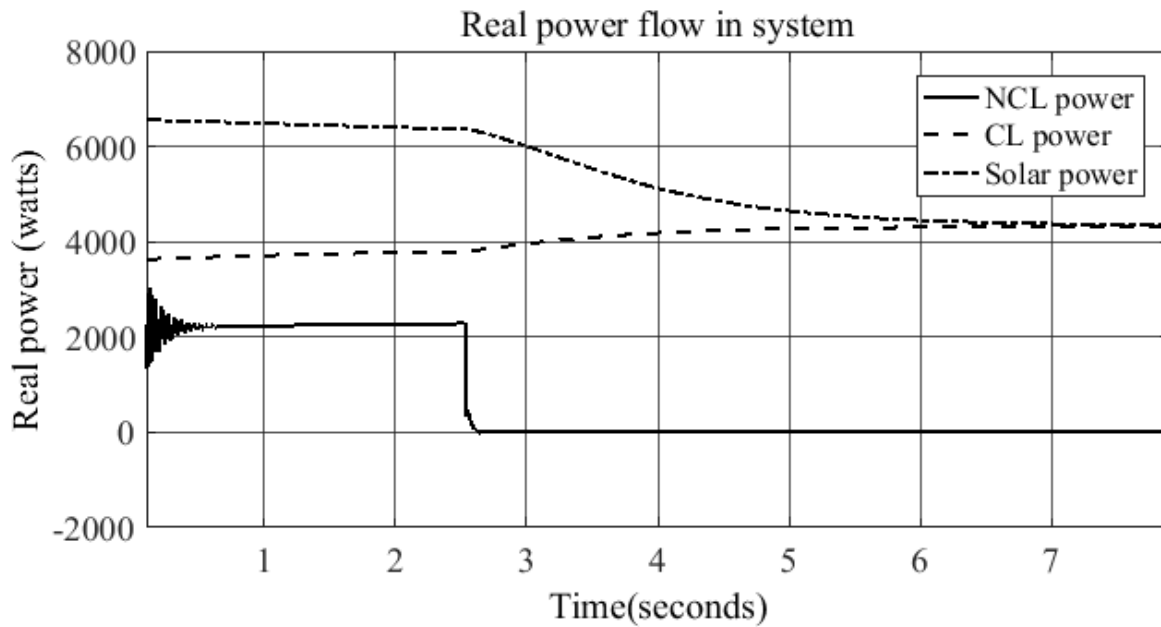

Fig. 10. Flow of power in the proposed system.

## 2.4 CONCLUSIONS

In this chapter, the feasibility of the novel control scheme by using SPV generator as a time variable source is verified. It is found that the frequency deviation and real power can be controlled on the basis of artificial neural network mechanism. The novel approach for controlling the power generated by SPV by an adaptive Neuro-PI controller is proposed and found promising due to its

learning capability resulting in automated decision for the flow of power to NCL according to scenario of power demand and generation. The results obtained from the simulation of the proposed system are found acceptable in all the considered situations.

## Chapter 3

### **Adaptive neuro fuzzy controller for real power control of storage free hybrid microgrid**

---

A Smart microgrid can be operated in more economical way by using renewable energy sources through maximum utilization algorithm at reduce use of conventional sources based on fossil fuels. Real power control flow of hybrid microgrid in islanded mode is quite different than in grid connected operating mode. In this proposed paper, it is trying to show virtual inertia effect in Solar Photovoltaic (SPV) generator. This paper is an effort to suggest an Adaptive Neuro fuzzy Inference (ANFI) Logic based control system having variable reference input which make it able to model an uncertainty and non-linearity. To show the virtual inertia effect of SPV generator an ANFI based controller is being proposed which coordinate the control scheme of SPV and Diesel Engine (DE) based hybrid microgrid having both AC and DC load. An efficient energy management control strategy is proposed which control the individual power flow of SPV generator and DE to fulfill the real power demand by Critical Load (CL). To regulate the frequency deviation and power demand by proposed controller, modeling and function of individual unit are conversed in additional sections.

#### **3.1 SYSTEM DESCRIPTION**

The proposed storage free hybrid microgrid system and its composition is shown in Fig. 11. It consists of SPV generating unit, DE, DC to AC converter, DC to DC converter, Current controller, AC loads (CLs) and DC loads (NCLs). All the essential data about both generating unit and loads which is helpful to take the decision by proposed controller. In grid tied operating condition there is no more need of critical controlling scheme than in islanded operating mode where it needs critical and complex controlling scheme to make it self-decision making system for a continuous and stable operation. A DC to DC converter is simulated as MPPT, which is basically a Buck-Boost converter. Switching control of MPPT is on the basis of P&O algorithm. A voltage source converter is simulated as DC to AC converter, the switching control of this converter is controlled as per the feedback signal feeding from the common coupling point. To supply the power to the

NCLs a current controller have simulated on the principle of ANFI system. Specifications of the elements simulated in MATLAB Simulink is listed in Table 3.1.

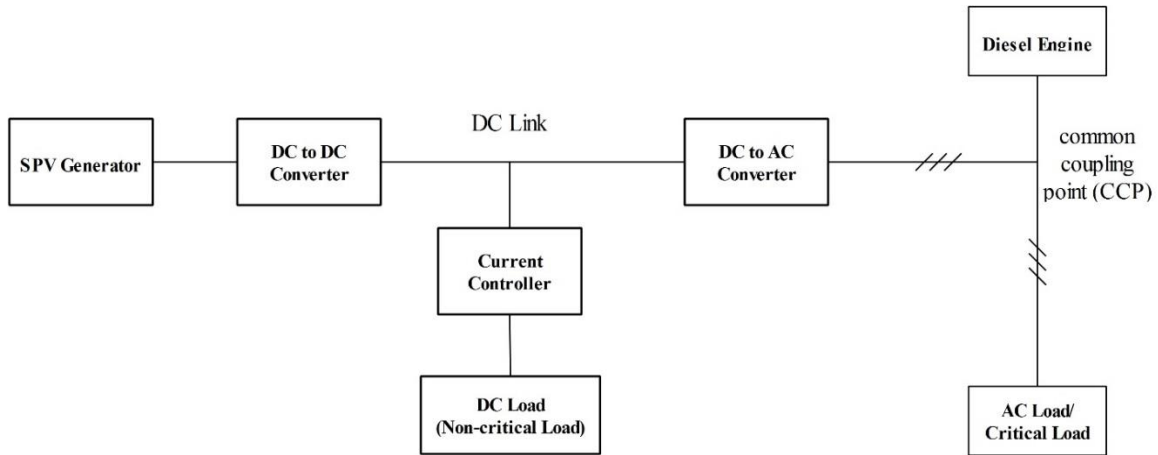

Fig. 11. System Description

Table 3.1 Specifications of components used for model simulation.

S. N.	System Component	Specification
1.	SPV generator	$V_{oc} = 840 \text{ V}$ ; $I_{sc} = 98.4 \text{ A}$ ; $P_{mpp} = 590.2 \text{ kW}$ ; $V_{mpp} = 711 \text{ V}$ ; $I_{mpp} = 92.16 \text{ A}$ .
2.	DE generator(Synchronous generator based)	$P_{nom} = 600 \text{ kW}$ ; $V_{l-l} = 430 \text{ V}$ ; $F_{nom} = .50 \text{ Hz}$
3.	AC loads ( 3- phase)	$P_{max} = 590 \text{ kW}$ ; $V_{nom} = 430 \text{ V}$ ; $F_{nom} = 50 \text{ Hz}$
4.	DC loads ( 1- phase)	$P_{max} = 590 \text{ kW}$ ; $V_{nom} = 710 \text{ V}$ .
5.	Current controller	ANFIS technique based controller
6.	DC –DC converter(MPPT)	$L = 0.47 \text{ mH}$ ; $C_{out} = 0.1 \text{ mF}$ .
7.	DC- AC converter	$V_{i/p} = 710 \text{ V}$ ; $V_{o/p} = 430 \text{ V}$ ; $F_{nom} = 50 \text{ Hz}$ .
8.	DC link	DC link voltage= 710 V

### 3.1.1 Relation between real power & frequency deviance

Frequency deviance ( $\Delta f$ ) may be understand as a variation in frequency from its predefined

range/value and power aberration can be understand as the difference in power between the power of generating unit  $P_G$  and power demand by load  $P_L$  which include load dependent and non-dependent on frequency. Therefore, the gain of the system followed by the fluctuation in frequency and active power [1] can be explicated as following:

$$G_{SYS}(s) = \frac{\Delta f}{\Delta P_L - \Delta P_G} = \frac{1}{D + \frac{2Hs}{f_{sys}}} = \frac{K_{PS}}{1 + sT_{PS}} \quad (3.1)$$

Where,  $K_{PS} = (1 / D)$  and  $T_{PS} = 2H/D * f_{sys}$

$D$  &  $H$  are system constant,

$f_{sys}$  = system frequency

### 3.1.2 SPV generator module

A SPV panel generate DC current which depends on irradiance ( $G$ ) & cell temperature ( $T$ ) and thus it generate voltage panel terminal. So single diode model of SPV panel may be characterized as a current controlled voltage source as in Fig. 12.

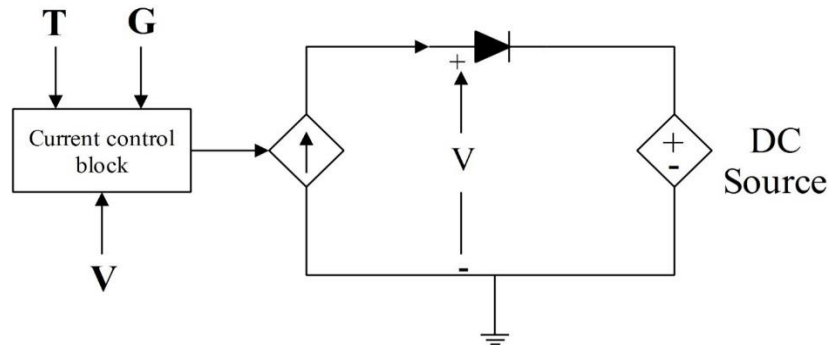

Fig. 12. SPV panel as controlled source.

The modelling of solar photo voltaic (SPV) panel require the parameters which depend on the physical and electrical property of material used in manufacturing of SPV panel. Typically, manufacturers do not share detailed properties of material being used, excluding some electrical property such as open-circuit voltage ( $V_{oc}$ ), short-circuit current ( $I_{sc}$ ), voltage at maximum power point ( $V_{mpp}$ ), current maximum power point ( $I_{mpp}$ ) and maximum power ( $P_m$ ). To calculate more properties of panel, it is necessary to determine the value of some physical parameter as series resistance of SPV cell ( $R_s$ ), parallel resistance of SPV cell ( $R_{sh}$ ) and ideality factor of diode

(n). The SPV array based on single diode model [28] is in consideration, as per the reference the Dark saturation current ( $I_0$ ) may be formulated as:

$$I_0 = \frac{[n_s I_{sc(stc)} \{1 + K_i(T - T_s)\} \{R_{sh} + R_s\} - n_p V_{oc(stc)} \{1 + k_v(T - T_s)\}]}{n_s n_p R_{sh} [e^{((qV_{oc(stc)} \{1 + K_v(T - T_s)\}) / (nkTn_s))} - e^{((qI_{sc(stc)} \{1 + K_i(T - T_s)\} R_s) / nkTn_p)}]} \quad (3.2)$$

Where,  $n_s$  is number of series cells,  $n_p$  is number of parallel cells,  $I_{sc(stc)}$  is short circuit current at STC.,  $K_i$  is current coefficient,  $K_v$  is voltage coefficient,  $R_s$  is series resistance,  $I_{ph}$  is photocurrent,  $V_t$  is junction thermal voltage,  $R_{sh}$  is shunt resistance  $q$  is charge of electron,  $T_s$  standard test temperature,  $T$  is instantaneous temperature of cell. The photo current ( $I_{ph}$ ) is formulated as

$$I_{ph} = \frac{[n_s I_{sc(stc)} \{1 + K_i(T - T_s)\} \{R_{sh} + R_s\} - n_p V_{oc}] [e^{((qV_{oc(stc)} \{1 + K_v(T - T_s)\}) / (nkTn_s))}]}{n_s R_{sh} [e^{((qV_{oc(stc)} \{1 + K_v(T - T_s)\}) / (nkTn_s))} - e^{((qI_{sc(stc)} \{1 + K_i(T - T_s)\} R_s) / nkTn_p)}]} G_{nom} + \frac{G n_p V_{oc(stc)} \{1 + k_v(T - T_s)\}}{n_s R_{sh} G_{nom}} \quad (3.3)$$

Where,  $G$  is instantaneous solar irradiance and  $G_{nom}$  is standard solar irradiance.

Junction thermal voltage may be expressed as

$$V_t = \frac{n k T_s}{q} \quad (3.4)$$

Where,  $n$  is ideality factor,  $k$  is Boltzmann's constant,  $G_{nom}$  is nominal irradiance,  $V_{oc(stc)}$  is open circuit voltage at standard test condition. Current output of SPV generator can be formulated as

$$I = \frac{[n_s I_{sc(stc)} \{1 + K_i(T - T_s)\} \{R_{sh} - R_s\} - n_p V_{oc}] [e^{((qV_{oc(stc)} \{1 + K_v(T - T_s)\}) / (nkTn_p))} - 1] G}{n_s R_{sh} [e^{((qV_{oc(stc)} \{1 + K_v(T - T_s)\}) / (nkTn_s))} - e^{((qI_{sc(stc)} \{1 + K_i(T - T_s)\} R_s) / (nkTn_p))}] G_{nom}} - \frac{[n_s I_{sc(stc)} \{1 + K_i(T - T_s)\} \{R_{sh} + R_s\} - n_p V_{oc}] [e^{((q(n_p V + n_s I R_s)) / (nkTn_s n_p))} - 1]}{n_s R_{sh} [e^{((qV_{oc(stc)} \{1 + K_v(T - T_s)\}) / (nkTn_s))} - e^{((qI_{sc(stc)} \{1 + K_i(T - T_s)\} R_s) / (nkTn_p))}] + \frac{G n_p V_{oc(stc)} \{1 + k_v(T - T_s)\}}{n_s R_{sh} G_{nom}} - \frac{n_p V + n_s I R_s}{n_s R_{sh}} \quad (3.5)$$

Power generated by SPV  $P_{spv}$  may be formulated as

$$P_{spv} = f(V_{dc}, T, G) = V_{dc} * i \quad (3.6)$$

### 3.1.3 Speed governing module of Diesel Generator

In speed governor of DE, input fuel is controlled by a valve mechanism controlling scheme which will adjust the power generated by DE, and finally DE deliver the necessary power to damp out the fluctuation in power demanded by load. The gain of diesel generator may be formulated as in equation (14) is as per [1] followed by a disturbance.

$$G_{DG}(s) = \frac{K_{DG}}{1+sT_{DG}} = \frac{\Delta P_{DG}}{\Delta F} \quad (3.7)$$

Where,

$K_{DG}$  = constant of Diesel generator

$T_{DG}$  = time constant of Diesel generator

Representation of speed governor is illustrated in Fig.13 and can be formulated as:

$$G_{DE}(s) = \frac{P_{mec}}{W_{ref} - W} \quad (3.8)$$

Where,

$P_{mec}$  = Mechanical output power(PU)

$W_{ref}$  = Reference angular speed (PU)

$W$  = Input angular speed (PU)

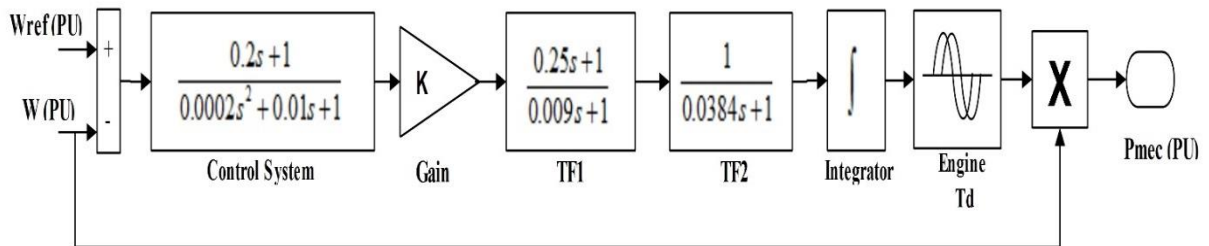

Fig. 13. Modelling of speed governor of Diesel Engine

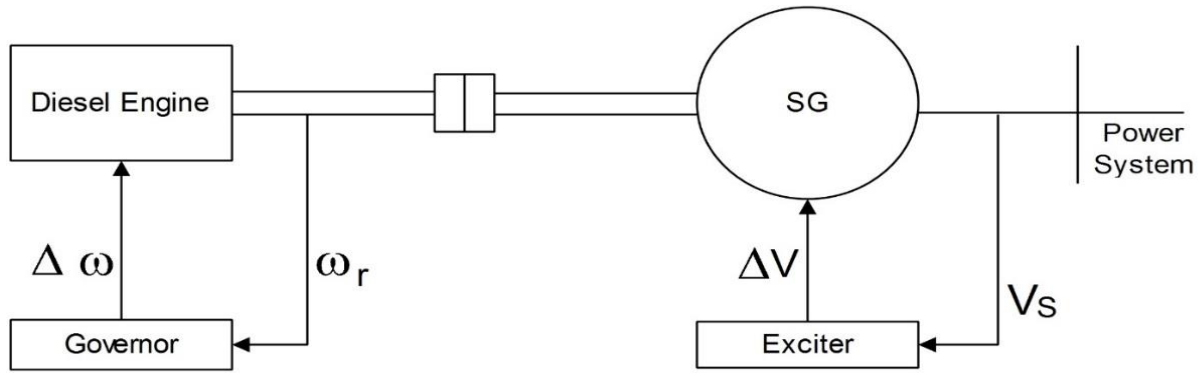

Fig. 14. Diesel Engine based Synchronous Generator.

A diesel engine based synchronous generator (SG) is represented in Fig.14. The mechanical power generated by DE is fed to the SG. While the DE and SG is controlled individually by its governor & exciter through negative feedback. Electrical power generated by SG is fed to power system (microgrid) [29].

### 3.1.4 MPPT current flow control

Apart from de-rating of maximum power point (MPP) condition of SPV array, the current generated by SPV generator is being divided into two part, one as CL current ( $I_{CL}$ ) and second as NCL current ( $I_{NCL}$ ), on the basis of Kirchoff's Current Law at the DC link node of the system. The controlling scheme is explained in next section.

## 3.2 FUNCTION OF PROPOSED CONTROLLER

### 3.2.1 Adaptive Neuro-Fuzzy Inference System

An Adaptive Neuro learning technique mechanism is similar to Neural Network (NN). An adaptive learning method provides a scheme to fuzzy modeling technique to acquire statistics of set of data. The parameters of membership function is being computed by fuzzy logic tool box which permit the linked Fuzzy Inference System (FIS) to follow the input and output set of data. The function of fuzzy logic toolbox that achieves the adjustment of membership function is termed as adaptive neuro fuzzy inference system (ANFIS). By using an available data set of input/output, ANFIS creates a FIS, parameters of membership function of constructed FIS are being regulated either by using a back propagation algorithm (BPA) or by combining with least square method.

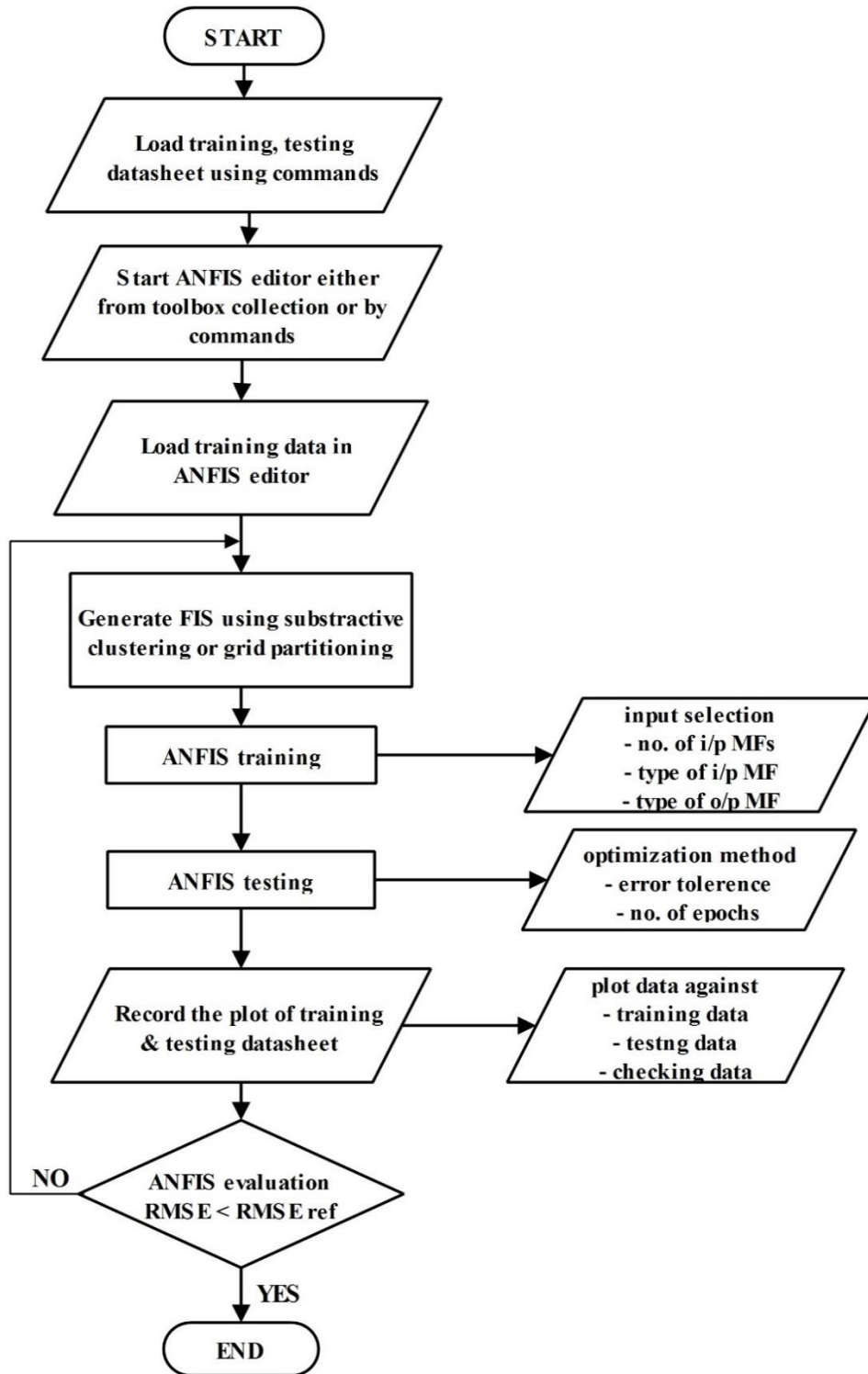

Fig. 15. ANFIS flow chart

ANFIS and neuro fuzzy designer apply fuzzy inference technique to data modeling [30] and [31]. Data flow and process of ANFIS is shown in Fig. 15.

### 3.2.2 Buck converter

A buck converter is a DC to DC conversion device where input voltage is converted in output voltage at low value than input always by using its switching frequency. Buck Converter consists one or more controlled switch with a controlling scheme and an external inductor which offer a flexible operation. The external inductor provide an efficient and optimized power supply with a better flexible, size, and economy. Relation between input and output voltage in terms of duty cycle of switch can be expressed as in equation (18) and circuited as in Fig.16.

$$V_o = (V_i - V_q)D - V_d(1 - D) \quad (3.8)$$

Where  $V_i$ ,  $V_o$ , and  $D$  are input voltage output voltage and duty cycle respectively while  $V_q$  and  $V_d$  are switch voltage and diode voltage.

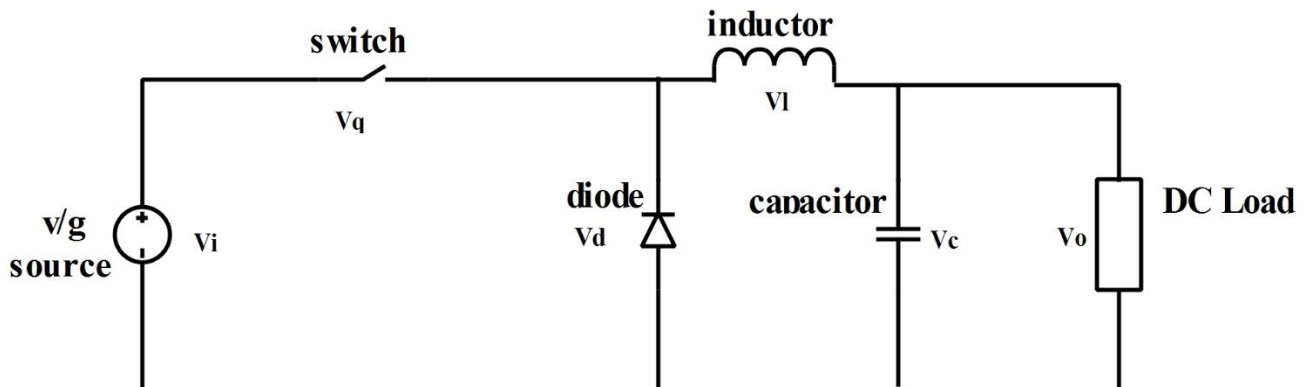

Fig. 16. Buck converter

### 3.2.3 Testing and model validation

There are many identification technique based system similar to the modeling methodology of ANFIS. In ANFIS first relate the input data to membership function to find the membership function of output data. Then, it collects the input/output data pattern in a form which is be applied for the training of ANFIS. Then ANFIS may be used to train a FIS model to follow the training data pattern and to regulate the parameter of membership function within the limited error

condition. System error is inversely proportional to the amount of data being learnt to the system. So for the validation of model and testing the structure of proposed model can be represented as in Fig.17.

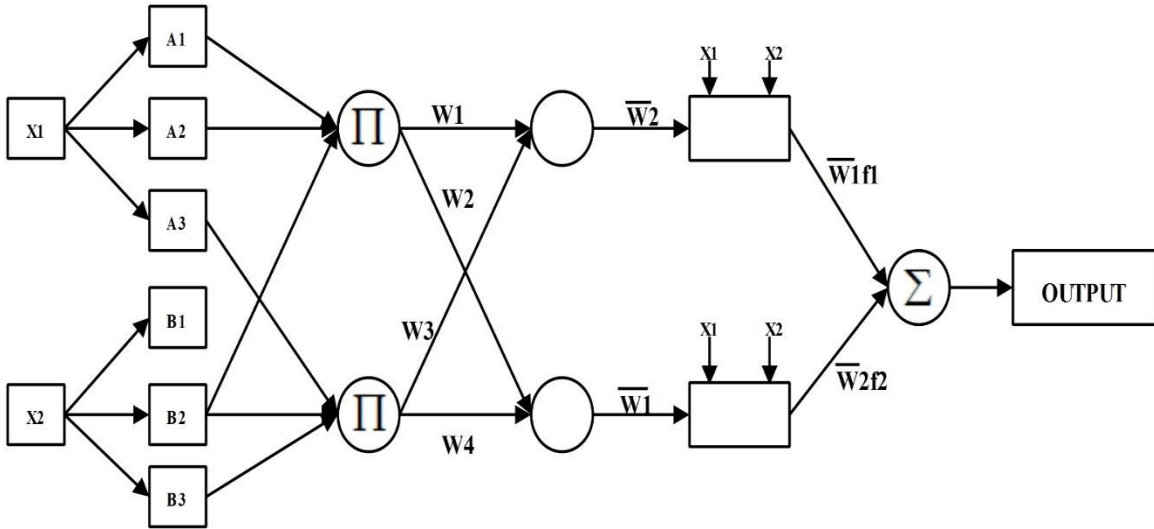

Fig. 17. Structure of ANFIS

Where,  $X_1$  and  $X_2$  are linguistic variable A, B subcategory (property of variables),  $W$  is the weight factor.

### 3.3 DESCRIPTION OF PROPOSED CONTROLLER

#### 3.3.1 Algorithm of proposed controller

For the maximum utilization of the energy generated by the SPV generator and to have an economic hybrid microgrid. A SPV generator is in consideration which power rating is more than peak CL demand (20 percent more than peak CL) it is assumed that in a sunny day SPV generator generate its full power. In power system if load power is more than the generated power, there is fall in voltage of system and if generated power is more than the demand power then there is rise in voltage of system. So this proposed controller works on this topology. In this proposed controller, first it fix reference CL terminal voltage (RCLTV). It takes the decision to share power on the basis of measured CL terminal voltage (CLTV). To control the power flow, duty cycle of buck converter is being controlled. Set the initial value of duty cycle as,  $D = 0$ , change in duty

cycle  $\Delta D = 0.05$ , governor speed,  $w = 1$  p.u., change in speed  $\text{del}w = 0.05$  p.u. If  $\text{CLTV} = \text{RCLTV}$ ,

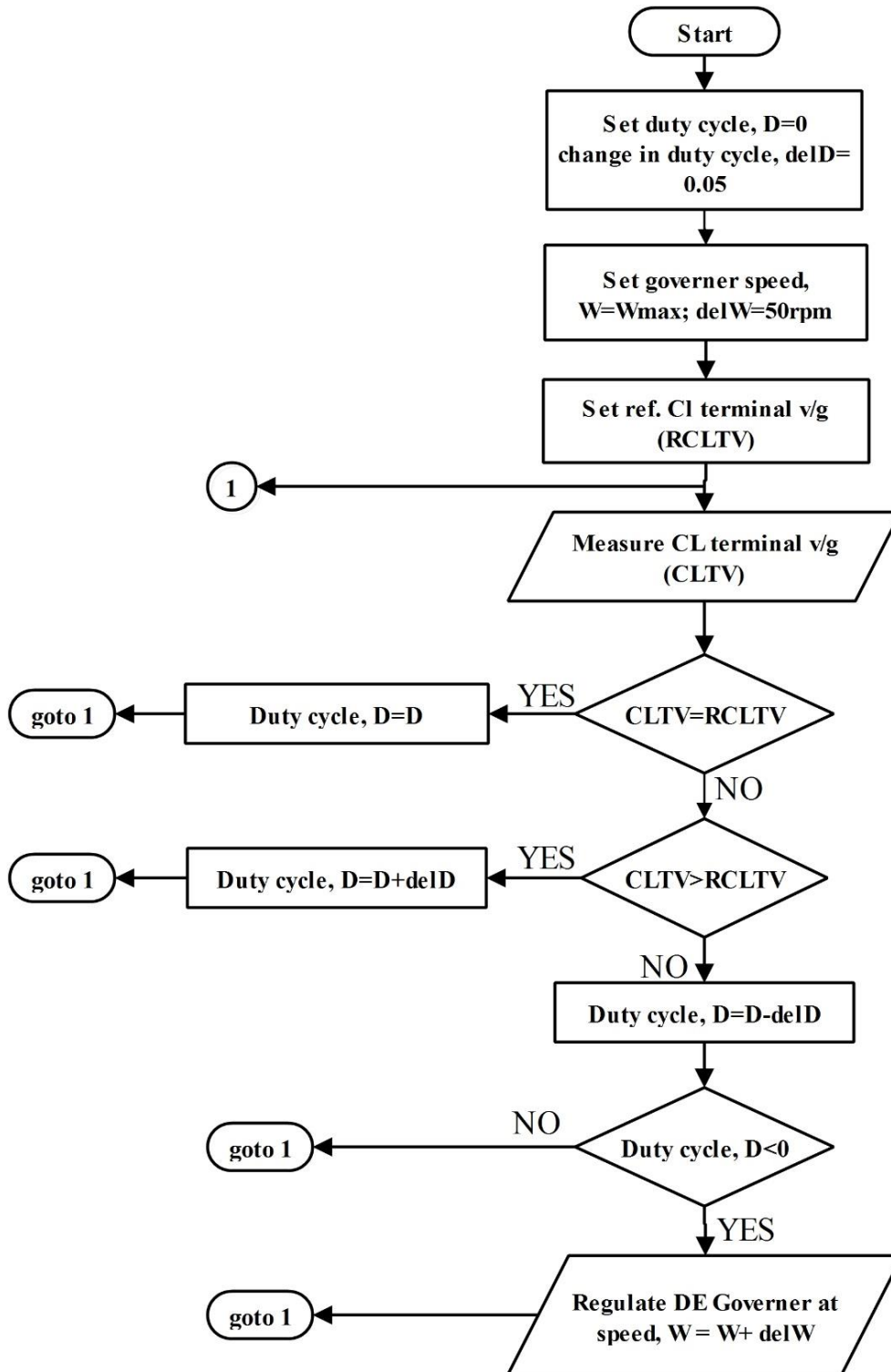

Fig. 18. Flow chart of proposed system

then duty cycle will be as its previous value, if  $CLTV > RCLTV$ , then it will increase  $D$  by  $\Delta D$ , if  $CLTV < RCLTV$ , then it will decrease  $D$  by  $\Delta D$ . if the duty cycle becomes less than zero, it regulate DE at speed of  $w = w + delw$ . All the calculation decision making steps is in an infinite loop till the power system is in ON state. All these processes may be understood by the flow chart shown in Fig. 18.

### 3.3.2 Architecture of proposed controller

In this proposed Adaptive Neuro-Fuzzy controller, there is use of two linguistic variable  $X1$  &  $X2$  where  $X1$  is change in  $CLTV$  while  $X2$  is MPPT voltage. This system contains a huge amount of data related with all the input and output parameters of the system which is use to learn by the system. Both linguistic variable  $X1$  &  $X2$  is fed to the ANFIS, the crisp value of input is fuzzified first, then fuzzified value reach to the inference engine where is rule is selected through ANFIS according to input parameter and its membership function. By using rule base it defines the membership function of output parameter and its fuzzy value. By using de-fuzzification method, it calculate crisp value of output parameter. In proposed system the output parameter of ANFIS defines the value of duty cycle for the DC-DC converter, being used in system. So the DC-DC converter is controlled by the output of ANFIS. Hence the power to NCLs is being controlled by varying its terminal voltage according to the output of buck converter (DC-Dc converter). All the process of proposed controller can be easily understood by the block diagram mentioned in Fig.19.

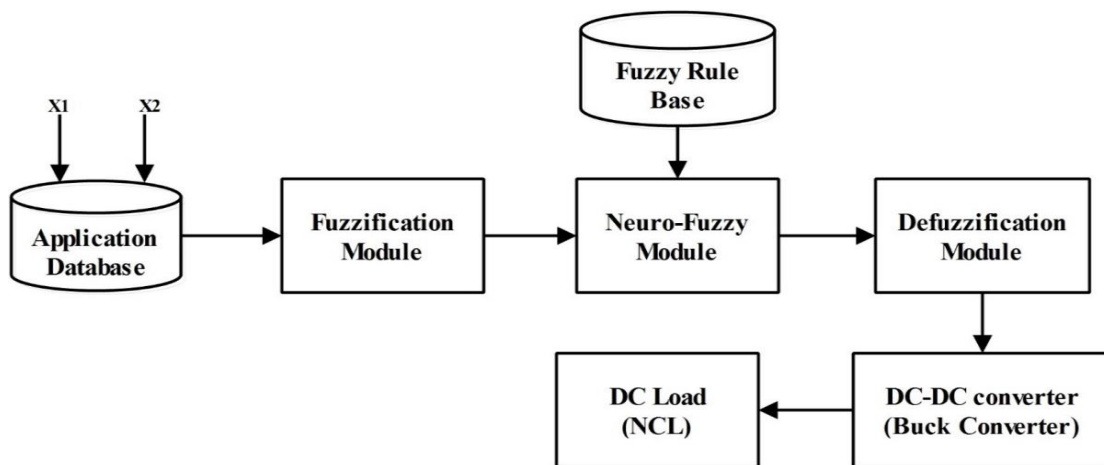

Fig. 19. Architecture of proposed controller

### 3.4 DISCUSSION ON RESULTS

In proposed microgrid system, a critical load has been considered having 5kW capacity and the fluctuation in critical load is assumed up to  $\pm 30\%$  of rated capacity. Therefore, in proposed model an SPV generator is being used having power capacity of 6.6 kW at  $1000 \text{ W/m}^2$  irradiance and  $25^\circ\text{C}$  cell temperature. The results are discussed considering the following scenarios 1 to 5.

#### 3.4.1 Scenario-1

In this case, it is assumed that solar irradiance to the system is  $1000 \text{ W/m}^2$  and cell temperature is  $30^\circ\text{C}$ , so the SPV generator generates its full rated power. Simultaneously the AC load (CL) of the system is also at its full rating. So the 585 kW power generated by the SPV system is totally supplied to CLs which is fixed throughout the simulating time. Frequency at the CL side is observed within 0.2 % of deviation from 50 Hz. In this condition no power is being transferred to DC loads (NCLs). Real power of the AC loads (CLs) fulfilled by the SPV generator and frequency response of the system is shown in Fig. as:

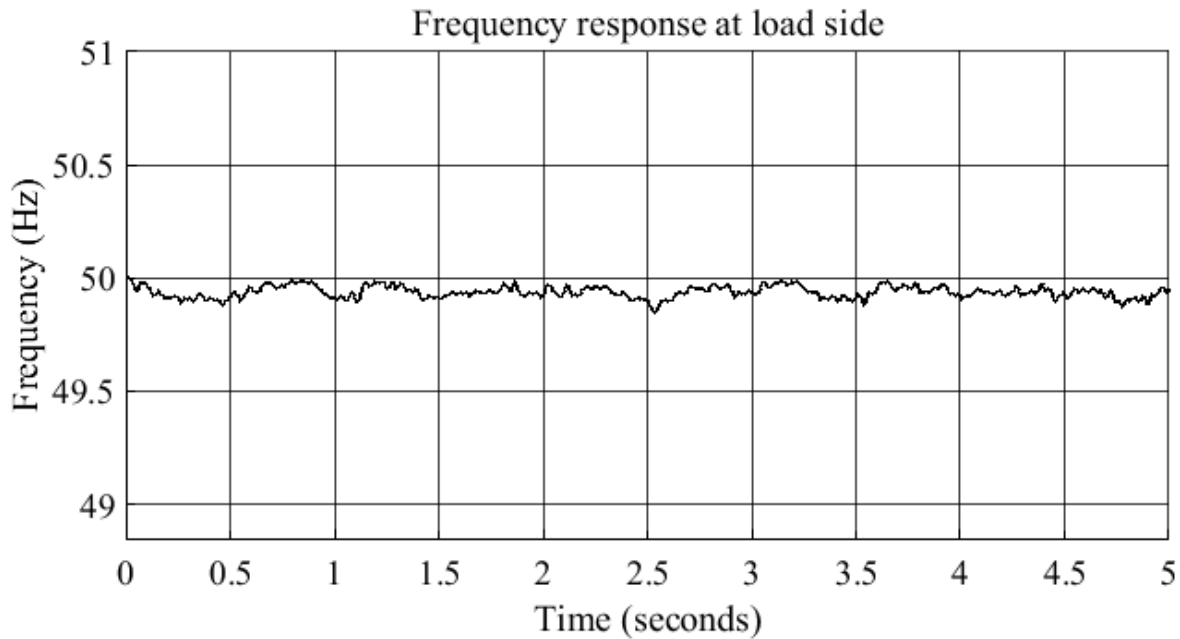

Fig. 20. Frequency response at CL terminal fulfilled by SPV generator.

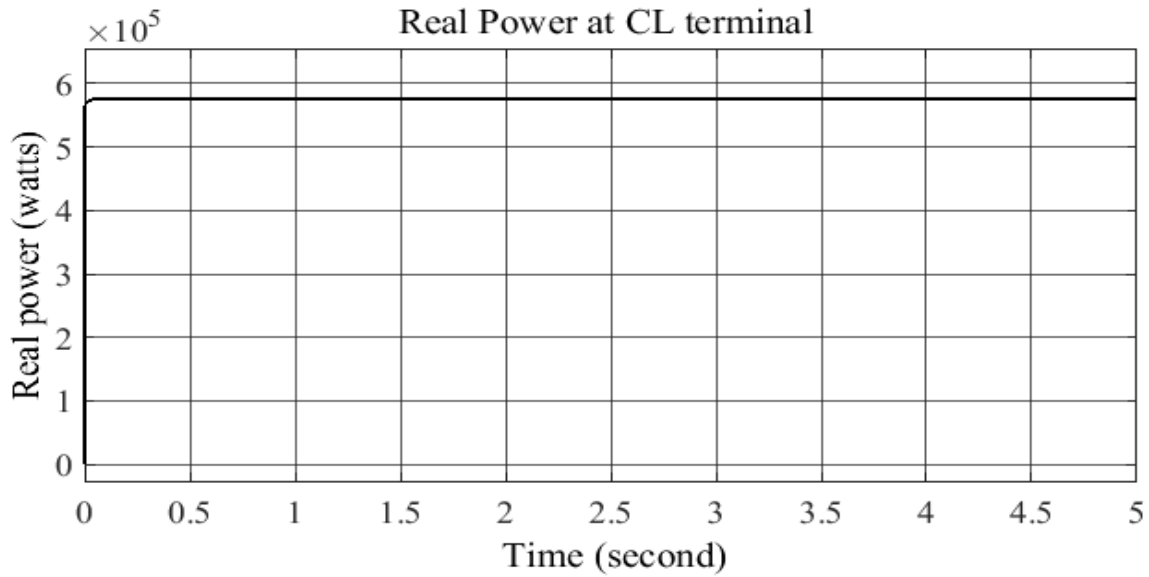

Fig. 21. Real power of CL load fulfilled by SPV generator.

### 3.4.2 Scenario-2

In this assumed case, solar irradiance to the system is  $1000 \text{ W/m}^2$ , cell temperature is  $30^\circ\text{C}$  and AC load (CL) of the system is less than the generated power by the SPV generator. So in this condition apart from de-rating of MPPT condition, the excess power generated in system is being transferred to the DC load (NCL) of the system. Balancing of real power of the system and frequency response at AC load terminal is shown in Fig. as:

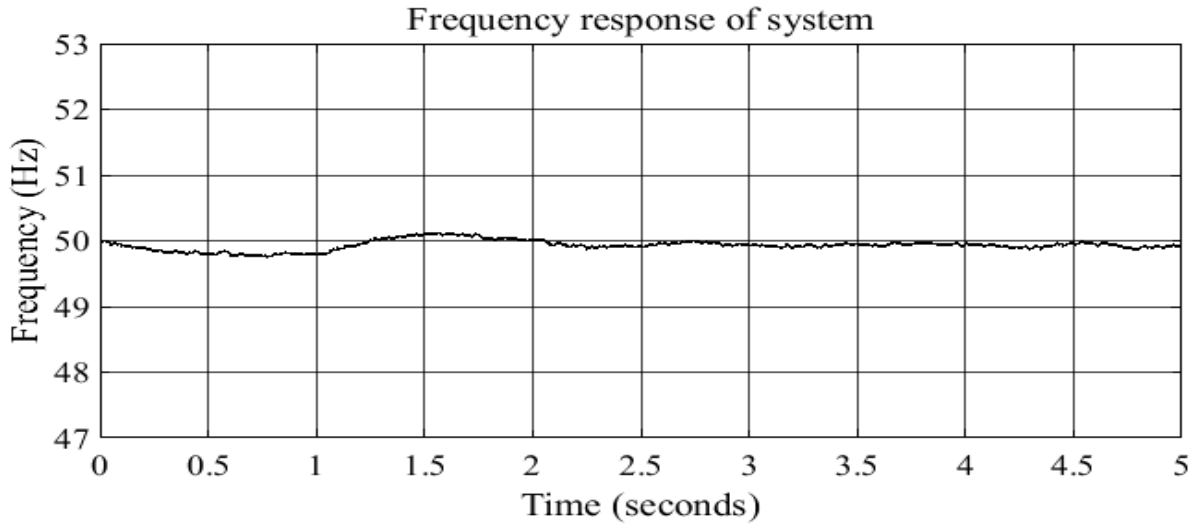

Fig. 22. Frequency response of the system.

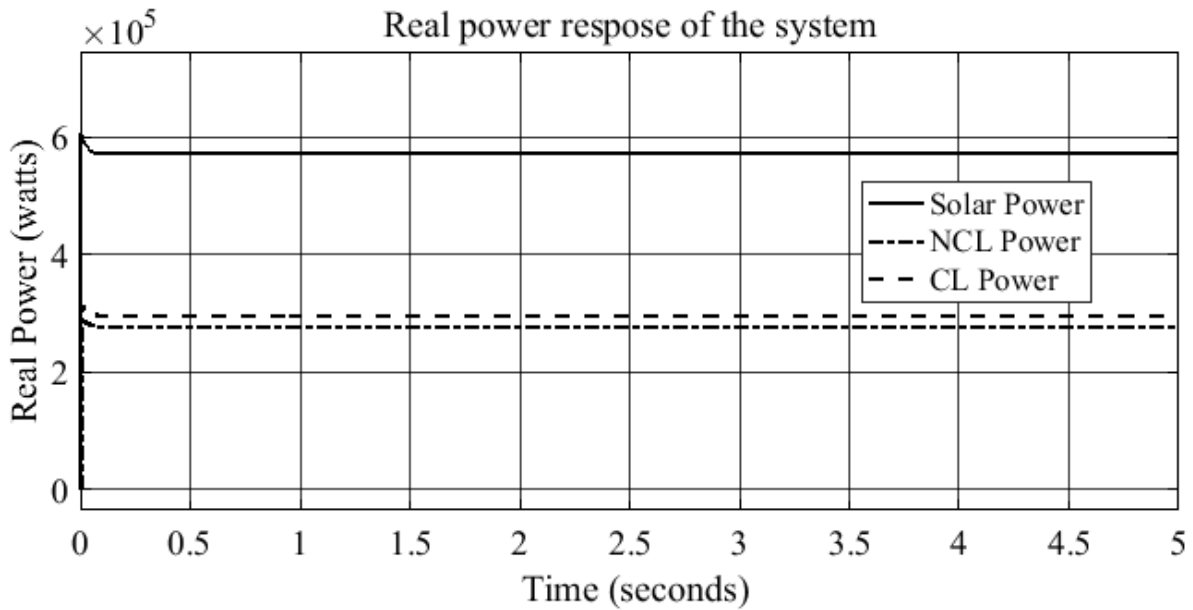

Fig. 23. Real power to CL and NCL fulfilled by SPV.

### 3.4.3 Scenario-3

In this presented scenario, input to the SPV generator like solar irradiance is  $500 \text{ W/m}^2$  is assumed at  $30^\circ\text{C}$  cell temperature. Additionally, AC loads (CLs) demand is higher than power generated by the SPV generator, so the remaining demand power is fulfilled by the DE and no

power is being transferred to DC load (NCL). Fig. 25 presents that, power of SPV generator is 300kW, Diesel power is 90kW and total CLs power is 390 kW, Real power and frequency response of the system is shown in Fig. as:

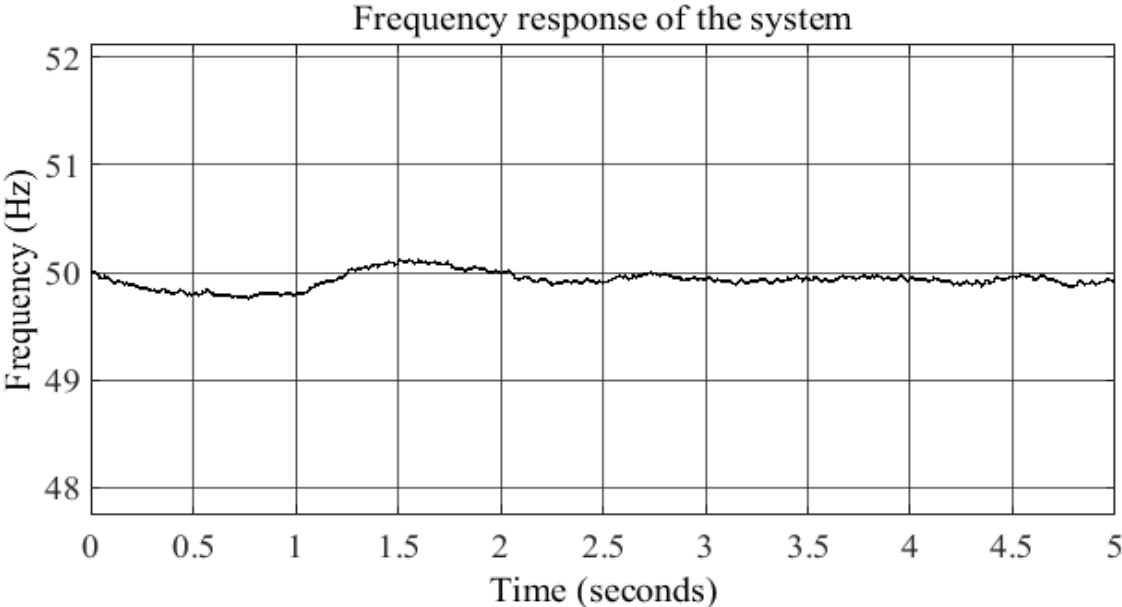

Fig. 24. Frequency response of the system at CL terminal

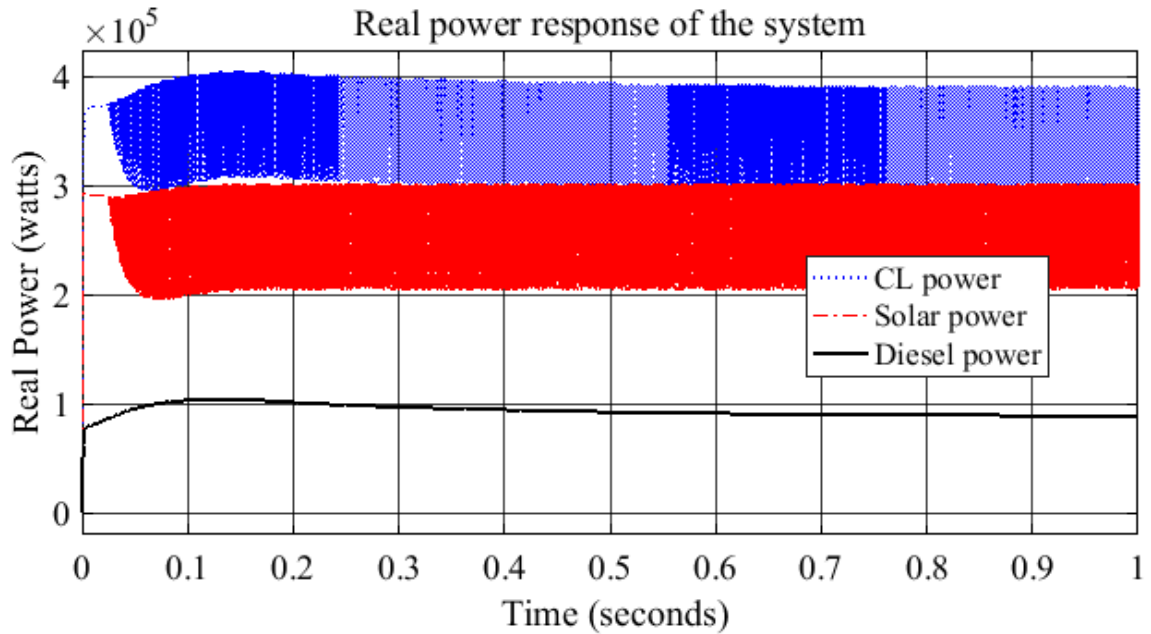

Fig. 25. Real power demand of CL fulfilled by SPV generator & DE.

#### 3.4.4 Scenario-4

In this assumed situation, there is no input to the SPV generator so the output of SPV generator is zero. In this condition, the considered constant AC loads (CLs) is being fulfilled by the DE only and no power is being transferred to the DC loads (NCLs). In Fig. 26, it is observed that initially the frequency becomes down to 48 Hz, it is due to the sudden loading to DE but it regain its nominal value through its feedback system within 2 sec of simulation time and becomes 50 Hz with 0.02 % of fluctuation. Demanded real power, fulfilled by DE and frequency of the system is presented as in Fig. 26 and Fig. 27

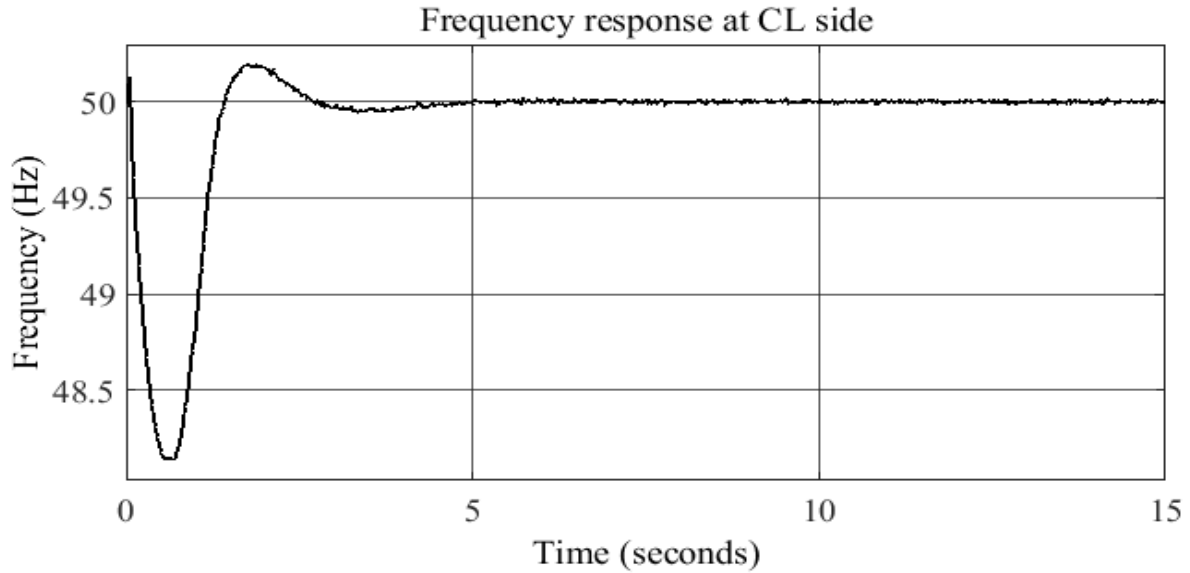

Fig. 26. Frequency response at CL fulfilled by DE.

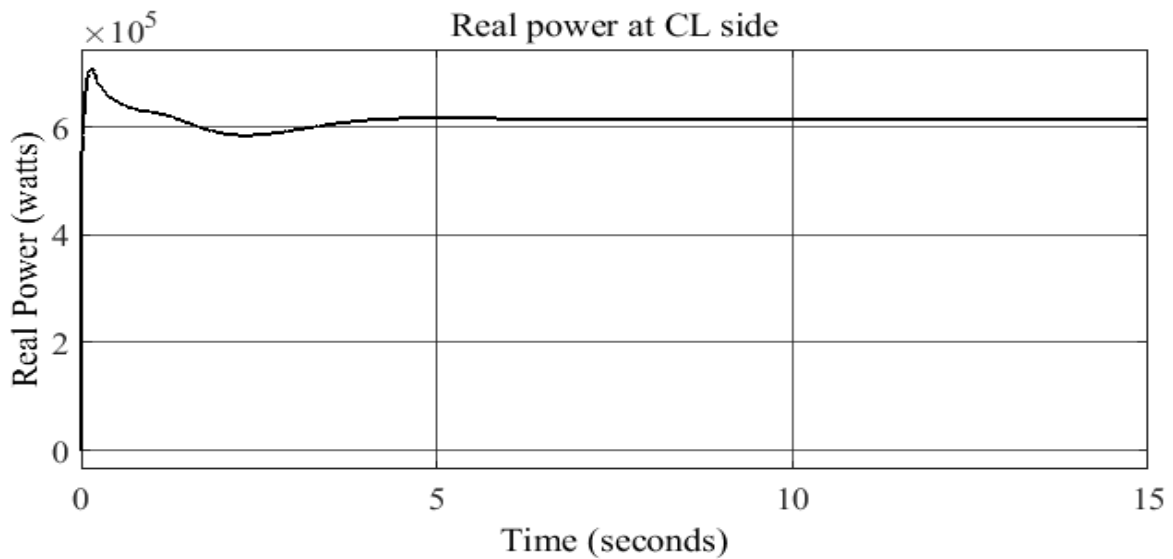

Fig. 27. Real power response of CL fulfilled by DE.

### 3.4.5 Scenario-5

This scenario is extended condition of scenario-4. In this situation the AC loads (CLs) of system is variable load. The frequency of the system shown in Fig. 28, is controlled near to 50 Hz, there is fluctuation about to 2% at the simulation time of 5<sup>th</sup> second. In Fig.29 there are spikes after each second of simulation, it is due to the change in AC load (switching of AC load). As there is

no SPV power available, all the CLs demand is fulfilled by the DE only. Real power of load fulfilled by DE and frequency of system is show in Fig. as:

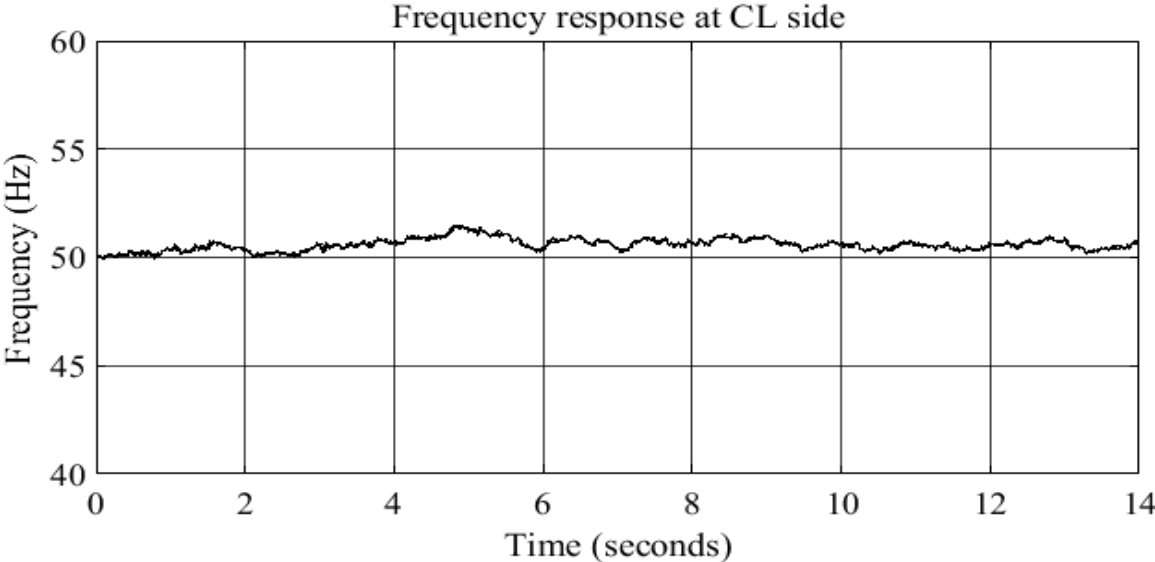

Fig. 28. Frequency response at variable CL terminal.

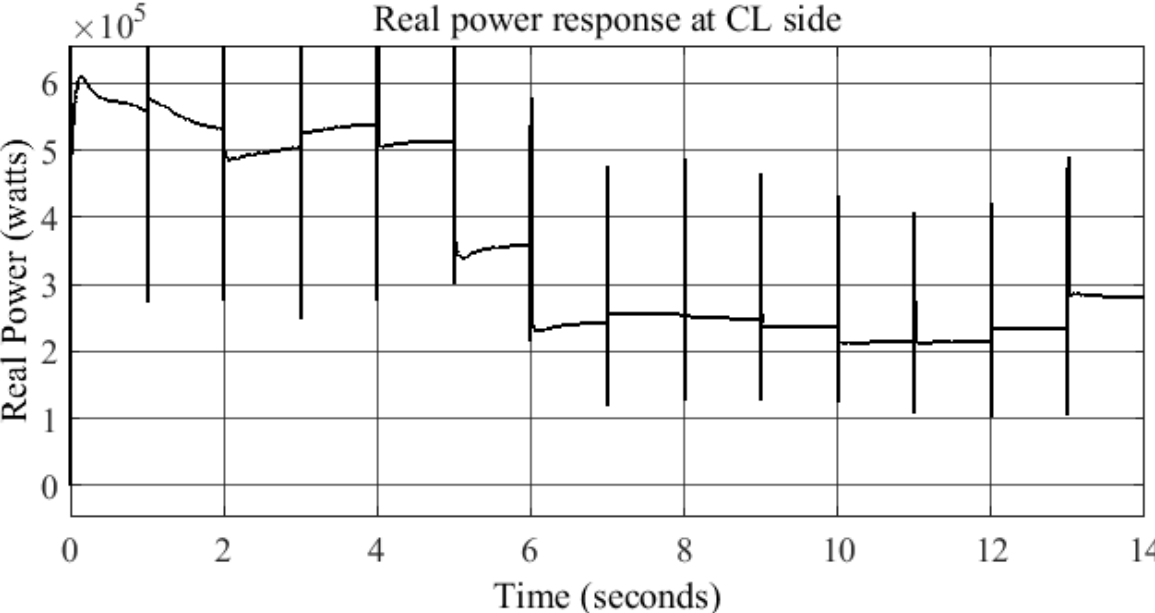

Fig. 29. Real power of variable CL fulfilled by DE.

### **3.5 CONCLUSION**

In this chapter, the practicality of a novel control scheme by utilizing SPV generator as a time variable source is verified. It is found that the frequency deviation and real power can be controlled by combining the fuzzy logic and artificial Neural Network mechanism, presented as ANFIS. The novel approach for controlling the power generated by SPV by an Adaptive Neuro Fuzzy Inference System based controller is proposed and found promising due to its learning capability resulting in automated decision for the flow of power to NCL according to scenario of power demand and generation. The result of the proposed system seems to be acceptable in all the considered situations.

## Chapter 4

### Conclusion and Future scope of work

---

#### 4.1 CONCLUSIONS

In this dissertation, the feasibility of the novel control scheme by using SPV generator as a time variable source is verified. In chapter 2, it is found that the frequency deviation and real power can be controlled on the basis of artificial neural network mechanism. The novel approach for controlling the power generated by SPV by an adaptive Neuro-PI controller is proposed. In chapter 3, it is found that the frequency deviation and real power can be controlled by combining the fuzzy logic and artificial Neural Network mechanism, presented as ANFIS. The novel approach for controlling the power generated by SPV by an Adaptive Neuro Fuzzy Inference System based controller is proposed. It is found promising due to its learning capability resulting in automated decision for the flow of power to NCL according to scenario of power demand and generation. The result of the proposed system seems to be acceptable in all the considered situations.

#### 4.2 FUTURE SCOPE OF WORK

The future scope of presented work are stated as-

- a) The presented research work is carried out considering a low voltage SPV generator and DE based hybrid microgrid catering AC loads and DC loads both as critical and non-critical loads. This work can be extended for the performance analysis of likely hybrid microgrid having AC and DC element to have better economic and controlled condition.
- b) The simulation of the presented work can be applied on practical situation to have a hybrid microgrid equipped with an efficient power managing system.

## List of Publications

---

1. Manish Kumar Yadav, P. Basak, “Real Power Control for Efficient Energy Management in Storage Free Diesel-SPV based Hybrid Microgrid”, in *Proc. International Conference on Energy Options for Tomorrow 2017, 17-19 April, 2017, The Neoutia University, Kolkata.*
2. Manish Kumar Yadav, Prasenjit Basak, “Adaptive neuro fuzzy controller for real power control of storage free hybrid microgrid”, *communicated to IET Generation, Transmission & Distribution*, Manuscript ID: (GTD-2017-1049) Manuscript Type: (Research Paper).

## References

---

- [1] Z. Zhao, P. Yang, J. M. Guerrero, Z. Xu, and T. C. Green, 'Multiple-time-scales hierarchical frequency stability control strategy of medium-voltage isolated microgrid', *IEEE Trans. Power Electron.*, vol. 31, no. 8, pp. 5974–5991, 2016.
- [2] J. Zhao, X. Lyu, Y. Fu, X. Hu, and F. Li, 'Coordinated Microgrid Frequency Regulation Based on DFIG Variable Coefficient Using Virtual Inertia and Primary Frequency Control', *IEEE Trans. Energy Convers.*, vol. 31, no. 3, pp. 833–845, 2016.
- [3] D. Wu, F. Tang, T. Dragicevic, J. C. Vasquez, and J. M. Guerrero, 'A Control Architecture to Coordinate Renewable Energy Sources and Energy Storage Systems in Islanded Microgrids', pp. 1–11, 2014.
- [4] N. R. Tummuru *et al.*, 'Energy Management of AC-DC Microgrid under Grid-connected and Islanded Modes', pp. 1–6, 2016.
- [5] X. S. Tang, X. Hu, N. N. Li, W. Deng, and G. W. Zhang, 'A Novel Frequency and Voltage Control Method for Islanded Microgrid Based on Multienergy Storages', *IEEE Trans. Smart Grid*, vol. 7, no. 1, pp. 410–419, 2016.
- [6] X. Sun, B. Liu, Y. Cai, H. Zhang, Y. Zhu, and B. Wang, 'Frequency-based power management for photovoltaic/battery/fuel cell-electrolyser stand-alone microgrid', *IET Power Electron.*, vol. 9, no. 13, pp. 2602–2610, 2016.
- [7] P. C. Sekhar and S. Mishra, 'Storage Free Smart Energy Management for Frequency Control in a Diesel-PV-Fuel Cell-Based Hybrid AC Microgrid', *IEEE Trans. Neural Networks Learn. Syst.*, vol. 27, no. 8, pp. 1657–1671, 2016.
- [8] P. C. Sekhar, S. Mishra, and R. Sharma, 'Data analytics based neuro-fuzzy controller for diesel-photovoltaic hybrid AC microgrid', no. November 2014, pp. 193–207, 2015.
- [9] W. A. Omran, M. Kazerani, and M. M. A. Salama, 'Investigation of methods for reduction of power fluctuations generated from large grid-connected photovoltaic systems', *IEEE Trans. Energy Convers.*, vol. 26, no. 1, pp. 318–327, 2011.

- [10] L. I. Minchala-Avila, L. Garza-Castanon, Y. Zhang, and H. J. A. Ferrer, ‘Optimal Energy Management for Stable Operation of an Islanded Microgrid’, *IEEE Trans. Ind. Informatics*, vol. 12, no. 4, pp. 1361–1370, 2016.
- [11] R. Majumder, S. Member, A. Ghosh, G. Ledwich, and S. Member, ‘Power Management and Power Flow Control With Back-to-Back Converters in a Utility Connected Microgrid’, vol. 25, no. 2, pp. 821–834, 2010.
- [12] J. A. P. Lopes, C. L. Moreira, and A. G. Madureira, ‘Defining control strategies for microgrids islanded operation’, *IEEE Trans. Power Syst.*, vol. 21, no. 2, pp. 916–924, 2006.
- [13] D. J. Lee and L. Wang, ‘Small-signal stability analysis of an autonomous hybrid renewable energy power generation/energy storage system part I: Time-domain simulations’, *IEEE Trans. Energy Convers.*, vol. 23, no. 1, pp. 311–320, 2008.
- [14] S. Kotra, S. Member, M. K. Mishra, and S. Member, ‘A Supervisory Power Management System for a Hybrid Microgrid with HESS’, vol. 46, no. c, pp. 1–10, 2017.
- [15] F. Katiraei and M. R. Iravani, ‘Power management strategies for a microgrid with multiple distributed generation units’, *IEEE Trans. Power Syst.*, vol. 21, no. 4, pp. 1821–1831, 2006.
- [16] N. Kakimoto, S. Takayama, H. Satoh, and K. Nakamura, ‘Power modulation of photovoltaic generator for frequency control of power system’, *IEEE Trans. Energy Convers.*, vol. 24, no. 4, pp. 943–949, 2009.
- [17] J. Jeon, J. Kim, H. Kim, S. Kim, C. Cho, and J. Kim, ‘Development of Hardware In-the-Loop Simulation System for Testing Operation and Control Functions of Microgrid’, vol. 25, no. 12, pp. 2919–2929, 2010.
- [18] Y. Han, P. Shen, X. Zhao, and J. M. Guerrero, ‘An Enhanced Power Sharing Scheme for Voltage Unbalance and Harmonics Compensation in an Islanded AC Microgrid’, *IEEE Trans. Energy Convers.*, vol. 31, no. 3, pp. 1037–1050, 2016.
- [19] A. H. Etemadi, E. J. Davison, L. Fellow, and R. Iravani, ‘A Generalized Decentralized Robust Control of Islanded Microgrids’, pp. 1–12, 2014.

- [20] A. Elmitwally and M. Rashed, 'Flexible operation strategy for an isolated PV-diesel microgrid without energy storage', *IEEE Trans. Energy Convers.*, vol. 26, no. 1, pp. 235–244, 2011.
- [21] M. Datta, T. Senjyu, A. Yona, T. Funabashi, and C. H. Kim, 'A frequency-control approach by photovoltaic generator in a PV-diesel hybrid power system', *IEEE Trans. Energy Convers.*, vol. 26, no. 2, pp. 559–571, 2011.
- [22] C. M. Colson, M. H. Nehrir, L. Fellow, and R. K. Sharma, 'Improving Sustainability of Hybrid Energy Systems Part II : Managing Multiple Objectives With a Multiagent System', vol. 5, no. 1, pp. 46–54, 2014.
- [23] C. M. Colson and M. H. Nehrir, 'Comprehensive Real-Time Microgrid Power', pp. 1–11, 2012.
- [24] H. Bevrani, M. R. Feizi, and S. Ataei, 'Robust Frequency Control in an Islanded Microgrid:  $H_\infty$  and  $\mu$ -Synthesis Approaches', *IEEE Trans. Smart Grid*, vol. 7, no. 2, pp. 706–717, 2016.
- [25] M. Bayat, K. Sheshyekani, M. Hamzeh, and A. Rezaadeh, 'Coordination of Distributed Energy Resources and Demand Response for Voltage and Frequency Support of MV Microgrids', *IEEE Trans. Power Syst.*, vol. 31, no. 2, pp. 1506–1516, 2016.
- [26] M. Ashabani, Y. A. I. Mohamed, and S. Member, 'New Family of Microgrid Control and Management Strategies in Smart Distribution Grids — Analysis , Comparison and Testing', pp. 1–13, 2014.
- [27] D. Sera, R. Teodorescu, and P. Rodriguez, 'PV panel model based on datasheet values', *IEEE Int. Symp. Ind. Electron.*, no. 4, pp. 2392–2396, 2007.
- [28] S. A. Rahman, R. K. Varma, and T. Vanderheide, 'Generalised model of a photovoltaic panel', no. July 2013, 2014.
- [29] P.W. Sauer, "Power System Dynamics and Stability", pp. 163. New Jersey, USA: Prentice

Hall, 1998.

- [30] Jang, J.-S. R., "ANFIS: Adaptive-Network-based Fuzzy Inference Systems," *IEEE Transactions on Systems, Man, and Cybernetics*, Vol. 23, No. 3, pp. 665-685, May 1993.
  - [31] Jang, J.-S. R. and C.-T. Sun, *Neuro-Fuzzy and Soft Computing: A Computational Approach to Learning and Machine Intelligence*, Prentice Hall, 1997.
-

## Appendix

---

A	1.732
D	0.012
f <sub>SYS</sub>	50 Hz
G <sub>NOM</sub>	1000 W/m <sup>2</sup>
H	5
I <sub>SC</sub>	6.14 A
I <sub>SC(STC)</sub>	6.14 A
k	1.38 * 10 <sup>-23</sup> J/K
K <sub>DG</sub>	0.00333
K <sub>V</sub>	-0.16
n	1.732
n <sub>P</sub>	160
N <sub>S</sub>	13
q	1.602*10 <sup>-19</sup> C
R <sub>S</sub>	0.47 Ω
R <sub>SH</sub>	1365 Ω
T <sub>DG</sub>	2 sec
T <sub>S</sub>	298 K
V <sub>OC</sub>	64.6 V
V <sub>OC(STC)</sub>	64.6 V

# Real Power Control of Storage Free Hybrid Microgrid

---

## ORIGINALITY REPORT

---

%**4**

SIMILARITY INDEX



%**2**

INTERNET SOURCES

%**4**

PUBLICATIONS

%

STUDENT PAPERS

---

## PRIMARY SOURCES

---

**1**

Shah Arifur Rahman, Rajiv K. Varma.  
"PSCAD/EMTDC model of a 3-phase grid  
connected photovoltaic solar system", 2011  
North American Power Symposium, 2011

Publication

<%**1**

---

**2**

Kakimoto, N., S. Takayama, H. Satoh, and K.  
Nakamura. "Power Modulation of Photovoltaic  
Generator for Frequency Control of Power  
System", IEEE Transactions on Energy  
Conversion, 2009.

Publication

<%**1**

---

**3**

Eghtedarpour, Navid, and Ebrahim Farjah.  
"Power Control and Management in a Hybrid  
AC/DC Microgrid", IEEE Transactions on Smart  
Grid, 2014.

Publication

<%**1**

---

**4**

Lee, Dong-Jing Wang, Li. "Small-signal stability  
analysis of an autonomous hybrid renewable  
energy power generation/energy sto", IEEE  
Transactions on Energy Conversion, March  
2008 Issue

<%**1**

5

Wei, Chih-Chiang. "Soft computing techniques in ensemble precipitation nowcast", Applied Soft Computing, 2013.

Publication

<% 1

6

ijrer.org

Internet Source

<% 1

7

Tang, Xisheng, Xiao Hu, Ningning Li, Wei Deng, and Guowei Zhang. "A Novel Frequency and Voltage Control Method for Islanded Microgrid Based on Multienergy Storages", IEEE Transactions on Smart Grid, 2015.

Publication

<% 1

8

file.scirp.org

Internet Source

<% 1

9

Nizamettin Aydin. "Data Mining Usage in Emboli Detection", 2007 ECSIS Symposium on Bio-inspired Learning and Intelligent Systems for Security (BLISS 2007), 08/2007

Publication

<% 1

10

Jin-Hong Jeon, , Jong-Yul Kim, Hak-Man Kim, Seul-Ki Kim, Changhee Cho, Jang-Mok Kim, Jong-Bo Ahn, and Kee-Young Nam. "Development of Hardware In-the-Loop Simulation System for Testing Operation and Control Functions of Microgrid", IEEE

<% 1

## Transactions on Power Electronics, 2010.

Publication

11

[docplayer.net](http://docplayer.net)

Internet Source

<% 1

12

Han, Yang, Pan Shen, Xin Zhao, and Josep M. Guerrero. "Control Strategies for Islanded Microgrid Using Enhanced Hierarchical Control Structure With Multiple Current-Loop Damping Schemes", IEEE Transactions on Smart Grid, 2015.

Publication

<% 1

13

Wang Zhuo. "An adaptive neuro-fuzzy inference system for engineering-vehicle shift decisions", International Journal of Heavy Vehicle Systems, 2002

Publication

<% 1

14

Raedani, Ronn, and Moin Hanif. "Design, testing and comparison of P&O, IC and VSSIR MPPT techniques", 2014 International Conference on Renewable Energy Research and Application (ICRERA), 2014.

Publication

<% 1

15

[www1.pacific.edu](http://www1.pacific.edu)

Internet Source

<% 1

16

Jayawardena, A.V., L.G. Meegahapola, S. Perera, and D.A. Robinson. "Dynamic characteristics of a hybrid microgrid with

<% 1

inverter and non- inverter interfaced renewable energy sources: A case study", 2012 IEEE International Conference on Power System Technology (POWERCON), 2012.

Publication

---

17

Girija, R., and R. Arivalahan. "Decentralized control of interlinking converter by interfacing AC and DC micro grids", 2014 IEEE National Conference on Emerging Trends In New & Renewable Energy Sources And Energy Management (NCET NRES EM), 2014.

Publication

---

18

G. Mallesham. "Maiden application of Ziegler-Nichols method to AGC of Distributed Generation System", 2009 IEEE/PES Power Systems Conference and Exposition, 03/2009

Publication

---

19

Sadeghi, Mahmood, and Mohsen Kalantar. "Multi types DG expansion dynamic planning in distribution system under stochastic conditions using Covariance Matrix Adaptation Evolutionary Strategy and Monte-Carlo simulation", Energy Conversion and Management, 2014.

Publication

---

20

Tsung-Jen Lin. "Stability and Performance of an Autonomous Hybrid Wind-PV-Battery

<% 1

<% 1

<% 1

<% 1

# System", 2007 International Conference on Intelligent Systems Applications to Power Systems, 11/2007

Publication

---

---

EXCLUDE QUOTES    OFF

EXCLUDE MATCHES    < 7 WORDS

EXCLUDE  
BIBLIOGRAPHY    ON