

**To Study and Implement Iris Recognition
to Give Firsthand Experience to An Alternative Approach to
Government of India for 'AADHAR CARD'
to be Implemented by
Unique Identification Authority of India (UIDAI)**

*Thesis submitted in partial fulfillment of the requirements for the award of
degree of*

**Master of Engineering
in
ELECTRONICS AND COMMUNICATION ENGINEERING**

Submitted By

Arun

(Roll No. 801061005)

Under the supervision of:

Dr. Hardeep Singh

Assistant Professor

(Electronics & Communication Engineering Department)



**ELECTRONICS AND COMMUNICATION ENGINEERING DEPARTMENT
THAPAR UNIVERSITY
(Established under the section 3 of UGC Act, 1956)
PATIALA – 147004, INDIA
JUNE-2012**

DECLARATION

I, Arun, hereby certify that the work which is being presented in this thesis entitled "To Study and Implement Iris Recognition to Give Firsthand Experience to An Alternative Approach to Government of India for 'AADHAR CARD' to be Implemented by Unique Identification Authority of India(UIDAI)" by me in partial fulfillment of the requirements for the award of degree of Master of Engineering in Electronics and Communication Engineering from Thapar University (Deemed University), Patiala, is an authentic record of my own work carried out under the supervision of "Dr. Hardeep Singh".

The matter presented in this thesis has not been submitted in any other University / Institute for the award of any other degree.

Date: 19/06/2012

Arun

Roll No: 801061005

It is certified that the above statement made by the student is correct to the best of my knowledge and belief.

Date:

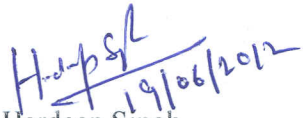
19/06/2012
Dr. Hardeep Singh
Assistant Professor
ECED

Countersigned by:

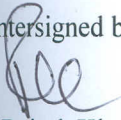
(Dr. Rajesh Khanna)
Professor and Head ECED
Thapar University, Patiala
Date:

(Dr. S.K. Mohapatra)
Dean of Academic Affairs
Thapar University, Patiala
Date:

ACKNOWLEDGEMENT

I would like to give special thanks to my guide **Dr. Hardeep Singh** Assistant Professor **ECED**, Thapar University, Patiala, for his advice, kind assistance, and invaluable guidance. It has been a great honor to work under him.

I am also thankful to **Dr. Rajesh Khanna**, Prof. & Head, Electronics and communication Engineering Department, for providing us with adequate infrastructure in carrying the work.

I am also thankful to **Dr. Kulbir Singh** , P.G. Coordinator, Electronics and communication Engineering Department for the motivation and inspiration that triggered me for the report work.

I would also like to thank all the faculty members of ECED for their intellectual support and also special thanks to my friends who constantly encouraged me to complete this work. I am also thankful to the authors whose work I have consulted and quoted in this work.

ARUN

Roll no. 801061005

Abstract

A biometric system provides automatic identification of an individual based on a unique feature or characteristic possessed by the individual. Iris recognition is regarded as the most reliable and accurate biometric identification system available. Most commercial iris recognition systems use patented algorithms developed by Daugman, and these algorithms are able to produce perfect recognition rates. However, published results have usually been produced under favourable conditions, and there have been no independent trials of the technology.

The objective of present work is a self-memorandum which revolves around “To Study and Implement Iris Recognition to Give First-hand Experience to An Alternative Approach to Government of India for ‘AADHAR CARD’ to be Implemented by Unique Identification Authority of India (UIDAI)”. The alternative approach is based on the premise that as existing work are patented and need to search the iris boundaries over large parameter space exhaustively, which takes more computational time. Moreover, they may result in circle detection failure, because some chosen threshold values used for edge detection cause critical edge points being removed. In this work, we implement simple method for iris recognition in iris images to implement in day to day life, using MATLAB®. The emphasis will be only on the software for performing recognition, and not hardware for capturing an eye image.

Every biometric system has mainly two modules, one is ‘verification’ and the other is ‘recognition’. The verification part is involved in matching the test/real-time input with current database while recognition involves presenting the output from the database to which the test/real-time input. The work presented in this thesis involved developing an ‘open-source’ iris verification system.

Gibson always stressed that one must understand the nature of the environment before one can understand the nature of visual processing. However, his comments have gone largely unheeded in the mainstream of vision research. There seems to be a belief that images from the natural environment vary so widely from scene to scene that a general description would be impossible. Thus an analysis of such images is presumed to give little insight into visual function. As our goal is to study and implement the iris recognition technology with an alternative approach. Our

alternative approach implemented the algorithm in MATLAB[®] code, is based on two assumed premises:

1. The intensity of brightness of sclera is greater than iris, whose intensity if brightness is in turn greater than pupil.
2. Iris and pupil are concentric.

The iris recognition system consists of an automatic segmentation system that is based on the Hough transform, and is able to localise the circular iris and pupil region, occluding eyelids and eyelashes, and reflections. The extracted iris region was then normalised into a rectangular block with constant dimensions to account for imaging inconsistencies. Finally, the phase data from 2D Log-Gabor filters was extracted and quantised to four levels to encode the unique pattern of the iris into a bit-wise biometric template. The Hamming distance was employed for classification of iris templates, and two templates were found to match if a test of statistical independence was failed. Iris verification is shown to be a reliable and accurate biometric technology.

Contents

DECLARATION	i
ACKNOWLEDGEMENT	ii
ABSTRACT	iii
Contents	v
List of Figure	vii
List of Table	xi
List of Abbreviation	xii
List of Symbols	xiii
1. Introduction	1
1.1 Biometric Technology	2
1.2 Biometric Technology from Cultural Viewpoint	8
1.3 The Human Iris	8
1.4 Iris Recognition.....	9
1.5 Biometrics Technology in India.....	10
2. Literature Survey	11
3. Research Question, Motivation and Justification	18
3.1 Research Question.....	18
3.2 A Gap Analysis Between The Existing Work And Targeted Work	18
3.2.1 Implementation Perspectives In India.....	19
3.2.2 Ongoing Implementations In The World	30
3.3 Gap Analysis From Technological Perspective	31
3.3.1 Segmentation	32
3.3.2 Normalisation	36
3.3.3 Feature Encoding	39
3.3.4 Matching Algorithms	43
4. Design and Implementation of Research Problem	48
4.1 MATLAB Toolbox Discription	48

4.2	Image Processing Toolbox Description.....	48
4.3	The implementation of present work.....	49
5.	Experimental Results	60
5.1	Pupil Detection Module.....	62
5.2	Iris Detection Module.....	67
5.3	Eyelid detection Module.....	70
5.4	Normalisation module	71
5.5	Feature encoding module.....	73
5.6	Results and Output in running manner	74
6.	Conclusion and Future Research	80
	References	82

List of Figures

Figure 1.1	Biometric System.....	1
Figure 1.2	Verification in biometrics.....	4
Figure 1.3	Identification in biometrics.....	5
Figure 1.4	Working of biometric system.....	6
Figure 3.1	Basic Technological Components of Iris Recognition Technology.....	31
Figure 3.2	Technological Perspectives of Segmentation Module.....	32
Figure 3.3	Technological Perspectives in Normalisation Module.....	37
Figure 3.4	Technological Perspectives in Normalisation Module.....	39
Figure 3.5	Technological Perspectives in Normalisation Module.....	43
Figure 4.1	Flowchart of implemented algorithm.....	50
Figure 4.2	Loaded sample image of iris.....	51
Figure 4.3	Pupil detection module.....	51
Figure 4.4	Isolated portion of pupil from sample image.....	52
Figure 4.5	Boundary drawn on pupil from sample image.....	53
Figure 4.6	Iris detection module.....	53
Figure 4.7	Boundary drawn on iris from sample image.....	54
Figure 4.8	Eyelids detection module.....	55
Figure 4.9	Boundary drawn on pupil and iris from sample image.....	55
Figure 4.10	Normalisation module.....	56
Figure 4.11	Normalised iris and mask of sample image.....	57

Figure 4.12	Feature encoding module.....	57
Figure 4.13	Quantisation process employed in template generating module.....	58
Figure 4.14	Encoded template of sample image.....	58
Figure 4.15	Template matching module.....	59
Figure 5.1	Sample images available on IIT Delhi website.....	61
Figure 5.2	GUI of image loading step.....	61
Figure 5.3	Pupil detection (sample image 1).....	62
Figure 5.4	Pupil detection (sample image 2).....	62
Figure 5.5	Pupil detection (sample image 3).....	63
Figure 5.6	Pupil detection (sample image 4).....	63
Figure 5.7	Pupil detection (sample image 5).....	64
Figure 5.8	Pupil detection (sample image 6).....	64
Figure 5.9	Pupil detection (sample image 7).....	65
Figure 5.10	Pupil detection (sample image 8).....	65
Figure 5.11	Pupil detection (sample image 9).....	66
Figure 5.12	Error occurred in pupil detection for sample image 6,7,8,9.....	66
Figure 5.13	Iris detection (sample image 1).....	67
Figure 5.14	Iris detection (sample image 2).....	67
Figure 5.15	Iris detection (sample image 3).....	68
Figure 5.16	Iris detection (sample image 4).....	68
Figure 5.17	Iris detection (sample image 4).....	69

Figure 5.18	Eyelids detection (sample image 1).....	69
Figure 5.19	Eyelids detection (sample image 2).....	70
Figure 5.20	Eyelids detection (sample image 3).....	70
Figure 5.21	Eyelids detection (sample image 4).....	71
Figure 5.22	Eyelids detection (sample image 5).....	71
Figure 5.23	Normalised iris and normalised mask (sample image 1).....	72
Figure 5.24	Normalised iris and normalised mask (sample image 2).....	72
Figure 5.25	Normalised iris and normalised mask (sample image 3).....	72
Figure 5.26	Normalised iris and normalised mask (sample image 4).....	72
Figure 5.27	Normalised iris and normalised mask (sample image 5).....	73
Figure 5.28	Encoded template of iris region (sample image 1).....	73
Figure 5.29	Encoded template of iris region (sample image 2).....	73
Figure 5.30	Encoded template of iris region (sample image 3).....	73
Figure 5.31	Encoded template of iris region (sample image 4).....	73
Figure 5.32	Encoded template of iris region (sample image 5).....	73
Figure 5.33	Loaded view of sample image.....	74
Figure 5.34	Pupil detection.....	75
Figure 5.35	Iris detection.....	75
Figure 5.36	Eyelid detection.....	76
Figure 5.37	Working of normalisation module.....	76
Figure 5.38	Working of template encoding module.....	76

Figure 5.39	Working of matching module (selecting template 'a').....	77
Figure 5.40	Working of matching module (again selecting template 'a').....	77
Figure 5.41	Working of matching module (giving 'Match Found' as result).....	78
Figure 5.42	Working of matching module (again selecting template 'b').....	78
Figure 5.43	Working of matching module (giving ' No Match Found' as result).....	79

List of Table

Table 1 : Comparison of available biometric systems.....	46
--	----

List of Abbreviations

FNR	False non-match rate
FMR	False match rate
ROC	Receiver operating characteristics
EER	Equal error rate
UIDAI	Unique Identification -Authority of India
WED	Weighted Euclidean distance
IIT	Indian Institute of Technology
PoC	Proof-of-Concept Study
FTE	Failure to enroll rate
RFPIR	False positive identification rate
FNIR	False negative identification rate
CIDR	Central information data repository
ABISs	Automatic biometric identification systems
FAR	False acceptance rate
FRR	Failure to register rate
DCAC	Discrete circular active contour
ROI	Regions of interest
FFT	Fast fourier transform
DCT	Discrete cosine transform

List of Symbols

θ	Angle of rotation relative to the x-axis.
G_i	External force
v_i	Position of vertex i
(r, θ)	Polar coordinates where r is on the interval $[0,1]$ and θ is angle $[0,2\pi]$
$I(x,y)$	Iris region image
(x,y)	Original Cartesian coordinates
$(u(x,y), v(x,y))$	Mapping function to transform the original coordinates
S	Scaling factor
$R(\phi)$	Matrix representing rotation by ϕ
(x_o, y_o)	Position in the image
(α, β)	Effective width and length
(u_o, v_o)	Modulation with
$h_{\{Re, Im\}}$	Complex valued bit whose real and imaginary components are dependent on the sign of the 2D integral
$I(\rho, \phi)$	Raw iris image in a dimensionless polar coordinate system
f_o	Centre frequency
σ	Bandwidth of the filter
$\theta(x)$	Smoothing function
σ	Standard deviation of the Gaussian
ρ	Radial distance of a point from the centre of the filter
p_1 and p_2	Two images of size $n \times m$

Introduction

1.1 Biometric Technology

Biometric is general term used alternatively to describe a characteristic or a process. As a characteristic it is a measureable biological (anatomical and physiological) and behavioural characteristic that can be used for automated recognition. As a process it encompasses automated methods of recognizing an individual based on measureable biological (anatomical and physiological) and behavioural characteristics. A biometric system provides automatic recognition of an individual based on same sort of unique features or characteristic possessed by the individual.

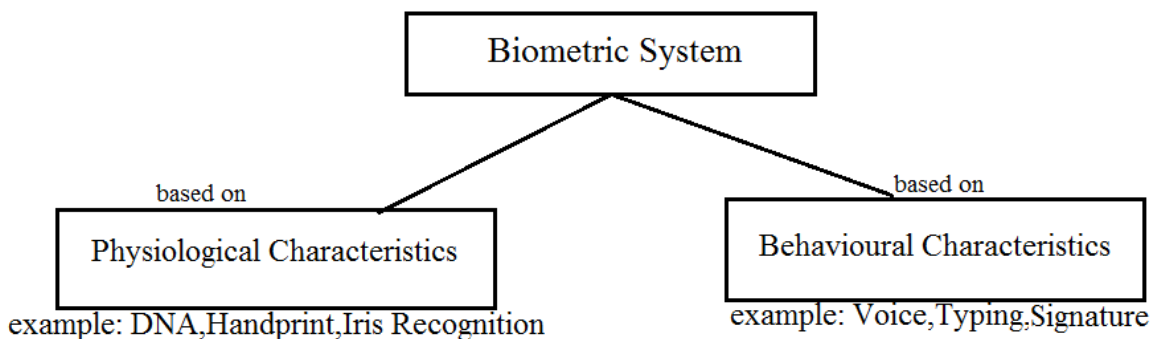

Figure 1.1 : Biometric System

Biometric recognition, or biometrics, refers to the automatic identification of a person based on his/her anatomical (e.g., fingerprint, iris) or behavioral (e.g., signature) characteristics or traits. This method of identification offers several advantages over traditional methods involving ID cards (tokens) or PIN numbers (passwords) for various reasons: (i) the person to be identified is required to be physically present at the point-of-identification; (ii) identification based on biometric techniques obviates the need to remember a password or carry a token. With the increased integration of computers and Internet into our everyday lives, it is necessary to protect sensitive and personal data. By replacing PINs (or using biometrics in addition to PINs), biometric techniques can potentially prevent unauthorized access to ATMs, cellular phones,

laptops, and computer networks. Unlike biometric traits, PINs or passwords may be forgotten, and credentials like passports and driver's licenses may be forged, stolen, or lost. As a result, biometric systems are being deployed to enhance security and reduce financial fraud. Various biometric traits are being used for real-time recognition, the most popular being face, iris and fingerprint. However, there are biometric systems that are based on retinal scan, voice, signature and hand geometry. In some applications, more than one biometric trait is used to attain higher security and to handle failure to enroll situations for some users. Such systems are called multimodal biometric systems [1].

A biometric system is essentially a pattern recognition system which recognizes a user by determining the authenticity of a specific anatomical or behavioral characteristic possessed by the user. Several important issues must be considered in designing a practical biometric system. First, a user must be enrolled in the system so that his biometric template or reference can be captured. This template is securely stored in a central database or a smart card issued to the user. The template is used for matching when an individual needs to be identified. Depending on the context, a biometric system can operate either in a verification (authentication) or an identification mode.

Because biometrics-based authentication offers several advantages over other authentication methods, there has been a significant surge in the use of biometrics for user authentication in recent years. It is important that such biometrics-based authentication systems be designed to withstand attacks when employed in security-critical applications, especially in unattended remote applications such as e-commerce [2].

Questions related to the identity of individuals such as “Is this the person who he or she claims to be?,” “Has this applicant been here before?,” “Should this individual be given access to our system?” are asked millions of times every day by organizations in financial services, health care, e-commerce, telecommunication, and government. In fact, identity fraud in welfare disbursements, credit card transactions, cellular phone calls, and ATM withdrawals totals over \$6 billion each year [3]. For this reason, more and more organizations are looking to automated identity authentication systems to improve customer satisfaction and operating efficiency as well as to save critical resources. Furthermore, as people become more connected electronically, the

ability to achieve a highly accurate automatic personal identification system is substantially more critical [4].

Evaluating the performance of a biometric identification system is a challenging research topic. The overall performance of a biometric system is assessed in terms of its accuracy, speed, and storage. Several other factors, like cost and ease-of-use, also affect efficacy. Biometric systems are not perfect, and will sometimes mistakenly accept an impostor as a valid individual (a false match) or conversely, reject a valid individual (a false nonmatch). The probability of committing these two types of errors are termed false nonmatch rate (FNR) and false match rate (FMR); the magnitudes of these errors depend upon how liberally or conservatively the biometric system operates. the trade-off between a system's FMR and FNR at different operating points; it's called the "Receiver Operating Characteristics (ROC)" and is a comprehensive measure of the system accuracy in a given test environment. High-security access applications, where concern about break-in is great, operate at a small FMR [5]. Forensic applications, where the desire to catch a criminal outweighs the inconvenience of examining a large number of falsely accused individuals, operate their matcher at a high FMR. Civilian applications attempt to operate their matchers at the operating points with both a low FNR and a low FMR. The error rate of the system at an operating point where

FMR equals FNR is called the equal error rate (EER) which may often be used as a terse descriptor of system accuracy. Accuracy performance of a biometrics system is considered acceptable if the risks (benefits) associated with the errors in the decision-making at a given operating point on ROC for the given test environment are acceptable. Similarly, accuracy of a biometrics-based identification is unacceptable/poor if the risks (benefits) associated with errors related to any operating point on the ROC for a given test environment are unacceptable (insufficient). The size of a template, the number of templates stored per individual, and the availability of compression mechanisms determine the storage required per user. When template sizes are large and the templates are stored in a central database, network bandwidth may become a system bottleneck for identification. A typical smartcard may only hold a few kilobytes of information (for instance, 8K) and in systems using smartcards to distribute the template storage, template size becomes an important design issue. The time required by a biometric system to make an identification decision is critical to many applications. For a typical

access-control application, the system needs to make an authentication decision in real-time. In an ATM application, for instance, it is desirable to accomplish the authentication within about one second. For forensic applications, however, the time requirements may not be very stringent. All other factors remaining identical, the widespread use of biometrics will be stimulated by its adoption in the consumer market. The single most important factor affecting this realization is the cost of the biometrics systems including the sensors and related infrastructure. Some sensors, such as microphones, are already very inexpensive, while others, such as CCD cameras, are now becoming standard peripherals in a personal computing environment. With the recent advances in solid-state technology, fingerprint sensors will become sufficiently inexpensive in the next few years. Storage requirements of the biometric templates and processing requirements for matching are among the two major considerations towards the infrastructure cost.

A biometric system generally involves three modules as :

- Recognition
- Verification
- Identification

Recognition is used in the description of required or relevant data from input biometric data for example face recognition, iris recognition which relates to their fundamental function.

Verification (Am I who I claim I am?) involves confirming or denying a person's claimed identity [1]. Verification in biometric systems involves the tasks where the biometric system attempts to confirm an individual's claimed identity by comparing a submitted sample to one or more previously enrolled templates.



Figure 1.2 : Verification in biometrics

In identification, the system has to recognize a person (Who am I?) from a list of N users in the template database. Identification is a more challenging problem because it involves 1:N matching compared to 1:1 matching for verification. Identification module involves the tasks where the biometric system searches a database for a reference matching a submitted sample. A biometric data is collected and compared to all the templates in a database. Closed set identification involves where person is known to exist in database. Open set identification involves where person is not guaranteed to exist in database.

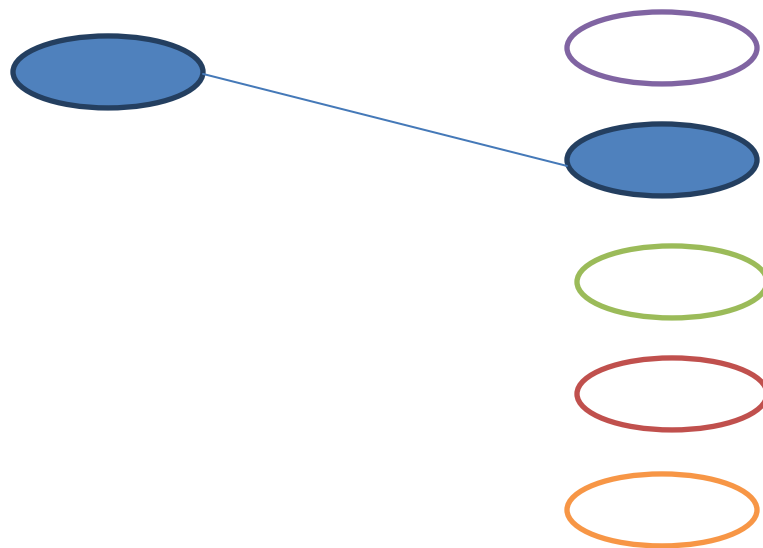

Figure 1.3 : Identification in biometrics

Biometric system work by first computing a sample of feature, such as recording a digital sound signal for voice recognition, or taking a colour image for face recognition. The sample is then transformed using same sort of mathematical function into a biometric template. The biometric template will provide a normalized and efficient representation of the feature, which can then be objectively compared with order to determine the identity.

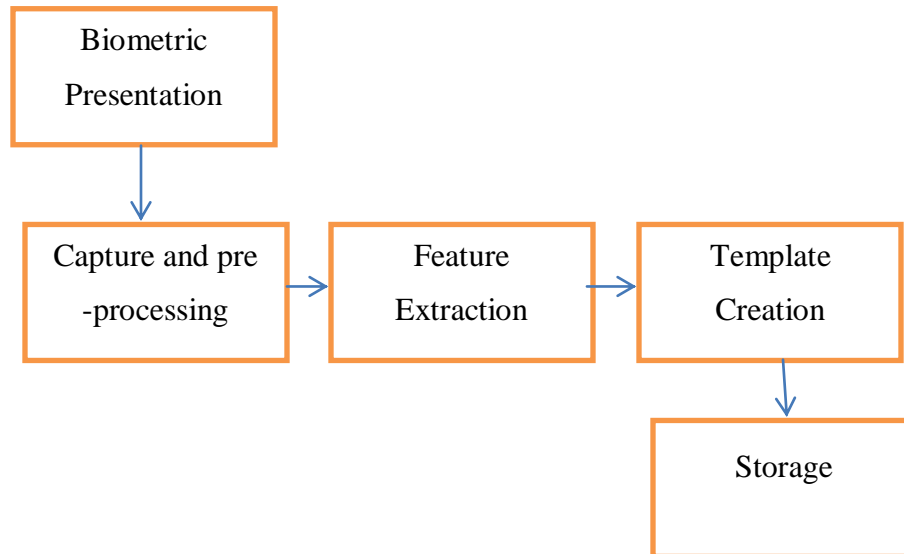

Figure 1.4 : Working of biometric system

Since there are many biometric systems which can be employed but the factors on which implementation depends inter alia are :

- Location
- Security Risk
- Task (Identification or Verification)
- Expected number of users
- Existing data
- User circumstances

A typical biometric system operates in four modules.

Sensor module: Raw biometric data of an individual is acquired through suitable biometric reader or scanner. The sensor module defines the interaction of the human with the system and is therefore pivotal to the performance of the biometric system.

A good biometric system is characterised by the use of a feature that is; highly unique-so that the chance of any two people having the same characteristic will be minimal, stable – so that the feature does not change over time, and be easily captured – in order to provide convenience to the user, and prevent misrepresentation of the feature [6].

Quality assessment and feature extraction module: The quality of the biometric data acquired by the sensor is first assessed in order to determine its suitability for feature extraction. Biometric data with inadequate quality is simply rejected and is reacquired. Sometimes, the quality assessment module may not be present and acquired data is subject to image preprocessing algorithm in order to improve its quality. The pre-processed data is then subject to feature extraction depending upon the type of biometric [7]. During enrollment, the extracted feature set is stored in the database which is commonly referred to as "template", representing the identity of an individual.

Matching module: The identity of an individual is verified by comparing the template to the input (query) biometric data of an individual. The match score determines the amount of similarity (similarity score) or distance (distance score) between the feature set of enrolled template and the query data [8].

Decision making module: The decision as to verify a claimed identity or to provide a ranking of the enrolled identities in order to identify an individual is made in this module. Usually, the match score is compared against the "threshold" (determined through empirical evidence) to determine the authenticity of an individual. The threshold, thr , is the point at which it becomes reasonably certain that a biometric sample matches a particular template [9]. The match score of the input data is required to be above the threshold for "similarity score" and below the threshold for "distance score" for the successful verification of an identity.

Biometric analysis for identity verification is becoming a widespread reality. Such implementations necessitate large-scale capture and storage of biometric data, which raises serious issues in terms of data privacy and (if such data is compromised) identity theft. These problems stem from the essential permanence of biometric data, which (unlike secret passwords or physical tokens) cannot be refreshed or reissued if compromised. Biometric-hash framework prescribes the integration of external (password or token-derived) randomness with user-specific biometrics, resulting in bitstring outputs with security characteristics (i.e., noninvertibility) comparable to cryptographic ciphers or hashes. The resultant BioHashes are hence cancellable, i.e., straightforwardly revoked and reissued (via refreshed password or reissued token) if compromised [10]. The variability in the distortion parameters provides the cancellable nature of the scheme [11]. Some of the proposed techniques operate using their own recognition engines, take the advantage of the advancement of the well-established biometric research for their recognition front-end to conduct recognition [12]. Iris recognition is an automated method of biometric identification that uses mathematical pattern-

recognition techniques on images of the iris of an individual's eyes, whose complex random patterns are unique and can be seen from some distance [13].

1.2 Biometric Technology from Cultural Viewpoint

The 2002 film *Minority Report* features extensive use of casual Iris/Retina scanning techniques for both personal Identification and Point Of Sale transaction purposes. The main character changes his official Identity by having his eyes transplanted, and later accesses a security system using one of the removed eyes.

The movie “*Gattaca*” portrays a society in which there are two classes of people: those genetically engineered to be superior (termed “Valid”) and the inferior natural humans (“Invalid”). People considered “Valid” have greater privileges, and access to areas restricted to such persons is controlled by automated biometric scanners similar in appearance to fingerprint scanners, but which prick the finger and sample DNA from the resulting blood droplet

The television program “*MythBusters*” attempted to break into a commercial security door equipped with fingerprint authentication as well as a personal laptop so equipped. While the laptop's system proved more difficult to bypass, the advanced commercial security door with “live” sensing was fooled with a printed scan of a fingerprint after it had been licked, as well as by a photocopy of a fingerprint.

In *Demolition Man* the character Simon Phoenix cuts out a living victim's eye in order to open a locked door which is fitted with iris scanning. A similar plot element was used in *Angels & Demons* (2009) when an assassin gains access to a top secret CERN facility using a physicist's eye. However, both of these examples are misleading to the audience since the methods depicted for enucleation (removal of an eye) from a corpse would not be a viable way to defeat such a system.

1.3 The Human Iris

The iris is a thin circular diaphragm, which lies between the cornea and the lens of the human eye. The iris is perforated close to its centre by a circular aperture known as the pupil. The function of the iris is to control the amount of light entering through the pupil, and this is done by the sphincter and

the dilator muscles, which adjust the size of the pupil. The average diameter of the iris is 12 mm, and the pupil size can vary from 10% to 80% of the iris diameter [14].

The iris consists of a number of layers, the lowest is the epithelium layer, which contains dense pigmentation cells. The stromal layer lies above the epithelium layer, and contains blood vessels, pigment cells and the two iris muscles. The density of stromal pigmentation determines the colour of the iris. The externally visible surface of the multi-layered iris contains two zones, which often differ in colour. An outer ciliary zone and an inner pupillary zone, and these two zones are divided by the collarette – which appears as a zigzag pattern.

Formation of the iris begins during the third month of embryonic life. The unique pattern on the surface of the iris is formed during the first year of life, and pigmentation of the stroma takes place for the first few years. Formation of the unique patterns of the iris is random and not related to any genetic factors [14]. The only characteristic that is dependent on genetics is the pigmentation of the iris, which determines its colour. Due to the epigenetic nature of iris patterns, the two eyes of an individual contain completely independent iris patterns, and identical twins possess uncorrelated iris patterns. For further details on the anatomy of the human eye consult the book by Wolff [14].

1.4 Iris Recognition

The iris is an externally visible, yet protected organ whose unique epigenetic pattern remains stable throughout adult life. These characteristics make it very attractive for use as a biometric for identifying individuals. Image processing techniques can be employed to extract the unique iris pattern from a digitised image of the eye, and encode it into a biometric template, which can be stored in a database. This biometric template contains an objective mathematical representation of the unique information stored in the iris, and allows comparisons to be made between templates. When a subject wishes to be identified by an iris recognition system, their eye is first photographed, and then a template created for their iris region. This template is then compared with the other templates stored in a database until either a matching template is found and the subject is identified, or no match is found and the subject remains unidentified.

John Daugman, Cambridge University researcher implanted a working automated iris recognition system. The Daugman system is patented[15] [16] and the rights are now owned by the company Iridian Technologies. Even though Daugman system is the most successful and most well known, many other systems have been developed. Compared with other biometric technologies, such as face,

speech and finger recognition, iris recognition can easily be considered as the most reliable form of biometric technology.

1.5 Biometrics Technology in India

India is currently undertaking an ambitious mega project to provide unique identification number to each of its 1.25 billion people. The identification number will be stored in central database consisting the biometric information of the individual. If implemented, this would be biggest implementation of biometrics in world. India's home minister, P. Chidambaram, described the process as “ the biggest exercise.....since humankind came into existence ”. The government will then use the information to issue identity cards known as AADHAR CARD. The main biometric features of this project includes collecting finger print, collecting images of iris, taking photographs. The entire exercise is performed by Unique Identification Authority of India (UIDAI) [17].

Literature Survey

Biometric technology in general and its implementation by Government of India for “AADHAR CARD” to be implemented by Unique Identification Authority of India (UIDAI) in particular is identification and access control [1]. This exercise is primarily to make socially and economically excluded vulnerable section of Indian population, a part of growth momentum while excluding those who are economically capable of availing services with government support. Apart from these very basic benefits implementation of biometric technology in such a diverse and cosmopolitan society, the roads divide into many different directions leading to better public service.

Biometric features are distinctive, measureable characteristics used to describe individuals. More traditional means of access control include token-based identification systems, such as a driver's license or passport, and knowledge-based identification systems, such as a password or personal identification number[2]. The two categories of biometric identifiers include physiological and behavioural characteristics [3]. Many different aspects of human physiology, chemistry or behaviour can be used for biometric authentication. The selection of a particular biometric for use in a specific application involves a weighting of several factors. Jain *et al.* (1999) [4] identified seven such factors to be used when assessing the suitability of any trait for use in biometric authentication viz. Universality, Uniqueness, Permanence, Measurability, Performance, Acceptability and Circumvention. No single biometric will meet all the requirements of every possible application [4]. Hence, usage of biometric technology depends upon the application to be achieved. Three steps involved in person verification [5]. In the first step, reference models for all the users are generated and stored in the model database. In the second step, some samples are matched with reference models to generate the genuine and impostor scores and calculate the threshold. Third step is the testing step. This process may use a smart card, username or ID number (e.g. PIN) to indicate which template should be used for comparison. In Identification mode, the system performs a one-to-many comparison against a biometric database in attempt to establish the identity of an unknown individual. The system will succeed in identifying the individual if the comparison of the biometric sample to a template in

the database falls within a previously set threshold. Identification mode can be used either for 'positive recognition' (so that the user does not have to provide any information about the template to be used) or for 'negative recognition' of the person "where the system establishes whether the person is who she (implicitly or explicitly) denies to be [3]. If enrolment is being performed, the template is simply stored somewhere (on a card or within a database or both). If a matching phase is being performed, the obtained template is passed to a matcher that compares it with other existing templates, estimating the distance between them using any algorithm (e.g. Hamming distance). The matching program will analyse the template with the input. This will then be output for any specified use or purpose. Selection of biometrics in any practical application depending upon the characteristic measurements and user requirements [5]. Adaptive biometric Systems aim to auto-update the templates or model to the intra-class variation of the operational data [6] while there are several open issues involved with these systems. For misclassification error (false acceptance) by the biometric system, cause adaptation using impostor sample. However, continuous research efforts are directed to resolve the open issues associated to the field of adaptive biometrics. More information about adaptive biometric systems can be found in the critical review by Rattani et al [7].

One advantage of passwords over biometrics is that they can be re-issued. If a token or a password is lost or stolen, it can be cancelled and replaced by a newer version. This is not naturally available in biometrics. If someone's face is compromised from a database, they cannot cancel or reissue it. Cancel able biometrics is a way in which to incorporate protection and the replacement features into biometrics. Ratha et al [8] first proposed it. Several methods for generating new exclusive biometrics have been proposed. The first fingerprint based cancellable biometric system was designed and developed by Tulyakov et al [9]. The variability in the distortion parameters provides the cancellable nature of the scheme. Some of the proposed techniques operate using their own recognition engines, such as Teoh et al [10] and Savvides et al. [11], whereas other methods, such as Dabbah et al. [12], take the advantage of the advancement of the well-established biometric research for their recognition front-end to conduct recognition.

Iris recognition is an automated method of biometric identification that uses mathematical pattern-recognition techniques on images of the iris of an individual's eyes, whose complex random patterns are unique and can be seen from some distance.

The first phase of iris Biometric systems is capturing the sample of the iris. Then iris samples are pre-processed and segmented to locate the iris. Once the iris is located, it is then normalized from polar coordinate to Cartesian. Finally, a template representing a set of features from the iris is generated. The iris template can then be objectively compared with other templates in order to determine an individual's identity. Most biometric systems allow two modes of operation. An enrolment mode for adding templates to a database, and an identification mode, where a template is created for an individual and then a match is searched from a database of pre-enrolled templates.

The microscopic view of human iris with specifications viz. usual diameter as well as general variations in size of pupil is best presented Sanderson S. et al. [13]. The anatomy of eye is explained with technical specifications by E.Wolff [14]. Seminal work, which forms the basis of present day iris recognition technology, is named after Cambridge Professor John Daugman in “Biometric personal identification system based on iris analysis” [15] is patented work. “How iris recognition works”[16] states that algorithms developed by the author for recognizing persons by their iris patterns have now been tested in many field and laboratory trials, producing no false matches in several million comparison tests. The combinatorial complexity of this phase information across different persons spans about 249 degrees of freedom and generates a discrimination entropy of about 3.2 b mm^2 over the iris, enabling real-time decisions about personal identity with extremely high confidence. The high confidence levels are important because they allow very large databases to be searched exhaustively (one-to-many “identification mode”) without making false matches, despite so many chances. Biometrics that lack this property can only survive one-to-one (“verification”) or few comparisons. This paper explains the iris recognition algorithms and presents results of 9.1 million comparisons among eye images from trials in Britain, the USA, Japan, and Korea. The Daugman algorithm first locates the pupillary and limbic boundaries of the iris using an integrodifferential operator that finds the circles in the image where the intensity is changing most rapidly with respect to changes in the radius. Once located, the iris image is converted to a Cartesian form by projecting it to onto a

dimensionless pseudo-polar coordinate system. The iris features are encoded and a signature is created using a 2-D complex-valued Gabor filter, where the real and imaginary parts of each outcome are assigned a value of 0 or 1 according to whether they are negative or positive, i.e. only the quadrant of the phase is encoded. Finally, two images are said to be independent if their fractional Hamming distance (H_d) is above a certain threshold, about .33. Otherwise, they are a match. Here, H_d equals number of mismatching bits divided by number of compared bits. The implementation as well as technological specification in relation to “Aadhar Card” to be implemented by Unique Identification Authority of India (UIDAI) are comprehensively dealt in working papers [17, 18] as well as biometric standards committee report [19-21]. R.Wildes in Iris Recognition: an emerging biometric technology [22] states that formation of iris is independent of genetic factors. Even though the Daugman system is the most successful and most well known, many other systems have been developed. The most notable include the systems of Wildes et al. [22,23], Boles and Boashash [24], Lim et al. [25], and Noh et al. [26]. Wildes et al. [23], Kong and Zhang [27], Tisse et al. [28], and Ma et al. [29] employ switching over to segmentation part, an automatic segmentation algorithm based on the circular Hough transform. The Wildes [23] algorithm locates the iris boundaries by creating a binary edge map using gradient-based edge detection, and then finds the centres and radii of these circles via a Hough Transform. The upper and lower eyelids are located similarly using parabolic arcs. Rather than map every iris image to a common system of polar coordinates, the Wildes algorithm compares two images by geometrically warping one image, via shifting and rotation, until it is a best fit with the other image, in the sense of minimizing mean square distance. A Laplacian pyramid is constructed at four different resolution levels to encode the image data. Matching is achieved via an application of normalized correlation and Fisher’s linear discriminant. Boles and Boashash [24] have given an algorithm that locates the pupil centre using an edge detection method, records grey level values on virtual concentric circles, and then constructs the zero-crossing representation on these virtual circles based on a one-dimensional dyadic wavelet transform. Corresponding virtual circles in different images are determined by rescaling the images to have a common iris diameter. The authors create two dissimilarity functions for the purposes of matching, one using every point of the representation and the other using only the zero crossing points. Lim et al. [25] proposes that following a standard iris localization and conversion to polar coordinates relative to the centre of the pupil, the authors propose alternative

approaches to both feature extraction and matching. An algorithm developed by Noh [26], et al., performs a comparison of different feature extraction techniques including Gabor wavelets, Haar wavelets, DAUB4 wavelets, Independent Component Analysis (ICA), and Multiresolution ICA (M-ICA). ICA is an unsupervised learning algorithm using high-order statistics, and M-ICA is a new method of feature extraction, introduced by these authors. The Fisher Discrimination Ratio is used as a comparison tool. Kong and Zhang [27] present a method for eyelash detection, where eyelashes are treated as belonging to two types, separable eyelashes, which are isolated in the image, and multiple eyelashes, which are bunched together and overlap in the eye image. Tisse, et al. [28], present a modification of Daugman's algorithm, with two major differences. The two innovations are in the iris location and feature extraction stages. The use of dimensionless polar coordinates and Hamming distance remain the same. To locate the iris, the Tisse algorithm applies a gradient decomposed Hough Transform to find the approximate centre of the pupil, and then applies the integrodifferential operator, as in Daugman's algorithm, to find the precise locations of the iris boundaries. This combined approach has the advantage of avoiding errors due to specular reflection in the images. In the feature extraction and encoding step, the Hilbert Transform is used to create an analytic image, whose output is then encoded as an emergent frequency vector and an instantaneous phase. This approach has an advantage of being computationally efficient. The integro-differential [15,16] can be seen as a variation of the Hough transform, since it too makes use of first derivatives of the image and performs a search to find geometric parameters. Ma et al. [29] discusses iris recognition using circular symmetric filters. Ritter et al. [30] make use of active contour models for localising the pupil in eye images. Active contours respond to pre-set internal and external forces by deforming internally or moving across an image until equilibrium is reached. The normalisation part can be well versed from Daugman seminal work [15,16] known as Daugman's rubber sheet model which remaps each point within the iris region to a pair of polar coordinates (r, θ) where r is on the interval $[0,1]$ and θ is angle $[0,2\pi]$. The Wildes et al. system employs an image registration technique, which geometrically warps a newly acquired image, into alignment with a selected database image [22,23]. In the Boles [24] system, iris images are first scaled to have constant diameter so that when comparing two images, one is considered as the reference image. This works differently to the other techniques, since normalisation is not performed until attempting to match two iris regions, rather than performing normalisation and saving the result for later

comparisons. Feature Encoding in iris recognition technology is full of commendable works. A number of wavelet filters, also called a bank of wavelets can be used to decompose the data in the iris region into components that appear at different resolutions. Wavelets have the advantage over traditional Fourier transform in that the frequency data is localised, allowing features which occur at the same position and resolution to be matched up. When applied to the 2D iris region, one for each resolution with each wavelet a scaled version of some basis functions. The output of applying the wavelets is then encoded in order to provide a compact and discriminating representation of the iris pattern. Thoughtful and detailed discussions of iris recognition can be found in [31,32], where Tan and his colleagues from China suggest several innovations, and then provide a comparison of different methods and algorithms. The iris is localized in several steps which first find a good approximation for the pupil centre and radius, and then apply the Canny operator and the Hough transform to locate the iris boundaries more precisely. The iris image is converted to dimensionless polar coordinates, similarly to Daugman, and then is processed using a variant of the Gabor filter. The dimension of the signature is reduced via an application of the Fisher linear discriminant. The L1 distance, L2 distance (i.e. Euclidean distance), and cosine similarity measures are considered for matching. A careful statistical performance evaluation is provided for the authors' work, and for most of the well-known algorithms mentioned above. Several interesting ideas can also be found in the work of Du, et al., see [33]. Edge detection is performed using the Canny method, and each iris image is then transformed to standardized polar coordinates relative to the centre of the pupil. MahboubehShamsi et al. [34] and L. Masek [35] discusses iris recognition technology in details which is worth provides valuable insight to present work. The feature extraction stage is quite different from those mentioned previously, and is simple to implement. The authors use a grey scale invariant called Local Texture Patterns (LTP) that compares the intensity of a single pixel to the average intensity over a small surrounding rectangle. For feature extraction, they compare the use of the Gabor Transform and the Haar Wavelet Transform, and their results indicate to them that the Haar Transform is somewhat better. The matching process uses an LVQ competitive learning neural network, which is optimized by a careful selection of initial weight vectors. Gabor filters are able to provide optimum conjoint representation of a signal in space and spatial frequency. A Gabor filter is constructed by modulating a sine/cosine wave with a Gaussian. This is able to provide the optimum conjoint localisation in both space and frequency, since a sine wave is perfectly

localised in frequency, but not localised in space. Daugman demodulates the output of the Gabor filters in order to compress the data. This is done by quantising the phase information into four levels, for each possible quadrant in the complex plane. Oppenheim has showed it and Lim [36] that phase information, rather than amplitude information provides the most significant information within an image. Tai Sing Lee [37] comprehensively deals a detailed study of 2D Gabor wavelets while Field [38] examines details regarding Log-Gabor filter. Boles and Boashash [24] make use of 1D wavelets for encoding iris pattern data while Lim et al.[25] compare the use of Gabor transform and Haar wavelet transform, and show that the recognition rate of Haar wavelet transform is slightly better than Gabor transform by 0.9%. Burt and Adelson [39] construct a Laplacian pyramid with four different resolution levels in order to generate compact iris template details of Laplacian Pyramids are presented. The literature consisting of matching algorithms in iris recognition mainly deals with three types viz. Hamming distance algorithm, weighted Euclidean distance, and normalised correlation. The Hamming distance is the matching metric employed by Daugman, and calculation of the Hamming distance is taken only with bits that are generated from the actual iris region. The weighted Euclidean distance (WED) employed by Zhu et al. [40] can be used to compare two templates, especially if the template is composed of integer values. The weighting Euclidean distance gives a measure of how similar a collection of values are between two templates. Wildes et al. [22,23] Wildes et al. make use of normalised correlation between the acquired and database representation for goodness of match. Gibbs research [41] gives one of the most important fundamentals not only to our work but to whole work done on visual environment. He stressed that one must understand the nature of the environment before one can understand the nature of visual processing. However, his comments have gone largely unheeded in the mainstream of vision research. There seems to be a belief that images from the natural environment vary so widely from scene to scene that a general description would be impossible. Thus an analysis of such images is presumed to give little insight into visual function. Moreover the definition of an efficient, or optimal, code depends on two parameters: the goal of the code and the statistics of the input. The database [42] of sample images is saved from the images available on IIT Delhi Iris database site.

Research Question, Motivation and Justification

In the present chapter we will highlight the research question which constitutes the present work as well as a gap analysis between the existing work and targeted work, both in terms of on going practicality achieved so far by existing work and technological advancement available, which inherently gives us motivation for our present work. Moreover a justification is also presented in order to answer the question that why we have chosen to work in this dimension of biometric systems.

3.1 Research Question

The objective of present work is a self-memorandum which revolves around “To Study and Implement Iris Recognition to Give First-hand Experience to An Alternative Approach to Government of India for ‘AADHAR CARD’ to be Implemented by Unique Identification Authority of India (UIDAI)”. The alternative approach is based on the premise that as existing work are patented and need to search the iris boundaries over large parameter space exhaustively, which takes more computational time. Moreover, they may result in circle detection failure, because some chosen threshold values used for edge detection cause critical edge points being removed. In this work, we implement simple method for iris recognition in iris images to implement in day to day life, using MATLAB®. The emphasis will be only on the software for performing recognition, and not hardware for capturing an eye image.

3.2 A Gap Analysis Between The Existing Work And Targeted Work

As stated above, the existing work will be seen through two different lenses viz. The on going practicality achieved as well as the technological advancements made in relation to Iris recognition. Firstly we will throw light on the first part and will try to analyse what are the means and ends to this technology when we bring this technology into real life arena. We will also analyse different kinds of problems and challenges faced by researchers and scientific community in its implementation within India when we talk about the biggest ever biometric system implementation is going on in particular as well on going implementation drives in other

countries around the world in general. The practicality will be analysed in a multidimensional viewpoint encompassing the economy, technological, demographic, societal as well as ground realities taken into account. After having a comprehensive as well as bird's eye view on the above said matter the stage light will be thrown on the technological advancements present today which finally culminates by providing motivation to our present work.

3.2.1 Implementation Perspectives In India : Challenges Faced And Opportunities Explored

The present platform will focus on the biometric technology of the UID project for the purposes of UID enrollment. It goes into the proof of concept studies conducted in India, analysis of the study results, design decisions on biometric modes necessary in the Indian context, implementation of client and server side systems for enrollment with the accuracy and performance achieved by the UID biometric system. It is not possible to de-duplicate 1.2 billion residents by using demographic fields only (like name, address, age, gender etc) and moreover identity documents that rely only on demographic fields and personal reference checks are surrogates of identity and are vulnerable to forgery, falsification, theft, loss and other corruptions. In Indian context, biometrics were determined to be the most suitable factors for carrying out de-duplication. Hence it becomes necessary to enrol all residents along with their biometrics and build a clean database for the purposes of a National Identity system. The goal of the UID project is to assign a unique Identification number to each resident of India. The uniqueness constraint implies that during enrolment stage (creation of Aadhaar) each person will get one and only one Aadhaar number. To ensure that each person gets one and only one Aadhaar number it is necessary that the resident's identity information is captured and matched against every other resident (1:N check) who have previously enrolled - This process is called de-duplication.

3.2.1.1 Proof-of-Concept Study (PoC)

The UIDAI conducted a Proof-of-Concept study during Mar-June 2010 in predominantly rural areas of Andhra Pradesh, Karnataka and Bihar published a report in December 2010 whose key findings included:

- Iris enrollment took less than a minute to capture and could be captured effectively from people, even from those who were blind.

- Children between 4-15 years could be biometrically enrolled correctly, and could be de-duplicated as accurately as adults.
- The accuracy levels achieved with a combination of fingerprint and iris were more than an order of magnitude (10x) better than using one or the other.

The PoC report concluded that “The biometric matching analysis of 40,000 people showed that the accuracy levels achieved using both iris and ten fingerprints were more than an order of magnitude better compared to using either of the two individually. The multi-modal enrolment was adequate to carry out de-duplication on a much larger scale, with reasonable expectations of extending it to all residents of India”.

3.2.1.2 Biometric Accuracy and Effectiveness

In the last few months there have been media reports with misconceptions about the accuracy and efficacy of the UIDAI’s biometric system. The Parliamentary Standing Committee on Finance(2011-12) that reviewed the National Identification Authority of India bill has referred to an “expert” who has stated “it has been proven again and again that in the Indian environment, the failure to enrol with fingerprints is as high as 15% due to the prevalence of a huge population dependent on manual labour”. These misconceptions have been addressed below:

As of December 31st 2011, the UIDAI has true and tested statistics computed from real operational large-scale UIDAI system with the resident enrollment database size of 8.4 crore (84 million). It is unnecessary and inaccurate to attempt to infer UIDAI system performance from other systems which are ten to thousand times smaller. Specifically,

- Failure to Enroll(FTE) Rate: Zero: As a policy, every unique resident, regardless of their biometrics can be enrolled and issued Aadhaar number.
- Biometric Failure to Enrol Rate: 0.14%.This implies that 99.86% of the population can be uniquely identified by the biometric system. The exceptions (0.14%) however are de-duplicated using demographic data and checked manually for fraud. The legitimate cases among these are issued Aadhaar number.

- False Positive Identification Rate (FPIR): 0.057%. In practical terms, it means that at a run rate of 10 lakh enrolments a day, only about 570 cases need to be manually reviewed daily to ensure that no resident is erroneously denied an Aadhaar number. The UIDAI currently has a manual adjudication team that reviews and resolves these cases. After manual adjudication, there is a negligible number of legitimate residents who are wrongly denied an Aadhaar number.

- False Negative Identification Rate (FNIR): 0.035%. This implies that 99.965% of all duplicates submitted to the biometric de-duplication system are correctly caught by the system as duplicates. Given that currently approximately 0.5% of enrolments are duplicate submissions, only a few thousand duplicate Aadhaars would possibly be issued when the entire country of 120 crores is enrolled.

UIDAI has adopted use of biometrics technology as part of its core strategy in meeting its goal of preventing issuance of duplicate identity number to a resident. There is no method or technology, other than biometrics, that can catch a person who is disclaiming his real identity. Biometrics consists of methods for uniquely recognizing human beings based on one or more of their intrinsic physical or behavioural traits. By matching a person's biometric characteristics with everyone else's (known as de-duplication), the technology helps prevent issuance of duplicate identity (Aadhaar number) to a single person[17].

Identity documents that rely only on demographic fields and personal reference checks are surrogates of identity and are vulnerable to forgery, falsification, theft, loss, and other corruptions. In western countries such as the United States and the United Kingdom, documents such as driver's license, and passports are used as identity proofs but only because of the reliability of the birth certificates. A birth certificate acts as a breeder document (in conjunction with identity documents of the child's parents) in obtaining identity document for the child. Even in countries with reliable birth certificates, the issuance of identity documents in a way that assures a 'one person/one identity' policy has been problematic. This model does not work in India, so UIDAI's strategy has been to minimize dependence on unreliable breeder and identity documentation and to not depend upon the trustworthiness of the operator, but rather to leverage automation and technology in a way that reduces the total dependence on error-prone documents and people based processes.

The key findings of the PoC report, which have been presented internationally at scientific conferences and received extensive peer review, are listed here:

The PoC was successfully conducted over 1,35,000 biometric enrolments. The relative ease of conducting the operation confirmed that biometric enrolment conforming to UID standards of quality and process was indeed possible on a large scale in rural India. The total biometric enrolment time for each individual, on average, was a little over three minutes. Of this, iris enrolment took a little under a minute, and was not perceived to be excessively difficult either by the resident or the enrolling operator. Specifically, many blind people also had their iris images captured successfully.

Multiple fingerprint scanners as well as iris capture devices were used in the PoC, and they performed according to expectations. The PoC was dispersed geographically and included many rural, often remote locations across three states. The enrolment was typically conducted with minimal infrastructure and sometimes in extreme weather conditions. Residents varied in age all the way from four years to about ninety years.

In general older people took longer to enroll than younger people, and residents whose employment involved manual work took longer to enroll than the rest of the PoC population. Older people needed more assistance from operators to capture their biometrics. However, the range of enrolment times observed was well within expectations implying that the enrolment exercise for the population was indeed practical.

The enrolment variations tested in the process led to the conclusion that the best process was one where the resident remained stationary during enrolment and the operator did the positioning of the devices.

The enrolment of children at the school showed that children in the age range of four to fifteen could be biometrically enrolled using the same process as that used for adults and with no additional difficulty. The match analysis also showed that their iris images and fingerprints could be de-duplicated as accurately as those of adults.

The quality of the biometric capture was sensitive to the setup of the enrolment station and the process itself. Most importantly, the enrolment operator's instructions made a significant difference in the efficiency of the biometric capture.

The quality check process built into the enrolment software was very important and provided helpful feedback to the operator in capturing high quality images. The biometric matching analysis of 40,000 people showed that the accuracy levels achieved using both iris and ten fingerprints were more than an order of magnitude better compared to using either of the two individually. The multi-modal enrolment was adequate to carry out de-duplication on a much larger scale, with reasonable expectations of extending it to all residents of India.

As of December of 2011, UIDAI has documented measurements taken from the real large-scale operational UIDAI system that has already issued over 10.25 crore (102.5 million) Aadhaar numbers.

Following Biometric Standards Committee report, expert opinions, and learnings from the PoC, UIDAI selected three biometric modalities: face, all ten fingerprints and two irises. The decision to include iris in the UID initiative was a considered one, and took into account the critical needs of the project in ensuring the uniqueness of the Aadhaar number, and to also ensure that residents, particularly children and the elderly, are not excluded from enrolling for the UID. The PoC empirically demonstrated that iris is easy to capture, highly accurate, and not too expensive. By guaranteeing the universality and uniqueness of the UID, the initiative can have a substantial, transformational impact in the lives of residents[18].

While the UIDAI Biometrics Standards Committee had already recommended the inclusion of iris, the PoC clearly demonstrated that iris capture was indeed necessary, and along with fingerprint, it was sufficient to de-duplicate and uniquely identify the entire population. The accuracy of the combined system is an order of magnitude better than fingerprints alone or iris alone, an important factor to consider for a population of 120 crore, and if the unique number is to be usable in high-security applications. Another reason for adding iris was inclusion. The use of iris also enables us to ensure the inclusion of the very poor, many of who work in physically intensive jobs, as well as children and the elderly. People working in jobs that require repeated use of fingers— for example, in fireworks factories or in areca nut plantations – often find their

fingerprints degraded, which makes iris useful in ensuring uniqueness. The challenge with both fingerprint and face biometrics is that these have limitations when it comes to providing a unique number to children. Iris biometrics however, is reasonably stable in most persons, and can be collected from children as young as five years of age. This is an important factor considering the multiple programs aimed at child welfare.

The enrollment system is designed in two major parts: i) client-side and ii) server-side. The client-side is responsible for operator-assisted collection of relevant data from the resident in the field. The data is collected by client software provided by UIDAI which immediately encrypts and applies a digital signature to the data so that no one other than UIDAI's server can decrypt it, not even the operator, enrolling agency or even the registrar. Since data is encrypted, UIDAI's multi-registrar approach improves scalability and provides choice to residents without any negative effects on the data security. The encrypted data is transmitted to UIDAI Central Information Data Repository (CIDR) where it is fed to the server-side system. The backend server-side system uses multiple automatic biometric identification systems (ABISs) to determine whether the resident is unique (that is, the resident has never received another Aadhaar number before). The Aadhaar letter containing the UID number (assuming that the server found the resident to be unique) is sent from the server-side system back to the resident through a letter delivered by the department of post [18].

Enrollment software: Client side

- Standardization
- Open source and avoidance of vendor lock-in
- Quality
- Security

Enrollment software: Server side

- Demographic de-duplication
- Multi-ABIS Multi-modal Biometric de-duplication (using multiple ABISs and multi-modal biometrics of 10 fingerprints and 2 irises)

- Manual adjudication (primarily to resolve records identified as duplicates found by previous stages)

3.2.1.3 The need for iris in the UID Project

3.2.1.3.1 Ensuring uniqueness

The Biometrics Committee played a key role in helping the UIDAI determine the biometrics to be used in UID enrolment, and the standards to be adopted. The Committee submitted its report on 7th January 2010 to the Chairman of the UIDAI [19]. Prior to recommending the type of biometrics to be captured, the Biometrics Committee debated a key challenge that the UIDAI faces – that of ensuring the uniqueness of biometrics across a population of 1.2 billion people. To ensure uniqueness, the UIDAI has to minimize the false acceptance rate (FAR) in its biometrics. However, the Biometrics Committee noted that the approach using fingerprint biometrics alone, in addition to face, faces two challenges in ensuring uniqueness and low FAR within the Indian environment – the varying quality of fingerprints, particularly among poor residents; and the scale of the database, at 1.2 billion records. Both these challenges could make uniqueness in biometrics difficult to achieve. The risk that fingerprinting may not be sufficient to ensure uniqueness is not a risk that can be ignored, particularly when enrolling residents on such a large scale. The cost and logistics of going back and re-enrolling residents, in case the biometrics set is insufficient, would be unacceptable. The addition of iris to finger and face biometrics would help the UIDAI achieve accuracy rates that go beyond 95%, and would ensure very low FAR. This will also make the UID number highly robust, and enable the number to be used in a wide variety of applications that require high security, such as in financial transactions. Consequently, the Biometric Committee, following consultations with international experts, recommended that combining the use of two biometrics – fingerprints and iris – would help ensure the uniqueness and accuracy of biometrics in the Indian context. The report stated, ‘fused score of two uncorrelated [biometric] modalities will provide better accuracy than any single modality[20].

3.2.1.3.2 Ensuring inclusion

The addition of the iris to the biometric information the UIDAI collects is also important to ensure the inclusion of the large part of the population. There are two important challenges of inclusion that the UIDAI faces:

Ensuring the inclusion of poor residents: India faces unique challenges in collecting biometrics from its rural population and the poor. The poor, due to occupations that usually involve physical labour, have fingerprints that are worn out and difficult to capture [20]. Experts estimate that the challenges in collecting the biometrics of the poor would be lower in the case of iris devices. The iris does not get worn out with age, or with use. It even remains unaffected by most eye surgery. Consequently the use of iris biometrics would help ensure that poor residents are not left out of UID enrolment.

Ensuring the inclusion of children: Collecting and de-duplicating the biometrics of children is a challenge – face and finger biometrics are not stable until the age of 16. The lack of de-duplication of a child's biometrics would require that the child's UID be linked to the parents' UIDs in the database and the child's ID is not issued on the basis of deduplication of his/her biometrics. This however, increases the risk of duplicates/fakes among UIDs for children. Such UIDs would represent a significant proportion of the UIDs issued, since the percentage of population below 15 years of age is 35.3% as per the 2001 Census. The iris presents a potential means to issue the majority of children a unique number linked to their biometrics, since the iris stabilizes at a very young age. Unlike fingerprints, the iris is said to be fully developed at the time of birth itself. The limitation on iris capture of a child only due to the requirement for a child to follow the instructions of keeping his/her eyes open before the iris camera. On an average, the age at which the child can understand and follow such instructions will be around 4 years. The use of iris, would enable to reduce the size of our inaccurate UID sub-set (due to the inability to de-duplicate) from 35% to 11% (the percentage of population below four years of age as per the 2001 Census). This will be a significant gain in terms of accuracy [21].

3.2.1.3.3 Other benefits

There are other additional benefits from collecting iris, along with face and fingerprints.

These include:

Comfort: The addition of iris as a third biometric would not be intrusive. Iris image capture is normally done at a distance of 18" to 24", and the image can be taken quite quickly, in less than fifteen seconds per image. The experience is similar to having the resident's photograph taken, except that the camera is brought closer to the face during capture of the image.

Ease of use: Both fingerprint devices and iris devices are not difficult to use with trained operator. Newer iris devices however, are also auto-focus and auto-capture and will prevent the operator from taking an out-of-focus image.

Reducing risks in execution: UID enrolment will take place on a large scale and in diverse environments across the country. While the enrolment processes and systems will be standardised, the UIDAI cannot guarantee high quality across its thousands of enrolment points. Collecting iris in addition to fingerprints will help limit the risk of low quality in the biometric data collected.

Reducing technology risks: There are significant technology risks in the UID project – there are for instance, no examples to follow, with no previous such technology implementations of this scale. The project also pushes the boundaries of existing de-duplication and authentication technologies, due to the project's unprecedented size. While ten fingerprints, when collected with care with special emphasis on quality can give us high accuracy, this faces some uncertainties, considering the technology challenges stated above. The use of iris as an additional (and uncorrelated) biometric mitigates the project's technology risks considerably.

De-duplication Process: During the deliberations of the Biometrics Committee, it was pointed out by experts that iris de-duplication is today, much faster than finger-print de-duplication. More importantly, multi-modal de-duplication, while keeping iris as the primary means of de-duplication, can be made to work much faster than single mode de-duplication. Given the flexibility that the UIDAI wants on de-duplication, and the possibility that the UIDAI may like to reduce the time taken to achieve universal coverage, the speed of finger-print de-duplication should not become a limiting factor in project implementation [21].

Applications: The requirement of uniqueness and accuracy in UID-linked biometrics is a function of the applications which utilize the residents' data. The applications that use the UID would be many and varied – as an example, an application may use UIDs to monitor the coverage of immunizations, and may not require very significant accuracy. However, if UIDs are to be used to authenticate financial transactions and micro-payments, then even a small percentage of inaccuracies in UID-linked biometric data may make the data unusable for these

purposes. Hence, compromises made on uniqueness and accuracy may limit the use of the UID in critical applications.

Security: It is highly desirable to have access to an additional biometric trait, from the viewpoint of national security. It is possible to disguise facial features, and mask fingerprints through cuts and bruises. It is much harder to alter iris along with the face and fingerprint. Iris use has consequently become more common in national security and border control applications worldwide.

Future development of identity systems: The use of biometric systems for verifying identity is growing rapidly around the world, and both fingerprint and iris vendors are expanding their market. The use of both iris and fingerprint within the UID project will ensure that the number is still usable, if either technology gains ground for identity verification in the future.

Before we go further we need to answer some of the questions raised at various forums about iris recognition in the implementation as this critical analysis will enhance our confidence as well as remove various misconceptions towards our targeted work.

Is iris a new, untried technology?: There is some worry that iris technology is new and untested. While fingerprint recognition is over 150 years old, iris matching was patented only forty years ago. However even in this short span of time, iris has got a reputation for high accuracy, and is widely used in security and access control applications where accuracy is paramount. Iris technology has been used both in India and internationally with success. The UK, Canada, US and the UAE are using iris extensively for identity verification and de-duplication at their borders. In Andhra Pradesh, the Ministry of Civil Supplies has implemented iris technology across its database of ration card holders, with anecdotally low reject rates and high enrolment. This has been supported by experiences with iris in Orissa, within a pilot for the UNFWP program. As NIST reports, “Iris recognition [matches] the level of technical maturity and interoperability of fingerprint bio- metrics, and has affirmed the potential for using iris biometrics...for large-scale identity management applications.”

Is manufacturing capacity available for iris capture devices?: As iris is a relatively new technology and its usage is limited, the manufacturing capacities in existence today is not significant. Hence, the concern is that if iris is included in the biometric set for UIDAI project,

there will be a large demand for iris capture equipment which won't be fulfilled, and the implementation will be affected due to the limited production capacity in the industry. However manufacturing capacity of iris vendors is at present, determined by existing demand. The UIDAI project would create substantial, new demand for iris devices, and the manufacturing capacity will go up over the coming years. This will also present Indian vendors with an opportunity to enter this space, and has the potential to make India a hub for biometric device manufacturing. The exponential use of consumer grade digital cameras has also helped reduce the manufacturing cost and complexity of iris camera.

Will collecting iris biometrics be expensive?: A concern with iris has been on cost. However, the current high prices for iris technology are a result of low volume and its use in cost insensitive security applications. Considering the large demand that will come from India for iris devices and software, the UIDAI expects the prices for iris devices and software will fall rapidly. The UIDAI, taking into account expert assessments, expects iris software to be less expensive by 30-50% compared to fingerprint matching software. When it comes to enrolment, logistics (travel, manpower etc.) contributes to the major part of the enrolment cost. The cost of the biometric capture devices (equipment and its operation) is not a substantial portion of the cost. A rough estimate puts the incremental cost for iris enrolment in 2010 is to be Rs. 4.4 per enrollee, which will fall over the next few years as the project scales up. The estimated incremental cost is less than Rs. 3 for the iris device, Rs. 0.75 in labour cost and Rs. 0.75 for software cost per enrollee. Considering the risks discussed previously and the value addition that iris inclusion provides, the additional cost is definitely acceptable for a project of this size and importance. In fact, the cost-benefit ratio, if computed rigorously, will be overwhelmingly in favour of including iris in the biometrics set for the UIDAI. At a macro level, the use of iris will add an estimated Rs. 500 crores to the project cost. This is well worth the improvements and value addition that the iris biometric will provide.

Will agencies be required to use iris reader devices to authenticate residents?: It would not be necessary for agencies to authenticate residents through iris. The use of iris biometrics in the UID project is primarily required for a) inclusion of the poor, and b) for de-duplicating the resident before enrolment, which requires extremely high accuracy since the biometric record is compared to the entire database (1:N comparison). For authentication, the use of fingerprinting

will be sufficient, since the comparison would be between the biometric collected by the agency, and the UID-linked biometric in the database (1:1 comparison). However, having iris in our database will enable any future iris-based authentication systems – such as at the airports and other high security areas.

Is iris difficult to capture?: One apprehension that exists is that the iris is difficult to capture and the failure to register rate (FRR) are very high. This concern is also based on the fact that earlier iris capture devices were relatively primitive and inconvenient to use. During the last couple of years however, there have been significant improvements in camera quality, and there are now autofocus cameras available which capture the iris image more or less the same way a picture is taken by a normal digital camera. The Andhra Pradesh government for example, captured about 50 million iris images with earlier cameras without any serious difficulty. Ease of use of iris capture cameras has improved even further today. It is mistakenly thought in some quarters that iris capture will be opposed due to religious/ethnic sensitivities or due to other reasons (rumors of laser beams going into the eye and damaging it). This has not been found to be true in the real world, and no such cases have been reported in the use of iris capture. In fact, in countries such as the UAE where there are strong cultural sensitivities, iris is being widely used in national programs.

3.2.2 Ongoing Implementations in The World

Mexico's Social Security System : Mexico is the first large country that has collected fingerprint, iris and face biometrics of the entire adult population, in order to provide social benefits. Prior to 2009, Mexico has had a comprehensive social security program for its residents which used their version of a unique ID number, which included fingerprints of two fingers. In 2009, Mexico decided to add full biometric data to their Unique ID project, and awarded the contract in December 2009 and January 2010 to a group of companies for the collection of 10 fingerprints, dual iris and face photograph. Mexico's reasons for including iris in its program have been uniqueness, ensuring the inclusion of the poor and high accuracy.

The UAE guest worker program :The UAE guest worker program is the largest national deployment so far of iris technology. The program has deployed iris-based enrolment and

identity verification across the country's 17 air land and sea ports, and is now in its third year of operation. The program reports zero false matches.

Other implementations :Canada, UK, Netherlands and Singapore now use iris for border control and immigration. The FBI in the USA has also begun collecting and storing iris images along with fingerprint and photo.

3.3 Gap Analysis From Technological Perspective : Lets Now Tilt The Prism To See Full Rainbow

Now we have reached to a stage from where we can consider iris recognition technology, specifically taking into account various technological advancements available today. This critical analysis from technological perspective we enable us to acquaint ourselves towards the specifications of the technology while enabling us to build the theory particularly the part of technology we have dealt from our viewpoint. Seminal work of Daugman “How Iris Recognition Works” provides the most reliable technology while many researchers have put their contributions in the technology which is appreciably discussed in concise by Mahboubeh and others in their work “Iris Segmentation and Normalization Approach”, also the work of Libor Masek [35] is worth to look for. Basically the iris recognition technology have four basic technological modules which are implemented in sequence are :

1. Segmentation
2. Normalisation
3. Feature Encoding
4. Matching Algorithms

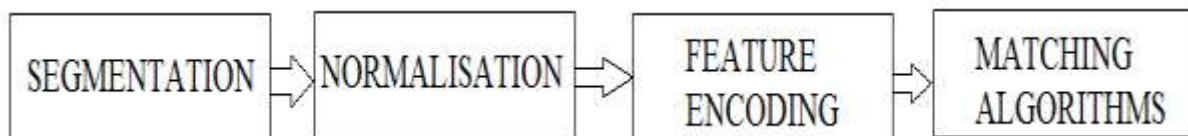

Figure3.1: Basic Technological Components of Iris Recognition Technology

3.3.1 Segmentation :

The very first module of iris recognition is to separate or segment the actual iris region in a digital eye image. The iris region, can be approximated by two circles, one for the iris/sclera boundary and another, interior to the first, for the iris/pupil boundary. The eyelids and eyelashes normally occlude the upper and lower parts of the iris region. Also, specular reflections can occur within the iris region corrupting the iris pattern. A highly efficient technique is required to isolate and exclude these artefacts as well as locating the circular iris region. This module of the technology is very crucial for the rest of the modules, since data that is falsely represented as iris pattern data will corrupt the biometric templates generated, resulting in poor recognition rates. Four main technological viewpoint discussed in segmentation module are :

1. Daugman's Integro-differential Operator
2. Hough Transform
3. Gaussian pyramid and canny edge detection method
4. Active Contour Models
5. Circular symmetric filters
6. Eyelash and Noise Detection

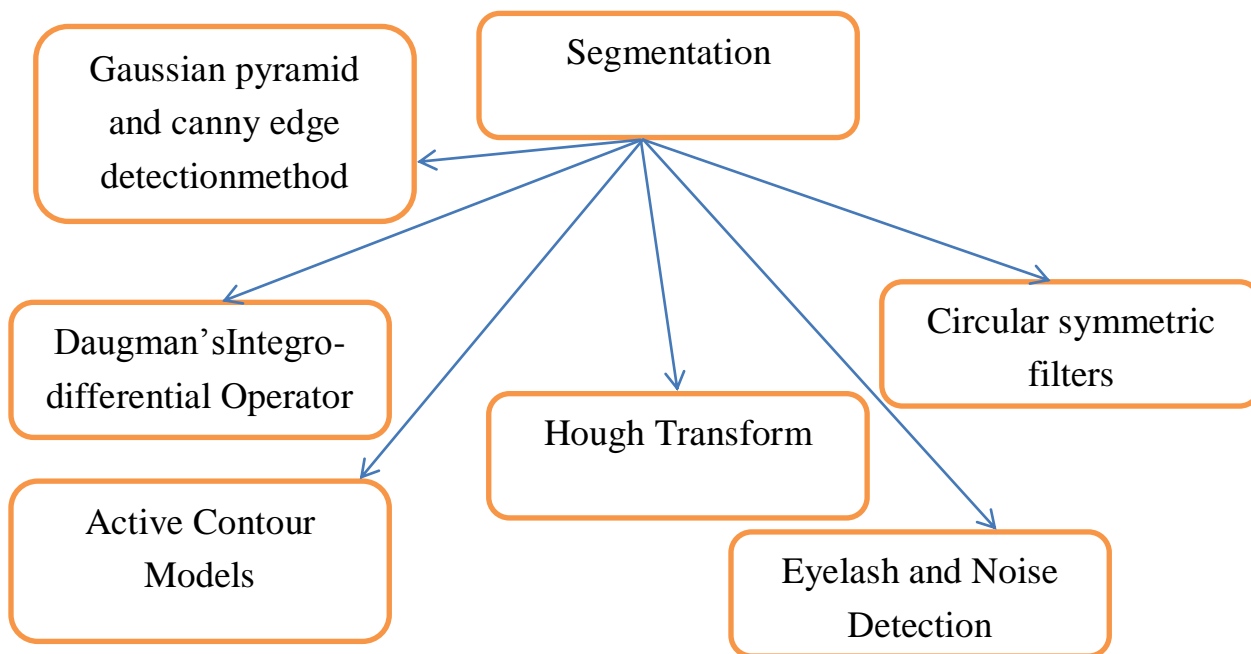

Figure3.2 : Technological Perspectives of Segmentation Module

Daugman's Integro-differential Operator

Daugman makes use of an integro-differential operator for locating the circular iris and pupil regions, and also the arcs of the upper and lower eyelids. The integro-differential operator is defined as

$$\max_{(r,x,y)} \left| G_{\sigma}(r) * \frac{\partial}{\partial r} \oint_{r,x,y} \frac{I(x,y)}{2\pi r} ds \right| \quad 3.3$$

where $I(x,y)$ is the eye image, r is the radius to search for, $G_{\sigma}(r)$ is a Gaussian smoothing function, and s is the contour of the circle given by r, x_0, y_0 . The operator searches for the circular path where there is maximum change in pixel values, by varying the radius and centre x and y position of the circular contour. The operator is applied iteratively with the amount of smoothing progressively reduced in order to attain precise localisation. Eyelids are localised in a similar manner, with the path of contour integration changed from circular to an arc.

The integro-differential can be seen as a variation of the Hough transform, since it too makes use of first derivatives of the image and performs a search to find geometric parameters. Since it works with raw derivative information, it does not suffer from the thresholding problems of the Hough transform. However, the algorithm can fail where there is noise in the eye image, such as from reflections, since it works only on a local scale.

Hough Transform Method

The Hough transform is a standard computer vision algorithm that can be used to determine the parameters of simple geometric objects, such as lines and circles, present in an image. The circular Hough transform can be employed to deduce the radius and centre coordinates of the pupil and iris regions. An automatic segmentation algorithm based on the circular Hough transform is employed by Wildes et al. [5], Kong and Zhang [16], Tisse et al. [17], and Ma et al. [18]. Firstly, an edge map is generated by calculating the first derivatives of intensity values in an eye image and then thresholding the result. From the edge map, votes are cast in Hough space for the parameters of circles passing through each edge point. These parameters are the centre

coordinates x and y , and the radius r , which are able to define any circle according to the equation

$$x^2 + y^2 - r^2 = 0 \quad 3.1$$

A maximum point in the Hough space will correspond to the radius and centre coordinates of the circle best defined by the edge points. Wildes et al. and Kong and Zhang also make use of the parabolic Hough transform to detect the eyelids, approximating the upper and lower eyelids with parabolic arcs, which are represented as;

$$(-(x - h) \sin \theta + (y - k) \cos \theta)^2 = a((x - h) \cos \theta + (y - k) \sin \theta) \quad 3.2$$

Where a controls the curvature, (h, k) is the peak of parabola and θ is the angle of rotation relative to the x -axis.

In performing the preceding edge detection step, Wildes et al. bias the derivatives in the horizontal direction for detecting the eyelids, and in the vertical direction for detecting the outer circular boundary of the iris. The motivation for this is that the eyelids are usually horizontally aligned, and also the eyelid edge map will corrupt the circular iris boundary edge map if using all gradient data. Taking only the vertical gradients for locating the iris boundary will reduce influence of the eyelids when performing circular Hough transform, and not all of the edge pixels defining the circle are required for successful localisation. Not only does this make circle localisation more accurate, it also makes it more efficient, since there are less edge points to cast votes in the Hough space.

There are a number of problems with the Hough transform method. First of all, it requires threshold values to be chosen for edge detection, and this may result in critical edge points being removed, resulting in failure to detect circles/arcs. Secondly, the Hough transform is computationally intensive due to its 'brute-force' approach, and thus may not be suitable for real time applications.

Gaussian pyramid and canny edge detection method

In this method the boundaries of the iris to be located are supposed to detect the part of the image that extends from inside the limbus (the border between the sclera and the iris) to the outside of

the pupil. Starting with determining the outer edge by first down sampling the images by a factor of 4, to enable a faster processing delay, using a Gaussian Pyramid after which the Canny operator with the default threshold value given by Matlab, to obtain the gradient image. Next, a Circular summation which consists of summing the intensities over all circles, by using three nested loops to pass over all possible radii and center coordinates is applied. The circle with the biggest radius and highest summation corresponds to the outer boundary. The center and radius of the iris in the original image are determined by rescaling the obtained results. After having located the outer edge, the intensity of the pixels within the iris is tested. Depending on this intensity, the threshold of the Canny is chosen. If the iris is dark, a low threshold is used to enable the Canny operator to mark out the inner circle separating the iris from the pupil. If the iris is light colored, such as blue or green, then a higher threshold is utilized.

Active Contour Models

Ritter et al. [19] make use of active contour models for localising the pupil in eye images. Active contours respond to pre-set internal and external forces by deforming internally or moving across an image until equilibrium is reached. The contour contains a number of vertices, whose positions are changed by two opposing forces, an internal force, which is dependent on the desired characteristics, and an external force, which is dependent on the image. Each vertex is moved between time t and $t + 1$ by

$$v(t + 1) = v(t) + F(t) + G(t) \quad 3.4$$

where F_i is the internal force, G_i is the external force and v_i is the position of vertex i . For localisation of the pupil region, the internal forces are calibrated so that the contour forms a globally expanding discrete circle. The external forces are usually found using the edge information. In order to improve accuracy Ritter et al. use the variance image, rather than the edge image.

A point interior to the pupil is located from a variance image and then a discrete circular active contour (DCAC) is created with this point as its centre. The DCAC is then moved under the influence of internal and external forces until it reaches equilibrium, and the pupil is localised.

Circular symmetric filters

A bank of circular symmetric filters is used to capture local iris characteristics to form a fixed length feature vector. The iris is localized in two steps: (1) approximate region of iris in an image can be found by projecting iris image in horizontal and vertical direction. (2) the exact parameters of these two circles are obtained by using edge detection and Hough transform in a certain region determined in the first step.

Eyelash and Noise Detection

Kong and Zhang [16] present a method for eyelash detection, where eyelashes are treated as belonging to two types, separable eyelashes, which are isolated in the image, and multiple eyelashes, which are bunched together and overlap in the eye image. Separable eyelashes are detected using 1D Gabor filters, since the convolution of a separable eyelash with the Gaussian smoothing function results in a low output value. Thus, if a resultant point is smaller than a threshold, it is noted that this point belongs to an eyelash. Multiple eyelashes are detected using the variance of intensity. If the variance of intensity values in a small window is lower than a threshold, the centre of the window is considered as a point in an eyelash. The Kong and Zhang model also makes use of connective criterion, so that each point in an eyelash should connect to another point in an eyelash or to an eyelid. Specular reflections along the eye image are detected using thresholding, since the intensity values at these regions will be higher than at any other regions in the image.

3.3.2 Normalisation

The very next step once the iris region is successfully segmented from an eye image, is to transform the iris region so that it has fixed dimensions in order to allow comparisons. The dimensional inconsistencies between eye images are mainly due to the stretching of the iris caused by pupil dilation from varying levels of illumination. Other sources of inconsistency include, varying imaging distance, rotation of the camera, head tilt, and rotation of the eye within the eye socket. The normalisation process will produce iris regions, which have the same constant dimensions, so that two photographs of the same iris under different conditions will have characteristic features at the same spatial location.

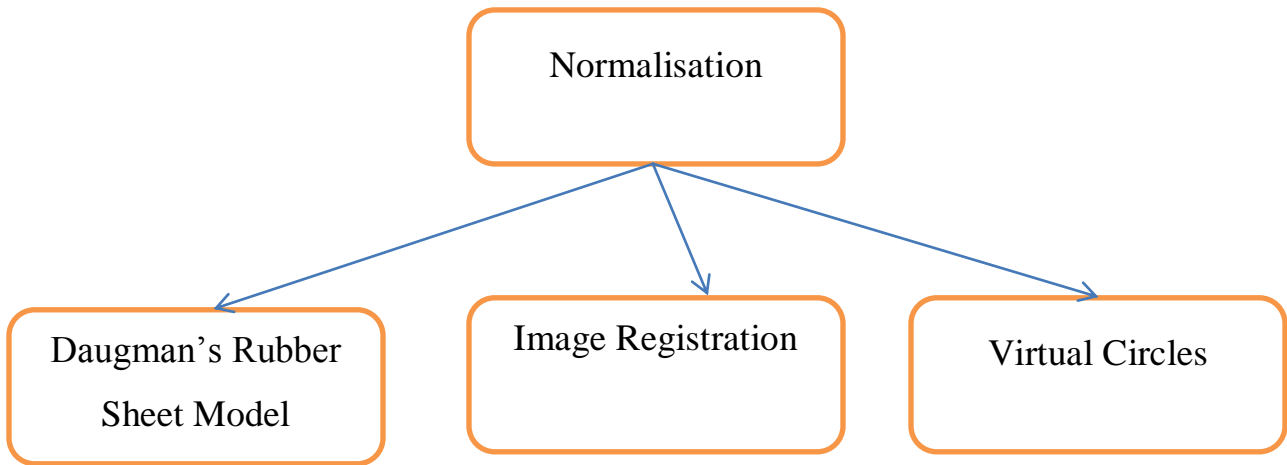

Figure3.3 : Technological Perspectives in Normalisation Module

Another point of note is that the pupil region is not always concentric within the iris region, and is usually slightly nasal. This must be taken into account if trying to normalise the ‘doughnut’ shaped iris region to have constant radius.

Daugman’s Rubber Sheet Model

The homogenous rubber sheet model devised by Daugman remaps each point within the iris region to a pair of polar coordinates (r, θ) where r is on the interval $[0,1]$ and θ is angle $[0,2\pi]$. The remapping of the iris region from (x,y) Cartesian coordinates to the normalised non-concentric polar representation is modelled as

$$I(x(r, \theta), y(r, \theta)) \rightarrow I(r, \theta) \quad 3.5$$

$$x(r, \theta) = (1 - r)x_p(\theta) + rx_l(\theta) \quad 3.6$$

$$y(r, \theta) = (1 - r)y_p(\theta) + ry_l(\theta) \quad 3.7$$

where $I(x,y)$ is the iris region image, (x,y) are the original Cartesian coordinates, (r,θ) are the corresponding normalised polar coordinates, and x_p, y_p and x_l, y_l are the coordinates of the pupil and iris boundaries along the θ direction. The rubber sheet model takes into account pupil dilation and size inconsistencies in order to produce a normalised representation with constant

dimensions. In this way the iris region is modelled as a flexible rubber sheet anchored at the iris boundary with the pupil centre as the reference point.

Even though the homogenous rubber sheet model accounts for pupil dilation, imaging distance and non-concentric pupil displacement, it does not compensate for rotational inconsistencies. In the Daugman system, rotation is accounted for during matching by shifting the iris templates in the θ direction until two iris templates are aligned.

Image Registration

The Wildes et al. system employs an image registration technique, which geometrically warps a newly acquired image, $I_a(x, y)$ into alignment with a selected database image $I_d(x, y)$ [3]. When choosing a mapping function $(u(x, y), v(x, y))$ to transform the original coordinates, the image intensity values of the new image are made to be close to those of corresponding points in the reference image. The mapping function must be chosen so as to minimise

$$\iint (I_a(x, y) - I_d(x - u, y - v))^2 dx dy \quad 3.8$$

$$\begin{pmatrix} x' \\ y' \end{pmatrix} = \begin{pmatrix} x \\ y \end{pmatrix} - sR(\phi) \begin{pmatrix} x \\ y \end{pmatrix} \quad 3.9$$

with s a scaling factor and $R(\phi)$ a matrix representing rotation by ϕ . In implementation, given a pair of iris images I_a and I_d , the warping parameters s and ϕ are recovered via an iterative minimisation procedure [3].

Virtual Circles

In the Boles [6] system, iris images are first scaled to have constant diameter so that when comparing two images, one is considered as the reference image. This works differently to the other techniques, since normalisation is not performed until attempting to match two iris regions, rather than performing normalisation and saving the result for later comparisons. Once the two irises have the same dimensions, features are extracted from the iris region by storing the intensity values along virtual concentric circles, with origin at the centre of the pupil. A normalisation resolution is selected, so that the number of data points extracted from each iris is the same. This is essentially the same as Daugman's rubber sheet model, however scaling is at

match time, and is relative to the comparing iris region, rather than scaling to some constant dimensions. Also, it is not mentioned by Boles, how rotational invariance is obtained.

3.3.3 Feature Encoding

In order to provide accurate recognition of individuals, the most discriminating information present in an iris pattern must be extracted. Only the significant features of the iris must be encoded so that comparisons between templates can be made. Most iris recognition systems make use of a band pass decomposition of the iris image to create a biometric template.

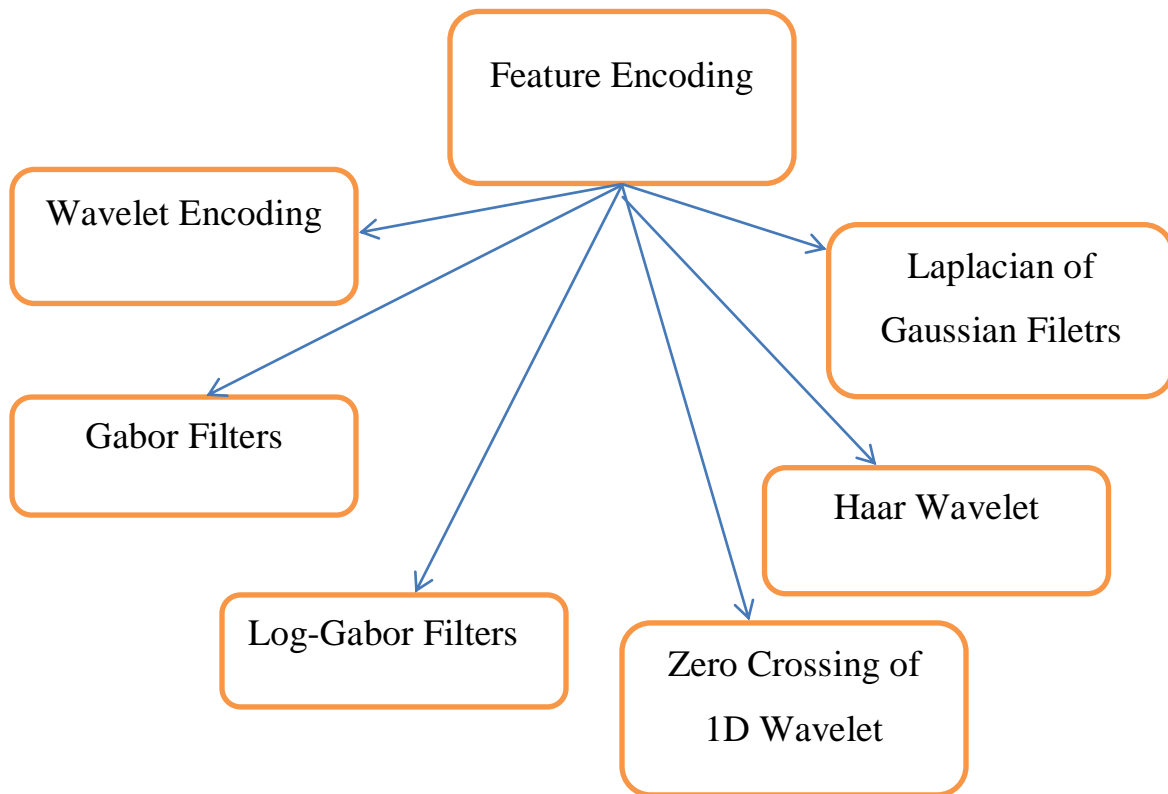

Figure 3.4: Technological Perspectives in Normalisation Module

The template that is generated in the feature encoding process will also need a corresponding matching metric, which gives a measure of similarity between two iris templates. This metric should give one range of values when comparing templates generated from the same eye, known as intra-class comparisons, and another range of values when comparing templates created from different irises, known as inter-class comparisons. These two cases should give distinct and

separate values, so that a decision can be made with high confidence as to whether two templates are from the same iris, or from two different irises.

Wavelet Encoding

Wavelets can be used to decompose the data in the iris region into components that appear at different resolutions. Wavelets have the advantage over traditional Fourier transform in that the frequency data is localised, allowing features which occur at the same position and resolution to be matched up. A number of wavelet filters, also called a bank of wavelets, is applied to the 2D iris region, one for each resolution with each wavelet a scaled version of some basis function. The output of applying the wavelets is then encoded in order to provide a compact and discriminating representation of the iris pattern.

Gabor Filters

Gabor filters are able to provide optimum conjoint representation of a signal in space and spatial frequency. A Gabor filter is constructed by modulating a sine/cosine wave with a Gaussian. This is able to provide the optimum conjoint localisation in both space and frequency, since a sine wave is perfectly localised in frequency, but not localised in space. Modulation of the sine with a Gaussian provides localisation in space, though with loss of localisation in frequency. Decomposition of a signal is accomplished using a quadrature pair of Gabor filters, with a real part specified by a cosine modulated by a Gaussian, and an imaginary part specified by a sine modulated by a Gaussian. The real and imaginary filters are also known as the even symmetric and odd symmetric components respectively. The centre frequency of the filter is specified by the frequency of the sine/cosine wave, and the bandwidth of the filter is specified by the width of the Gaussian. Daugman makes use of a 2D version of Gabor filters in order to encode iris pattern data. A 2D Gabor filter over the an image domain (x,y) is represented as

$$G(x, y) = e^{-\pi\left[\frac{(x-x_0)^2}{\alpha^2} + \frac{(y-y_0)^2}{\beta^2}\right]} e^{-2\pi i[u_0(x-x_0)+v_0(y-y_0)]} \quad 3.10$$

where (x_0, y_0) specify position in the image, (α, β) specify the effective width and length, and (u_0, v_0) specify modulation with frequency $\omega_0 = \sqrt{u_0^2 + v_0^2}$. Daugman demodulates the output of the Gabor filters in order to compress the data. This is done by quantising the phase

information into four levels, for each possible quadrant in the complex plane. It has been shown by Oppenheim and Lim [20] that phase information, rather than amplitude information provides the most significant information within an image. Taking only the phase will allow encoding of discriminating information in the iris, while discarding redundant information such as illumination, which is represented by the amplitude component.

These four levels are represented using two bits of data, so each pixel in the normalised iris pattern corresponds to two bits of data in the iris template. The Daugman system makes use of polar coordinates for normalisation, therefore in polar form the filters are given as

$$H(r, \theta) = e^{-\left[\frac{(r-r_0)^2}{\alpha^2}\right]} e^{i\frac{(\theta-\theta_0)^2}{\beta^2}} e^{-i\omega(\theta-\theta_0)} \quad 3.11$$

where (α, β) are the same as in Equation 3.10 and (r, θ) specify the centre frequency of the filter.

The demodulation and phase Quantisation process can be represented as

$$h_{\{Re, Im\}} = \text{sgn}_{\{Re, Im\}} \iint_{\rho \phi} I(\rho, \phi) e^{-i\omega(\theta_0-\phi)} e^{-\left[\frac{(r_0-\rho)^2}{\alpha^2}\right]} e^{i\frac{(\theta_0-\phi)^2}{\beta^2}} \rho d\rho d\phi \quad 3.12$$

where $h_{\{Re, Im\}}$ can be regarded as a complex valued bit whose real and imaginary components are dependent on the sign of the 2D integral, and $I(\rho, \phi)$ is the raw iris image in a dimensionless polar coordinate system. For a detailed study of 2D Gabor wavelets see [21].

Log-Gabor Filter

A disadvantage of the Gabor filter is that the even symmetric filter will have a DC component whenever the bandwidth is larger than one octave [22]. However, zero DC component can be obtained for any bandwidth by using a Gabor filter which is Gaussian on a logarithmic scale, this is known as the Log-Gabor filter. The frequency response of a Log-Gabor filter is given as;

$$G(f) = \exp\left(\frac{-\left(\log\left(\frac{f}{f_0}\right)\right)^2}{2\left(\log\left(\frac{\sigma}{f_0}\right)\right)^2}\right) \quad 3.13$$

where f_0 represents the centre frequency, and σ gives the bandwidth of the filter. Details of the Log-Gabor filter are examined by Field [22].

Zero-crossings of the 1D wavelet

Boles and Boashash [6] make use of 1D wavelets for encoding iris pattern data. The mother wavelet is defined as the second derivative of a smoothing function $\theta(x)$.

$$\psi(x) = \frac{d^2\theta(x)}{dx^2} \quad 3.14$$

The zero crossings of dyadic scales of these filters are then used to encode features.

The wavelet transform of a signal $f(x)$ at scale s and position x is given by

$$W_s f(x) = f * \left(s^2 \frac{d^2\theta(x)}{dx^2} \right) (x) \quad 3.15$$

$$= \left(s^2 \frac{d^2(f * \theta_s)}{dx^2} \right) (x) \quad 3.16$$

where $\theta_s = \frac{1}{s} \theta \left(\frac{x}{s} \right)$.

$W_s f(x)$ is proportional to the second derivative of $f(x)$ smoothed by $\theta_s(x)$, and the zero crossings of the transform correspond to points of inflection in $f * \theta_s(x)$. The motivation for this technique is that zero-crossings correspond to significant features with the iris region.

Haar Wavelet

Lim et al. [7] also use the wavelet transform to extract features from the iris region. Both the Gabor transform and the Haarwavlet are considered as the mother wavelet. Lim et al. compare the use of Gabor transform and Haar wavelet transform, and show that the recognition rate of Haar wavelet transform is slightly better than Gabor transform by 0.9%.

Laplacian of Gaussian Filters

In order to encode features, the Wildes et al. system decomposes the iris region by application of Laplacian of Gaussian filters to the iris region image. The filters are given as

$$\nabla G = -\frac{1}{\pi\sigma^4} \left(1 - \frac{\rho^2}{2\sigma^2}\right) e^{-\frac{\rho^2}{2\sigma^2}} \quad 3.17$$

where σ is the standard deviation of the Gaussian and ρ is the radial distance of a point from the centre of the filter.

The filtered image is represented as a Laplacian pyramid which is able to compress the data, so that only significant data remains. Details of Laplacian Pyramids are presented by Burt and Adelson [23]. A Laplacian pyramid is constructed with four different resolution levels in order to generate a compact iris template.

3.3.4 Matching Algorithms

Matching Algorithms are used for verification as well as Identification functions. Inter alia it is also a sensitive technological module which requires critical examination. Three algorithms which are repeatedly used in iris recognition technology discussed below are:

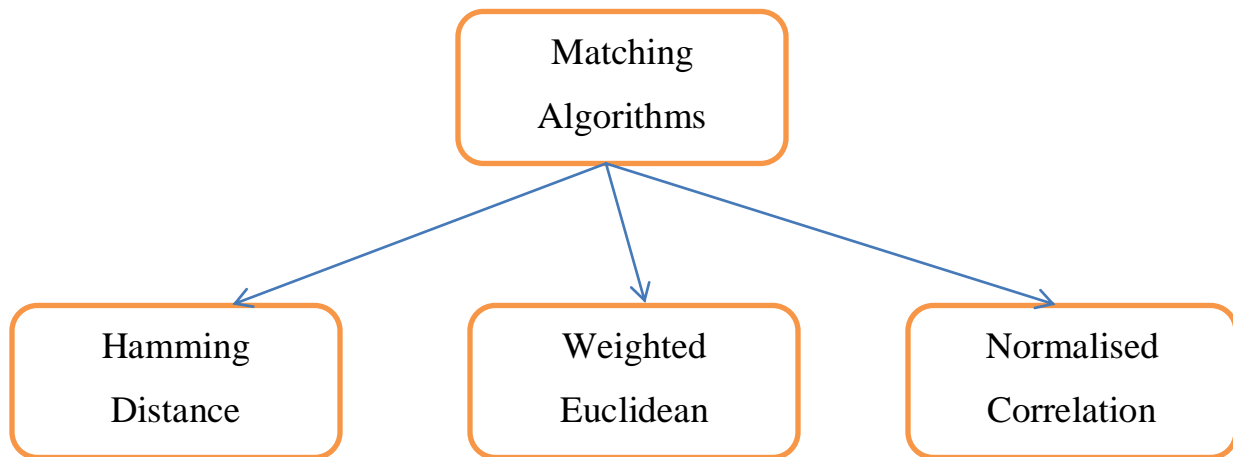

Figure 3.5 : Technological Perspectives in Normalisation Module

Hamming Distance

The Hamming distance gives a measure of how many bits are the same between two bit patterns. Using the Hamming distance of two bit patterns, a decision can be made as to whether the two patterns were generated from different irises or from the same one.

In comparing the bit patterns X and Y , the Hamming distance, HD , is defined as the sum of disagreeing bits (sum of the exclusive-OR between X and Y) over N , the total number of bits in the bit pattern.

$$HD = \frac{1}{N} \sum_{i=1}^N X_i (XOR) Y_i \quad 3.18$$

Since an individual iris region contains features with high degrees of freedom, each iris region will produce a bit-pattern which is independent to that produced by another iris, on the other hand, two iris codes produced from the same iris will be highly correlated.

If two bits patterns are completely independent, such as iris templates generated from different irises, the Hamming distance between the two patterns should equal 0.5. This occurs because independence implies the two bit patterns will be totally random, so there is 0.5 chance of setting any bit to 1, and vice versa. Therefore, half of the bits will agree and half will disagree between the two patterns. If two patterns are derived from the same iris, the Hamming distance between them will be close to 0.0, since they are highly correlated and the bits should agree between the two iris codes.

The Hamming distance is the matching metric employed by Daugman, and calculation of the Hamming distance is taken only with bits that are generated from the actual iris region.

Weighted Euclidean Distance

The weighted Euclidean distance (WED) can be used to compare two templates, especially if the template is composed of integer values. The weighting Euclidean distance gives a measure of how similar a collection of values are between two templates. This metric is employed by Zhu et al. [24] and is specified as

$$WED = \frac{1}{N} \sum_{i=1}^N (f_i - f_i^{(k)})^2 / (\delta_i^{(k)})^2 \quad 3.19$$

where f_i is the i^{th} feature of the unknown iris, and $f_i^{(k)}$ is the i^{th} feature of iris template, k , and $\delta_i^{(k)}$ is the standard deviation of the i^{th} feature in iris template k . The unknown iris template is found to match iris template k , when WED is a minimum at k .

Normalised Correlation

Wildes et al. make use of normalised correlation between the acquired and database representation for goodness of match. This is represented as

$$\sum_{i=1}^n \sum_{j=1}^m (p_1[i, j] - \mu_1)(p_2[i, j] - \mu_2) / nm\sigma_1\sigma_2 \quad 3.20$$

where p_1 and p_2 are two images of size $n \times m$, μ_1 and σ_1 are the mean and standard deviation of p_1 , and μ_2 and σ_2 are the mean and standard deviation of p_2 .

Normalised correlation is advantageous over standard correlation, since it is able to account for local variations in image intensity that corrupt the standard correlation calculation.

Justification

After discussing in details the former two questions relating to research question as well as the gap analysis between the existing work and the targeted work now its time for us to answer some of the fundamental question as what prompted us to choose this particular technology, and to analyse these type of questions in objective and substantial manner while justifying our position. First of all while analysing our very starting point as what attracted us towards biometric technology and is it really worth to work upon it, well, looking at the exigencies of time, inter alia, the population explosion, the increasing demand for government intervention on the welfare activities, increasing demand for inclusive growth and increasing societal values and outlook biometric technology is definitely a panacea.

Having studied various biometric technologies present in chapter 1, the simple justification for choosing iris recognition technology, the four most basic conditions that any biometric system must possess in order to prove last statement of immediately above paragraph are:

- Universal : The feature in question should be with every one.
- Unique : No two people have that feature alike.
- Permanent : The feature does not change and can not be changed.
- Collectable : The feature is easy to obtain and quantify with a sensor.

Method	Coded Pattern	Misidentification rate	Security	Applications
Iris Recognition	Iris Pattern	1/1,200,000	High	High-security facilities
Finger printing	Finger prints	1/1,000	Medium	Universal
Hand shape	Size, length and thickness of hands	1/700	Low	Low security facilities
Facial Recognition	Outline, shape and distribution of eyes and nose	1/100	Low	Low security facilities
Signature	Shape of letters, writing order, pen pressure	1/100	Low	Low security facilities
Voice printing	Voice characteristics	1/30	Low	Telephone service

Table 1 : Comparison of available biometric systems

This concludes chapter 3 of this thesis work after rigorous and analytical analysis of technological aspects of existing work present today. Indeed the seminal work done by various scholars, engineers and scientists have explored vast knowledge for us to move further to our next chapter which encompasses the implementation aspects of our targeted work.

Design and Implementation of Research Problem

The current part of thesis deals with more substantial questions about the design as well as implementation of research problem. For implementation part we have used mainly two tools available in *MATLAB*[®], one is MATLAB Tool and other is Image Processing Tool.

4.1 MATLAB Toolbox Description

MATLAB[®] is a high-level language and interactive environment that enables you to perform computationally intensive tasks faster than with traditional programming languages such as C, C++, and Fortran.

Key Features

- High-level language for technical computing
- Development environment for managing code, files, and data
- Interactive tools for iterative exploration, design, and problem solving
- Mathematical functions for linear algebra, statistics, Fourier analysis, filtering, optimization, and numerical integration
- 2-D and 3-D graphics functions for visualizing data
- Tools for building custom graphical user interfaces
- Functions for integrating MATLAB based algorithms with external applications and languages, such as C, C++, Fortran, Java, COM, and Microsoft[®] Excel[®]

4.2 Image Processing Toolbox Description

Image Processing Toolbox provides a comprehensive set of reference-standard algorithms and graphical tools for image processing, analysis, visualization, and algorithm development. You can perform image enhancement, image deblurring, feature detection, noise reduction, image segmentation, spatial transformations, and image registration. Many toolbox functions are multithreaded to take advantage of multicore and multiprocessor computers.

Image Processing Toolbox supports a diverse set of image types, including high dynamic range, gigapixel resolution, ICC-compliant color, and tomographic. Graphical tools let you explore an image, examine a region of pixels, adjust the contrast, create contours or histograms, and manipulate regions of interest (ROIs). With toolbox algorithms you can restore degraded images, detect and measure features, analyze shapes and textures, and adjust color balance.

Key Features

- Image enhancement, filtering, and deblurring.
- Image analysis, including segmentation, morphology, feature extraction, and measurement.
- Spatial transformations and intensity-based image registration methods.
- Image transforms, including FFT, DCT, Radon, and fan-beam projection.
- Workflows for processing, displaying, and navigating arbitrarily large images.
- Interactive tools, including ROI selections, histograms, and distance measurements.
- DICOM file import and export.

4.3 The implementation of present work

The implementation is described in sequential order defining the modules designed as well as the their positional implementation is described in detail as and when we traverse along the chapter in front of us.

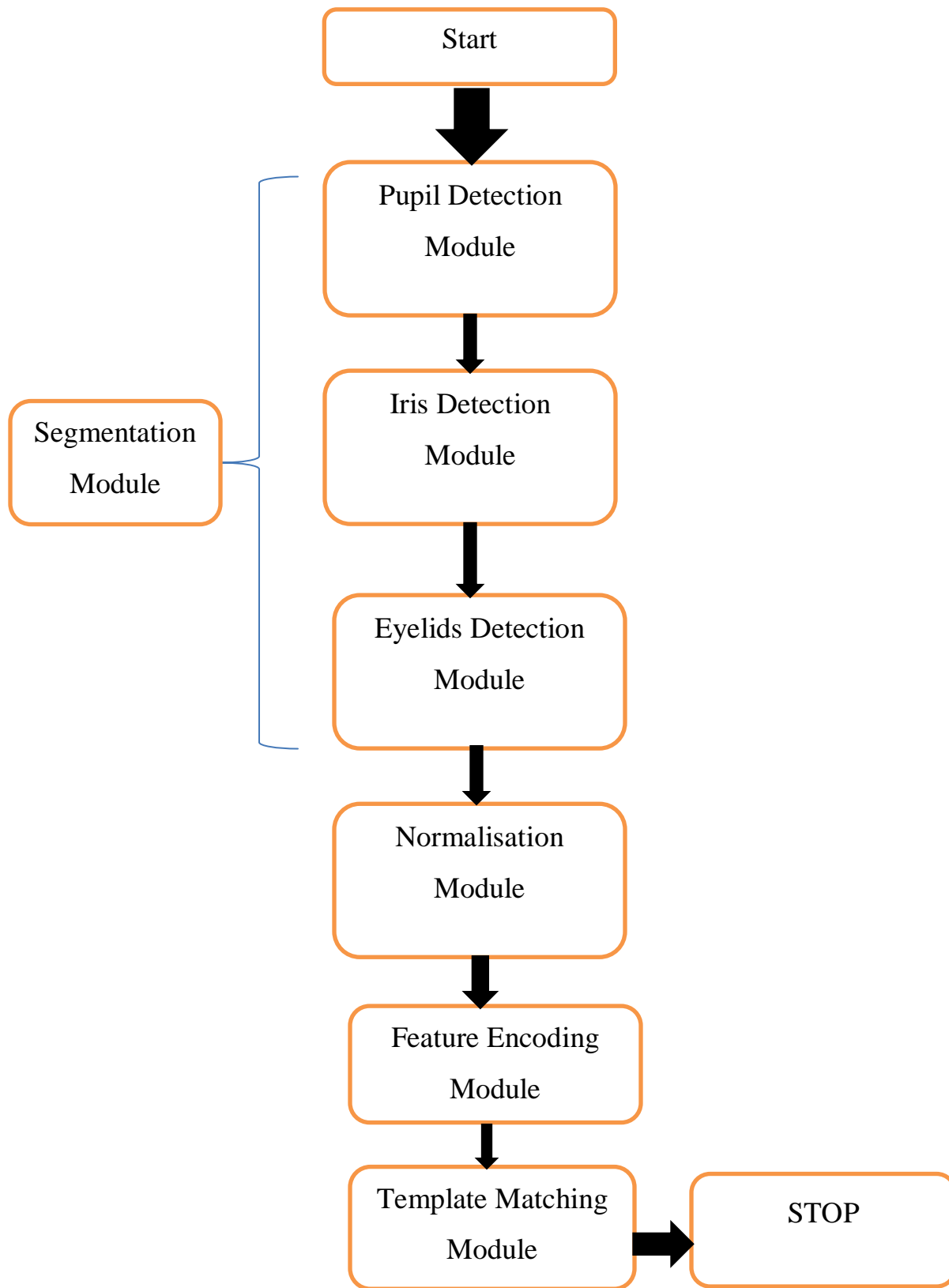

Figure 4.1 : Flowchart of implemented algorithm

1. Load Iris Image

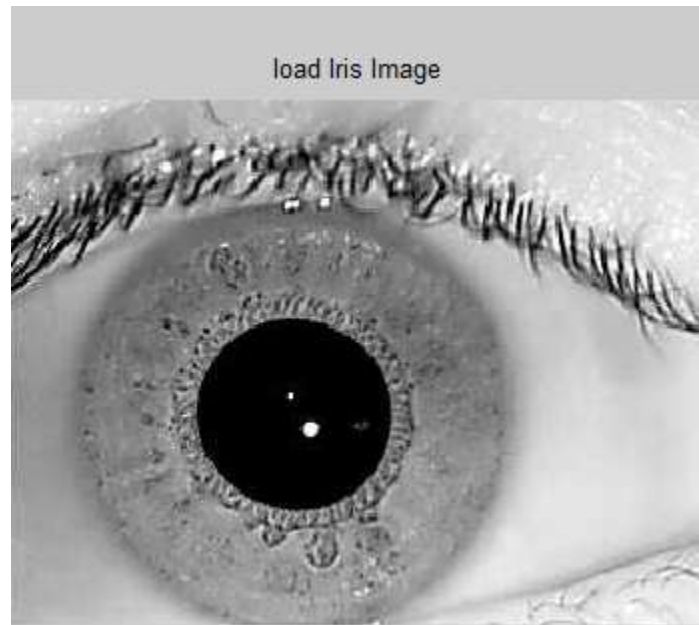

Figure 4.2 : loaded sample image of iris

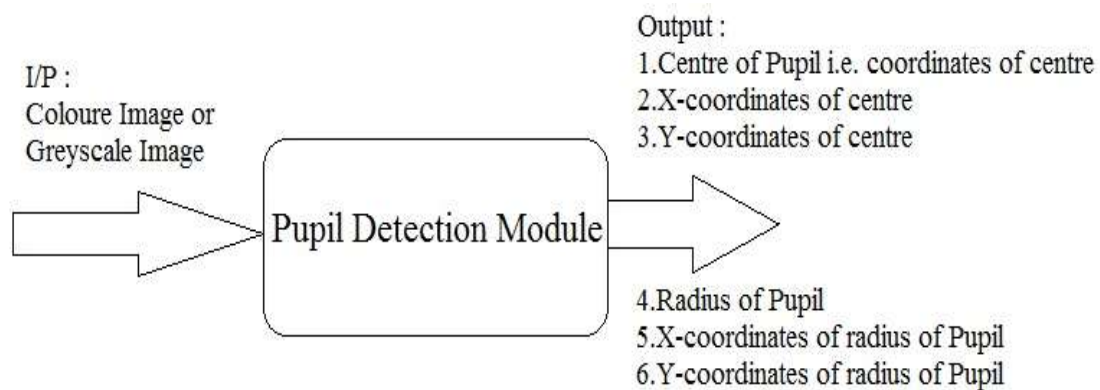

Figure4.3 : Pupil detection module

2. Convert colour image or grey image to binary image.
3. Replaces all pixels in the input image with luminance greater than level with the value 1 (white) and replaces all other pixels with the value 0 (black). Specify level in the range [0,1]. This range is relative to the signal levels possible for the image's class. Therefore, a level value of 0.5 is midway between black and white, regardless of class.
4. In our case, we have generalised the threshold limit to the half of the pixel intensity of grey scale image.
5. Create a morphological disk structuring element. A flat, disk-shaped structuring element.

6. Morphological closing on the binary image, returning the closed image. The structuring element, must be a single structuring element object, as opposed to an array of objects. The morphological close operation is a dilation followed by an erosion which help in predicting pupil, iris and sclera.
7. Morphological fill the binary image on the screen and lets you define the region to fill by selecting points interactively by using the mouse. To use this interactive syntax, image must be a 2-D image which removes the highlight present in the image.
8. Produce a binary image all connected components (objects) that have fewer than P pixels, producing another binary image.
9. Selecting a predefined threshold and employing intensity criteria loop over the boundaries.
10. Set the relevant threshold according to the data base and put the recent output image into loop to trace the exterior boundaries of objects. Image must be a binary image where nonzero pixels belong to an object and 0 pixels constitute the background.
11. Mark objects above the threshold with a black circle.
12. Isolating the pupil from image, calculate the centre and radius of pupil.

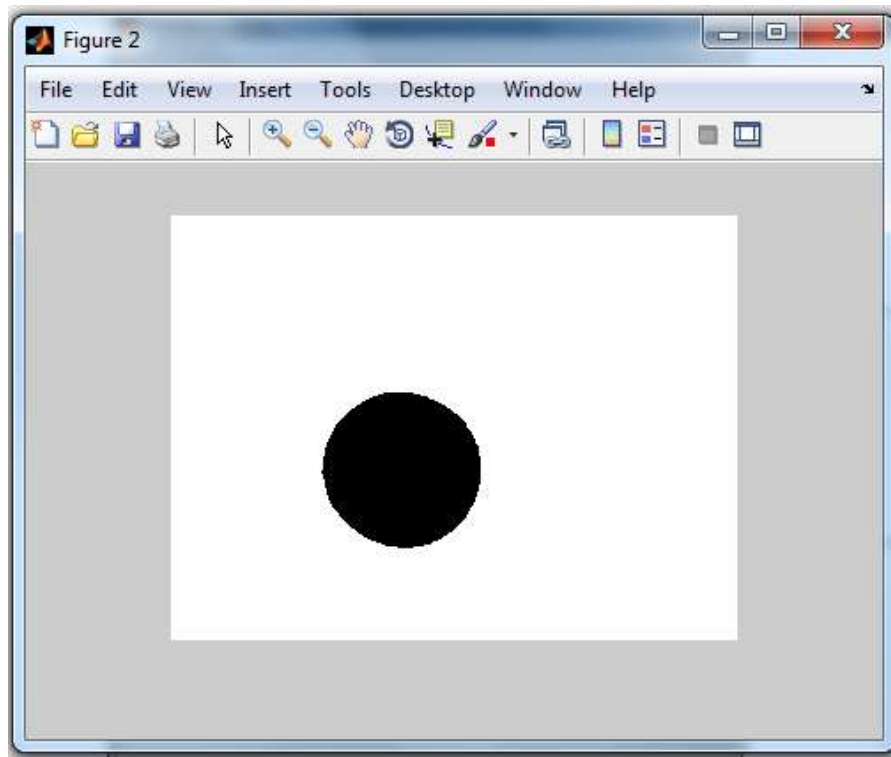

Figure 4.4 : Isolated portion of pupil from sample image

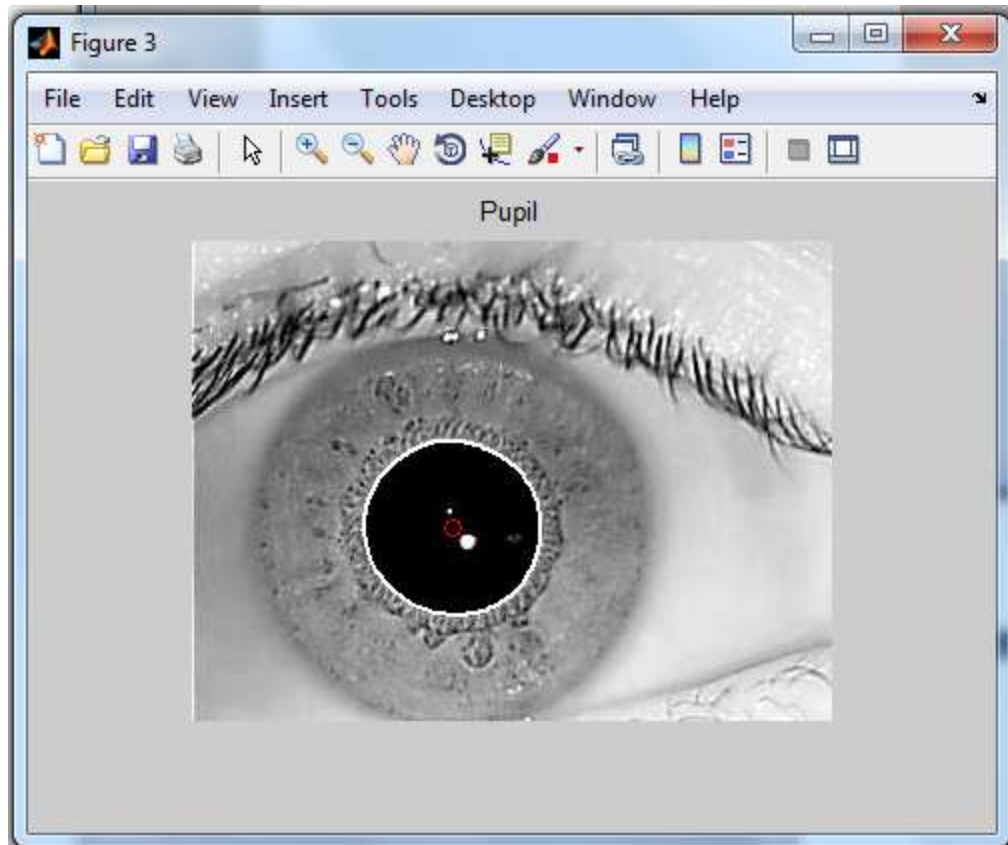

Figure 4.5 : Boundary drawn on pupil from sample image

13. The outputs achieved are then used in next module.

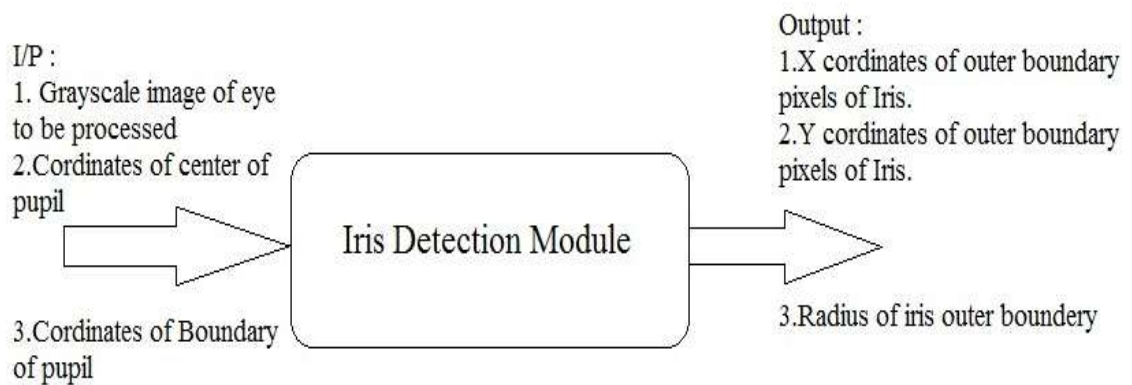

Figure4.6 : Iris detection module

14. Taking the outer most boundary coordinates into account obtained as output of pupil detection module, again put the image obtained in step 9 into loop by employing intensity criteria and the required coordinates of iris boundary having known the fact that in almost

all cases bare exceptions the intensity of sclera is more than iris, whose intensity in turn is greater than pupil's.

15. These boundary coordinates when operationalized along with the centre of pupil gives the radius of iris.

16. Thus iris boundary is drawn.

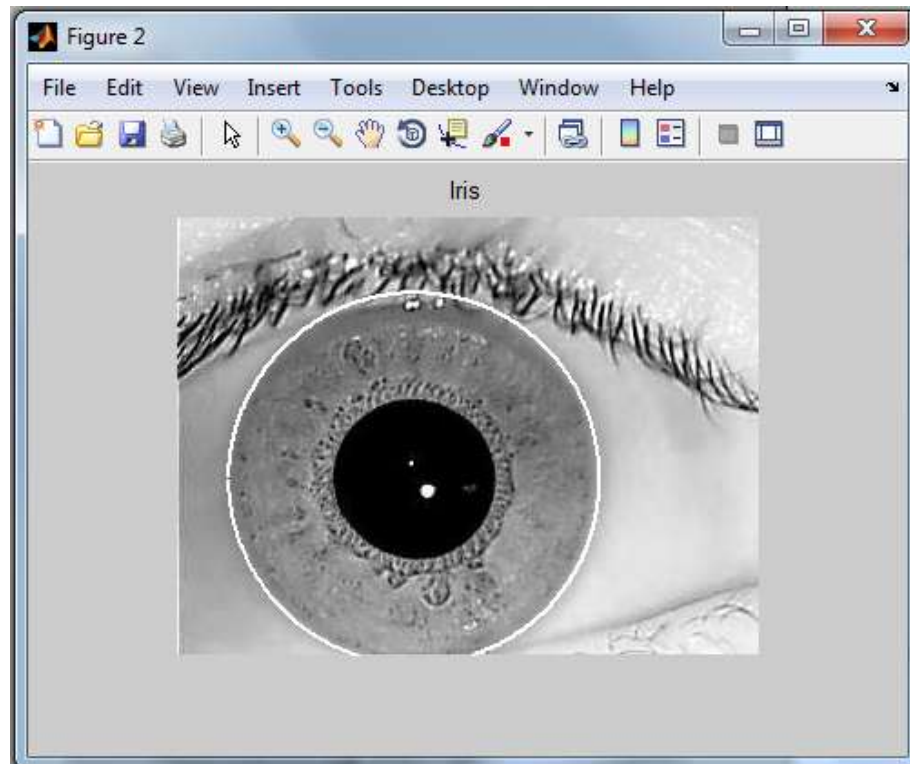

Figure 4.7 : Boundary drawn on iris from sample image

17. The outputs obtained in previous two modules is taken in account as input to the next level of module called eyelid detection module to obtain a noise free iris portion of the image.

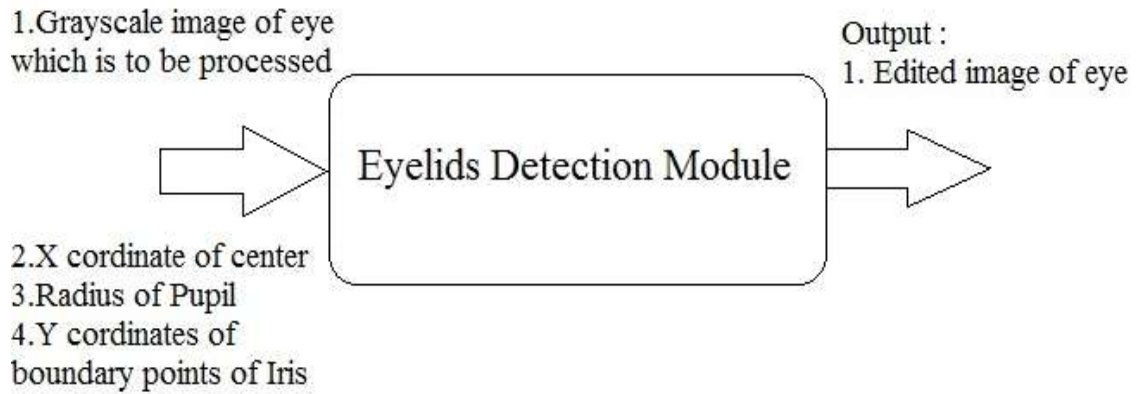

Figure 4.8 : Eyelids detection module

18. The eyelids are modeled as lines.
19. After calculating the extreme points on each direction of the image and applying radon transform we convert every eyelid pixel into a zero intensity black pixel thus mitigating the possibility of noise in iris portion.

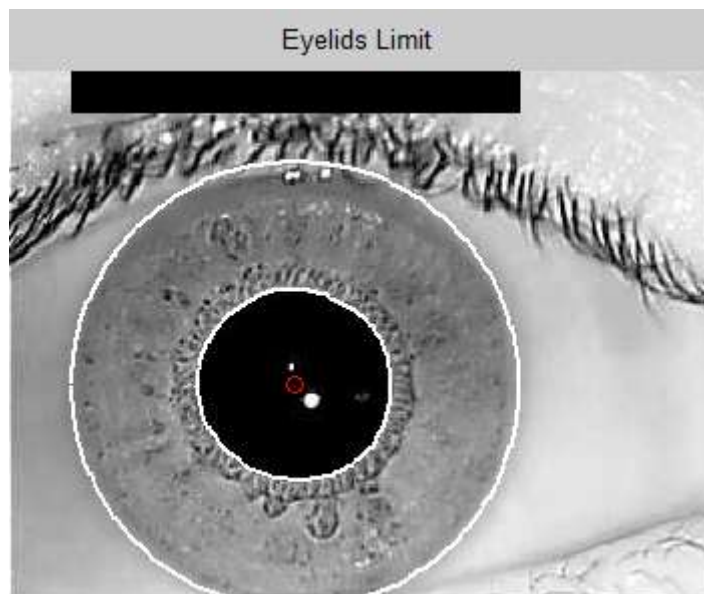

Figure 4.9 : Boundary drawn on pupil and iris from sample image

20. Now the segmentation reaches its culmination where we subtract the pupil circle from its exterior iris circle thus obtaining only iris portion.
21. At this stage we have a circular portion of a tube like structure of only iris portion from the original image which is devoid of noise due to step 18.
22. From here iris starts its journey for the process of normalisation.

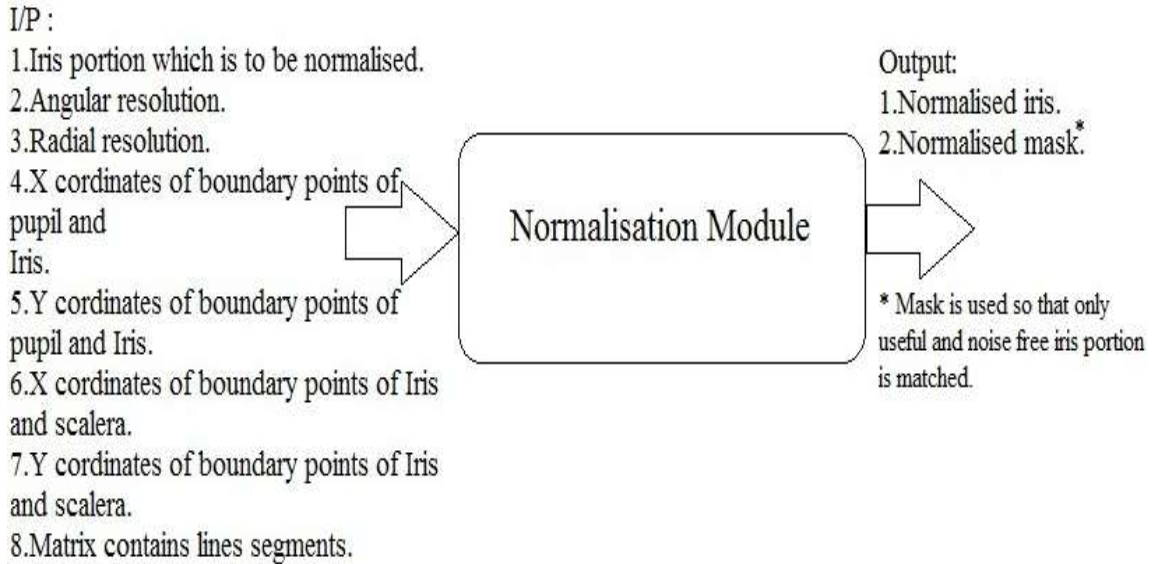

Figure 4.10 : Normalisation module

23. The centre of the pupil was considered as the reference point, and radial vectors pass through the iris region. A number of data points are selected along each radial line and this is defined as the radial resolution.
24. The number of radial lines going around the iris region is defined as the angular resolution. Since the pupil can be non-concentric to the iris, a remapping formula is needed to rescale points depending on the angle around the circle.
25. A constant number of points are chosen along each radial line, so that a constant number of radial data points are taken, irrespective of how narrow or wide the radius is at a particular angle. The normalised pattern was created by backtracking to find the Cartesian coordinates of data points from the radial and angular position in the normalised pattern. From the iris region, normalisation produces a 2D array with horizontal dimensions of angular resolution and vertical dimensions of radial resolution.
26. A normalised mask corresponding to normalised iris pattern is generated in such a way that relevant iris data is represented by zero and noise is represented by one in mask template.

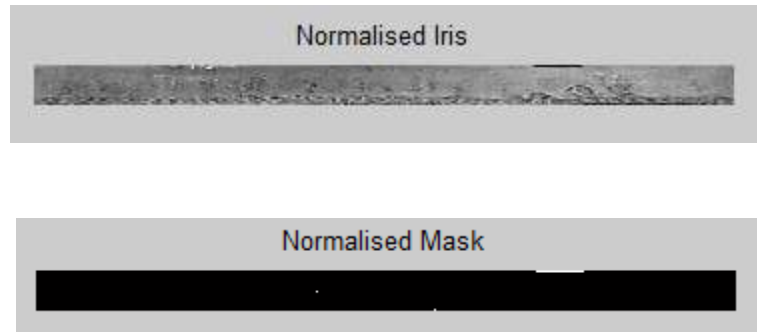

Figure 4.11 : Normalised iris and mask of sample image.

27. In order to generate the unique pattern corresponding to unique feature characteristics of normalised iris image we need to encode the normalised iris image.

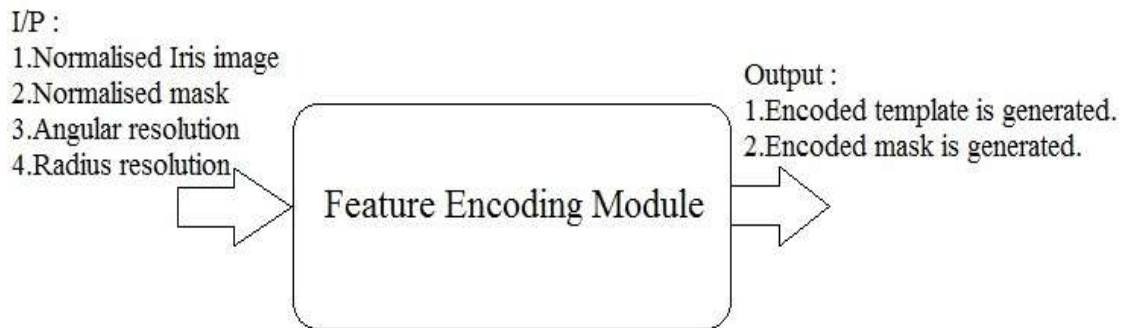

Figure 4.12 : Feature encoding module.

28. First we create a 2D-Gabor filter.

29. Transform the normalised image into to frequency domain.

30. Take Convolution of normalized Iris Image & 2D Gabor Filter.

31. The rows of the 2D normalised pattern are taken as the 1D signal, each row corresponds to a circular ring on the iris region. The angular direction is taken rather than the radial one, which corresponds to columns of the normalised pattern, since maximum independence occurs in the angular direction.

32. Transform the convoluted output back to spatial domain.

33. Demodulation & quantised of the phase information is performed.

34. Phase quantisation is performed as :

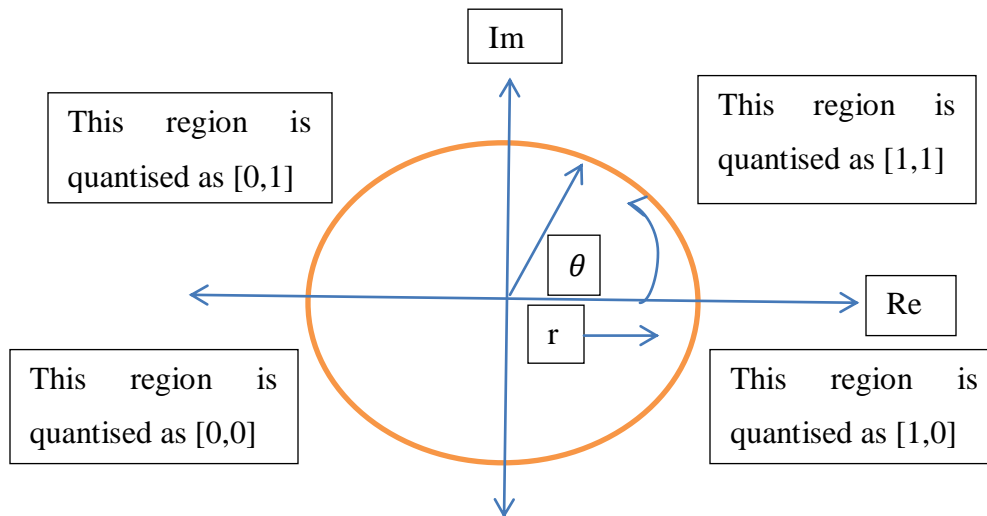

Figure 4.13: Quantisation process employed in template generating module.

35. The encoding process produces a bitwise template containing a number of bits of information, and a corresponding noise mask which corresponds to corrupt areas within the iris pattern, and marks bits in the template as corrupt.
36. Since the phase information will be meaningless at regions where the amplitude is zero, these regions are also marked in the noise mask.
37. The total number of bits in the template will be the angular resolution times the radial resolution, times 2, times the number of filters used.

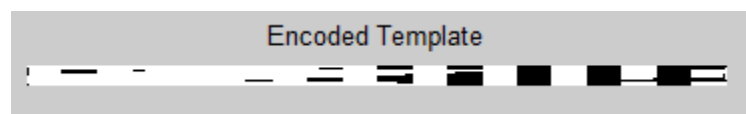

Figure 4.14 : Encoded template of sample image

38. Thus the generated template is stored in data base for implementation.
39. After culmination of three basic building blocks viz. segmentation, normalisation, feature encoding the next building block which in itself is a complementary part of every biometric system, is matching.

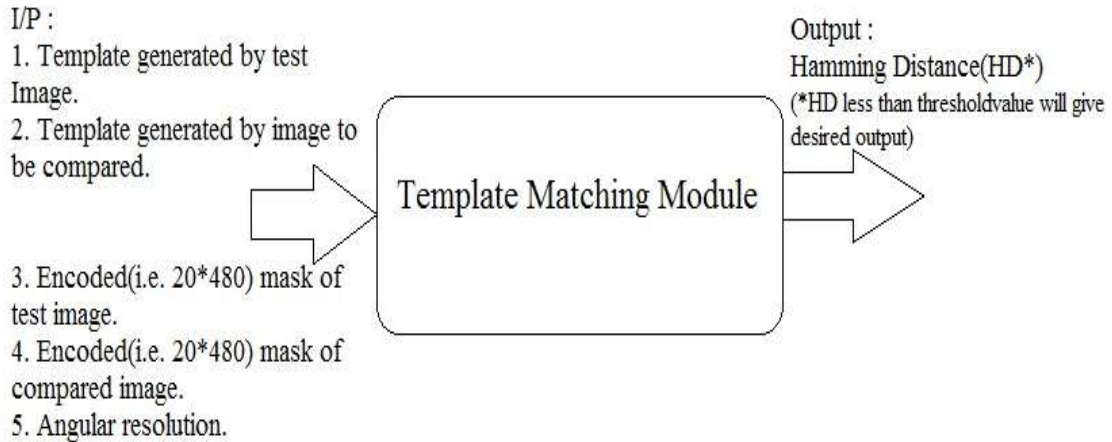

Figure 4.15 : Template matching module

40. Matching module's first task is to convert the templates and masks into logical class so that Hamming distance could be calculated.
41. For matching, the Hamming distance was chosen as a metric for recognition, since bit-wise comparisons were necessary. The Hamming distance algorithm employed also incorporates noise masking, so that only significant bits are used in calculating the Hamming distance between two iris templates.

Now when taking the Hamming distance, only those bits in the iris pattern that correspond to '0' bits in noise masks of both iris patterns will be used in the calculation. The Hamming distance will be calculated using only the bits generated from the true iris region, and this modified Hamming distance formula is given as

$$HD = \frac{1}{N - \sum_{k=1}^N Xn_k(OR)Yn_k} \sum_{j=1}^N X_j(XOR)Y_j(AND)Xn'_j(AND)Yn'_j \quad 4.4$$

42. Predefining an approximately reliable value we compare the templates with hamming distance calculated in above step.
43. If the Hamming distance thus obtained is less than threshold the "Match Found" result is shown else "No Match Found" is displayed.

This step culminates the above algorithm in the implementation of our work.

Experimental Results

This part of thesis is to mainly discuss about the results obtained on the implementation of our research problem. Gibson[41] always stressed that one must understand the nature of the environment before one can understand the nature of visual processing. However, his comments have gone largely unheeded in the mainstream of vision research. There seems to be a belief that images from the natural environment vary so widely from scene to scene that a general description would be impossible. Thus an analysis of such images is presumed to give little insight into visual function. Daugman points out that the Gabor code represents an effective means of filling the information space with functions that extend in both space and frequency. However, this does not necessarily imply that such a code must be an efficient means of representing the information in any image. As we shall see, the efficiency of a code will depend on the statistics of the input (i.e., the images). The definition of an efficient, or optimal, code depends on two parameters: the goal of the code and the statistics of the input.

As our goal is to study and implement the iris recognition technology with an alternative approach. Our alternative approach implemented the algorithm in MATLAB[®] code, is based on two assumed premises:

1. The intensity of brightness of sclera is greater than iris, whose intensity if brightness is in turn greater than pupil.
2. Iris and pupil are concentric.

Due to these two assumptions we need not to isolate the iris part as done in various research studies rather we find pupil and its coordinates which then helps us to locate iris region. We have shown the results of those images which comprehensively judges the conditions including the characteristic features of input image inter alia. Every first image in result modules represent our best performance as when we compare characteristic features of our first image with others we find considerable difference in image quality but the catch is that for most of images taken we have got such technical results which are relevant to our above assumptions. Outputs or

results are arranged in modules as discussed in previous chapter and are shown in sequential manner below:

Firstly we form a database by saving the sample images available from IIT Delhi database site[42].

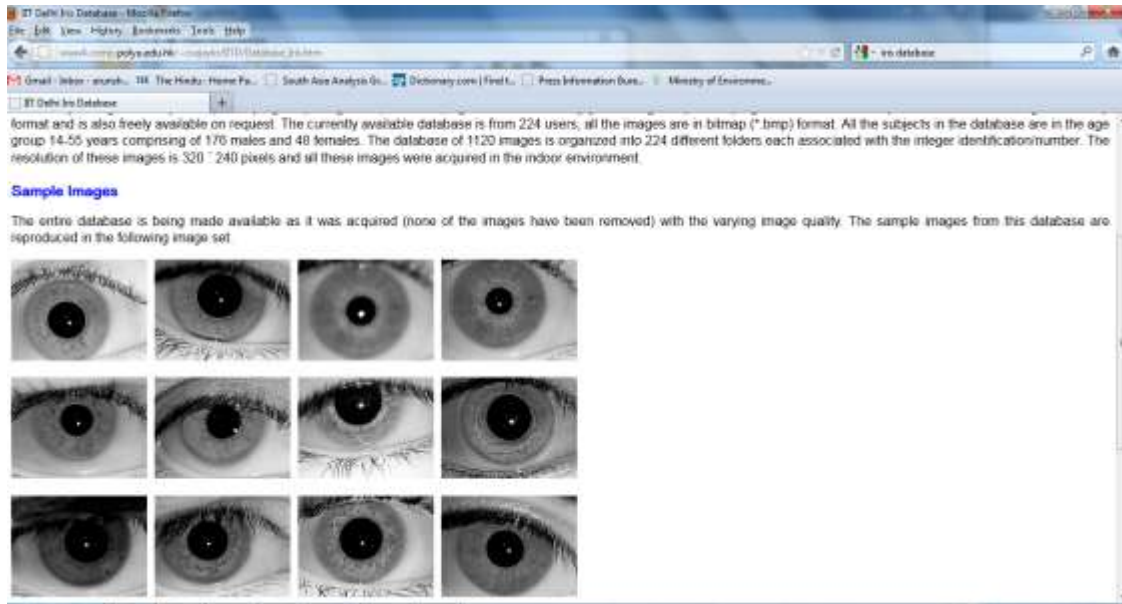

Figure 5.1 : Sample images available on IIT Delhi website

Then the available sample images are loaded and worked upon as:

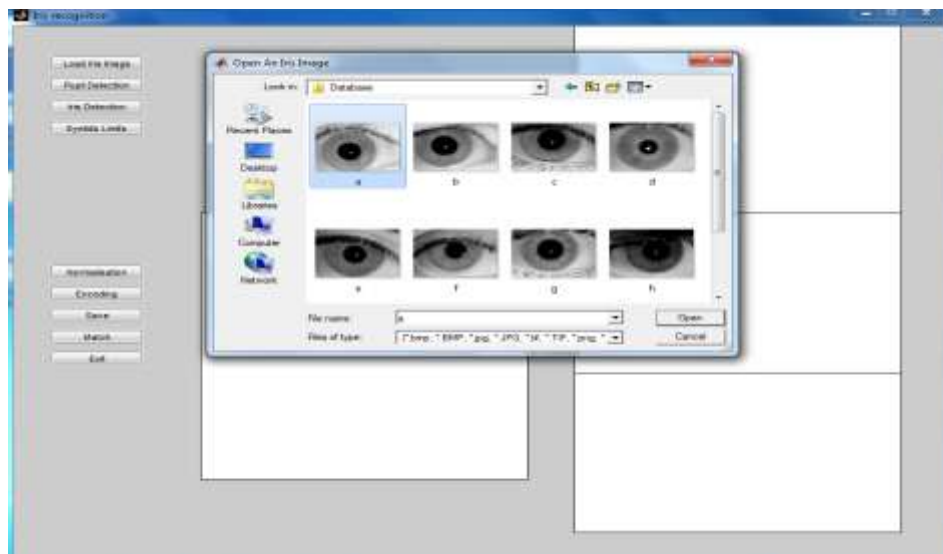

Figure 5.2 : GUI of image loading step.

After loading the image this part of the chapter deals with pupil detection module. A set of nine sample images all different to each other in their features. First five sample images show pupil detection with success while next four images show error as shown in last image of this module. The error is due to the fact that in present work we have used the image processing module detecting the set of pixels with approximately representing a circular region while in last four images as the pixels representing eyelashes and pupil are mingled together, it takes the view of a semicircle attached with an arc shape portion above it.

5.1 Pupil Detection Module

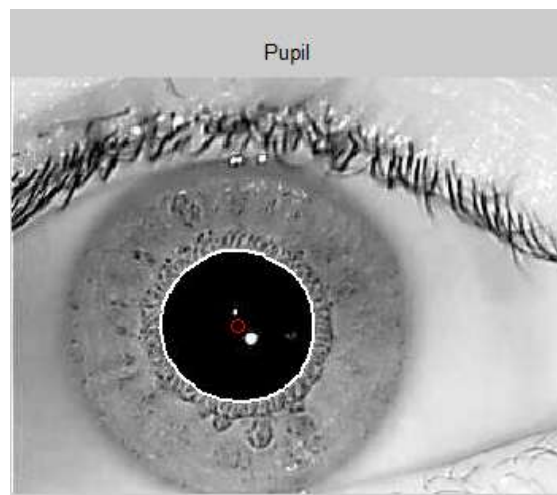

Figure 5.3 : Pupil detection (sample image 1)

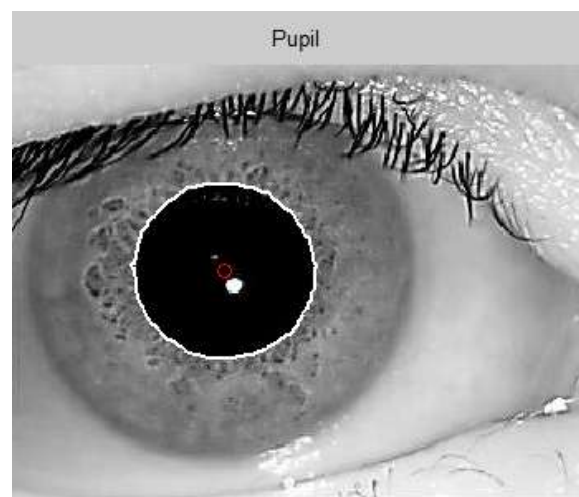

Figure 5.4 : Pupil detection (sample image 2)

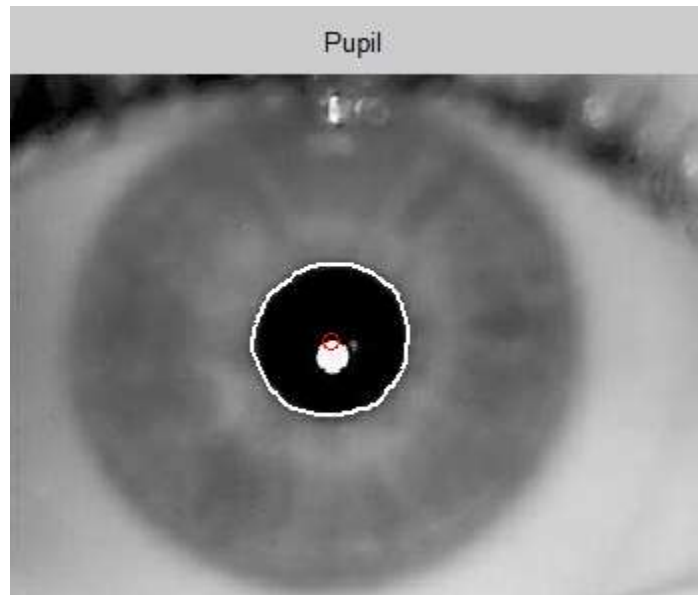

Figure 5.5 : Pupil detection (sample image 3)

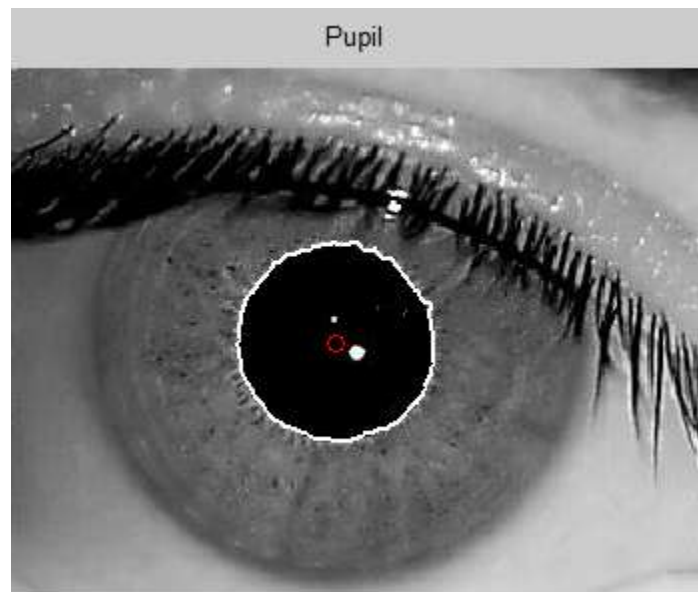

Figure 5.6 : Pupil detection (sample image 4)

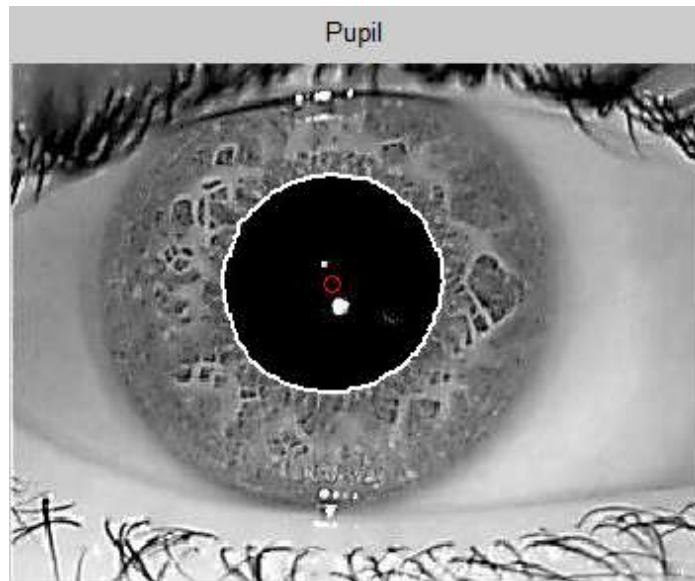

Figure 5.7 : Pupil detection (sample image 5)

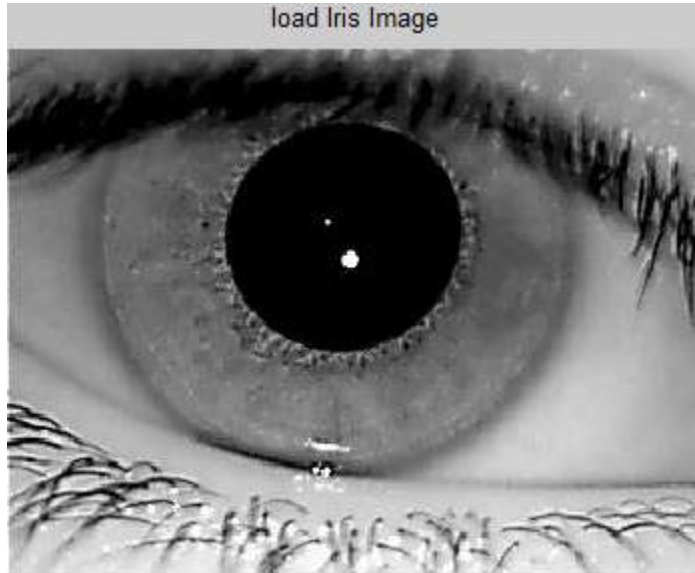

Figure 5.8 : Pupil detection (sample image 6)

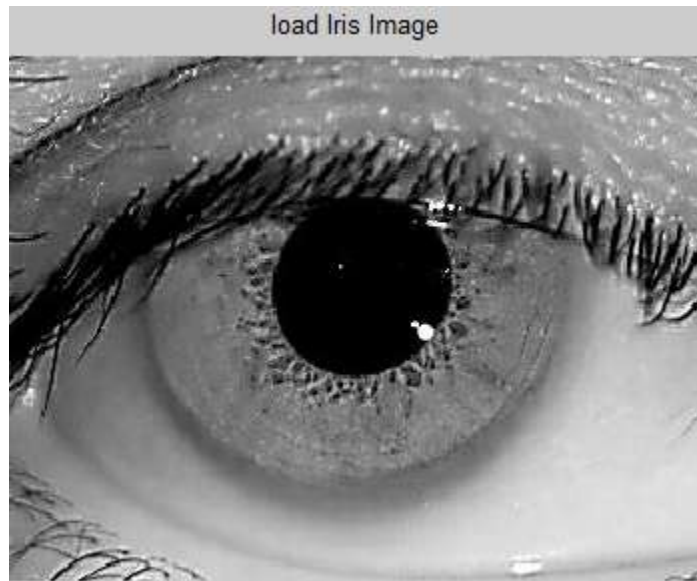

Figure 5.9 : Pupil detection (sample image 7)

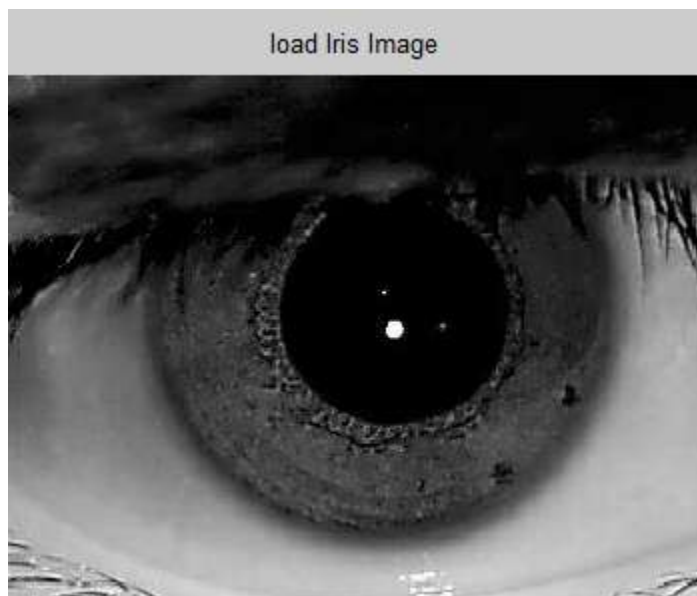

Figure 5.10 : Pupil detection (sample image 8)

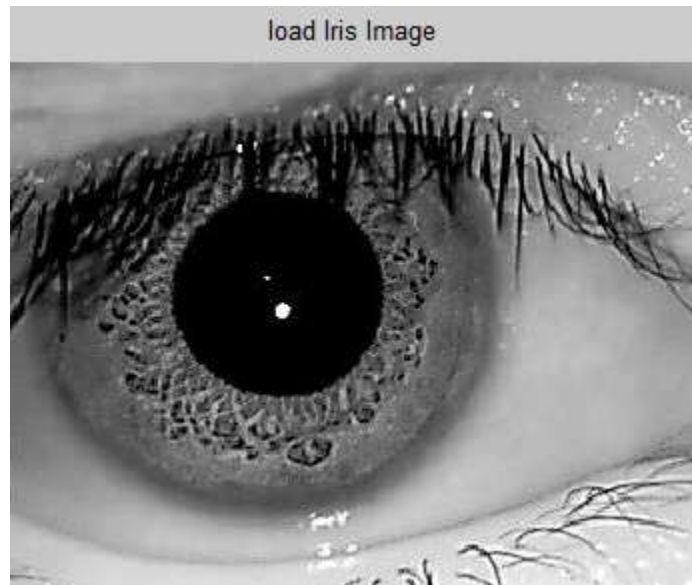

Figure 5.11 : Pupil detection (sample image 9)

```
Command Window
Undefined function or variable "center_pupil".

Error in my_pupil_detection (line 54)
if ~isempty(center_pupil)

Error while evaluating uicontrol Callback

Undefined function or variable "center_pupil".

Error in my_pupil_detection (line 54)
if ~isempty(center_pupil)

Error while evaluating uicontrol Callback

fx >> |
Start
```

Figure 5.12 : Error occurred in pupil detection for sample image 6,7,8,9.

5.2 Iris Detection Module

In Iris detection module we examined the sample images for which the corresponding detected iris region is as follows:

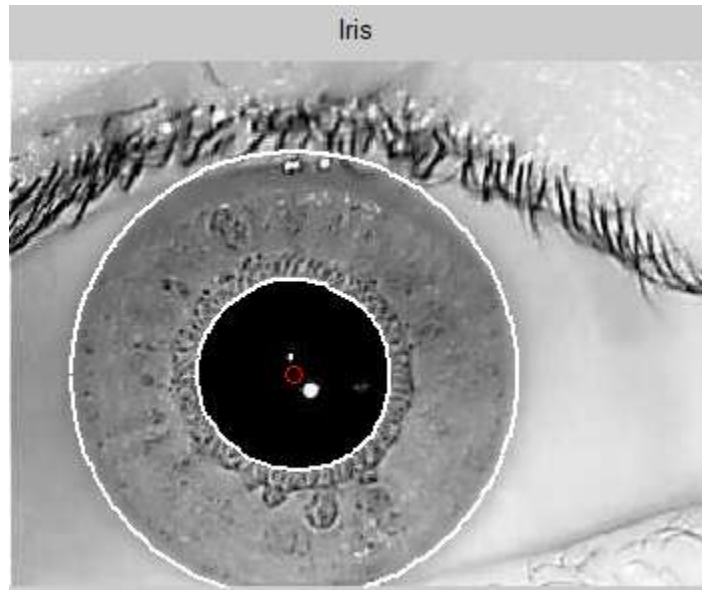

Figure 5.13 : Iris detection (sample image 1)

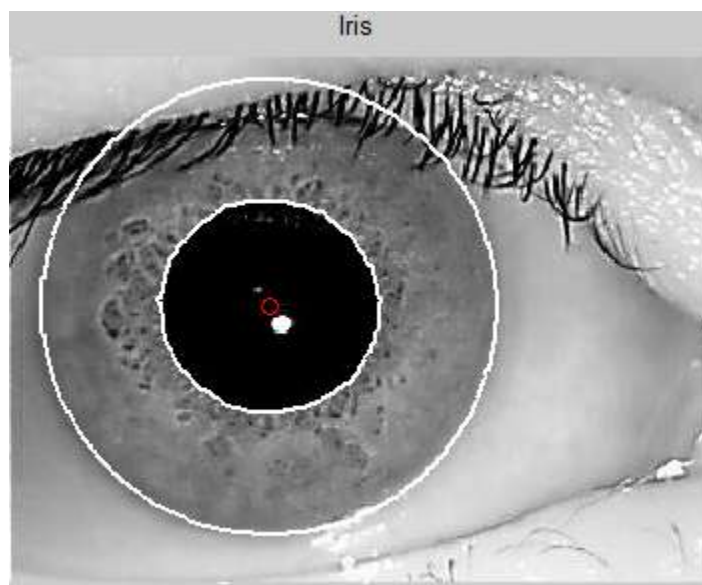

Figure 5.14 : Iris detection (sample image 2)

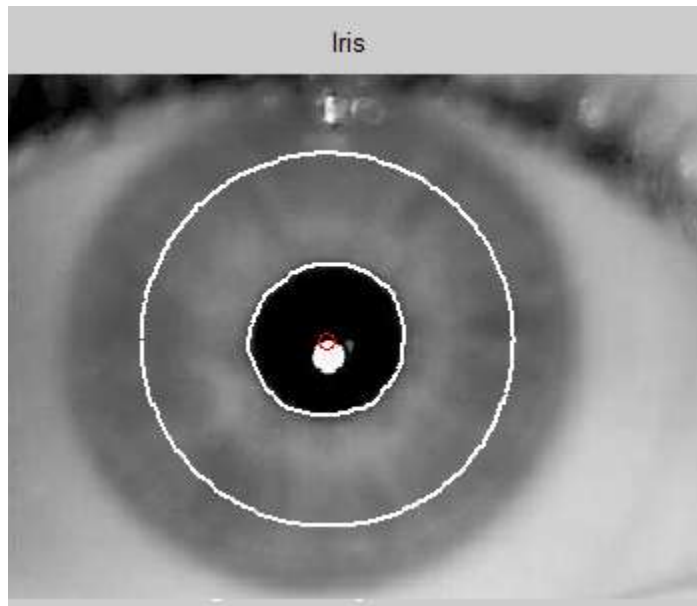

Figure 5.15 : Iris detection (sample image 3)

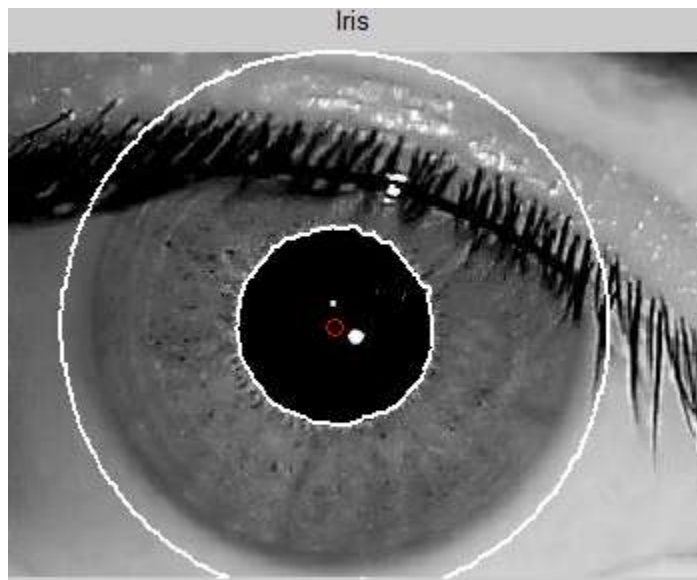

Figure 5.16 : Iris detection (sample image 4)

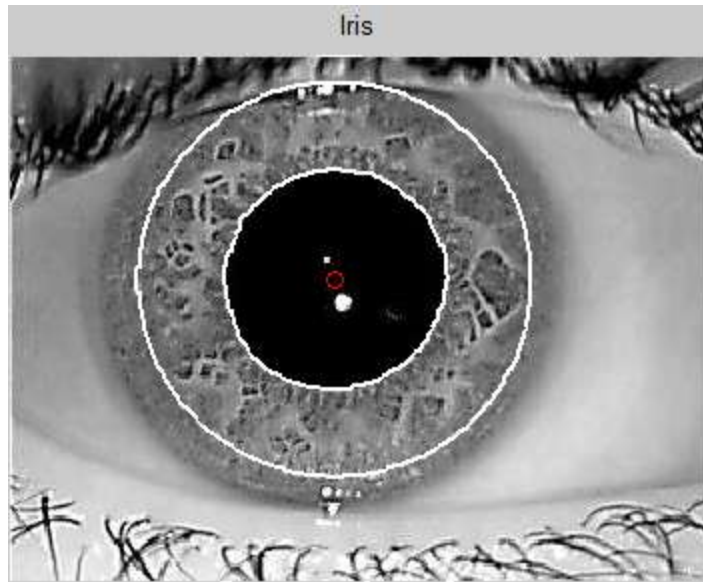

Figure 5.17 : Iris detection (sample image 4)

The eyelid detection module gives corresponding results as follows:

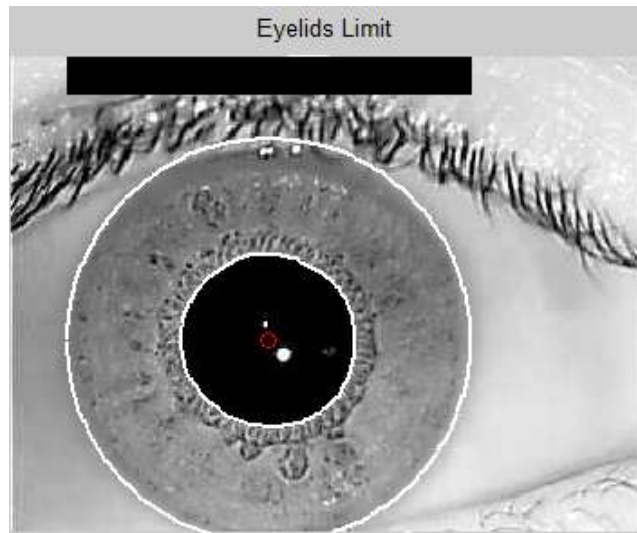

Figure 5.18 : Eyelids detection (sample image 1)

5.3 Eyelid Detection Module

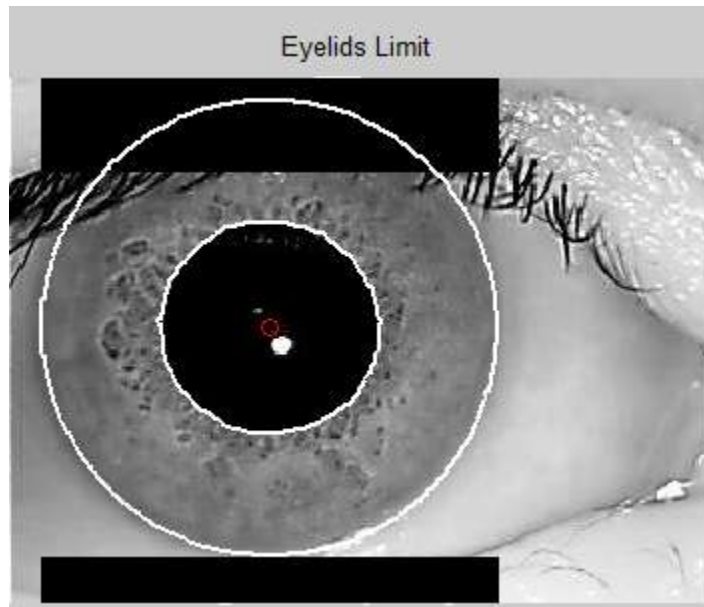

Figure 5.19 : Eyelids detection (sample image 2)

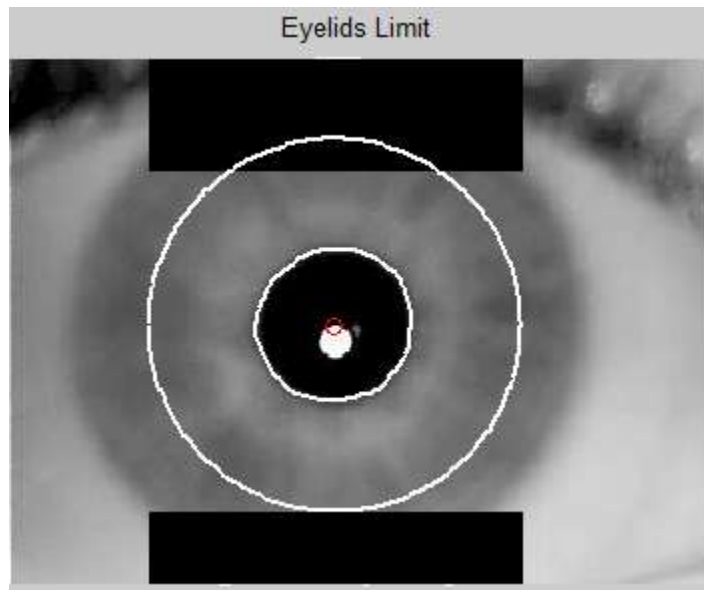

Figure 5.20 : Eyelids detection (sample image 3)

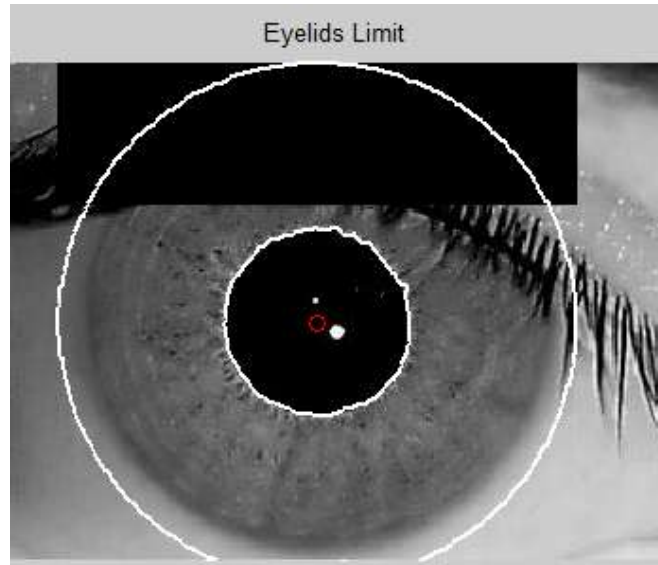

Figure 5.21 : Eyelids detection (sample image 4)

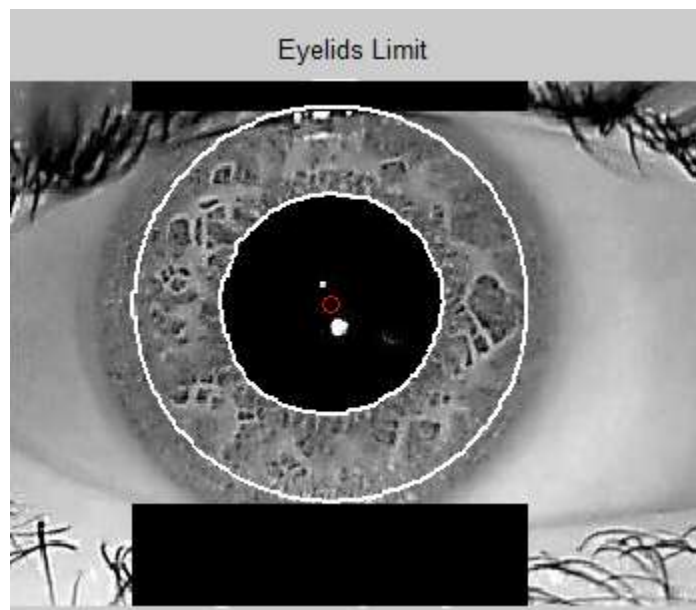

Figure 5.22 : Eyelids detection (sample image 5)

5.4 Normalisation Module

Corresponding Normalised iris and its normalised mask are shown below:

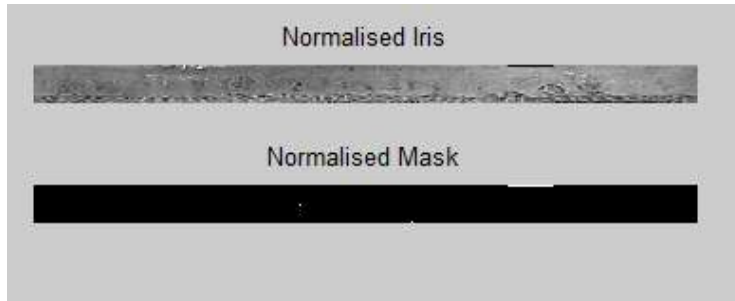

Figure 5.23 : Normalised iris and normalised mask (sample image 1)



Figure 5.24 : Normalised iris and normalised mask (sample image 2)

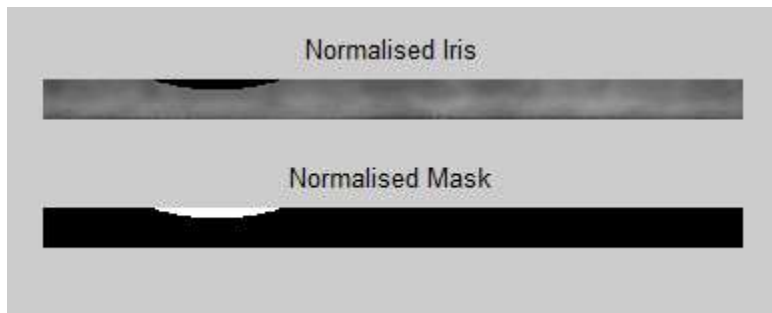

Figure 5.25 : Normalised iris and normalised mask (sample image 3)

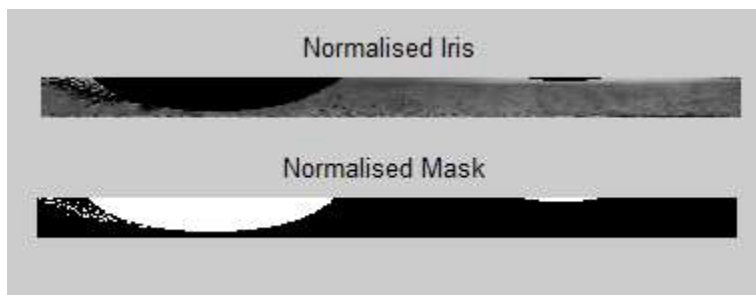

Figure 5.26 : Normalised iris and normalised mask (sample image 4)

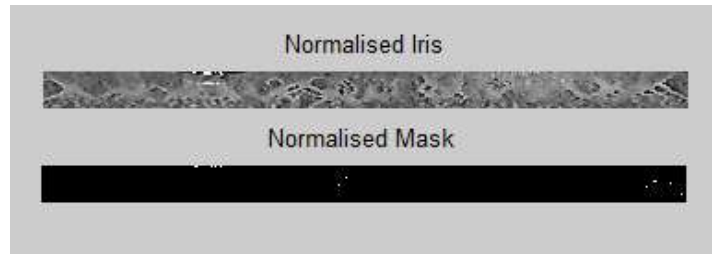

Figure 5.27 : Normalised iris and normalised mask (sample image 5)

5.5 Feature Encoding Module

The corresponding encoded templates are:

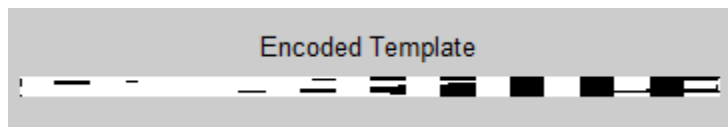

Figure 5.28 : Encoded template of iris region (sample image 1)

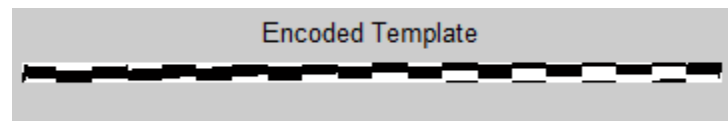

Figure 5.29 : Encoded template of iris region (sample image 2)

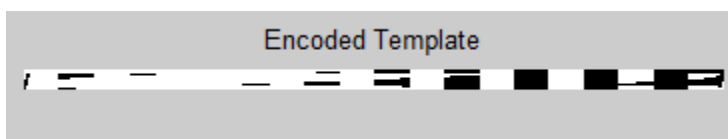

Figure 5.30 : Encoded template of iris region (sample image 3)

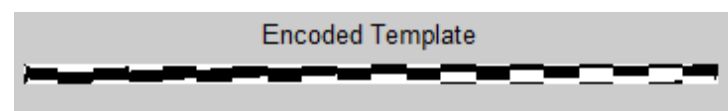

Figure 5.31 : Encoded template of iris region (sample image 4)

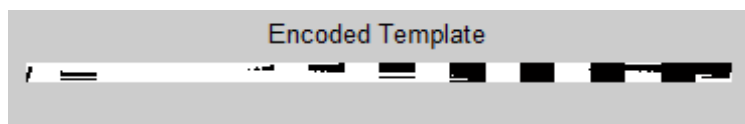

Figure 5.32 : Encoded template of iris region (sample image 5)

5.6 Results and Output in running manner

Now the matching module compares the generated template of one iris image with other and give the results correspondingly :

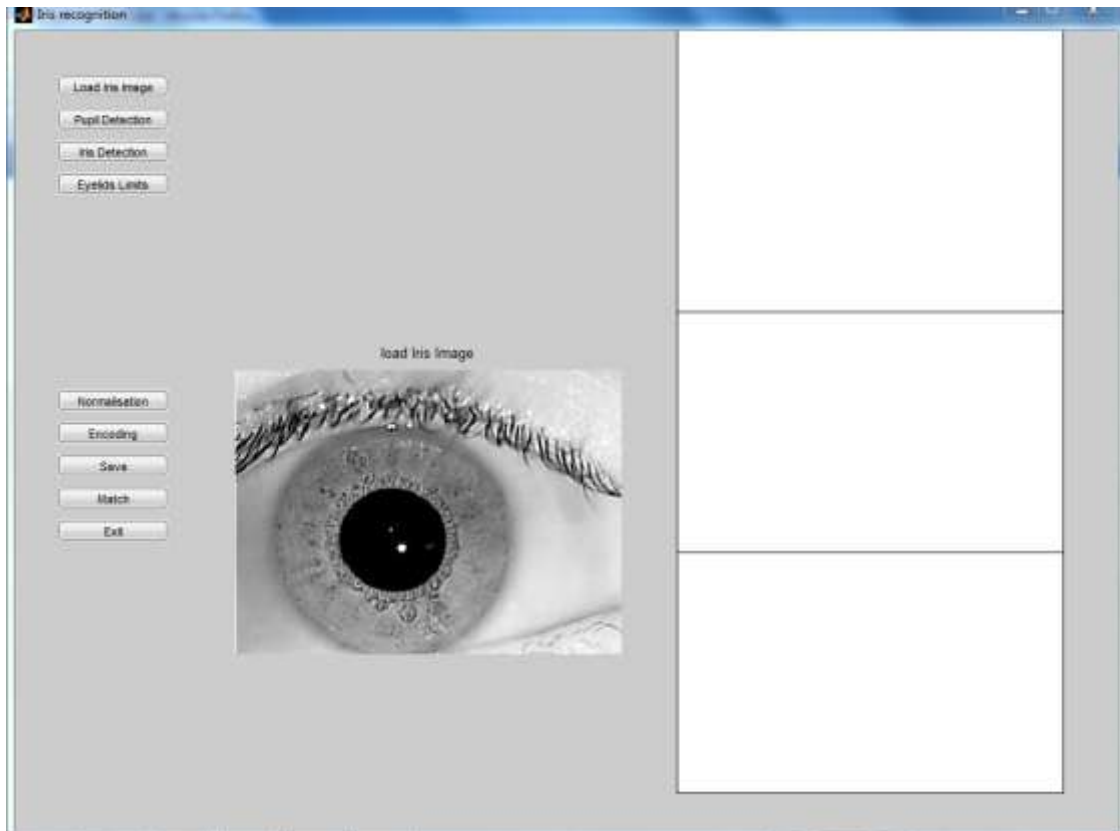

Figure 5.33 : Loaded view of sample image

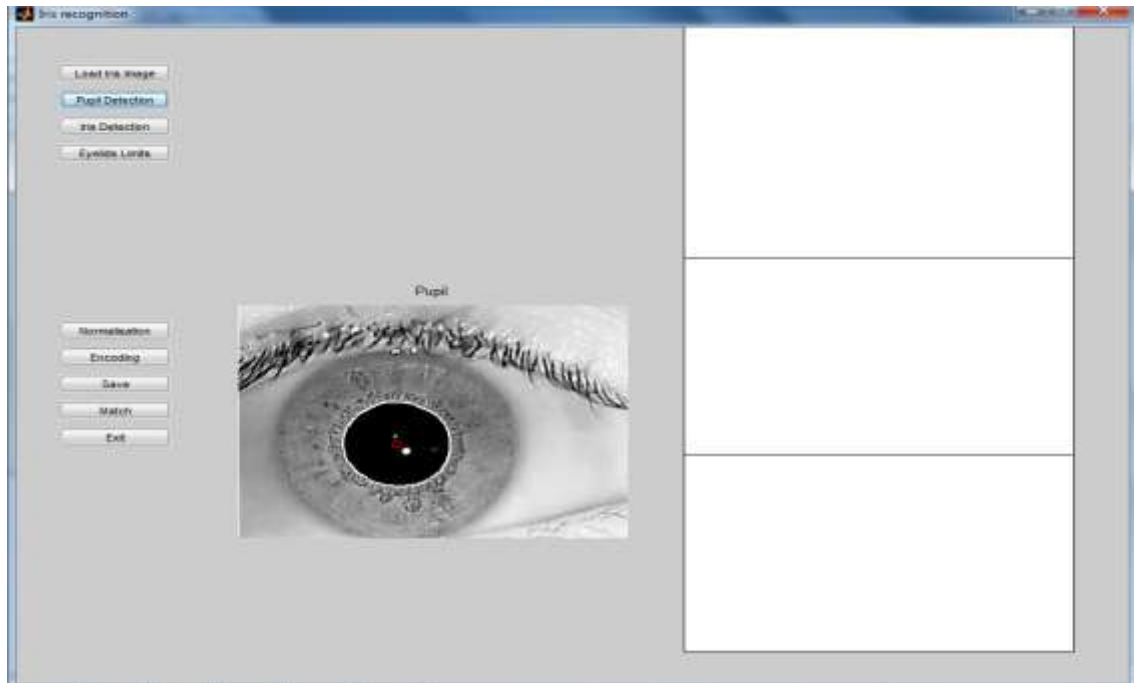

Figure 5.34 : Pupil detection

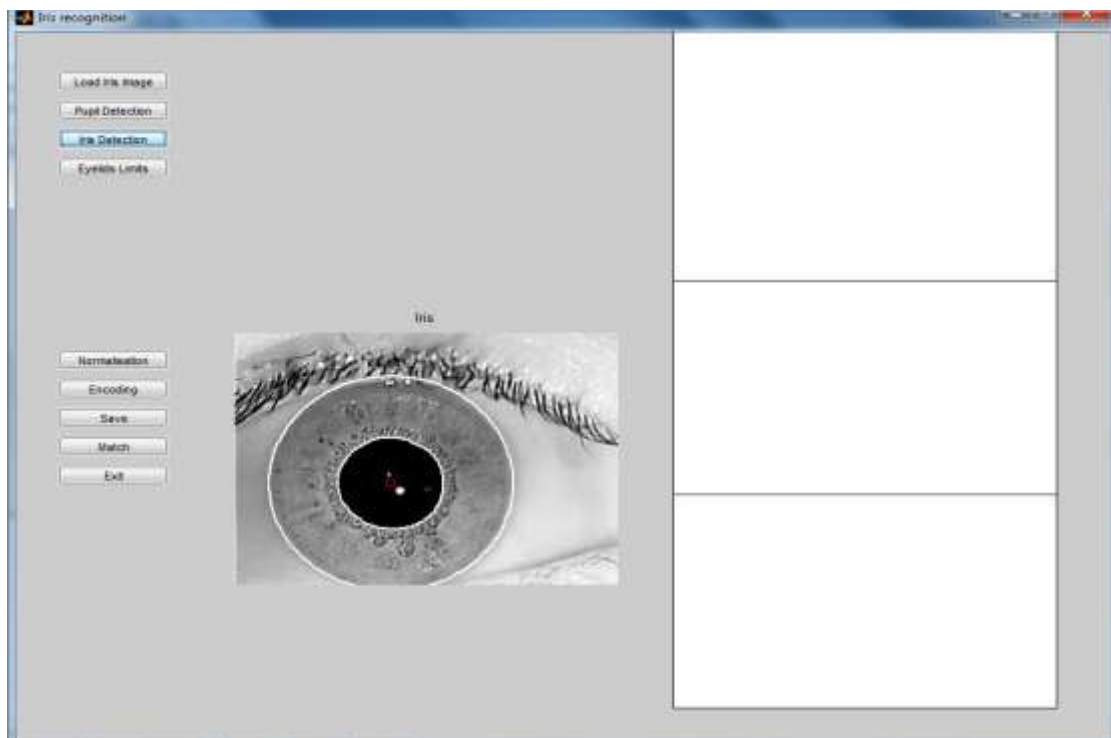

Figure 5.35 : Iris detection

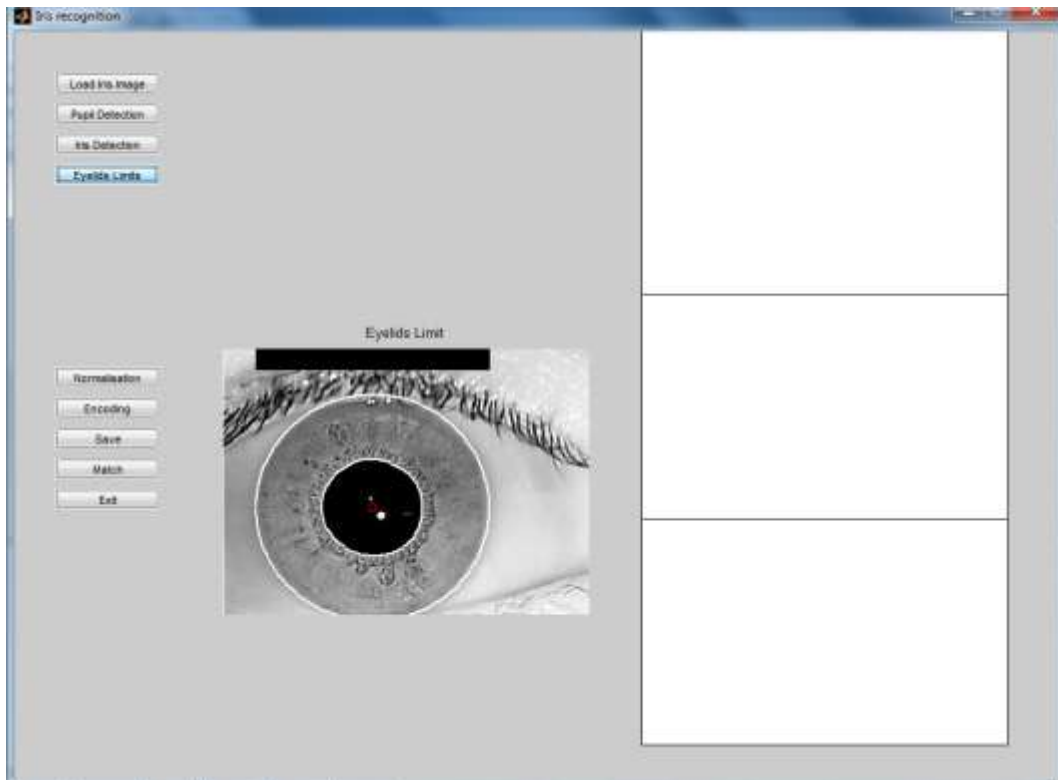

Figure 5.36 : Eyelid detection

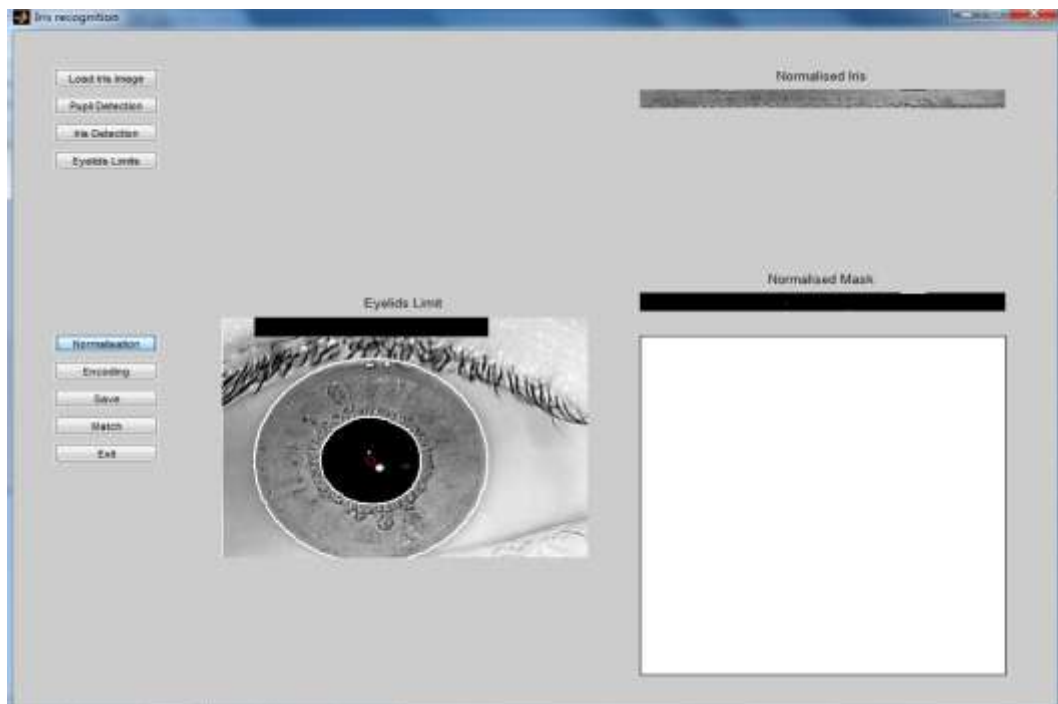

Figure 5.37 : working of normalisation module

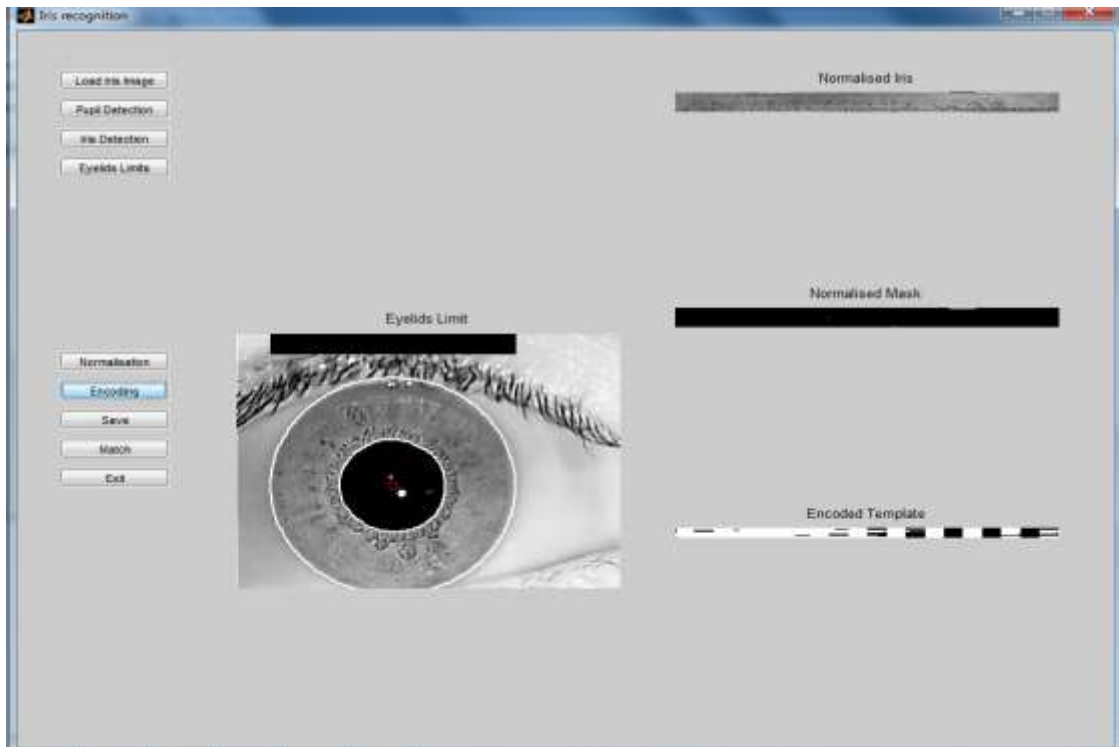

Figure 5.38 : working of template encoding module

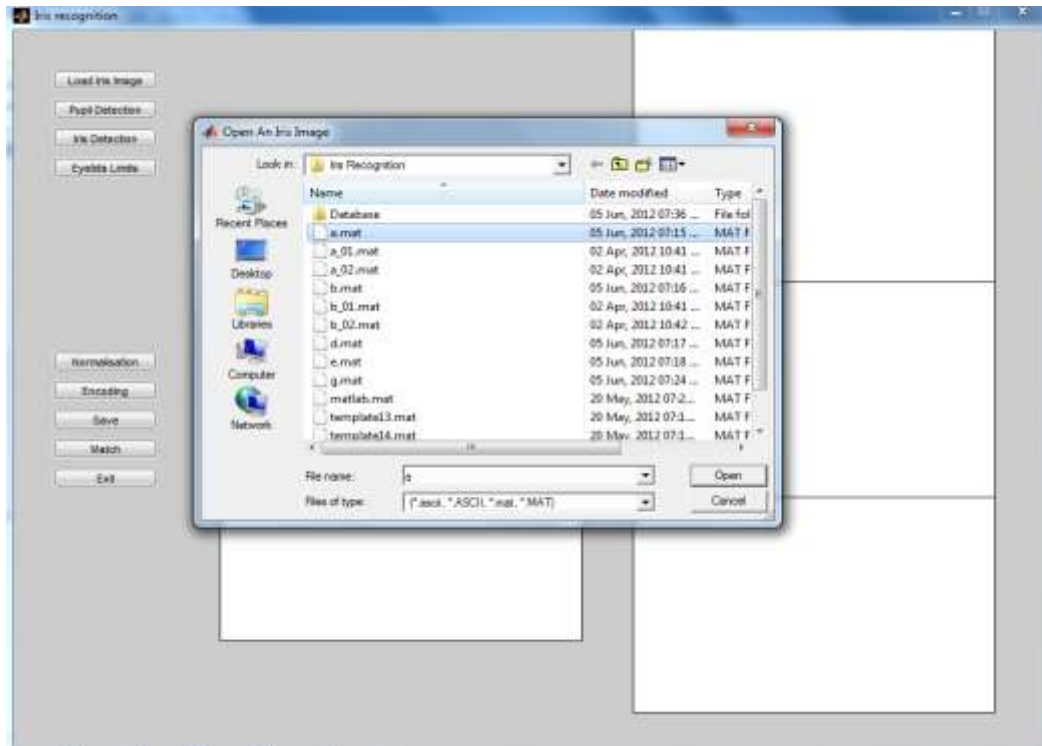

Figure 5.39 : working of matching module (selecting template 'a')

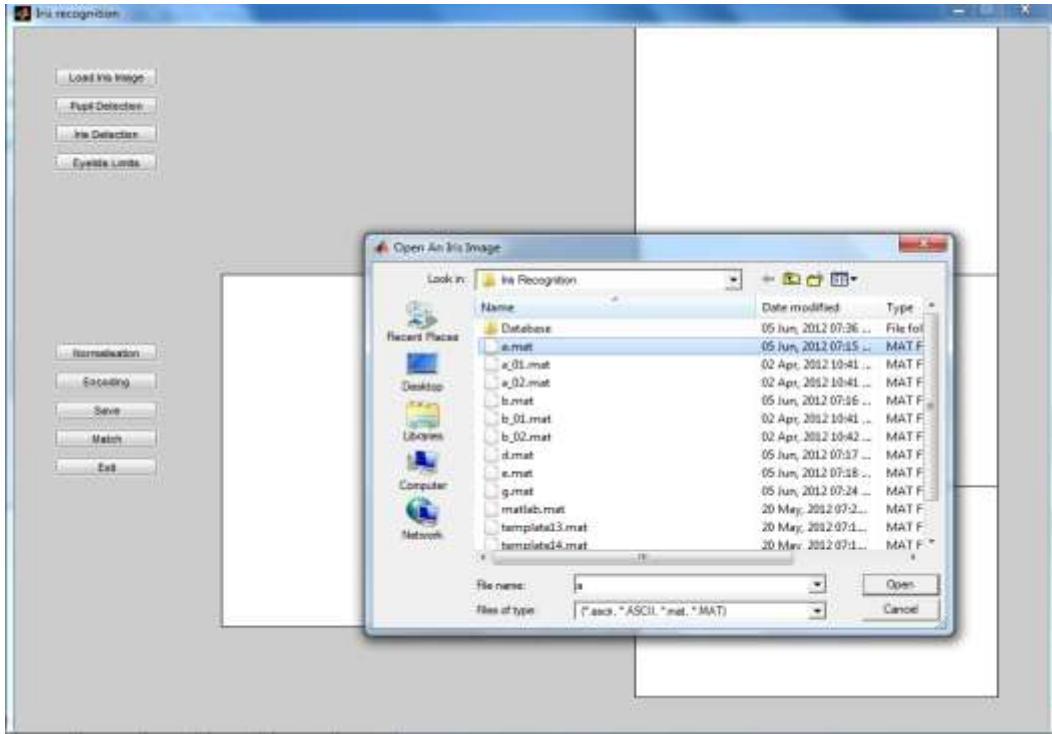

Figure 5.40 : working of matching module (again selecting template 'a')

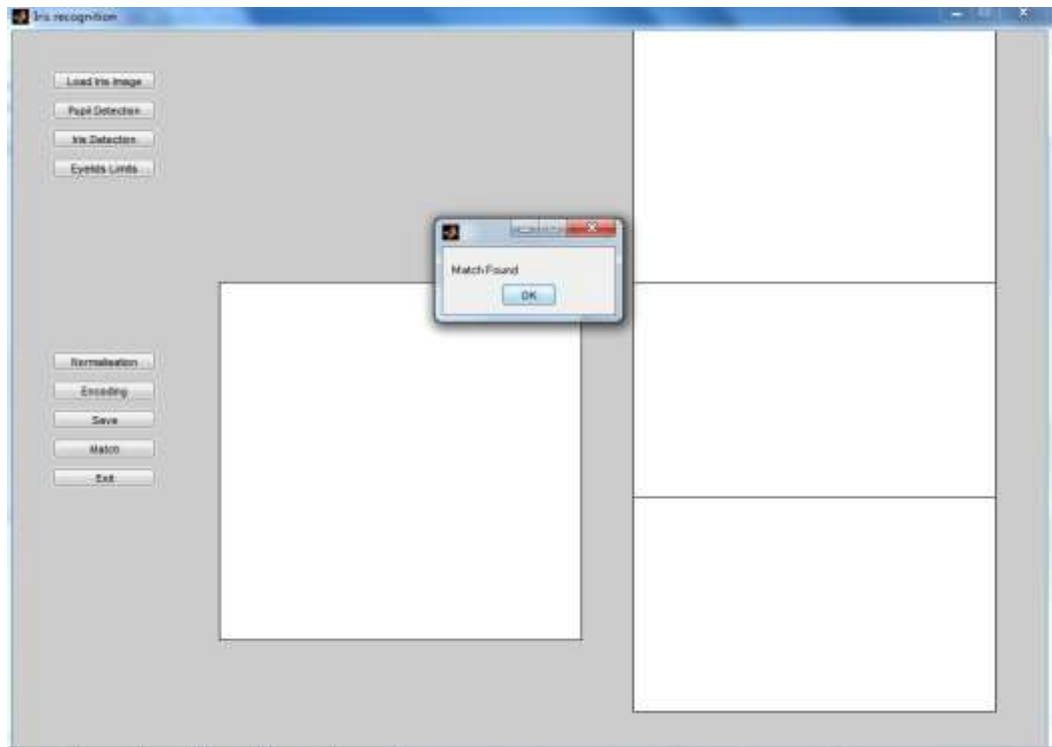

Figure 5.41 : working of matching module (giving 'Match Found' as result)

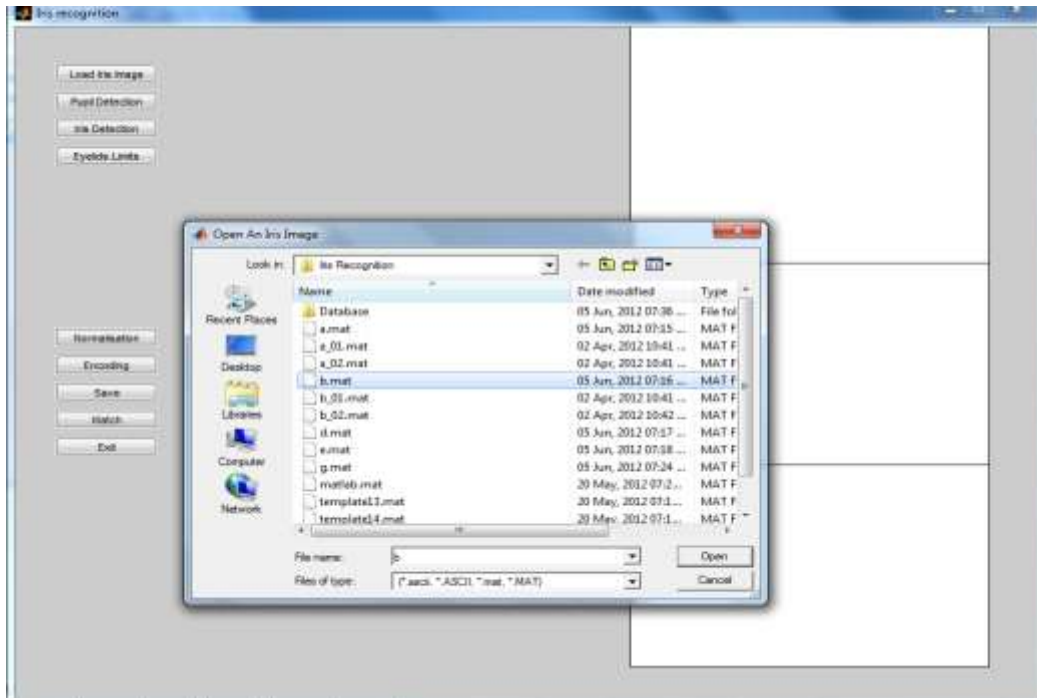

Figure 5.42 : working of matching module (again selecting template 'b')

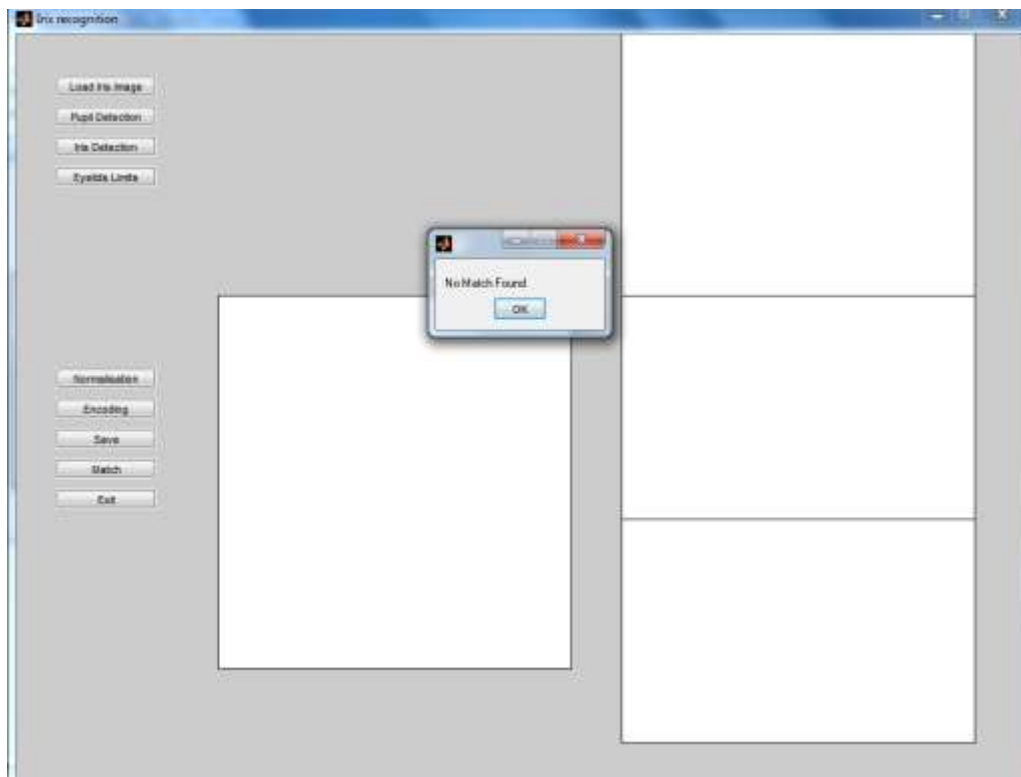

Figure 5.43 : working of matching module (giving ' No Match Found' as result)
 This culminates our experimental result part of present work.

Conclusion and Future Research

The iris recognition technology is comprehensively studied and implemented taking different characteristic feature. Our work on locating the iris region with help of pupil region by taking two assumption that

1. The intensity of brightness of sclera is greater than iris, whose intensity if brightness is in turn greater than pupil.
2. Iris and pupil are concentric.

worked in fair manner in terms of segmentation, normalisation, encoding as well as template matching module. As discussed by Gibbs [41] we again stress that one must understand the nature of the environment before one can understand the nature of visual processing. However, his comments have gone largely unheeded in the mainstream of vision research. the efficiency of a code will depend on the statistics of the input (i.e., the images). The definition of an efficient, or optimal, code depends on two parameters: the goal of the code and the statistics of the input. Hence every biometric input data will be a deciding factor of what sort of algorithm it requires which is also applicable in our case. As we have seen in chapter 5, depending upon various dimensional features viz. distance of camera from iris, image quality of iris etc., the performance of our work varies in fairly good manner. We need not to extract iris region rather with help of above assumptions we have fairly segmented iris region with help of pupil dimensions.

Future Research

The future prospects of this work includes calculating those images in which pupil pixels as well as eyelash pixels overlap.

Next future prospect can be rigorous statistical treatment in intensity algorithm part in which a set of pixels can be taken of each pupil, iris and sclera to find standard deviation. The maximum variation thus obtained could be marked as boundary of each region.

Further iris technology could be comprehensively used with many other biometric features, as in “Aadhar Card” of Government of India for efficient public delivery system.

References

- [1] <http://biometrics.cse.msu.edu/info.html>
- [2] Jain, A., Hong, L., & Pankanti, S. “*Biometric Identification Communications*” of the ACM, 43(2), 2000.
- [3] Jain, Anil K.; Ross, Arun “*Introduction to Biometrics*”. In Jain, AK; Flynn, P; Ross, A. Handbook of Biometrics. Springer. pp. 1–22. ISBN 978-0-387-71040-2, 2008.
- [4] Jain, A.K.; Bolle, R.; Pankanti, S., eds. “*Biometrics: Personal Identification in Networked Society*”. Kluwer Academic Publications, 1999.
- [5] Sahoo, Soyuj Kumar; Mahadeva Prasanna, SR, Choubisa, Tarun “*Multimodal Biometric Person Authentication : A Review*”. IETE Technical Review 29 (1): 54. retrieved 23 February 2012.
- [6] A. Rattani, “*Adaptive Biometric System based on Template Update Procedures*,” PhD thesis, University of Cagliari, Italy, 2010
- [7] A. Rattani, B. Freni, G. L. Marcialis and F. Roli, “*Template update methods in adaptive biometric systems: a critical review*,” 3rd International Conference on Biometrics, Alghero, Italy, pp. 847-856, 2009
- [8] N. K. Ratha, J. H. Connell, and R. M. Bolle, “*Enhancing security and privacy in biometrics-based authentication systems*,” IBM systems Journal, vol. 40, pp. 614–634, 2001.
- [9] S. Tulyakov, F. Farooq, and V. Govindaraju, “*Symmetric Hash Functions for Fingerprint Minutiae*,” Proc. Int'l Workshop Pattern Recognition for Crime Prevention, Security, and Surveillance, pp. 30–38, 2005
- [10] A. B. J. Teoh, A. Goh, and D. C. L. Ngo, “*Random Multispace Quantization as an Analytic Mechanism for BioHashing of Biometric and Random Identity Inputs*,” Pattern Analysis and Machine Intelligence, IEEE Transactions on, vol. 28, pp. 1892–1901, 2006.
- [11] M. Savvides, B. V. K. V. Kumar, and P. K. Khosla, “*Corefaces – Robust Shift-Invariant PCA based Correlation Filter for Illumination Tolerant Face Recognition*,” presented at IEEE Computer Society Conference on Computer Vision and Pattern Recognition (CVPR'04), 2004.

- [12] M. A. Dabbah, W. L. Woo, and S. S. Dlay, "Secure Authentication for Face Recognition," presented at Computational Intelligence in Image and Signal Processing, 2007. CIISP 2007.IEEE Symposium on, 2007.
- [13] S. Sanderson, J. Erbetta "Authentication for secure environments based on iris scanning technology" IEE Colloquium on Visual Biometrics, 2000.
- [14] E. Wolff "Anatomy of the Eye and Orbit", 7th edition. H. K. Lewis & Co. LTD, 1976.
- [15] J. Daugman "High confidence visual recognition of persons by a test of statistical independence", IEEE Transactions on Pattern Analysis and Machine Intelligence, Vol. 15, No. 11, 1993.
- [16] J. Daugman "How iris recognition works", Proceedings of 2002 International Conference on Image Processing, Vol. 1, 2002.
- [17] http://uidai.gov.in/UID_PDF/Working_Papers/UID_and_iris_paper_final.pdf
- [18] http://www.uidai.gov.in/documents/Biometrics_Standards_Committee%20report.pdf
- [19] Page 4, Executive Summary, Biometrics Committee report, http://www.uidai.gov.in/documents/Biometrics_Standards_Committee%20report.pdf
- [20] Page 5, Executive Summary, Biometrics Committee report, http://www.uidai.gov.in/documents/Biometrics_Standards_Committee%20report.pdf
- [21] Page 30, Annexure II, Biometrics Committee report, http://www.uidai.gov.in/documents/Biometrics_Standards_Committee%20report.pdf
- [22] R. Wildes "Iris recognition: an emerging biometric technology" Proceedings of the IEEE, Vol. 85, No. 9, 1997.
- [23] R. Wildes, J. Asmuth, G. Green, S. Hsu, R. Kolczynski, J. Matey, S. McBride "A system for automated iris recognition" Proceedings IEEE Workshop on Applications of Computer Vision, Sarasota, FL, pp. 121-128, 1994.
- [24] W. Boles, B. Boashash "A human identification technique using images of the iris and wavelet transform" IEEE Transactions on Signal Processing, Vol. 46, No. 4, 1998.

- [25] S. Lim, K. Lee, O. Byeon, T. Kim “*Efficient iris recognition through improvement of feature vector and classifier*”, ETRI Journal, Vol. 23, No. 2, Korea, 2001.
- [26] S. Noh, K.Pae, C. Lee, J. Kim “*Multiresolution independent component analysis for iris identification*”, The 2002 International Technical Conference on Circuits/Systems, Computers and Communications, Phuket, Thailand, 2002.
- [27] W. Kong, D. Zhang. “*Accurate iris segmentation based on novel reflection and eyelash detection model*”, Proceedings of 2001 International Symposium on Intelligent Multimedia, Video and Speech Processing, Hong Kong, 2001.
- [28] C. Tisse, L. Martin, L. Torres, M. Robert. “*Person identification technique using human iris recognition*”, International Conference on Vision Interface, Canada, 2002.
- [29] L. Ma, Y. Wang, T. Tan. “*Iris recognition using circular symmetric filters*”, National Laboratory of Pattern Recognition, Institute of Automation, Chinese Academy of Sciences, 2002.
- [30] N. Ritter “*Location of the pupil-iris border in slit-lamp images of the cornea*”, Proceedings of the International Conference on Image Analysis and Processing, 1999.
- [31] Y. Zhu, T. Tan, and Y. Wang, “*Biometric personal identification based on iris pattern*,” ICPR2000: the 15th International Conference on Pattern Recognition, Barcelona, Spain, 805-808, (2002).
- [32] L. Mai, T. Tan, Y. Wang, and D. Zhang, “*Personel identification based on iris texture analysis*,” IEEE Trans. On Pattern Analysis and Machine Intelligence 25(12):1519-1533, (2003).
- [33] Y. Du, R. Ives, C-I. Chang, D. Etter, and T. Welch, “*Information divergence-based iris pattern recognition for automatic human identification*,” Proc. SPIE 5404, 2004.
- [34] MahboubbehShamsi and PutehSaad, “*Iris Segmentation And Normalization Approach*, *JurnalTeknologiMaklumat*”, FSKSM, UTM, 2008.
- [35] L. Masek , “*Recognition of Human Iris Patterns for Biometric Identification*”, Master thesis, University of Western Australia, 2003.
- [36] A. Oppenheim, J. Lim. “*The importance of phase in signals*”, Proceedings of the IEEE 69, 529-541, 1981.

- [37] T. Lee. "*Image representation using 2D gabor wavelets*", IEEE Transactions of Pattern Analysis and Machine Intelligence, Vol. 18, No. 10, 1996.
- [38] D. Field. "*Relations between the statistics of natural images and the response properties of cortical cells*", Journal of the Optical Society of America, 1987.
- [39] P. Burt, E. Adelson , "*The laplacian pyramid as a compact image code*", IEE Transactions on Communications, Vol. COM-31, No. 4, 1983.
- [40] Y. Zhu, T. Tan, Y. Wang , "*Biometric personal identification based on iris patterns*", Proceedings of the 15th International Conference on Pattern Recognition, Spain, Vol. 2, 2000.
- [41] J. J. Gibson, "*The Perception of the Visual World*", Houghton Mifflin, Boston, 1966.
- [42] http://www4.comp.polyu.edu.hk/~csajaykr/IITD/Database_Iris.htm