

Optimizing Agro-Waste in Mulching: An Alternative to Power Generation

*Thesis submitted in partial fulfillment of the requirement for
the award of degree of*

**Master of Engineering
in
Electronic Instrumentation and Control**



Submitted by
Jagmohan Singh
(801051007)

Under the supervision of
Dr. Mandeep Singh
Associate Professor

July 2012

**Department of Electrical and Instrumentation
Engineering
Thapar University**

(Established under the section 3 of UGC act, 1956)
Patiala, 147004

CERTIFICATE

I hereby certify that the work being presented in this thesis entitled “**Optimizing Agro-Waste in Mulching: An Alternative to Power Generation**” in partial fulfillment of award of degree of **Master of Engineering in Electronic Instrumentation and Control**, submitted in Electrical and Instrumentation Engineering department, Thapar University, Patiala, is an authentic record of my own work carried under the supervision of **Dr. Mandeep Singh**, Associate Professor, Department of Electrical and Instrumentation Engineering, Thapar University, Patiala, Punjab.

Date: 12, July 2012

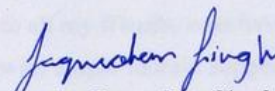

Jagmohan Singh
801051007

I certify that the above statement made by the student is correct to the best of my knowledge and belief.

Date: 12/7/12

Dr. Mandeep Singh
Associate Professor
Department of Electrical and
Instrumentation Engineering
Thapar University, Patiala
Punjab

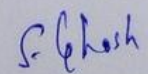
Countersigned By



Dr. Smarajit Ghosh
Head of Department
Department of Electrical and
Instrumentation Engineering
Thapar University, Patiala
Punjab

Dr. S. K. Mohapatra
Dean (Academic Affairs)
Thapar University, Patiala
Punjab

Optimizing Agro-waste in Mulching: An Alternative to Power Generation

ACKNOWLEDGEMENT

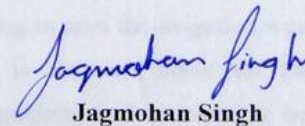
I would like to express my deep gratitude to **Dr. Mandeep Singh**, Associate Professor, Department of Electrical and Instrumentation Engineering, Thapar University, Patiala for his patient guidance and support throughout this thesis work. I am truly fortunate to have the opportunity to work with him. I am also thankful to our Head of the Department, **Dr. Smarajit Ghosh** as well as, the entire faculty and staff members of Electrical and Instrumentation Department who devoted their valuable time and helped me in all possible ways towards successful completion of this work. I am greatly indebted to all my friends, who have graciously applied themselves to the task of helping me with ample morale support and valuable suggestions. Finally, I would like to thank my parents for their years of unyielding love and encouragement. They have always wanted the best for me and I admire their determination and sacrifice.



Jagmohan Singh

(801051007)

ABSTRACT

Agricultural waste generated by several agricultural activities has many alternative uses. Unfortunately much of it is burnt in the open fields leading to environmental pollution. For the management of agro-waste one way adopted is to produce electricity using this agro-waste as fuel. But Agro-waste power generation faces major risks like fuel availability and unstable prices, problems of ash melting, slagging, clinkerisation at the base of boilers, super heater choking, agglomeration and drop in boiler temperature due to moisture in the bales. All these problems result in frequent shut downs of the plants and they do not operate continuously. Transportation of agro-waste from fields to power generation plants add to gas emission and labour cost. The other alternative for efficient utilisation of agro-waste like paddy straw and rice husk is mulching.

Mulching technically means covering of soil. Mulch provide the conditions that are favourable for the growth of plant and crop production. It is observed that mulching saves the irrigation water by increasing moisture retention of soil. This study was conducted to determine the optimal amount of mulching to save the irrigation water, because excessive use of crop residue as mulch is also not beneficial from economical point of view. The amount of optimal mulching is determined to be 8 tonnes per hectare. Further, mulching saves 45% of the commercial cost by way of reduced irrigation.

CONTENTS

CONTENTS	PAGE NO.
FRONT PAGE	I
CERTIFICATE	II
ACKNOWLEDGEMENT	III
ABSTRACT	IV
CONTENTS	V-VII
LIST OF FIGURES	VIII
LIST OF TABLES	IX-X
LIST OF SYMBOLS AND ABBREVIATIONS	XI
Chapter 1: Introduction	1-10
1.1 Indian Electricity Scenario	1
1.2 Power Generation in Punjab	4
1.3 Renewable Energy Sources in India	5
1.3.1 Grid Connected Power	6
1.3.2 Off-Grid Power	9
Chapter 2: Agro-Waste Power Generation	11-24
2.1 Agro-Waste	11
2.2 Open Filed Burning of Agro-Waste	12
2.2.1 Impacts of Open Filed Residue Burning	14

2.3 Agro-Waste Power Potential	15
2.4 Power Generation in Punjab Using Agro-Waste	19
2.5 A Case Study	20
2.6 Pollution by Agro Waste Power Plants	22
2.7 Alternative	23
Chapter 3: Mulching	25-32
3.1 Mulching	25
3.2 Types Of Mulching	25
3.2.1 Organic Mulching	25
3.2.2 Inorganic Mulching	27
3.3 Benefits of Mulching	29
3.4 Mulching as Alternative	31
Chapter 4: Literature Review	33-37
Chapter 5: Problem Definition	38
Chapter 6: Methodology	39-49
6.1 Calculations to Done	39
6.2 Methodology of The Study	39
6.2.1 Site Selection	39
6.2.2 Site Preparation	40
6.2.3 Mulch Preparation	40
6.2.4 Mulching Paddy Straw	41

6.3 Soil Composition	42
6.3.1 Soil Saturation	42
6.3.2 Saturation Percentage	43
6.4 Percent Moisture Calculations without Meter	43
6.4.1 Gravimetric method	
6.5 Methods of soil moisture measurement with meters	44
6.5.1 Neutron scatter	44
6.5.2 Di-electric Constant Methods	45
6.5.3 Tensiometer	46
6.5.4 Electrical Resistance Blocks	47
6.6 Measuring Method Adopted	48
6.7 Procedure Of Taking Readings	49
Chapter 7: Results And Discussions	50-63
7.1 Moisture Percentage Readings	50
7.2 Measuring Water Saving	54
7.3 Extending the Range for Optimisation	56
7.4 Water Pumping Cost Per Litre	61
7.5 Saving of Electricity	62
7.6 Recommendations	63
Chapter 8: Conclusion	64
Chapter 9: Future Scope	65

REFERENCES	66-69
List of Publications	70

LIST OF FIGURES

FIGURE	FIGURE NAME	PAGE NO.
Figure 1.1	Indian Electricity Scenario (As on 30-04-2012)	1
Figure 1.2	India Electricity Consumption Sector Wise (2010-11)	3
Figure 1.3	Electricity Scenario of United States And France	3
Figure 1.4	Biomass Conversion Paths	7
Figure 2.1	Open Field Burning of Paddy Residue	13
Figure 2.2	Conversion Routes for Agricultural Biomass Waste	15
Figure 2.3	Availability of Agro-Waste	21
Figure 2.4	Causes and Effect Diagram	22
Figure 3.1	Straw Mulching	26
Figure 3.2	Plastic Mulching	28
Figure 6.1	Site selected	40
Figure 6.2	Paddy Straw	41
Figure 6.3	Mulched plots	41
Figure 6.4	Composition of the soil	42
Figure 6.5	Soil moisture characteristics	42
Figure 6.6	Neutron Method of Soil Moisture Measurement	45
Figure 6.7	Time Domain Reflectometry (TRD) Probe	46
Figure 6.8	Tensiometer installation	47
Figure 6.9	Electrical Resistance Blocks	47
Figure 6.10	Soil Moisture Meter And Its Probe	48
Figure 6.11	Procedure of Taking Readings	49
Figure 7.1	Readings from 06/03/12 to 11/03/2012	51
Figure 7.2	Readings from 12/03/12 to 04/04/2012	53
Figure 7.3	Soil Moisture Sensitivity	55
Figure 7.4	Readings from 06/04/12 to 09/04/2012	57
Figure 7.5	Readings from 13/04/12 to 29/04/2012	59
Figure 7.6	Tube Well Tank Measurements	61

LIST OF TABLES

TABLE	TABLE NAME	PAGE NO.
Table 1.1	Fuel consumed in India to generate power	2
Table 1.2	All India power supply position energy-wise & peak-wise (from 2007 -2011)	2
Table 1.3	Installed capacity of Punjab as on 31.12.2010 (figure in mw)	4
Table 1.4	Punjab's power supply position at the end of 2011-12 (demand as per 17 th electricity power survey)	4
Table 1.5	Non-conventional energy projects commissioned & under execution in Punjab	5
Table 1.6	State-wise wind power potential in India	6
Table 1.7	State-wise/year-wise list of commissioned biomass power/cogeneration projects (as on 31.03.2011)	8
Table 1.8	Power from renewable in India as on 30.04.2012	10
Table 2.1	Crop and its residue	11
Table 2.2	Calorific value of Agro-wastes	12
Table 2.3	Emission factors of gas pollutions emitted from burning of rice, wheat and corn straws (g kg ⁻¹)	13
Table 2.4	Greenhouse gas emission from burning of rice straw in northwest India (in Tg)	13
Table 2.5	Estimated loss of nutrients caused by burning of crop residues in rice-wheat system	14
Table 2.6	Residue-wise Biomass In India: Based on Survey Data [2002-04]; Season : Agro-Kharif	16
Table 2.7	Residue-wise Biomass in India - Year : Based on Survey Data [2002-04] ; Season : Agro-Rabi	17
Table 2.8	Jalkheri Power Plant Specifications	20
Table 2.9	Fuel Required Per Unit	21
Table 3.1	Water saving with mulching and tillage method of irrigation	29
Table 6.1	Mulch amount during Study Part 1	41

Table 6.2	Saturation Percentage of different soil types	43
Table 6.3	Meter's Specification	48
Table 7.1	Moisture readings of the plots with various mulching amounts before rain i.e. from 06/03/12 to 11/03/2012	50
Table 7.2	Moisture readings of the plots with various mulching amounts after rain i.e. from 12/03/12 to 04/04/2012	52
Table 7.3	Water added to raise moisture percentage to 95 %	54
Table 7.4	Water saving in each plot with unmulched plot as control	54
Table 7.5	Water saving per Kg straw	55
Table 7.6	Soil Moisture Sensitivity	55
Table 7.7	Mulching amount of plots for extending the range for optimisation	56
Table 7.8	Readings from 06/04/12 to 09/04/2012	57
Table 7.9	Readings from 13/04/12 to 29/04/2012	58
Table 7.10	Water added to raise moisture percentage to 95 %	60
Table 7.11	Water saving in each plot with unmulched plot as control	60
Table 7.12	Water saving per Kg straw	60
Table 8.1	Farmers Options	64

LIST OF SYMBOLS AND ABBREVIATIONS

CEA	Central Electricity Authority
InWEA	Indian Wind Energy Association
SERC	State Electricity Regulatory Commissions
MNRE	Ministry of New and Renewable Energy
IREDA	Indian Renewable Energy Development Agency Limited
PEDA	Punjab Energy Development Agency
kW	Kilowatt
kWhr	Kilowatt hour
MWhr	Megawatt Hour
kCal	Kilocalorie
CO ₂	Carbon dioxide
CO	Carbon monoxide
NO ₂	Nitrogen Dioxide
NO	Nitrogen Oxide
N ₂ O	Nitrous Oxide
CH ₄	Methane
N	Sodium
K	Potassium
S	Sulphur
T	Tonne
ha	hectare
TDR	Time domain reflectometry
FDR	Frequency domain reflectometry

Chapter 1

Introduction

1.1 Indian Electricity Scenario

Power sector in India has taken long steps during last six decades in power generation. The installed generation capacity in India was only 1362 MW in 1947. The power generation in country has since grown to 2,02,979 MW at end of April 2012. 90.6% of the total villages are electrified now in India. Today, India ranks fifth in the world in total energy consumption. India is highly dependent upon fossil fuels for power generation, 66% of the total power generation is from thermal power plants, 20% is from Hydro power plants and only 12% of total power is contributed by renewable sources. The overall generation in India has increased to 811.144 Billion Unit from 771.551 Billion Unit (BU) during year 2010-11. The Nuclear generation performance is improved by 40.94% during this period. The Overall growth is 5.56% during 2010-11 [1]. The per capita electricity consumption in India is 813.3 kWhr (2011) and this figure is steadily increasing. The world average per capita electricity consumption is 2782 kWhr (2008). Indian electricity scenario is shown in figure 1.1.

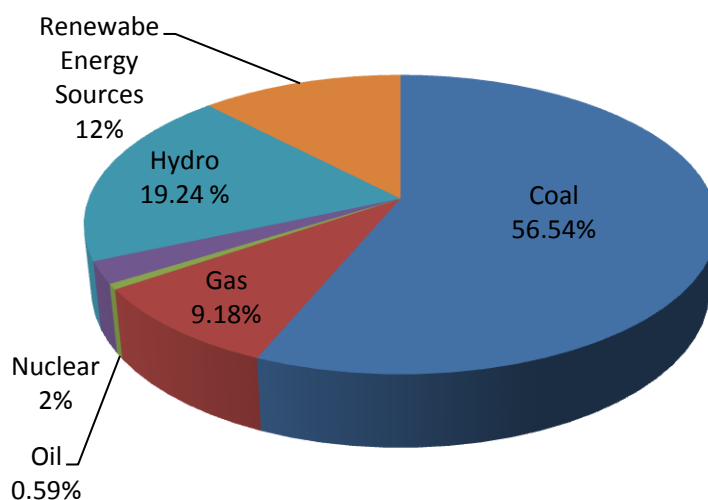

Figure 1.1: Indian Electricity Scenario (As on 30-04-2012)

Table 1.1: Fuel Consumed in India to Generate Power

Fuel	Megawatts	Percentage
Total Thermal	134635.18	66.32
Coal	114,782.38	56.54
Gas	18,653.05	9.18
Oil	1,199.75	0.59
Hydro (Renewable)	39,060.40	19.24
Nuclear	4,780.00	2.35
Renewable Energy Sources	24,503.45	12.07
Total	2,02,979.03	100.00

Source: Central Electricity Authority (CEA), <http://www.cea.nic.in/>

Renewable power generation includes biomass gasifiers, biomass power, urban and industrial waste power, wind energy etc. India has a potential for developing these renewable sources to bridge the gap between available and required electricity. India suffers from shortfall of electricity. In addressing to this problem, Indian government continues to work toward adding capacity . The power supply position of India from 2007 to 2011 is given in Table 1.2.

Table 1.2: All India Power Supply Position Energy-Wise & Peak-Wise (From 2007 - 2011)

Year	Energy				Peak Demand			
	Requirement (GWh)	Availability (GWh)	Deficit (GWh)	Deficit (%)	Demand (MW)	Availability (MW)	Deficit (MW)	Deficit (%)
2007-08	739343	666007	73336	9.92	108866	90793	18073	16.60
2008-09	777039	691038	86001	11.07	109809	96785	13024	11.86
2009-10	830594	746644	83950	10.11	119166	104009	15157	12.72
2010-11	861591	788355	73236	8.50	122287	110256	12031	9.84

Source: Ministry of power, <http://www.powermin.nic.in/>

The gap between availability and requirement is decreasing year by year, as shown in table. Deficit was 16.60 % in 2007-2008 but it decreased to 9.84 % during 2010-11.

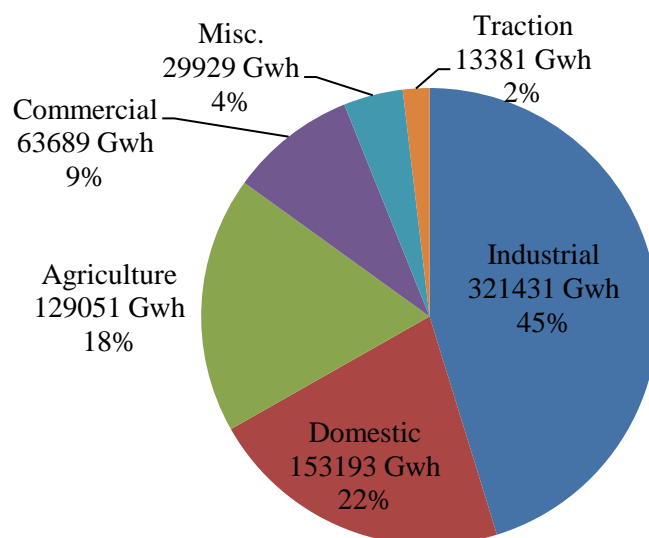

Figure 1.2: India Electricity Consumption Sector Wise (2010-11)

The major consumption of electricity in India, a developing country, is in industrial sector as shown in figure 1.2. As shown in table 1.1, 66% of total generation is from thermal plants, where fossil fuels like coal, oil and gases are used to generate electricity. However, the electricity scenario of developed country is not much dependent on conventional methods of generation. In United states, nuclear plants and natural gas plants play a important role in power generation. In France, 78% of total generation is from nuclear plants and only 4 % of total generation is produced from coal thermal plants as shown in figure 1.3.

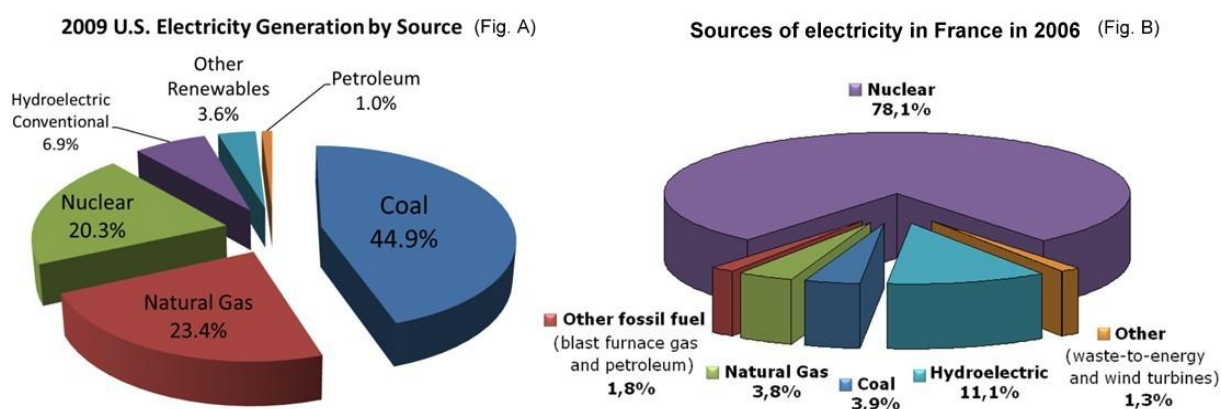

Figure 1.3: Electricity Scenario of United States and France

1.2 Power Generation in Punjab

In Punjab, Thermal and hydel plants are main sources of power generation. The installed capacity of its own thermal and hydro units, excluding share from central sector is 2655 MW and 2230 MW respectively as on 31.12.2010. [2]

Table 1.3: Installed Capacity of Punjab as On 31.12.2010 (Figure In MW)

Sector	Hydro	Thermal				Nuclear	R.E.S. (MNRE)	Total
		Coal	Gas	Diesel	Total			
STATE	2230.23	2630.00	25.00	0.00	2655.00	0.00	222.55	5107.78
PRIVATE	0.00	0.00	0.00	0.00	0.00	0.00	73.08	73.08
CENTRAL	742.66	578.19	263.92	0.00	842.11	208.04	0.00	1792.81
TOTAL	2972.89	3208.19	288.92	0.00	3497.11	208.04	295.63	6973.67

Source: Central Electricity Authority (CEA), <http://www.cea.nic.in/>

According to Central Electricity Authority (CEA) there is 38.8% energy deficit in Punjab during 2011-2012 as shown in table 1.4.

Table 1.4: Punjab's Power Supply Position at the End of 2011-12 (Demand As Per 17th Electricity Power Survey)

Period	Peak Demand (MW)	Peak Met (MW)	Peak deficit/ Surplus (MW)	Peak Deficit/ Surplus (%)	Energy Requirement (MU)	Energy Availability (MU)	Energy Deficit/ Surplus (MU)	Energy Deficit/ Surplus (%)
2011-12	11000	5488	-5512	-50.1	60489	37008	-23481	-38.8

Source: Central Electricity Authority (CEA), <http://www.cea.nic.in/>

Punjab is predominantly rich in agriculture and contributes the major share to the grain basket of India. It has a high level of agricultural productivity due to its sophisticated techniques which compare well with the advanced countries of the world. The agriculture production in the last three years has shown a remarkable upward trend and Punjab once again has surplus production of major crops. It is a matter of pride that though Punjab has only 1.5 percent of the total country's cultivable area, yet it produces 25 percent of country's cotton, 55 percent of wheat and 28 percent of rice. Punjab also possesses the most developed and extensive network of canals in the country.

Punjab has substantial renewable energy potential in the areas of Biomass / Agro waste. The availability of Biomass / Agro waste in the state is sufficient to produce about 1000MW of electricity. Role of Biomass / Agro waste based projects is an attempt to supplement energy generation as short / medium term measures has been well identified and accepted. Agro waste based power generation projects which were earlier considered uneconomical are now considered acceptable and viable in view of the steep increase of cost of several other forms of energy and the rapid depletion of their sources and latest technologies developed in the design of such projects.

Table 1.5: Non-Conventional Energy Projects Commissioned & Under Execution in Punjab

S. No.	Type	Capacity In Use		Capacity Under Execution	
		Total Units	Capacity (MW)	Total Units	Capacity (MW)
1	Micro/Mini Hydel	16	19.2	41	36
2	Biomass	2	16	1	6
3	Solar plants	1	0.2	3	0.125
4	Co-generation	2	12.3	3	23
5	Waste to Energy	1	1	1	6
6	Solar PV pumps	1700	-	700	-
7	Solar street lights	2666	-	-	-
8	Home lights	3570	-	-	-
9	Solar lanterns	14995	-	-	-

Source: K.S.Sidhu (2010) [3]

1.3 Renewable Energy Sources In India

The total potential of renewable sources in India is 82,000 MW, but the total capacity installed is only 6422 MW. Ministry of India has estimated the biomass availability is about 120-150 metric tonne per annum including agro waste and forest residue which has an potential of about 1800 MW [4]. Renewable energy power plants can either be grid connected or off grid power plant.

1.3.1 Grid Connected Power

Grid-connected renewable power projects based on wind power, biomass, small hydro and solar are mainly private investment driven, with favourable tariff policy regimes established by State Electricity Regulatory Commissions (SERC).

Wind Power: India has the fifth largest installed wind power capacity in the world [5]. The Indian wind energy sector has an installed capacity of 17389 MW (as on April 30, 2012). Indian Wind Energy Association (InWEA) has estimated that with the current level of technology, the ‘on-shore’ potential for utilization of wind energy for electricity generation is of the order of 48,500 MW [6]. State wise wind power potential is shown in table 1.6.

Table 1.6: State-Wise Wind Power Potential in India [4]

S. No.	States/UTs	Installable Potential (in MW)
1.	Andhra Pradesh	5394
2.	Gujarat	10609
3.	Karnataka	8591
4.	Kerala	790
5.	Madhya Pradesh	920
6.	Maharashtra	5439
7.	Rajasthan	5005
8.	Tamil Nadu	5374
9.	Orissa	910
10.	West Bengal	22
11.	Andaman & Nicobar	2
12.	Arunachal Pradesh	201
13.	Assam	53
14.	Chhattisgarh	23
15.	Himachal Pradesh	20
16.	Jammu Kashmir	5311
17.	Lakshdweep	16
18.	Manipur	7
19.	Meghalaya	44
20.	Nagaland	3
21.	Sikkim	98
22.	Uttarakhand	161
23.	Uttar Pradesh	137
	TOTAL	49130

Bio power/Agriculture waste and residue power: In this system agro residue & agricultural wastes ,biomass, bagasse and forestry are used as fuel to produce electricity, with the aim to generate competitively priced bio power and/or heat.

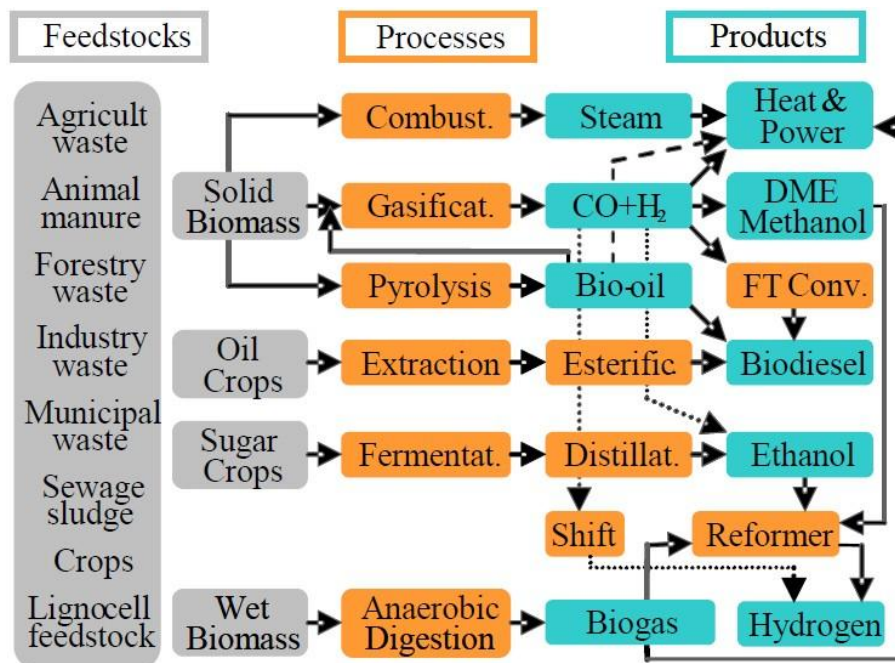

Figure 1.4: Biomass Conversion Paths

Source: "Biomass for power generation and CHP", International Energy Agency 2007

The current availability of biomass in India is estimated at about 500 million metric tonnes per year. The Ministry of New and Renewable Energy has estimated that surplus biomass availability is about 120-150 million metric tonnes per annum covering agricultural and forestry residues corresponding to a potential of about **18,000 MW**. This apart, about **5000 MW** additional power could be generated through bagasse based cogeneration in the country's 550 Sugar mills [4].

Solar: About 5,000 trillion kWhr per year energy is incident over India land area with most parts receiving 4-7 kWhr per sq. m per day. Solar also provides the ability to generate power on a distributed basis and enables rapid capacity addition with short lead times. Theoretically, a small fraction of the total incident solar energy if captured effectively, can meet the entire country's power requirements[4].

Table 1.7: State-Wise/Year-Wise List of Commissioned Biomass Power/Cogeneration Projects (As On 31.03.2011)

S.No.	State	Upto 31.03.2003	2003- 04	2004- 05	2005- 06	2006- 07	2007- 08	2008- 09	2009- 10	2010- 11	Total
1	Andhra Pradesh	160.05	37.70	69.50	12.00	22.00	33.00	9.00	20.00	..	363.25
2	Bihar		--	--	--	--	--	--	--	9.50	9.50
3	Chattisgarh	11.00	--	--	16.50	85.80	33.00	9.80	43.80	32.00	231.90
4	Gujarat	0.50	--	--	--	--	--	--	--	--	0.50
5	Haryana	4.00	--	2.00	--	--	--	--	1.8	28.00	35.80
6	Karnataka	109.38	26.00	16.60	72.50	29.80	8.00	31.90	42.00	29.00	365.18
7	Madhya Pradesh		1.00	--	--	--	--	--	--	--	1.00
8	Maharashtra	24.50	--	11.50	--	40.00	38.00	71.50	33	184.50	403.00
9	Punjab	22.00	--	--	6.00	--	--	--	34.50	12.00	74.50
10	Rajasthan		7.80	--	7.50	8.00	--	8.00	--	42.00	73.30
11	Tamil Nadu	106.00	44.50	22.50	--	42.50	75.00	43.20	62.00	92.50	488.20
12	Uttarakhand	--	--	--	--	--	--	--	--	10.00	10.00
13	Uttar Pradesh	46.50	12.50	14.00	48.50	--	79.00	172.00	194.50	25.50	592.50
14	West Bengal		--	--	--	--	--	--	16.00	--	16.00
	Total	483.93	129.50	136.10	163.00	228.10	266.00	345.40	447.60	465.00	2664.63

Source: Ministry of New and Renewable Energy(MNRE), India, <http://www.mnre.gov.in>

Biomass Gasifier: In biomass gasifiers solid agro-waste is converted into gaseous fuel. The producer gas obtained by the gasification can be used for mechanical or electrical power generation or for thermal application. Biomass Gasifier power plants produce electricity using locally available biomass resources such as rice husk, small wood chips, cotton stalks and other agro-residues are available to meet the demand of electricity.

Biogas: Agro-waste can be decomposed to make manure or can be used in bio gas plants which will produce gas for household use and its by-product manure can be used in field. Biogas plants convert organic wastes into clean renewable biogas and organic fertilizer source. Biogas production is a clean low carbon technology. During 2011, some 45000 small scale biogas plants were installed. India has installed 4.44 million small scale biogas plants.

1.3.2 Off-Grid Power

Off-grid or decentralized renewable power projects are being established in the country to meet the energy requirements of isolated communities and areas which are not likely to be electrified in near future [4]. Some of the renewable energy technologies that are used in villages and rural areas as decentralized systems are:

- Family-size biogas plants.
- Solar street lighting systems.
- Solar lanterns and solar home lighting systems.
- Solar water heating systems
- Solar cookers.
- Standalone solar/ biomass based power generators.
- Wind pumps.
- Micro-Hydel plants.

The installed capacity grid-connect and off-grid renewable power is 2500 MW and 725 MW respectively as on 30.04.2012. The renewable power scenario in India is as shown in table 1.8.

Table 1.8: Power From Renewable in India as on 30.04.2012

Renewable Energy Programme/ Systems	Target for 2012-13	Total achievement during 2012-13	Cumulative achievement up to 30.04.2012
A. Grid-Interactive Power (Capacities In MW)			
Wind Power	2500	36.65	17389.31
Small Hydro Power	350	5.75	3401.06
Biomass Power	455	16.00	1166.10
Bagasse Cogeneration		7.50	1992.73
Waste to Power	20	-	89.68
Solar Power (SPV)	800	37.72	979.00
Total	4125.00	103.62	25017.88
B. Off-grid/ Captive Power (Capacities in MW_{eq})			
Waste to Energy	20.00	1.20	102.95
Biomass(non-bagasse) Cogeneration	60.00	2.50	385.00
Biomass Gasifiers Rural- Industrial	1.50	-	16.12
	10.00	-	134.09
Aero-Generators/Hybrid systems	0.50	-	1.64
SPV Systems (>1kW)	30.00	-	85.21
Water mills/micro hydel	2.00(500 Nos.)	-	1877 Nos.
Total	126.00	3.70	725.01

Source: Ministry of New and Renewable Energy (MNRE), India <http://www.mnre.gov.in>

Chapter 2

Agro-Waste Based Power Generation

2.1 Agro-Waste

Waste is unavoidable by-product of any activity. Agricultural waste is waste specifically generated by agricultural activities. There are different sources of agro-waste:

Crop waste: Crop residue like paddy straw, rice husk, cotton stalk, sugarcane bagasse, maize stalk, hulls, kernels, peanut shells, groundnut shells, sorghum, soybean stalks, saw dust, sunflower stalks and straws of various pulses and cereals. The main crops and its residues are given in table 2.1. The crop residues are the main source of agro-waste

Table 2.1: Crop and its residue

CROP	WASTE
Coconut	Fronds, husk, shell
Coffee	Hull, husk, ground
Corn	Cob, stover, stalks, leaves
Cotton	Stalks
Peanuts	Shells
Rice	Hull/husk, straw, stalks
Sugarcane	Bagasse
Agricultural Crops	Mixed agricultural crops, not limited to crop waste
Mixed type	Agricultural crops and waste including non-organic wastes

Plant residue: Residue after pruning plants, fruits and vegetables wastes, tree and plant leaves

Animal waste: Cow dung and animal carcasses

The main source of agro-waste is crop residue after harvesting of crops. Paddy straw management is big problem for rice farmers. This crop residue cannot even use as

ruminant fodder because of high silicon content and low cellulose and other sugar contents. But the residue like paddy straw, rice husk, cotton stalks, sugar bagasse etc have high caloric value. Calorific values of different agro-wastes are given in table 2.2.

Table 2.2: Calorific value of Agro-wastes

Type of Material	Ash (%)	Heat of Combustion (kCal)
Peat	29.0	3180
Charcoal	4.5	7213
Paddy Straw	15.50	3469
Bagasse	1.80	4380
Wheat Straw	8.00	4100
Coir Pitch	9.10	4146
Sugarcane	10.00	3996
Jute Waste	3.00	4428
Palm Husk	4.90	3900
Tea Waste	3.80	4237
Barks Wood	4.40	1270
Wood Chips	1.20	4785
Mustard Stalk	3.40	4200
Mustard Shell	3.70	4300
Bamboo Dust	8.00	4160
Forestry Waste	7.00	3000
Sunflower Stalk	4.30	4300
Soya bean Husk	4.10	4170
Groundnut shells	2.4	4626
Briquettes of chips	3.0	4800
Saw Dust Briquettes	8.20	3898
Cotton Stalks / Chips	3.00	4252

2.2 Open Filed Burning of Agro-Waste

Rice –wheat is the major cropping system of Punjab. It occupying more than 2.65 Mha cultivation of high yielding varieties of the rice and wheat. Total production of paddy straw alone constitutes more than 22 Million tons in the state. More than 75% of paddy residue is collected by the farmers using straw combine after combine harvesting. Presently, total paddy straw utilization in Punjab for different purposes constitutes less than 2% of that produced annually [7]. The field burning of paddy straw is a major contributor to reduce air quality and human respiratory ailments in intensive rice

production areas. Substantial loss of plant nutrients and organic carbon also occurs during burning of crop residues which has important implications for soil health [8, 9, 10]. Despite the ban imposed by the district magistrates of various districts, burning of residues has been doing great damage to the environment.



Figure 2.1: Open Field Burning of Paddy Residue

In a laboratory study of agro-waste open field combustion, emission factors of CO₂, CO, NO, NO₂ and NO_x were measured to be 791.3, 64.2, 1.02, 0.79 and 1.81 gram/kilogram respectively for paddy straw as shown in table 2.3 [11].

Table 2.3: Emission factors of gas pollutions emitted from burning of rice, wheat and corn straws (g kg⁻¹) [11]

Chemical species	Rice straw	Wheat straw
CO	64.2 ± 4.9	141.2 ± 14.8
CO ₂	791.3 ± 12.5	1557.9 ± 85.8
NO ₂	0.79 ± 0.05	0.32 ± 0.06
NO	1.02 ± 0.03	0.79 ± 0.13
NO _x	1.81 ± 0.09	1.12 ± 0.19

Table 2.4: Greenhouse gas emission from burning of rice straw in northwest India (in Tg)

State	CO ₂	CO	CH ₄	N ₂ O
Punjab	13.60	0.869	0.047	0.175
Haryana	1.56	0.099	0.005	0.013
Utter Pradesh	11.10	0.706	0.038	0.090
TOTAL	26.26	1.674	0.090	0.278

2.2.1 Impacts of Open Filed Residue Burning

On Human Health: Major part of population in India live in the rice growing areas and exposed to air pollution due to burning of paddy straw after rice crop harvesting. Field burning smoke contains fine particulates matters, which can be inhaled deep into lungs and can cause serious respiratory problems. these are also the major cause of cancer, tuberculosis, asthma, decreased lung functioning, irritation in eyes, congestion in the chest etc.

On animal health: Open field burning of agro-residue can result in death of animals. smoke raises the level of CO₂ and CO in the blood of animals, which results in conversion of normal haemoglobin (Hb) to deadly Hb. Fine particulates matters in smoke also cause temporary blindness, corneal irritation, bronchiolitis leading to asthma and decrease in milk yield [13].

On Soil Properties: Burning of agro waste residue lead to considerable nutrient loss. Large amount of nitrogen, sulphur and potassium are lost because of burning of crop residue in the fields. bacterial and fungal population are also de creased upon burning. The estimated loss of nutrients determined by Sharma et al. 1998 is as shown in table 2.5 [14]

Table 2.5: Estimated loss of nutrients caused by burning of crop residues in rice-wheat system

Straw	Nutrient loss ht ⁻¹			Estimated loss					
				Kg ha ⁻¹			%		
	N	K	S	N	K	S	N	K	S
Rice	48.0	104.8	8.0	42.8	20.8	2.0	89.2	19.0	25.0
Wheat	40.0	92.0	9.6	35.4	16.0	2.4	88.5	17.4	25.0

2.3 Agro-Waste Power Potential

Agricultural waste generated by several agricultural activities has many alternative uses. Unfortunately much of it is burnt in the open fields leading to environmental pollution. Agro-waste is utilized by following various conversion routes to produce energy as shown in figure 2.2. One way to utilise this is to generate electricity in agro-waste based thermal plants.

Biomass based power generation contributes 14% of the total energy produced worldwide and 38% of this energy is consumed in the rural and traditional sectors of developing countries [15]. According to an estimate by Indian Renewable Energy Development Agency Limited (IREDA), there is production of 460 million tonnes of agricultural waste every year. If this waste is used for power generation, it can save 260 million tonnes of coal that results in saving of about Rs. 250 billion every year. Further as per the estimate, India has potential to generate more than 19000MW power through agro-waste alone as shown in table 2.6 and 2.7 [15].

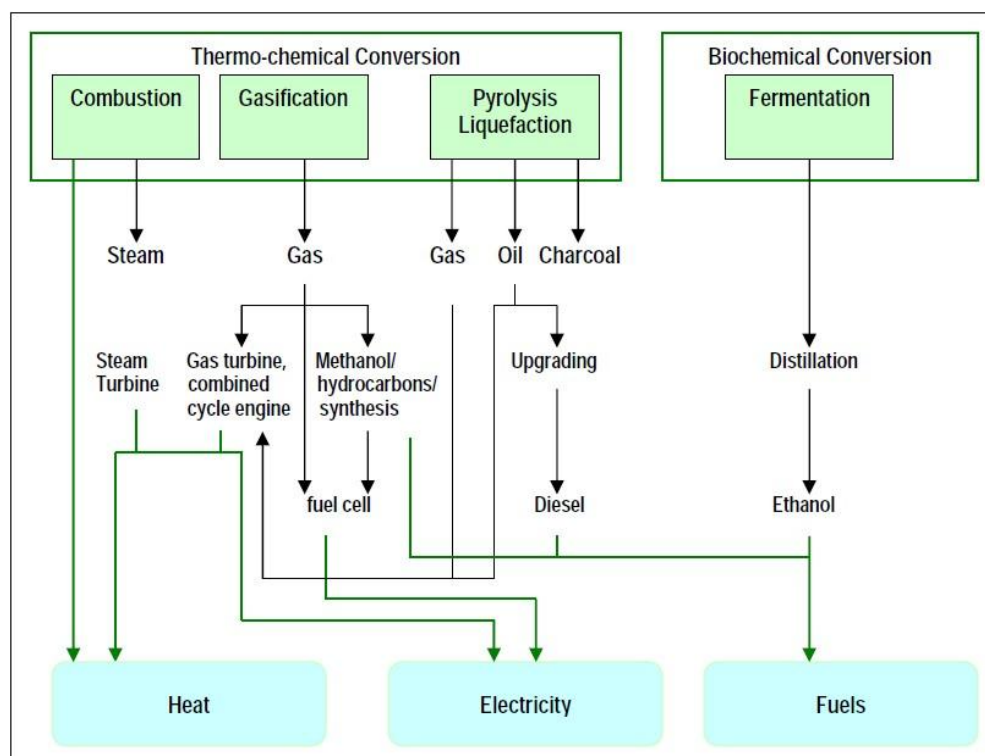

Figure 2.2: Conversion Routes for Agricultural Biomass Waste

Source: United Nations Environment Programme, 2009

Table 2.6: Residue-wise Biomass in India : Based on Survey Data [2002-04] ; Season :
Agro-Kharif

Crop	Residue	Area (kha)	Crop Production (kT/Yr)	Biomass Generation (kT/Yr)	Biomass Surplus (kT/Yr)	Power Potential (MWe)
Paddy	Straw	32259.7	74940.3	112409.6	26657.6	3197.5
Maize	Stalks	5627.8	10211.9	20424.4	4153.4	539.9
Paddy	Husk	32259.7	74940.3	14988.0	10583.9	1164.2
Bajra	Stalks	8330.7	5978.3	11956.1	1894.8	246.3
Jowar	Stalks	4403.4	6212.1	10560.7	1375.4	178.8
Groundnut	Stalks	5562.0	5272.1	10544.2	1589.4	206.6
Soybean	Stalks	6060.1	5847.2	9940.2	3284.4	427.0
Arhar	Stalks	2731.6	1936.6	4841.5	773.7	100.6
Jowar	Cobs	4403.4	6212.1	3106.1	1089.9	152.6
Maize	Cobs	5627.8	10211.9	3066.5	1174.5	164.4
Tapioca	Stalks	167.5	4120.9	2966.8	2074.9	269.7
Ragi	Straw	1425.9	1925.1	2502.7	197.1	23.7
Bajra	Cobs	8330.7	5978.3	1972.8	933.1	121.3
Bajra	Husk	8330.7	5978.3	1793.4	428.2	51.4
Castor seed	Stalks	527.0	414.3	1657.2	733.8	95.4
Meshta	Stalks	477.0	802.7	1605.4	160.5	20.9
Groundnut	Shell	5562.0	5272.1	1581.6	1016.5	122.0
Pulses	Stalks	1857.9	1057.1	1374.2	137.4	17.9
Jowar	Husk	4403.4	6212.1	1242.4	608.9	73.1
Til	Stalks	1059.1	432.1	1079.6	251.9	32.7
Potato	Leaves	114.7	974.1	740.3	147.7	20.7
Gram	Stalks	1019.0	648.4	713.0	520.1	67.6
Urad	Stalks	1075.9	531.6	584.7	63.8	8.3
Small millets	Stalks	828.7	485.6	582.7	58.3	7.6
Arhar	Husk	2731.6	1936.6	581.0	290.5	34.9
Sunflower	Stalks	489.2	284.9	569.9	90.7	11.8
Moong	Stalks	779.3	401.6	441.7	44.2	5.7
Guar	Stalks	266.3	116.6	233.3	163.3	22.9
Dry chilly	Stalks	102.9	101.6	152.4	15.4	2.00
Urad	Husk	1075.9	531.6	106.3	49.7	6.0
Niger seed	Stalks	275.5	81.6	86.5	6.5	0.84
Cashew nut	Stalks	86.8	42.8	77.0	15.4	2.00
Barseem	Stalks	13.2	71.6	71.6	57.3	7.4
Onion	Stalks	120.1	1330.0	66.5	7.1	0.99
Moong	Husk	779.3	401.6	60.2	12.0	1.44
Potato	Stalks	114.7	974.1	48.7	11.9	1.54
Cow gram	Stalks	55.3	43.2	47.5	4.75	0.62
Horse gram	Stalks	82.8	35.5	46.2	4.62	0.60
Castor seed	Husk	527.0	414.3	41.4	20.7	2.49
Meshta	Leaves	477.0	802.7	40.1	4.01	0.48
Oilseeds	Stalks	14.7	19.8	39.7	7.9	0.95
Turmeric	Stalks	33.6	75.5	22.3	11.2	1.45
Cashew nut	Shell	86.8	42.8	21.4	4.28	0.56
Moth	Stalks	18.0	9.9	17.8	1.78	0.23
Sannhamp	Stalks	5.2	5.6	14.1	1.41	0.18
Sweet potato	Stalks	18.4	127.8	12.8	1.28	0.17

Kesar	Stalks	6.0	6.9	7.3	5.8	0.70
Peas & beans	Stalks	18.2	14.5	7.2	0.72	0.094
Masoor	Stalks	6.2	3.69	6.6	0.66	0.086
Linseed	Stalks	6.6	3.65	5.4	0.54	0.070
Dry ginger	Stalks	20.2	102.7	5.1	0.51	0.067
Kodo millets	Stalks	4.30	2.70	3.13	2.51	0.33
Others	Others	6.6	2.44	2.33	0.64	0.084
Sawan	Stalks	0.32	0.22	0.22	0.18	0.089
Total		75957.9	124675.4	225070.0	60746.6	7416.8

Source : National Biomass Resource Atlas of India

Paddy is major kharif crop. Table 2.6 shows the power potential of various kharif crops. The power potential of Kharif crops is 7417 MWe (Megawatt electrical).

Table 2.7: Residue-wise Biomass in India - Year : Based on Survey Data [2002-04] ;
Season : Agro-Rabi

Crop	Residue	Area (kha)	Crop Production (kT/Yr)	Biomass Generation (kT/Yr)	Biomass Surplus (kT/Yr)	Power Potential (MWe)
Wheat	Stalks	22130.8	62241.0	93361.7	16176.3	2102.9
Wheat	Pod	22130.8	62241.0	18672.3	8382.3	1173.5
Paddy	Straw	8957.9	25039.7	37559.5	3936.7	472.4
Mustard	Stalks	4030.3	3887.9	6998.2	3173.9	412.6
Paddy	Husk	8957.9	25039.7	5007.9	2360.2	259.6
Mustard	Husk	4030.3	3887.9	1674.7	1591.0	190.9
Jowar	Cobs	4859.6	3874.8	1937.4	822.1	115.1
Tapioca	Stalks	38.3	1378.1	992.2	694.6	90.3
Jowar	Stalks	4859.6	3874.8	6587.2	667.4	86.8
Gram	Stalks	4985.0	4068.6	4727.6	494.0	64.2
Groundnut	Stalks	753.8	1302.0	2603.9	477.5	62.1
Safflower	Stalks	320.5	179.8	539.3	431.4	56.1
Maize	Stalks	670.6	1498.4	2996.9	394.4	51.3
Jowar	Husk	4859.6	3874.8	775.0	350.9	42.1
Groundnut	Shell	753.8	1302.0	390.6	183.7	22.0
Maize	Cobs	670.6	1498.4	469.9	145.4	20.4
Cumin seed	Stalks	306.3	117.8	182.6	146.1	17.5
Sunflower	Stalks	852.2	418.8	837.7	116.6	15.2

Oilseeds	Stalks	404.6	551.7	1103.5	110.3	13.2
Masoor	Stalks	381.5	329.8	593.6	90.5	11.8
Barley	Stalks	226.7	433.2	563.2	57.5	7.5
Arhar	Stalks	105.3	111.5	278.7	48.3	6.3
Til	Stalks	174.4	51.2	128.0	30.6	3.98
Bajra	Stalks	34.1	41.7	83.3	24.7	3.21
Moong	Stalks	569.9	208.4	229.3	22.9	2.98
Ragi	Straw	62.2	98.1	127.6	23.9	2.86
Potato	Leaves	4.93	121.2	92.1	18.4	2.58
Urad	Stalks	447.8	179.9	197.9	19.8	2.57
Coriander	Stalks	140.0	162.8	187.2	18.7	2.43
Urad	Husk	447.8	179.9	36.0	17.9	2.15
Arhar	Husk	105.3	111.5	33.4	15.9	1.91
Horse gram	Stalks	335.6	111.6	145.1	14.5	1.89
Dry chilly	Stalks	42.9	77.5	116.2	13.4	1.74
Moong	Husk	569.9	208.4	31.3	13.8	1.66
Cashew nut	Stalks	39.6	12.0	21.6	10.8	1.41
Linseed	Stalks	161.7	55.1	81.0	8.1	1.05
Bajra	Cobs	34.1	41.7	13.7	6.9	0.89
Turmeric	Stalks	6.0	33.2	10.0	4.98	0.65
Potato	Stalks	4.93	121.2	6.1	3.03	0.39
Peas & beans	Stalks	62.1	40.3	20.1	3.01	0.39
Cashew nut	Shell	39.6	12.0	6.0	3.01	0.39
Bajra	Husk	34.1	41.7	12.5	3.13	0.38
Small millets	Stalks	11.8	14.4	17.3	1.73	0.23
Pulses	Stalks	14.8	12.5	16.2	1.62	0.21
Kesar	Stalks	4.44	1.97	2.07	1.66	0.20
Others	Others	24.8	9.7	8.6	0.28	0.037
Total		51160.3	106664.7	190476.3	41133.9	5329.9

Wheat is major rabbi crop. Table 2.7 shows the power potential of various rabbi crops. The power potential of rabbi crops is 5330 MWe (Megawatt electrical).

2.4 Power Generation in Punjab using Agro-Waste

In agro-waste power generation plants, agro-waste with high calorific value are used as fuel in boilers to produce electricity. Biomass/Agro-waste based power projects have attracted the attention of State and Central Government and also have been given priority due to short gestation periods for production of agro-waste, smaller quantum of investment, reduced transportation losses, etc.

In Punjab, straw management is one of main problem faced by farmers after rice harvesting. Around 6 tonne of straw is produced per hectare of rice cultivated. Punjab Energy Development Agency (PEDA) estimated that agro-waste in Punjab is sufficient to produce about 1000 MW of electricity and can fulfil 20% of the state's demand. Punjab government had decided to set up 36 Agro-waste power plants, with total capacity of 350 MW [16]. Jalkheri power plant (10MW), Malwa Power Ltd. at Vill. Gulabewala, Distt. Mukatsar (6MW), Dee Development Engineers Pvt. Ltd at Vill. Gadda Dhob, Distt Ferozepur (8MW) are few of operating agro-waste based power generation plants.

Agro-waste plants have high life cycle energy balance than thermal plants. Since agro-waste is not considered as a traditional source of energy, it is estimated that 16 units of energy is produced by consuming one unit of energy, whereas thermal plants produces 0.3 units per unit of energy [17]. In a laboratory study of agro-waste open field combustion, emission factors of CO₂, CO, NO, NO₂ and NO_x were measured to be 791.3, 64.2, 1.02, 0.79 and 1.81 gram/kilogram respectively for paddy straw [11]. In an analysis, it was observed that the overall emission reductions of about 92-96% of CO₂-eq can be achieved if paddy straw is substituted for the coal fuels in the power generation. Emission reduction can be 0.683 tCO₂-eq/t straw (dry-based paddy straw) or 0.959 kg CO₂-eq/kWh. Similarly in case the paddy straw is substituted for natural gas, then the emission reduction is 0.368 tonne CO₂-eq/tonne straw (dry-based paddy straw) or 0.496 kg CO₂-eq/kWh. Also, this would result in the saving fossil fuels i.e. 0.285 t coal per 1 tonne of dry base rice straw [18]. While making these calculation it was assumed that no further amount of emissions occur in agro-waste based thermal plant, only same amount of emission is produce as during open field burning of paddy straw. That is why agro-waste based thermal plants are called zero emission plants. The additional amount of

CO₂ emission on account of transportation and pre-processing the straw is responsible for the CO₂ emission reduction being less than 100%.

2.5 A CASE STUDY

Jalkheri power plant (10 MW) was constructed at village Jalkheri, District Fatehgarh Sahib in Punjab by Punjab State Electricity Board (PSEB) in the year 1992 with paddy straw as fuel. The plant was set up to utilize the surplus agro-waste available in the region for effective and clean generation of electricity for supply to PSEB grid. The project exports around 8.4 MW power to the PSEB grid by considering auxiliary power consumption of 11%, on an annual average basis. The project reduces the green House Gas (GHG) emissions produced by the state grid generation mix, which is mainly dominated by fossil fuel based power plants.

Table 2.8: Jalkheri Power Plant Specifications [20]

S. No.	Particulars	Unit	
1	Installed Capacity	kW	10 x 10 ³
2	Cost of Project	Lacs	6600
3	Cost/kW 220000000/2 x 10 ³	Rs.	66000
4	Interest on capital during const. @ 8% (2)	Lacs	528
5	Total of (2 + 4)	Lacs	7128
6	Cost/kW including interest charges (5/1)	Rs.	71280
7	Annual generation per kWh at 70 LF 7000 x 365 x 24	kWh	61320000
8	Auxiliary Consump @ of 5% of (7)	kWh	306.6
9	Units sent out (7 – 8)	kWh	5825.4
10	Weighted heat rate (10876.8 x 1.14)	kJ/kWh	14832
11	Fuel Consumption	Kg/kWh	1.14
12	Fuel Consumption per year kW (11 x 7)	Kg	6990.48
13	Annual fuel cost/kW installed @ 1500/tonne 599184x1500/1000	Rs	5941.908
14	Fixed Charges (a) Interest Charges @ 8% on 6 5702.4 (b) O & M charges @ 2.5% on 3 1650.0 (c) Dep. @ 3.5 % on 3 2310.0	Rs.	9662.4
15	Total fixed & running charges (13 + 14)	Rs.	16303.356
16	Cost/kWh generated (15/7)	Rs.	2.641
17	Cost/kWh at bus (15/9)	Rs.	2.78
18	Return on capital	Rs.	761.60
19	Profit/Unit sent out (18/9) 3850/4993.2	Rs.	0.1307
20	Price/kW generated for sending out (17 + 19)	Rs.	2.91

Table 2.9: Fuel Required Per Unit [20]

Fuel Required/Unit			
1	CV of the fuel	kJ/kg	14832
2	Boiler η_b		80%
3	Heat available 13596×0.80	kJ/kg	11865.6
4	Requirement of fuel/unit	Kg/kWh	1.14
5	Total annual generation at 70% LF	kWh	61.32×10^6 kWh
6	Total requirement of fuel/year	MT	70000
7	Requirement of fuel/day	MT	191.780
8	Requirement of fuel/hr	MR	8 mt/h/MW

$$\text{Heat Rate} = 11865.6 \times 1.14 = 13526.784 \text{ kJ/kg}$$

It was observed that during second monitoring period i.e. 01/10/2006 - 31/08/2007 the total emission reduction is 21,940 t CO₂ e [19]. Despite the abundant availability of Biomass, because of uncertainties of supply and pricing of agro-waste, the unavailability of agro-waste can hamper the operation of plant. In order to ensure adequate raw-material for the plant a consortium of following type has been formed:

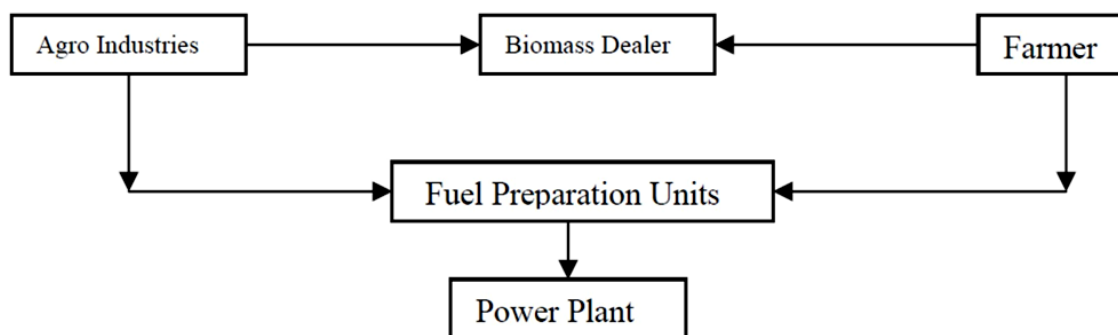
**Figure 2.3:** Availability of Agro-Waste [5]

2.5.1 Problems Faced by Agro-Waste Power Generation Plant

Some problems faced by the agro-waste based power generation plant during operation of plants are:

Fuel availability: Crop residue are available seasonally. The unavailability of agro-waste can hamper the operation of plant. Late payment to the agriwaste suppliers and farmers due to problems of working capitals, also caused short fall of fuel [20].

Fuel price: Uncertainties and rise in prices of agro-waste, increasing the per unit cost of generation.

Fuel Properties: Agro-waste like paddy straw contain high amount of silica content and has alkaline nature that cause slagging and clinkerisation in the boiler. Firing of high chlorine fuels results in super heater tubes corrosion and ash agglomeration. Because of low melting point of paddy straw ash, boiler temperature has to be kept below the melting temperature of ash, results in inefficient working of boiler. Agro-waste has low calorific value and is voluminous than other conventional fuels.

Fuel handling: Improper handling and storage of agro-waste fuel increase the moisture content in fuel, results in decreased boiler temperature.

Transportation emission: Transportation of agro-waste from field to plant site cause gas emission. The emissions due to transportation of Biomass/ agro-waste have been accounted as leakage.

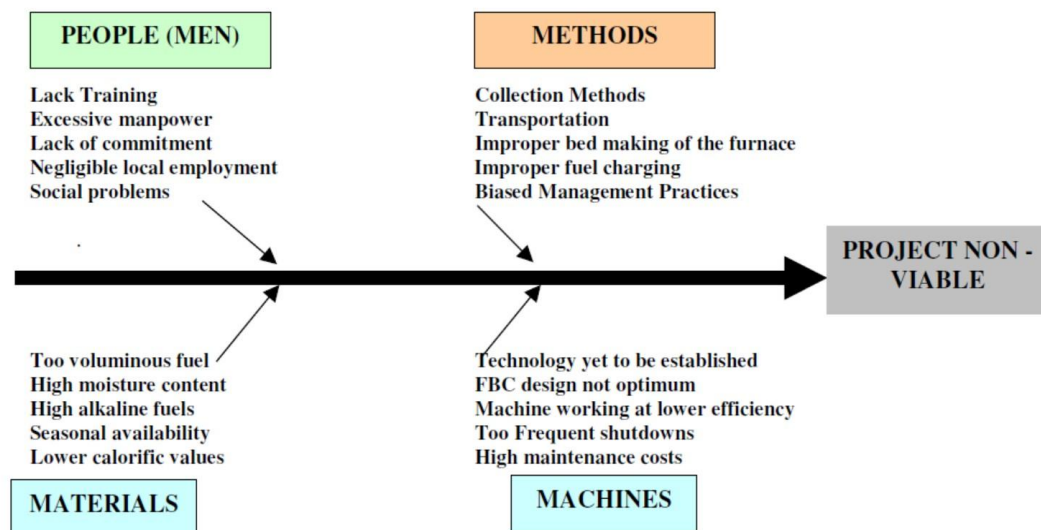

Figure 2.4: Causes and Effect Diagram [14]

2.6 Pollution by Agro Waste Power Plants

Agro waste power generation is better alternative to thermal power generation but scale of generation is limit. Others risk factor discussed earlier faced during power generation. In order to reduce the total power cost and to meet the increased power requirement of the main plant, agro power plant can be installed as a Co-Generation Power Project in Agro industries. Like all other power plants, these plants also produce pollution i.e.

- Air pollution
- Water pollution
- Noise pollution

The pollutants generated from the power plant include:

- Dust and particulate matter in the flue gas
- Fly ash from the hoppers
- Furnace bottom ash
- Effluent from water treatment plant
- Sewage from the plant
- Noise pollution in the power plant is from rotating equipments, feed pumps, and boiler and super heater safety valves, start up vent, steam turbine etc [19].

2.7 Alternative to Power Generation

Agro-waste power generation faces many problems for proper and continuous operation as discussed earlier. Agro-waste have some nutrients in them which can be utilized but these get destroyed while burning it to produce electricity. The major flaw in this philosophy is the assumption that the agro-waste is anyway burnt in the open field. There are other alternative also to utilize agro-waste beneficially, instead of burning in the open field. These are listed as:

Mulching: Covering the soil with agro-waste is called organic mulching. Mulching helps in saving water, suppressing weeds, protecting against high temperature, reducing erosion, retaining moisture, providing nutrients [21].

Manure: Agro-waste can be decomposed to make manure or can be used in bio gas plants which will produce gas for household use and its by-product manure can be used in field to increase soil fertility.

Cattle fodder: Agro-waste is usually used as ruminant fodder, with the exception of paddy straw because of high silica content and low cellulose and other sugar contents.

Biomass gasifiers: In biomass gasifiers solid agro-waste is converted into gaseous fuel. The producer gas obtained by the gasification can be used for mechanical or electrical power generation or for thermal application.

Because of difficulties faced by agro-waste power generation, other alternative should be adopted to utilize and attenuate the straw management problem of the farmers. Considering the benefits and low labour cost, mulching could be a better alternative.

Chapter 3

Mulching

3.1 Mulching

Mulching technically means covering of soil. Mulch provide the conditions that are favourable for the growth of plant and crop production. We can say that any substance spread on the farm to protect the plants and crops is called mulch. Mulch can be organic or inorganic. Agro-waste can be used as organic mulch. Agro-waste usually used for mulching are paddy straw, rice husk, bagasse, ground nut shell, sawdust, soybean husk, cotton stalk, sunflower husk, jute waste, chana husk etc. Mulch helps in saving water use for irrigation by keep the watering frequency down, suppress weeds, protect against high temperature, reduce erosion, retain moisture, provide nutrients.

3.2 Types of Mulching

Mulching is the process of covering the ground to protect and provide favourable condition for the plant growth and crop production. Types of mulches are.

3.2.1 Organic Mulches

Organic mulches are those mulches which are made out of natural substances. Organic mulches are provide nutrients and enrich the soil as decays. Agro-waste like paddy straw is fall in the category of organic mulch. Over the time, organic mulches will decompose and become part of the soil and adds organic matter to soil, helping the soil to better retain water and nutrients, results in healthier plants. The organic mulches are temporary and will have to be replenished from time to time as it decompose with time.

Straw: Straw from rice, wheat, barley and other crops is widely available after harvesting. Straw is inexpensive and normally sold in compressed bales. It is then prepared and chopped in different sizes according to requirement. Straw mulch is light in weight and easy to apply and use. It is used as winter mulch around tree or shrub roots

and as summer mulch in vegetable gardens and strawberry plantings. Nowadays, Paddy straw is used for mulching on fields, it provide better conditions for crop cultivation. Straw has some potential problems when used as mulch.



Figure 3.1: Straw Mulching

Straw mulches are highly flammable, contains grain seeds that can germinate, it lowers the soil nitrogen supply as it decomposes and have to replenished annually. Dry paddy straw can be easily blown by wind. On the other hand, it is cheap and effectively suppresses weeds, reduces soil water losses, conserves moisture, and insulates well. They are biodegradable and neutral in pH

Bark mulches: Bark Mulches are prepared from the by-products of pine, hardwood logs or cypress. Bark mulches resist soil of compaction. Like light weight mulches, it will not blow away. These mulches are very attractive and are readily available. Bark mulches decompose slowly, therefore will have not to be replenished from time to time as other mulches.

Wood chips: Wood chips are made by reprocessing used timber and many different kinds of trees. Wood chip mulches may contain seeds from trees and other plants that can sprout and create weed problems, wood mulches should be properly aged or composted. Mulch that has not been aged, form organic acids during the decomposition process, and could kill or tender stem of young plants. Wood chip mulches have a high carbon : nitrogen ratio, it may temporarily reduce the supply of soil nitrogen for plant uptake

during mulch decomposing. This loss can be compensated by adding nitrogen fertilizer to mulched plants/crop. It is practiced to replenish wood mulches every 2 to 3 years.

Sawdust: Sawdust is a by-product of wood processing. Sawdust mulch is recommended for acid-loving plants like blueberries, rhododendrons etc. Sawdust is low in nitrogen, so it can rob nitrogen from the soil as it decomposes like wood chips. To compensate this loss, nitrogen fertilizer may be needed. Because of compaction and decomposition of sawdust layers, it is necessary to fluff up and replenish sawdust mulch each season.

Pine straw: Pine straw acidifies the soil like sawdust mulch and is used for acid-loving plants. Pine needles decompose slowly, are resistant to compaction, resistant to washing away and are easy to work with. Pine straw mulch is usually not available commercially. Pine needles should be renewed annually.

Shredded leaves. Leaves have been shredded before using as mulch, otherwise they form a mat and block water movement into the soil that blocks free water and oxygen movement into the soil. To avoid this, leaves should be allowed to undergo partial decomposition before using them as mulch. Shredded leaves mulch contribute nitrogen, and other nutrients to the soil while decomposing.

3.2.2 Inorganic Mulches

In inorganic mulches, black sheets are used to cover the plants and crop to protect it from the environment, moisture retention, weed suppression. Inorganic mulches do not rob nitrogen from the soil, like sawdust and wood chip mulch. But these mulches do not provide organic matter like nitrogen and other nutrients to soil. Inorganic mulches cannot be used for acid-loving plants. Inorganic mulches like plastic mulches are difficult to remove.

Plastics: In plastic mulching, fields are covered with plastic sheets and crops grow through holes in thin plastic sheeting. Plastic mulching is best reserved for large-scale vegetable growing. Disposal of plastic mulch is cited as an environmental problem. This mulching helps in weed suppression and retaining soil moisture. It prevents water from leaving the soil but it also prevents it from entering the soil. This is acceptable in crop

plantings where rows covered with black plastic are normally alternated with rows of bare ground.



Figure 3.2: Plastic Mulching

Geotextiles: Geotextiles mulch are fabric mulches of polypropylene or polyester. They work much as plastic does, but allow water and fertilizer to enter the soil. The ultra violet rays of sun could do damage to the fabric. Fabric mulching is usually more expensive than other.

Characteristics of good mulching is that it should be economical, available, environmental friendly, provide nutrients to soil, free from weeds and insects and not rob nutrients from soil. All these condition are fulfilled by paddy straw.

3.3 Benefits of Mulching

Mulching has various benefits and could be a attractive alternative to power generation, using crop residue like paddy straw. Since it is used in the field site itself that will minimize transport and labour cost. The other benefits of mulching are:

Water Saving: Mulching reduce the evaporation process in the irrigated land as it helps the soil to retain moisture for long time than un-mulched soils. Mulching helps in protecting fields against water erosion and increase the duration of first-stage drying. Mulching reduces the runoff velocity of water. The amount of water saving and retention

is proportional to amount of straw mulch [22],[23]. According to Singh R.P. et al. (2008) mulching saves 30% of irrigation water as shown in table 3.1. This would help save 168kWh/ha of electricity used by submersible motors for pumping water [13].

Table 3.1: Water saving with mulching and tillage method of irrigation.

Irrigation	Conventional sown wheat (cm/irrigation)	With Mulching and tillage method(cm/irrigation)	Water saved
Pre-irrigation	10	0	100%
First irrigation	7.5	6.38	15%
Second irrigation	7.5	6.75	10%
Third irrigation	7.5	7.5	0%
Fourth irrigation	7.5	7.5	0%
Total	40	28.1	30 %

Source: Singh R.P. et al. (2008) [3]

Weed suppression: Weed is a plant that has no value and it hinders the growth of main plant or crop. The rice straw mulch is effective in weed management [24]. Devasinghe *et al.* (2011), illustrated that the mulching with rice straw at the rate of 4t/ha was effective in weed suppression under Direct Seeded Lowland Rice method [25]. Mulching helps weed suppression by stopping light from reaching it. Because of lack of adequate amount of light they can't photosynthesize and are not able to grow.

Temperature control: Mulching affects the soil temperature by changing the amount of radiant energy balance and insulation [26]. The radiant balance is affected by amount of light that reaches the surface and is reflected by mulch. The insulation effect of residues is determined by the amount of mulch used [27]. In summers or hot season mulch is beneficial for crop production. Soil temperature is lower by the mulch [28]. Mahajan *et al.* (2007), illustrated that the mulching with plastic sheet and paddy straw keeps the temperature lower than that of un-mulched field as shown in table 3.2 [29].

Table 3.2: Effect of plastic and paddy straw mulching on soil temperature [29].

Date	Maximum temperature (°C)				Minimum temperature (°C)			
	Air	Bare soil	Plastic covered soil	Rice straw covered soil	Air	Bare soil	Plastic covered soil	Rice straw covered soil
Nov. 12	28.5	29.6	26.5	27.0	11.2	14.2	18.8	15.8
Nov.27	23.4	25.5	23.0	23.5	9.7	12.8	16.0	14.0
Dec. 12	23.1	23.9	21.5	22.8	8.8	10.4	14.0	12.5
Dec. 27	17.5	19.9	18.0	20.4	9.2	11.6	15.4	13.4
Jan. 11	15.9	19.5	18.4	19.0	5.8	8.5	11.0	10.4
Jan. 26	18.0	19.6	18.5	19.0	9.4	11.1	15.4	13.4
Feb. 10	18.6	20.1	18.0	19.5	6.6	7.8	15.2	12.7
Feb. 25	24.0	24.9	23.9	24.0	9.5	11.1	15.8	13.5
March 11	27.4	30.4	29.8	29.8	11.8	14.1	18.0	15.9
March 26	32.5	35.8	35.5	34.0	15.7	19.0	22.4	19.7
April 10	36.8	41.3	41.0	39.8	17.5	21.7	25.0	22.4

Soil erosion prevention: Mulch helps in preventing soil erosion by cover the soil. Soil erosion cause loss of soil fertility by eroding top soil, loss of soil organic matter, and decreased water –supplying capacity. Mulching of crop residue on fields, reduced erosion . Mulching reduced the runoff velocities of water and improving permeability of the soil by protecting the structure of the soil at the surface. Mulching prevent crusting and sealing of the soil surface [30].

Fertilizer: The organic mulches like paddy straw and rice husk are rich in nitrogen, silicon and potassium. About 40 percent of the nitrogen (N), 40 to 50% of the sulphur (S), 80 to 85% of the potassium (K), 30% to 35% of the phosphorus (P), and is given by paddy straw for the growth of plant and crop maturity [31]. During rain, potassium in the paddy straw get leached in the soil.

More Yield: Mulching increases the soil pH value which is an important factor effecting soil fertility. Low pH of soil convert the nutrients into forms that are not readily available to the crop and it also increase the solubility of plant toxic metals like aluminium that results in hampered growth and a general lack of plant's physical strength. In some cases because of weed reduction, yield of crop increases. The yield increase on mulches is attribute to the decreased levels of weeds due to use of mulches [32]. Mahajan et al. (2007), study revealed that bed planting of baby corn caused 34.9% increase in yield over ridge planting method. Plastic mulch increased baby corn yield by 18.9% and 77.5% over rice straw and unmulched treatment respectively [29].

Environmental friendly: Mulching agro-waste in fields is environmental friendly instead of burning them in open. Burning of crop residue cause los of nutrients present in residues. Study observed that One tonne straw on burning releases 60 kg CO, 1460 kg CO₂, 199 kg ash, 2kg SO₂ and 3 kg particulate matter [33].

3.4 Mulching as Alternative

In agriculture predominated countries, The abundant of crop residue after harvesting results in agro-waste management. A good amount of agro-waste is burnt in the open field. Burning of crop residues like paddy straw and rice husk after crop harvesting cause emission of green house gasses. Agro-waste management is a big challenge for farmers. Paddy straw is available in significant quantities to farmers after the rice crop harvesting. Management of this rice straw is a major problem. Around 6 tonne of straw is produced per hectare of rice cultivated [13]. Paddy straw usually not used as ruminant fodder because of low protein, high silica content and lignin results in low digestibility[24].

For the management of agro-waste one way adopted is to produce electricity using this agro-waste as fuel. But Agro-waste power generation faces majors risks like fuel availability and unstable prices, problems of ash melting, slagging, clinkeriation at the base of boilers, super heater choking, agglomeration and drop in boiler temperature due to moisture in the bales. All these problems results in frequent shut downs of the plants and they do not operate continuously. Transportation of agro-waste from fields to power generation plants add to gas emission and labour cost. The other alternative for efficiently utilisation of agro-waste like paddy straw and rice husk is mulching.

The problem of agro-waste management could be attenuate by using agro-waste for mulching. Mulching is other alternative that can be adapted by farmer because of its benefits and low labour cost. Mulching is an ecological approach to utilize the crop residue and agro-waste. Mulching help the soil to retain moisture, weed suppression, temperature control, act as a fertilizer, increase yield in some crops. Mulched soil reduce the soil evaporation and save irrigation water that results in electricity saving by reducing the water pumping time. It is concluded that mulching save the irrigation water by increasing soil moisture retention.

Study can be conducted to compare the use of agro-waste by mulching it on the field rather than burning in power plants to generate electricity. The amount of electricity saved on account of moisture retention due to mulching may be a significant fraction of that produced by burning it in agro-waste based thermal plants. Further study can be conducted to determine the optimal amount of mulching to save the irrigation water, because excess use of crop residue is also not beneficial from economical point of view.

Chapter 4

Literature Review

Literature surveyed unfolds the scenario of agro waste and various method of its utilisation and management at the world level. Many studies are conducted on proper management of agrowaste and convert it into energy resource. For the management of agro-waste one way adopted is to produce electricity using this agro-waste as fuel. But Agro-waste power generation faces majors risks. Diverse aspects of the problem have been examined and the results of studies reported at national and international level. One of the methods with more benefit potential is to use agro waste on field itself by mulching. Mulching is an ecological approach to utilize the crop residue and agro-waste. Mulching helps to retain moisture in soil and further, mulching the fields reduces soil evaporation and save irrigation water that indirectly results in electricity saving.

Sidhu K.S. *et al.* (2010) has describes in brief the non conventional energy sources and their usage in India with a case study of Punjab State. The primary source of energy is fossil fuel, however the finiteness of fossil fuel reserves is degrading because of their widespread use. Large scale environmental degradation, particularly caused by global warming, urban air pollution and acid rain, strongly suggests that practicing of non-conventional, renewable and environment friendly energy resources for power generation, is vital for steering the global energy supplies towards a sustainable path [3].

Singh Yadvinder *et al.* (2010) concluded that rice residue retention has a significant positive effect on soil fertility and biological properties of soil. Sowing wheat in paddy straw mulched fields without presowing irrigation will save about 20% in irrigation water, which would help to save 80 kWh of electricity and 160 kg of CO₂. Soil organic matters build up, when crop residues are returned to the fields by mulching. It was observed that paddy straw mulching has not been beneficially effect yield of the following wheat crop while grain yield of next rice crop increased after 2-3 years. The mulching of paddy straw is beneficial in soils with heavy texture and in the areas where irrigation water is briny in nature or soils are sodic in nature [7].

Agrawal S et al. (2006) observed that the field burning of paddy straw is a major contributor to air pollution and human respiratory ailments in the areas of intensive rice production. Substantial loss of plant nutrients and organic carbon also occurs during burning of crop residues which has important implications for soil health. Field burning smoke contains fine particulates matters, which can be inhaled deep into lungs and can cause serious respiratory problems. Burning agro-waste on the fields is a rapid, cheap option which allows quick turnaround between crops, hence more than 90% of the 17 Mt of rice stubble in Punjab is burnt each year [8].

Zhang Hefeng et al. (2008) conducted a laboratory study of agricultural crop residue combustion in China and calculate emission factors and emission inventory. In this study of agro-waste open field combustion, emission factors of CO₂, CO, NO, NO₂ and NO_x were measured to be 791.3, 64.2, 1.02, 0.79 and 1.81 gram/kilogram respectively for paddy straw [11].

Samra J.S et al. (2003) described that burning is the most cost-effective and predominant method of disposal in areas under combined harvesting. Usually, farmers burn the residue in open to clear the land quickly for next crop. This paper has calculated greenhouse gas emission from burning of rice straw in northwest India.

Singh R.P et al. (2008) had made economic assessment of the mulching for rice-wheat systems in Punjab, India. Agro-waste management is a big challenge for farmers. Paddy straw is available in significant quantities to farmers after the rice crop harvesting. Management of this rice straw is a major problem. More than 6 tonne of straw is produced per hectare of rice cultivated. The study has identified some important health, community and environmental benefits from the widespread adoption of the mulching. It estimates potential financial benefits to farmers of mulching as compared to open burning of paddy straw. According to this paper, mulching saves 30% of irrigation water. This would help save 168kWh/ha of electricity used by submersible motors for pumping water. He yet not had been able to put monetary value on any of these benefits [13].

Sharma P.K. et al. (2008) describes the effect of crop residue management practices and green manuring on nutrient dynamics and soil productivity in rice-wheat cropping system. According to paper, 89% of N, 19% of K and 25% of S is lost due to burning of the rice crop residue i.e. paddy straw [14].

Mann Margaret K. et al. (1999) conduct a study on life cycle comparison of electricity from agriwaste and coal and concluded that agro-waste plants have high life cycle energy balance than thermal plants. Since agro-waste is not considered as a traditional source of energy, it is estimated that 16 units of energy is produced by consuming one unit of energy, whereas thermal plants produces 0.3 units per unit of energy [17].

Delivand Mitra Kami et al. (1999) had done overall Analyses of Using Rice Straw Residues for Power Generation in Thailand- Project Feasibility and Environmental GHG Impacts Assessment. In this analysis, it was observed that the overall emission reductions of about 92-96% of CO₂-eq can be achieved if paddy straw is substituted for the coal fuels in the power generation. Emission reduction can be 0.683 tCO₂-eq/t straw (dry-based paddy straw) or 0.959 kg CO₂-eq/kWh. Similarly in case the paddy straw is substituted for natural gas, then the emission reduction is 0.368 tonne CO₂-eq/tonne straw (dry-based paddy straw) or 0.496 kg CO₂-eq/kWh. Also, this would result in the saving fossil fuels i.e. 0.285 t coal per 1 tonne of dry base rice straw [18].

Lonia B. et al. (2005) had studied techno economic aspects of power generation from agriwaste in India. The study described the possibility of utilizing the agro-waste as fuel in various combinations, particularly for power generation purposes. The study involved scanning for agro-waste for the main crops of the region; finding the calorific values and other related parameters for some of the materials used as fuel supplements and binders. Case study of the two agriwaste power generation plants; briquetting of agriwaste in various combinations and finding their related parameters; designing and fabricating a fluidized bed combustor and testing all the composite fuels prepared for their thermal efficiency that improved from 20-25% and environmental sustaining/improvement efforts. Linear programming studies were done to find fuel mixes that would have a minimum unit cost and still have calorific value more than 16800 kJ/kg.(4000 kCal/kg) [20].

Mulumba and Lal *et al.* (2008) found that wheat straw mulch significantly increased available water capacity and soil moisture content and field capacity. Mulch provide the conditions that are favourable for the growth of plant and crop production [21].

Gill B.S. *et al.* (1996) provide information on evaporation and its reduction by crop residues mixed mulching on the soil to different depths in relation to soil texture and evaporativity. this paper studied the effect of four rates of paddy straw mulching, viz. 0,2,4 and 8 Mg ha⁻¹ and mixed mulch in soil to two depths i.e. 2 and 5 am under two evaporativity viz. 2.0 ± 0.5 and 8.7 ± 1.5 mm day⁻¹ in silty clay loam and sandy loam soil columns of 0.95 m length and 0.1 m diameter. Mixing of residue in the surface soil layer not only reduced evaporation but also resulted in higher water content in the near surface soil after drying [22].

Devasinghe K.P. *et al.* (2011) illustrated that the mulching with rice straw at the rate of 4t/ha was effective in weed suppression under Direct Seeded Lowland Rice method. The paper described that mulching helps weed suppression by stopping light from reaching it. Because of lack of adequate amount of light they can't photosynthesise and are not able to grow [25].

Hay R.K.M. *et al.* (1977) and Dao T.H *et al.* (1993), illustrated that mulching affects the soil temperature by changing the amount of radiant energy balance and insulation. The radiant balance is affected by amount light reaching the surface and reflected by mulch. The insulation effect of residues is determined by the amount of mulch used. In summers or hot season, mulch is beneficial for crop production, as it keeps the soil temperature low [27],[28].

Mahajan Gulshan *et al.* (2007) studied the effects of plastic mulch on economizing irrigation water and weed control in baby corn sown by different methods. It illustrated that the mulching with plastic sheet and paddy straw keep the temperature low than that of un-mulched field. Study revealed that bed planting of baby corn caused 34.9% increase in yield over ridge planting method. Plastic mulch increased baby corn yield by 18.9% and 77.5% over rice straw and unmulched treatment respectively [29].

Gupta Prabhat K et al. (2000) described that mulching agro-waste in fields is environmental friendly instead of burning them in open. Burning of crop residue cause los of nutrients present in residues. Study observed that One tonne straw on burning releases 60 kg CO, 1460 kg CO₂, 199 kg ash,2kg SO₂ and 3 kg particulate matter [33].

Evans Robert et al. (1996), illustrated various monitoring methods and devices for measuring soil water for irrigation scheduling. It described di-electric methods like time domain reflectometry (TDR) and frequency domain reflectometry (FDR), tensiometer and electrical resistance blocks for the measurement of moisture percentage present in soil.

Chapter 5

Problem Definition

Agro-waste power generation faces many problems for proper and continuous operation as discussed earlier. Agro-waste have some nutrients in them which can be utilized but these get destroyed while burning it to produce electricity. Agro-waste based thermal power generation is considered to be zero emission power generation. While making these calculation it was assumed that no further amount of emissions occur in agro-waste based thermal plant, only same amount of emission is produce as during open field burning of paddy straw. That is why agro-waste based thermal plants are called zero emission plants. The additional amount of CO₂ emission on account of transportation and pre-processing the straw is responsible for the CO₂ emission reduction being less than 100%. The major flaw in this philosophy is the assumption that the agro-waste is anyway burnt in the open field. There are other alternative also to utilize agro-waste beneficially, instead of burning in the open field. These options need to be explored objectively.

Mulching is other alternative that can be adapted by farmer because of its benefits and low labour cost. Mulching is an ecological approach to utilize the crop residue and agro-waste. Mulching helps to retain moisture in soil, to suppress weeds, to control temperature of soil, to act as a fertilizer and to increase yield in some crops. Further, mulching the fields reduces soil evaporation and save irrigation water that indirectly results in electricity saving. The amount of mulch in the field requires to be optimised.

Mulching consumes huge amount of agro-waste. Presently, the use of agro-waste for power generation is being promoted by many states. However, this normally leads to pollution of air and wasteful destruction of many nutrients required by the plants. It is proposed that the water saved on account of moisture retention saves considerable amount of electricity. As an alternative to power generation, if this agro-waste is used for mulching, the fraction of power generated by agro-waste can be saved by mulching, on account of decreased irrigation. This fraction needs to be quantified.

Chapter 6

Methodology

This study is conducted to compare the use of agro-waste by mulching it on the field rather than burning in power plants to generate electricity. The amount of electricity saved on account of moisture retention due to mulching may be a significant fraction of that produced by burning it in agro-waste based thermal plants. Aim of study is calculate the optimal amount of mulching to save the irrigation water, because excessive use of crop residue as mulch is also not beneficial from economical point of view. Also included in the study is the quantification of fraction of electricity saved on account of decreased irrigation, vis-a-vis agro-waste based power generation.

6.1 Parameters to be determined

- Optimised Value of water saved by mulching (litre/kg)
- Electricity consumed by pumping water for irrigation (kWhr/litre)

For determining the water and the electricity saved by mulching, study was conducted on plots of same size but with different mulching quantity. Plots were mulched with different amount of agrowaste to obtain optimal point of comparison. Moisture percentage of plots was measured with moisture sensor at the fixed time interval. Data of readings was maintained. Amount of electricity saved is directly proportional to water saved by reducing the pumping time per irrigation.

6.2 Methodology of the Study

Methodology adopted to conduct the study and results are as following:

6.2.1 Site Selection

This study is conducted in Village Shekhupur, district Patiala on my farm. The Site for drawing plots is such selected that all the plots get same amount of sunlight. It is

considered that there would no obstacle like trees etc to sunlight, so that all four plots should get same amount sun heat at same time. This made sure that plots were under same condition during whole study.

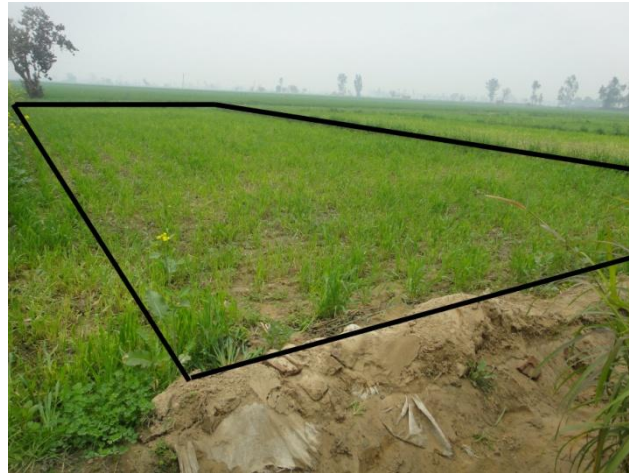

Figure 6.1: Site selected

6.2.2 Site Preparation

Selected site was then prepared for study. Land was plough with the help of tractor and yields etc were removed. Land was prepared in the same way as prepared for sowing new crop. Four plots of same size was drawn. Size of each plot was 10' x 12'. Each plot was isolated from other. Moisture of plots was measured and then required water was added to bring the moisture percentage of all plots to 95%.

6.2.3 Mulch Preparation

Paddy straw available in significant quantities to farmers after the rice crop harvesting. Paddy straw usually not used as ruminant fodder because of low protein, high silica content and lignin results in low digestibility[24]. Paddy straw length ranges from 80-120cm. For preparing mulch, we cut paddy straw in half the size, to minimize labour cost. In straw incorporation method stubble and whole straw left in field as it is, after harvesting.



Figure 6.2: Paddy Straw

6.2.4 Mulching Paddy Straw

Prepared paddy straw was weighted with weighing machine on the site. Plots was mulched with different amount of mulch to get optimal point of beneficial mulching results in saving water by retaining moisture. Mulch was spread properly of exact quantity with hands.

Table 6.1: Mulch amount during Study Part 1

PLOT	MULCHING (kg)
PLOT 1	ZERO
PLOT 2	4
PLOT 3	6
PLOT 4	9



Figure 6.3: Mulched plots

6.3 Soil Composition

Soil particles have spaces between them and these spaces are called pores. In dry soil, these pores are filled with air and after irrigation or rainfall the pores get filled with water.

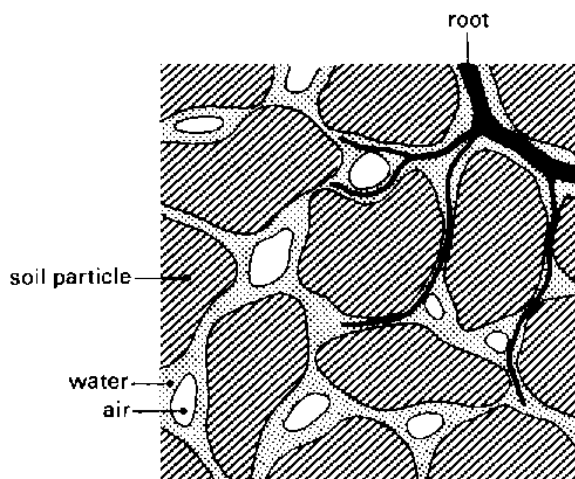

Figure 6.4: The composition of the soil

6.3.1 Soil Saturation

When soil pores are filled with water and no free water collects on the surface. The air earlier present in dry soil, is replaced by water in saturation soil. At saturation, because of absence of air in soil, crops cannot withstand for a period more than 2-5 days with rice crop as an exception.

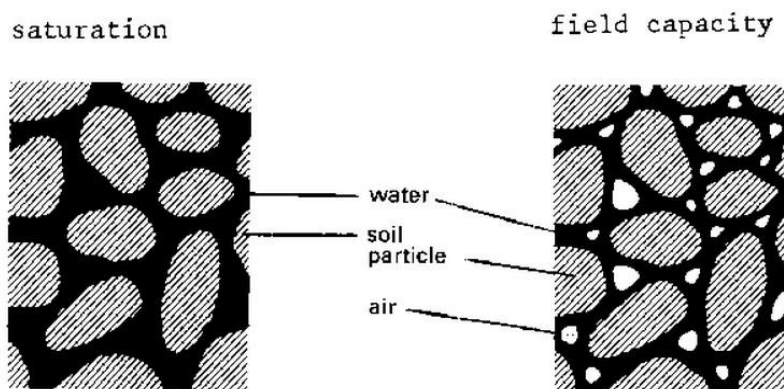

Figure 6.5: Soil moisture characteristics

With time, water present in large pores of soil moves downwards. Larger pores transfers water to smaller pores. Water drain from the large pores because of gravity and is held by small pores. This water drained from the large pores is replaced by air. The large soil pores get filled with both air and water, while small pore are remained filled within water. This stage is known as field capacity, the most suitable condition for crop growth.

6.3.2 Saturation Percentage

Saturation percentage is ratio of amount of water added to saturate dry soil to the total mass of dried soil. It is equal to the weight of water required to saturate the pore space divided by the weight of dry soil. Saturation percentage of different soil types in given in table 6.2.

Calculations

$$SP\% = \frac{\text{amount of water added}}{\text{mass of dried soil}} \times 100$$

Table 6.2 : Saturation percentage of different soil types

SP (%)	Soil Texture
0 < 20	sand or loamy sand
20 - 35	sandy loam
35 - 50	loam or silt loam
50 - 65	clay loam
65 - 135	clay
> 81	organic soils

6.4 Percent Moisture determination without Meter

6.4.1 Gravimetric method

It is direct method, involves drying soil sample in an oven to determine the amount of water in the soil. Percentage of water/ moisture in soil sample can be determined by oven-dry method. Test Procedure is:

1. Prepare a representative portion of the soil to be tested.
2. Determine the mass of the test sample and record this mass as the “wet mass”. The mass of the sample is determined before and after drying is to place it in a container. The mass of the container and sample are determined and the mass of the container subtracted.
3. Dry to soil sample at $110 \pm 5^{\circ}\text{C}$. The drying time will vary depending on the type, quantity, and condition of the sample. Remove the sample from the drying device and cool to room temperature.
4. Determine the mass of the test sample and record this weight as the “dry mass”.

Calibration

Determine the moisture content of the test sample as follows:

$$1. \text{ Mass of water in sample} = \text{wet mass} - \text{dry mass}$$

$$2. \text{ Percent moisture} = \frac{\text{mass of water}}{\text{dry mass}} \times 100$$

6.5 Methods of soil moisture measurement with meters

Oven-dry method is time consuming method to measure soil moisture. Methods of soil moisture measurements with meter are easy and fast. These methods are best for on-site moisture measurements.

6.5.1 Neutron scatter

Neutron method measures the amount of water in a volume of soil by measuring the amount of hydrogen in the soil. The probe of meter supplies fast moving neutrons. Hydrogen molecules in soil slow down the fast moving neutrons. As a result of the collision, a cloud of slow neutrons is formed.

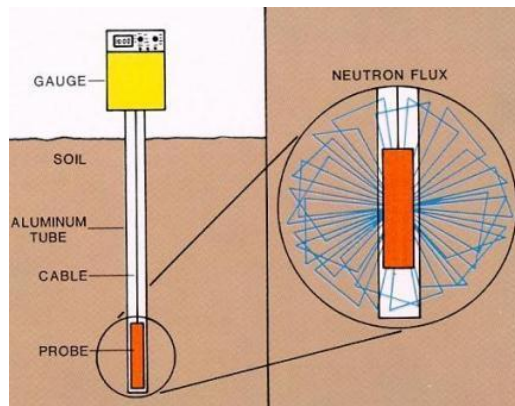

Figure 6.6: Neutron Method Of Soil Moisture Measurement

This could then be measured by the detector contained in the probe. The number of slow neutrons counted in a specific time is related to the total volumetric soil water content.

6.5.2 Di-electric Constant Methods

The di-electric constant method measures the high frequency transition capacity of soil when allowed to travel through it. The output values are related through calibration to moisture content present in soil. The working principle on this method is based on different di-electric values of water and soil. Soil has di-electric values about 2 to 5 and that of water is 80 when measured between 30 MHz and 1GHz.

Methods for measuring the di-electric constant of the soil water

1. Time domain reflectometry
2. Frequency domain reflectometry

1. Time Domain Reflectometry (TRD)

The time domain reflectometry device propagates high frequency electromagnetic waves through a cable which is connected to parallel conducting probes [34]. Signal is reflected from one probe to the other. The time between sending and receiving the reflected wave is then measured by meter. The propagation velocity can be computed by measuring the cable length and waveguide length. The larger the dielectric constant, the longer the time taken by pulse to propagate. The higher the dielectric constant, the higher soil moisture content in the soil. TDR units are expensive but highly accurate.

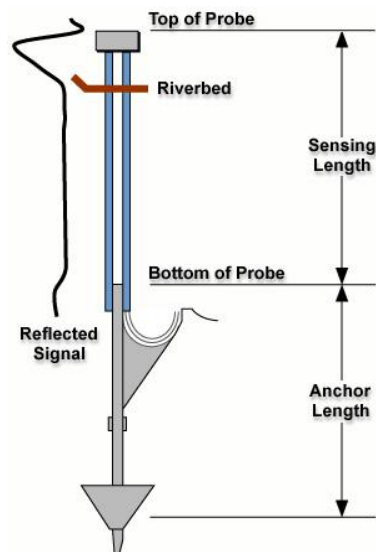

Figure 6.7: Time Domain Reflectometry (TRD) Probe

2. Frequency Domain Reflectometry (FDR)

Frequency Domain Reflectometry meter use radio wave frequencies to measure the soil moisture content. In FRD meter, soil complete the capacitive circuit by acting as dielectric. This capacitive circuit is part of feedback loop of high frequency transistor oscillator. Generally, frequency of about 150 MHz is used. The measure soil capacitance is related to dielectric constant and measured dielectric constant is then related to the volumetric content of water as in TRD method [35].

6.5.3 Tensiometer

Tensiometers measure soil water potential or tension. Tensiometer is a sealed, water-filled tube with a vacuum gauge on the upper end and a porous ceramic tip on the lower end. The tensiometer's hollow tube is filled with water and the porous tip is buried in the soil to the desired depth. Water is filled in the hallow tube of tensiometer, water in the tensiometer will come to equilibrium with water in the soil. Availability of water in the soil is indicated by readings. Readings are in centibars i.e. 1/100 of a bar. A reading of 100 is equal to 1 bar of tension. Tensiometers do not directly give readings, to obtain soil

water content, a moisture release curve i.e. water content versus soil tension is needed[36].

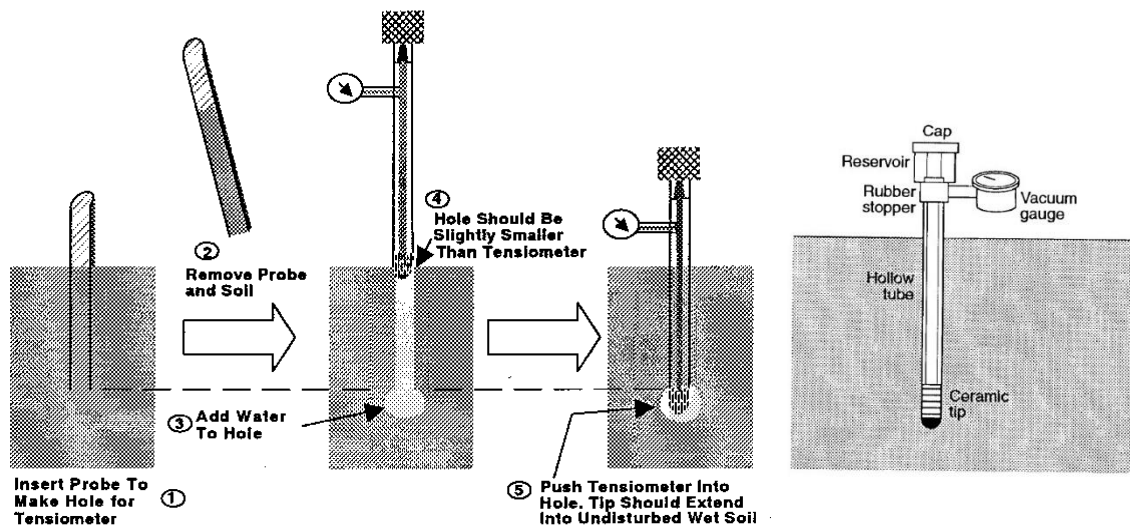

Figure 6.8: Tensiometer installation [36]

6.5.4 Electrical Resistance Blocks

Electrical resistivity can be used to measure a change in soil water content. In this method, resistance blocks with electrodes are buried in soil. The electrical resistance is measured between the two electrodes using meter attached to cable. Lower block water content, higher the resistance readings [37].

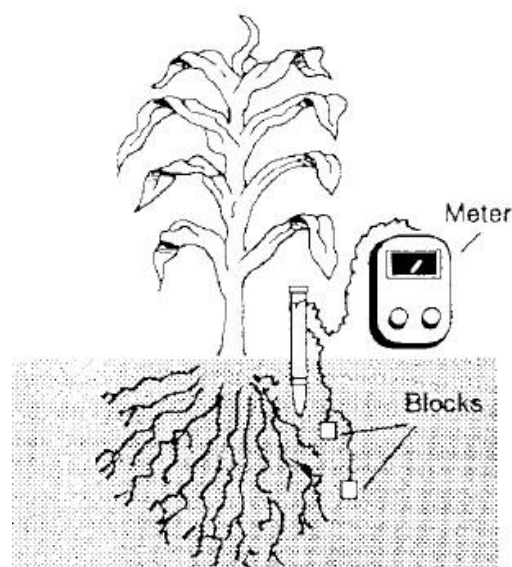

Figure 6.9: Electrical Resistance Blocks

6.6 Measuring Method Adopted

Mulching help soil to retain moisture by providing shading. Mulch protect soil by insulating it and prevent excess evaporation of water from soil exposed to sun. Mulched soils are cooler than non-mulched soils, reducing evaporation.

To measure the moisture of plots we used pre-calibrated soil moisture meter that works on the principle of change of resistance of soil between two points due to presence of water content in soil. Greater the amount of water content in soil, greater the conductance of soil, also less the resistance of soil. The readings were taken by dipping the probe in soil sample with proper contact between probe and soil.

Table 6.3: Meter's Specification

Meter's Specifications	
Range	0-100 saturation %
Accuracy	$\pm 0.2\%$
Operation	Battery 9v x 2
Electrode size	20 cm.
Display	L.C.D 3.5 digit



Figure 6.10: Soil Moisture Meter And Its Probe

6.7 Procedure of Taking Readings

While taking readings, caution was taken that contact between probe and soil should proper and tight. For best measurements of moisture percentage, readings were taken from 9 different points of each plot as shown in figure 6.11.

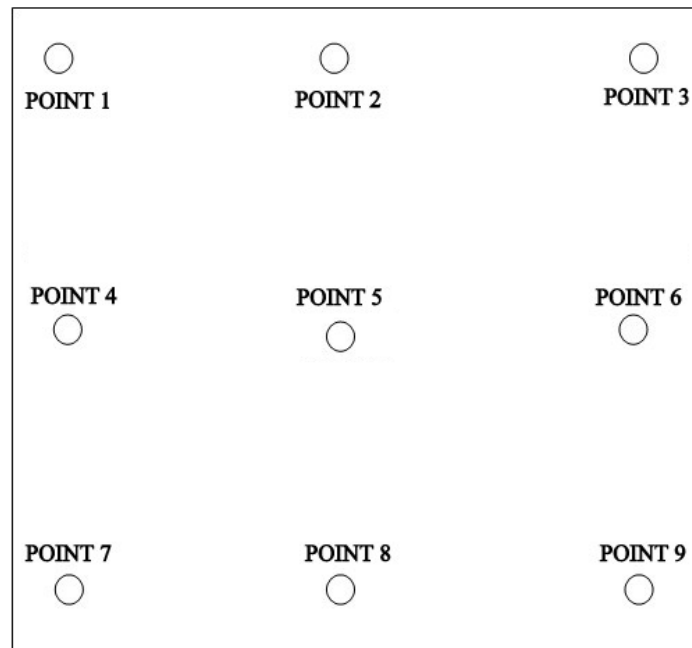

Figure 6.11: Procedure of Taking Reading

Chapter 7

Results and Discussion

7.1 Moisture Percentage Readings

During site preparation moisture of all plots was brought to 95% by adding required water and then plots were mulched with different amount of paddy straw. Further, readings were taken daily and data was maintained. For best measurements of moisture percentage, readings were taken from 9 different points of each plot.

Fortunately, we encountered a very practical situation, wherein after six days of natural evaporation, all the four plots received equal amount of rainfall. The moisture loss for these four plots mulched with different amount of straw, before and after the rainfall are shown in table 7.1 and table 7.2 respectively.

Table 7.1: Moisture readings of the plots with various mulching amounts before rain i.e. from 06/03/12 to 11/03/2012

	PLOT 1 (zero Kg) moisture %	PLOT 2 (4 Kg) moisture %	PLOT 3 (6 Kg) moisture %	PLOT 4 (9 Kg) moisture %
06-03-2012	95	95	95	95
07-03-2012	93	94	94	95
08-03-2012	91	92	93	94
09-03-2012	89	90	91	93
10-03-2012	87	89	90	91
11-03-2012	85	87	89	91

During this observation period, plot 1 was not mulched. Taking unmulched plot as the control and comparing it with other plots with different amount of mulch, the optimal paddy straw mulching amount was to be determined. Because of rain on 12-03-2012, moisture percentage of all the plots raised equally. Graph drawn for readings upto 11-03-2012, shows that plot 1 without mulching, loosed moisture rapidly as compared to other mulched plots. Moisture retention was more in plots with more mulch. Moisture percentage of plot2 with 6kg mulch was more than plot3 with 4kg mulch and plot4 had more moisture percentage than that of any other plot.

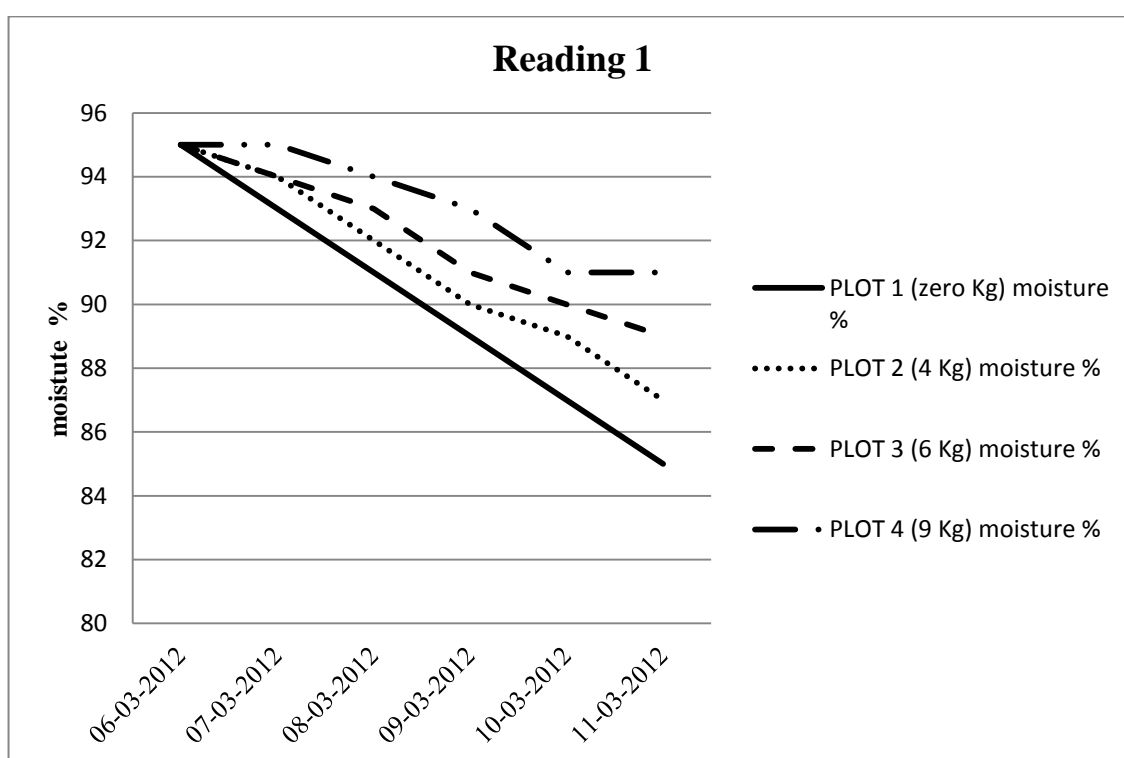

Figure 7.1: Readings from 06/03/12 to 11/03/2012

* rain on 12-03-2012 raise the moisture percentage

On 12-03-2012, rain raised the moisture percentage of all plots by equal moisture percentage i.e. by 5%. Moisture percentage raised to 90 % from 85% , 92% from 87%, 94% from 89% and 96% from 91% in case of plot1, plot2, plot3 and plot4 respectively. From 13-03-210 onwards readings were taken daily.

Table 7.2 : Moisture readings of the plots with various mulching amounts after rain i.e. from 12/03/12 to 04/04/2012

	PLOT 1 (zero Kg) moisture %	PLOT 2 (4 Kg) moisture %	PLOT 3 (6 Kg) moisture %	PLOT 4 (9 Kg) moisture %
12-03-2012	90	92	94	96
13-03-2012	88	90	93	95
14-03-2012	86	88	91	94
15-03-2012	84	86	90	92
16-03-2012	82	84	89	91
17-03-2012	80	82	87	90
18-03-2012	77	80	85	89
19-03-2012	75	78	84	88
20-03-2012	73	76	82	87
21-03-2012	71	74	80	86
22-03-2012	69	72	78	85
23-03-2012	67	70	76	84
24-03-2012	64	67	75	83
25-03-2012	62	65	73	82
26-03-2012	60	63	71	81
27-03-2012	57	61	69	80
28-03-2012	55	59	68	79
29-03-2012	52	56	66	78
30-03-2012	50	54	64	77

31-03-2012	47	52	62	76
01-04-2012	45	50	60	75
02-04-2012	43	48	58	74
04-04-2012	40	45	54	72

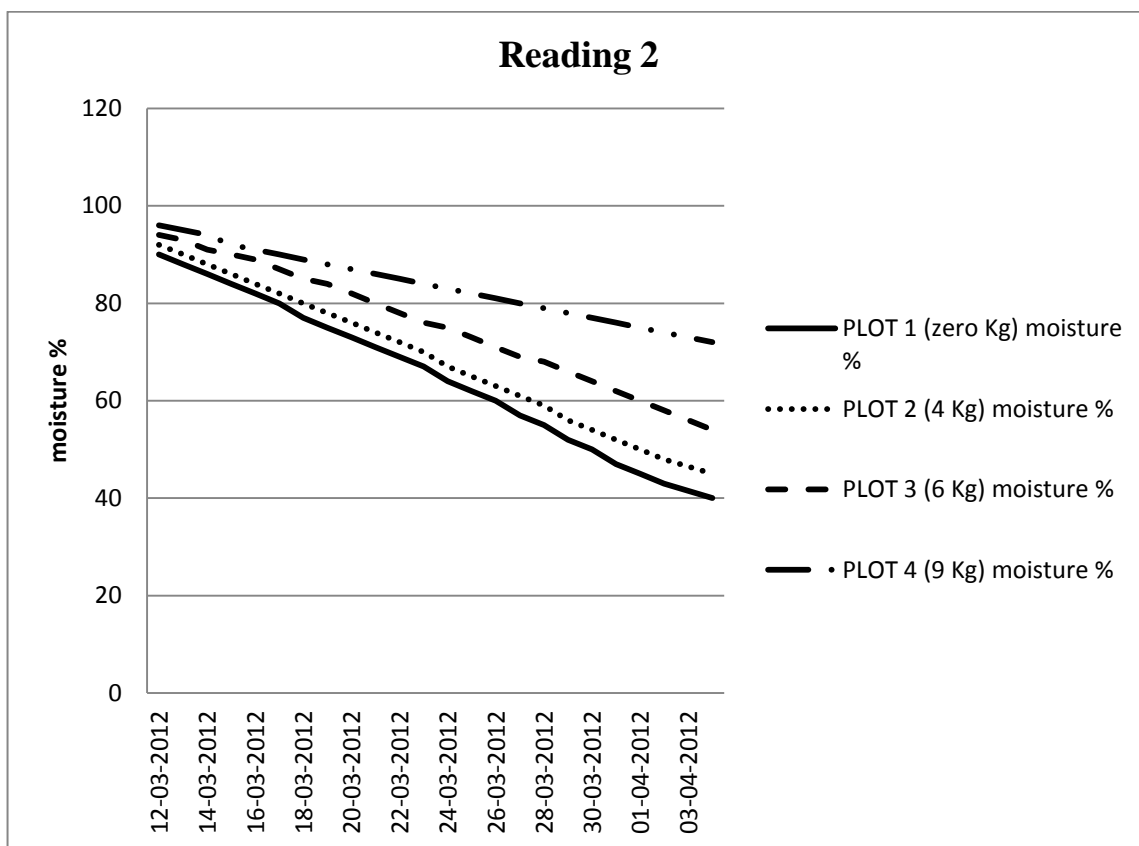

Figure 7.2: Readings from 12/03/12 to 04/04/2012

From Readings table 1 and table 2, it was clear that mulching of paddy straw helped the soil to retain moisture in large amount as compared to non-mulched soil. From the readings with 4kg, 6kg and 9kg mulch it was concluded that amount of moisture retention was proportional to amount for paddy straw mulch up to 9 kg of mulch in 10' x 12' plots.

7.2 Measuring Water Saving

After taking reading for one month i.e. 06-03-2012 to 04-03-2012, it was observed that mulching of paddy straw results in water saving by retaining moisture in soil for more time than non-mulched soil. The process of adding water was conducted very precisely. Each time small quantity of water was added and allowed to seep in. Then readings were taken, if required then more water was added and the same process was repeated again and again until moisture percentage raised to 95% in all plots.

At the end of this observation period, each plot was irrigated with different amount of water to bring the moisture level back to 95% and is shown in Table 7.3. Taking unmulched plot as the control, water savings per plot are shown in Table 7.4, while water saving per kg of straw used for different plots is given in Table 7.5.

Table 7.3: Water added to raise moisture percentage to 95 %

	PLOT 1(zero Kg)	PLOT 2(4 Kg)	PLOT 3(6 kg)	PLOT 4(9 kg)
	X4	X3	X2	X1
04-04-2012	205 litres	185 litres	150 litres	80 litres

Table 7.4: Water saving in each plot with unmulched plot as control

9 kg straw	water saving = (X4-X1)	125 Litres
6 Kg straw	water saving = (X4-X2)	55 Litres
4 Kg straw	water saving = (X4-X3)	20 Litres

Table 7.5: Water saving per Kg straw

9 kg straw	Per kg saving = $125/9$	13.89 Litres / Kg
6 Kg straw	Per kg saving = $55/6$	9.166 Litres / Kg
4 kg straw	Per kg saving = $20/4$	5 Litres / Kg

It was observed that by using 9kg mulch in plot, 13.89 litres of water could be saved per kilogram of mulch per irrigation. Till this part of study, optimal amount of mulch was 9kg in plot size 10' x 12'. From the measurements of water added to raised moisture percentage, we can calculate soil moisture sensitivity.

Table 7.6: Soil Moisture Sensitivity

LITRES	% MOISTURE	
80	23	0.2875
150	41	0.273333
185	50	0.27027
205	55	0.268293

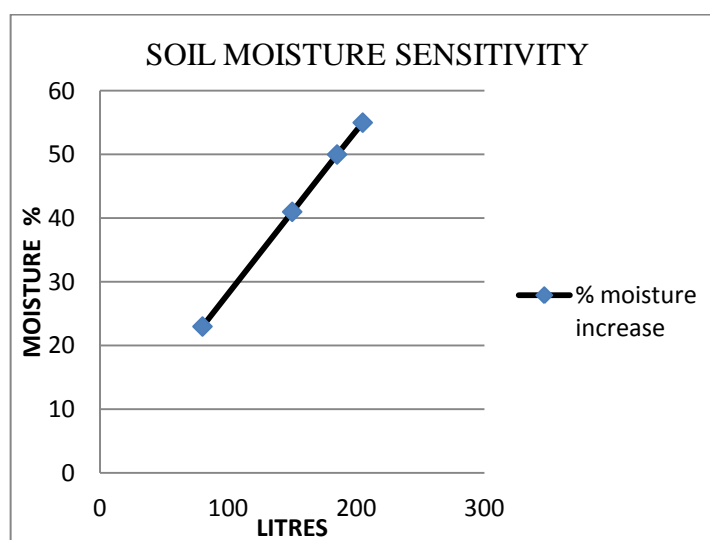
**Figure 7.3:** Soil Moisture Sensitivity

From the calculations, it was found that average value of soil sensitivity is 0.27% per litre. That means by adding one litre of water in plot of size 10 x 12', its moisture percentage could be increased by 0.27%. The practical average value that was observed during study was 0.25% per litre i.e. For 10' x 12' size plot, 4 litre of water increases moisture by 1%

It was evidenced from readings that the optimal moisture retention per kg of paddy straw used for mulching happens to be 9kg for the selected plot size. Another study in the subsequent month was made to extend the range of mulching with higher amounts.

7.3 Extending the range for optimisation

It was concluded that water saved is proportional to amount of mulching. To extend the range of mulching with higher amounts, we conducted second part of study. Plot 1 was kept un-mulched, plot2 was mulched with 9kg of paddy straw mulch, plot3 was mulched 1.5 times more than plot 2 i.e. with 13.5 Kg of paddy straw and plot 4 mulched with 1.5 times that of plot3 i.e. with 20 kg of paddy straw.

Table 7.7: Mulching amount of plots for extending the range for optimisation

PLOT	MULCHING (kg)
PLOT 1	ZERO
PLOT 2	9
PLOT 3	13.5
PLOT 4	20

Site was prepared again. Paddy straw length ranges from 80-120cm was in half the size to prepare it for mulching, fine threshing of paddy straw would increase the labour amount. To minimize labour cost, it was cut in half the size. Prepared paddy straw was weighted with weighing machine on the site. Paddy straw was spread properly of exact amount with hands. Moisture percentage of all the plots was then raised to 95% by adding required water. The process of adding water was conducted precisely.

Table 7.8 : Readings from 06/04/12 to 09/04/2012

	PLOT 1 (zero Kg) moisture %	PLOT 2 (9 Kg) moisture %	PLOT 3 (13.5 Kg) moisture %	PLOT 4 (20 Kg) moisture %
06-04-2012	95	95	95	95
07-04-2012	90	93	94	94
08-04-2012	86	91	93	93
09-04-2012	81	89	91	91

* Rain on 10th, 11th and 12th of April

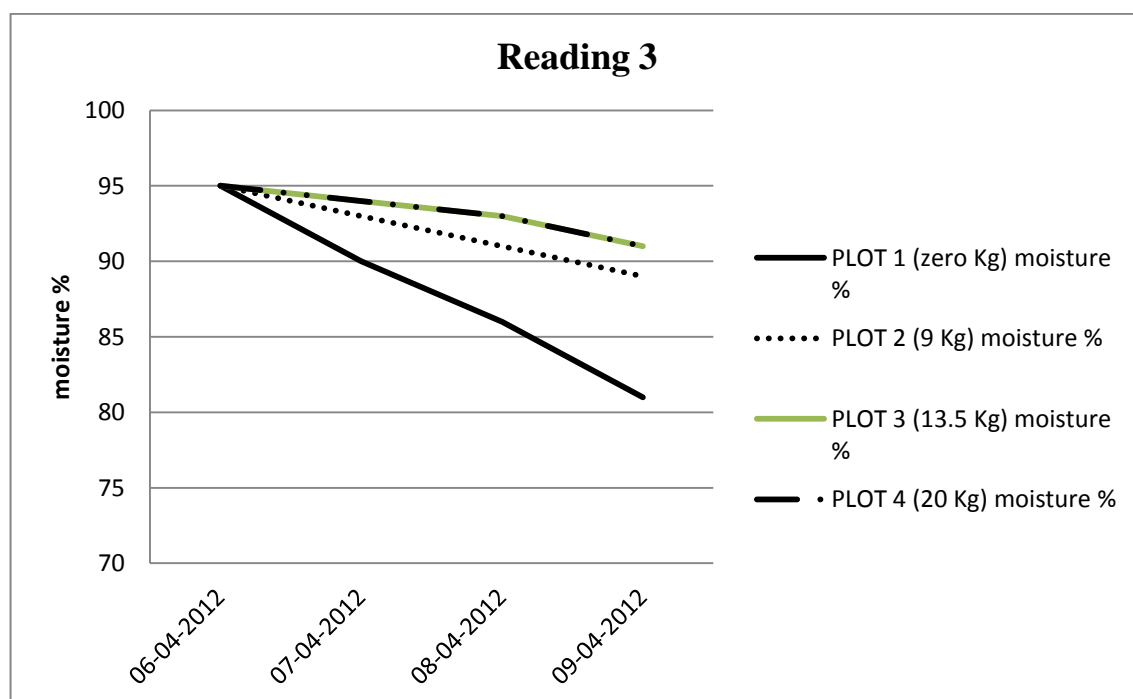
**Figure 7.4:** Readings from 06/04/12 to 09/04/2012

Readings shows that moisture percentage loss was 4 to 5 % per day in non-mulched plot in summer i.e. April, whereas it was 2-3 % per day in month of March. But the moisture retention in mulched plots remained approximately same.

Table 7.9: Readings from 13/04/12 to 29/04/2012

	PLOT 1 (zero Kg) moisture %	PLOT 2 (9 Kg) moisture %	PLOT 3 (13.5 Kg) moisture %	PLOT 4 (20 Kg) moisture %
13-04-2012	98	98	98	98
14-04-2012	94	96	97	97
15-04-2012	89	94	96	96
16-04-2012	85	92	95	95
17-04-2012	79	89	93	94
18-04-2012	74	88	92	93
19-04-2012	68	86	91	92
20-04-2012	63	84	91	91
21-04-2012	59	82	90	90
22-04-2012	54	80	89	89
23-04-2012	51	77	88	88
24-04-2012	46	75	86.5	87
25-04-2012	42	73	85	86
26-04-2012	39	71	84	85
27-04-2012	34	69	83	84
28-04-2012	29	66	82	83
29-04-2012	26	64	81	82

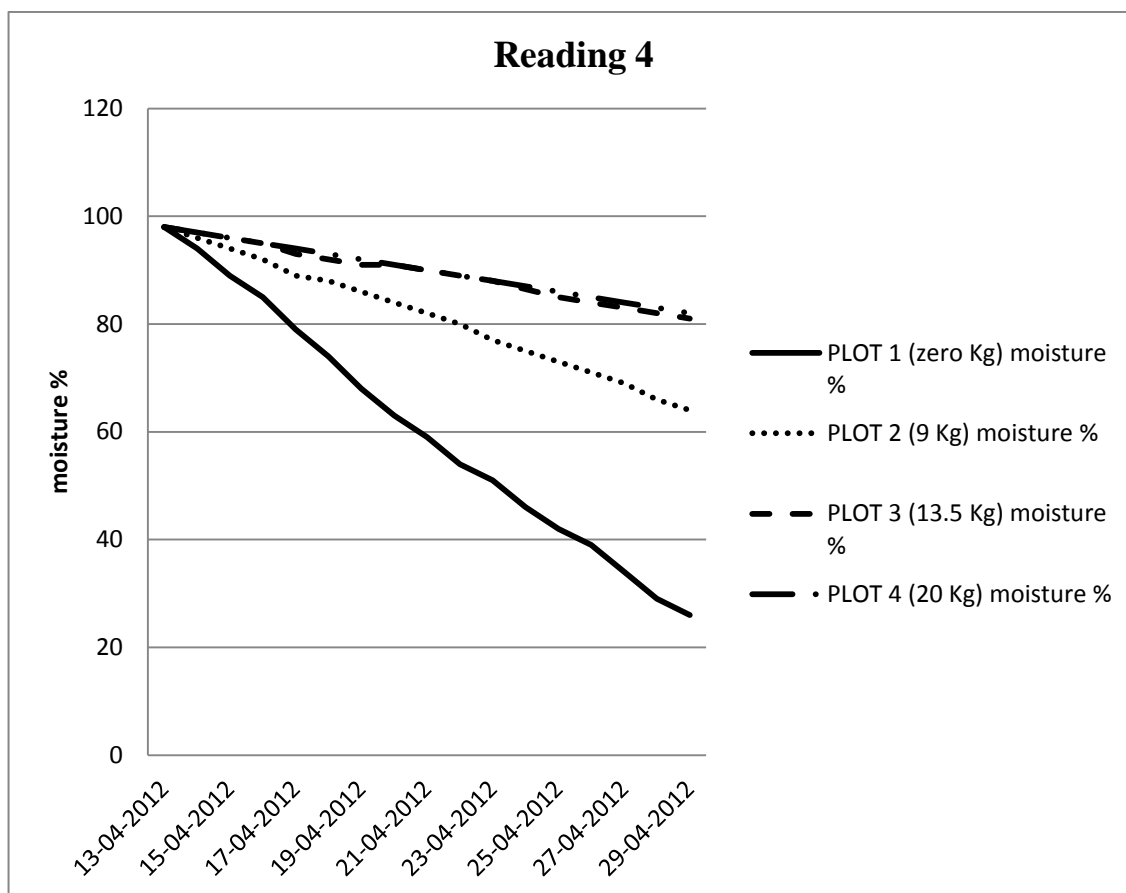

Figure 7.5: Readings from 13/04/12 to 29/04/2012

Due to continuous rains after 29-04-2012, we had to stop taking reading. In hot days , moisture percentage is much more in mulched plots as compared to un-mulched. From 13 April to 29 April, moisture percentage of plot1 i.e. un-mulched plot, dropped to 26 % from 98 %. in plot2 with 9kg mulch it drop to 62 %, in plot 3 with 13.5 kg mulch, it just drop to 81% and in plot4 with 20 kg mulch it dropped only to 82 %.

At the end of 2nd observation period i.e. the period for extending the range for optimisation, each plot was irrigated with different amount of water to bring the moisture level back to 95% and is shown in Table 7.10 . Taking unmulched plot as the control, water savings per plot are shown in Table 7.11, while water saving per kg of straw used for different plots is given in Table 7.12.

Table 7.10: Water added to raise moisture percentage to 95 %

PLOT 1(zero Kg)	PLOT 2(9 Kg)	PLOT 3(13.5 kg)	PLOT 4(20 kg)
X4	X3	X2	X1
255.5 litres	113 litres	52 litres	48 litres

Table 7.11: Water saving in each plot with unmulched plot as control

20 kg straw	water saving = (X4-X1)	207.5 Litres
13.5 Kg straw	water saving = (X4-X2)	203.5 Litres
9 Kg straw	water saving = (X4-X3)	142.5 Litres

Table 7.12: Water saving per Kg straw

20 kg straw	Per kg saving = 207.5/20	10.38 Litres / Kg
13.5 Kg straw	Per kg saving= 203.5/13.5	15.07 Litres / Kg
9 kg straw	Per kg saving= 142.5/9	15.83 Litres / Kg

Each plot size = 10' x 12' = 11.148 m² (1 foot = 0.3048 meters)

Optimal mulch for 11.15m² = 9 kg

Optimal mulch for 1 hectare i.e. 10,000m² = 8071 kg or say **8 tonne** (1)

Having explored the upper limits of mulching, it can now be concluded that the optimal result is obtain in case of 9 kg straw mulch on plot size of 10' x 12'. The higher value of moisture saving per kg straw in the second study in on account of higher evaporation loss in the month of April. This amount per hectare of field translates to 8071 kg or say 8 tonne per hectare. Incidentally the amount of paddy straw produced per hectare happens to be around 6 - 8 tonne [13].

7.4 Water Pumping Cost per Litre

To determine pumping cost, we took tube well tank measurements and note the time taken by the pump to fill it, which gave us pumping cost per litre.

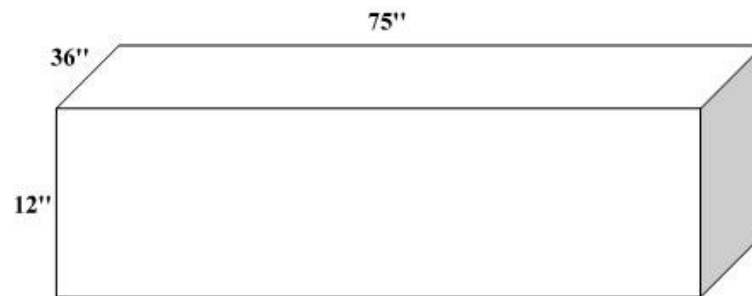

Figure 7.6 : Tube Well Tank Measurements

Volume of tube well= $12'' \times 75'' \times 36'' \times 2.5^3 \approx 5,00,000$ cc

$$\approx \mathbf{500 \text{ Litres}} \quad (2)$$

$$= \mathbf{0.5 \text{ kilolitre}}$$

Thus 1 Kilolitre is equal to Two Tanks

With the help of stop watch we noted the exact time that the submersible motor took to fill the tube- well completely. Time was observed by three watches, to get the accurate time.

Time taken by Submersible motor to pump 500 litres = **36 seconds** (3)

Submersible motor was of 12.5 Hp or we can say 9.185 kW

$$12.5 \text{ Hp} = 12.5 \times 735 = \mathbf{9185 \text{ watts}} \text{ or } \mathbf{9.185 \text{ kW}} \quad (4)$$

Units consumed in pumping 500 litre of water:

$$\text{Units consumed to pump 500 litres} = \frac{9.185 \times 36}{3600} = 0.0919 \text{ kWhr} \quad (5)$$

$$\text{Units consumed to pump 1 kilolitre} = 2 \times 0.0919 = 0.1838 \text{ kWhr} \quad (6)$$

Electricity is free to agriculture sector, but it cost to government. So we did our calculations on the bases of household electricity per unit cost.

$$1 \text{ unit} = \text{Rs } 5.5/-$$

$$\begin{aligned} \text{Cost to pump 1 kilo litre water} &= \text{unit consumed to pump 1 Kilolitres} \times \text{unit cost} \quad (7) \\ &= 0.1838 \times 5.5 \\ &= \mathbf{1.0109} \end{aligned}$$

So, 1 kilolitre costs Rs 1/- or 1 litre cost 0.1 paise

7.5 Saving of Electricity

Having explored the upper limits of mulching, it can now be concluded that the optimal result is obtain in case of 9 kg straw mulch on plot size of 10' x 12'. The annual saving of water can be determined by assuming one irrigation per month.

Table 7.12 : Water saving per kilogram straw

20 kg straw	Per kg saving	10.38 Litres /Kg
13.5 Kg straw	Per kg saving	15.07 Litres /Kg
9 kg straw	Per kg saving	15.83 Litres /Kg

The annual saving of water can be calculated as :

$$\begin{aligned} &= \text{water saving per month} \times 12 \\ &= 15.83 \times 12 = \mathbf{190 \text{ litres}} \quad (8) \end{aligned}$$

The annual saving of electricity can be calculated as :

$$\begin{aligned} &= \text{annual water saving} \times \text{water pumping cost} \\ &= 190 \times 0.1 = 19 \text{ paise per kg or say } \mathbf{20 \text{ paise per kg}} \quad (9) \end{aligned}$$

Commercial value of paddy straw is Rs 450 per tonne i.e. **45 paise per kg**.

Saving in terms of commercial cost :

$$= \frac{\text{cost of saved electricity per kg of agro-waste}}{\text{commercial cost per kg of agro-waste}}$$

$$= \frac{20}{45} \times 100 = 45\% \quad (10)$$

7.6 Recommendations

This pilot study done for the optimisation of mulching to converse irrigation water evaporation loss and hence the electricity used for pumping water has the following recommendations for the farmers:

1. Do not burn agricultural residue in open field
2. Do not sell this residue for power generation
3. Use this agro-waste in the same field, in the same amount as produced at the same time and avail the benefits of
 - a) Saving 45% of the commercial cost by way of water irrigation
 - b) Avoiding pollution caused by burning, either in the field or in the power generation plants
 - c) Avoiding loss of nutrients in the waste
 - d) Decreasing the fertiliser consumption
 - e) Increased yield
 - f) Retention of ever lowering ground water level

Chapter 8

Conclusion

This study determine the optimal amount of mulching to save the irrigation water. The study also compares the electricity produce by burning agrowaste, with electricity/water saved by mulching same amount of agrowaste fuel i.e. paddy straw in farms. The present study determines the optimal amount of paddy straw mulching required for the fields to prevent evaporation loss. This figure comes out to be 9 kg per 10' x 12' plot, that is 8 tonne of paddy mulch per hectare. It is rather surprising that the amount of paddy straw produced per hectare also lies in the same range[13]. This confirms our belief in practising natural farming, wherein the residue of any produce needs to be given back to the nature. On a philosophical note we may conclude that nature is indeed Divine! The options for the farmers to utilise the agro-waste are concluded in table 8.1

Table 8.1: Farmers Options

	BURN	SELL	MULCH
Earning/kg	0	45 paise	20 paise
Labour	nil	High	moderate
Soil fertility	decreases	Remains	increases
Pollution	high	Moderate	nil
Yield	decreases	Remains	increases
Fertiliser	increases	Remains	decreases
Recommend	avoid	May	must

Chapter 9

Future Scope

The present study determines the optimal amount of paddy straw mulching required for the fields to prevent evaporation loss. Mulching is an ecological approach to utilize the crop residue and agro-waste. Mulching helps to retain moisture in soil, to suppress weeds, to control temperature of soil, to act as a fertilizer and to increase yield in some crops. Further study can be conducted to determine the cost of labour for optimal amount of mulching i.e. 8 tonne per hectare determined by our study, effect of paddy straw mulching on soil fertility and crop yield.

References

- [1] Ministry of Power, India <http://www.powermin.nic.in>
- [2] Central Electricity Authority (CEA), <http://www.cea.nic.in/>
- [3] K.S.Sidhu, "Non-conventional energy resources" 2010, available at www.indiacore.com/kssidhu-non-conventional-energy-resources
- [4] Ministry of New and Renewable Energy (MNRE), India <http://www.mnre.gov.in>
- [5] "World Wind Energy Report 2010", Report: World Wind Energy Association February 2011
- [6] Indian Wind Energy Association (InWEA), <http://www.inwea.org/>
- [7] Singh Yadvinder; Singh Manpreet; Sidhu H.S.; Khanna P.K.; Kapoor S.; Jain A.K.; Singh A.K.; Sidhu G.K.; Singh Avtar; Chaudhary D.P. and Minhas, P.S. "Options for effective utilization of crop residues." Indian Journal of Air Pollution Control Vol. 8 No. 1, 2010, pp 61-67.
- [8] Agrawal S., Trivedi C. and Sengupta R. "Air Pollution Due to Burning of Residues." in Proceeding of the Workshop on Air Pollution Problems Due to Burning of Agricultural Residues, held at PAU, Ludhiana New Delhi, 2006
- [9] US EPA, "Carbon dioxide emissions from the generation of electric power in the US," report by the US department of Energy and US Environment Protection Authority, Washington DC, July 2000.
- [10] US EPA, "Emission Facts: Average Carbon Dioxide Emissions Resulting from Gasoline and Diesel Fuel." EPA420-F-05-001 February 2005
- [11] Zhang Hefeng; Xingnan Ye; Tiantao Cheng; Chen Jianmin; Yang Xin and Zhang Renyi, "A laboratory study of agricultural crop residue combustion in China: Emission factors and emission inventory" Atmospheric Environment 42,2008, pp: 8432–8441

- [12] Samra J.S.; Singh B, Kumar K, "Managing crop residues in the rice-wheat system of Indo-Gangetic plains. In Improving the Productivity and Sustainability of Rice-Wheat Systems: Issues and Impacts. Am. Soc. Agron. Special Pub. No. 65, 2003, p. 173-179.
- [13] Singh R.P.; Dhaliwal H.S.; Humphreys E.; Sidhu H.S.; Singh Manpreet; Singh Yadvinder and John Blackwell, "Economic assessment of the Happy Seeder for rice-wheat systems in Punjab, India" in AARES 52nd Annual conference, Canberra, ACT, Australia, 2008
- [14] Sharma PK. " Effect of crop residue management practices and green manuring on nutrient dynamics and soil productivity in rice-wheat cropping system., 1998, PhD thesis G.B. Pant University of Agriculture and technology, Pantnagar, India
- [15] Indian Renewable Energy Development Agency Limited (IREDA "Biomass power cogeneration" <http://www.ireda.gov.in/>
- [16] Punjab Energy Development Agency (PEDA). "Biomass power projects" <http://peda.gov.in/eng/Bio-mass%20Power.html>
- [17] Mann Margaret K.; Spath Pamela L., "Life cycle comparison of electricity from agriwaste and coal", Proceedings of 3rd ACEEE Summer Study on Energy Efficiency in Industry 'Industry and Innovation in the 21st century', Saratoga Springs, USA, 15-18, June 1999, pp.559-569.
- [18] Delivand Mitra Kami; Barz Mirko and Garivait Savitri, "Overall Analyses of Using Rice Straw Residues for Power Generation in Thailand- Project Feasibility and Environmental GHG Impacts Assessment" Journal of Sustainable Energy & Environment Special Issue, 2011, pp: 39-46
- [19]Jalkheri power plant, "Monitoring period: 01/10/2006 - 31/08/2007" available at <http://cdm.unfccc.int/Projects/DB/BVQI1152945720.4/iProcess/BVQI1191411273.06/view>

- [20] Lonia B., "Studies in techno economic aspects of power generation from agriwaste in India", PhD thesis, Thapar university Patiala, India , June 2005, pp. 49-53.
- [21] Mulumba L.N. and Lal R., "Mulching effects on selected soil physical properties." Soil Till. Res., vol. 98, no. 1, 2008. pp. 106-111.
- [22] Gill B.S. and Jalota S.K., "Evaporation from soil in relation to residue rate, mixing depth, soil texture and evaporativity" Soil Technol.8,1996. pp: 293-301.
- [23] Prihar S.S.; Jalota S.K. and Steiner J.L., "Residue management for reducing evaporation in relation to soil type and evaporativity."Soil Use Manag.12,1996. pp:150-157.
- [24] Castrillo C.; Fondevila M.; Alibes X. and Joy M., "Chemical treatments for upgrading lignocellulosic resources and strategies for their utilization in ruminant feeding." In: G.C. Galletti (Editor), Production and Utilization of Lignocellulosics. Elsevier Applied Sciences, London, 1991. pp: 339- 313.
- [25] Devasinghe K.P.; Premarathne1 and Sangakkara1 U.R., "Weed Management by Rice Straw Mulching in Direct Seeded Lowland Rice" Tropical Agricultural Research Vol. 22 (3),2011,pp: 263 - 272
- [26] Unger P.W. and McCalla, "Conservation tillage systems". Adv. Agron. T.M. 1980. pp:2-53.
- [27] Hay R.K.M., "Effect of tillage and direct drilling on soil temperature in winter" J. Soil Sci. 1977, pp:403-409.
- [28] Dao T.H., "Tillage and winter wheat residues management effects on soil water infiltration and storage."Soil Sci.Soc.Am.J.57, 1993.pp:1586-1595
- [29] Mahajan Gulshan; Sharda Rakesh; Kumar Ashwani and Singh K.G.' "Effect of plastic mulch on economizing irrigation water and weed control in baby corn sown by different methods" African Journal of Agricultural Research Vol. 2(1), January 2007,pp. 019-026.

- [30] Wright S.F.; Starr J.L. and Paltineanu I.C., "Change in aggregate stability and concentration of glomalin during tillage management transition." *Soil Sci. Soc. Am. J.* 63, 1999. pp: 1825–1829
- [31] Dobermann A. and Fairhurst T.H., "Rice straw management" *Better Crops International* Vol. 16, Special Supplement, May 2002, pp 7-11.
- [32] Diaz-Perez J.C.; Phatak S.C.; Ruberson J.; Silvoy J.; and Morse R., "Utilization of mulches increase yield and improve weed control in no-till organic broccoli" In the annual Georgia Conserv. Prod. Syst. Trng. Conf., Tifton, Georgia, July 29-31, 2008.
- [33] Gupta Prabhat K.; Sahai Shivraj; Singh Nahar; Dixit C.K.; Singh D.P.; Singh Khem; Koul S.; Sharma C.; Garg S.C. and Mitra A.P., "GHG Emissions from Biomass Burning: Field Burning of Agricultural Crop Residue, in *Climate Change and India Uncertainty Reduction in Greenhouse Gas Inventory Estimates*". University Press, India, Chapter12, 2000, pp. 258-279.
- [34] Time Domain Reflectometry (TRD), Wikipedia, the Free Encyclopaedia Available at http://en.wikipedia.org/wiki/Time-domain_reflectometry
- [35] Prichard Terry L., " Soil moisture measurement technology", Water management specialist, University of California Davis. available at: cecentralsierra.ucanr.edu/files/96233.pdf
- [36] Evans Robert; Cassel D. K. and Sneed R. E., "Measuring soil water for irrigation scheduling: monitoring methods and devices" Published by: North Carolina Cooperative Extension Service, Publication Number: AG 452-2, Last Electronic Revision: June 1996.
- [37] Fischbach, Paul E., "G77-340 Scheduling Irrigation by Electrical Resistance Blocks", Historical Materials from University of Nebraska-Lincoln Extension, 1977 Paper 1686. <http://digitalcommons.unl.edu/extensionhist/1686>

List of Publications

PAPERS ACCEPTED

- [1] Singh Mandeep and Singh Jagmohan, " Agro-waste based power generation: A review", International Journal of electronics engineering, Volume 4, Number 2, 2012 (In Press)
- [2] Singh Mandeep and Singh Jagmohan, " Mulching with agro-waste: An alternate to agro-waste based power generation", International Journal of electronics engineering, Volume 4, Number 2, 2012 (In Press)
- [3] Singh Mandeep and Singh Jagmohan, " Optimising mulching vis-a-vis moisture retention in soil", International Journal of electronics engineering, Volume 4, Number 2, 2012 (In Press)