

DESIGN AND SIMULATION OF KLYSTRON TUBE AND Q-FACTOR IMPROVEMENT USING CAVITY PERTURBATION

A Thesis Submitted in Fulfillment of the Requirement for the Award of the Degree of

MASTER OF ENGINEERING

in Electronics and Communication Engineering

Submitted By

SEHAR BHUSHAN

801561027

Under Supervision of

Dr. Rana Pratap Yadav

Assistant Professor



ELECTRONICS AND COMMUNICATION ENGINEERING DEPARTMENT

THAPAR UNIVERSITY, PATIALA, PUNJAB

JULY, 2017

DECLARATION

I, Sehar Bhushan hereby declare that the work presented in this thesis entitled "Design and simulation of klystron tube and Q-factor improvement using cavity perturbation" in partial fulfillment of the requirement for the award of degree of Master of Engineering submitted at Electronics and communication department, Thapar University, Patiala is an authentic record of work carried out under supervision of Dr. Rana Pratap Yadav (Assistant Professor, ECED, Thapar University) from January 2017 to July 2017. The matter presented in this has not been submitted either in part or full to any other university or institute for the award of any other degree.

Date: 11th August, 2017

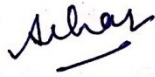
(Sehar Bhushan)
(801561027)

It is certified that the above statement made by the candidate is correct to the best of my knowledge and belief.

Date: 11th August, 2017

(Dr. Rana Pratap Yadav)
(Assistant Professor)

ACKNOWLEDGEMENT

First of all, I would like to express my gratitude to Dr. Rana Pratap Yadav, Assistant Professor, Electronics & Communication Engineering Department, Thapar University, Patiala for his patient guidance and support throughout the thesis. I am truly very fortunate to have the opportunity to work with him. I found this guidance to be extremely valuable. I am also thankful to Dr. Alpana Aggarwal, Professor and Head of Department as well as PG coordinator Dr. Hem Dutt Joshi, Assistant Professor, Electronics and Communication Engineering Department, their help made the work smoother.

Then I would like to thank entire faculty and staff of Electronics and Communication Engineering Department and the friends who devoted their valuable time and helped me in all possible ways towards successful completion of this work. I thank all those who have contributed directly or indirectly to this work.

I thank The Almighty - The supreme and the only supernatural power for imparting me courage, confidence to attain a full stop for this project.

Lastly, I would like to thank my parents for their years of unyielding love and encouragement, they have always wanted the best for me and I admire their determination and sacrifice.

Sehar Bhushan

ABSTRACT

The advent of vacuum tubes, klystron being one of its kind is regarded as a revolution in the field of communication. The most efficient use of such tubes is in transmitters and receivers as amplifiers, along with this various other vacuum tubes found its application in different scientific and commercial fields as well as in devices such as cathode ray tube. The various other fields in which these tube amplifiers find its usage is spectroscopy and imaging devices, remote sensing, space research and high-data-rate wireless communication etc. It has been deduced that efficiency is the most important parameter. Hence constant efforts are being made to increase the Q-factor i.e. quality of the tubes by any means which is one of the ways to make its working more efficient. In the work been done the design and simulation of 2.7 GHz klystron has been discussed. The cavity of klystron is designed and simulated using CST Studio Suite software. The Q-factor of the cavity is initially found to be 12695 which is not up to the desired value. In further trail, Q-factor of the cavity is improved using Cavity perturbation method. Here a structural change based on the analysis, called perturbation is incorporated in cavity design. The adopted perturbation significantly enhanced the Q-factor up to 13304 without having any significant effect in operating frequency klystron. It is the discussion of only one method i.e. through cavity perturbation to improve the quality of the vacuum tube (klystron) whereas there are many others ways as well one being electro-polishing or coating with materials like titanium etc.

TABLE OF CONTENTS

Sr. No	Name of the Chapters	Page No
	<i>Declaration</i>	<i>ii</i>
	<i>Acknowledgement</i>	<i>iii</i>
	<i>Abstract</i>	<i>iv</i>
	<i>Table of content</i>	<i>v</i>
	<i>List of tables</i>	<i>vii</i>
	<i>List of figures</i>	<i>viii</i>
<i>Chapter 1</i>	Introduction.....	<i>1</i>
	1.1 Preamble.....	<i>1</i>
	1.2 Development.....	<i>3</i>
	1.2.1 Spark, arc and alternator.....	<i>4</i>
	1.2.2 Vacuum Tubes.....	<i>5</i>
	1.2.3 Discrete Transistors.....	<i>6</i>
	1.2.4 Custom/Integrated Transistors.....	<i>7</i>
	1.3 High power RF amplifier using tubes.....	<i>8</i>
	1.4 Vacuum Tube types.....	<i>10</i>
	1.4.1 Magnetrons.....	<i>11</i>
	1.4.2 Special space-charge control tubes.....	<i>11</i>
	1.4.2.1 Triode tubes.....	<i>11</i>
	1.4.3 Klystron.....	<i>12</i>
	1.4.3.1 Application.....	<i>16</i>
	1.5 Klystron designing.....	<i>16</i>
<i>Chapter 2</i>	Literature Survey.....	<i>19</i>
<i>Chapter 3</i>	Identified research gaps and objective.....	<i>24</i>
	3.1 Problems encountered.....	<i>24</i>
	3.2 Objective.....	<i>24</i>
<i>Chapter 4</i>	Cavity design and simulation.....	<i>26</i>
	4.1 Methodology.....	<i>26</i>
	4.2 Cavity design.....	<i>28</i>
	4.3 Klystron cavity.....	<i>30</i>
	4.4 Deformed klystron cavity.....	<i>32</i>
<i>Chapter 5</i>	Results and Discussion.....	<i>37</i>

5.1	Results.....	37
<i>Chapter 6</i>	Conclusion and Future scope.....	45
6.1	Conclusion.....	45
6.2	Future scope.....	45
	References.....	47
	<i>List of Publications</i>	49

LISTS OF TABLES

Sr. No	Table Details	Page No
<i>Table 4.1</i>	Cavity parameters for the frequency of 2.7 GHz.....	31
<i>Table 4.2</i>	Parameters for cavity of the frequency of 2.7 GHz after cavity perturbation.....	33
<i>Table 5.1</i>	Comparison of results of klystron cavity and after cavity perturbation..	44

LISTS OF FIGURES

Sr. No	Figure Details	Page No
<i>Figure 1.1</i>	<i>Different amplification techniques.....</i>	4
<i>Figure 1.2</i>	<i>An early model of De Forest's audion</i>	6
<i>Figure 1.3</i>	<i>Classification of Tubes.....</i>	8
<i>Figure 1.4</i>	<i>Classification of vacuum tubes.....</i>	10
<i>Figure 1.5</i>	<i>Schematic symbol of triode.....</i>	12
<i>Figure 1.6</i>	<i>Basic two cavity klystron.....</i>	14
<i>Figure 1.7</i>	<i>Designing the re-entrant klystron cavity.....</i>	15
<i>Figure 4.1</i>	<i>Flow chart of the whole process to take place.....</i>	26
<i>Figure 4.2</i>	<i>Flow chart of the process to improve Q-factor of the cavity.....</i>	27
<i>Figure 4.3</i>	<i>Geometry of rectangular klystron cavity and drift tube designed.....</i>	28
<i>Figure 4.4</i>	<i>Depicting various dimensions of re-entrant cavity.....</i>	28
<i>Figure 4.5</i>	<i>Rectangular klystron tube simulated.....</i>	30
<i>Figure 4.6</i>	<i>Cavity designed according to the dimensions.....</i>	32
<i>Figure 4.7</i>	<i>Designed cavity with introduction of small cylindrical foreign object..</i>	33
<i>Figure 4.8</i>	<i>Electric field pattern at port 1.....</i>	35
<i>Figure 4.9</i>	<i>Magnetic field pattern at port 1.....</i>	36
<i>Figure 5.1</i>	<i>Designed klystron cavity in CST.....</i>	37
<i>Figure 5.2</i>	<i>Excitation signal.....</i>	38
<i>Figure 5.3</i>	<i>The predefined magnetic field.....</i>	39
<i>Figure 5.4</i>	<i>Output amplified signal at the waveguide ports.....</i>	39
<i>Figure 5.5</i>	<i>Mesh control view.....</i>	40
<i>Figure 5.6</i>	<i>The particle view of klystron in PIC simulation.....</i>	41
<i>Figure 5.7</i>	<i>The designed cavity.....</i>	41
<i>Figure 5.8</i>	<i>S-parameter graph of the cavity showing 2.7GHz as the output frequency.....</i>	42
<i>Figure 5.9</i>	<i>Designed cavity with introduction of small cylindrical foreign object.....</i>	43
<i>Figure 5.10</i>	<i>Output frequency of the deformed cavity through S-parameter graph which is approximately 2.7 GHz.....</i>	43

CHAPTER 1

INTRODUCTION

1.1 PREAMBLE

An amplifier is one of the most important and common elements in communication systems in military, satellite, high power antennas for transmission and reception etc. The requirement for the amplification are as varied as the systems where they are used. Amplifiers are available in large number of form factors ranging from miniscule ICs to the largest high power transmitter amplifiers [1] all depending on their area of requirement.

For many applications in everyday life Radio Frequency(RF) amplifiers are used. Some of the applications are, wafer processing in the chip manufacturing unit, magnetic resonance imaging i.e. MRI and importantly cellular phones i.e. a source of commercial communication. Hence for proper functionality of these devices we need to design, check and enhance the performance of the RF amplifiers properly. Several components are needed to be taken care of while designing RF amplifiers because of its use in many critical fields like military and communication.

RF amplifiers can be constructed in a successful manner depending on the transitions that take place between various stages of it. There are various topologies of RF amplifiers which are given as A, B, C, D, E, AB, S and F class. Resonators as well as matching devices make an important constituent of RF amplifiers because they are responsible for the stability of the device. By changing the components involved in a resonator like resistors and capacitors, the properties of resonator can be changed and can then be used for amplifiers of different frequencies. Moreover there are many voltage, current and power sensing devices, which are basically used in the amplifier for control and stability. The various types of RF amplifiers are as given below depending on the different frequencies of operation [2]-

- GaAs RF amplifiers[2] -GaAs power amplifiers can be used up to 5W of power, it can be enhanced using push pull or amplifiers up to 20-40 W.
- GaN RF amplifiers[2] -GaN power amplifiers have an output of approx. 10W whereas power density ranges from 5-12W/mm.
- CMOS RF amplifiers[2] -CMOS power amplifier is regarded as an efficient switched mode amplifier.

- High power RF amplifiers[2] -High power RF amplifiers are used where higher ranges of power is required such as high power antennas for communication systems etc.

Along with the type of system being required for a specific application, the parameters of an amplifier required also changes. The common parameters on which the amplifier's choice depends are-

- range of frequencies
- gain required
- output power
- linearity
- noise figure/power
- stability of system
- matching of impedance

Often there are design adjustments required to optimize or enhance any one parameter over the other. The compromises are usually necessary in performance for an amplifier that may be used in a general purpose testing application[1].

Now as stated above there are various methods to design the amplifiers according to the need i.e. the value of operational frequency, range of bandwidth, load that can be carried, power output, linearity, voltage requirement, efficiency of the amplifier, its cost and many more parameters to taken care of. These parameters define that where and what is the application of any of the amplifiers designed. Power amplifiers can be made up into transmitters in a wide variety of architectures, including envelope tracking and out-phasing. The main feature i.e. linearity of the amplifier can be improved through techniques such as feedback, feed forward, and pre-distortion again depending on the area of application.

A power oscillators circuit is used to convert input power which is in DC form to a momentous amount of output power which is RF, moreover some power supply circuitry is also attached before it i.e. to convert the general 230V AC power supply into DC so as to feed to the amplifier. In most cases a power amplifier is not merely a small-signal amplifier which is directed to saturation region. There exists a great variety of different power amplifiers, which not only employ simple amplification technique which is linear but much beyond that. The standard architecture of the amplifier utilise comparatively bigger power

amplifiers to convert a low-level signal into the high-level signal or output power as desired[3]. However, a large range of various architectures in actuality dismantle and then reorganise the signal to permit amplification with better efficiency and good linearity.

There is a high variation in modern applications. Frequencies like very low frequency(VLF) are used for communication, broadcasting and navigation. There is a lot of variation in output powers of unlicensed short-range wireless systems as compared to long-range transmitters used for broadcast. The range of variation of power is from 10mW to 1MW respectively. Different types of modulation techniques have been used for amplification depending on the type of application for which they are to be used. Power Amplifiers also find use in systems such as Radio detection and ranging(RADAR), Radio Frequency heating, in plasmas, in laser drivers, in process of magnetic-resonance imaging, many AC to DC and vice versa[3].

There is no single technique best suited for power amplification nor any single transmitter architecture is best for all applications. Many of the basic techniques that are now coming into use were devised decades ago but was not been able to used in circuitry or practically, it has only recently been made practical because of advances in RF-power devices and techniques used to develop these devices. Moreover it has been made possible because of the supporting circuitry such as digitalization in signal processing (DSP)[3].

1.2 DEVELOPMENT

The development of RF power amplifiers is dated back to the early 90's so till then many of the techniques of amplification as well has transmission has been changed. There was an advancement in the technology with the passing years, hence the ways changed and became efficient and easy to be processed and developed[4]. Basically RF power amplification can be divided into four main categories which are as shown in figure 1.1.

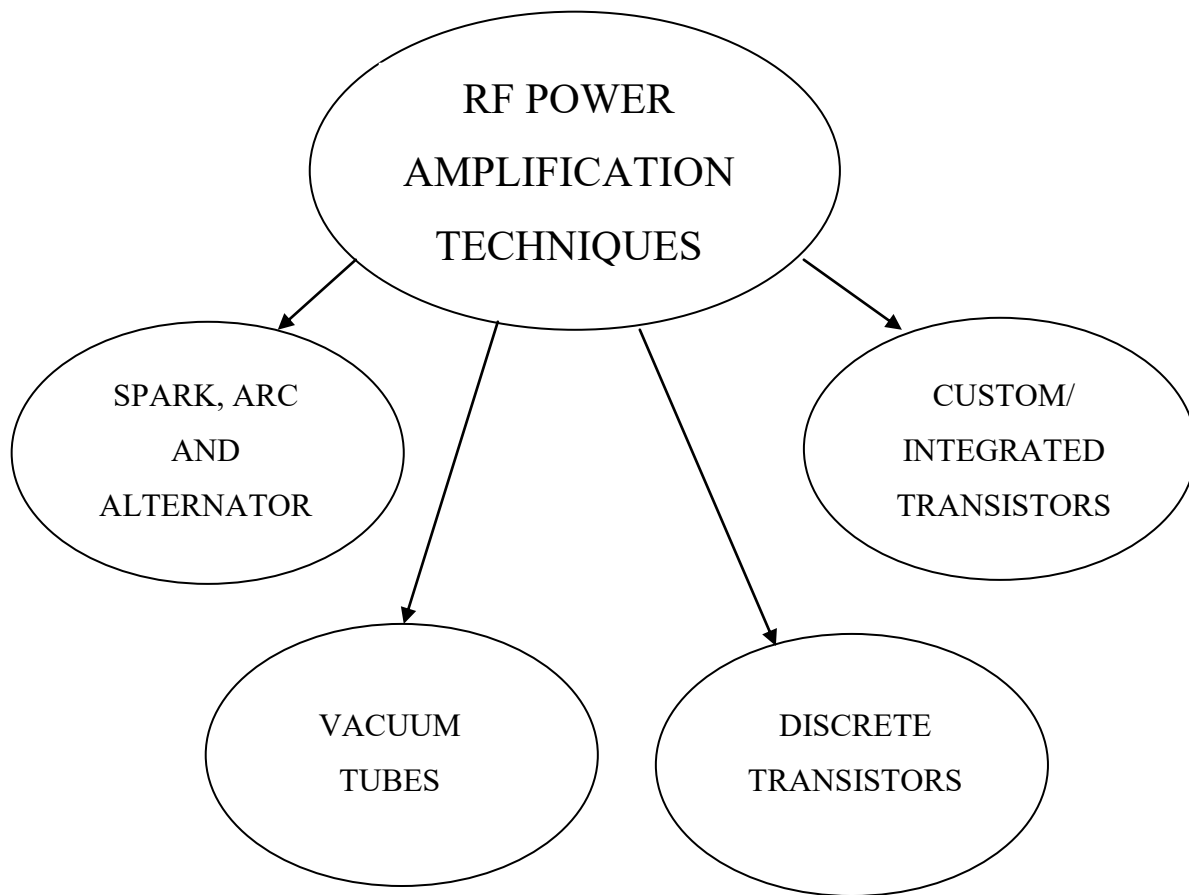

Figure 1.1 Different amplification techniques

1.2.1 Spark, arc and alternator

In the initial days of wireless communication i.e. from 1896 to the mid 1930s, the techniques which came in use for generation of Radio frequency(RF) power were spark, arc, and alternator techniques. The original RF-power device which by consideration was spark gap, charges a capacitor to a very high voltage that is usually from the mains AC supply. Then a discharge from the spark gap rings the capacitor which in turn tune the inductor as well as antenna, resulting in a damped sinusoid radiation. The Spark-gap transmitters were comparatively less expensive and capable of generating 600 W to 6 kW from a low frequency to a medium one [5].

The next one is the arc transmitter, it was extensively a contemporary of its previous technology i.e. the spark gap transmitter. Due to the negative-resistance characteristic

of the arc transmitter it can be operated as a continuous wave(CW) oscillator along with some fuzziness. In actuality the arc transmitter is firstly extinguished and then reignited one time per each Radio Frequency cycle. It is mitigated by a magnetic field as well as hydrogen ions that are generated from alcohol that is dribbled into the arc transmitter chamber. These arc transmitters were having the capacity to generate near about 1.5 MW at a low frequency. This power generated by arc transmitters is much higher than that generated by spark transmitters [6].

The third one i.e. the alternator is basically defined as an alternating current (AC) generator having an ample number of poles in it. Early RF alternators by Tesla and Fessenden, resembling its older technologies were capable of operation at a low frequency, but its updated version developed by Alexanderson protracted the operation of such techniques to medium frequency [7]. The frequency variation was restrained by regulating the rotation speed and up to 250 kW of output power could be generated by a single alternator. One such alternator transmitter (SAQ) remains viable at Grimeton, Sweden.

1.2.2 Vacuum tubes

It was with the advent of the De-Forest audion in 1907, that the thermionic vacuum tube offered a good means of generating and controlling RF signals electronically. It is shown in figure 1.2 below, RCA UV-204 (1920) was a kind of tube that allowed the pure continuous wave signals to transmit properly and expedited the transition to the higher frequencies of operation.

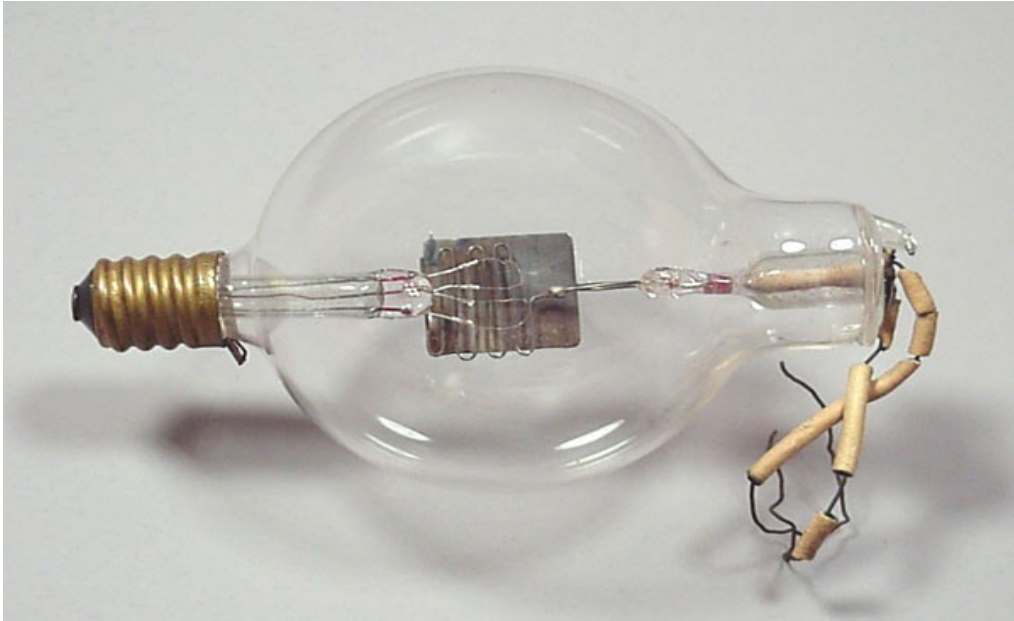

Figure 1.2 An early model of De Forest's audion[8].

The modern electronics concepts, like class A, B, AB and C power amplifiers along with many others, has its origination early in the era of vacuum tubes. In this era, the amplifiers including power amplifiers were characterized on the basis of their operation from high voltages to specified low voltages and by high-impedance loads to tuned networks for output. Whereas the basic circuitry of these amplifiers remained constant till the end of this era. However many people define vacuum tubes as a high voltage, glass encapsulated FET along with a heater[8].

Vacuum tube transmitters were dominating the amplification field from the 19th century i.e. 1930s up to the mid 1970s. They still remain in use and can be seen in some high power applications, where a relatively inexpensive as well as rugged mode of transmission is required for the means of generating 20 kW or more of Radio Frequency power[9].

1.2.3 Discrete transistors

At the end of the 1970s the advent of discrete solid state RF-power devices started with the introduction of silicon or germanium BJT's such as the 2N6093. Power

MOSFETs for High Frequencies and Very High Frequencies came into being in 1975 with the first one being VMP-4 by Siliconix. After this the GaAs MESFETs introduction in the late 1980s presented the various solid state power devices at comparatively lower microwave frequencies[3].

The solid-state RF power devices at lower voltages, have their own benefits, some of which are comparatively higher currents, and load resistances are relatively low so have been in use then. The high frequency and very high frequency power amplifiers were enabled through ferrite loaded transmission line transformers, to be functional for over more than two decades with respect to bandwidth. As the solid-state devices are sensitive to temperature, the circuits developed for linear power amplifiers were bias stabilization circuits. The implementation of a diversified range of feedback as well as control techniques was made achievable due to a large range of ICs and op-amps[3].

It was the in chip or encased form of solid-state power devices that was in market for commercial use. A number of small devices used to be encapsulated on a single chip. It was as high as 700 W power outputs that were available from a single encased push-pull device such as MRF157. The selection of the device by the designer basically depends on the factors like, which could provide the best results or fulfil maximum requirements. However only the semiconductor houses were interested in the developing process of the transistors and was not a great matter of concern to the circuit designer[3].

1.2.4 Custom/integrated transistors

A large variety of new solid state devices including High electron mobility transfer(HEMT), Heterojunction bipolar transistor(HBT) and Heterojunction field effect transistor etc were generated in late 1990s, using various different materials like indium phosphate(InP), Silicon carbide(SiC) and Gallium nitride(GaN) etc contributing amplification at higher range of frequencies i.e. upto 200 GHz and more. Whereas operation of many such devices depends on relatively low voltage levels, and many now-a-days applications rely on relatively low power. To improve the efficiency and linearity, the digital signal processing and microprocessor units are used jointly for feedback system and pre distortion techniques. Recent RF-power

devices are made available only on to-order basis and not otherwise. Basically, it all depends on the designer i.e. from specifying the size of the chip being designed up to the process that is to be used for the designing purpose.

1.3 HIGH POWER RF AMPLIFIER USING TUBES

The vacuum tubes are basically the part of electron tubes, which are being used for the amplification process. There are various types of vacuum tubes as well, with difference in the structures, its functioning is quite different and hence are used for different applications[11].

The hierarchy of the electron tubes is as shown in figure 1.3.

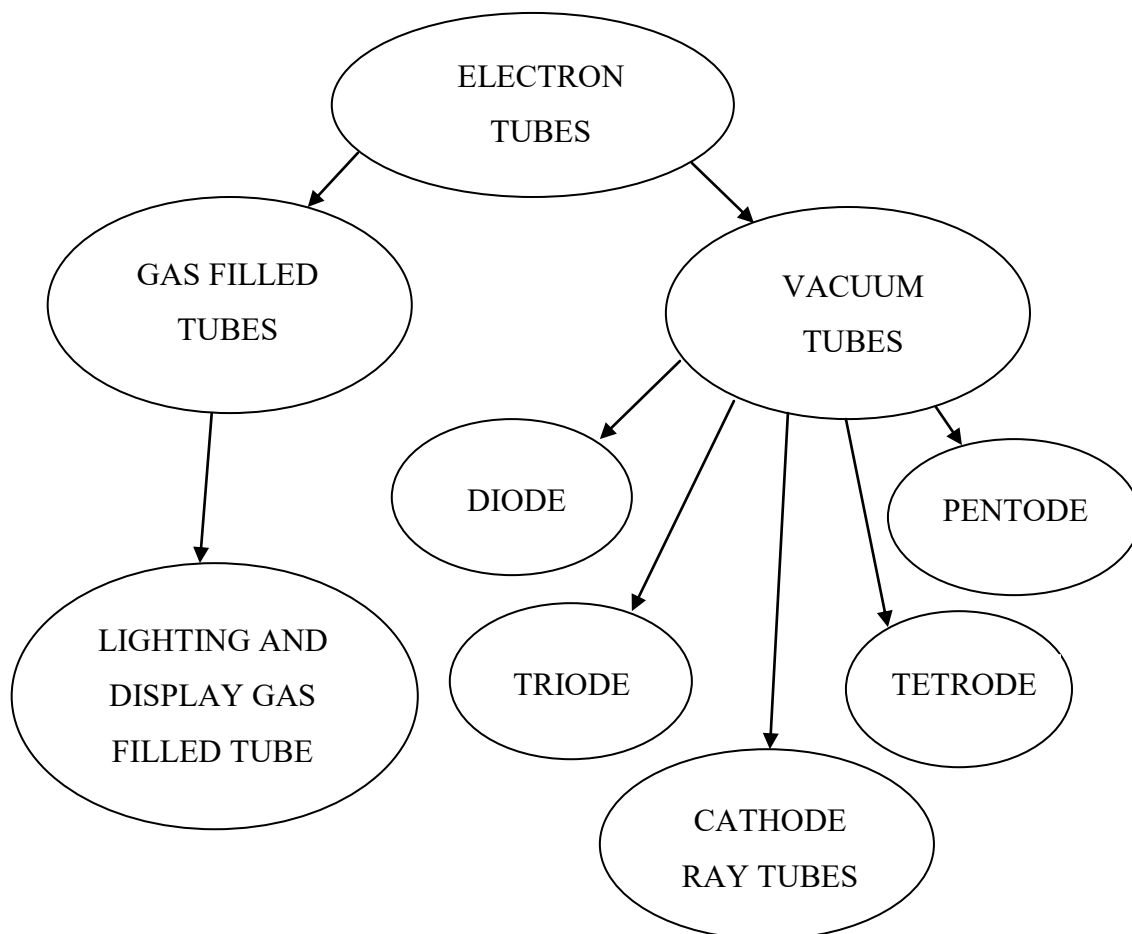

Figure 1.3 Classification of Tubes

According to the modern theory all matter is electrical in nature. All the three states of matter i.e. solid, liquid and gas is a potential source of electrons. A number of different processes serve to effect the release the electrons, those which are of importance to electron tubes being-

- THERMIONIC EMISSION- Electrons is forced to leave the surface of the material by providing it energy more than its work function, it is basically provided by heating the metal. Thermionic emission current density is given in equation 1.1-

$$J_T = A_0 T^2 e^{-b_0/T} \quad (1.1)$$

where A_0 is the constant for all metals and has the value of $120 \times 10^4 \text{ amp}/m^2K^2$ and b_0 is the constant that is characteristic of the metal.

- SECONDARY EMISSION- It is the phenomenon by which if some of the electrons which are getting emitted from the surface have such a high energy, that some of the internal electrons may get emitted due to them.
- PHOTOELECTRIC EMISSION- In this the energy required to release an electron from the metal surface may be supplied by illuminating the surface by light.

$$\lambda_c = \frac{ch}{eE_w} = \frac{12,400 A}{E_w} \quad (1.2)$$

This is the threshold wavelength given in equation 1.2, beyond which photoelectric emission does not take place.

- HIGH FIELD EMISSION- The presence of a very strong electric field will cause electron emission at the surface of the metal.
- IONIZATION- The process in which an atom loses an electron is called ionization. The atom that has lost the electron is called a positive ion.

With the release of electrons, a means for their control must be provided. Such control is affected by means of externally controlled electric and magnetic fields or both. These fields perform one or both of the following functions:

- Control the number of electrons that leave the region near the emitter.
- Control the paths of electrons after they leave the emitter.

Cathode ray tube is the most important example of a field deflected tube.[10]

1.4 VACUUM TUBE TYPES

The most famous out of the electron tubes were the vacuum tubes. They were available for a large variety of frequencies hence increasing the scope of its applications. There are three principal types of vacuum tube depending on different types of applications that have been useful in the past in the microwave region. The basic classification of tubes is shown in figure 1.4.

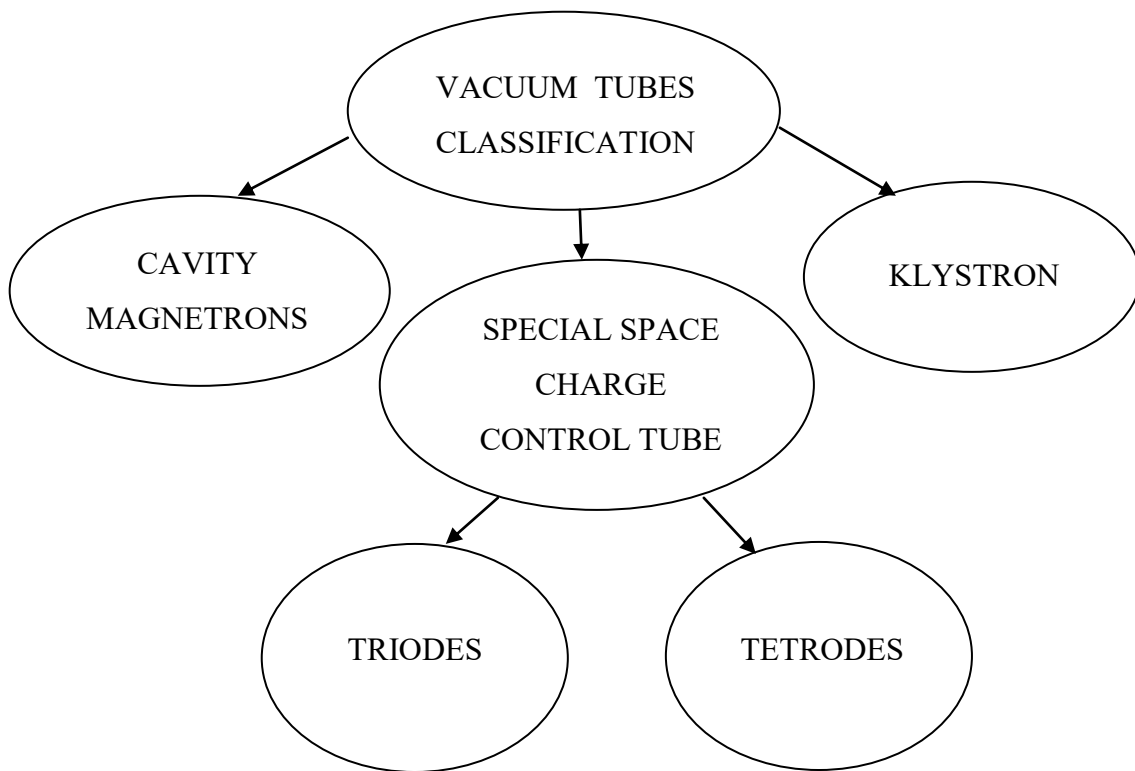

Figure 1.4 Classification of vacuum tubes

The various tubes shown in the block diagram is elaborated to get the basic idea about their working and field of application according to the working.

1. Cavity magnetrons
2. Specially designed space-charge control tubes -They are mostly triodes.
3. Klystrons-These are often called velocity-modulation tubes.

1.4.1 Magnetrons

Invention of magnetrons that came as the advanced version of klystron in terms of operating frequency and power generation was regarded as a great achievement in the field of RF and microwave. These magnetrons were basically used to deliver large amount of power in megawatts i.e. in the 3000 Me/sec region or the continuous output powers approaching a kilowatt[16]. One of its application due to excessive power deliverance it was used during the times of war.

1.4.2 Special Space-charge Control tubes

To overcome the problems experienced in space-charge control tubes, they were given the disk-seal triodes form so that they can work on high frequencies with greater efficiencies. As it got its shape which was responsible for its popular name i.e. lighthouse tubes, is a planar structure whereas for working at lower frequencies its cylindrical forms are being used. The whole of the space-charge control tubes are designed for infusion in the resonator with the electrodes leads being brought out through the disk seals via vacuum envelope. The cylindrical tubes are bit different in their constitution as there is an oxide coated cathode at each of the cylindrical mount along with an anode on the other side of the grid[16].

1.4.2.1 *Triode tubes*

Basically instead of anode and cathode in a diode, there is a third element in the triode which is called grid. This element called the control grid consisted of a wire mesh or a screen which surrounds the cathode and is situated close to it, as shown in the diagram given below in figure 1.5. Triode has many successors which are used in amplifiers, depending on the power and efficiency requirement of the equipment. The other tubes with small variations but larger efficiency and power output are tetrodes and pentodes which can be used in high power RF amplifiers.

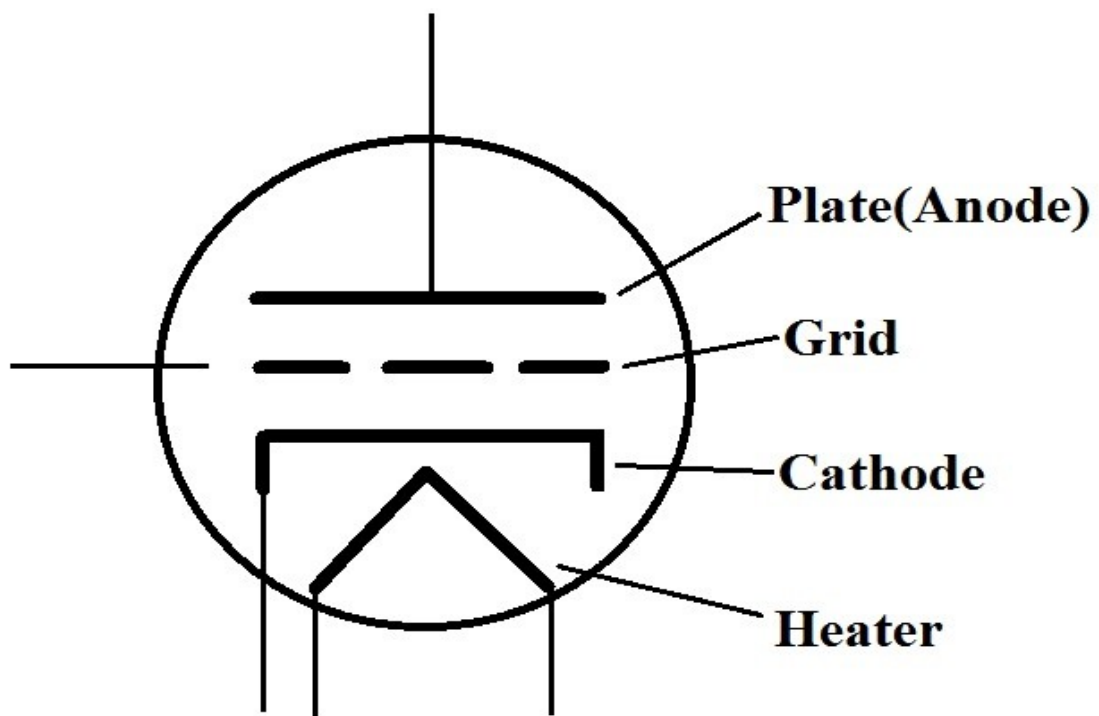

Figure 1.5 Schematic symbol of triode

The difference in tetrode and pentode from triode lies in the physical characteristics of both the tubes, they have more than one grid which makes a total of four and five electrodes respectively. The grid helps in better control and better output as compared to all others. The property of tubes being used in amplifier circuits is already stated above. These can be further used in the circuitry for transmission of signals for larger distances i.e. in communication systems, for any RF lab equipments testing and much more are its applications.

1.4.3 Klystron

Klystron tubes and lighthouse tubes stands in contradiction to one another. Both of them are logical transformations of a low frequency design rules to fulfil the microwave obligations. Both of them i.e. klystrons and the tubes are the result of the utilizing and minimizing, the long transit times of the process of amplification. The

two-resonator klystron amplifier is the simplest of all to discuss. A beam of electrons at very high velocity is accelerated from the gun which is known as electron gun then the beam passes through the communication gap of the input resonator known as the 'i buncher', where each electron either gets accelerated or decelerated from its initial velocity depending on the magnitude and the phase of the applied voltage during the movement of the electrons through the gap. Now the beam contains electrons of different velocities, due to this variation density modulation takes place while traversing in the tube called 'drift space'. The velocity of the electrons depends on the instant at which they cross the buncher cavity, accordingly the accelerated electron will reach out to the one that was retarded by starting out earlier, hence the bunching of electrons take place in such manner in the beam. These bunches of electrons formed in the drift tube is necessary for inducing current in the gap i.e. the tube and help generating the corresponding voltage across it. At this time the cavity is acting as the parallel resonant circuit and if the driving frequency is near to the resonant frequency, the voltage increases many folds than the modulation velocity[19].

Then the bunched beam passes through the interaction gap called the catcher of the output resonator, here due to the beam current's high frequency component, is helpful in driving the output resonator into oscillation. The coupling effect of this resonator helps it to act as a step-down transformer for power deliverance to the load. To re obtain the self-sustained oscillations the output power of the amplifier in a correct phase is delivered to the resonator as input. Then to describe the operation of such a process, some indirect process including three stages as given below are utilised instead of direct method of density modulation.

- The direct-current acceleration region
- The input gap of velocity modulation
- The drift space in which velocity modulation is converted to density modulation.

As in the triode, the same process of modulation is applied to the klystron as well, proving to be advantageous. In this the initial process of velocity modulation is enforced after the direct-current modulation than enforcing it before the direct current acceleration. Thus, although there must be somewhat less than one cycle transit time through either the cathode-grid region of the triode or the input gap of the klystron, in

the case of klystron the transit is made at high velocity. The basic klystron tube structure in which different parts of the cavity are depicted is shown in figure 1.7. The

capacitive coupling requires high value electrolytic capacitors and stored charge effects add signal delay.[12]

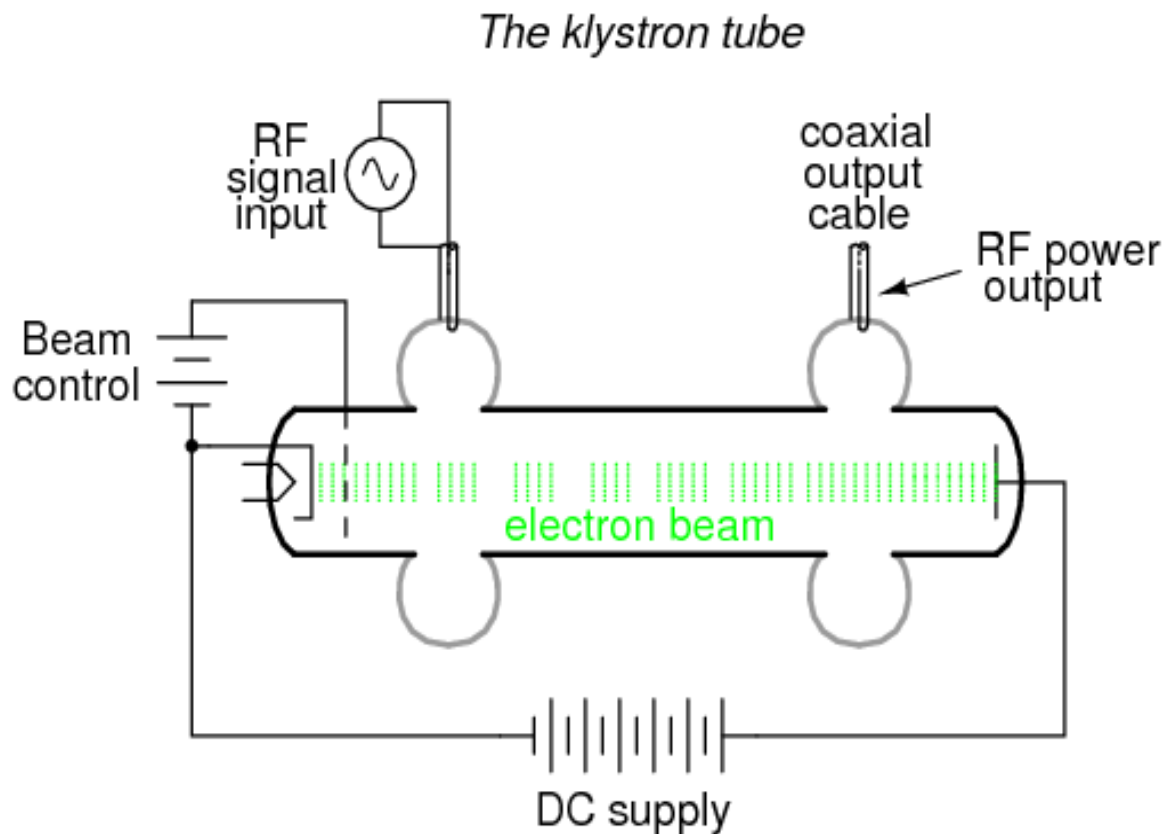

Figure 1.6 Basic two cavity klystron

The requirements on electrode spacing are therefore largely relaxed for the klystron, and the upper limit of the frequencies which is attainable is believed to increase by at least an order of magnitude. The main difference in this tube that differentiates it from the other forms mainly lies in the fact that a single resonator circuit serves as both buncher and catcher cavities. Instead of traversing a straight drift space the beam is turned back on itself by a retarding field, produced by a reflector electrode maintained at a potential negative with respect to the cathode. The reflected beam contains bunches, which result from the variation of transit time with velocity in a process formally similar to that occurring in the two-resonator klystron.

The simple reentrant klystron cavity designing can be shown in the figure 1.8. Here different parameters important for the designing are shown like R_{cav} depicts the radius of the cavity, R_{tub} depicts the radius of the tube whereas L_{cav} and L_{tub} depicts the length of the cavity and length of the tube respectively.

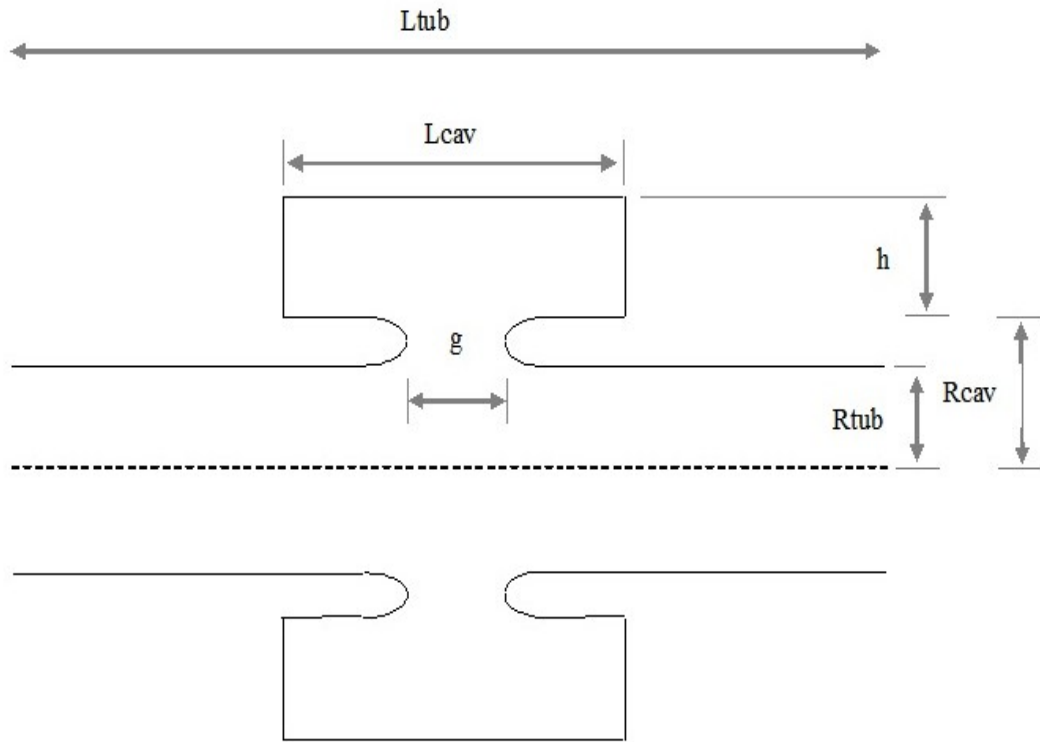

Figure 1.7 Designing the re-entrant klystron cavity [15]

The end result of the process of bunching in a retarding field differs by a phase factor of 180° from the field-free drift-space bunching mentioned in the discussion of the klystron amplifier. The faster electrons penetrate more deeply into the retarding field and therefore take longer to make a round trip; hence the electrons which made their first transit through the interaction gap early and were accelerated are overtaken by those which came later and were retarded. Oscillations may be produced in the reflex klystron provided the bunches in the beam return to the interaction gap at the proper phase to deliver energy to the resonator. This requirement can be met by adjustment of reflector voltage or spacing.

1.4.3.1 *Application*

By far the most common use of microwave triodes and reflex klystrons has been as local oscillators in microwave receivers. Other applications have been as signal generators or low-power transmitters. The microwave triodes lend themselves well to pulse operation; but klystrons are also useful, particularly where the duty ratio is high. Reflex klystrons are well adapted as frequency-modulated transmitters, especially where large frequency deviations are required.

Klystrons and microwave triodes can be used as super regenerative receivers, of course, but these receivers have not found wide application in the microwave region. The terahertz region of the electromagnetic wave spectrum, defined as the frequency interval between 0.1 THz and 10 THz or the wavelength between 3 mm and 30 mm, has been promising in the fulfilment of attaining the unique physical properties promising a wide variety of applications including the scientific and commercial ones. Spectroscopy and in the field of medical such as imaging of complex molecules or biological tissues, in the field of communication such as high data rate wireless communication, space field research, surveillance systems, remote sensing formulation etc are some of the applications that are included. However, in spite of remarkable progress in the Terahertz technology in the past decade, till now, the applications of microwave and radio frequency are strictly restrained to some special areas only such as communication, reason being low-cost, high-power along with no compact and room temperature Terahertz power source. These power sources can be considered equivalent to the ones which are well-established as well as commercialized in the neighbouring microwave and infrared bands. To change the situation, many scientific researchers have been dedicated in wide variety of research fields[14].

1.5 KLYSTRON DESIGNING

A klystron is basically an amplifier which uses the technique of velocity modulation for amplification. The basic structure of this amplifier consists of a RF section which is further comprised of re-entrant cavities and drift tube which is a hollow metallic pipe connecting the cavities together, an electron gun which provides the electron beam and at last a collector for

dumping of the spent beam. The amplification process takes place in the drift tube, where RF signal to be amplified and electron beam interacts with one another[13].

The operation of klystron using only two cavities is described in terms of bunching of electrons. The bunching of input signal and its velocity modulation takes place in the cavities. Electrons are categorized into fast electrons and slow electrons on the basis of velocity modulation. After modulation, the fast electrons meet the slow ones in the drift tube increasing the density and forming a single bunch having high current. All the parameters like gain, bandwidth and overall efficiency depends on the design of the RF section of the cavity. The Q-factor is the most important parameter which justifies the quality of performance of a klystron tube. Better the Q-factor at a specific frequency better is the performance of the cavity[13]. It is because Q-factor depends on total energy and power loss. Power loss and Q-factor are inversely proportional hence more the Q-factor less is the power loss. The most important requirement in cavity performance is minimum power loss, therefore the quality factor improvement in klystron is always a research concern and various literature has been found in same reference.

Initial methods for improving Q-factor were electro polishing to decrease the drop in Q-factor which was then observed in cavities at high electric field[20]. Next, titanium was used as a gettering material to improve the quality of the cavities[21]. Later the technique known as cavity perturbation was incorporated in cavities for better performance. Both the dielectric loss and dielectric constant were described using the method of resonance cavity perturbation[22]. In the next proposed method, electric field disturbances or images on the cavity walls around the inserted samples, which led to the decrease in dielectric constant, were considered[23],[24]. Moreover in later years, a paper was published showing the fact that an object with very small loss factor introduced to the cavity can increase the Q-factor of the cavity[25]. It was proved through measurements that installation of some samples made changes in the cavity with sample's intrinsic loss being calculated[26]. This is basically what cavity perturbation is.

As improved Q-factor means improved performance, so a number of methods were proposed for the same[27],[28],[29] and [30]. Some of the efforts that have been made are either by changing the cavity dimensions or by coating the cavity walls with different materials to change the permittivity and permeability of the cavity. These changes affect the initial electric and magnetic fields of the cavity and hence affecting the performance.

There are two klystron cavities being designed, one simple and other with Perturbation, of frequency 2.7 GHz are being designed and their performance in terms of frequency and Q-factor has been evaluated using CST STUDIO SUITE simulation software. The second cavity designed is modified with cavity perturbation, a technique in which a small foreign object is introduced in the cavity. In the perturbed cavity a small cylinder is introduced as a foreign object which enhances the Q-factor of the initial 2.7 GHz cavity.

CHAPTER 2

LITERATURE SURVEY

Frederick H. Raab *et al.* [3] Studied the transmitter and amplifier technologies of microwave and radio frequencies. Different types of amplifiers along with their historical developments and improvement in working based on parameters like linearity and efficiency are discussed. This advancement in the field of microwave and RF is not only required for communication but in many other fields as well like in equipments for imaging, jamming systems and RF heating devices etc. Hence each of the stated application requires its own set of well suited parameters which include bandwidth and linearity of the system designed, frequency and power depending on the specifications, impedance load, maximum efficiency and minimum cost.

M. Guarnieri [8] Published the detailed study about the early year devices which includes the invention of the vacuum tubes at the very beginning, moving on to the various advancements in the technologies that finally led to the establishment and development of the communication system. These devices are the base of the radio communications hence the study of its up gradation at various levels along with the inventors who were involved in the process of this advancement in technologies.

T. E. Yingst *et al.* [9] Described the previously made research and development in the field of high power gridded tubes along with the discussion of Low power tubes so as to lay the base for the high power tubes and are used in their driver stages. These new generation high power tubes with high gain, radio frequency and high efficiency which were backbone of broadcast industry have been developed. Some of them includes linear tetrodes, magnetically beamed triode tubes etc. the distribution amplifiers were developed along with the high power gridded tubes which was considered as a big achievement from circuit point of view. The life of these high power tubes were half compared to the theoretical tubes and lastly high power coaxitron was introduced in this category of tubes.

B. Levush *et al.* [11] reviewed the status and trends of vacuum electronics, with selected applications emphasizing recent advances in device performance in the microwave regime. The role of vacuum electronics in devices from ultra high frequencies to extremely high frequency range. In addition, exciting advances in vacuum electronics will provide dramatic

improvements in millimeter-wave regime including the multiple beam klystrons and gyro amplifiers as well as radar resolution, broadband very low-noise power at microwave frequencies range, compact high output power sources operating at comparatively lower voltages, and most importantly cost improvement.

Joe X. Qiu *et al.* [13] Described the advantages of using vacuum tube devices instead of solid state devices. These benefits included capability, efficiency and reliability as well as cost effectiveness. It showed why vacuum electronics is regarded as the most important technology in communication, military, commercial or any other field. It continues to lead the chart as they are being regarded as best solution for the high output power requirements when making decisions at the system level. The research in the field of vacuum electronics technology make it both new and old due to its legacy which is impressive, well known and keep on attracting the developers with each new advancement.

S.G. Jeon *et al.* [15] showed that a micro-fabricated reflex klystron can be a promising radiation source in the THz frequency region. Using 1 KeV, 20mA electron beam, over 100mW power transfer from the kinetic energy of the electron beam to the electromagnetic energy in the resonant cavity could be obtained. CST software was used along with the commercial MAGIC3D code to design and compare the results of the klystron cavity being designed. It is one of kinds of vacuum electronics devices which is used as an amplifier for high frequency applications.

Robson K. B. e Silva *et al.* [14] presented a sequence of steps to begin the project of a cylindrical re-entrant klystron cavity using analytical method and different CAD tools such as SUPERFISH and 3D Eigen mode solver i.e. CST software have been used for designing the cavity. The designed cavity works in Gigahertz range and is used in wide variety of applications. The two softwares used help to differentiate between the Q-factor of the cavity which is the basic parameter to define the performance efficiency. The klystron designed is one of kinds of vacuum electronics devices which is used as an amplifier for high frequency applications. Along with the Q-factor one more important parameter is taken care of and that is the Cavity R_{sh}/Q_0 . The last parameter whose account is kept is the frequency of the klystron re-entrant cavity being designed, the difference between the frequency coming out by using different software needs to be less deviated.

Gao D.P. et al. [17] studied the complex nonlinear beam–wave interaction in high-power klystrons, developing a 2.5-D code, based on a theoretical model combining particle-in-cell (PIC) method. In the model, the particle charge and the beam current are properly assigned onto the grids based on the PIC method; so that the space charge of the electron beam can be accurately calculated, and the port-approximation method is employed to simulate high frequency cavity fields.

Parakash A. et al. [23] Evaluated the relationship between various dielectric parameters which are responsible for any kind of change in the Q-factor and the resonant frequency of the cylindrical cavity being designed. The mode of the cavity is said to be TM_{010} i.e. transverse magnetic field. The different types of frequency derivations are made based on various lengths which are less as compared to the height of the designed cavity. Then in next section with a lot many assumptions the cavity is reduced to its simplified form in which the length of the cavity and its height are comparable. The results are hence generated with the same simplified form for different lengths.

Estin A. J. and Bussey H. E. [24] Performed measurements to find the quantities like complex permittivity and permeability of the isotropic media of the cylindrical cavity designed. It is done with high precision and all the working is at the microwave frequencies level. With an advancement to these measurements, to change the frequency via frequency pull through the resonator method a hole is introduced in the walls of the cavity. Along with the change in the frequency, this method also introduces error in the dielectric constant that has been measured. All these effects on the previous measurements are observed and calculated regarding it to be due to the perturbation of the cavity. Moreover correction factors to maintain the initially measured values are formulated.

Chen L. et al. [25] Discussed the change that occurs in the cavity when a dielectric sample is introduced basically reviewing the concept of cavity perturbation. It also examined that the cavity perturbation which is widely used for the measurement of dielectric permittivity may not be as valid for the dielectric samples with extremely low loss, whereas this type of dielectric when introduced to the resonant cavity may increase the Q-factor of the cavity. The Q-factor of the re entrant cavity with a sample of strictly no loss is introduced so as to find out how much this factor is dependent on the frequency. The formulas of resonant

perturbation were moulded by the use of quality factor being substituted before the perturbation for each of the corresponding frequency. This amendment proved to be of a great benefit as it was the reason for a drastic hike in the accuracy of the perturbation. This result was specifically of high importance for samples of low loss dielectric.

Miura T. *et al.* [26] Proposed a method through various experimental and theoretical observations to find the intrinsic loss of a sample that has been introduced in a cavity that has been designed which is not related to the Q-factor change due to the incorporation of the sample. It was concluded from the historical proves that the Q-factor does not get affected or changed due to the sample incorporation. The cavity perturbation is a method which was best suited to find out the permittivity of the designed re-entrant cavity. But with several experiments the proof of change in the Q-factor with the cavity perturbation have been found and discussed.

Petersen P. J. and Anlage S. M. [27] Measured the conductivity and magnetic properties of the sample that was introduced in the designed cavity leading to the measurements of cavity perturbation. For these methods to work efficiently, accurate knowledge of the resonant frequency as well as quality factor was must which also gets changed along with the introduction of any type of sample in the cavity. There were seven different methods that were formulated to get the accurate knowledge of the two parameters and compare and discuss what was concluded through the complex transmission data that was used. As a result the non-linear least-squares fit to the phase versus frequency and the non-linear least-squares fit to the Lorentzian curve were the most accurate ones for the SNR more than 65 and more noisy data respectively. It can be applied to many other different types of resonant phenomenon and hence regarded as a general conclusion.

Leong K. and Mazierska J. [28] Described that the accuracy of the method transmission-mode quality factor is better by 1% by the other methods used to find the unloaded quality factors for the microwave resonator. This 1% is given as an output for all the measurement ranges that have been practically known. The method of transmission-mode quality factor (TMQF) is used for coupling for a wide range of frequencies, moreover the measurable range of Q-factor is from 10^3 to 10^7 . There are many ways of determining the Q-factor but the most efficient was the one whose values were determined by the multi-frequency S-parameter data by Q-circle fits method. The ideal circular shape of the resonator's S-parameter gets distorted by being rotated and shifted from its original shape due to the

practicality of the measurement system thus resulting errors in the values of the quality factor. The equation derived by working in the transmission mode for the resonators and the method of fractional linear circle-fitting were the developed methods for Q-factor determination. From the two methods given the first one removes the effects of noise and all other non linearity's to get best suited measurements. Hence the TMQF method was used along with cables that were difficult to calibrate at the cryogenic measurements of thin films that were super conductors and had high temperatures and the dielectrics as well.

Coakley K. J. *et al.* [29] Estimated the re-entrant cavity's quality factor and resonant frequency on a frequency grid which is evenly spaced, the analysis being based on the resonance curve. The resonating curve being talked of is a scattering parameter's magnitude which is also complex in nature. Also in this curve parametrically the variance of the additive noise is characterised. The method used to find the Q-factor and resonant frequency of the via noise characterisation is known as WLS i.e. weighted least squares. This method has overpowered the other two methods which were called Estin and 3-dB methods, moreover the asymptotic theory 1- σ uncertainty estimation of the quality factor as well as the resonating frequency. The weighted least squares method is considered to be superior than others for calculating the two most important parameters, it gave the most accurate results especially for the measured under coupled resonances. The spacing that is optimal had to be decided to get the resonance curve sampled at equally spaced frequencies.

Miura T. *et al.* [30] Discussed the methods of improvement of quality factor. The one that was proposed was the RCA method i.e. resonance curve area method. This Q-factor improvement method tend to use cursor function that was established in a network analyser. The resonance curve area method's physical efficacy was also discussed and tested. This technique used along with the cavity perturbation method can be highly accurate. It was estimated that in terms of dielectric constant and loss tangent the method of resonance curve area is three times more conventional than the cavity perturbation method, whereas the cavity perturbation technique is also regarded as a rational one. Rest the various formulas generated for the various techniques are used to compare the accuracy of the different methods.

CHAPTER 3

IDENTIFIED RESEARCH GAPS AND OBJECTIVE

3.1 PROBLEMS ENCOUNTERED

- In Solid state devices there is less of stability than equivalent tubes, the device parameters change considerably with temperature as the various currents responsible for the overall behaviour of the device changes and hence these devices cannot withstand high temperatures. So cannot be used in designing high power RF amplifiers.
- The tubes were still a better choice except that with tubes there is more of distortion than the solid state devices ,these devices can withstand high temperatures but due to higher voltages in RF applications their parameters vary considerably, hence changing the output frequencies.
- Therefore tubes need to be managed with caution as they are being used mostly in the fields of higher voltages. In such applications more distortion leads to lesser efficiency and efficiency being the most important parameter along with frequency remaining same.
- Maintenance of tubes is more difficult, hence basically their efficiency is taken care of but they are better than their counterpart i.e. the transistors because they become unavailable after 20 years making their recovery or replacement difficult or impossible for a specific circuit for which it is required. There is no such problem in case of re-entrant cavities.
- Klystron tubes can still be used in many fields as an amplifier but with a greater efficiency.

3.2 OBJECTIVE

- As higher efficiencies are required in RF applications, so that the distortion does not affect the working of the device therefore methods are devised to increase the efficiency of the klystron cavity.
- Cavity perturbation being one of the methods to improve the efficiency through Q-factor calculation. Better the Q-factor better is the efficiency of the system designed

- as Q-factor is defined as the total energy by power loss. Hence more the energy and less the loss, more is the Q-factor and less is the distortion of the signal to be amplified.
- The main objective is to design a re-entrant cylindrical klystron first which is a microwave amplifier and works on the base of velocity modulation. After the designing cavity perturbation is incorporated to improve the working of the klystron tube being designed.
- There are many advantages of using tubes is that they are easy to maintain and the value of the parameters does not change with temperature, hence efficient tube designing is the foremost requirement.
- Amplification klystrons continue to find use in high-power, high-frequency radio transmitters and in scientific research applications.

CHAPTER 4

CAVITY DESIGN AND SIMULATION

4.1 METHODOLOGY

The basic objective is the designing of the klystron tube of a specific frequency by using specific values of the parameters required for designing. Then the next step would be to increase the efficiency or Q-factor of the designed cavity by using cavity perturbation. Firstly the following procedural steps are followed for the designing the amplifier i.e. klystron tube in figure 4.1.

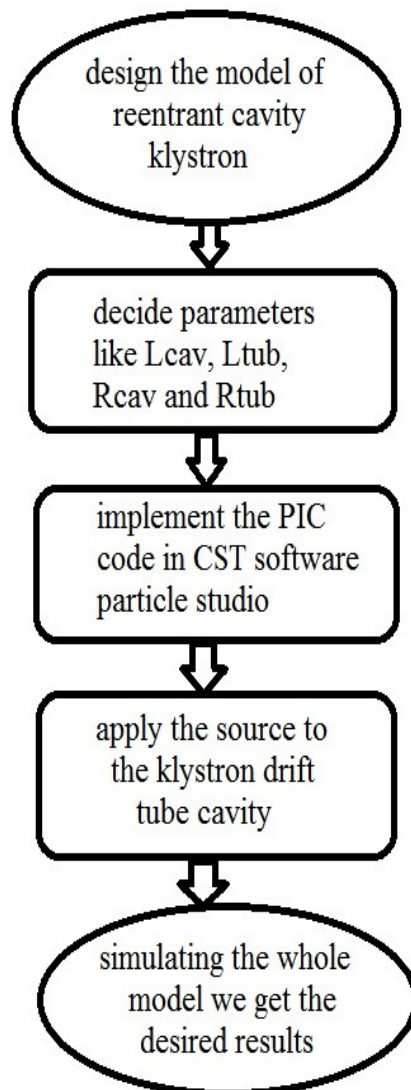

Figure 4.1 Flow chart of the whole process to take place.

The S-parameters and Q-factor is calculated through simulation thereafter. The whole process of improving Q-factor is depicted through a flow chart as shown in figure 4.2.

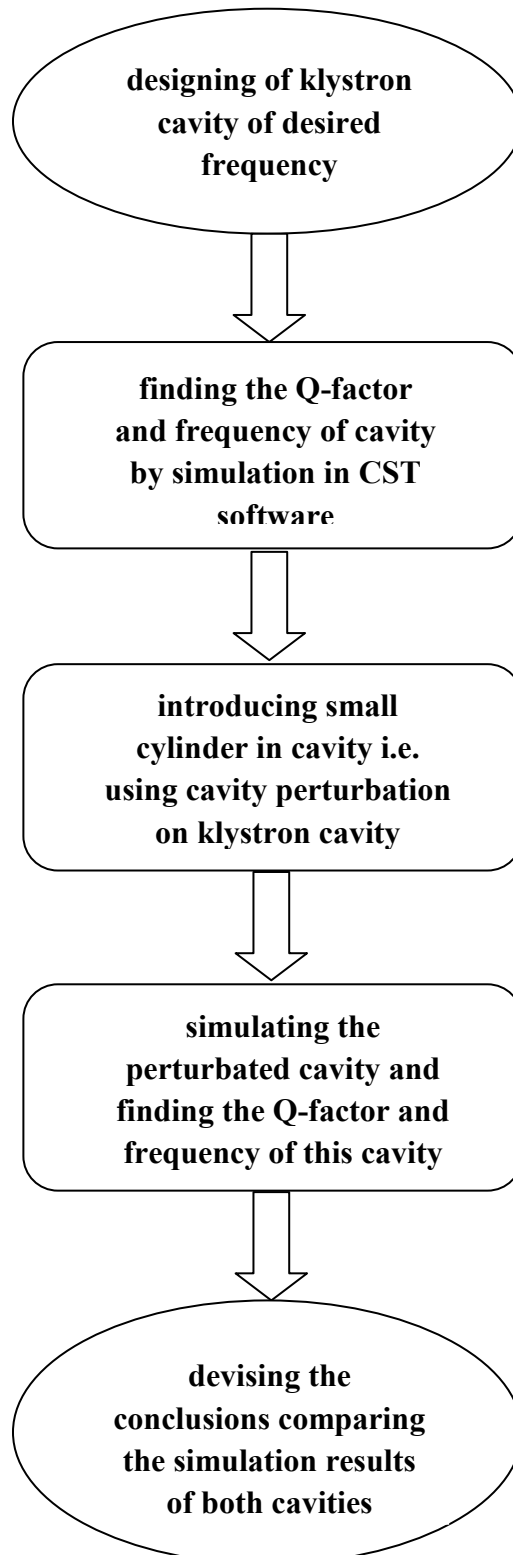

Figure 4.2 Flow chart of the process to improve Q-factor of the cavity

After the simulation of the desired frequency klystron tube, its cavity is being simulated with cavity perturbation to calculate the change in the Q-factor and estimate the amount of improvement in the Q-factor or efficiency of the designed tube.

4.2 CAVITY DESIGN

A cylindrical re-entrant cavity is used for designing the klystron tube. Its structure is shown in Figure 4.3.

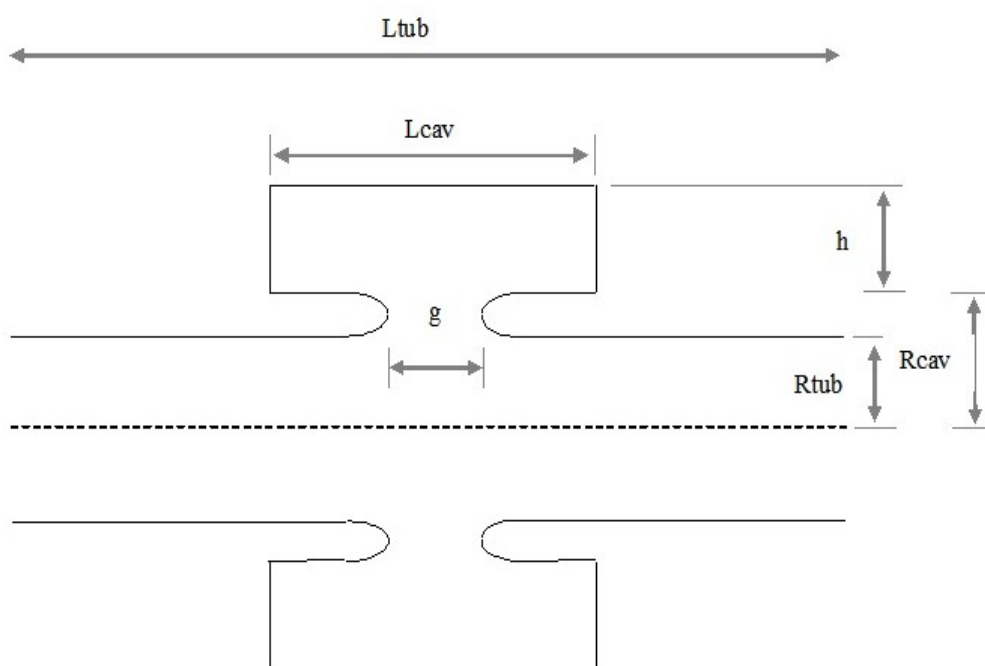

Figure 4.3 Geometry of rectangular klystron cavity and drift tube designed.

The various parameters used for designing the cavity are as given : length of the cavity is denoted by L_{cav} , length of the drift tube is denoted by L_{tub} , Radius of the drift tube and cavity is denoted by R_{tub} and R_{cav} , respectively. other than these h denotes the width of the waveguide and WW denotes its length.

The cavity of 2.7 GHz is designed using analytical formulae for the given frequency that is given by

$$f_r = \frac{c}{2\pi\sqrt{\varepsilon}} \left\{ al \left\{ \frac{a}{2d} - \frac{2}{l} \ln \frac{0.765}{\sqrt{l^2 + (b-a)^2}} \right\} \ln \frac{b}{a} \right\} \quad (4.1)$$

where f_r is the resonant frequency of the cavity, ε is the permittivity and a , b , d , l are the dimensions of the re-entrant cavity as shown in Figure 4.4.

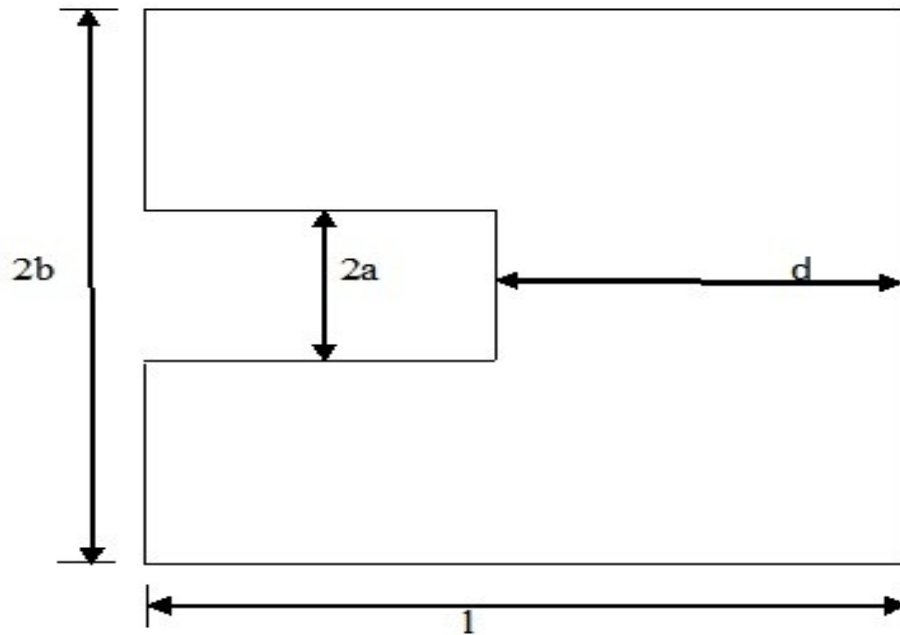

Figure 4.4 Depicting various dimensions of re-entrant cavity.

The results and conclusions of the cavity designed is all based on the simulation in CST MICROWAVE SUITE of the basic CST software. The output resonator is set up in such a way that the blue part in the figures depict the vacuum filled part and the red part depict the waveguide port. The power coupled in the waveguide is automatically recorded. The Gaussian bunches are being emitted from the emission surface. The outputs we get are generated under the influence of the constant magnetic field of 0.2 Wb/m^2 . The electric field is generated due to the moving electrons, which can be changed by changing the parameters of the cavity[18].

As the simulation of the designed cavities is being performed using the software, firstly the klystron tube of the same frequency as that of cavities is generated, then the two cavities are being formulated and explored thoroughly. First being a simple cavity of the klystron and second one being the outcome of cavity perturbation. The structure of the klystron tube simulated is shown in Figure 4.5.

4.3 KLYSTRON CAVITY

The basic klystron cavity is designed to be working at a desired frequency of 2.7GHz. A Gaussian signal is provided and within a constant magnetic field, electrons are being processed in the waveguide and the cavity to get the desired results.

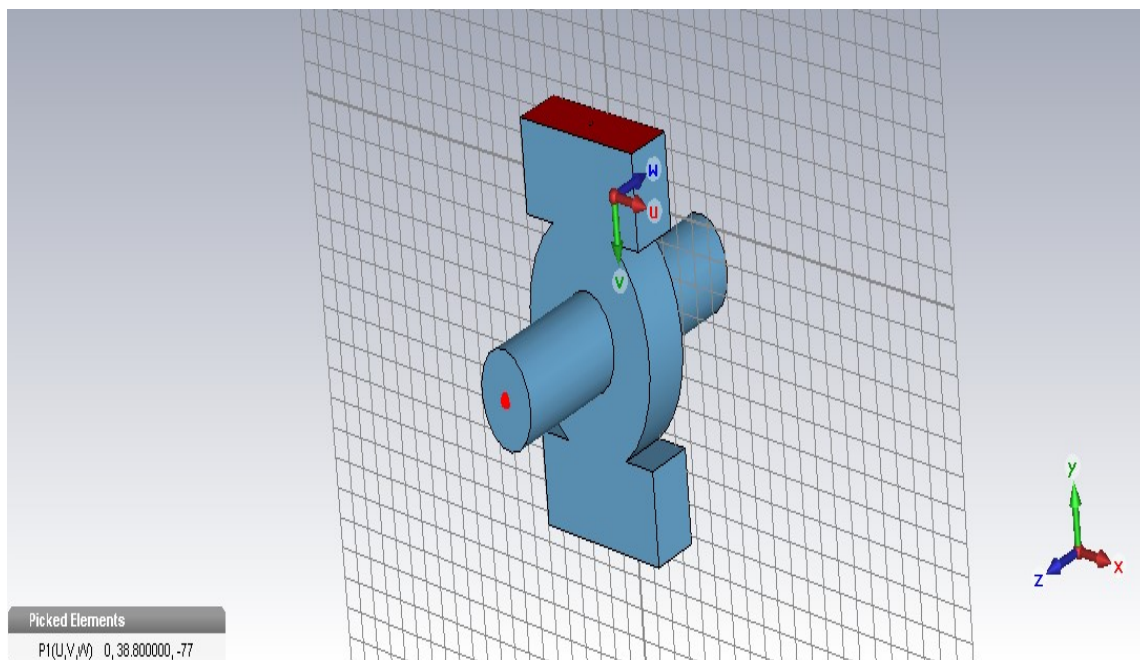

Figure 4.5 Rectangular klystron tube simulated

The basic aim of this simulation is to find the Quality factor of the given klystron tube which is the basic parameter to pronounce the standard of performance when compared with the

other cavity designed. Once we design the cavity we can get the Q-factor of the designed cavity at the specified frequency directly through simulation.

The parameters on the basis of which the cavity is designed using the analytical equations is given in Table 4.1. These parameters are specified for 2.7GHz frequency generation.

Quantity	Value
Cavity Length L_{cav} ,mm	22
Drift Tube length L_{tub} , mm	110
Cavity radius R_{cav} ,mm	38.8
Length of drift tube R_{tub} ,mm	15.9
Width of the waveguide h ,mm	25
Length of the waveguide WW ,mm	36.1

Table 4.1 Cavity parameters for the frequency of 2.7 GHz

Using the dimensions given in the table, the cavity is designed working at the desired frequency. The designed cavity is shown in Figure 4.6.

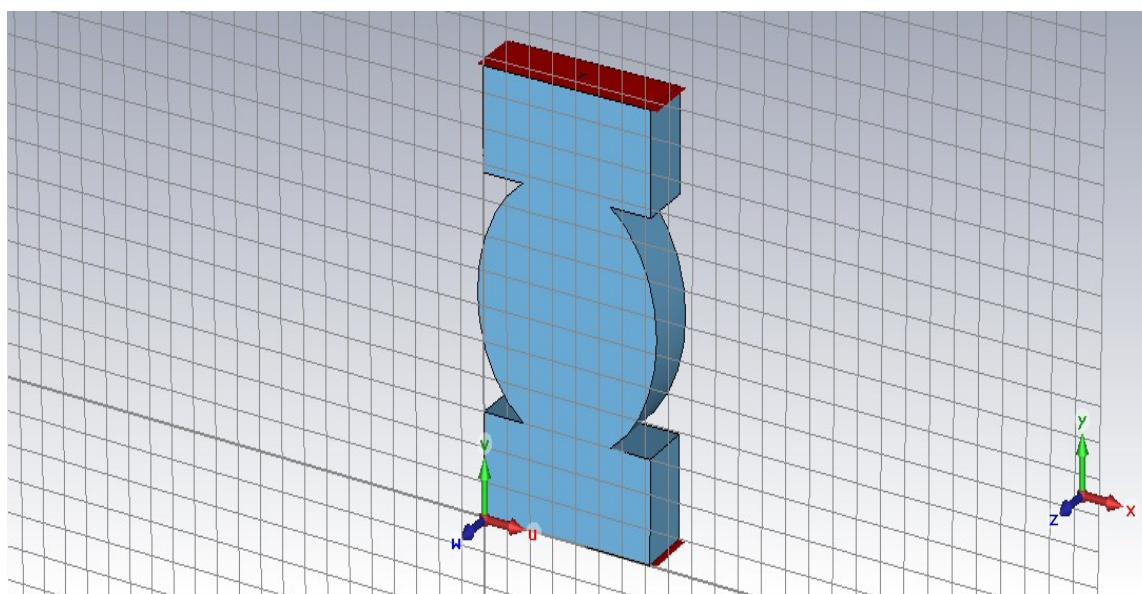

Figure 4.6 Cavity designed according to the dimensions stated above.

To make the cavity work at some other frequency, different dimensions of L_{cav} , R_{cav} , L_{tub} , R_{tub} , WW and h would be required. According to the dimensions given in Table 4.1 we get the cavity model as shown in Figure 4.6. The change in electric and magnetic components of the cavity affects the frequency. Hence to design a klystron tube of different frequency, we need to make such change in the cavity which affects the electric and magnetic fields of the cavity.

4.4 DEFORMED KLYSTRON CAVITY

A new cavity has been designed with the same parameters as the original cavity but with a deformation which is called cavity perturbation. In cavity perturbation a small foreign object is introduced in the cavity or distortion of the boundary of the cavity is done so as to change the performance of the cavity resonator[26].

In this a small cylinder is introduced as a foreign object in the cavity initially designed to accomplish the aim of cavity perturbation. The parameters of the cavity designed remains the same i.e. L_{cav} , R_{cav} , L_{tub} , R_{tub} , h and WW . Along with these the parameters of the cylinder being introduced is added in the parameter list of the new designed cavity which is shown in Table 4.2.

Quantity	Value
Cavity Length L_{cav} ,mm	22
Drift Tube length L_{tub} , mm	110
Cavity radius R_{cav} ,mm	38.8
Length of drift tube R_{tub} ,mm	15.9
Width of the waveguide h ,mm	25
Length of the waveguide WW ,mm	36.1
Height of the foreign object(cylinder), mm	10
Radius of the foreign object(cylinder), mm	10

Table 4.2 Parameters for cavity of the frequency of 2.7 GHz after cavity perturbation

The design of the cavity stated above is given in Figure 4.7. The cavity perturbation is essentially based on the assumption that to keep the electric field which is outside the sample, undistributed, the size of the object need to be much smaller than that of the cavity.[31].The condition of foreign object having smaller dimensions need to be fulfilled so as to achieve perturbation of the initial cavity.

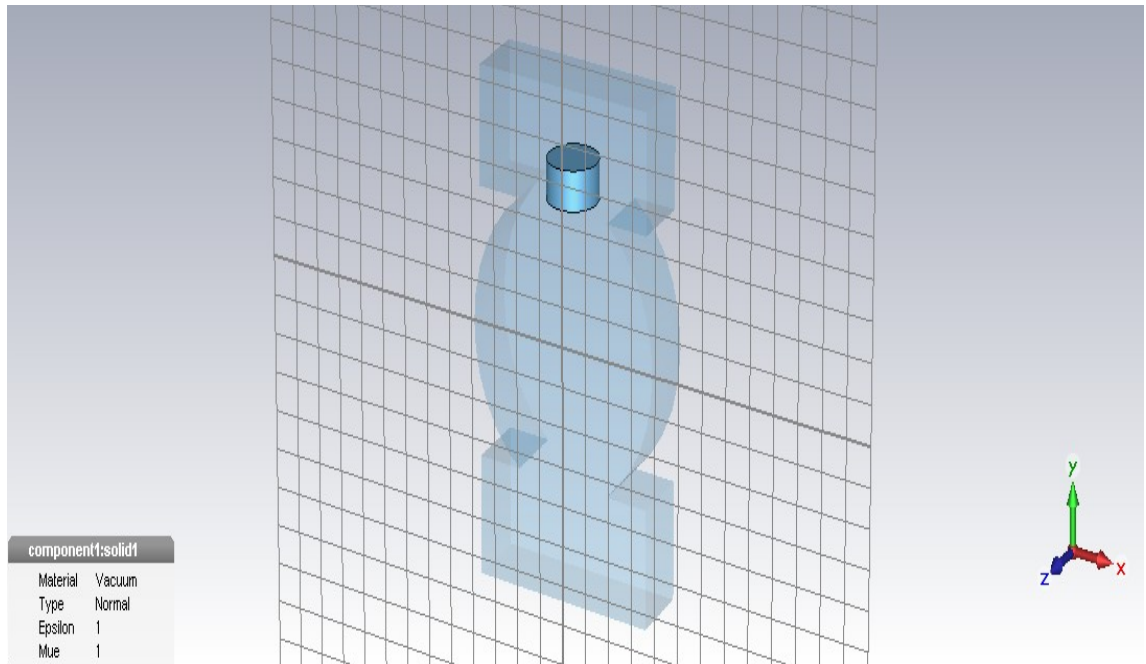

Figure 4.7 Designed cavity with introduction of small cylindrical foreign object

In this case too, we get the frequency of 2.7 GHz with some changes in the performance parameters of the cavity. Basically the quantities which gets affected are-

- Frequency(minute)
- Broadening of the resonance width
- Increase in Q-factor

More or less the frequency of both the cavities approximately remains same. The third quantity resonance width is connected to the frequency and as there is no change in the frequency of the distorted cavity, no change in resonance width is encountered. Moreover it is not a parameter of concern when working at same output frequencies.

Except these parameters of the designed cavity such as S-parameter and Q-factor that have been estimated above, there are many more such as electric and magnetic fields, excitation signals, modes at the port etc which also define the type of cavity that has been designed. The electric field and magnetic field of the klystron cavity designed comes out to be 721 V/m and 1.72 Wb/m² approximately. As the magnetic and electric field change its pattern the frequency of the klystron cavity changes thus changing its areas of application. One of the ways of changing these fields have been stated i.e. cavity perturbation whereas there are many others such as coating the cavity with some other material to improve efficiency, changing the dimensions of the cavity to some extent etc. The specific fields of a designed cavity is due to its dimensions which provide a specific frequency and a Q-factor as well. Every parameter is correlated and so is the efficiency of the tube.

Other than these the excitation signal that is being provided to the cavity is a parameter that makes the difference. The signal used by default for excitation is the Gaussian signal. The reason for using this signal is that the electron bunches are more dense in the middle than at the sides, thus making the output results more accurate than using any other signal for excitation.

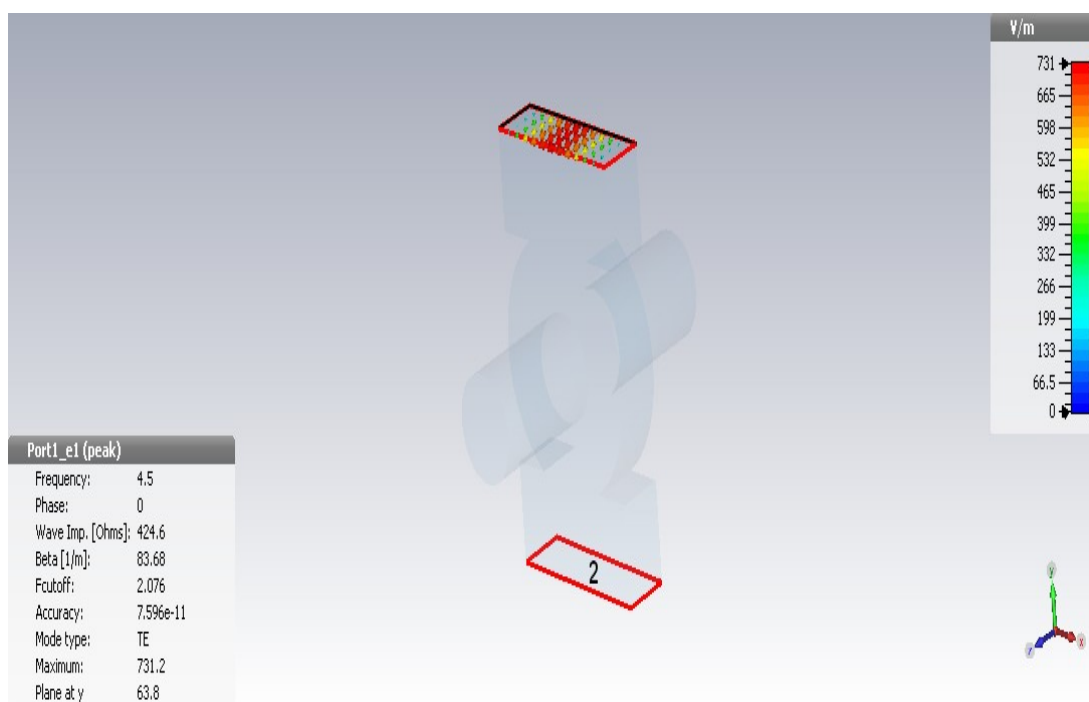

Figure 4.8 Electric field pattern at port 1

There are four modes at the ports which can be processed after the simulation. These are helpful for finding the S-parameters of the cavity. Moreover different modes of the same cavity have their own electric and magnetic fields. These fields can be observed to find out which type of mode one is working in i.e. transverse electric, transverse magnetic and transverse electric magnetic etc further specifying the M and N in the TM_{MN} or TE_{MN} etc.

The electric and magnetic field patterns of the klystron cavity being designed is shown below in the figure 4.8 and 4.9 respectively . Further these patterns vary for different modes.

The magnetic and electric field altogether are responsible for the output response of the cavity being designed. The parameters being affected by these fields are output frequency, output power, energy, flow of electrons through the tube, the output velocity etc.

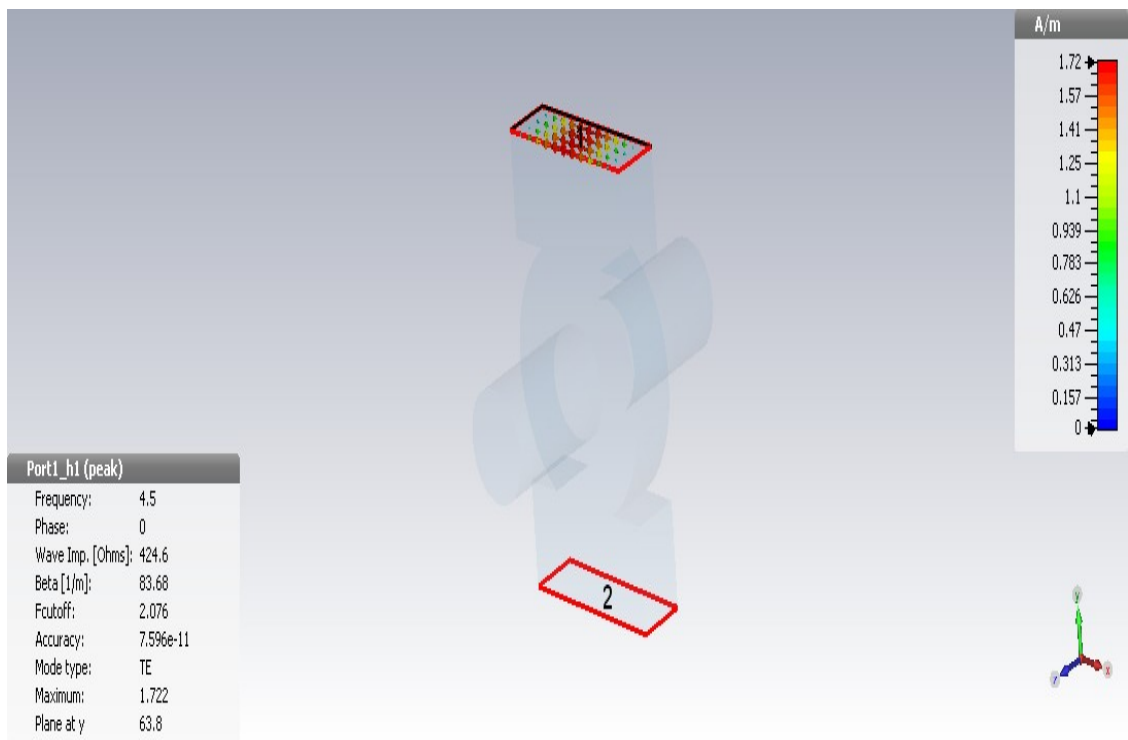

Figure 4.9 Magnetic field pattern at port 1

. Hence by controlling the magnetic and electric fields the cavity of different frequencies can be designed as desired and according to the applications. So designing the cavity structures need to be a cautious work, it can be verified by using various formulae to determine the length and radius of cavity along with the length and cavity of the tube.

CHAPTER 5

RESULTS AND DISCUSSION

5.1 RESULTS

The klystron tube and then the respective cavities are first designed in the software, then simulation is done based on CST studio suite software. The Eigen mode, time domain solver and PIC simulation are the basic features that are used so as to get the desired results. The S-parameters, electric and magnetic fields, Q-factor and frequency are the basic parameters that are calculated after the simulation.

- First of all the round beam klystron cavity having a reentrant cylindrical klystron cavity and drift tube are designed . Then the designed circuit is simulated in the software CST as shown in the figure 5.1 given below-

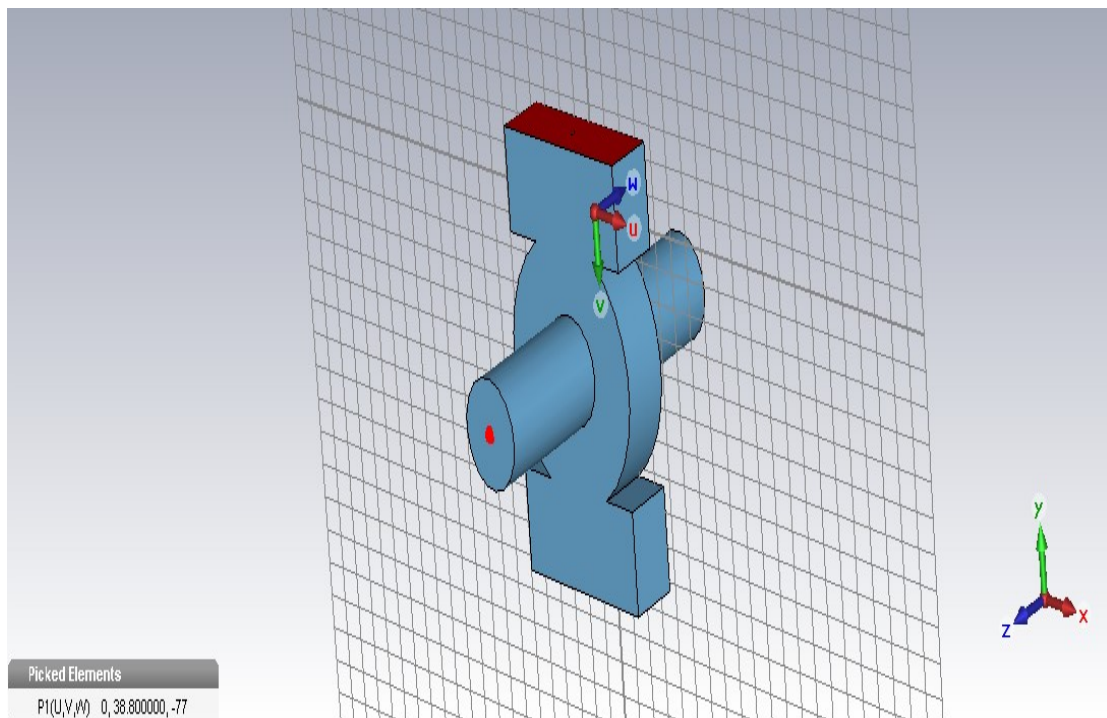

Figure 5.1 Designed klystron cavity in CST

- Gaussian input is given at one end of the drift tube as the input. Gaussian is used so as to make the spatial distribution of the charged particles is defined to be uniform over the emission surfaces cross section. The Gaussian excitation input signal is shown in Figure 5.2.

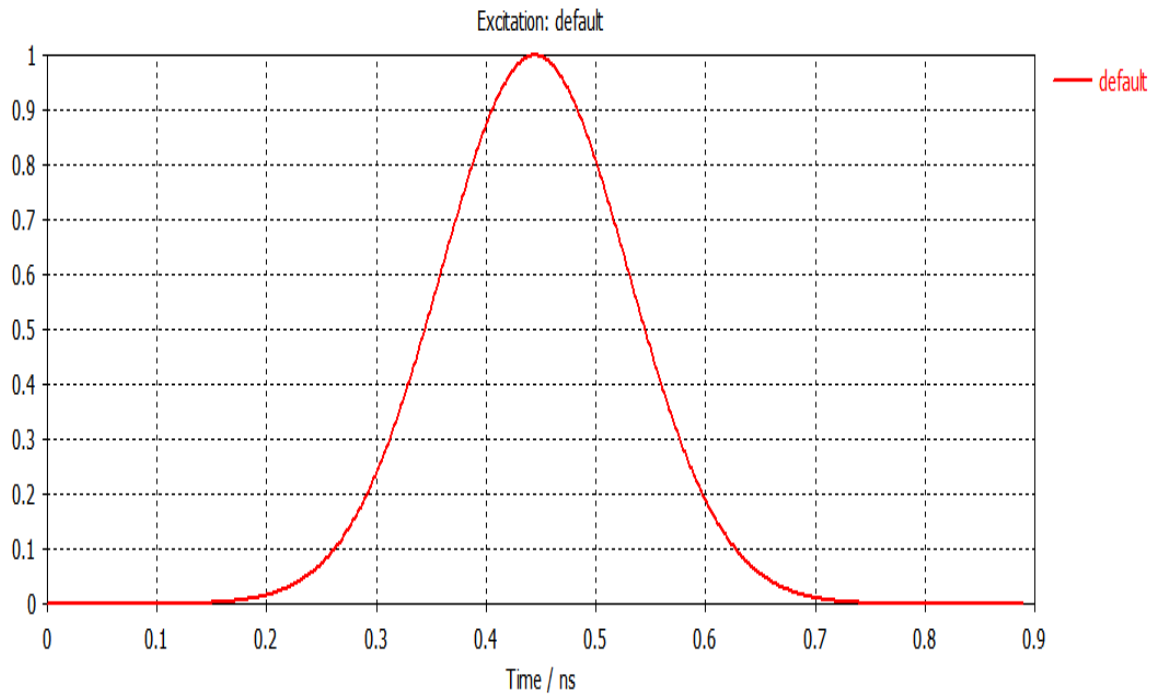

Figure 5.2 Excitation signal

- The output or results for the cavity are generated in the presence of predefined constant magnetic field whose magnitude is 0.2 Wb/m^2 which is as shown in figure 5.3 below. The change in the velocity of electrons take place due to the magnetic and electric fields that are present inside and outside the cavity that has been designed. Hence it plays a vital role in getting the desired frequency during the simulation of the cavity.

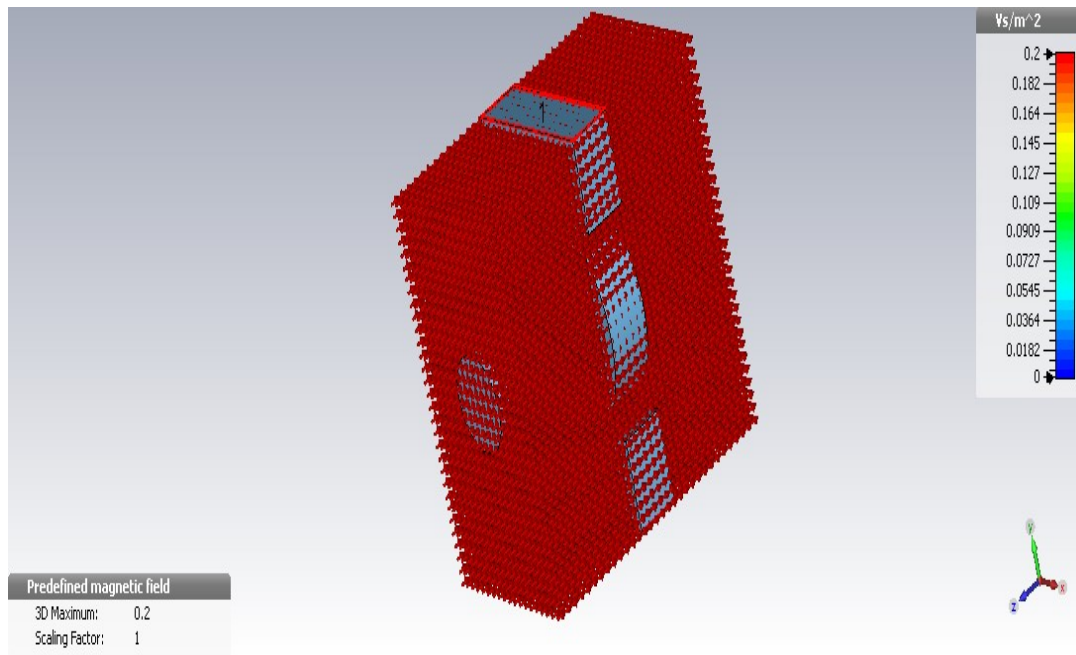

Figure 5.3 The predefined magnetic field

- Under these two signals the klystron cavity is simulated the output we get is the amplified input signal as klystron cavity works as the amplifier, hence we get the desired result.

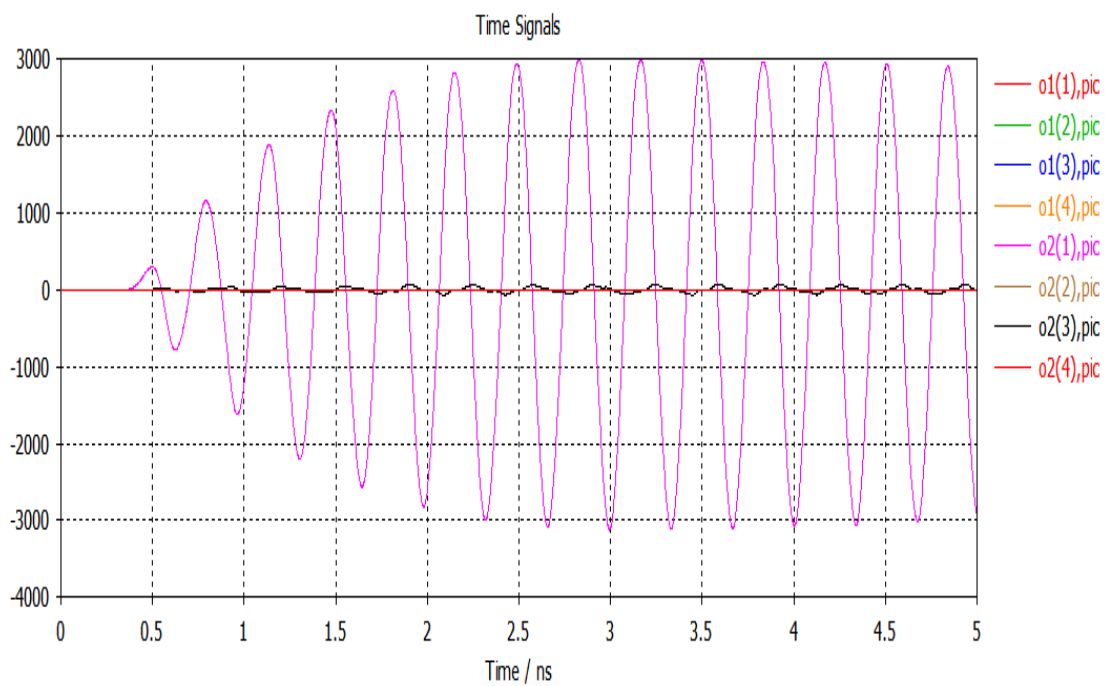

Figure 5.4 Output amplified signal at the waveguide ports

- We can also view the time dependent electric field caused by the movement of the charged particles and particle trajectory of the klystron cavity designed. This can be viewed by using the mesh view of the software. At any point of the designed cavity we can check the values of magnetic field and electric field. These values can be used for calculations in many formulae to find the theoretical values of frequency, resistance and Q- factor etc. The mesh view of the cavity being designed is shown in figure 5.5.
- As PIC i.e. particle in cell simulation is used for the klystron tube, the output shows the particle trajectory through the tube of the cavity along with the electric and magnetic field changes at various points of the tube. Particle view of the tube is shown in figure 5.6 depicting the movement of the electrons and their changes as they are moving through the cavity.

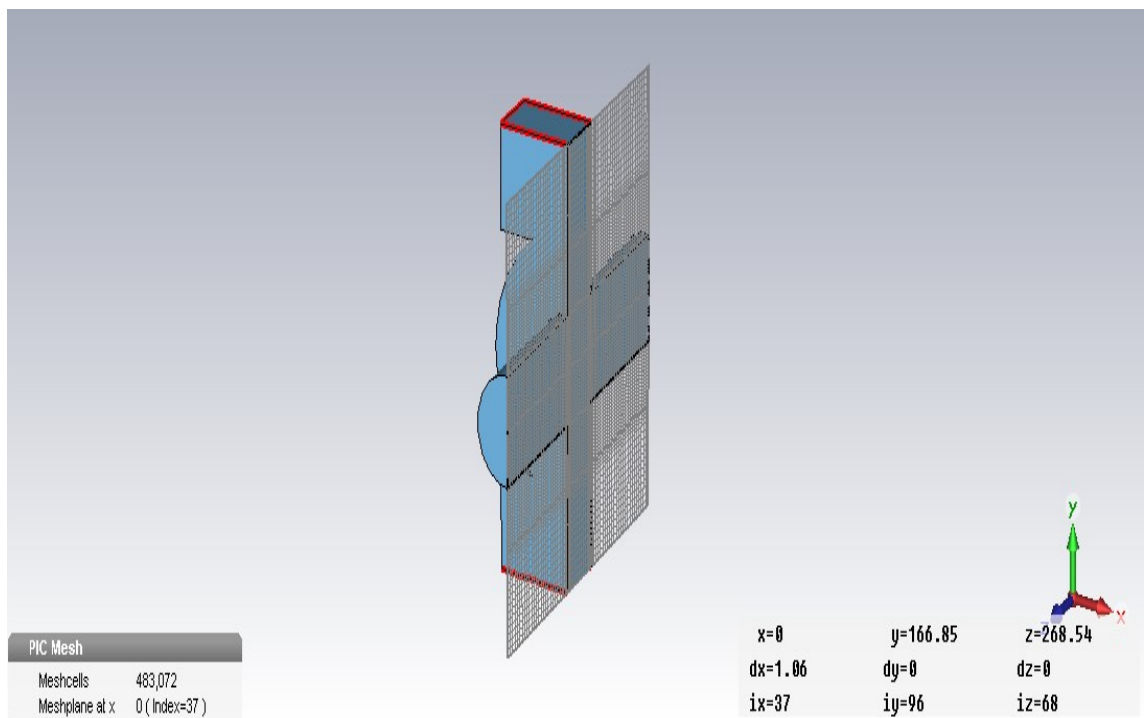

Figure 5.5 Mesh control view

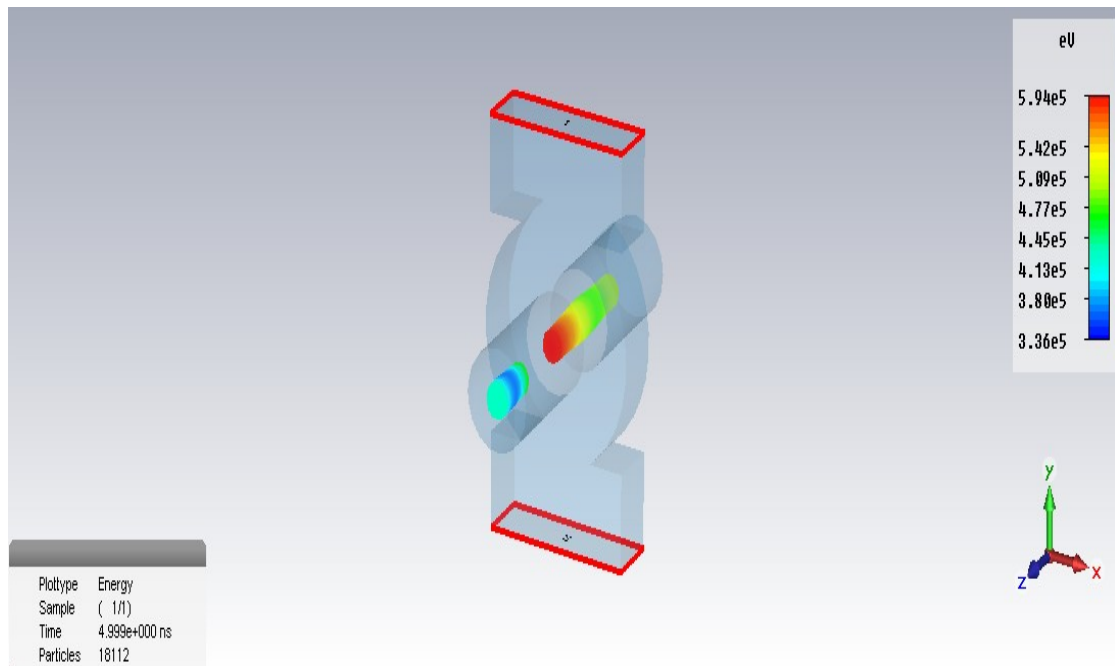

Figure 5.6 The particle view of klystron in PIC simulation

- The next simulation after that of klystron tube is that of klystron cavity simple and with cavity perturbation in Eigen mode as well as time domain analysis. The klystron cavity being designed is as given below in Figure 5.7.

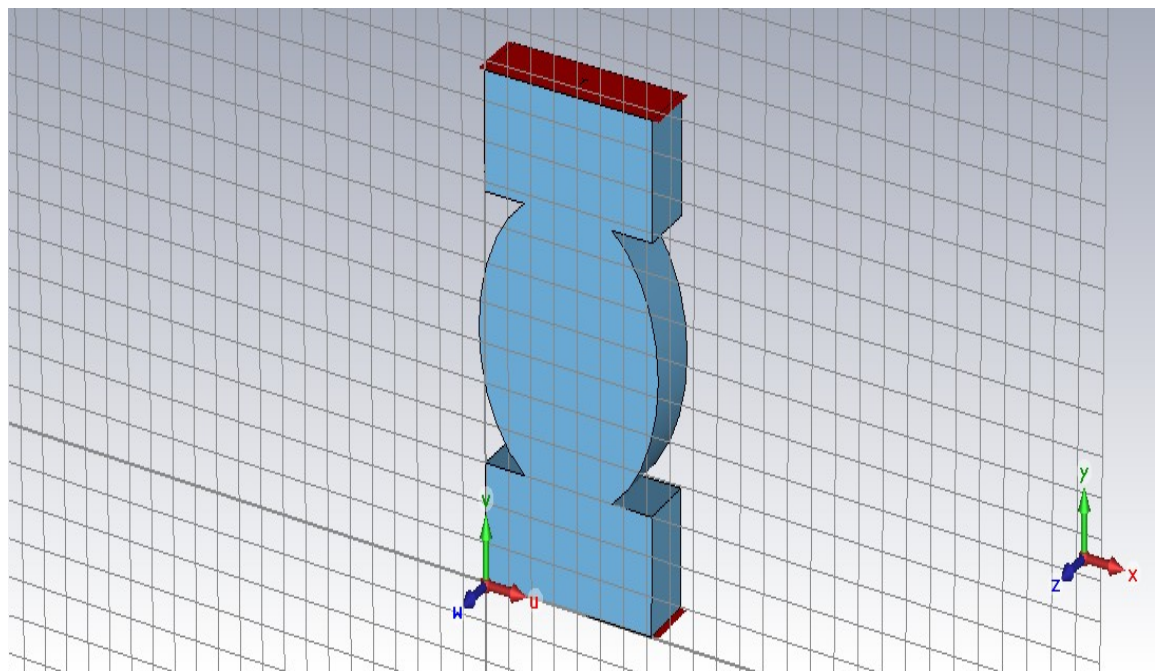

Figure 5.7 The designed cavity

- The results of the simple klystron cavity being designed is as given in figure 5.8.

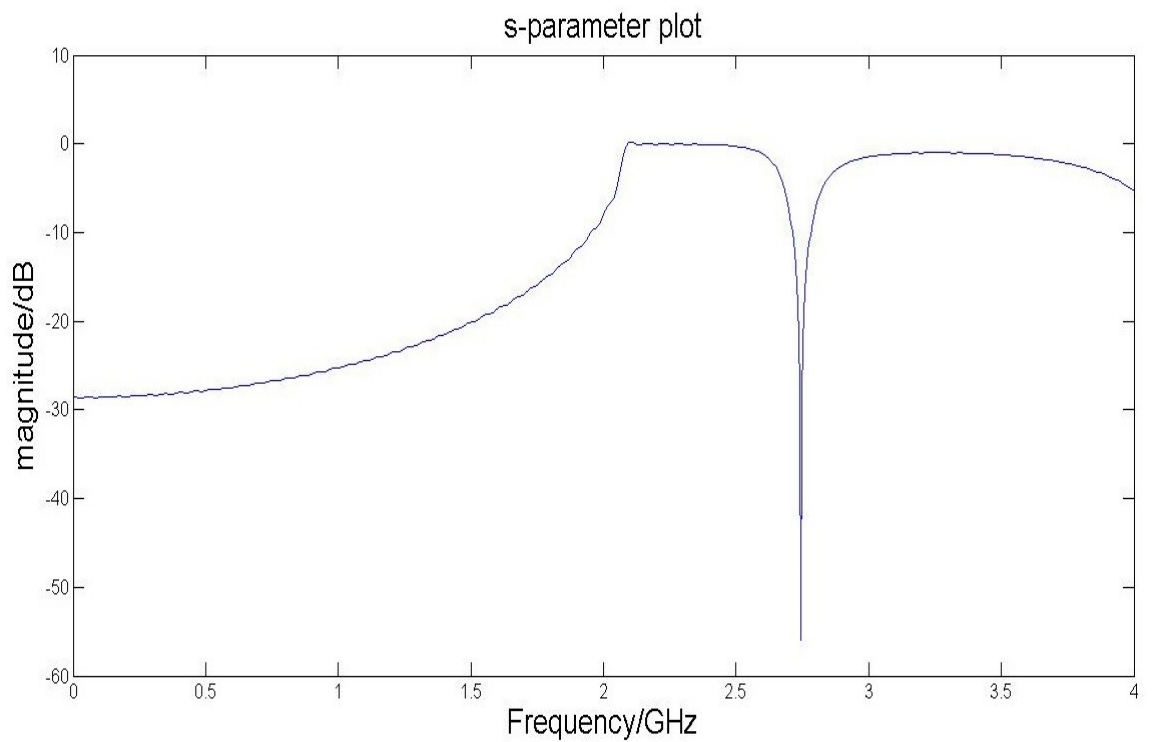

Figure 5.8 S-parameter graph of the cavity showing 2.7GHz as the output frequency.

- The perturbed klystron cavity to improve the Q-factor or efficiency of the original cavity being designed along with the results that are obtained are as given in figure 5.9 and figure 5.10 respectively.

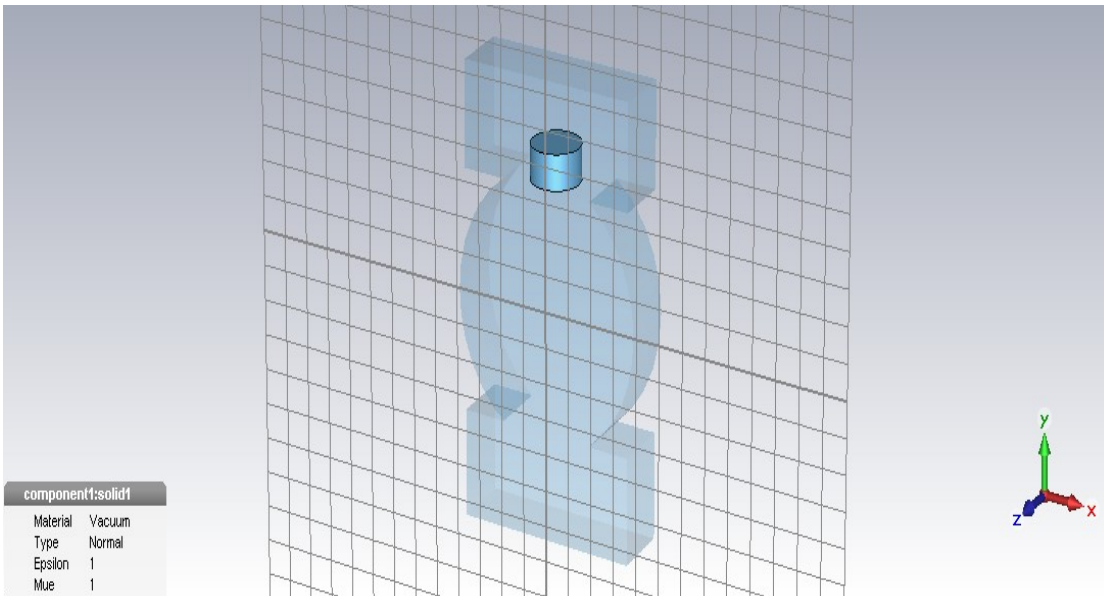

Figure 5.9 Designed cavity with introduction of small cylindrical foreign object.

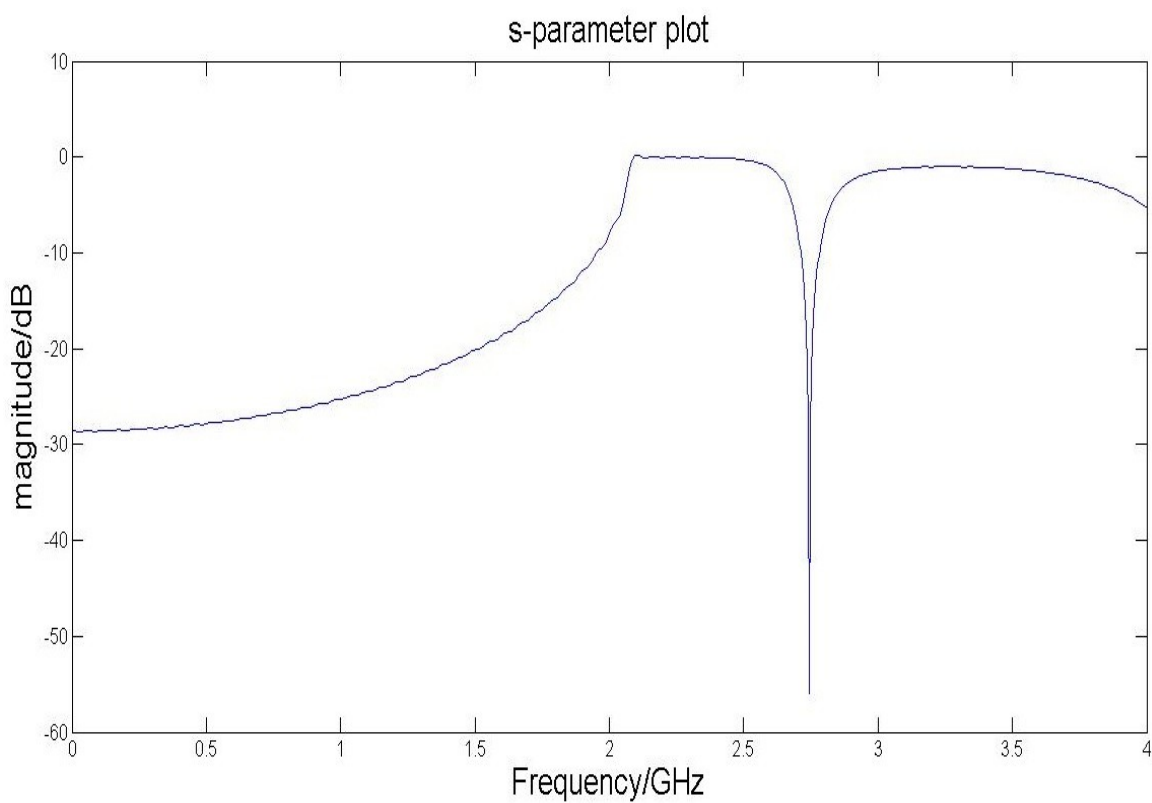

Figure 5.10 Output frequency of the deformed cavity through S-parameter graph which is approximately 2.7 GHz.

The parameter for deciding the better results out of both the cavities is Q-factor. Quality factor need to be improved by different methods mentioned above, out of all as cavity perturbation is

used in this work Q-factor of both cavities designed can be compared. The results of both the cavities after simulation is given in Table 5.1.

Quantity	Value	
	<i>Cavity</i>	<i>Perturbated Cavity</i>
Frequency f, GHz	2.7	2.7
Q-Factor	12695	13304

Table 5.1. Comparison of results of klystron cavity and after cavity perturbation

The table formulated is the base of the conclusions being made.

CHAPTER 6

CONCLUDING REMARKS AND FUTURE SCOPE

6.1 CONCLUSION

- It can be concluded on comparing the results of the two simulations that introducing a foreign substance or any kind of deformity in the cavity i.e. cavity perturbation leads to improved results or Q-factor of the same cavity, with very negligible changes in the frequency of the cavity. In this paper the frequency remains 2.7GHz in the cavities being designed. Hence cavity perturbation can be used at high frequency cavity designing to improve the performance at the same frequency.
- The designed klystron cavity was refined to the point where it can serve as power amplifier and oscillator devices in a better way. It can produce high power outputs than some solid state devices.
- klystron cavity in this work has been projected as an oscillator which find its use in high-power, high-frequency radio transmitters and in scientific research applications hence this improved quality enhances the efficiency or working of the designed tube in these fields.
- In radar systems vacuum tubes technology is preferred because of being more affordable than solid state devices. Hence the requirement of klystron tubes in such significant fields make it important to improve the quality of the appliance for best results[11].

6.2 FUTURE SCOPE

The future of the tubes seem to be promising in various fields. Some of the fields are as given below-

- The research in this field can further be applied to the multiple cavity klystrons, the different cavities in such equipment are not synchronized with one another due to various types of losses on transfer of fields and energy from one cavity to another. Hence the method of cavity perturbation can be used to improve the efficiency of such multiple cavity klystrons.

- Vacuum electronics including devices like magnetrons and gyro klystrons are needed with improved performance so that they can be used more reliably in military field. Hence devising some methods of remodeling such RF devices using cavity perturbation technique as basic cannot be ruled out.
- Devices like gyro-TWTs, klystrons providing high power at high frequency with wide bandwidth and better efficiency make the future developments appear secure[11], so need to be made efficient via methods like cavity perturbation, electroplating etc.

REFERENCES

- [1] Eroglu A. *Introduction to RF Power Amplifier Design and Simulation*. USA: CRC Press, 2015.
- [2] Fuentes C. *Microwave Power Amplifier Fundamentals*. USA: Giga-tronics Incorporated, 2008.
- [3] Raab FH *et al.* (2003). High Frequency Electronics: *RF and Microwave Power Amplifier and Transmitter Technologies*, pp. 22-54.
- [4] Srimuang P, Puangngernmak N and Chalermwisutkul S. (2014). 13.56 MHz class E power amplifier with 94.6% efficiency and 31 watts output power for RF heating applications, *International conference on electrical engineering/electronics, Computer, Telecommunications and Information Technology* [11th: Nakhon Ratchasima, Thailand: 2014], pp. 1-5.
- [5] Bryon WJ (1994). Arcs and sparks, Part 1. *Communications Quarterly, Institute of Electrical and Electronics Engineers(IEEE)*, 4(2), 27-43.
- [6] Bryon WJ (1998). The arc method of producing continuous waves. *Communications Quarterly, Institute of Electrical and Electronics Engineers(IEEE)*, 8(3), 47-65.
- [7] MacIlvain KM and Freedman WH. *Radio Library, Vol. III: Radio Transmitters and Carrier Currents*. Scranton PA: International Textbook Company. 2008.
- [8] Guarnieri M (2012). The age of vacuum tubes: Early devices and the rise of radio communications. *Institute of Electrical and Electronics Engineers(IEEE) Ind. Electron*, 6(1), 41-43.
- [9] Yingst TE *et al.* (1973). high-power gridded tubes. *proceedings of the Institute of Electrical and Electronics Engineers(IEEE)*. 61(3), 357 - 381.
- [10] Seely S. *Radio Electronics*. New York, London: McGraw-Hill Electrical and Electronic Engineering Series, 1956.
- [11] Levush B (2007). Vacuum Electronics: Status and Trends, *Institute of Electrical and Electronics Engineers(IEEE) Radar Conference* [Boston, USA: 2007], pp 971-976.
- [12] Barbour E (1998). The cool sound of tubes, *Institute of Electrical and Electronics Engineers(IEEE) spectrum*, 35(8), 24-35.
- [13] Qiu JX *et al.* (2009). Vacuum tube amplifiers, *Institute of Electrical and Electronics Engineers(IEEE) Microwave Magazine*, 10, 38 - 51.
- [14] e Silva RKB and Motta CC. (2013). Design and Simulation of a 1.3 GHz Input Klystron Cavity, *International Microwave & Optoelectronics Conference* [Rio de Janeiro, Brazil: 2013], pp: 1-5.
- [15] Jeon SG *et al.* (2006). 3-D PIC Simulations of 0.3THz Reflex Klystron, *International Conference on Terahertz Electronics* [31st: Shanghai, China: 2006], pp: 588-588.
- [16] Kuper JBH. *Vacuum Tubes Fundamentals*.
- [17] Gao DP *et al.* (2010). Development of a 2.5-Dimensional Particle-In-Cell Code for Efficient High-Power Klystron Design, *Institute of Electrical and Electronics Engineers(IEEE) Transactions on Plasma Science*, 38(6), 1277-1284.
- [18] CST. 2014. *Computer Simulation Technology* .CST STUDIO SUITE™ 2014 getting started.

- [19] Edgecombe CJ and O'Loughlin CN. The Television Performance of the Klystron Amplifier, *Institution of Engineering and Technology (IET)*, 41(9), 405-415.
- [20] Kako E *et al.* (1999). Improvement of cavity performance by electropolishing in the 1.3 GHz Nb superconducting cavities, *In proceedings of particle accelerator conference* [New York, USA: 1999], pp: 432-434.
- [21] Kniesel P. (1988). Use of the Titanium Solid State Gettering Process for the Improvement of the Performance of Superconducting RF Cavities, *Journal of Less Common Metals*, 139(1), 179-188.
- [22] Spencer EG, LeCraw R C and Ault L A. (1957). Note on cavity perturbation theory, *Journal of Applied Physics*, 28, 130-132.
- [23] Parakash A, Vaid JK and Mansingh A. (1979). Measurement of dielectric parameters at microwave frequencies by cavity-perturbation technique, *Institute of Electrical and Electronics Engineers(IEEE) Transaction of Microwave Theory and Techniques*, 27 (9), 791-793.
- [24] Estin AJ and Bussey HE. (1960). Errors in dielectric measurements due to a sample insertion hole in a cavity, *IRE Transaction of Microwave Theory and Techniques*, 8 (6), 650- 653.
- [25] Chen L, Ong CK and Tan BTG. (1999). Amendment of cavity perturbation method for permittivity measurement of extremely low-loss dielectrics, *Institute of Electrical and Electronics Engineers(IEEE) Transaction on Instrumentation and measurement*, 48 (6), 1031-1037.
- [26] Miura T *et al.* (2015). Q-factor change of cavity by sample installation in resonance perturbation method, *European microwave conference*[Paris, France: 2015], pp: 738-741.
- [27] Petersan P J and Anlage SM. (1998). *Measurement of resonant frequency and quality factor of microwave resonators*, Comparison of methods in *Journal of Applied Physics*, 84, 3392-3402.
- [28] Leong K and Mazierska J. (2002). Precise Measurements of the Q-factor of the Dielectric Resonators in Transmission Mode: Accounting for Noise, Crosstalk, Delay of Uncalibrated Lines, Coupling Loss, and Coupling Reactance, *Institute of Electrical and Electronics Engineers(IEEE) Transaction of Microwave Theory and Techniques*, 50 , 2115-2127.
- [29] Coakley KJ *et al.* (2003). Estimation of Q-Factors and Resonant Frequencies, *Institute of Electrical and Electronics Engineers(IEEE) Transaction of Microwave Theory and Techniques*, 51, 862-868.
- [30] Miura T, Takahashi T and Kobayashi M. (1994). Accurate Q-factor evaluation by resonance curve area method and its application to the cavity perturbation, *The institute of electronics, information and communication (IEICE) Transaction of Electronics*, 77, 900-907.
- [31] Wang ZH, Javadi HHS and Epstein AJ. (1991). Application of microwave cavity perturbation techniques in conducting polymers. *In proceedings of Institute of Electrical and Electronics Engineers(IEEE) Transaction on Instrumentation and measurement conference*[8th: Atlanta, USA: 1991], pp: 79-82.

LIST OF PUBLICATIONS

CONFERENCE

- Bhushan S and Yadav RP. (2017). Improving Q-factor of klystron cavity using cavity perturbation, *International conference on research trends in Engineering, Applied science and management (ICRTESM)* [3rd: Pune, India: 2017], pp: 215-219.(published)
- Bhushan S and Yadav RP. (2017). Cavity Perturbation method for improvement of klystron performance, *International microwave and RF(IMaRC) conference Institute of Electrical and Electroics Engineers Transaction of Microwave Theory and Techniques (IEEE-MTT)* [5th: Ahmedabad, India: 2017]. (communicating)

JOURNAL

- Bhushan S and Yadav RP. (2017). Improving Q-factor of klystron cavity using cavity perturbation, *International journal of Electronics, Electrical and computational System (IJECS)*, 6(5), 405-409.(published)

ORIGINALITY REPORT

% **14**
SIMILARITY INDEX

% **11**
INTERNET SOURCES

% **6**
PUBLICATIONS

% **2**
STUDENT PAPERS

PRIMARY SOURCES

1 docslide.us Internet Source % **3**

2 www.ee.pucrs.br Internet Source % **3**

3 palaplayitaxd.blogspot.com Internet Source % **1**

4 www.mwjjournal.com Internet Source % **1**

5 Silva, Robson K. B. e, and Claudio C. Motta. "Design and simulation of a 1.3 GHz input klystron cavity", 2013 SBMO/IEEE MTT-S International Microwave & Optoelectronics Conference (IMOC), 2013. Publication % **1**

6 Dong-Ping Gao, , Chao-Hai Du, Yao-Gen Ding, and Pu-Kun Liu. "Development of a 2.5-Dimensional Particle-In-Cell Code for Efficient High-Power Klystron Design", IEEE Transactions on Plasma Science, 2010. Publication <% **1**

7

Chae-Hwa Shon. "3-D PIC Simulations of 0.3THz Reflex Klystrons", 2006 Joint 31st International Conference on Infrared Millimeter Waves and 14th International Conference on Terahertz Electronics, 09/2006

Publication

<% 1

8

en.wikipedia.org

Internet Source

<% 1

9

hadmernok.hu

Internet Source

<% 1

10

Foulds, K.W.H.. "Resonant-cavity measurements of the relative permittivity of a d.c. discharge", Proceedings of the IEE Part C Monographs, 1955.

Publication

<% 1

11

Baruch Levush. "", IEEE Aerospace and Electronic Systems Magazine, 9/2007

Publication

<% 1

12

www.cst-china.cn

Internet Source

<% 1

13

Hao Fu; Xia Xiao; Jiantong Li and Yong Zong. "Study on a Glucose Concentration Measurement System Based on Microwave Perturbation Technique", Journal of Microwave Power & Electromagnetic Energy, 2015.

Publication

<% 1

14

www.deepdyve.com

Internet Source

<% 1

15

Masaaki Ikeda. "Influence of strength and asymmetry of the coupling between a cavity and a transmission line on measurement of complex permittivity", Microwave and Optical Technology Letters, 03/2010

Publication

<% 1

16

T.E. Yingst, D.R. Carter, J.A. Eshleman, J.M. Pawlikowski. "High-power gridded tubes—1972", Proceedings of the IEEE, 1973

Publication

<% 1

17

K.T. Mathew. "Cavity Perturbation Techniques for Measuring Dielectric Parameters of Water and Other Allied Liquids", Sensors Update, 01/2000

Publication

<% 1

18

Qiu, J.X., B. Levush, J. Pasour, A. Katz, C.M. Armstrong, D.R. Whaley, J. Tucek, K. Kreischer, and D. Gallagher. "Vacuum tube amplifiers", IEEE Microwave Magazine, 2009.

Publication

<% 1

19

Paul J. Petersan. "Measurement of resonant frequency and quality factor of microwave resonators: Comparison of methods", Journal of Applied Physics, 1998

Publication

<% 1

20

www.aoe.vt.edu

Internet Source

<% 1

21

Leong, Kenneth Mazierska, Janina. "Precise measurements of the Q factor of dielectric resonators in the transmission mode-- accounting f", IEEE Transactions on Microwave Theory an, Sept 2002 Issue

Publication

<% 1

22

researchonline.jcu.edu.au

Internet Source

<% 1

23

Submitted to The University of Manchester

Student Paper

<% 1

24

library2.usask.ca

Internet Source

<% 1

25

Yongchun Zheng. "Measurement of the complex permittivity of dry rocks and minerals: application of polythene dilution method and Lichtenecker's mixture formulae", Geophysical Journal International, 10/31/2005

Publication

<% 1

26

Mukherjee, Ishita, and Reuven Gordon. "Analysis of hybrid plasmonic-photonic crystal structures using perturbation theory", Optics Express, 2012.

Publication

<% 1

www.tqs.com

27

Internet Source

<% 1

28

Submitted to British University in Egypt

Student Paper

<% 1

29

Yan, Qiong, Lin Hua, Chun-Qi Shi, Run-Xi Zhang, and Zong-Sheng Lai. "A fully integrated 0.35 μ m SiGe power amplifier design", 2012 IEEE 11th International Conference on Solid-State and Integrated Circuit Technology, 2012.

Publication

<% 1

30

Wang, Nannan, and Peng Wang. "Study and application status of microwave in organic wastewater treatment – A review", Chemical Engineering Journal, 2016.

Publication

<% 1

31

Sheila Oree. "A Modified Cavity Perturbation Technique for Measurement of the Dielectric Constant of High Permittivity Materials", Advances in Microwave and Radio Frequency Processing, 2006

Publication

<% 1

EXCLUDE QUOTES ON

EXCLUDE MATCHES < 10 WORDS

EXCLUDE BIBLIOGRAPHY ON