

HYBRID BEAMFORMING FOR CODED MU MASSIVE MIMO-OFDM SYSTEM

A Thesis Submitted in Partial Fulfillment of the Requirement for the Award of the Degree of

MASTER OF ENGINEERING

In

Electronics and Communication

Submitted By

HARLEEN KAUR

801661008

Under Supervision of

Dr. Ankush Kansal

Assistant Professor, ECED



THAPAR INSTITUTE
OF ENGINEERING & TECHNOLOGY
(Deemed to be University)

ELECTRONICS AND COMMUNICATION ENGINEERING DEPARTMENT

THAPAR INSTITUTE OF ENGINEERING & TECHNOLOGY

(A DEEMED TO BE UNIVERSITY), PATIALA, PUNJAB

JULY, 2018

DECLARATION

I, Harleen Kaur hereby declare that the work presented in this thesis entitled "Hybrid Beamforming For Coded MU Massive MIMO-OFDM System" in partial fulfillment of the requirement for the award of degree of Master of Engineering submitted at Electronics and Communication Engineering Department, Thapar Institute of Engineering & Technology (Deemed to be University), Patiala is an authentic record of work carried out under supervision of Dr. Ankush Kansal (Assistant Professor, ECED, Thapar Institute of Engineering & Technology) from 2016 to 2018. The matter presented in this has not been submitted either in part or full to any other university or institute for the award of any other degree.

Date: 17/8/18

Harleen Kaur

Harleen Kaur

801661008

It is certified that the above statement made by the candidate is correct to the best of my knowledge and belief.

Date: 17/8/18

Ankush Kansal

Dr. Ankush Kansal

Assistant Professor, ECED

ACKNOWLEDGEMENT

I would like to express my gratitude to **Dr. Ankush Kansal, Assistant Professor**, Electronics and Communication Engineering Department, Thapar Institute of Engineering and Technology, Patiala for his patient guidance and support throughout this thesis report. I am truly very fortunate to have the opportunity to work with him. I found this guidance to be extremely valuable. I am also thankful to our Head of Department, **Dr. Alpana Agarwal** and P.G. Coordinator, **Dr. Amit Mishra**. I would like to thank the entire faculty and staff of Electronics and Communication Engineering Department and then friends who devoted their valuable time and help me in all possible ways towards successful completion of this work. I thank all those who have contributed directly or indirectly to this work. Lastly, I would like to thank my parents for their years of unyielding love and encourage they have always wanted the best for me and I admire their determination and sacrifice.

Harleen Kaur
ME (ECE)
801661008

ABSTRACT

With the ascent in users of Internet of Things and mobile data, an enormous growth has been noticed in the usage of data in recent years and if this trend remains unchanged, it will increase as multiples of zettabytes in the near future. So, for the accomplishment of the requirements of the future generations, the (Multiuser Massive Multiple Input Multiple Output-Orthogonal Frequency Division Multiplexing) MU Massive MIMO-OFDM system is being evolved as an emerging technology. Therefore, for assessing its performance, its comparative analysis in terms of error and achievability rates has been performed with the earlier MIMO-OFDM techniques and it has been found that this scheme outperforms the earlier ones with improved rates. As for the downlink transmission case, to achieve 0.01 (Bit Error Rate) BER, (Signal to Noise Ratio) SNR required for 4x4 MIMO-OFDM system is 9dB, 8X4 MU MIMO-OFDM system is 4dB and 128x4 MU Massive MIMO-OFDM system is -3.8dB. Further for actualizing this system in practical scenarios, Phase Zero Forcing (PZF) hybrid beamforming scheme has been introduced in the system and is compared with the earlier Zero Forcing (ZF) scheme in terms of BER, achievability rate and computation complexity. From the obtained observations, it has been found that this PZF scheme performs almost equivalent to ZF scheme with small loss in system's performance which is reimbursed in terms of reduced computational complexity. This reduction in complexity for the massive MIMO system has been measured by plotting the graph for time consumption as a function of service antennas which shows that for instance of 600 service antennas, the computational time required for ZF scheme is 640 seconds whereas for PZF scheme is 250 seconds. In addition to above-mentioned analysis, one more category of comparison between the distinct FEC codes and un-coded system has been assessed and evaluated. After examining these comparisons, it has been observed that these systems surpass the performance of un-coded system but at the cost of raised computational complexity.

TABLE OF CONTENTS

Sr. No	Name of the Chapters	Page Number
	<i>Declaration</i>	<i>ii</i>
	<i>Acknowledgement</i>	<i>iii</i>
	<i>Abstract</i>	<i>iv</i>
	<i>Table of Contents</i>	<i>v</i>
	<i>List of Tables</i>	<i>vii</i>
	<i>List of Figures</i>	<i>viii</i>
	<i>List of Abbreviations</i>	<i>x</i>
<i>Chapter 1</i>	INTRODUCTION	1-17
1.1	Multiple Input and Multiple Output (MIMO) System	1
1.1.1	MIMO System Model	2
1.2	Orthogonal Frequency Division Multiplexing (OFDM) System	3
1.2.1	OFDM System Model	4
1.2.2	Functionalities of Various Operational Blocks Used in OFDM System	4
1.2.2.1	Channel Encoding and Decoding	4
1.2.2.2	Interleaving and De-interleaving	4
1.2.2.3	Serial to Parallel (S/P) Converter or Parallel to Serial (P/S) Converter	4
1.2.2.4	Inverse Fast Fourier Transform (IFFT) and Fast Fourier Transform (FFT) Operations	5
1.2.2.5	Cyclic Prefix	5
1.3	Multiuser Multiple Input and Multiple Output (MU-MIMO) System	6
1.3.1	MU-MIMO System Model	7
1.4	MIMO-OFDM System	8
1.4.1	MIMO-OFDM System Model	9
1.4.2	MU-MIMO OFDM System	10
1.5	Massive MIMO System	11
1.5.1	Types of Massive MIMO Systems	11
1.5.1.1	Massive MIMO for sub 6GHz	12
1.5.1.2	Massive MIMO for mm Wave	12
1.5.2	Massive MIMO-OFDM System	13
1.5.3	Beamforming/Precoding in Massive MIMO Systems	13
1.5.4	Hybrid Beamforming in Massive MIMO Systems	14
1.6	Forward Error Correction (FEC) Codes	15
1.6.1	Convolutional Coding	15
1.6.2	Reed Solomon (R-S) Coding	16
1.7	Framework of Thesis	17
<i>Chapter 2</i>	LITERATURE SURVEY	18-39
2.1	MIMO System	18
2.2	OFDM System	20
2.3	Multiuser MIMO System	23
2.4	MIMO-OFDM System	27
2.5	Massive MIMO System	31
2.6	Gaps Identified	37
2.7	Objectives	38
2.8	Methodology	38
<i>Chapter 3</i>	SYSTEM MODEL	40-54
3.1	Coded MU Massive MIMO-OFDM System with Conventional Linear Precoding and Decoding Schemes	40
3.1.1	Downlink/Broadcast Transmission	40

3.1.1.1	S/P De-mux	41
3.1.1.2	Encoders and Decoders	41
1.	Convolutional Codes	41
2.	Block Codes	43
3.1.1.3	Modulation and Demodulation Blocks	45
3.1.1.4	Precoding/Beamforming Techniques in Broadcast Transmission	45
1.	Maximum Ratio Transmission (MRT) Beamforming Scheme	46
2.	Zero Forcing (ZF) Beamforming Scheme	46
3.	Minimum Mean Square Error (MMSE) Beamforming Scheme	47
3.1.1.5	OFDM System	47
3.1.1.6	(Radio Frequency) RF Chain	49
3.1.1.7	Channel Model	49
3.2	Uplink/MAC Transmission	50
3.2.1	Receiver Schemes Used in Uplink Transmission	51
1.	Maximum Ratio Combining (MRC) Receiver	52
2.	Zero Forcing (ZF) Receiver	52
3.	Minimum Mean Square Error (MMSE) Receiver	52
3.3	Coded MU Massive MIMO-OFDM System with Hybrid Beamforming Scheme for Broadcast Transmission	53
<i>Chapter 4</i>	RESULTS AND DISCUSSIONS	55-66
4.1	Comparison of MIMO Technologies	55
4.1.1	Error Rate Performance	55
4.1.2	Achievability Rate Performance	57
4.2	Comparison of ZF and PZF Hybrid Beamforming Schemes in Presence of Both Coded and Un-coded Systems	59
4.2.1	Error Rate Performance	60
4.2.2	Achievability Rate Performance	62
4.2.3	Computational Complexity Analysis	63
<i>Chapter 5</i>	CONCLUSION AND FUTURE SCOPE	67-68
5.1	Conclusion	67
5.2	Future Scope	68
	References	69-71
	<i>List of Publications</i>	72

LIST OF TABLES

Sr. No	Table Details	Page Number
Table 4.1	SNR values for Downlink and Uplink Transmission of different MIMO-OFDM Systems at 0.01 BER	56
Table 4.2	Achievability Rate values for Downlink and Uplink Transmission of different MIMO-OFDM Systems at 20dB SNR	58
Table 4.3	SNR values for Un-coded, Convolutional Coded, R-S coded MU Massive MIMO-OFDM Systems with different Beamforming Schemes at 0.001 BER	60
Table 4.4	Time Consumption values for Un-coded, Convolutional Coded, R-S coded MU Massive MIMO-OFDM Systems at 600 service antennas with different Beamforming Schemes	64
Table 4.5	Time consumption values for Un-coded, Convolutional Coded, R-S coded MU Massive MIMO-OFDM Systems at 200 service antennas with different Beamforming Schemes	64

LIST OF FIGURES

Sr. No	Figure Details	Page Number
Figure 1.1	Point-to-Point MIMO System	2
Figure 1.2	General Outline of OFDM System	4
Figure 1.3	Block Diagram of MU-MIMO System	8
Figure 1.4	Basic Model of SU-MIMO OFDM System	9
Figure 1.5	System Model of MU-MIMO OFDM	10
Figure 1.6	Beamforming in LOS Scenarios	14
Figure 3.1	Block Diagram of MU Massive MIMO-OFDM System for Downlink Transmission	41
Figure 3.2	Convolutional Encoder showing $k=1$, $n=2$ and $r=1/2$	42
Figure 3.3	State Diagram representing (2,1,3) Convolutional Encoder Stages	43
Figure 3.4	R-S Code Encoder	44
Figure 3.5	Block Diagram of MU Massive MIMO-OFDM System for Uplink Transmission	51
Figure 3.6	Block Diagram of base station site of MU Massive MIMO-OFDM System with Hybrid Beamforming Scheme	53
Figure 4.1	BER versus SNR (dB) for Downlink System Model of MIMO-OFDM, MU MIMO-OFDM and MU Massive MIMO-OFDM systems	56
Figure 4.2	BER versus SNR (dB) for Uplink System Model of MIMO-OFDM, MU MIMO-OFDM and MU Massive MIMO-OFDM systems	57
Figure 4.3	Achievability rate versus SNR (dB) for Downlink System Model of MIMO-OFDM, MU MIMO-OFDM and MU Massive MIMO-OFDM systems	58
Figure 4.4	Achievability rate versus SNR (dB) for Uplink System Model of MIMO-OFDM, MU MIMO-OFDM and MU Massive MIMO-OFDM systems	59
Figure 4.5	BER versus SNR (dB) for Un-coded MU Massive MIMO-OFDM system with $M=128$ service antennas and $K=20$ user terminals for ZF and PZF beamforming schemes	61
Figure 4.6	BER versus SNR (dB) for (1/2) rate Convolutional Coded MU Massive MIMO-OFDM system with $M=128$ service antennas and $K=20$ user terminals for ZF and PZF beamforming schemes	61

Figure 4.7	BER verses SNR (dB) for (31,27) Reed-Solomon Coded MU Massive MIMO-OFDM system with M=128 service antennas and K=20 user terminals for ZF and PZF beamforming schemes	62
Figure 4.8	Achievability rate verses SNR (dB) for MU Massive MIMO-OFDM system with M=128 service antennas and K=20 user terminals for ZF and PZF beamforming schemes	63
Figure 4.9	Time (in seconds) verses service antennas with constant number of user terminals K=20 for Un-coded MU Massive MIMO-OFDM system with ZF and PZF beamforming schemes	65
Figure 4.10	Time (in seconds) verses service antennas with constant number of user terminals K=20 for (1/2) rate Convolutional Coded MU Massive MIMO-OFDM system with ZF and PZF beamforming schemes	65
Figure 4.11	Time (in seconds) verses service antennas with constant number of user terminals K=20 for (31,27) Reed-Solomon Coded MU Massive MIMO-OFDM system with ZF and PZF beamforming schemes	66

LIST OF ABBREVIATIONS

MIMO	Multiple Input Multiple Output
MRRC	Maximal-Ratio Receiver Combining
NLOS	Non-Line of Sight
SISO	Single Input Single Output
SNR	Signal to Noise Ratio
CSI	Channel State Information
STCs	Space Time Codes
STTCs	Space Time Trellis Codes
BLAST	Bell Lab Layered Space Time
STBCs	Space Time Block Codes
ZF	Zero Forcing
BER	Bit Error Rate
ISI	Inter Symbol Interference
MEAs	Multiple-Element Arrays
OFDM	Orthogonal Frequency Division Multiplexing
DSL	Digital Subscriber Line
FFT	Fast Fourier Transform
ICI	Intercarrier Interference
DFT	Discrete Fourier Transform
AWGN	Additive white Gaussian Noise
WLAN	Wireless Local Area Network
FDMA	Frequency Division Multiple Access
PAPR	Peak-to-Average Power Ratio
DMT	Discrete Multitone
D/A	Digital to Analog
S/P	Serial to Parallel
P/S	Parallel to Serial

IFFT	Inverse Fourier Transform
IDFT	Inverse Discrete Fourier Transform
MU-MIMO	Multuser Multiple Input Multiple Output
CDI	Channel Distribution Information
MACs	Multiple-Access Channels
BCs	Broadcast Channels
DPC	Dirty Paper Coding
MSE	Mean Square Error
SVD	Singular Value Decomposition
DFE	Decision Feedback Equalization
SLNR	Signal to Leakage and Noise Ratio
SINR	Signal to Interference Plus Noise Ratio
CCI	Co Channel Interference
DOF	Degrees of Freedom
SDMA	Spatial Division Multiple Access
3GPP	Third Generation Partnership Project
LTE	Long Term Evolution
HIPERLAN	High Performance Radio Local Area Network
LTE-A	Long Term Evolution -Advanced
SFBC	Space Frequency Block Codes
LOS	Line of Sight
QOS	Quality of Service
WMANs	Wireless Metropolitan Area Networks
SDM	Space Division Multiplexing
MMSE	Minimum Mean Square Error
QAM	Quadrature Amplitude Modulation
FEC	Forward Error Correction
GAs	Genetic Algorithms
HPAs	High Power Amplifiers

SER	Symbol Error Rate
TDD	Time Division Duplexing
FDD	Frequency Division Duplexing
MAC	Medium Access Control
MR	Maximum Ratio
RF	Radio Frequency
A/D	Analog to Digital
R-S	Reed Solomon
GF	Galois Field
MRT	Maximum ratio transmission
MRC	Maximum Ratio Combining
PZF	Phased Zero Forcing

CHAPTER 1

INTRODUCTION

In wireless communication, the demand of high throughput and data rate is an ever-growing aspect. Therefore, to satisfy these demands in accordance with the necessity of generations evolved with time, various technologies are introduced. This chapter provides the brief introduction to all the concepts that are associated with the context of multiple antennas and the assorted approaches such as Orthogonal Frequency Division Multiplexing (OFDM), Forward Error Correction (FEC) Codes and beamforming schemes that are related to its improvement for future wireless communication.

1.1 Multiple Input and Multiple Output (MIMO) System

Multiple Input and Multiple Output (MIMO) systems are considered one of the most significant invention in wireless communication which uses multiple antennas at source and destination for communication [1]. The availability of these multiple antennas at both the ends of the system is used for the optimization of the spectral efficiency and minimizing the errors. Primarily, MIMO takes the benefit of multipath propagation, as in this case each signal transmitted from antenna have multiple replicas. Due to these replicas each antenna at receiver side, receives a linear combination of these numerous data-streams. These diverse data-streams are divided at receiver with the use of various equalizers and algorithms obtained with the aid of Channel State Information (CSI). Therefore, the availability of multiple antennas at transmitter and receiver side in MIMO systems is used to acquire spatial diversity and multiplexing gain for the system [2].

In case of Spatial Diversity, same data-stream is transmitted over multiple antennas to improve the system reliability. Due to the transmission from distinct antennas, each sent data-stream have to pass through independent fading channels. So, the ratio of fading experience by each stream will be unique, therefore the probability of all data streams getting faded simultaneously reduces. So, at receiver side, out of these received streams there must be at least one data stream which experiences least fading than the rest, resulting into a reliable system [2].

Further, to characterize the diversity scheme of a system two distinct gains are introduced i.e. array gain and diversity gain.

Array gain which is denoted as ' g_a ' is defined as a ratio of average output Signal to Noise Ratio (SNR) ' ρ_{out} ' which is particularly measured at the input of receiver to average SNR ' ρ ' of the single stream. It basically measures the increment in ρ_{out} in proportion to the ρ [3].

$$g_a = \frac{\rho_{out}}{\rho} \quad (1.1)$$

Diversity gain which is denoted as ' g_d ' measures the increase in gradient of the error rate with respect to SNR. It is defined as the negative gradient for the plot, that is plotted between log of average error probability ' \bar{P} ' and log of SNR ' ρ ' [3].

$$g_d(\rho) = -\frac{\log(\bar{P})}{\log(\rho)} \quad (1.2)$$

To acquire spatial multiplexing gain in MIMO systems, independent data is transmitted over multiple antennas instead of transmitting same data-stream. Due to the transmission of multiple data at same time the spectral efficiency of the overall system increases without the assistance of extra power and bandwidth [2].

Further, in some cases despite the increases in number of antennas at transmitter and receiver side, the capacity of the system does not increase to a large extent as desired. This low rise in capacity is either due to band limit channels or due to multipath fading. So, to overcome this situation, space time coding is done in these systems. The principle function of all these coding streams is to increase the capacity and reliability of the system linearly without actually increasing the bandwidth. The various Space Time Codes (STCs) codes that are used in MIMO systems are Space Time Trellis Codes (STTCs), Bell Lab layered Space Time (BLAST), Space Time Block Codes (STBCs) and many others are there [1].

1.1.1 MIMO System Model

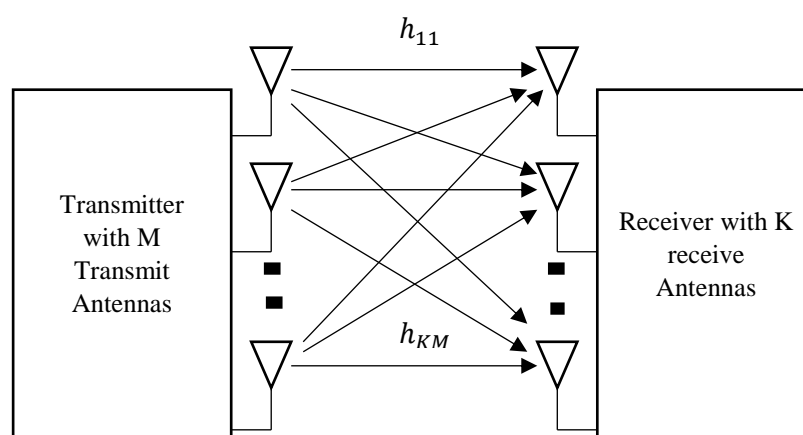

Figure 1.1 Point-to-Point MIMO System

Figure 1.1 depicts the point-to-point MIMO System having M transmit antennas and K receive antennas. To represent this system a discrete time model has been shown below consisting of matrix notations [2].

$$\begin{bmatrix} y_1 \\ y_2 \\ \vdots \\ y_K \end{bmatrix} = \begin{bmatrix} h_{11} & h_{12} & \dots & h_{1M} \\ h_{21} & h_{22} & \dots & h_{2M} \\ \vdots & \vdots & \ddots & \vdots \\ h_{K1} & h_{K2} & \dots & h_{KM} \end{bmatrix} \begin{bmatrix} x_1 \\ x_2 \\ \vdots \\ x_M \end{bmatrix} + \begin{bmatrix} n_1 \\ n_2 \\ \vdots \\ n_K \end{bmatrix} \quad (1.3)$$

Generally, this equation is written as [2],

$$Y = Hx + n \quad (1.4)$$

Where symbols y_1, y_2, \dots, y_K denotes the K dimensional vector of received symbols and symbols x_1, x_2, \dots, x_M denotes the M dimensional vector of transmitted symbols and symbols n_1, n_2, \dots, n_K denotes the K dimensional vector for the noise added at received antennas. In addition to this, each entry i.e. h_{ij} in the channel matrix H denotes the fading coefficient between i^{th} receiving antenna and j^{th} transmitting antenna [2].

In addition to the above described assets such as escalation in spectral efficiency, throughput and reliability of the overall system, there is also rise in the cost and complexity for the deployment of multiple antennas, especially in the case of small hand-held receiver units. As, it become a difficult task to install these multiple antennas in such small devices and simultaneously to provide power to all of them for transmission. So, the installation of this MIMO system leads to increment in the demand of space and power with the usage of extra antennas. Moreover, there is also increment in the system's signal processing because of the involvement of multidimensional signals. Further if the bandwidth of the channel provided by MIMO system is larger in comparison to the coherence bandwidth of the channel. Then the system has to go through Inter Symbol Interference (ISI) leading to the degradation in the overall throughput of the system unless it uses channel equalizer or some other technique for its elimination [2].

1.2 Orthogonal Frequency Division Multiplexing (OFDM) System

Orthogonal Frequency Division Multiplexing (OFDM) is a type of multicarrier modulation that uses orthogonal carriers for the simultaneous transmission of data. Primarily, this multicarrier scheme provides slightly greater bandwidth efficiency rather than other multicarrier schemes. As, in this scheme due to the orthogonality characteristic of the subcarriers, they can overlap each other without interference. Thus, they prevent the system from ICI without the requirement of any additional guard band [2]. Further, the prime usage of this OFDM technique is basically found in high data rate systems. In such systems with the implementation of OFDM scheme, they are shielded from the effect of ISI. For the instance of single carrier system, if there is escalation in the data rate then this will result into decrement in the duration of symbol period which will further get effected by the delay spread provided by the channel resulting into ISI. But if OFDM scheme is used then due to the division of the data in numerous parallel narrowband channels, its symbol duration is made to increase greater than the duration of delay spread of radio channel which avoids ISI [10]. In terms of frequency, this effect can be explained using the concept of bandwidth of sub streams. In this when the high rate data stream is slit into numerous low rate parallel data streams, then the bandwidth of these numerous sub streams becomes less than the coherence bandwidth of the channel preventing ISI in these individual carriers [11]. Due to such benefits provided with the usage of this OFDM technique, it has been used in numerous wireless standards and schemes such as IEEE 802.11a [12], High Performance Radio Local Area Network (HIPERLAN), Long Term Evolution (LTE), Long Term Evolution-Advanced (LTE-A) and many more [13].

1.2.1 OFDM System Model

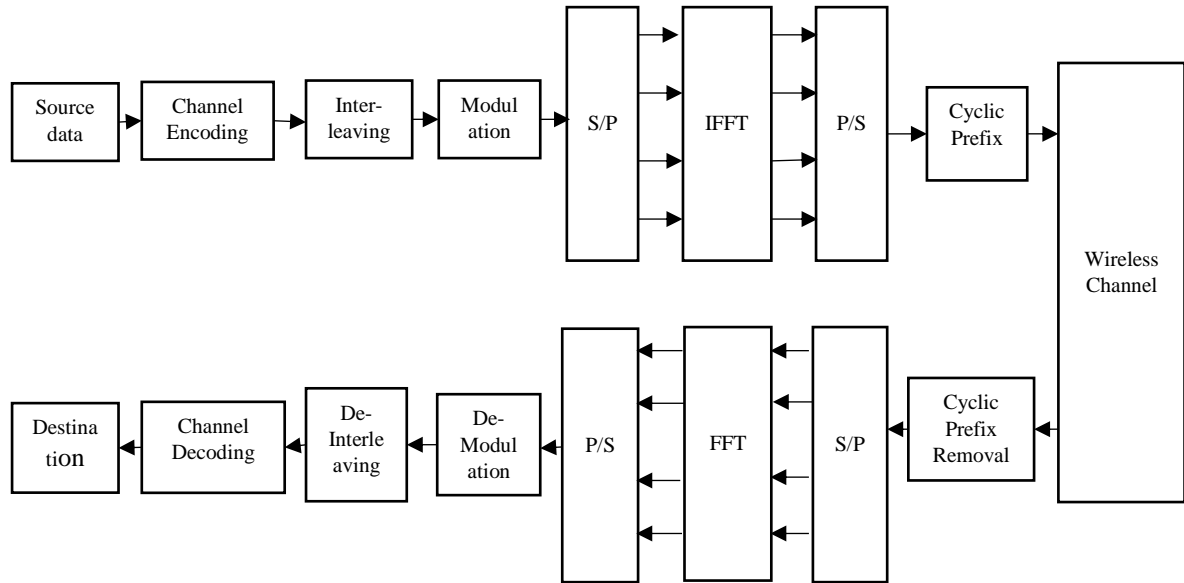

Figure 1.2 General Outline of OFDM System

Figure 1.2 shows the system model for OFDM System. This model represents both the transmitter and receiver side of the system consisting of various operations blocks that are applied on the transmitted data for its speedy and reliable reception at the destination [11].

1.2.2 Functionalities of Various Operational Blocks Used in OFDM System

1.2.2.1 Channel Encoding and Decoding

Due to the transmission of data in frequency selective channel using OFDM system, there is still chance of data suffering from the attenuation, resulting into errors in bits. So, to avoid such errors for reliable transmission of data, the data is spread out over the bandwidth using adequate coding approach. But using coding for transmission of data diminishes the effective throughput of the system. At the receiver side channel decoding operation is performed for receiving the actual information [11].

1.2.2.2 Interleaving and De-interleaving

In this operation the data for transmission on numerous subcarriers is arranged in such a manner that they are interlinked with one another. So, if on the way to the receiver there is some loss in data in one subcarrier due to frequency selective nature of channel, then it can be re-generated at the receiver with the assistance of remaining subcarriers using de-interleave operation [11].

1.2.2.3 Serial to Parallel Converter(S/P) or Parallel to Serial Converter(P/S)

These converters are used at the transmitter and receiver side respectively for converting the data into required form. At transmitter side, S/P converter is basically used for providing input to N-point IFFT block and at receiver side P/S converter is used for converting output from N-point FFT into serial form [11].

1.2.2.4 Inverse Fast Fourier Transform (IFFT) and Fast Fourier Transform (FFT) operations

These operations are used in OFDM scheme in place of conventional banks of sinusoidal generators and demodulators that are basically utilized in other multicarrier approaches. The use of conventional bank of modulators and demodulators increases the complexity of the system especially for the cases when a greater number of subcarriers is required. So, to overcome the problem of complexity and improved synchronization in the system N point Inverse Discrete Fourier Transform (IDFT) and Discrete Fourier Transform (DFT) operations are used at transmitter and receiver side respectively. Moreover, if the 'N' in IDFT/DFT operation is an integer which is equivalent to power of 2, then in place of IDFT/DFT operations more efficacious algorithms i.e. IFFT/FFT can be utilized. These algorithms are known for fast computation and can be interchangeable with each other until their duals are utilized on the other side. But in ordinary OFDM systems the IFFT operation is applied at transmitter side for conversion of signal in frequency domain to time domain and vice versa operation is performed at receiver side by FFT block [11].

1.2.2.5 Cyclic Prefix

It is a guard interval which is added as a prefix to OFDM symbol, such that its length surpasses the length of maximal glut of delay spread induced by multipath effect of channel in order to prevent the system from the effect of ISI. Basically, with the addition of cyclic prefix all the replicas of current symbol produced due to multipath propagation will reach the receiver before the start of the actual data part of the symbol. So, this guard interval part will be rejected at the receiver side ahead of the final accomplishment of the data [11].

Although the addition of cyclic prefix prevents the system from ISI, but at same time this adds to the redundancy part of the symbol and leads to wastage of efficacious transmit power. Further, in OFDM systems most of the errors are generated due to the effect of synchronization in FFT blocks. For instance, in case of timing offset occurring at the receiver side in FFT block results into gradual phase shifts in signal constellations. Primarily, this effect of signal constellation is more severe for the furthest subcarrier as this effect of phase rotation raise linearly in the direction of spectrum ends. Another synchronization error is due to frequency offsets which particularly induced due to discrepancy in the frequencies of local oscillators at source and destination resulting into Inter Carrier Interference (ICI) [11]. In addition to these effects, the one of the most deleterious aspect of OFDM system is Peak-to-Average Power Ratio (PAPR) increases with increment in number of subcarriers. This problem arises mainly with the addition of various subcarriers to each other at the time of IFFT operation resulting into high peaks. So, to enhance the performance of OFDM system there is need to resolve the problem of PAPR using some appropriate algorithms such as amplitude clipping, clipping and filtering, partial time sequence, selective mapping and many others [19].

1.3 Multiuser Multiple Input Multiple Output (MU-MIMO) System

This system couples the benefits of MIMO technology with Spatial Division Multiple Access (SDMA) technique [21]. It is primarily introduced so that data can be transmitted simultaneously to multiple users leading to increment in throughput and efficiency of the system. In these systems the assets of multiple number of antennas i.e. extra Degrees of Freedom (DOF) are primarily utilized to organize spatial separation between the various users along with increment in link diversity whereas in SU-MIMO approach it is utilized in the form of escalation in spatial multiplexing and reliability for single user. With the invention of these systems the number of drawbacks of the SU-MIMO systems have been surmounted. In these systems, the effect of increment in number of antennas at the transmitter site especially in Broadcast Channels (BCs) channels can be evaluated directly with increase in capacity of the system. Further these MU-MIMO systems are found to be more resistant to increase in channel correlation due to the usage of various user scheduling schemes and also to the Line of Sight (LOS) link which causes huge degradation of the system's performance in SU-MIMO systems. In contrast to SU-MIMO systems these systems required different transmission schemes for transmission of data in Multiple-Access Channels (MACs) and BCs channel [22]. But evaluation and analytical measurement of the uplink system i.e. MAC is comparatively easy in comparison to the downlink case (BC). As, in case of uplink systems most of the schemes required for its analyzation is similar to that of point-to-point MIMO system. Because in these systems the data transmitted by all active user terminals is send to the base station, due to this it becomes quite simple task for the base station to separate the data of multiple users due to availability of channel information and there is no such existence of multiple user interference for this case [23]. Further this system does not always require to have multiple antennas at the user terminals. It can even work equally well even in the presence of single antenna. But this constraint in the usage of antennas at receiver site leads to reduction in mobility of the system, as availability of extra antennas leads to increase in data rate and reliability for the system [22]. Further for the enhancement of the data rate in the uplink system various algorithms have been developed and implemented by the researchers. These algorithms worked basically on reducing the Mean Square Error (MSE) and boosting the sum rate capacity for the overall system. For the purpose of finding optimum transmission strategies in MACs first the relationship between the total count of symbols that are to be sent by each user and system performance is investigated. Then depending upon the results obtained, the discussion is taken whether each user would transmit single or multiple symbols. In this way the whole process of uplink transmission works [24]. Whereas in instance of downlink channels first with the aid of some precoding scheme the BC channel is break down into numerous numbers of parallel user links, such that each link is independent from other. Moreover, each new user link has the same potential and characteristics as of the channels in point-to-point MIMO approach and all the techniques such as BLAST, Singular Value Decomposition (SVD) and many more which are applicable to SU-MIMO channels could also be applied to these parallel BCs [26]. But in practical situation it is generally more difficult to implement downlink channel as for this system at receiver side there is no such information present which can be able to reduce the Co Channel Interference (CCI), therefore in this

type of transmission pre-interference elimination techniques are enforced. Further, these precoding schemes at the base station could be linear or non-linear ones depending upon the requirement of the system. Also, with the usage of linear schemes in precoders there is reduction in the computational complexity and cost of the system but these schemes are not able to reach the sum capacity which is actually achieved by Dirty Paper Coding (DPC). However, in case of DPC or nonlinear schemes although these achieves much better results in comparison to linear ones both in terms of capacity and throughput but their complex implementation hinders their overall performance [21]. In addition to this, along with precoding techniques, there are other various algorithms and techniques such as pulse shaping, user scheduling and fairness schemes which leads to the optimum performance of the system [27]. Moreover, whether the case of uplink or downlink channel the CSI plays a significant role in deciding which type of precoders and decoders should be utilized in boosting up the system performance. In case of the perfect CSI situation, the linear and DPC schemes can be easily implemented for the reduction of multiuser inference at user ends even for the case when each user contains single antenna. But in case of incomplete knowledge about the channel information, at transmitter site, then for this condition in order to remove interference at user ends the number of antennas for each user is raised. As, these extra antennas at the site would account for loss in multiplexing gain of the system. In addition to this solution for the case of partial CSI, there are also an alternative path in which instead of these conventional precoding schemes new quantization algorithms are applied and still more research is going on in developing such schemes which can work perfectly in the condition of partial CSI knowledge [22]. Due to availability of such functionalities these systems are used in numerous wireless standards such as IEEE 802.16m, Third Generation Partnership Project (3GPP) and enacts a major role in in transition of wireless communication from third generation technology to fourth generation technology [30].

1.3.1 MU-MIMO System Model

Figure 1.3 represents the block diagram of MU-MIMO system. In this diagram, the base station site has been shown consisting of M number of service antennas and single receive antennas at K user ends. Further, with this application of system to work even in the presence of single antenna has reduced the size of user devices to a great amount in comparison to point-to-point MIMO systems. Therefore, these systems can be easily indexed into small size hand held devices. As, discussed above in the downlink case before transmission of user data-streams, it is to be processed using some particular precoding technique which is here depicted using precoder block along with the channel information for the removal of inter-user interference at the user ends. Further, for boosting up the security and improvement in Bit Error Rate (BER) the system can also be encoded with various error codes [21].

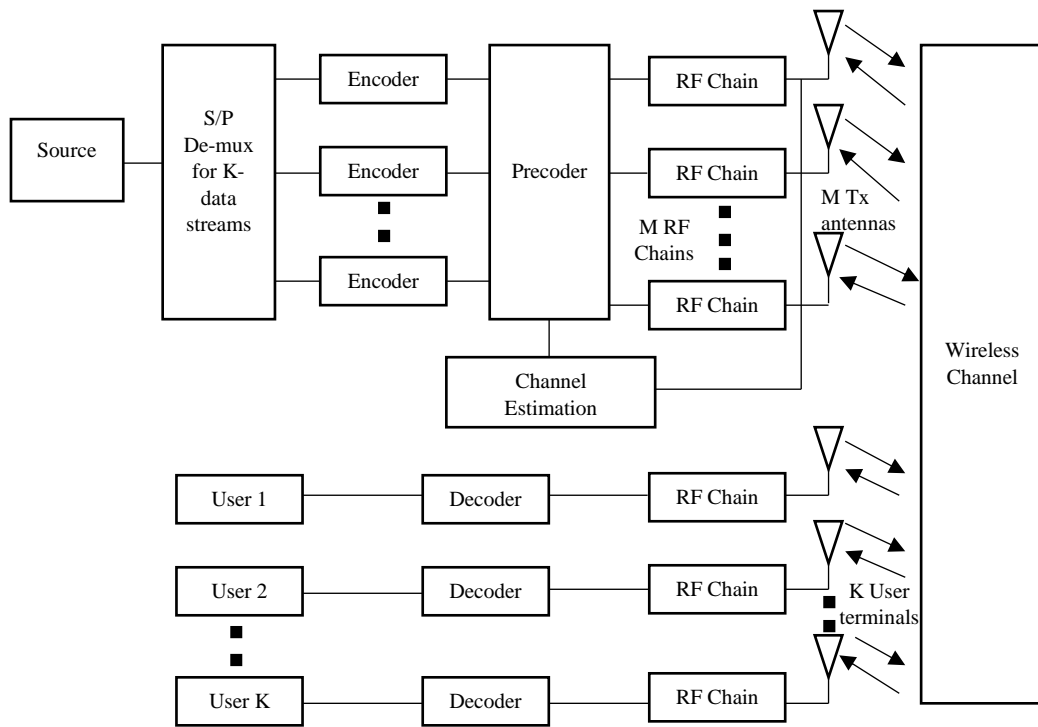

Figure 1.3 Block Diagram of MU-MIMO System

Although this system provides lot of advantages over conventional MIMO system, but in this system if the bandwidth of each independent parallel channel exceeds the coherence bandwidth then there could be a chance of occurrence of ISI in the symbols. So, to avoid this, it should must be combined with OFDM system which easily surmounts this effect of rise in ISI. Further, one of the most unfavourable effect about MU-MIMO is that it can serve only few devices at a given time. This restriction in the number of user devices that can be connected at a given time hinders its performance for the near future use [30]. Further, for the efficient implementation and usage of this system, it requires research in various areas such as its effects on higher layers, physical layers, optimum scheduling and power allocation algorithms [31].

1.4 MIMO-OFDM System

The coalition of MIMO system with OFDM technique has proven to be boon for the wireless systems. As, these systems are primarily known for providing high data rates especially under high Quality of Service (QOS) without increasing the use of spectrum [31]. So, the main reason behind the combination of OFDM system with MIMO technology is the elimination of ISI which is introduced in MIMO systems under frequency selective channel. Therefore, to overcome this interference with an effective and less complex technique in comparison to conventional equalizers the OFDM scheme has been combined with the MIMO technologies. In such systems, with the usage of multicarrier technique, the wideband channel gets converted into narrowband multiple channels due to which the bandwidth of the system becomes less than the coherence bandwidth and results into numerous flat fading channels [2]. Further, it has been found that this combine version of both the techniques inherit the benefits of both

conventional systems along with the new combine effects. Such as in this system the basic property of MIMO technology i.e. Space Division Multiplexing (SDM) is enhanced further when it combined with the multiple subcarriers and results into a robust system which can withstand in any channel impairments [32]. Therefore, it results into an effective system that fully exploits all the three dimensions i.e. space, time and frequency [2]. Due to existence of such assets these systems are also used in various extension of the wireless LAN systems and also in numerous wireless standards such as Wireless Metropolitan Area Networks (WMANs) [31].

1.4.1 MIMO-OFDM System Model

Figure 1.4 represents the general outline model for point-to-point MIMO OFDM systems. The number of OFDM modulators and demodulators used in these systems depends upon the number of transmit and receive antennas. So, in these SU-MIMO systems one of the main requirements in efficient working of the system is channel information at the receiver site which has been shown in the block diagram.

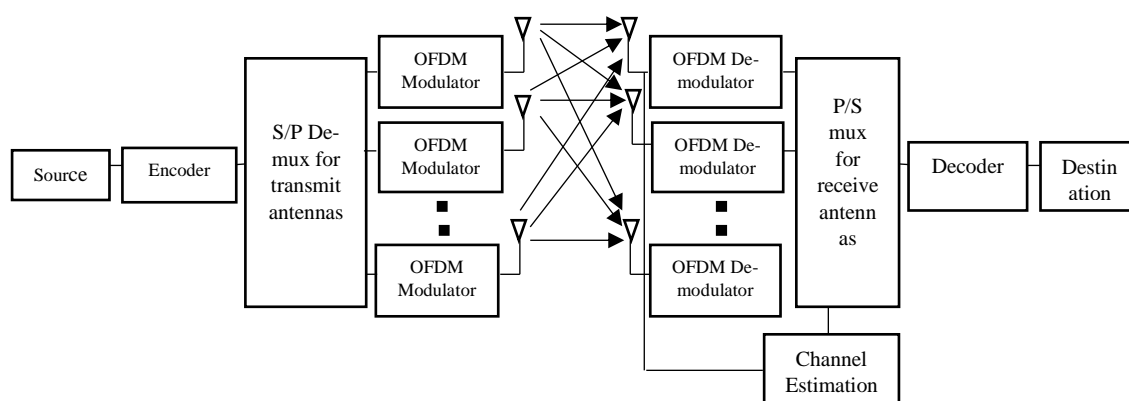

Figure 1.4 Basic Model of SU-MIMO OFDM System

As CSI information plays a significant role in assisting the system to detect data and maintains synchronization in the system. But to acquire this CSI, the system requires optimum training designs and algorithms otherwise this would affect the system mobility and leads to increase in computational complexity [34]. Further, in realistic environments it is not possible to acquire perfect CSI. So, the researchers are focusing on the techniques that could work even in the conditions of partial CSI and still resulting into desired data rates under the constraints of fixed error rate and transmission power [35]. Another important challenge which is faced in the implementation of MIMO-OFDM system is the synchronization of frequency and time offsets. This synchronization is a prime important aspect required basically in the OFDM systems as their mismatch would result into various offsets that would further give rise to undesired phase shifts and ICI resulting into system's degradation [31].

1.4.2 MU-MIMO OFDM System

Further, to extend the use of conventional SU-MIMO OFDM systems to multiple users, the SDMA technique has been combined with these systems. This leads to further increment in throughput and efficiency of the overall system. But in these systems especially for the downlink case, special care of inter-user interference must be taken of as it could severely affect the system error rate. So, for avoiding such interference the precoding of user data is done at the transmitter site [37]. Figure 1.5 represents the MU-MIMO OFDM system with M transmit and K single antenna user ends.

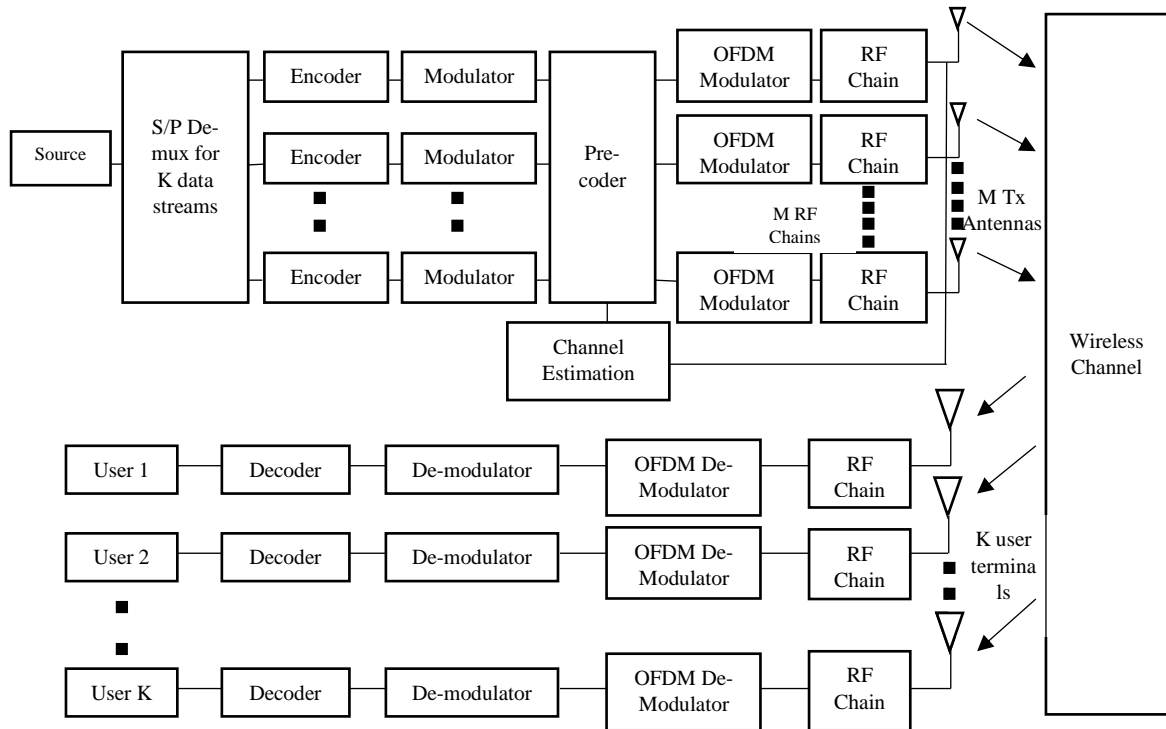

Figure 1.5 System Model of MU-MIMO OFDM

Further it has been found that for practical implementation of such systems numerous hardware challenges are to be solved. Such as the case of rank deficiency that leads to increment in number of users in comparison to receive antennas. Also, the usage of the conventional schemes of detecting multiple users in these MU MIMO-OFDM systems has been limited to the future wireless technology. Because such schemes performance is only constraint to small number of users and if the number of users increases beyond a certain limit their performance gets degraded. As, in case of maximum likelihood detection technique, which provides desirable performance only when number of users in the system are less and results into increase in complexity with exponential rates as number of users increases beyond a threshold limit. So, therefore many new adaptive algorithms based on genericity has been introduced in which the increase rate of complexity as a function of users is quite slow in comparison to the earlier ones [37]. Further, the effect of non-linearity provided by High Power Amplifiers (HPAs) at the transmitter site due to high PAPR also results into degradation of the system performance. Therefore, to optimize the system performance, efficient algorithms are need to search upon for reducing the effect of PAPR in the system [39].

1.5 Massive MIMO System

Massive MIMO systems are somewhat related to concept of MU-MIMO systems with some distinct features. As, in these systems the first main thing that separate these systems are the present of large number of service antennas in comparison to the user ends whereas in MU-MIMO case these antennas exist in almost equitable to each other and are small in number Therefore, with the usage of this large antenna array this system becomes scalable for achieving any desired degree and leads to provides huge increment in array and spatial multiplexing gain. Due to such large gains there is a large increment in effective throughput of the system and becomes a significant candidate in meeting the demands of the near future generation [40]. Particularly the extra DOF provided by the usage of excessive antennas at base station are responsible for focusing energy beams at the desired region, therefore leading to decrement in the required transmission power and providing effective energy efficiency [41]. Further it has been found out that in the instance of perfect CSI the transmission energy at each antenna of user ends decreased down by the factor equivalent to the number of service antennas and in case of imperfect CSI this decreased down factor becomes equivalent to square root of the total service antennas [42]. Also, for the implementation of this system it requires the use of low cost and low power components. With the usage of such components the load of precision, accuracy and linearity gets reduced on the system because it would become nearly impossible to manage the devices that are used in earlier MIMO technologies such as high gain amplifiers and Radio Frequency (RF) chains in such large numbers especially in terms of their maintenance and handling. So, particularly this massive MIMO system relies on the phenomenon of large number known as channel hardening for elimination of phase noise, impairments in hardware and channel fading [41]. But this channel hardening is only possible at the transceiver site of base station not at the transceivers of user equipment which could affect the system performance [43]. In addition to this with the assistance of some algorithms and extra DOF it is possible to make this system resistance to intentional and unintentional jamming [41]. Further in these systems the complexity in signal processing doesn't rise with the increase in no of antennas as comparison to that of MU-MIMO approach. This is because these hyper MIMO systems only make use of linear processing techniques at their service antennas for precoding of the user data-streams. Particularly, the precoding of the streams is done to avoid inter-user interference at the user ends and due to this it become necessary only for the base station to know the channel information. This functionality reduces the size of handheld user devices and improve their performance [44].

1.5.1 Types of Massive MIMO Systems

Based on the usage of different frequency bands, this Massive MIMO has been divided into two categories

1.5.1.1 *Massive MIMO for sub 6GHz*

1.5.1.2 *Massive MIMO for mm Wave*

1.5.1.1 Massive MIMO for sub 6GHz

The massive MIMO technology in this band basically works on improving the throughput of the current spectrum band and provides efficient spectral and energy efficiency in existence of other wireless standards and techniques. Due to the presence of inverse relationship of time and frequency, the pathloss and coherent time of channel is more suitable of this band which further assists the system in covering more range and serving large number of user ends. Also, this system is known for providing relatively more user mobility in comparison to the other mm-wave band system [44].

1.5.1.2 Massive MIMO for mm Wave

In this massive MIMO technology there is exploitation of new frequency band between 6GHz and 100GHz and is responsible for providing new assets and challenges to the system. Particularly, the problems such as scattering, non-line of sight (NLOS), atmospheric absorption and many more are easily resolved in this band. In addition to this, the system in this band can provide large link capacity but this benefit is only limited for the few users which are at short range to the base station due to severe path loss and increment in the noise power particularly at high frequencies. This all aspects results in the severe degradation in the overall user mobility. So, a lot of research has been going on for the development of the massive MIMO technologies in this frequency band [44].

Another important fact about the Massive MIMO technique of sub 6GHz is that this system could only work in the Time Division Duplexing (TDD) mode due to the presence of channel reciprocity property. Due to such property it becomes especially easier for the system working in downlink mode to access the channel information from the uplink pilots which only depends upon the number of antennas at user terminals not on the number of service antennas at the base station. Therefore, by applying reciprocity property the downlink channel is estimated at the transceiver of base station for effective transmission. But actually, to calibrate this reciprocity from the hardware chains is slightly difficult because these transceivers at the user end and base station are not actually designed to work in this mode. Therefore, with the assistance of some additional algorithms this problem can be easily rectified [41]. Also, many researches are going on to find the possibility of this system to work in Frequency Division Duplexing (FDD) mode which could further add on to increase in mobility of the system. But still the solution to find out the channel estimation for these systems is a big problem which makes this system to only realise in case of low mobility scenarios. In some researches it has been found out that in mm wave band the channel sparsity could play a significant role for the effective implementation of this system in FDD mode [44]. The other important issue in this system is the selection of appropriate number of users which could lead to the achievement of the optimal spectral efficiency. So, this selection process of scheduled users depends upon the various parameters such as number of antennas, impairments existing in hardware components, channel coherence time, precoding schemes, pilots and many others. So, depending upon all such factors in the system, the scheduled users are chosen [46]. Further, the problem of pilot contamination in these systems could result into limiting the performance of the system. So appropriate algorithms must be required for choosing the pilots required to be reused [41]. In

addition to this the other challenges arose with these systems are the management of the low power components to work effectively and in synchronization, reduction in the usage of power by internal components and finding new deployment scenarios for its practical implementation [41].

1.5.2 Massive MIMO-OFDM System

This system has been formed by the combination of two major technologies i.e. massive MIMO and OFDM modulation and has found to be performed several times better in comparison to the earlier MIMO-OFDM coalitions due to the usage of high dimensional MIMO systems which provides channel hardening and discards the use of frequency domain scheduling in getting multiple access. Therefore, each subcarrier in OFDM system would have access to the equivalent channel gain and provides the access of complete bandwidth to each terminal. With this application of this system the redundancy involves in accessing and controlling the signal in a given frequency band is almost discarded. So, this system assists in reducing the complexity of the Medium Access Control (MAC) layer [41].

Further, for the practical implementation of the hyper MIMO system the usage of OFDM technique plays a key role in elimination of ISI especially in the presence of frequency selective channels. But for the proper working of this effective combination there is being requirement of channel estimation which has been achieved using pilots in the system in TDD mode. But the availability of orthogonal pilots is comparatively less than required. Therefore, to full fill that demand non-orthogonal pilots are used which could further lead to the problem of severe pilot contamination in these systems. So, to solve that problem the researchers have introduced the concept of phase shift pilots which results in increment in system overhead. This overhead problems in estimating the channel has been further resolved with the introduction of adjustable phase shift pilots. This new technique has been shown performing equally well as conventional ones with reduced overhead [46].

Another inherited problem of this MIMO-OFDM system is high PAPR. This problem in convention MIMO technologies has been easily resolved with the usage of a smaller number of linear RF components but in case of hyper MIMO due to use such large number of expensive linear components becomes a challenging task. Therefore, to avoid the researchers have introduced various algorithms such as PMP that provides quite better performance than these linear expensive components and also could be easily implanted in the earlier deployed systems [47].

1.5.3 Beamforming/ Precoding in Massive MIMO Systems

Beamforming and precoding represent almost the same functionality of directing the transmitted signals in their required and appropriate directions. Depending upon the design and technology, these schemes are used for transmission of signal from numerous antennas at the transmitter site to multiple or single user ends. In these schemes the main aim of the system is to focus the signal energy at the desired user and minimize its leakage at the other ones. The multiple antennas used at the transmitter sites transmit same signal with different phases and amplitudes towards the users. So, for the purpose of increasing strength at the given user, deliberately all the signals from these multiple transmit antennas are added

coherently which provides the user with required signal power and at the non-intended user these different signals are added destructively resulting into weak signal strength for avoiding inter-user interference. This constructive and destructive interference of signals can be represented mathematically by the products of beamforming vectors which includes amplitude and phases of the multiple signals. In relation to this context, the constructive addition of signals at the desired user could be explained by considering large inner products of these vectors and the destructive addition with smaller inner products. Further, these beamforming schemes can be implemented in both LOS and non-LOS scenarios. Figure 1.6 represents the beamforming in LOS scenarios which shows the high beam in direction of the desired user and side lobes to the non-intended users. These side lobes are mainly responsible for the cause of undesired interference. In instance of non-LOS user, the beamforming is achieved using addition and subtraction of multipath components. Further due to the extra DOF provided by the massive MIMO system, it focuses high beams of energy at the desired places and provides energy efficiency in the system. This functionality of this system leads to provide SDMA to multiple users. Due to this the multiple users could be served at the same time [48].

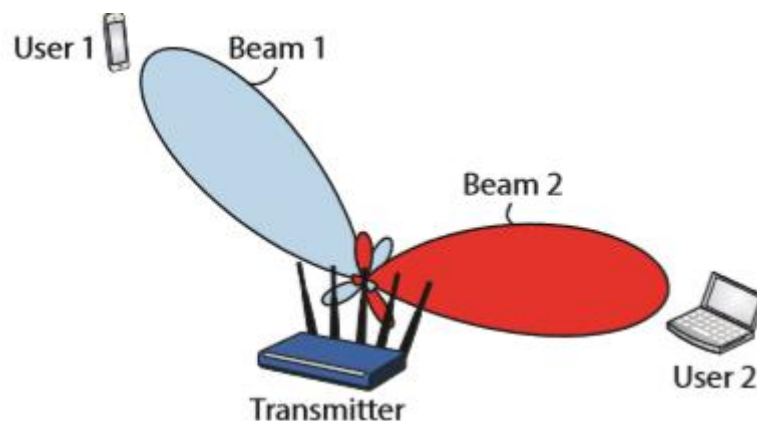

Figure 1.6 Beamforming in LOS Scenarios

In instance of hyper MIMO systems, the precoding techniques used are mostly linear ones. Because the use of non-linear schemes such as DPC would lead to increment in the system complexity if it is applied for such large number of antennas. Although if comparison has been made between these linear and non-linear schemes, then in terms of capacity achieved the non-linear approach outperforms the linear ones. But in case of massive MIMO systems due to channel hardening and extra DOF these linear schemes are appropriate to use because the computational complexity involved in these is quite less [40]. Also, the use of these precoding techniques is also dependent on the design of the system used. Therefore, different types of precoding schemes are applied for the multicell and single cell scenarios [49].

1.5.4 Hybrid Beamforming in Massive MIMO Systems

This hybrid beamforming can be applied for both sub 6GHz massive MIMO systems [50-51] as well as also to mm-wave massive MIMO systems [51-53]. The main aim behind the introduction of such scheme is the reduction in the usage of system hardware which could further leads to increment in cost

and system implementation complexity, if it has been used with large scale antenna systems. Particularly, in conventional beamforming schemes with each antenna at the base station, a RF chain has been used consisting of mixers, amplifiers and Digital to Analog (D/A) converters. Due to usage of such chain with each antenna give rise to cost and complexity related problems. Therefore, a hybrid beamforming scheme has been introduced for the MIMO technologies which reduce the usage of RF chain in the system. The main principle of this approach has been to achieve the same performance as achieved by fully digital beamforming scheme along with reduce hardware complexity [52]. So, to perform this various algorithm have been proposed by researchers depending upon the need and specifications required. But the basic design of all these techniques have remain same and it has been formed by the combination of low-dimensioned digital precoder along with full-dimensioned analog precoder. In these schemes with the usage of the low dimensional digital beamformer, all the processing of base band signal is performed at this precoder for reduction of the inter-user interference and only phase shifting process has been passed on the analog precoders of RF chains. These phase shifters at analog stage are cost effective due to which despite the usage of full dimensional analog precoder, the cost of the system doesn't gets raised [51]. So, according to the design using different precoding schemes, methods in obtaining CSI and analog processing various algorithms can be evolved for this hybrid approach. Further, with aid of simulations it has been evaluated that these hybrid schemes perform equally well as performed by the full dimensioned digital beamforming scheme. Also, its implementation has been verified for the practical scenarios where instead of infinite resolution phase shifters only finite phase shifters exists [52].

1.6 Forward Error Correction (FEC) Codes

Forward Error Correction (FEC) codes are used in massive MIMO-OFDM Systems to improve the performance of system. With the usage of these codes the data-streams transmitted to multiple users becomes more reliable and results into decrement in the BER. These improved BER can further be used to reduce the size of small hand-held devices, with reduction in number of receive antennas per user in comparison to the un-coded ones. The main purpose of using these codes is to increase the capacity of the system by adding redundant information bits. This process of improving system capacity using these redundant bits is called as channel coding [54].

There are various types of FEC codes available. The model used in this work has been based on two of them.

1.6.1 Convolutional Coding

1.6.2 Reed Solomon Coding

1.6.1 Convolutional Coding

These encoding is comparatively difficult and are more complex than the block codes used. For coding these codes are dependent on the past inputs. The code is represented using the notation (n, k, m) where n represents the number of output bits from the encoder in per cycle time, k represents the number of

inputs bits and m represents the memory length of encoder. The two main parameters which provide whole of the information about the code are code rate and its constraint length. The code rate is represented using the ratio between k and n i.e. $\frac{k}{n}$ and the constraint length is depicted by K which represents the number of k bit stage to deliver to the given logic for the production of output symbols. To use the encoder of the system, initially it is brought to all zero-state. This further assist the system in encoding and decoding the codes. Further, there are various ways available in theory to represent these codes such as using tree, trellis or state diagram [55].

These codes are generally used in the communication system as channel codes. At the receiver side its decoding is achieved using Viterbi algorithm which is further divided into types i.e. hard and soft based on the quantization. This decoding algorithm has been used as it is quite beneficial for hardware implementation and provides a steady decoding time. But the complexity of this keeps on increasing with respect to constraint length of system. In relation to the context of the work only hard decoding algorithm has been used which is based on the concept of maximum likelihood estimation for selecting the transmitted code from the received one and on the trellis diagram for analysing path metrics [55].

1.6.2 Reed Solomon (R-S) Coding

Reed Solomon (R-S) codes can play a significant role in reducing BER when used as channel codes. These codes basically belong to the category of block codes in which the message signal is divided into fixed length blocks. These blocks are widely used in many practical systems such as in storage devices, mobile and satellite communication and also in modems. Particularly, these codes are generally known for correction and detection of burst errors in the data streams. These RS-codes work in the Galois Field (GF) which is made using the primitive polynomial. In this code the generator polynomial as well as code symbol lie in same field due to which there has been great reduction in the computational complexity of the system [56].

To represents the R-S codes (n, k, t) notation has been used. Here k depicts the number of symbols input to a block, n depicts the number of symbols output from a single block and t depicts the number of total symbol errors that can be corrected in the received coded stream. Here code rate is depicted by the formula $\frac{k}{n}$ and total length of parity symbols added in a block is $n - k = 2t$ where $2t$ depicts the total number of errors in a block that can be only detected and out of this only t can be corrected as well as detected. Therefore, when a coded block is decoded, if its errors symbols are less than t than whole of original message will be recovered but if its errors symbols are greater than t then this code would not be able to guarantee the reception of original data without errors [56].

Also, $n = 2^m - 1$ where m represents the number of bits per symbol used in a block. So, here when a R-S coded scheme has been implemented it is always bounded by a code GF (2^m) [56].

In the decoding process of R-S codes a general scheme has been followed in which first the syndrome in the code is been computed. After that using the various algorithms such as Berlekamp-Massey or Euclid's approach the location of the symbol error is being determined by first finding the polynomial

which can assist in locating the error then using Chien search scheme its root have been evaluated. Further the calculation of the values of the symbol error is done mostly by generally used Forney approach. Then using modulo-2 operation the values of the determined errors are added to received signal at their locations for retrieving the original signal [56].

1.7 Framework of Thesis

The whole work of thesis is organized into five chapters.

Chapter 1: This chapter discussed the basic details and concepts related to the MIMO systems and their advancements in combination with other technologies such as OFDM, beamforming schemes and FEC. So, that the working of these techniques in sync, advent such systems that can withstand in any channel impairments.

Chapter2: In the second chapter the literature overview of the papers related to the concept discussed in chapter 1 is presented. In addition to this, it also analysis the gaps that appeared during the research along with the brief outline regarding the objectives and methodology of the thesis work.

Chapter 3: The discussion of all the system models that are utilized in the work and the related mathematical equations has been made in this chapter. Primarily it provides the detailed study of three main systems. These are the system which are designed for broadcast and MAC transmissions using linear and hybrid beamforming schemes.

Chapter 4: This chapter presents the results that are derived from the implementation of above discussed system. Primarily, this chapter is segmented into two main parts. The first part provides the comparison of the various MIMO-OFDM technologies based on the BER and achievability rate performance of the systems. In the second part the comparison is made for MU Massive MIMO-OFDM system, depending upon the beamforming schemes used in the precoding process of broadcast transmission.

Chapter 5: This chapter provides the conclusion and discussions related to the future aspects that can further enhance the system performance.

CHAPTER 2

LITERATURE SURVEY

This section overviews the work done by the various researchers regarding the MIMO systems and its related modified technologies such as MU-MIMO and Massive MIMO along with combination of OFDM techniques and their associated parameters:

2.1 MIMO System

S.M. Alamouti [4] has proposed a two-branch diversity scheme at the transmitter side which yields same diversity order as provided by Maximum-Ratio Receiver Combining (MRRC) scheme consisting of one transmit antenna along with two antennas at receiver side. These antennas at transmitter side does not required any kind of feedback from the receiver part and has same computational complexity as in case of MRRC. Primarily this scheme has been developed to reduce the complexity at receiver terminal which mainly consists of small remote units. Further, it has been shown that this proposed scheme can also be generalized to two transmit antennas and M receive antennas, which increased the diversity order of the system to $2M$. But in this scheme, the requirement of radiated power and pilot symbols for the estimation of channel increases to double in comparison to MRRC scheme. As, this scheme requires the transmission of two distinct symbols simultaneously from the two transmit antennas.

Arogyaswami J. Paulraj *et al.* [5] have presented a brief analysis on MIMO technology including its channel models, transceiver design, performance limits, capacity and coding. In this, the authors have presented the importance of MIMO systems in making 1Gb/s data rate in reality in wireless communication for Non-Line of Sight (NLOS) scenarios whereas for achieving the same with Single Input Single Output (SISO) system in NLOS condition, the assumption of non-fading channel along with 10^9 product of spectral efficiency and bandwidth has to be considered.

R.Xu *et al.* [6] have discussed the MIMO system performance in presence of Rayleigh and Rice channel models using the Zero Forcing (ZF) technique at the receiver. From the analytical derived and simulated results, it has been observed that the performance of MIMO system degrades in case of Rice fading model in comparison to the Rayleigh channel model. It has been also found that this degradation associated with SNR increases as Rician K factor increases. Moreover, the authors have also evaluated the performance of the MIMO system in case of correlated matrix and have analysed that, the system performance degrades with increase in correlation of the matrix.

Chen Wang *et al.* [7] have evaluated the performance of MIMO system with ZF technique in presence of inaccurate channel information for uncorrelated flat fading Rayleigh channel model. In this paper initially, the authors have discussed the significance of MIMO technology intensifying the capacity of system without the aid of additional bandwidth and power. Further, the authors have derived the close form approximations for the post processing SNR and BER. For this case they have considered the

channel estimation error as complex random variable having gaussian distribution along with M-PSK and M-ary Quadrature Amplitude Modulation (M-QAM) modulation schemes. From these approximations the authors have evaluated that in case of system having channel estimation error 'e', the BER function of the system relies on the number of antennas at transmitter and its performance gets degrade with the escalation in number of antennas for same value of e and D where $D = N_R - N_T$. In addition to this, it is also found that as in case of normal condition the BER approaches zero with increment in SNR but for this error case it approaches to some error floor which further depends upon e, N_T and N_R .

Enzo Baccarelli *et al.* [8] have discussed the pilot-based MIMO system assuming that the system consists of inexact channel information at receiver along with feedback path from receiver to transmitter for the purpose of communication. Moreover, this given system is also assumed to be subjected to the interim radiation power constraints. Primarily, the authors in this work have concentrated on the evaluation of enhanced power allotment, throughput and outage probability. So, for the intent of assessment of throughput for the system, the input signals based on gaussian distribution have been analysed. From this analyzation, the conditions to accomplish the Shannon capacity are proposed. Based on the evaluation of above described system for the instance of perfect feedback path the authors have built up the analytic expression for the calculation of ergodic throughput of the system. Also, for the case of optimized allotment of power to the transmit antennas in the condition of imperfect channel information at receiver side, an iterative algorithm has been proposed. So, after the evaluation of the system in perfect feedback condition, in the last segment the above proposed algorithm for power allocation is checked for the case of imperfect feedback and its effect on the loss of system throughput is measured. In addition to this, in this work the authors have also developed the upper and lower bounds expression for case of outage evaluation.

Chen-Nee Chuah *et al.* [9] have presented the significance of Multiple-Element Arrays (MEAs) in increasing the system capacity in comparison to single antenna systems. Particularly, for the purpose of comparison they have evaluated the single user system consisting of dual antenna arrays in the presence of both correlated as well as independent fading channel. Primarily, the correlated fading channel with few assumptions in relation to the scaling of the structures of the correlation part has been used for the observation of the system performance in practical situations. In addition to this, in this work all the performance evaluations have been derived particularly for two scenarios i.e. for water filing algorithm and equal distribution of power algorithm and have found that the performance of former algorithm overlays the performance of other. From the above described system, the authors have derived the asymptotic capacity equation for n number of antennas and have evaluated that, the system capacity increases linearly with n number of antennas in both instances, but its increase rate is 10-20% less for the case of correlation channel. As in correlation fading, it has been observed that the increase rate of capacity decreases with increase in SNR and for the instance of mutual information although the

increase rate increases at all SNR but its rate is comparatively slower than the case of independent fading.

2.2 OFDM System

Taewon Hwang *et al.* [10] have presented an extensive analysis on OFDM and its associated impairments. In this work the author has mainly highlighted the role of OFDM in eliminating ISI which is primarily generated in single carrier transmission due to escalation in data rate which results in reduction of symbol duration. So, to overcome its effect, the symbol duration is made larger than the delay spread of channel as in case of OFDM system. In this system the whole channel is partitioned into number of subchannels on which simultaneously transmission of data occurs that results in increment in data rate and reduction in ISI. Due to such functionality of this technique, its usage has been increased in numerous wireless standards and systems. Further, the authors in this work have also provided a brief discussion on the various functionalities and techniques for the reduction and measurement of numerous parameters such as frequency and time offsets, measurement of channel, PAPR and many more affiliated to OFDM. In addition to this, in the last segment of this paper the authors have introduced the role of MIMO systems in increasing capacity, but these systems could work efficiently only in flat fading channels. Therefore, to use this technology in case of broadband frequency selective channel it is combined with OFDM. So, due to the increase in throughput and efficiency of overall system with the combination of MIMO-OFDM approach, its usage has been increased in enormous wireless standards and technologies.

Steve Kapp [12] has provided the detailed description on wireless standard of third generation i.e. IEEE 802.11a. This standard has been come into existence before IEEE 802.11b. But its practical usage has been deferred due to complexity involved in its implementation. So, with the passage of time there has been great progress in technology which solved the complexity problem with the ease in cost and efficiency. Further, in this work the author has provided comparison of this standard with that of IEEE 802.11b and IEEE 802.11g and has presented their respective pros and cons. From these comparisons, it has been found that the invention of IEEE 802.11a standard have upraised the throughput of the wireless system from 11Mbps to 54Mbps. This great improvement in the efficiency has been because of OFDM modulation scheme used in this described standard. This technique reduces the channel distortion caused by fading and leads to improvement in overall throughput of the system due to the usage of multiple channels for transmitting data.

Louis Litwin [13] has discussed the significance of OFDM in the increment of system efficiency with the usage of orthogonal subcarriers. Further, the author in this work has described the handling of OFDM systems in various standards such as IEEE 802.11a and HIPERLAN/2 and also, in asymmetric Digital Subscriber Line (DSL). The long length of data symbol increases its resistance against fast fading conditions and noise generated by impulse, thus aiding the system in avoiding distortion. Also, this technique provides the users to use distinct type of modulation schemes on various subcarriers known as dynamic bit-allocation. So, relying upon distinct noise levels, the various subcarriers could

choose among different modulation schemes, depending upon the increment in system's efficiency. In addition to this, the author has also laid its focus on the importance of using FFT which reduces the complexity in the implementation of hardware for multicarrier modulation technology especially for the instance of large value of subcarriers.

Paul H. Moose [14] has presented the role of frequency offsets in the increment of ICI in OFDM system. This introduction of ICI to system reduces the SNR for the DFT outputs. In this work, the author has shown and verified the maximum value of offset i.e. 4% or less than this is required for obtaining the signal to interference ratio greater than or equal to 20dB. In addition to this the author has also proposed an algorithm known as Maximum Likelihood Estimation (MLE) for the measurement and estimation of the value of frequency offset. This derived algorithm assists in the generation of accurate results as both intercarrier interference and signal energy support in estimation of offset value. Moreover, it has been also observed from the derived algorithm that the error in estimation is independent of fast fading and channel spreading and only relies on total energy of symbol for its measurement.

Thierry Pollet *et al.* [15] have evaluated the BER performance of OFDM system with M-PSK and M-QAM modulation schemes for Additive White Gaussian Noise (AWGN) channel. Primarily, in this work this BER is evaluated experimentally in the existence of both carrier frequency offset along with phase noise. From the observations of the experimental results, it has been evaluated that the performance of OFDM system deteriorates with increment in the value of frequency offset and phase noise. Further, on comparison of this OFDM system with single carrier, it has been found that this system is more sensitive to these impairments due to the increment in sensitivity with increase in number of subcarriers and longer duration of OFDM symbol. So, from the above derived comparisons it has been concluded that for a given detrition in BER performance for the same data rate, the value of offsets required in instance of OFDM systems must be smaller than that of single carrier systems.

Timothy M. Schmidl *et al.* [16] have proposed an approach to obtain synchronization in OFDM system particularly for the instance of channel suffering from frequency selective fading. Primarily this proposed method has been derived for the systems which required rugged and brisk operations. For such rigorous systems, one training sequence equivalent to two OFDM symbols has been transmitted once for the case of burst transmission or regular transmission. With the aid of such sequence, it becomes relatively easy to detect the start and end of the frame for the symbols. Also, this sequence provides pretty exact estimation for timing and frequency offsets. In addition to this, rather than providing exact value, it provides noticeably extensive range for the procurement of carrier offset and also assist the system in predicting the SNR value. Moreover, from various observations it has been found that the probability of losing this sequence is fairly less. Due to rapid and small overhead generation procedure involve for synchronization of offsets, this method has been useful for Wireless Local Area Network (WLAN) as there would be requirement of transmission of just one sequence over numerous numbers of OFDM symbols.

Jiho Jang *et al.* [17] have derived a method which boost up the data rate with the aid of power allocation scheme for multiple user OFDM especially for the instance of downlink channel. Initially in the case for multiuser OFDM, the data is broadcast simultaneously to multiple users with the aid of numerous orthogonal carriers. So, for the purpose of achieving maximal data rate usually, one subcarrier is mutually shared by several users. But for the case of transmit power allocation algorithm, this data rate escalation has been accomplished in certain different way. According to this algorithm, the exploitation of spectral and multiuser diversity of the system is done in two stages. In the first stage of subcarrier selection, it has been derived from this scheme that for the enhancement of data rate of the system each subcarrier must be empowered to only one user rather than to multiples. Further the second stage of this schemes involves the strategy of allocating power at transmission side. In accordance with the given scheme it has been found that for accomplishing maximal data rate water filling algorithm must be used for allocating power. But with the usage of this power policy, there has been increment in the computation complexity of the system. So, to solve this problem the derived algorithm used an easy method. In this method basically for each subcarrier involved, the users with finest subcarriers are chosen and then for these particular combinations of user and subcarriers the transmit power is divided equally among them. Moreover, it has been observed from the achieved results that the increment in data rate of this system is linearly related to number of users. Further, it has been also found that with this proposed scheme the increment in data rate overlays the performance of conventional Frequency Division Multiple Access (FDMA) systems. In addition to these observations, it has been evaluated from the obtained results that for the instance of large number of users involved the capacity obtained by this derived scheme is relatively higher than that for the case of AWGN channel.

Leonard J. Cimini *et al.* [18] have presented the role of OFDM in accomplishing the increment in data rates. But this enhancement in the capacity of system has been restricted by the PAPR of the system. This PAPR is an attribute of multicarrier schemes due to which the system endures from spread out in spectral and distortions in in-band if the signal is made to proceed from non-linear equipment. So, for the minimization of this PAPR the authors have discussed two basic techniques i.e. partial transmit sequence and selective mapping and have found that with the usage of these two methods although the PAPR is reduced with slight reduction in efficiency. But this decline in PAPR is achieved at the cost of increase in complexity of the system. Therefore, for accomplishing the devaluation in PAPR with reduced computational complexity, the authors have proposed a new scheme which integrates partial transmit sequences based on suboptimal methods. Further, the performance of this proposed scheme is also evaluated using simulations which verifies that this scheme assists in minimization of PAPR with very less deterioration in performance.

Seung Hee Han *et al.* [19] have provided the brief overview for the techniques which accomplish in declination in the effect of PAPR, primarily for the case of multicarrier systems such as Discrete Multitone (DMT) and OFDM. As, in these systems with the introduction of PAPR, all the assets achieved with the multi carrier communication is overshadow by the degeneracy caused by PAPR.

Basically, the authors in this work have discussed numerous PAPR declining techniques such as tone injection, interleaving, partial transmit sequence, clipping, filtering, selective mapping and many more. With the usage of such techniques although there is reduction in PAPR but this reduction is attained at the cost of accession in transmit power, complexity of system, BER and deprivation in data rate. In addition to this, the authors have also discussed some norms for choosing appropriate PAPR devaluation technique for the given system. They have also mentioned that in practical implementation of such multicarrier systems the influence of D/A converters, filters and amplifiers must be examined before choosing the PAPR minimizing scheme.

Tao Jiang *et al.* [20] have proposed a new method for the decrement in PAPR of the system. In this new approach rather than using μ -law companding technique, an exponential companding access has been proposed. In this scheme, rather than expanding signals with small amplitude values for the purpose of boosting up overall power of the system as in the instance of μ -law companding, all the signals whether having small or large amplitude values is regulated to achieve the system power at equal level for obtaining systematic distribution of output stream with the aid of transfer parameters. Further it has been evaluated from the simulated results that the declination in PAPR results in less side lobes in system's spectrum in comparison to the earlier used μ -law companding scheme. In addition to this, it has also been found from the resulted simulations that with the implementation of this new scheme there has been great reduction in the BER, phase error and PAPR for a given system in comparison with the earlier companding scheme.

2.3 Multiuser MIMO System

Quentin H. Spencer *et al.* [21] have provided a brief discussion on the capability of MIMO systems in fulfilling the requirements of the future generation. As, with the introduction of this technology there has been an enormous increment in throughput of the system in comparison to the conventional ones, basically this is due to increase in diversity gain and capacity of the system. Primarily, the authors in this work have introduced the concept of MU-MIMO system which is based on MIMO technique along with space division multiple accessing. With the usage of this scheme in practical scenarios, it provides access to multiple users at the same time along with all the assets that have been provided in conventional single user MIMO systems. So, this scheme increases the overall achievable rate of the system. Further, with the usage of this scheme to multiple users there could be possibility of inter-user interference which should be minimized using various algorithms. In this context, the authors have presented two types of algorithms especially for the downlink channel. In first algorithm linear approach has been used which is based on uncomplicated and economical signal processing schemes but using this algorithm, the system is unable to meet the achievable capacity rate of the system. In second algorithm, non-linear approach i.e. dirty paper coding has been applied to the system and have found that this scheme provides relatively better capacity gains than the former one but at the cost of increased computational complexity in terms of complex coding techniques.

David Gesbert *et al.* [22] have discussed the transition of the MIMO technology from single user to multi user systems. In first section of the work a brief overview regarding the single user MIMO system has been presented which basically discusses the role of multiple antennas in escalating the capacity of the user terminal with the aid of extra DOF that leads to increment in system reliability. Therefore, the MAC protocol in such systems are especially design in inflating the system performance for single user whereas in instance of MU-MIMO systems due to the usage of SDMA its design differs. In MU-MIMO system the main role is to suppress the inter-user interference and simultaneously to cater diversity to multiple user terminals. Also, this system does not require multiple antennas at the terminal site for achieving all the MIMO gains as it could be achieved using single antenna but at the cost of reduction in system mobility and increment in complexity of system to have full information about the user channel. So, the role of CSI at transmitter site in achieving the multiplexing gain has been evaluated. This information aids the system in enhancing performance both for BCs and MACs channels along with linear and non- linear precoding techniques. But in realistic environment, there could be only possibility of having partial CSI at transmitter. Therefore, the authors have introduced some techniques based on quantization in the instance of limited feedback. So, that such limitations must not hinders the system achievable rate. In addition to this, they have also laid importance to various scheduling and resource allocating algorithms along with precoding schemes for optimising and enhancing system performance.

Andrea Goldsmith *et al.* [23] have examined the capacity gains achieved by the various MIMO systems under quixotic conditions. It has been found that under such conditions in case of both constant and time varying channels where the channel information is available at transmitter or receiver, these systems are able to achieve immense data rates. But under practical situations, there is a great decrement in the capacity gains in comparison to the ideal one. In context of time varying channels, the authors in this work have considered different models based on correlation between channel parameters and antenna elements and also on the information of channel available at the transmitter or receiver. Then the authors have further provided the analysis of capacity gain for the single user MIMO system and have observed that the gain for this system highly rely upon the channel SNR, CSI/CDI (Channel Distribution Information) at transmitter and receiver and correlation in-between the channel gains of various antennas. Then in the other segment of this paper, the authors have laid focus in finding the capacity gains of MU MIMO systems for both broadcast and MACs transmissions and have found that it is quite challenging to find results for these systems especially for the case of downlink. Because, in case of MACs the channel gain can be easily represented using convex functions but in case of BCs it could not be represented using convex and concave problems, therefore DPC scheme is used for the evaluation of such systems. Also, because of the duality existing between MIMO MACs and DPC region of achievable rate in MIMO BCs, the capacity of downlink could also be evaluated from the unions of all capacity gains of uplink channels. But all these evaluations of capacity gains are only possible for ideal cases i.e. when transmitter and receiver are familiar to the channel state but in case of

practical situations it is difficult to estimate. In addition to this, the authors have also provided brief introduction to the capacity of the multicell MIMO systems.

Semih Serbetli *et al.* [24] have proposed an algorithm for finding out the optimal precoders and decoders for the uplink MU-MIMO systems. The main focus of the authors in this work have been on the reduction of MSE using joint optimization for upgrading the system's performance. So, numerous algorithms have been proposed throughout paper for optimizing transmitter and receiver. First, the authors have proposed two algorithms that work separately for achieving the optimized transceiver pair for the system based on the transmission of multiple symbols from each user. Simultaneous updates are made available to the users with the aid of first algorithm and second one finds out the best transmitter set which transmits equal power to the all multiple symbols that are to be transmitted from each user. In comparison to these approaches, the authors have also proposed an iterative algorithm for the case which transmits only single vector from each user specifically for rapid convergence. So, using such algorithms the authors have evaluated the systems performance in each case and have tried to find out optimized solution for these cases. With the assistance of these algorithms in this paper, a relationship between the number of symbols required for transmission from each user and system's performance has been derived. According to this concept only as much symbols must be transmitted that should not cross a particular threshold level after which the system's performance degrades. Further, the authors have implemented all these approaches only for the channels which are less prone to error and suffers minimum delay. So, there is no information is provided in relation to the realistic implementation.

Sriram Vishwanath *et al.* [25] have proposed the relationship between MU-MIMO BCs and MU-MIMO MACs in finding the sum rate capacity. As, in uplink case of MU-MIMO systems, it has been comparatively easy to find capacity gains for such regions but in downlink case due to inadequate approach availability especially for non-degraded channels this task becomes quite tough. Earlier some researchers have found the achievable rates specifically for the 'dirty paper region' for these systems using dirty paper scheme and examined that the sum rate capacity of BCs is equivalent to the maximal sum rate of the MACs for all users. But with usage of this DPC technique, there has been great increment in the computational complexity of system and further this technique also could not be used for all the general cases of channels. Due to presence of equality between the sum rate of these two different transmissions, the authors have determined the duality between the capacity region of MIMO BCs and MIMO MACs channel. Using this technique there is decrement in computational complexity and also, it proves that the 'dirty paper region' in BCs channels attain the sum rate capacity.

Lai-U Choi *et al.* [26] have determined a pre-processing scheme for the BCs of the MU-MIMO systems. This approach basically breaks down the MU-MIMO BCs into various separate single-user downlink channels for MIMO systems. Such that each of this independent channel has the similar characteristics and properties as of conventional point-to-point MIMO system. Due to this all of the techniques such as SVD, BLAST and many more which are applicable to single user MIMO could also be applied to these independent downlink channels for MU-MIMO systems. Also, it has been shown that for these

systems the capacity increases linearly with increment in number of antennas and this could be also increased even for the case when there is finite number of receiver antennas present. Further the performance of the MU-MIMO downlink system with the proposed pre-processing technique has been evaluated with the assistance of simulations.

Christoph Windpassinger *et al.* [27] have laid focused on the Tomlinson-Harashima precoding (THP) technique which was initially developed for SISO systems but later could also be used with MIMO channels. This technique basically assists the MIMO systems in overcoming the drawbacks of Decision Feedback Equalization (DFE) such as in case of the precoding schemes all the process is performed at transmitter side which avoids the transmission of errors and reduce the complexity at the user terminals whereas in DFE most of the functionality is performed at the receiver side. Moreover, it has been found that this nonlinear scheme provides much better performance in comparison to the linear ones. But to implement this technique, the authors have assumed some assumptions in which the transmitter must have the perfect knowledge of CSI along with the less variant transmission channel. Further, this THP technique also assist the system in achieving appropriate capacity equivalent to as achieve by SVD scheme. In addition to comparing THP scheme with other linear and DFE schemes, the authors have also mentioned some of the significant aspects which could enhance the overall system performance. In this context, various loading strategies have been introduced such as in instance of optimum performance, there must of equal division of rate and power among the numerous parallel channels generated with aid of precoding schemes. Along with this, the authors have also discussed the role of signal shaping in combination with the precoding technology for boosting up the system performance.

Masoud Sharif *et al.* [28] discussed the significance of CSI in MU-MIMO systems in comparison to the point-to-point MIMO systems. But in realistic situations where the channel keeps on varying with time along with inexact feedback and less number of resources, makes it nearly impossible for the system to acquire perfect CSI. So, in such cases, there could be only availability of partial knowledge of channel rather than perfect. Therefore, in this work the authors have discussed some transmission approaches which could work accurately even in the presence of imperfect CSI. One such algorithm has been proposed by authors in which they transmit 'M' (number of transmit antennas at the base station) number of beams for selecting the users having highest SNRs. Further, this algorithm has been analytically evaluated, by varying the n (number of users) and keeping number of transmit antennas constant. From the observed results for this evaluation it has been found that the throughput of system varies according to the equation $M \log \log n$ which is further equivalent to the capacity achieved by DPC in the presence of complete CSI. Moreover, in order to vary the capacity linearly with respect to M, the value of M should not expand quicker than the value of $\log n$. With the assistance of this proposed approach of random beam, it has also been proven that with any value of 'N' there is no effect on the throughput of system and it still remain equivalents to the capacity of DPC. In addition to this in the last segment of the paper the authors have introduced the effect of heterogeneous users and have observed that with increment in the value of M will lead to fairness in the scheduling system. Further,

if the value of M becomes larger than the $\alpha \log n$ then the scheduling of the system becomes independent of the SNR. Hence, $M = \alpha \log n$ has been considered as the acceptable operating point for achieving beneficial throughput as well as fairness in the system.

Mirette Sadek *et al.* [29] have proposed a beamforming scheme which is focused on escalating the Signal to Leakage and Noise Ratio (SLNR) for the users rather than Signal to Interference Plus Noise Ratio (SINR) as in instance of other precoding techniques. Primarily, in case of MU-MIMO broadcast system, one of the most significant aspect is to subdue the CCI which is executed by applying numerous techniques at the source and destination sites. But these schemes for reduction in CCI implements constraint on systems especially on the number of antennas at the transmitter and receiver sites. According to this regulation the number of antennas at the transmitter sites must be greater than the sum of all user antennas in order to yield the appropriate degrees of freedom, especially to implement various linear precoding schemes. In some other techniques for optimizing the system performance maximization of SINR is executed by the various precoders and decoders. But with the implementation of these techniques no closed form result is obtained, as such schemes lead to increment in intricacy of the system along with the coupled structure of this emerging problem. Therefore, in this work the authors have proposed the precoding scheme based on concept of leakage. Also, the implementation of this scheme in systems does not impose any limits on the number of antennas at base station or at all user terminals. Moreover, this scheme also considers the consequence of noise on the system contrary to the ZF approach. Therefore, with the assistance of simulations it has been proved that SLNR based systems surpasses the performance of systems based on CCI. In this work the authors have evaluated the performance of leakage-based system by using various expansions such as operating the system using alamouti coding for both single stream per user as well as for multiple streams per user and the consequence of erroneous channel on system performance.

Qinghua Li *et al.* [30] have introduced the role of MIMO technologies in IEEE 802.16m and 3GPP LTE-A wireless standards. In comparison to earlier technologies the MIMO system used in these systems is based on multiple access by various users which further leads to boost up the system data rate and throughput. Also, this evolution from single user MIMO systems to MU MIMO systems plays a significant role in transition from 3G wireless standard to 4G wireless standard. Basically, this paper discusses and provide comparison between the MIMO technologies of these two mentioned standards. In addition to this, it also provides overview of various schemes such as Space Frequency Block Codes (SFBC), open loop, closed loop techniques and many more related with the introduced standards.

2.4 MIMO-OFDM System

Helmut Bolcskei [31] has discussed the significant of OFDM system in reducing the effect of ISI when it is combined with MIMO system especially in case of frequency selective channels. This combination provides an enticing air- coalition for the near future wireless communication for contributing in high QOS along with high data rates. Due to such enhanced performance this combination has been used in various wireless standards such as IEEE 802.16 WMAN, IEEE 802.11 WLAN and many more

technologies including fourth generation wireless communication. So, therefore in this article the author has primarily laid emphasis on the fundamentals of MIMO-OFDM system, its design and complications related to its hardware implementation. In addition to this, the author has also discussed the usage of MU-MIMO system in place of point-to-point MIMO systems in MIMO-OFDM combination. This MU-MIMO OFDM system provides additional benefit in terms of multiple access by various users which adds on to the overall throughput. Further, in the last segment the author has also mentioned the research areas related to MU-MIMO that are need to be focused such as its effect on higher layers, physical layers and its practical implementation.

Allert van Zelst *et al.* [32] have described the importance of MIMO-OFDM system in enhancement of the link reliability and throughput. In this, the MIMO part used provides increment in the system capacity using SDM technique and OFDM increased the robustness against the ISI. So, due to numerous advantages over the earlier WLAN systems such as IEEE 802.11a and IEEE 802.11g, this combo system has been used in the extension version of WLANs. Further, the authors in this work have also mentioned the significant modifications that are required to be made for its efficient implementation such as first major change is need to be done in the baseband processing, then extra care must be taken for maintaining the channel information and synchronization, so that the system has been avoided from the effects of time and frequency offsets. Also, along with this the authors have proposed schemes for boosting up the MIMO system performance. These approaches are primarily based on horizontal coding, per antenna coding at V-BLAST and maximum likelihood detection which is executed at the transmitter site of the system. Further, for the verification and analyzation of the proposed schemes the simulations are performed for the MIMO-OFDM system comprising of three transmit and receive antennas in both ideal and practical environments. It has been observed from the results that in realistic situation, the throughput obtained from 3×3 system is only two times larger than that obtained with 1×1 system instead of tripling it. This effect is mainly due to the existence of mutual coupling in antennas at the transmitter and receiver sites. In addition to this, the degradation has been shown in performance of the BER and packet error rate for practical situations in comparison to the ideal cases because in the evaluation of ideal cases the effect of quantization and phase noise has not been taken into consideration.

Gordon L. Stuber *et al.* [33] introduced the role of OFDM system along with multiple number of antennas in enhancing system capacity. These systems work efficiently and provides reliable communication even in the presence of time varying channels. In this paper, the authors have first laid importance on the challenges which are related to physical layer of the system. Particularly for the receiver parts of the system it becomes necessary for them to acquire all the information related channel measurement and synchronization of both time and frequency. This action for this system has been accomplished using the training sequences in the preamble part of the system. So, with the aid of these training sequences the error in the synchronization or estimation could be detected and corrected for accurate detection of the desired signal. So, this paper has provided various algorithms related with the

channel estimation and effective designing of preamble and packet for the symbol. Further, a brief introduction related to space time and frequency coding schemes have been discussed for achieving high diversity performance in the system. In addition to this the authors have also presented the low complexity algorithms based on the selection of only the required antennas and beams using which the still the demand of requisite diversity and multiplexing could be achieved.

Imad Barhumi *et al.* [34] have discussed the optimal methods for estimating the channel in MIMO-OFDM systems. Channel measurement has a great significance in detecting and evaluation of data along with equalization at the receiver site. In this work, the authors have mainly laid focussed on the channel estimation based on training sequences. In such systems before the receiving of data, the receiver is informed about the characteristic of channel using some sort of pilot symbols or sequences. So, this paper basically represents the measurement of CSI with the assistance of least square estimation that relies on pilot tones. In order to implement this scheme, first the MSE of this channel estimate is calculated. So, depending upon this MSE optimal pilot sequences and their respective organizations are analysed such that these chosen optimal sequences must have orthogonal phase shift along with distribution of equal power and space among them. Further, it has been found that with the usage of such pilot sequences there has been increment in the overall overhead of the system. So, to overcome this problem the channel estimate has been measured over numerous number of symbols rather than one. Moreover, for further increase in accuracy of channel measurement, a recursive based least square algorithm has been designed based on tracking factor which further relies on doppler effect and variance of noise for its performance. In addition to this, the performance of the proposed scheme in this paper has been evaluated using simulations. It has been further found that this new scheme surpasses the other conventional schemes of pilot sequences.

Pengfei Xia *et al.* [35] have designed a two-dimensional beamformer for the MIMO-OFDM system in the instance of partial channel information. These designs which are basically introduced for the uncomplete channel knowledge are of significant importance to practical implementation. Because to acquire such perfect CSI in realistic environment is almost impossible. Therefore, the authors have first proposed a MIMO-OFDM model which is particularly based on availability of only partial CSI. Further to enhance its performance at each subcarrier, a 2-D beamforming scheme based on coding has been introduced. This beamforming technique combined with effect of optimized transmitter for the evaluation of power and size of symbols that are to be transmitted across the numerous subcarriers has been an important aspect in this type of systems. In this work, the author has laid focus on boosting up the system performance for the case of especially partial CSI in presence of frequency selective channel and consisting of the restrictions such as finite power and fixed BER performance for each of the subcarriers of OFDM. Further, with the aid of analytical measurement, the performance of 2-D beamformer is evaluated for the system consisting of M-ary QAM scheme and has been found that this system leads to effective improvement in data rates.

Zhanji Wu *et al.* [36] have designed a transmission scheme for SU-MIMO OFDM system and for MU-MIMO OFDM system. This proposed approach enhanced the functionality of IEEE 802.11 ac WLAN standard by adding 2-D modulational diversity. In addition to this for the proper usage of the available diversities i.e. space, time and frequency in MIMO-OFDM system the authors have developed an efficient interleaver. Along with this interleaver, a rotated modulation scheme has been collated to acquire the intrinsic diversity. With the usage of both interleaver and diversity techniques, an optimized transmission scheme has been introduced with minimum computational complexity. This technique leads to effective usage of the FEC codes in data streams along with the optimized usage of the diversity approach in all three dimensions i.e. space, time and frequency. Further with the assistance of simulations it has been proved that this scheme outperforms the conventional IEEE 802.11ac in terms of SNR gain.

Ming Jiang *et al.* [37] have provided a detailed information on the MIMO-OFDM systems. It basically discusses all the advancements and limitations that are met by these systems in their evolution phases. In the first section of this paper, the author has laid its focus on the restraints that are encountered by the earlier systems in estimating the channel and detection of signals due to the occurrence of rank deficiencies. In such conditions, there is increment in the number of users in comparison to the receive antennas due to the coverage area provided by the base station. So, to handle this situation the appropriate techniques are needed to be applied which manages the radio range of the base station. Moreover, the authors have also discussed the limitations in relation to the detection techniques of MU-MIMO OFDM systems. As, in these techniques with increment in number of users the system implementation becomes more complex along with the degradation in system performance. So, this hindrance of the system could be resolved using appropriate channel estimation approaches. But with the usage of such schemes there has been found reduction in the mobility and throughput of the system. Therefore, in place of such MU detection schemes the authors have introduced Genetic Algorithms. These algorithms aid the system in endorsing a greater number of users in comparison to the least square and maximum likelihood detecting techniques. In these Genetic Algorithms (GAs) the exception process is random in nature and is executed using iterative algorithms. Further, it has been observed that the computational complexity with increment in the user number in these algorithms is less in comparison to the earlier ones. In addition to this, the authors have concluded that in near future the other genetic basis schemes, GA or their hybrid coalition would lead to better results in these systems which includes multiple users.

Mirette Sadek *et al.* [38] have proposed a precoding scheme based on SLNR in case of downlink MU-MIMO OFDM system. The scheme introduced was initially used for the case of single user MIMO systems but now it has been extended for the instance of multiple users. It primarily focusses on the minimization of inter-user interference using the coding technique based on space frequency approach. The SLNR used instead of conventional SNR techniques assist the system in performance of optimal user scheduling. Primarily, both these SLNR and SNR are used in the algorithms for determining the

quality of the user channels. Further, it has been found out that this scheme performs better even in the case when ideal CSI is not present at the transmitter. In addition to this, the performance of this scheme has also been observed with the aid of numerical analyzation and has found that this scheme outperforms the other schemes in terms of performance.

Parag Aggarwal *et al.* [39] have evaluated the effect of non-linearity present at the transmitter sites on the system performance of MU MIMO-OFDM system. The main cause behind the introduction of non-linearity at the transmitter sites especially in the case of OFDM systems are HPAs. As, with the presence of high PAPR in OFDM systems has forced these HPAs to work in the non-linear region leading to degradation in the system performance. In this work to measure the impact of non-linear region, the authors have chosen the MU-MIMO OFDM system for downlink case with SVD approach. With the usage of this decomposition scheme the inference existing between the multiusers is eliminated. Further for the calculation of the non-linear characteristic of HPA, memory polynomial technique has been considered. So, with the aid of this technique, the analyzation of the effect of HPAs on system performance has been measured at the user ends in terms of Symbol Error Rate (SER). Further, it has been found from the observations that consequence of using HPAs in MU-MIMO systems is quite distinct from that used in single user case. In addition to this, it has been also analysed from the observations that the deformity in the system performance due to non-linearity is a function of the number of users present in the system. Therefore, with the increment in number of users the system performance gets more and more worst.

2.5 Massive MIMO System

Thomas L. Marzetta [40] has provided a detailed discussion on large scale antenna system and their requirement in satisfying the ever-growing demand of data rate. The author has mentioned that within near future the demands of data rate would expand to such large amount that it would not be possible for the earlier technologies to meet that. Therefore, the invention of Massive MIMO technology consisting of large number of service antennas has proved to be a boon for the wireless communication because with the increased number of service antennas this system provides a great increment in the spatial multiplexing and diversity of the system which further adds on to the reduction in transmission power, increment in selectivity, throughput and declination in the processing complexity of the system. Further the author has also laid focussed on the concept of attaining CSI for this large antenna system. In these systems, the CSI is particularly needed for the case of downlink transmission. As this required channel information for the purpose of resolving inter-user interference at the user ends. To acquire CSI in such cases, it only depends upon the number of user terminals and not on the service antennas which further leads to reduction in complexity. But for this purpose, the system could only work in TDD mode as this mode works on the principle of channel reciprocity, due to which the base station easily gathers the channel information from the pilots of uplink mode. Other than this the author has also provided the brief overview on the earlier schemes from which the massive MIMO technology has been evolved such as point-to-point MIMO and multiuser MIMO systems.

Erik G. Larsson *et al.* [41] have provided an introduction to the concept of Massive MIMO and various challenges associated with it. First, the authors in this work have described the concept behind the transition in the technique from SU- MIMO to MU MIMO and then from MU-MIMO to Massive MIMO systems. It has been discussed throughout the paper, that the Massive MIMO concept has more capability than MU-MIMO in providing the system large data rates with scarce resources of spectrum. The main difference between the two are the increased number of service antennas which leads to provide extra degrees of freedom to these systems. Also, another important distinction between the two systems is that MU-MIMO can operate either in TDD or in FDD mode whereas this hyper MIMO system could only work in TDD mode due to reciprocity property which further leads to decrement in the system complexity of obtaining CSI. Further the extra DOF in the system are responsible for increasing the system throughput, spectral efficiency and reduction in transmission power by concentrating the signal energy directly into small places. Also, with the usage of this concept, there is great reduction in hardware parts. As in comparison to accurate and expensive large components these systems only require small economical and low power-based components. The other assets of this Massive MIMO systems as mentioned in the work are resistance to the deliberate jamming, latency and reduction of the complexity of MAC layer. In addition to the numerous benefits associated with this new technology, the authors have also provided the numerous challenges which came into existence. Such as, the problem of making these low-cost components to work jointly in synchronization, proper usage of the extra DOF and management of the power consumption. Also, due to increment in the antennas at the base station site this system requires new deployment techniques for its implementation and effective working.

Lu Lu *et al.* [42] have provided an exhaustive overview on the hyper MIMO system. In first segment the author has mention the requisite of these large antenna system in comparison to the other MIMO technologies. Due to the inability of MU-MIMO system in handling a greater number of users along with increase in system complexity has led to the formulation of this massive technology. This technology eliminates the complex precoding techniques and use only linear ones. Because in these systems using even these simple processing techniques leads to reduction in the inter-user interference and large gain in data rates. Also, the availability of extra DOF aid the system in forming the beam in desired direction which further leads to efficient energy management. It has been also mentioned in the paper that due to present of such large arrays at base station, the transmission energy of each antenna at the user end could be decreased equivalent to number of service antennas in the instance of ideal CSI and to the square root of the same in the instance of imperfect CSI. Also, if the transmission energy is available extra then required, it could be further used in enhancement of the system range. Along with all this, the authors have also discussed the optimum transceiver designs and also various propagation effects associated with the system. In addition to this the effect of usage of non-orthogonal pilots due to availability of limited number of orthogonal pilots has also been analysed.

Emil Bjornson *et al.* [43] have discussed the impact of imperfect hardware on the system performance. Basically, the authors in this work have analysed the transceivers at both ends i.e. base station and user terminals. In the first segment of paper the authors have discussed the role of massive MIMO systems in providing the desired spectral efficiency as required by future generation. This has been possible due to the increase in ratio of antennas at base station in comparison to the user ends. Due to this property there has been huge increment in the spatial resolution and multiplexing gain. Also, the usage of such systems eliminates all the problems caused by earlier techniques such as losses encountered during propagation, inter-user interference, system complexity and errors in channel estimation. Due to such assets, this system has become one of the most desired technologies as its implementation is also economical with the usage of large scale low cost and low power components. But after the analysis on the hardware system it has been found out that these hardware impairments result in degradation in the system overall performance. The inexpensive hardware usage leads to an increment in system non-linearity, particularly in amplifiers, phase noise and other imbalances in the system. These all impairments directly affect the achievable rate in the uplink and downlink cases and also the accuracy achieved in channel estimation. To reduce such effects, many compensation schemes have been developed but still the effect could not be completely eradicated. Further, it has been observed from the evaluation of Massive MIMO systems that the effect of these impairments at the transceiver of the base station side is negligible. This has been possible with extra DOF available due to a large array of service antennas. But the decrement in capacity of the system is still there due to the transceiver at user terminals.

Emil Bjornson *et al.* [44] have provided comprehensive discussions on the myths and questions related to full dimension MIMO. This is because as this topic has been a current topic of research which could solve all the problems related to the scarce spectrum and energy resources. In the first part the authors have discussed the concept related to massive MIMO and its associated effects that are necessary for its implementation. Such as the working of the system in TDD mode and in the presence of both single and multicarrier transmission schemes. Therefore, it provides an introduction to the concept of Massive MIMO-OFDM systems. Further, on the misconception related to the usage of processing techniques and its complexity due to a large antenna array has been resolved by discussing the concept related to linear precoding techniques such as ZF, Minimum Mean Square Error (MMSE) and Maximum Ratio (MR). Further, another misconception related to the working of hyper MIMO in the millimetre wave band has been solved by giving various statistical information. The authors have further explained that the concept of massive MIMO can be implemented for both the wave bands i.e. below 6GHz and mm-waves but the only difference would be in the hardware parts of the system. Then the second myth in this context has been regarding the usage of this system in only high scattering channels. Therefore, for the explanation of this concept the authors have provided an example that provides an excellent result while working in two extreme environments. In this way the authors have resolved the total number of ten critical myths such as regarding performance gain in an open-loop scheme, realization of asymptotic results, degradation in system performance using linear precoding, and requirement of number

of service antennas in relation with user terminals, employment of new user end, high cost precision hardware requirement, increased computational complexity in allocating power, resources and signal processing evolved for large antenna array. In addition to this, the authors in the last segment of the work, have discussed an answer related to a significant question related with the working of this large dimensioned MIMO system in FDD mode which could lead to increment in the system mobility to a large extent. So, to solved this the authors have introduced the concept of channel sparsity which could be easily available in mm-Wave band.

Emil Bjornson *et al.* [45] have introduced the concept of optimal performance in Massive MIMO system depending upon the number of users and pilots in the system. As these systems are responsible for meeting the future generation demands due to increment in spectral efficiency with the deployment of vast number of active antenna elements at the base station. In this work, the author has also mentioned one thumb rule i.e. $\frac{M}{K} > 10$ where 'M' depicts the number of active service antennas and 'K' depicts the number of users ends and if this rule has been followed by the system then nearly all the user channel existing in the system would be orthogonal to each other. But still the main focus of this paper has been maintained to actually estimate the number of users scheduled at a time in a given cell for achieving the maximum value of the efficiency of the system. So, therefore in this the authors have analysed the various parameters such as number of pilots actually present in the system, number of antennas, components, channel block length for which it is coherent in nature and many other parameters which could affect the scheduled number of users. Relying on these parameters the authors have derived the new equations for spectral efficiency which could be used for both uplink and downlink case and moreover these equations has been derived for the instance of random locations of user and uniformly divided power control system. As, these massive MIMO systems prefer linear coding techniques for inter user interference cancellation using the channel information received from the pilots. Therefore, the authors have derived these new equations also by using various linear precoding schemes such as ZF, maximum ratio transmission and full pilot ZF schemes. Moreover, the authors have derived the value of number of users in the system for different practical scenarios such as at some constant values of M, for different reuse factors related to pilot schemes, distinct interference situations and many more. Further, after observing the performance of 'K' for this much different factors, schemes and parameters. It has been found out that the value of 'K' gets more effected by using different precoding schemes.

Li You *et al.* [46] have discussed the algorithm for management of the pilots for avoiding pilot contamination and overhead in wideband massive MIMO systems. In this context, the authors have introduced the concept of adjustable phase shift pilots which is quite different in comparison to the conventional system of phase shifted pilots. So, in order to track and analyse the channel estimation and acquisition with new concept of pilots the authors have first organised the link between the correlation and the delay spectrum for the power angle of the proposed channel. So, with the aid of this relationship it becomes easy for the system to track the sparsity of the channel. From the evaluation of the channel acquisition in accordance with MSE could be reduced to a small value only for that cases of user ends

whose dispersion of power in angle-delay spectrum of the channel is non-coinciding with accurate arrangements of phase shifts. Further the authors have also proposed an appropriate algorithm for organization of phase shifts in pilots in the presence of optimal channel procurement. Then for the evaluation of the system performance based on the concept of adjustable pilots two data models consisting of one and multiple symbols are considered. From these evaluations it has been observed that this new concept of adjustable pilots overlays the performance of conventional phase shift pilots in terms of achievable throughput and spectral efficiency of the system.

Christopher Studer *et al.* [47] have provided a solution to the problem of high PAPR in massive MIMO-OFDM downlink systems. The problem of this PAPR has been inherited from the OFDM system which lead to the usage of expensive and high maintenance linear components at the base station for the reduction of radiation which are transmitted out of band and deformity in the signals. Due to this, there would be huge rise in the system complexity and cost if these linear components are actually utilized in the massive MIMO systems. Therefore, to minimize the effect of this PAPR there has been a requirement of an effective technique which could combat this effect and provide better results in comparison to conventional linear RF chains. So, the authors have introduced an PMP scheme based on the joint operation of precoding, modulation and PAPR declination leading to the optimal performance of the system. The proposed approach works on the principle of extra DOF in this large array MIMO system and exhibits a trade-off between the out of band radiation energy, PAPR and SNR. Primarily due to the presence of large number of null spaces in the channel matrix of this large antenna system, it becomes quite an easy task for the designing and precoding of such signals which could be able to provide small value of PAPR. Further the authors have devised this new scheme as convex optimization technique which could be realised using fast iterative truncation approach. In addition to this the authors have evaluated the performance of this PMP scheme by using the numerical analyzation method and have found that this new scheme suppresses the performance of conventional approaches by decreasing the PAPR value 11dB more than others. Also, with the addition of PMP approach in the system only the transmission process at the base station site gets effected. Therefore, it becomes simpler for the current systems to adopt this scheme without affecting the user ends.

Nusrat Fatema *et al* [49] have provided an exhaustive overview of the precoding schemes used in single cell and multicell massive MIMO systems. In such system precoding plays a significant role in removal of inter-user interference. So, in order to perform precoding, first the large antenna system acquire CSI from the uplink pilots using reciprocity property and use this information in precoding signals for the intended users. So, the main challenge in this precoding of signal is acquisition of channel information. If CSI is ideal then the link would also provide maximum performance. In case of single cell massive MIMO, the conventional linear precoding schemes are utilized instead of non-linear ones. So, in this paper the authors have provided detail description and comparison on the basis of their complexity, scalability, power efficiency and many more among the various linear precoding schemes. In second segment of the work the authors have introduced the multicell massive MIMO system and its

related precoding schemes. In such system the main problem which hinders its performance is pilot contamination. As, these systems required to reuse pilots in the nearby cells which could lead to errors in the acquisition of channel information. The precoding schemes discussed for these systems are first divided into two categories based on the cooperative and non-cooperative techniques. Here the cooperative word refers to the cooperation among the base stations of multicellular system. The cooperative techniques are further categorized on the basis of partial and full cooperation achieved among the base stations. Moreover, it has been found that the cooperative techniques perform much better than the non-cooperative ones at the cost of raised system complexity. In the last the authors have concluded that till date the appropriate techniques which could optimise the performance has been not found yet. So, research in this area is still continued in finding out the appropriate scheme which could overcome the existing challenges.

Foad Sohrabi *et al.* [52] have represented the role of hybrid beamforming in reducing the cost and complexity in the implementation of the mm-wave Massive MIMO systems. Primarily, with the implementation of each antenna in these systems a RF chain has been attached to it which consumes a lot of power. So, with the increment in number of antennas of the system this power consumption has grown to huge amount. Therefore, to resolve this problem the concept of hybrid beamforming has been introduced. For the implementation of this scheme the precoding process has been divided into two steps. In the first step, the digital beamforming technique with less dimension than the earlier fully digital beamforming scheme has been performed. After, processing the signal from digital beamformer, it is then passed through RF chains and finally through analog precoders for performing phase shifting of the signals. So, with this reduced hardware the main goal of this new beamforming scheme is to achieve almost the same performance as by the conventional beamforming techniques. In this paper the authors have evaluated that if the number of RF chains in this system is equivalent to the twice of number of data signals that are to be transmitted to the user, then this new scheme would be able to trace the performance of fully digital one. After, designing hybrid beamforming scheme for this hyper MIMO system the authors have also laid focus in designing this approach for the earlier MIMO technologies such as point-to-point MIMO systems and MU-MIMO systems. Then this new scheme has also been tested for their performance in practical scenarios which consist of phase shifters having finite resolution. From the numerical analyzation, it has been found that even with the usage of phase shifters having small resolution the performance of the system is almost equivalent to the full resolution one. But all these evaluations in the paper has been done by considering the case of perfect CSI which in realistic environments these conditions don't exist. So, more research has to be done to approach the performance of the perfect case with partial knowledge of channel.

Jiahui Li *et al.* [53] have proposed a scheme for the implementation of hybrid beamforming in uplink case of mm wave massive MIMO systems. As, in such systems, it is not possible to afford a RF chain along with each antenna of the system. Therefore, it has been important for these systems to imply a technique which could reduce the hardware without reduction in the performance. In this work, the

authors have first provided a brief introduction to the earlier invented hybrid beamforming schemes and their related factors such as complexity, constraints and limitations. It has been found that in these discussed algorithms the main causes of degradation in the performance are performance of system in low SNR and in multipath channel and also the presence of inter-user interference. Therefore, to counter such problems the author has introduced a new hybrid scheme based on low computational complexity and more resistance to the impairments. In this approach the main motive is the reduction of the existing inter-user interference which could severely affect the system performance. For this purpose, the analog and digital beamforming precoders are carefully designed to remove this existing interference. Also, in analog precoders, the Gram Schmidt approach has been used for the extraction of its vectors and MMSE precoding scheme has been employed in the digital beamformers. Then the performance of this scheme has been observed and has found that its performance much better than existing ones.

2.6 Gaps Identified

Based upon the literature survey reported following gaps have been identified:

1. Although the introduction of new transmit power allocation scheme for multiple users in OFDM system reduces the computational complexity of choosing appropriate user for each sub carrier in water-filling algorithm. But still the analytical part involves in the selection of set of users for the desired channel gain and without the interference among them on each subcarrier is a complex process. So, this technique of selecting appropriate users need to be designed efficiently for increasing the system throughput and its practical implementation [17].
2. The techniques provided for reduction of PAPR in [18], [19] and [20] must also considers the effect of these algorithms on hardware used in the system such as D/A converters, filters and many others in order to avoid degradation of the system. So, based on such effects the decision for designing or selecting appropriate algorithm for the given system in realistic environment must be made.
3. The linear and non-linear processing techniques in MU-MIMO systems requires the perfect CSI knowledge for their implementation which is not possible in the case of realistic environment. But if this accurate CSI is to be obtained in practical case, it can only be for the case of low mobility situations. So, there is need to develop the research work related to efficient working of system in imperfect CSI along with consideration of the various aspect such as errors occur in evaluation of channel, appropriate feedback techniques and many others [21].
4. In this paper [27], the Tomlinson precoding techniques is developed to overcome the problems of earlier DFE based processing techniques. But this technique is assumed to be implemented only for the cases of channel which are constant for some time. So, this technique cannot work for the applications which require mobility for their processes.
5. The research work done in area of MU MIMO-OFDM system, only focusses on the modifications and needs of physical layers. But the effect of the same on other higher layers in the system and the scheduling algorithms related to multiuser use is need to be determined and explored [31].

6. In [39] the authors have proved the adverse effect of HPA in increasing the non-linear distortions in MU MIMO-OFDM system and it becomes more severe as the number of users in the system are increased. Therefore, this issue should be need to research upon for finding the appropriate solutions.
7. The issues related to interference and energy management for the use of massive MIMO systems in heterogeneous network should be resolved for its efficient working [42].
8. Presently, Massive MIMO system operation can only be implemented in TDD mode. So, focus of research must be made in the direction of its operation in FDD mode which could reveal more chances of improvements in system efficiency, throughput and mobility [44].
9. The precoding techniques used in Massive MIMO systems are mainly developed for only the case of users consisting of single antennas. So, the issue of using more antennas at user terminals must be considered which could also make the system work effectively even in the case of partial CSI knowledge [49].
10. In [52] the hybrid beamforming scheme proposed, performs equivalent to that of linear precoding scheme with reduced number of RF chains. But this performance of its, is evaluated considering the effect of perfect CSI knowledge. So, there is need to explore this field for its working condition in imperfect CSI which makes the realistic implementation of Massive MIMO systems possible.

2.7 Objectives

1. Comparisons of the various MIMO-OFDM techniques such as point-to-point MIMO-OFDM system, MU MIMO-OFDM system and MU Massive MIMO-OFDM system on the basis of BER and achievability rate parameters for both uplink and downlink cases.
2. The performance evaluation of downlink transmission of MU-Massive MIMO-OFDM system using hybrid beamforming scheme for reduction of hardware complexity.
3. Comparison between the Phased Zero Forcing (PZF) hybrid scheme and ZF scheme in terms of BER, achievability rate and computational complexity for the case of broadcast transmission of MU-Massive MIMO system.
4. Performance analysis of downlink case of MU-Massive MIMO-OFDM system in the presence of two different FEC codes i.e. Convolutional code and Reed Solomon code.

2.8 Methodology

In this work, the focus has been laid upon exploring and analysing the techniques of MIMO technologies that are introduced in the wireless communication according to the growing demand of the data rates. Then the performance of all these techniques of MIMO systems after collating with OFDM system i.e. point-to-point MIMO-OFDM system, MU MIMO-OFDM system and MU Massive MIMO-OFDM system is examined using the stimulations obtained from the comparisons between them in terms of BER and achievability rate for the case of both uplink and downlink transmissions.

Further the main concentration of the work is applied upon evaluating and studying the performance of MU Massive MIMO-OFDM systems in presence of fully digital ZF and Phased Zero Forcing (PZF) hybrid beamforming schemes. The concept of hybrid beamforming scheme is introduced to the system so that the hardware complexity involve in usage of each RF chain with the corresponding service antenna at base station can be reduced [52]. For the reduction process in broadcast transmission using this PZF hybrid scheme, the precoder part of the system is divided into two parts. The first part i.e. digital precoder performs the effective low dimensional precoding technique on data streams in baseband domain. This baseband processing of the data signals is performed after analysing the equivalent channel from the product obtained by multiplying the RF precoder matrix with that of channel matrix acquired using the uplink pilots. In the second segment of the precoder, the data streams are than processed by the full dimension economical phase shifters in RF domain. So, using two different precoders in distinct domains, assist the system in obtaining the performance equivalent to that of conventional fully complex ZF scheme [51]. This performance of the system is verified using the comparison between the two schemes in terms of the BER, achievability rate and computational complexity. Further, for providing more enhancement to the system performance, two different types of FEC codes i.e. Convolutional and Reed Solomon codes are added to the data streams of the system and the same comparisons of BER and computational complexity for different precoding schemes is being performed and evaluated in comparison to the un-coded one.

CHAPTER 3

SYSTEM MODEL

In the first segment of this chapter the system model for MU Massive MIMO-OFDM System has been discussed. This model has been described for both the cases of downlink and uplink transmission with the detailed description of the various components and techniques used, along with their respective assets and limitations. After this, to solve the problem of hardware complexity and practical implementation of the system, the concept of hybrid beamforming has been introduced. Further in context of providing additional enhancement to system's performance, two distinct types of FEC codes i.e. convolutional codes and R-S codes are combined with the data streams.

3.1 Coded MU Massive MIMO-OFDM System with Conventional Linear Precoding and Decoding Schemes

This system represents a significant enticing air coalition between two major techniques i.e. Massive MIMO and OFDM. These two techniques play an important role in enhancing the system throughput in the presence of scarce spectral and energy resources. So, when they are used together they complements each other performance and provides a propitious approach for providing wideband transmission facilities. But the performance of this system depends highly on the CSI acquired at base station from the uplink pilots [46]. Further, the development of theory in case of uplink transmission of the system has been found quite similar to the point-to-point MIMO systems. Therefore, to design the system for uplink transmission has been quite easier in comparison to the system design of downlink system because in this system the main aspect is the removal of inter-user interference which is achieved using the various precoding techniques at base station [23].

3.1.1 Downlink/ Broadcast Transmission

Figure 3.1 represents the system model of downlink transmission in MU Massive MIMO-OFDM system. The system has been shown consisting of M service antennas along with K single antenna user ends where $M \gg K$. Due to the presence of extra service antennas, this system provides a large amount of extra DOF and it becomes quite easy for the system to focus the signal energy at the intended users without leakage. Further, in designing of this system it has been shown that with each service antenna there is requirement of separate RF chain and OFDM system which leads to increment in the system complexity, despite the usage of inexpensive and low power components. As, it becomes difficult for the system to adjust and manage the power requirements of such large number of service antennas [43].

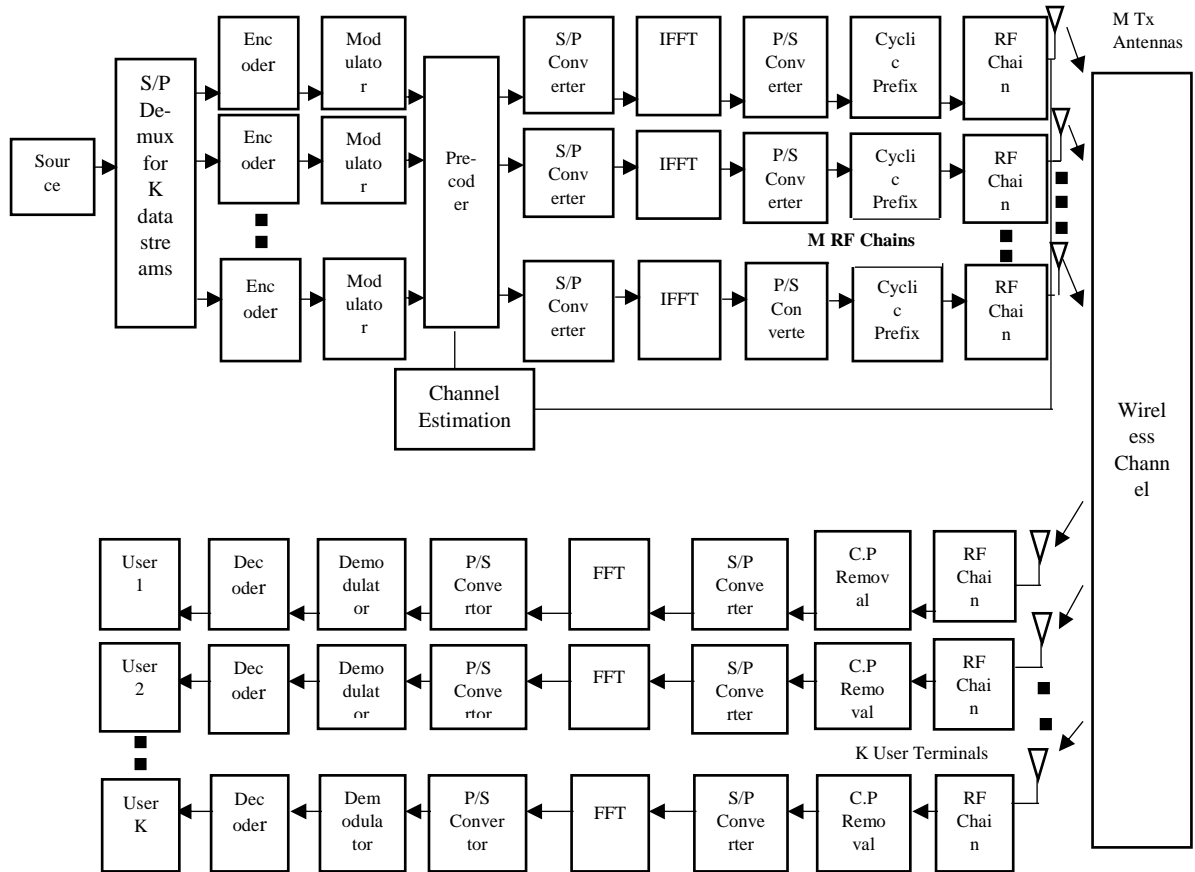

Figure 3.1 Block Diagram of MU Massive MIMO-OFDM System for Downlink Transmission

The detail description of the various components used in the system are:

3.1.1.1 S/P De-mux

This component has been used at the base station for conversion of the data generated by the source into parallel streams to be transmitted to K multiple users.

3.1.1.2 Encoders and Decoders

FEC codes / channel coding plays a significant role in improving the performance of the system by adding redundant information to the original signal. These codes are divided in two categories.

1. Convolutional Codes
2. Block Codes

1. Convolutional Codes

These codes are basically dependent on the memory elements for their encoding of data and are advantageous for the system in correction of random errors. As described earlier, two major parameters that provide a complete description of the codes are code rate and constraint length [55].

$$\text{Where code rate } r = \frac{k}{n} \quad (3.1)$$

Here, k represents the number of bits that are inserted at a time to the encoder and n represents the total number of bits that are produced by the encoder per cycle.

Another significant parameter of the system is constraint length depicted by K . This parameter mainly aids the system in calculation of memory elements present in the encoder [55].

$$\text{Here, } K = k(m + 1) \tag{3.2}$$

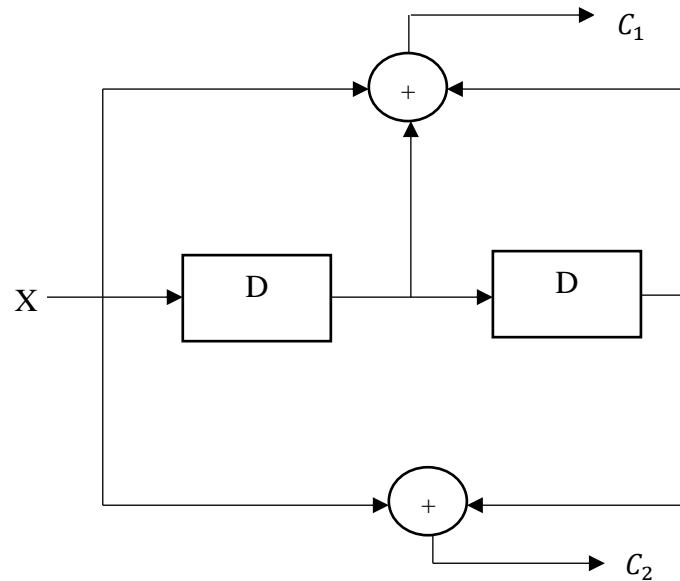

Figure 3.2 Convolutional Encoder showing $k=1$, $n=2$ and $r=1/2$.

At the initial stage of the encoding process, all the memory elements such as registers or flip flops are brought to all zero state. So, that it will be easy for the system to detect the start point of the coded sequence. The design of the encoder basically depends upon the generator polynomial that are used for the production of each output bit. These output bits are generated by performing the XOR operation on the respective input bits and bits store in the memory elements of the encoder. Figure 3.2 represents the encoder block diagram for the convolutional coding. In this diagram the encoder has been shown consisting of one input bit x and two output bits C_1 and C_2 with constraint length $K=3$. The generator polynomials for the given block diagram are represented as [55].

$$g_1 = [1 \ 1 \ 1]$$

$$g_2 = [1 \ 0 \ 1]$$

Further this convolutional encoder can also be depicted with the aid of finite state machine and its characteristic can be easily represented using state diagram. Figure 3.3 represents the state diagram of $(2,1,3)$ convolutional encoder where depiction of the transition for input=0 is done by solid line and for input=1 is by dashed line [55].

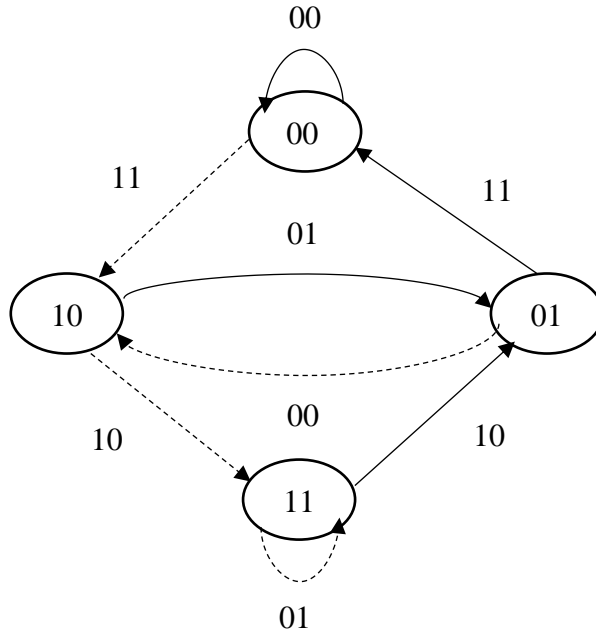

Figure 3.3 State Diagram representing (2,1,3) Convolutional Encoder Stages

Then from the aid of the state diagram, trellis diagram has been derived which further makes it easy in interpreting the notion behind the decoding of the coded sequence by Viterbi algorithm. Further, this algorithm is also of two types i.e. soft decision and hard decision decoding. For the system used in this work, hard decision decoding has been used. In the decoder similar to that of encoder the initial state is assumed to be all zero state which ease the process of decoding [55].

2. Block Codes

These codes are break the data sequence into small length finite blocks on which their coding operation is being performed. The Reed Solomon codes are most generally used block codes. They are used in variety of system such as storage devices or in communication applications and are mostly known for detection and correction of the burst error depending upon the characteristics and parameters used in the code. Primarily for the implementation of these codes, there is being requirement of different kind of arithmetic which is obtained using Galois field. Further, to implement this different arithmetic operations of this finite field a special kind of hardware and software needs to be used. Therefore, to use these codes first the data should be converted into finite field. As, in these codes both the generator polynomial and imitative coded symbols must belongs to the same field which further assists in reducing the complexity involves in computation of the system [56].

These codes are represented as R-S (n, k) codes where n represents the total number of symbols output from a R-S encoder and k represents the total number of symbols inserted in R-S encoder. The representation of total number of bits in each symbol is done by m. Here, n can also be represented using equation [56].

$$n = 2^m - 1 \quad (3.3)$$

Further, the length of block of the code is enclosed by finite field $GF(2^m)$.

Then code rate of these R-S codes is given as [56]

$$r = \frac{k}{n} \quad (3.4)$$

Then the expression for calculation of parity symbols added to per block of R-S codes is given as [56]

$$n - k = 2t \quad (3.5)$$

Where t represents the upper limit on the number of symbol errors if occur in burst can be easily detected and corrected.

The generator polynomial $g(x)$ in generic form can be represented as [56]

$$g(x) = \prod_{i=1}^{2t} (x - \alpha^i) \quad (3.6)$$

Where α depicts the primitive root for irreducible polynomial having degree m in $GF(2)$ field. Also, this α is represented in extension of finite field i.e. $GF(2^m)$.

Therefore, coding of data is represented as [56]

$$c(x) = g(x) \cdot i(x) \quad (3.7)$$

Where $i(x)$ represents the data input to encoder and $c(x)$ depicts the coded data.

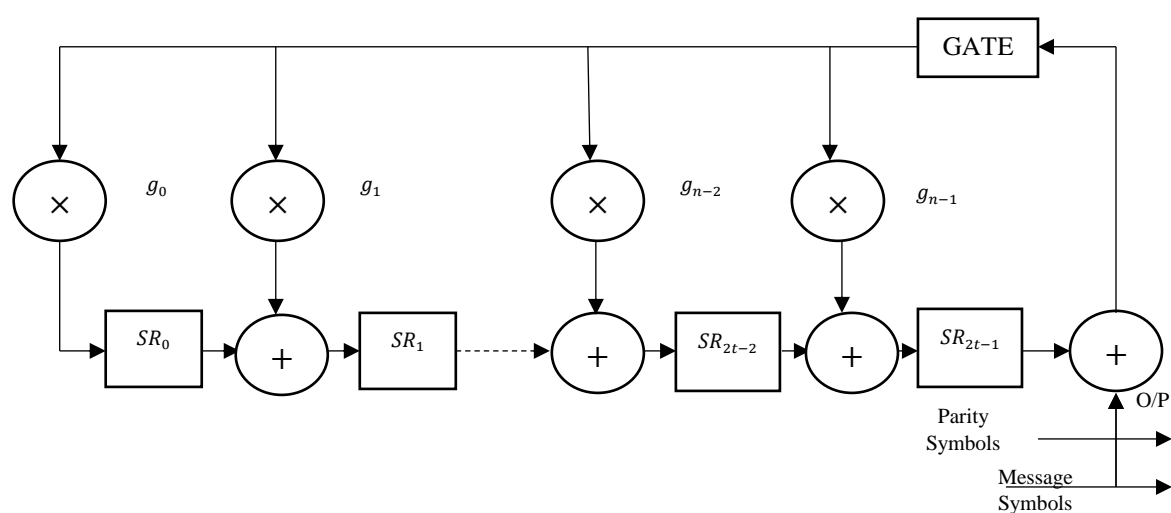

Figure 3.4 R-S Code Encoder

Figure 3.4 represents the block diagram of R-S encoder having $2t$ shift registers. Further, the adders and multipliers represented in the diagram follows the arithmetic of Galois field.

At the receiver side, the coded sequence is a combination of original data along with noise. It is represented as [56]

$$r(x) = c(x) + e(x) \quad (3.8)$$

Therefore, for the detection of the original message from the received coded sequence, some general steps are followed.

1. First the syndromes which are $2t$ in number are analysed by putting the $2t$ roots of the $g(x)$ into $r(x)$. These syndromes are primarily dependent upon the errors in the code [56].

2. After finding the syndromes then their location has been searched which implicates the calculation of polynomial that can locate the error using Berlekamp-Massey and Euclid's schemes and after this the roots of this new polynomial is calculated using Chien search approach [56].
3. Then the last step includes the measurements of the values of the errors in symbols using Forney algorithm [56].

3.1.1.3 Modulation and Demodulation Blocks

Primarily, in OFDM systems each data-stream is modulated using conventional digital modulation schemes such as BPSK, QAM, QPSK. Using these modulation schemes the data-stream is converted into required frequency configuration before getting transmitted on parallel streams of sub carriers [11]. At receiver side the demodulation is performed on the received stream, so to retrieve the data-stream into its original form [11].

3.1.1.4 Precoding/ Beamforming Techniques in Broadcast Transmission

In MU Massive MIMO systems linear processing techniques are preferred over the non-linear ones. Although the non-linear ones provide more optimal performance but at the cost of raise in complexity of the system. Therefore, these non-linear approaches for precoding is not suitable for the hyper MIMO systems, where this complexity problem will become more severe with the usage of large number of antennas. So, linear techniques are brought in to use which provides nearly optimal performance with the use of service antennas at large scale. In this work, for the design of this downlink transmission model ZF technique has brought into use [57].

Commonly use linear precoding techniques are

1. Maximum Ratio Transmission (MRT)
2. Zero Forcing (ZF)
3. Minimum Mean Square (MMSE)

For explanation of these schemes in MU Massive MIMO-OFDM broadcast system with M service antennas and K single antenna user ends the channel matrix is denoted by H where $H \in \mathbb{C}^{M \times K}$. Further it has been assumed that all the factors of H are independent with identical gaussian distribution consisting of zero mean along with unit variance. Also, the representation of the channel vector between the base station and kth user end is done using the notation h_k having dimensions equal to $M \times 1$. This h_k basically signifies the kth column of the channel matrix H [57].

The received vector at kth user terminal, in downlink transmission can be written as [57],

$$y_{dl,k} = \sqrt{p_d} h_k^T x + z_k \quad (3.9)$$

Here the additive noise at kth terminal of user is denoted by z_k and p_d denotes the average SNR.

Further, the combine representation signal for all K users is given by [57]

$$y_{dl} = \sqrt{p_d} H^T x + z \quad (3.10)$$

where x represents the data, vector transmitted from the M service antennas. It is basically formed by the combination of precoding matrix W with data vector q intended for K user terminals. It is mathematically represented as [49]

$$x = \sqrt{\alpha}Wq \quad (3.11)$$

where the α denotes the scaling factor for the normalization of the power of signal.

Then putting the value of x in (3.10), the equation acquired is given by [57]

$$y_{dl} = \sqrt{\alpha p_d} H^T W q + z \quad (3.12)$$

In case of kth user this equation of received vector is given by [57]

$$y_{dl,k} = \sqrt{\alpha p_d} h_k^T w_k q_k + \sqrt{\alpha p_d} \sum_{k' \neq k}^K h_k^T w_{k'} q_{k'} + z_k \quad (3.13)$$

Here, w_k and q_k represents the pre-coded vector and data vector intended for the kth user.

In case, of non-linear techniques such as DPC, the achievable rates achieve can be considered as an optimal limit that can be reached in case of hyper MIMO Systems, which is given by formula

$$C_{DPC} = \max_{\{q_k\}} \log_2 \det(I_M + p_d H^* D_q H^T) \quad (3.14)$$

Here, D_q denotes the diagonal matrix for allocating power.

Further, $q_k \geq 0$ and $\sum_{k=1}^K q_k \leq 1$ which represents the kth diagonal element of D_q .

At kth the value of SINR is given as [57]

$$SINR_k = \frac{p_d |h_k^T w_k|^2}{p_d \sum_{k' \neq k}^K |h_k^T w_{k'}|^2 + 1} \quad (3.15)$$

So, with the use of this equation for each user end, the achievable sum rate R in instance of various linear precoding schemes has been calculated using the formula [57]

$$R = \sum_{k=1}^K E\{\log[1 + SINR_k]\} \quad (3.16)$$

For finding out the precoding matrix some common schemes used are:

1. Maximum Ratio Transmission (MRT) Beamforming Scheme

This scheme directs the beam in the direction same as that of channel vector between base station and kth user end. Mathematically, the precoding matrix of this approach is simply the conjugate part of the channel matrix H [49].

$$W = H^* \quad (3.17)$$

It basically works by maximizing the power of received data signal at the desired user end and does not involve the aspect of inter-user interference. The effect of this provides hinderance to the performance of system in case of finite number of users. But in large dimensioned system with the aid of extra DOF, it has overcome this problem. Further for providing more significant improvement in the system's performance using this technique, the power optimization is applied to the transmission schemes. Moreover, it does not require any particular planning scheme for addition and removal of service antennas at base station [48].

2. Zero Forcing (ZF) Beamforming Scheme

This scheme introduces the concept of cancellation of inter-user interference to the precoding of the system. It performs this by analysis of orthogonal component for each transmitted stream which is

further accomplished by usage of pseudo inverse which provides inversion to channel matrix and cancels out the interference. The equation of pseudo inverse for the system is given by [49].

$$W = H^*(H^T H^*)^{-1} \quad (3.18)$$

But this scheme does not consider the effect of noise which leads to degradation of the performance of the system.

Moreover, if the comparison has been made between the MRT and ZFBF scheme, then MRT outperforms the ZF one especially in hyper MIMO system due to the usage of extra service terminals. Also, the implementation of this MRT scheme is quite simpler as compare to the other [48].

3. Minimum Mean Squared Error (MMSE) Beamforming Scheme

As, the name suggest this scheme assist the system in minimization of the mean squared error between the receive signal at user end and transmitted one. Unlike ZF scheme, this MMSE considers the effect of noise as it depends upon the noise variance. Also, by adding some more modifications, it can be used in multicell scenarios for the removal of pilot contamination. Further, the implementation of this scheme has found to be slightly more complex than ZF one but with improved system performance. The precoding matrix of scheme is given as [57]

$$W = H^* \left(H^T H^* + \frac{K}{p_d} I_K \right)^{-1} \quad (3.19)$$

Further, if the performance of this scheme is compared with MRT scheme, then in case of massive MIMO systems the MRT still outperforms this MMSE scheme in terms of simplicity and performance due to extra DOF. As, here the main reason behind the rise in system complexity is the requirement of the knowledge of noise variance [48].

3.1.1.5 OFDM System

In case of the combine technology between massive MIMO and OFDM system, the OFDM system has been implemented with each service antenna of base station. Similarly, its respective decoder part is implemented with each antenna of user end. The implementation of encoder and decoder of the OFDM system gets reverse when it is implemented in instance of uplink transmission. Further, in the system diagram all the blocks after precoder and including also the modulation one is the part of OFDM scheme.

The details of various block used in OFDM system are:

Serial to Parallel (S/P) Converter

This converter is used to convert the serial data stream into N parallel streams so that IFFT operation can be applied on to the data stream. The number of parallel streams depends upon the number of subcarriers required or size of IFFT. Also, to these parallel data stream some pilot signals are adjusted in between for maintaining the synchronization, equalization and estimation at the receiver side.

IFFT Operation

In OFDM system, the conversion of data stream from frequency domain to time domain is accomplished by this operation. Primarily, this system superimposed the data on to the N-orthogonal subcarriers using the IFFT operation. The N-subcarriers are selected in such a way that each subcarrier is orthogonal to

other. Further due to the orthogonality, these subcarriers can easily overlap one another and increase the system efficiency. Also, the total subcarriers added, act as a guard band for another subcarrier and prevents ICI. With the use of the IFFT operation, the use of conventional N sinusoidal modulators and demodulators have been suppressed. As, the usage of these independent modulators, at transmitter and demodulators, at receivers lead to increment in the system complexity, size, cost and power consumption. Also, special care has been taken for maintaining the synchronization. So, with the usage of these fast Fourier algorithms all the conventional problems have been solved.

Parallel to Serial (P/S) Converter

After performing the IFFT operation the parallel sub streams are converted into a serial stream so that the addition of cyclic prefix can be done to the data stream.

Cyclic Prefix

This prefix is added to the data stream for making the length of the symbol greater than the delay spread caused by multipath propagation. In this, some specific length of the symbol from the last portion is again added to the fronts side which makes the OFDM symbol periodic in nature. The addition of this extra portion of length act as guard band for the symbol and prevents the system from the effect of ISI. Also, with the introduction of periodicity to the symbol, the effect of the multipath channel on the signal is converted to circular convolution due to which it becomes easy for the receiver to equalize it. In addition to cyclic prefix, windowing is also performed at the transmitter side for limiting the band width of the rectangular pulse of OFDM symbol. This windowing functionality primarily does not affect the data part of the symbol, rather it reduces the side lobes level and prevents the transmission of signal power out of band. Further it has been found that both the cyclic and prefix and windowing interval is neglected at the receiver and results into decrement in system's efficiency. As they are only used for providing reliable transmission without interference.

So, after processing the data stream from the transmitter side. The OFDM symbol can be represented mathematically as the sum of pulses which are shifted in time as well as in frequency along with multiplication with their respective data symbols. Further its representation for k th symbol is given by [11].

$$s_{RF,k}(t - kT) = \begin{cases} Re \left\{ w(t - kT) \sum_{i=-\frac{N}{2}}^{\frac{N}{2}-1} x_{i,k} e^{j2\pi \left(f_c + \frac{i}{T_{FFT}} \right) (t - kT)} \right\} \\ kT - T_{win} - T_{guard} \leq t \leq kT + T_{FFT} + T_{win} \text{ otherwise} \\ 0 \end{cases} \quad (3.20)$$

Where T represents the symbol length of OFDM symbol

T_{FFT} represents the time of FFT

T_{guard} represents the cyclic prefix duration

T_{win} represents the window interval

f_c represents the center frequency of the spectrum

N represents FFT length

k represents index on transmitted symbol

i represents index on subcarriers

$x_{i,k}$ represents signal constellation point

$w(t)$ represents the transmitted pulse shape

The equation representing the shape of transmitted pulse used in the system has been given as [11]

$$w(t) = \begin{cases} \frac{1}{2} [1 - \cos \pi(t + T_{win} + T_{guard}) / T_{win}] & -T_{win} - T_{guard} \leq t < -T_{guard} \\ 1 & -T_{guard} \leq t \leq T_{FFT} \\ \frac{1}{2} [1 - \cos \pi(t - T_{FFT}) / T_{win}] & T_{FFT} < t \leq T_{FFT} + T_{win} \end{cases} \quad (3.21)$$

Then combine representation of all OFDM symbols is shown as [11]

$$s_{RF}(t) = \sum_{k=-\infty}^{k=\infty} S_{RF,k}(t - kT) \quad (3.22)$$

At receiver side,

After receiving the data stream at the user terminal, all the processes and operations which are applied in some sequence to the transmitted streams at base station, is applied in same progression to the received stream at the user end. Therefore, first the removal of cyclic prefix is done and after that the data is converted to parallel form for applying it to the FFT operation. This converts the user data into frequency domain and then the serial stream achieved after processing it from parallel to serial converter is passed through demodulators and decoders for retrieving it in original form.

The received signal in case of channel with multipath propagation denoted as $h(t)$ is represented as [11]

$$r(t) = h(\tau, t) * s(t) + n(t) \quad (3.23)$$

$$r(t) = \int_0^{\tau_{max}} h(\tau, t) s(t - \tau) + n(t) \quad (3.24)$$

After applying FFT operation on the k th received symbol, its equation is given as [11]

$$y_{i,k} = \frac{1}{T_{FFT}} \int_{t=kT}^{kT+T_{FFT}} r(t) e^{-j2\pi i(t-kT)/T_{FFT}} dt \quad (3.25)$$

In all these inverse operations at receiver of user end, the main motive is to extract the original signal $x_{i,k}$ from received signal $r(t)$.

3.1.1.6 Radio Frequency (RF) Chain

These RF chains are associated with antenna terminals at both sides of transmitter and receiver system. It basically consists of Analog to Digital (A/D) or D/A converter, power amplifiers, filters and many other components that are required for transmission and reception of the signals.

3.1.1.7 Channel Model

In this work, for description of the channel conditions, Rayleigh channel model has been utilized in all stimulated systems. The delays associated with distinct multipath signals is measured and analysed statistically using the centre limit theorem. Primarily, the main purpose of this used theorem is the modelling of time variant impulse responses of wireless channel into gaussian random process. If this

modelled random process has zero mean value, then the given channel is considered as Rayleigh flat fading channel and is basically used for depiction of all non-line of sight signals. The pdf of this channel is represented as [2].

$$f(r) = z/\sigma^2 \exp(-z^2 / 2\sigma^2) \quad (3.26)$$

Here, z represents the envelope of the signal consisting of in-phase component i.e. r_I and quadrature component i.e. r_Q having the same variance value equal to σ^2 . The equation of z is given as [2]

$$z(t) = \sqrt{r_I^2(t) + r_Q^2(t)} \quad (3.27)$$

3.2 Uplink/MAC Transmission

In this process the K users transmit their data streams in the same time and frequency domain to base station. So, this transmission is reverse case of downlink one. Various number sum of streams from different user ends is received by the numerous service antennas at the base station site. These large arrays apply decoding process on the received streams depending upon the obtained CSI. The knowledge of CSI at base station assist the system in removal of inter user interference. Also, the theory of this uplink procedure quite resembles the process of that used in point-to-point MIMO system. Due to this, it becomes quite simpler to decode the signals and untangles them into separate user's data streams. The system model of this uplink system of MU Massive MIMO-OFDM has been depicted using Figure 3.5 In this model, the system is shown consisting of M service antennas and K user terminals with single antenna each. So, as discussed above in this system the base station site has been shown consisting of decoder block having access to channel information which plays a significant role in decoding of received streams from multiple users [40]. Therefore, the representation of received signal at the base station site is combination of all the data streams transmitted by K users. The mathematical representation of the received signal is shown as [57].

$$y_{ul} = \sqrt{p_u} \sum_{k=1}^K h_k s_k + n \quad (3.28)$$

Where average SNR is represented using p_u , s_k denotes the transmitted data vector from the k th user end and n represents the $M \times 1$ noise vector having gaussian distributed random variables. In simpler form the equation (3.26) can be represented as [57].

$$y_{ul} = \sqrt{p_u} H s + n \quad (3.29)$$

So, as described above H represents the channel matrix having dimension equal to $M \times K$.

Further, for decoding process of the signal at base station site in case of large dimensioned MIMO systems only linear detection schemes are used. As, with the usage of these linear schemes, the process of estimating the receive signals in the presence of large antenna arrays becomes easier in comparison to others. Due to this, the linear techniques which provides less accurate performance than non-linear ones become an optimal technique along with providing less system complexity [40].

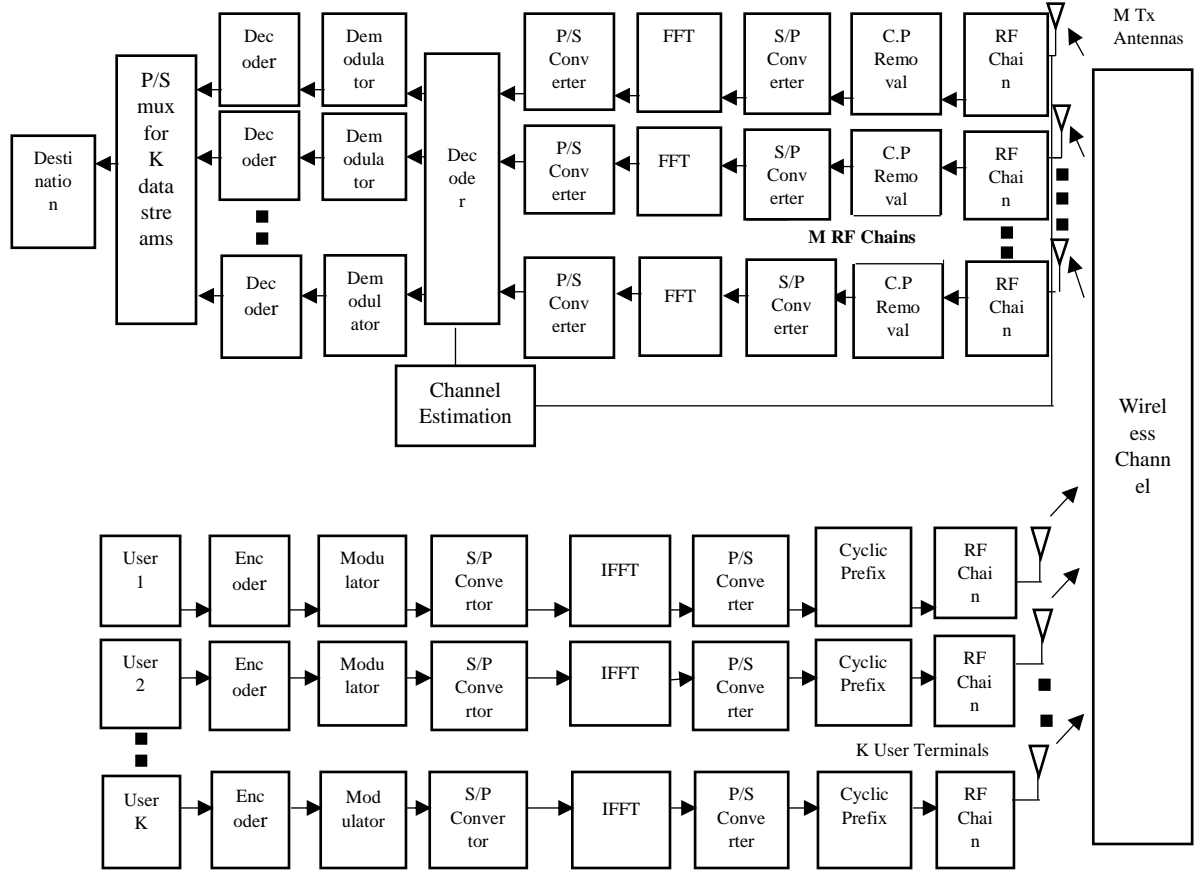

Figure 3.5 Block Diagram of MU Massive MIMO-OFDM System for Uplink Transmission

In this work, all the models based on uplink transmission have used ZF receiver for decoding the data. The equation representing the decoder matrix ‘A’ having dimensions equal to $M \times K$ used at base station site is given as [57]

$$\tilde{y}_{ul} = A^H y_{ul} \quad (3.30)$$

This equation can be further written as [57]

$$\tilde{y}_{ul} = \sqrt{p_u} A^H H s + A^H n \quad (3.31)$$

Each data stream transmitted by different users is separated from the combine received signal. This distinct decoded stream corresponding to each user consist of required data signal along with inter-user interference and noise. The representation of each kth stream of user after decoding process is given as [57].

$$\tilde{y}_{ul,k} = \sqrt{p_u} a_k^H h_k s_k + \sqrt{p_u} \sum_{k' \neq k}^K a_k^H h_{k'} s_{k'} + a_k^H n \quad (3.32)$$

3.2.1 Receiver Schemes Used in Uplink Transmission

Further, the generally used linear receivers in case of hyper MIMO systems are:

1. Maximum Ratio Combining (MRC) Receiver
2. Zero Forcing Receiver (ZF)
3. Minimum Mean Square Error (MMSE) Receiver

Most of the properties of these receivers are similar to the same approaches used in precoders in downlink transmission.

1. Maximum Ratio Combining (MRC) Receiver

This approach works on the principle of maximizing the SNR value for each received data stream from multiple users. In terms of implementation this scheme works in a very simple way. It separates the distinct data streams from different users by just multiplying the received signal with the conjugate transpose of H represented as [57]

$$A^H = (H^*)^H \quad (3.33)$$

As described above, these maximum ratio techniques only focus on maximizing energy but does not consider the effect of inter-user interference [57].

2. Zero Forcing (ZF) Receiver

In this scheme the main focus lies on complete cancellation of inter user interference by using the approach of projection of the user data stream in the direction of orthogonal complement to that of interference among multiple users. The decoder matrix for this transmission is given by applying pseudo inverse of channel matrix H [57].

$$A^H = (H^H H)^{-1} H^H \quad (3.34)$$

But, this receiver does not consider the effect of noise in detection. Also, with the implementation of pseudo inverse the noise in the signal gets more amplified which leads to degradation in the system performance.

3. Minimum Mean Square Error (MMSE) Receiver

The aim of this receiver is to decrease the mean square error between the detected and actual transmitted data signal. The computation complexity of this technique is comparatively more than that of ZF one. But this cost of complexity is paid off in terms of improved performance. The formula for decoding the receive signal using this technique is given as [57]

$$A^H = (H^H H + \frac{I_K}{p_u})^{-1} H^H \quad (3.35)$$

Further, to find out the achievability rate for the MAC transmission system using different precoding schemes, first the SINR of each received stream from different users is find out at receiver using the formula given as [57]

$$SINR_k = \frac{p_u |a_k^H h_k|^2}{p_u \sum_{k' \neq k}^K |a_k^H h_{k'}|^2 + \|a_k\|^2} \quad (3.36)$$

Then, this computed $SINR_k$ from different users in the system is used in the formula for finding out the total sum rate achieved given by the equation [57]

$$R = \sum_{k=1}^K E\{\log_2(1 + SINR_k)\} \quad (3.37)$$

The RF chains, FEC coding technique and OFDM modulation used in the uplink transmission is almost same as downlink one, only the location of OFDM precoder and decoder has been change depending upon the transmitter and receiver used in this case.

3.3 Coded MU Massive MIMO-OFDM System with Hybrid Beamforming Scheme for Broadcast Transmission

The implementation of conventional linear beamforming schemes in instance of realistic scenarios especially in case of hyper MIMO systems is impractical. This is because each antenna in this system requires the use of a dedicated RF chain, as each data stream which is to be transmitted from these large arrays need to be processed at its base band level. The whole procedure of the processing technique involves the modifications in the amplitudes along with phases of the symbols to be transmitted in data streams. Then these modified streams are to be passed through D/A convertors, mixers and in the last from power amplifiers in RF chain. Then these signals from RF chains are upconverted over the carrier frequency and are eventually coupled to service antennas for transmission. Therefore, with the usage and maintenance of such large number of components for each service antenna lead to increment in the cost and system complexity. Due to this, these large dimensional systems require the usage of a hybrid scheme in case of practical environments which could work similar to conventional precoding schemes in the situation of limited hardware and does not put any constraints in the growth of antennas array of these massive systems [52].

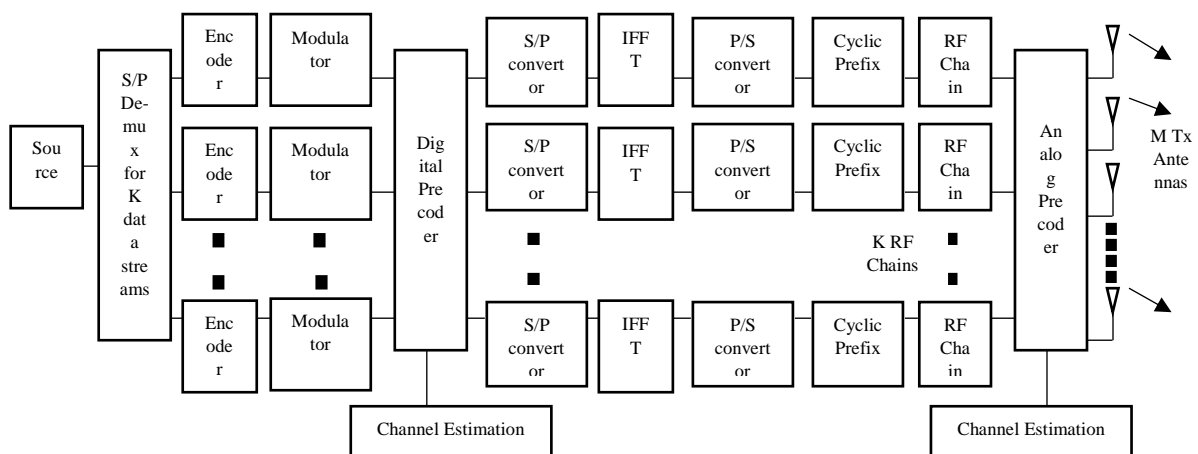

Figure 3.6 Block diagram of base station site of MU Massive MIMO-OFDM System with Hybrid Beamforming Scheme

So, to overcome the problem of usage of large number of components in implementing these massive antenna systems various number of hybrid schemes have been introduced. In this work, the system design has been based on the phased zero-forcing (PZF) hybrid beamforming scheme. Primarily with the usage of these schemes the precoder block at system base station is split into two parts. In first segment the low -dimensional digital precoding is performed on the data streams in baseband domain and after this these streams are modified using high dimensional analog precoders. This high dimensionality in analog precoders does not affect the cost and complexity of the system. As, it includes only phase precoding in this part, which is easily achieved using inexpensive variable phase shifters. So, with the usage of combination of these two precoders, the hybrid schemes assist in practical implementation of the massive MIMO systems for both the frequency bands i.e. sub 6GHz and mm-Wave band [52]. Figure 3.6 represents the block diagram of the base station site of MU MIMO-OFDM

System with Hybrid Beamforming technology. This model basically depicts the concept of PZF with only k number of RF chains utilized in transmission [51].

The PZF used in this work, applies low-dimensional ZF scheme at digital precoder stage. Due to this it limits the usage of large number of RF chains. So, for performing the digital precoding first the phases of conjugate transpose of aggregated broadcast channel is analysed with the aid of channel reciprocity applied on the uplink pilots receive in TDD mode of the system. These phases are basically extracted for designing the RF precoder and estimating the large array gain of this hyper MIMO system. The equation denoting the RF precoder F having dimension which is responsible for regulation of phases of the upscaled data streams of K users in the system is given as [51]

$$F_{i,j} = \frac{1}{\sqrt{M}} e^{j\varphi_{i,j}} \quad (3.38)$$

Where $F_{i,j}$ denotes the (i,j) th element of the analog precoder F and $\varphi_{i,j}$ denotes the phase of the conjugate transpose of the estimated channel matrix H^T .

Then based on the multiplication of the RF precoder F and estimated channel matrix H^T for downlink transmission, a new equivalent channel matrix has been derived represented as H_{eq} [51].

$$H_{eq} = H^T F \quad (3.39)$$

Here, the dimension of this H_{eq} is $K \times K$, which is lower than the actual channel matrix H having dimensions equals to $M \times K$ used in full complex ZF precoding scheme.

Then this new equivalent channel matrix H_{eq} is used to derive the equation for low complexity ZF precoder denoted as W , given by [51]

$$W = H_{eq}^H (H_{eq} H_{eq}^H)^{-1} \Lambda \quad (3.40)$$

Here, for normalizing the column power of the precoding matrix W , a diagonal matrix Λ is introduced. The representation of combined received signal at K user terminals sent using PZF beamforming approach is given as [51]

$$y = \sqrt{\alpha p_d} H^T F W q + z \quad (3.41)$$

Where q represents combined vector of data streams and z denotes the AWGN.

Using the above equations, this system uses only K RF chains for transmitting of data streams to K single antenna users in MU Massive MIMO systems, which makes it practical implementation possible [51].

For implementation of coded MU Massive MIMO-OFDM downlink system with hybrid beamforming scheme all other parts at base station such as FEC Coder and OFDM modulator remains same as in case of conventional system. Only the changes are made in number of RF chains and precoding scheme.

CHAPTER 4

RESULTS & DISCUSSIONS

In this chapter, the results are divided into two parts. In the first section the comparison of the BER and achievability rates of the MIMO-OFDM, MU MIMO-OFDM and MU Massive MIMO-OFDM system have been made and discussed for both broadcast and MAC transmission cases. Then, in the second part the concept of PZF hybrid beamforming scheme is introduced in the downlink transmission and its comparison is evaluated against ZF beamforming scheme. The comparisons between linear and hybrid beamforming schemes have been made particularly on the basis of different parameters, specifically BER, achievability rate and complexity in computation time. Moreover, these comparisons between the diverse beamforming schemes is evaluated in presence of FEC codes. Therefore, two different FEC codes i.e. Convolutional code and R-S code are added to the downlink system and their performances is being analysed in relation with the un-coded one.

4.1 Comparison of the MIMO Technologies

For the comparison of the MIMO technologies that are evolve with time, three system models are considered in Rayleigh fading channel conditions. The first system model consists of point to point MIMO-OFDM system containing 4 transmit and 4 receive antennas. The second model used in this work is of MU MIMO-OFDM system having 8 service antennas and 4 single antenna user terminals and third one is of MU Massive MIMO-OFDM system in which there is being great inflation in number of service antennas at base station site as compare to the earlier MIMO approaches, here the number considered is 128 with 4 single antenna user ends. In all these models used in this work, ZF scheme along with OFDM modulation has been utilized. The OFDM technique used here, is based on IEEE 802.11a standard consisting of 64-point FFT along with QPSK modulation. Out of these 64 available subcarriers placed 312.5kHz apart, only 52 are utilized for carrying data and the rest of them are employed as pilot and null subcarriers for avoiding the offsets and attenuation in the system respectively [12]. Further, the knowledge of perfect CSI has been assumed at receiver end in case of point-to-point MIMO system and at the base station site for the case of all MU MIMO systems.

4.1.1 Error Rate Performance

For measurement of error rate performance of various MIMO-OFDM schemes, the graph of BER as a function of SNR has been plotted. Figure 4.1 and 4.2 represents the BER verses SNR (dB) for different MIMO-OFDM technologies for both the cases of downlink and uplink transmission respectively. With the simulations of the error rates for these various MIMO-OFDM systems it has been proved that as the number of service antennas at the base station site is being increased in relative to the receiver terminals, the performance of the system in terms of error rate is enhanced. This is primarily because of raise in extra DOF which leads to further accretion in diversity and multiplexing gain of the system. As, in case of broadcast transmission in Figure 4.1 at 0.01 BER achieved, the SNR required for 4x4 MIMO-OFDM

system is 9dB, 8X4 MU MIMO-OFDM system is 4dB and 128x4 MU Massive MIMO-OFDM system is -3.8dB and for the case of MAC transmission in Figure 4.2 at 0.01 BER achieved, the value of SNR required for 4x4 MIMO-OFDM system is 8.9dB, 8x4 MU MIMO-OFDM system is 1dB and 128x4 MU Massive MIMO-OFDM system is -6.9dB. In addition to this, from the comparisons made between two different transmission processes i.e. for downlink and uplink systems in figure 4.1 and 4.2 respectively, it is observed that the SNR required for a particular value of BER especially for multiuser MIMO system for uplink case is comparatively less than that for downlink one. The reason for this less error rate in uplink case is the knowledge of CSI at the base station site which assist the system in removal of inter-user as well as channel interferences. So, the performance of the uplink system outperforms that of downlink one despite the usage of numerous precoding techniques.

System Model	SNR (in dB) at 0.01 BER	
	Downlink	Uplink
Point-to-Point MIMO-OFDM System	9	8.9
MU MIMO-OFDM System	4	1
MU Massive MIMO-OFDM System	-3.8	-6.9

Table 4.1 SNR values for Downlink and Uplink Transmissions of different MIMO-OFDM Systems at 0.01 BER

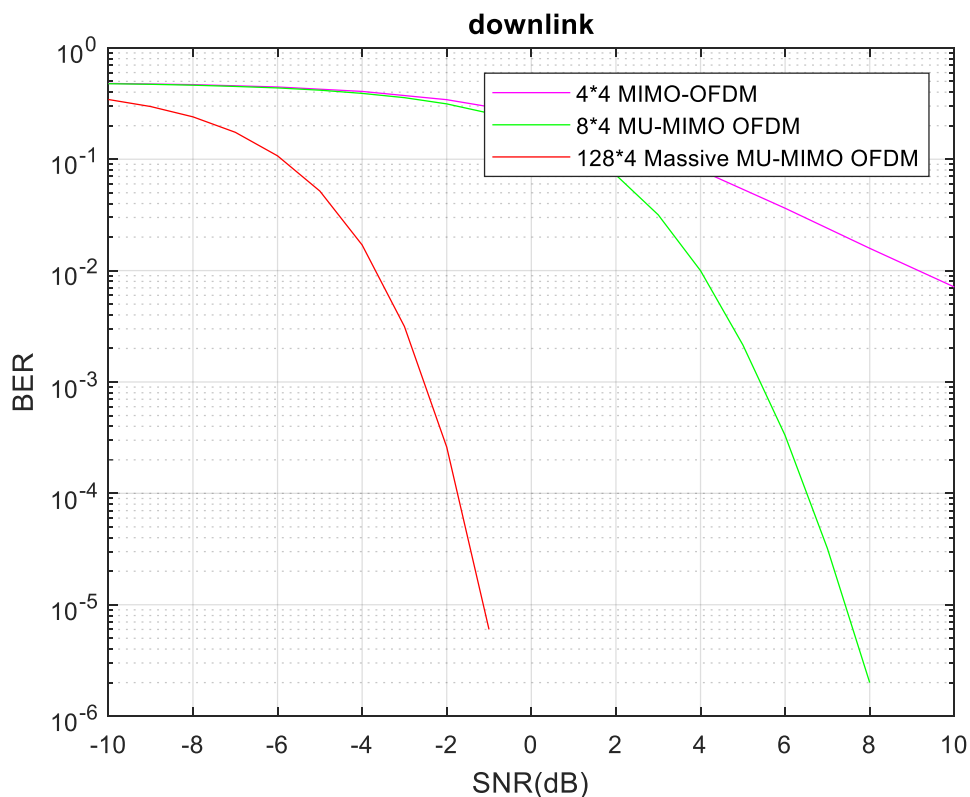

Figure 4.1 BER versus SNR (dB) for Downlink System Model of MIMO-OFDM, MU MIMO-OFDM and MU Massive MIMO-OFDM systems

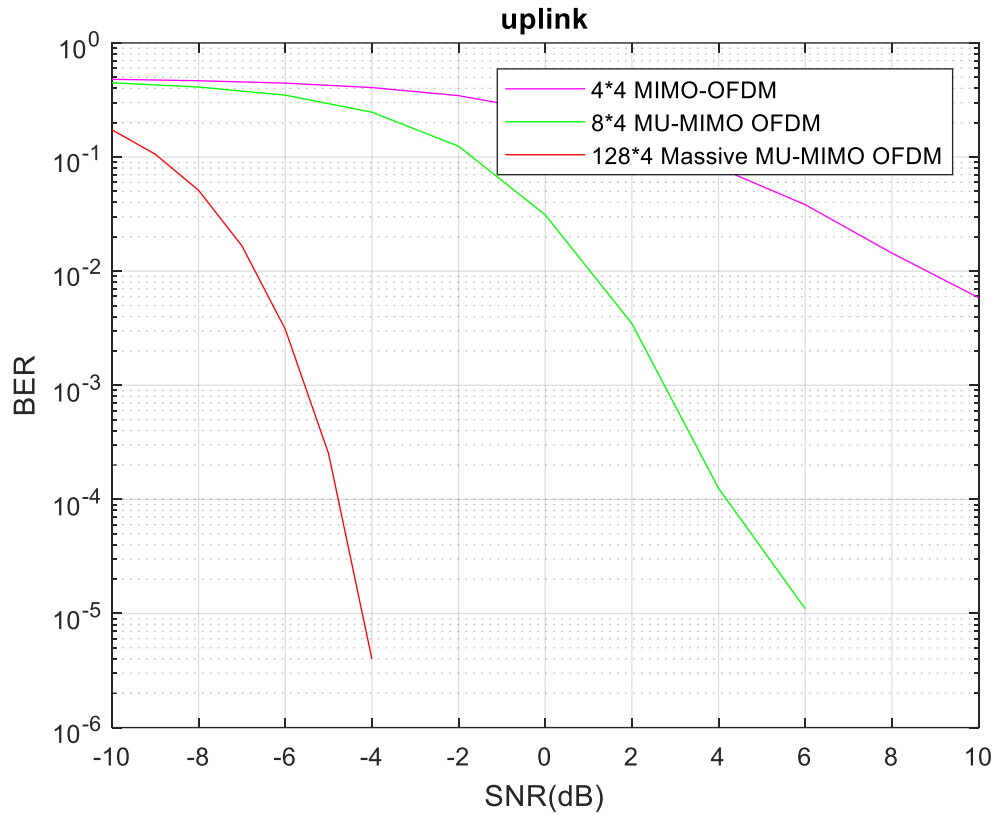

Figure 4.2 BER verses SNR (dB) for Uplink System Model of MIMO-OFDM, MU MIMO-OFDM and MU Massive MIMO-OFDM systems

4.1.2 Achievability Rate Performance

This parameter is primarily used for evaluation of achievability rate of the system with respect to the SNR. The rates achieved with these distinct MIMO technologies depends upon the various system parameters such as interference, error rates, number of antennas and many other factors. Figure 4.3 and 4.4 represents the plot of achievable rate as a function of SNR (dB) for various MIMO-OFDM technologies in case of both downlink and uplink transmissions respectively. It is being observed from the derived simulations depicted in these figures, that for same number of multiple active users in the system, the MU Massive MIMO-OFDM system leads to the huge increment in the rate achieved as compare to the other schemes. Particularly, the main reason behind this immense raise is the usage of large antenna arrays at base station site in comparison to antennas use at multiple user terminals. From simulations in Figure 4.3 and 4.4, the enhancement achieved in the rate of the system with increasing antennas has been proved and depicted statistically. As in instance of figure 4.3 for downlink case at 20dB SNR, the rate achieved for 4x4 point-to-point MIMO-OFDM system is 10 bits/sec/Hz, 8X4 MU MIMO-OFDM system is 25 bits/sec/Hz and 128X4 MU Massive MIMO-OFDM system is 43bits/sec/Hz and for uplink case in figure 4.4 at 20dB SNR, the rate achieved for 4x4 point-to-point MIMO-OFDM system is 10 bits/sec/Hz, 8X4 MU MIMO-OFDM system is 40 bits/sec/Hz and 128X4 MU Massive MIMO-OFDM system is 60 bits/sec/Hz. Further, the result presented in the work [51] for spectral efficiency achieved for case of MU MIMO system has been taken as a reference for the

achievable rate achieved in figure 4.3 for MU massive MIMO-OFDM system. Further, on comparison of these systems in the presence of different transmissions modes i.e. for the cases of uplink and downlink schemes, it is again proved that the performance of uplink surpasses the downlink one due to the availability of CSI at the base station sites.

System Model	Achievability rate (in bits/sec/Hz) at 20dB SNR	
	Downlink	Uplink
Point-to-Point MIMO-OFDM System	10	10
MU MIMO-OFDM System	25	40
MU Massive MIMO-OFDM System	43	60

Table 4.2 Achievability Rate values for Downlink and Uplink Transmissions of different MIMO-OFDM Systems at 20dB SNR

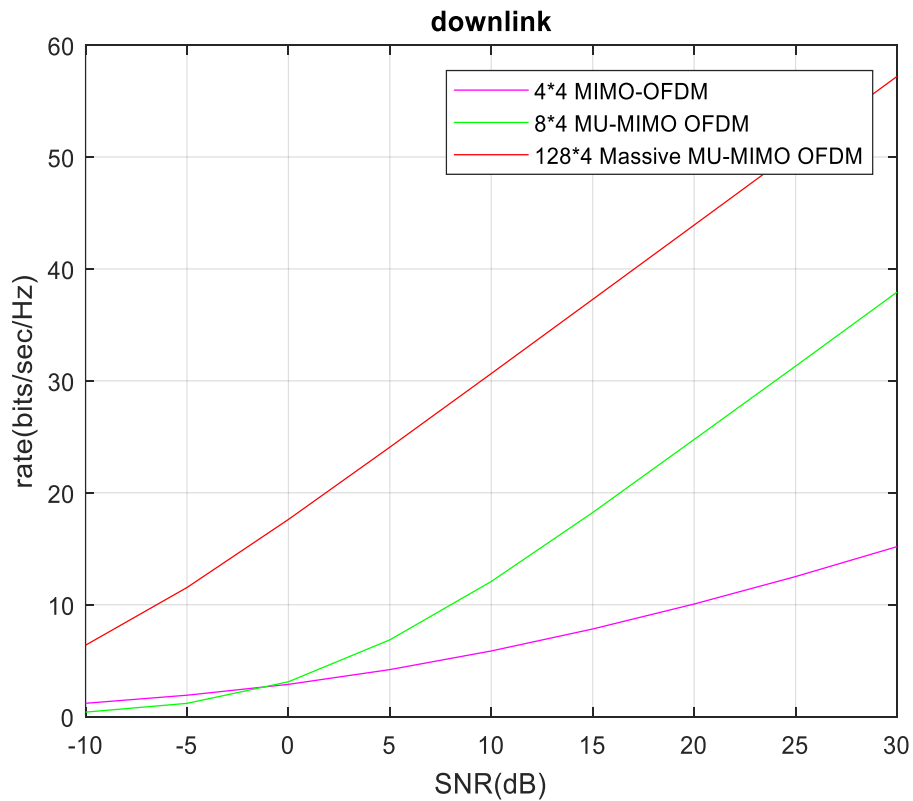

Figure 4.3 Achievability rate versus SNR (dB) for Downlink System Model of MIMO-OFDM, MU MIMO-OFDM and MU Massive MIMO-OFDM systems

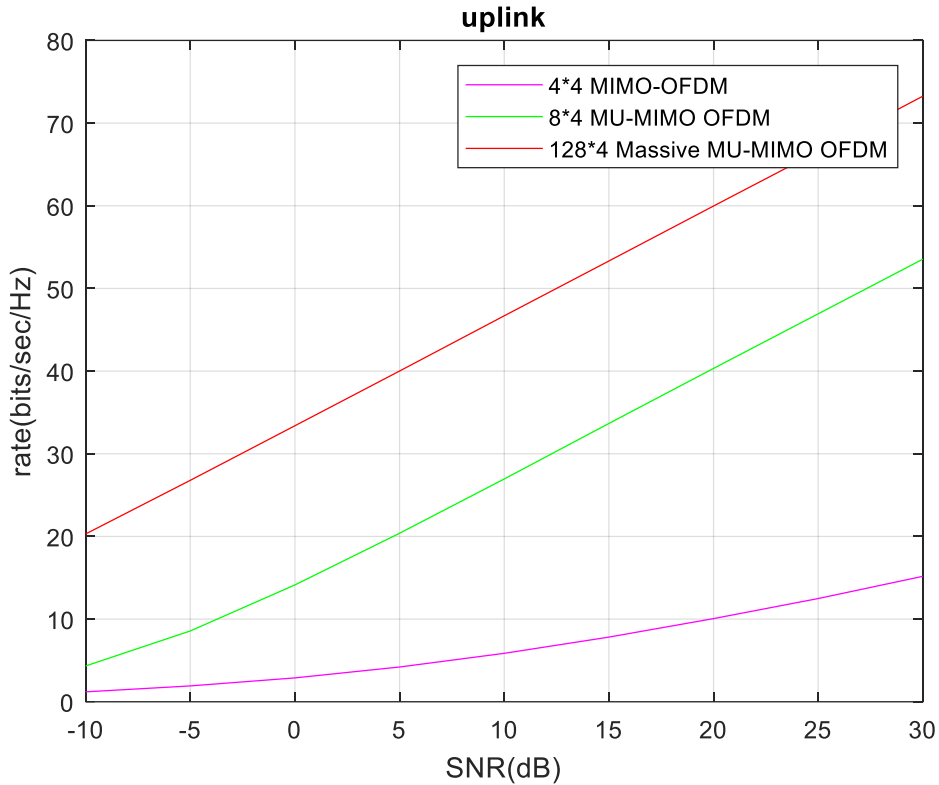

Figure 4.4 Achievability rate versus SNR (dB) for Uplink System Model of MIMO-OFDM, MU MIMO-OFDM and MU Massive MIMO-OFDM systems

4.2 Comparison of ZF and PZF Hybrid Beamforming Schemes in Presence of Both Coded and Un-coded Systems

In this segment the performance of PZF hybrid beamforming scheme is analysed relative to the highly complex ZF beamforming. For carrying out this evaluation process for the used hybrid scheme, its performance is being measured and compared with that of ZF for three distinct parameters. These three parameters are BER, achievability rate and computation complexity. The system model used for these comparisons of various parameters for different precoding schemes is based on broadcast transmission of MU Massive MIMO-OFDM system in Rayleigh fading channel model, consisting of 128 service antennas and 20 single antenna user ends. Further with each of the RF chain used in the system, OFDM technique has been integrated with it for avoiding ISI and enhancement in system performance. The OFDM system used here, is assumed to be based on IEEE 802.11a wireless standard having 64-point FFT size. So, this used technique in total provides 64-subcarriers placed 312.5KHz apart for transmission purpose. But not all the subcarriers are used for data transmission, only 52 are utilized in this case and the rest 12 are used for either carrying the pilot signals which are used in maintaining synchronization or are kept null for avoiding the effect of attenuation from the filters [12]. In the system model used, before the processing of data in precoder block each data stream to be transmitted is modulated using the QPSK scheme. In addition to this, all these comparisons based on numerous

parameters for hybrid and linear precoding schemes is also computed for two different FEC codes i.e. R-S code and convolutional code. Then the comparisons between these distinctly coded and un-coded systems are also evaluated for examining the system performance.

4.2.1 Error Rate Performance

This parameter is used for analysing the system BER as a function of SNR. Figure 4.5, 4.6 and 4.7 illustrates the graphs for system's BER performance verses SNR (dB) for MU Massive MIMO-OFDM systems using ZF and PZF hybrid beamforming schemes for un-coded data streams, (1/2) rate convolutional coded data streams and (31,27) R-S coded data streams respectively. From all these derived results, it is proved that the used PZF hybrid scheme performs almost equivalent to that of fully digital ZF technique with loss nearly equal to 1dB in system's performance. This meagre loss in system performance with PZF beamforming approach is reimbursed in the form of reduced hardware and less complex system. In addition to this after performing the evaluation process of these figures, it is noticed that in figure 4.5 at 0.001 BER the SNR required by ZF scheme is 1.2dB whereas for PZF scheme is 2.5dB, for figure 4.6 at 0.001 BER the SNR required by ZF scheme is -0.5dB whereas for PZF scheme is 0.8dB and for figure 4.7 at 0.001 BER the SNR required by ZF scheme is 0.8dB whereas for PZF scheme is 2dB. These given results from the derived simulations shows that as the system is moved from un-coded to coded data streams there is a significant improvement in the system's performance. Especially in case of convolutional FEC codes, the performance achieved is much better than that of Reed Solomon FEC codes. This is because these convolutional codes are specially designed for the elimination of random errors from the system whereas the Reed Solomon codes are expertise in eradicating burst errors.

Beamforming Schemes	SNR (in dB) at 0.001 BER for different Systems		
	Un-Coded	(1/2) Rate Convolutional Coded	(31,27) R-S Coded
ZF Scheme	1.2	-0.5	0.8
PZF Hybrid Scheme	2.5	0.8	2

Table 4.3 SNR values for Un-coded, Convolutional Coded, R-S coded MU Massive MIMO-OFDM Systems with different Beamforming Schemes at 0.001 BER

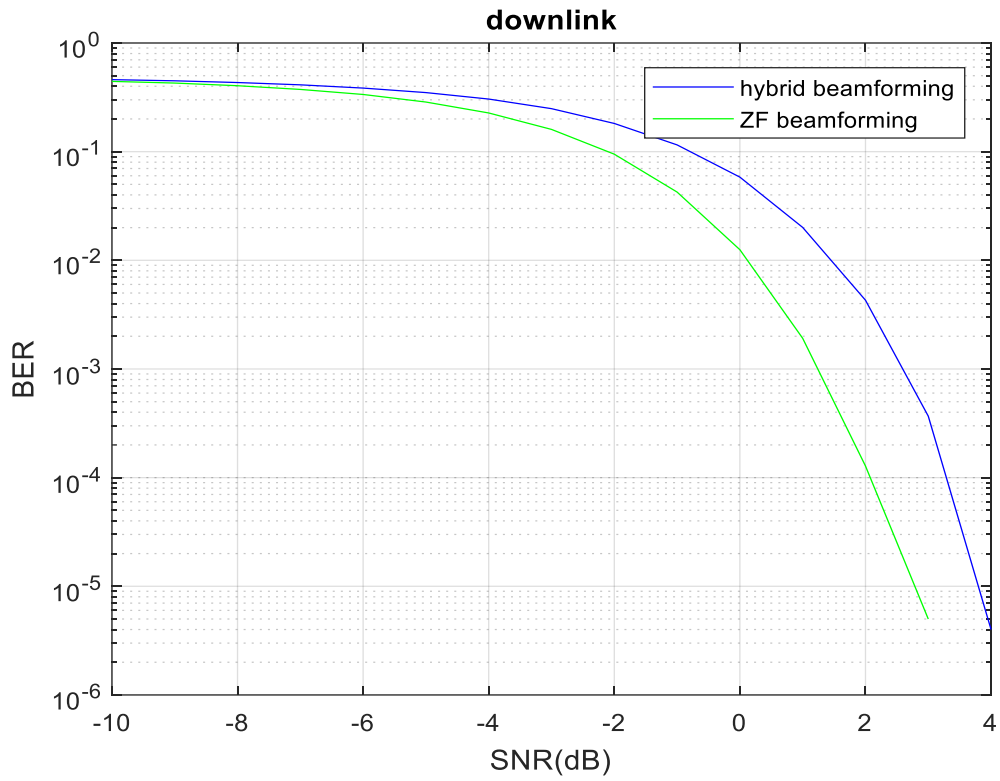

Figure 4.5 BER versus SNR (dB) for Un-coded MU Massive MIMO-OFDM system with $M=128$ service antennas and $K=20$ user terminals for ZF and PZF beamforming schemes

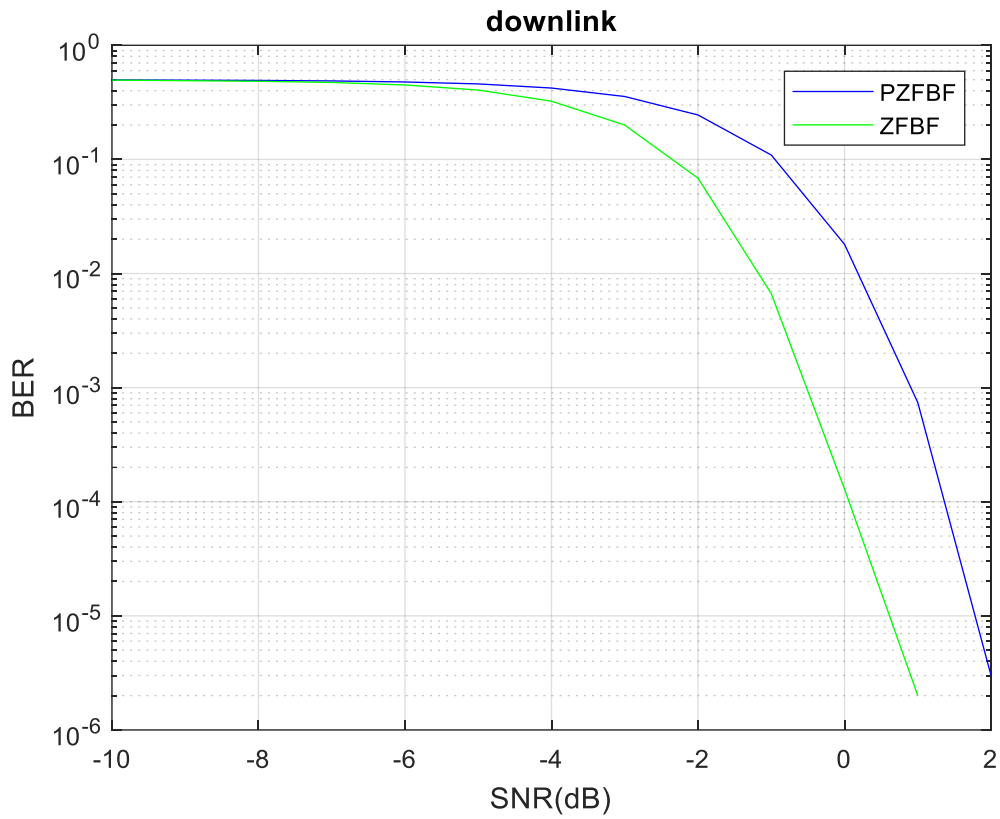

Figure 4.6 BER versus SNR (dB) for (1/2) rate Convolutional Coded MU Massive MIMO-OFDM system with $M=128$ service antennas and $K=20$ user terminals for ZF and PZF beamforming schemes

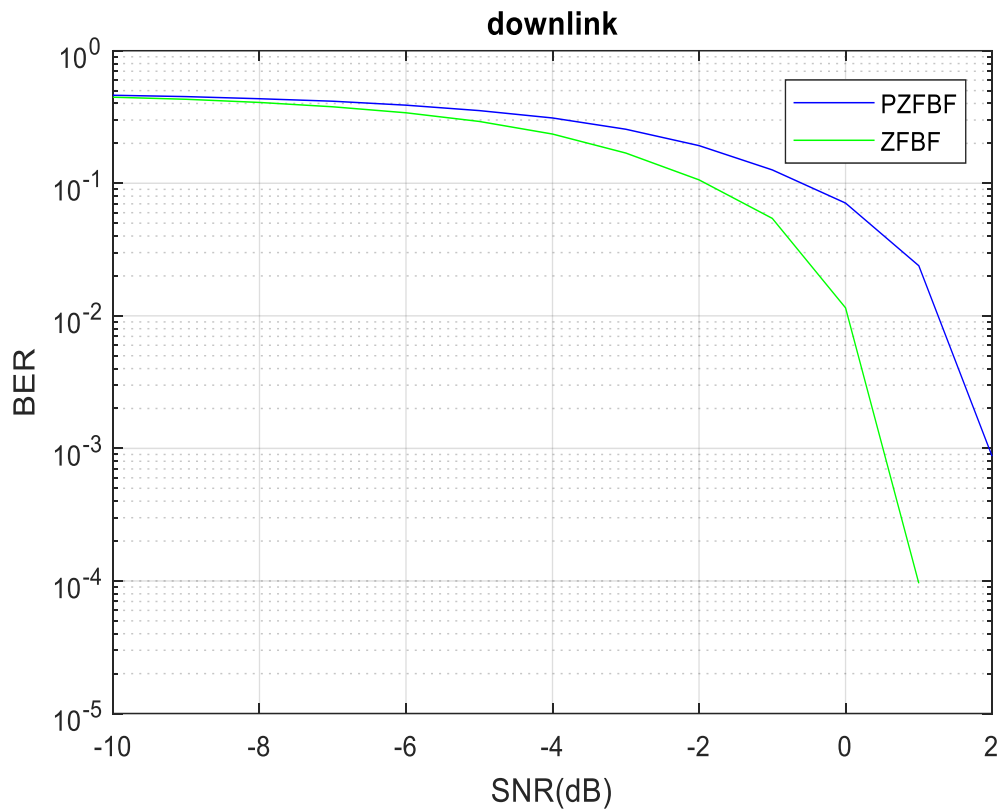

Figure 4.7 BER versus SNR (dB) for (31,27) Reed-Solomon Coded MU Massive MIMO-OFDM system with $M=128$ service antennas and $K=20$ user terminals for ZF and PZF beamforming schemes

4.2.2 Achievability Rate Performance

This parameter measures the maximum rate achieved by the system as a function of SNR. Figure 4.8 depicts the plot of achievable rate of the system versus SNR (dB) for MU massive MIMO-OFDM system with ZF and PZF beamforming schemes. The evaluation of the derived simulations represented in the given figure shows that the achievable rate plot of PZF scheme is almost approachable to that of ZF one. As, it is observed that for achieving the rate equal to 60 bits/sec/Hz the SNR required in case of ZF scheme is 3dB whereas in case of PZF scheme to achieve the same rate the SNR required is 5.5dB. So, this shows that there is an additional requirement of SNR in PZF scheme in comparison to that of ZF for obtaining the same rates. This necessity of increased SNR in hybrid scheme is compensated in the form of cost effective practically viable low dimensional ZF system.

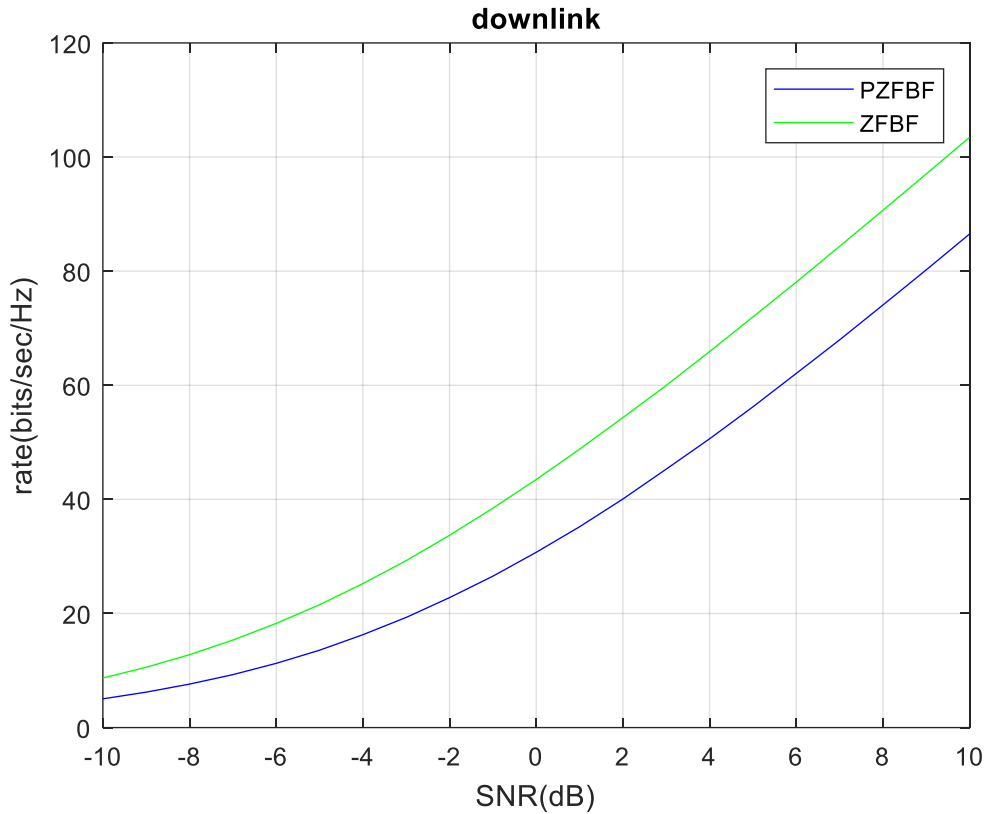

Figure 4.8 Achievability rate versus SNR (dB) for MU Massive MIMO-OFDM system with $M=128$ service antennas and $K=20$ user terminals for ZF and PZF beamforming schemes

4.2.3 Computational Complexity Analysis

This parameter measures the time consumption involves in computation of the system processing as a function of service antennas. So, primarily it carries out the assay of time requirement in sending the data from transmitter to the acquisition of data at receiver end of user terminals for MU Massive MIMO-OFDM system based on linear and hybrid beamforming schemes. Figure 4.9, 4.10 and 4.11 depicts the plots representing the total time consumed (in seconds) verses service antennas used, at a constant number of user terminals ($K=20$) present in the system for un-coded data streams, (1/2) rate convolutional coded data streams, (31,27) R-S coded data streams respectively. From the analyzation of these derived simulations, it is observed that there is an enormous decrement in time requirement for the computation of system with PZF scheme than that of highly complex ZF one. In addition to this, it is also examined that this benefit of reduced complexity is more beneficial to the system at higher number of service antennas rather than at lower ones. As, for the instance of 600 service antennas, the computational time required for un-coded system in figure 4.9 for ZF scheme is 640 seconds and for PZF scheme is 250 seconds, for (1/2) rate convolutional coded system in figure 4.10 for ZF scheme is 1050 seconds and for PZF scheme is 420 seconds, for (31,27) R-S coded system in figure 4.11 for ZF scheme is 7030 seconds and for PZF scheme is 6060 seconds and for the case of 200 service antennas, the requirement in time for un-coded system in figure 4.9 for ZF scheme is 70 seconds and for PZF scheme is 50 seconds, for (1/2) rate convolutional coded system in figure 4.10 for ZF scheme is 130 seconds and for PZF scheme is 90 seconds, for (31,27) R-S coded system in figure 4.11 for ZF scheme

is 2400 seconds and for PZF scheme is 2200 seconds. So, this obtained evaluation shows that for large number of service antennas i.e. for the case of 600 antennas present in the system there is a great difference exists between the time consumed values of ZF and PZF technique. But its value in instance of 200 service antennas reduces to meagre difference relative to that of case of 600 antennas. Therefore, this hybrid scheme is more valuable and efficient in Massive MIMO systems containing large number of antennas. Moreover, these results also simultaneously examine the performance of the system in the presence of various FEC codes which shows that as the system is moved from un-coded to convolutional coded to R-S coded data streams, a great increment in system complexity has been noticed.

Beamforming Schemes	Time consumption (in seconds) for 600 service antennas		
	Un-Coded	(1/2) Rate Convolutional Coded	(31,27) R-S Coded
ZF Scheme	640	1050	7030
PZF Hybrid Scheme	250	420	6060

Table 4.4 Time Consumption values for Un-coded, Convolutional Coded, R-S coded MU Massive MIMO-OFDM Systems at 600 service antennas with different Beamforming Schemes

Beamforming Schemes	Time consumption (in seconds) for 200 service antennas		
	Un-Coded	(1/2) Rate Convolutional Coded	(31,27) R-S Coded
ZF Scheme	70	130	2400
PZF Hybrid Scheme	50	90	2200

Table 4.5 Time Consumption values for Un-coded, Convolutional Coded, R-S coded MU Massive MIMO-OFDM Systems at 200 service antennas with different Beamforming Schemes

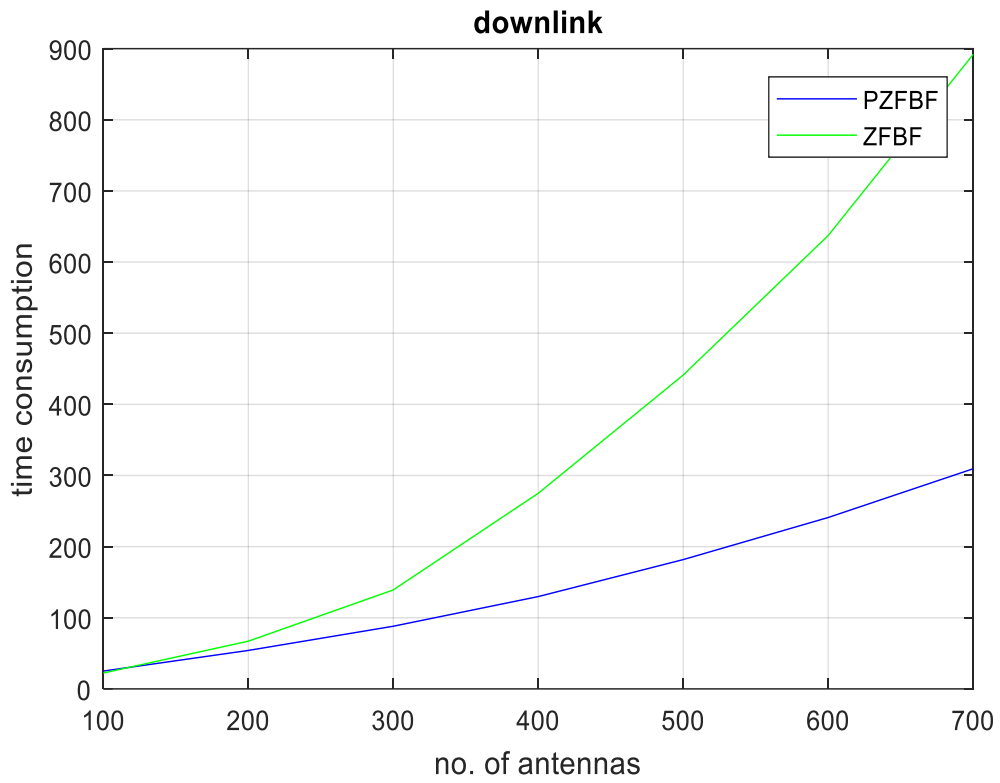

Figure 4.9 Time (in seconds) verses service antennas with constant number of user terminals $K=20$ for Un-coded MU Massive MIMO-OFDM system with ZF and PZF beamforming schemes

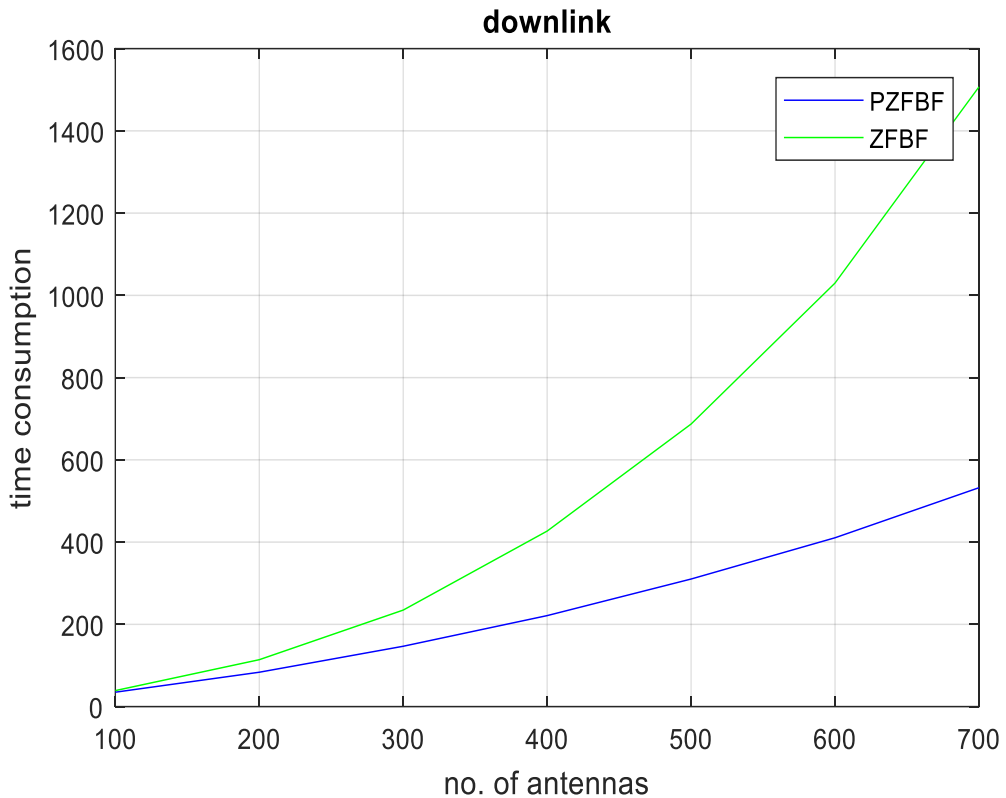

Figure 4.10 Time (in seconds) verses service antennas with constant number of user terminals $K=20$ for (1/2) rate Convolutional Coded MU Massive MIMO-OFDM system with ZF and PZF beamforming schemes

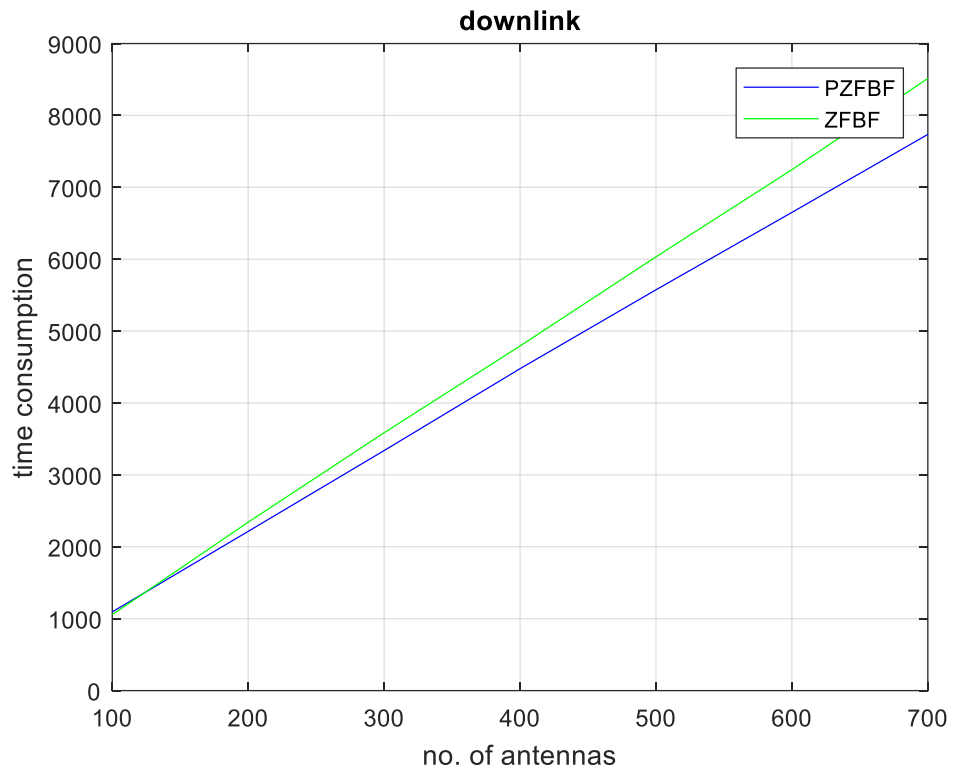

Figure 4.11 Time (in seconds) versus service antennas with constant number of user terminals $K=20$ for (31,27) Reed-Solomon Coded MU Massive MIMO-OFDM system with ZF and PZF beamforming schemes

CHAPTER 5

CONCLUSION AND FUTURE SCOPE

5.1 Conclusion

In this thesis, the work done has been segmented into two main parts. In the first part the comparative analysis of all the MIMO technologies integrated with OFDM scheme is being evaluated using the error rate and achievability rate parameters of the system for both the cases of broadcast and MAC transmissions. From the simulations performed for these approaches, it is revealed that as the system is shifted from point-to-point MIMO-OFDM system to MU MIMO-OFDM system and finally to MU Massive MIMO-OFDM system, a significant improvement has been noticed in the results. As, shown in figure 4.1 for downlink case at 0.01 BER, the SNR required for 4x4 MIMO-OFDM system is 9dB, for 8X4 MU MIMO-OFDM system is 4dB and for 128x4 MU Massive MIMO-OFDM system is -3.8dB and for the same transmission case the achievability rate acquired by the various systems is represented in figure 4.3 which shows that at 20dB SNR, the rate achieved for 4x4 point-to-point MIMO-OFDM system is 10 bits/sec/Hz, for 8X4 MU MIMO-OFDM system is 25 bits/sec/Hz and for 128X4 MU Massive MIMO-OFDM system is 43 bits/sec/Hz. This remarkable progress in the system's performance is primarily due to the usage of extra service antennas at base station site. So, these enlarged number of antennas at transmitter site, provides extra DOF which are utilized in improving the system efficiency, diversity and multiplexing gain. Further, on comparison of these two distinct transmission processes, it has been observed that uplink process performs better than that of downlink one. This is basically due to the presence of knowledge of CSI at base station site which cancels out the effect of inter-user interference from the received data streams.

In the second segment of this work the performance of the large dimensioned MU MIMO-OFDM system for downlink case is compared for two distinct beamforming schemes. This involves the comparison of fully digital ZF linear precoding scheme to that of PZF hybrid scheme. The comparison between these two is evaluated in terms of error rate, achievability rate and computational complexity parameters. From the derived simulations for the case of BER and achievability rate shows that this hybrid scheme performs almost equivalent to that of fully digital ZF scheme only with a small loss in system's performance. As, shown in figure 4.5 for un-coded case at 0.001 BER the SNR required by ZF scheme is 1.2dB whereas for PZF scheme is 2.5dB and for the case of achievability rate shown in figure 4.8 for achieving rate of 60bits/sec/Hz the SNR required in case of ZF scheme is 3dB whereas in case of PZF scheme to achieve the same rate the SNR required is 5.5dB. This small deficit in performance of PZF scheme is reimbursed in the form of reduced system complexity with the usage of less number of RF chains which made the system more economical and practical to implement. Further, with the simulations derived for the complexity parameter, the reduction in system's complexity has been proved practically which shows that the computational time required for 600 service antennas at base station for ZF scheme is 640 seconds whereas for PZF scheme is 250 seconds. So, this represents a considerable difference between the time required for implementation of these two distinct precoding

schemes. In addition to these results, some more comparisons have been added to the system on the basis of FEC codes. On comparison of these coded systems with that of un-coded one, an accretion in the system performance has been observed but at the cost of raised computation complexity. This raised complexity has been proved by the results obtained in figures 4.9, 4.10 and 4.11, that for the instance of 600 service antennas for PZF scheme used in the system, the time required for computation by un-coded system is 250 seconds, for Convolutional coded system is 420 seconds and R-S coded system is 6060 seconds.

5.2 Future Scope

This section presents the techniques and solutions which could be added to the MU Massive MIMO-OFDM system for the enhancement in their performance and easy implementation in practical situations. These suggestions for modifications in the system are necessary, so that they can satisfy the demand of required throughput and energy efficiency for the near future generation. The following points represents the field areas which are required to be searched upon for improved system performance.

- There is need to work on designing the precoding techniques for the system carrying more than one antenna at user terminal site.
- Development of more efficient hybrid algorithms is required for precoding process, which can work equally well for the instance of partial CSI knowledge at the base station.
- In case of practical implementation of the system, there is still need to develop appropriate techniques which can overcome the problem of pilot contamination for the instance of multicell scenarios.
- The research should be made in finding the solution to apply this hyper MIMO system for the case of FDD mode, as this field of research can provide many new assets to satisfies the growing demands of wireless communication systems and can contribute in fast data communication.

REFERENCES

- [1]. Tran L.C. *et al.* *Complex Orthogonal Space-Time Processing in Wireless Communications*. USA: Springer Science & Business Media, 2007.
- [2]. Goldsmith Andrea. *Wireless Communications*. U.K: Cambridge University Press, 2005.
- [3]. Oestges Claude and Clerckx Bruno. *MIMO Wireless Communications: from Real-World Propagation to Space-Time Code Design*. US: Academic Press, 2010.
- [4]. Alamouti S. M. (1998). A Simple Transmit Diversity Technique for Wireless Communications, *IEEE Journal on Selected Areas in Communications*, 16(8), 1451-1458.
- [5]. Paulraj A. J. *et al.* (2004). An Overview of MIMO Communications- a Key to Gigabit Wireless, *Proceedings of the IEEE*, 92(2), 198-218.
- [6]. Xu R. and Lau F.C.M. (2006). Performance Analysis for MIMO Systems Using Zero Forcing Detector Over Fading Channels, *IEE Proceedings-Communication*, 153(1), 74-80.
- [7]. Wang C. *et al.* (2007). On the Performance of MIMO Zero-Forcing Receiver in the Presence of Channel Estimation Error, *IEEE Transactions on Wireless Communications*, 6(3), 805-809.
- [8]. Baccarelli E., Biagi M. and Pelizzoni C. (2005). On the Information Throughput and Optimized Power Allocation for MIMO Wireless Systems with Imperfect Channel Estimation. *IEEE Transactions on Signal Processing*, 53(7), 2335-2347.
- [9]. Chuah C.N. *et al.* (2002). Capacity Scaling in MIMO Wireless Systems Under Correlated Fading, *IEEE Transactions on Information Theory*, 48(3), 637-650.
- [10]. Hwang T. *et al.* (2009). OFDM and Its Wireless Applications: A Survey, *IEEE Transactions on Vehicular Technology*, 58(4), 1673-1694.
- [11]. Prasad Ramjee. *OFDM for Wireless Communications Systems*. USA: Artech House, 2004
- [12]. Kapp S. (2002). 802.11a More Bandwidth Without the Wires, *IEEE Internet Computing*, 6(4),75-79.
- [13]. Litwin L. (2000). An Introduction to Multicarrier Modulation, *IEEE Potentials*, 19 (2), 36-38.
- [14]. Moose P. H. (1994). A Technique for Orthogonal Frequency Division Multiplexing Frequency Offset Correction, *IEEE Transactions on Communications*, 42(10), 2908-2914.
- [15]. Pollet T., Van Bladel M. and Moeneclaey M. (1995). BER Sensitivity of OFDM Systems to Carrier Frequency Offset and Wiener Phase Noise, *IEEE Transactions on Communications*, 43(234), 191-193.
- [16]. Schmidl T. M. and Cox D. C. (1997). Robust Frequency and Timing Synchronization for OFDM, *IEEE Transactions on Communications*, 45(12), 1613-1621.
- [17]. Jang J., and Lee K. B. (2003). Transmit Power Adaption for Multiuser OFDM Systems, *IEEE Journal on Selected Areas in Communications*, 21(2), 171-178.
- [18]. Cimini L. J. and Sollenberger N. R. (2000). Peak-to-Average Power Ratio Reduction of an OFDM Signal Using Partial Transmit Sequences, *IEEE Communications Letters*, 4(3), 86-88.
- [19]. Han S. H. and Lee J. H. (2005). An Overview of Peak-to-Average Power Ratio Techniques for Multicarrier Transmission, *IEEE Wireless Communications*, 12(2), 56-65.
- [20]. Jiang T., Yang Y. and Song Y.H. (2005). Exponential Companding Technique for PAPR Reduction in OFDM Systems, *IEEE Transactions on Broadcasting*, 51(2), 244-248.

- [21]. Spencer Q. H. *et al.* (2004). An Introduction to the Multi-User MIMO Downlink, *IEEE Communications Magazine*, 42(10), 60-67.
- [22]. Gesbert D. *et al.* (2007). From Single User to Multiuser Communications: Shifting the MIMO Paradigm, *IEEE Signal Processing Magazine*, 24(5), 36-46.
- [23]. Goldsmith A. *et al.* (2003). Capacity Limits of MIMO Channels, *IEEE Journal on Selected Areas in Communications*, 21(5), 684-702.
- [24]. Serbetli S. and Yener A. (2004). Transceiver Optimization for Multiuser MIMO Systems, *IEEE Transactions on Signal Processing*, 52(1), 214-226.
- [25]. Vishwanath S., Jindal N. and Goldsmith A. (2003). Duality, Achievable rates and Sum-Rate Capacity of Gaussian MIMO Broadcast Channels, *IEEE Transactions on Information Theory*, 49(10), 2658-2668.
- [26]. Choi L. U. and Murch R. D. (2004). A Transmit Pre-processing Technique for Multiuser MIMO Systems Using a Decomposition Approach, *IEEE Transactions on Wireless Communications*, 3(1), 20-24.
- [27]. Windpassinger C. *et al.* (2004). Precoding in Multiantenna and Multiuser Communications, *IEEE Transactions on Wireless Communications*, 3(4), 1305-1316.
- [28]. Sharif M. and Hassibi B. (2005). On the Capacity of MIMO Broadcast Channels with Partial Side Information, *IEEE Transactions on Information Theory*, 51(2), 506-522.
- [29]. Sadek M., Tarighat A. and Sayed A. H. (2007). A Leakage-Based Precoding Scheme for Downlink Multi-User MIMO Channels, *IEEE Transactions on Wireless Communications*, 6(5), 1711-1721.
- [30]. Li Q. *et al.* (2010). MIMO Techniques in WiMAX and LTE: A Feature Overview, *IEEE Communications Magazine*, 48(5), 86-92.
- [31]. Bolcskei H. (2006). MIMO-OFDM Wireless Systems: Basics, Perspectives and Challenges, *IEEE Wireless Communications*, 13(4), 31-37.
- [32]. Van Zelst A. and Schenk T. C. (2004). Implementation of a MIMO OFDM-Based Wireless LAN System, *IEEE Transactions on Signal Processing*, 52(2), 483-494.
- [33]. Stuber G. L. *et al.* (2004). Broadband MIMO-OFDM Wireless Communications, *Proceedings of the IEEE*, 92(2), 271-294.
- [34]. Barhumi I., Leus G. and Moonen M. (2003). Optimal Training Design for MIMO OFDM Systems in Mobile Wireless Channels, *IEEE Transactions on Signal Processing*, 51(6), 1615-1624.
- [35]. Xia P., Zhou S. and Giannakis G. B. (2004). Adaptive MIMO-OFDM Based on Partial Channel State Information, *IEEE Transactions on Signal Processing*, 52(1), 202-213.
- [36]. Wu Z. and Gao X. (2013). Improved MIMO-OFDM scheme for the next generation WLAN, *Journals of Systems Engineering and Electronics*, 24(1), 52-59.
- [37]. Jiang M. and Hanzo L. (2007). Multiuser MIMO-OFDM for Next-Generation Wireless Systems, *Proceedings of the IEEE*, 95(7), 1430-1469.
- [38]. Sadek M. and Aissa S. (2011). Leakage Based Precoding for Multi-User MIMO OFDM Systems, *IEEE Transactions on Wireless Communications*, 10(8), 2428-2433.
- [39]. Aggarwal P. and Bohara V. A. (2017). A Nonlinear Downlink Multiuser MIMO-OFDM Systems, *IEEE Wireless Communications Letters*, 6(3), 414-417.

- [40]. Marzetta T. L. (2015). Massive MIMO: An Introduction, *Bell Labs Technical Journal*, 20, 11-22.
- [41]. Larsson E. G. *et al.* (2014). Massive MIMO for Next Generation Wireless Systems, *IEEE Communications Magazine*, 52(2), 186-195.
- [42]. Lu L. *et al.* (2014). An Overview of Massive MIMO: Benefits and Challenges, *IEEE Journal on Selected Areas in Signal Processing*, 8(5), 742-758.
- [43]. Bjornson E. *et al.* (2014). Massive MIMO Systems with Non-Ideal Hardware: Energy Efficiency, Estimation, and Capacity Limits, *IEEE Transactions on Information Theory*, 60(11), 7112-7139.
- [44]. Bjornson E., Larsson E. G. and Marzetta T. L. (2016). Massive MIMO: Ten Myths and One Critical Question, *IEEE Communications Magazines*, 54(2), 114-123.
- [45]. Bjornson E., Larsson E. G. and Debbah M. (2016). Massive MIMO for Maximum Spectral Efficiency: How Many Users and Pilots should be Allocated?, *IEEE Transaction on Wireless Communications*, 15(2), 1293-1308.
- [46]. You L. *et al.* (2016). Channel Acquisition for Massive MIMO-OFDM with Adjustable Phase Shift Pilots, *IEEE Transactions on Signal Processing*, 64(6), 1461-1476.
- [47]. Studer C. and Larsson E. G. (2013). PAR- Aware Large-Scale Multi-User MIMO-OFDM Downlink, *IEEE Journal on Selected Areas in Communication*, 31(2), 303-313.
- [48]. Bjornson E., Bengtsson M. and Ottersten B. (2014). Optimal Multiuser Transmit Beamforming: A Difficult Problem with a Simple Solution Structure, *IEEE Signal Processing Magazine*, 31(4), 142-148.
- [49]. Fatema N. *et al* (2017). Massive MIMO Linear Precoding: A Survey, *IEEE Systems Journal*, (99), 1-12.
- [50]. Zhu D., Li B. and Liang P. (2016). A Novel Hybrid Beamforming Algorithm with Unified Analog Beamforming by Subspace Construction Based on Partial CSI for Massive MIMO-OFDM Systems, *IEEE Transaction on Communications*, 65(2), 594-607.
- [51]. Liang L., Xu W. and Dong X. (2014). Low-Complexity Hybrid Precoding in Massive Multiuser MIMO Systems, *IEEE Wireless communications Letters*, 3(6), 653-656.
- [52]. Sohrabi F. and Yu W. (2016). Hybrid Digital and Analog Beamforming Design for Large-Scale Antenna Arrays, *IEEE Journal of Selected Topics in Signal Processing*, 10(3), 501-513.
- [53]. Li J. *et al.* (2017). Robust and Low Complexity Hybrid Beamforming for Uplink Multiuser Mm Wave MIMO Systems, *IEEE Communications Letters*, 20(6), 1140-1143.
- [54]. Al-Askery A. J. *et al.* (2017). Performance Analysis of Coded Massive MIMO-OFDM Systems Using Effective Matrix Inversion, *IEEE Transactions on Communications*, 65(12), 5244-5256.
- [55]. Freeman J. C. Introduction to Forward-Error-Correcting Coding, Cleveland. Nasa Reference Publication, 1367, 1996.
- [56]. Wicker Stephen B. *Error Control Systems for Digital Communication and Storage*. Englewood Cliffs: Prentice-Hall, 1995.
- [57]. Ngo H. Q., *Massive MIMO: Fundamentals and System Designs*, Linkoping University Electronic Press, Sweden, 2015.

LIST OF PUBLICATIONS

- [1]. Kaur Harleen and Kansal Dr. Ankush (2018). Performance Evaluation of Coded Massive MIMO-OFDM System Using Phased Zero Beamforming for Broadcast Channel, *Springer Wireless Networks* (Communicated)
- [2]. Kaur Harleen and Kansal Dr. Ankush (2018). Evolution of MIMO-OFDM Systems to Full Dimension Multiuser MIMO-OFDM Systems, *International Journal of Communication Networks and Information Security* (Communicated)