

EARLY WARNING LANDSLIDE MONITROING SYSTEM

*Thesis submitted in partial fulfillment of the requirements for the
award of degree of*

**Master of Engineering
in
Electronics Instrumentation and Control**

Submitted By
**Archana Dubey
(Roll No. 801751001)**

Under the supervision of:
Dr. M. D. Singh
Associate professor
Thapar Institute of Engineering and Technology
&
Mr. Pratik Chaturvedi
Scientist - D
DTRL, Defence Research and Development Organisation



**ELECTRICAL AND INSTRUMENTATION ENGINEERING
DEPARTMENT
THAPAR INSTITUTE OF ENGINEERING AND
TECHNOLOGY
PATIALA – 147004
June 2019**

DECLARATION

I hereby certify that the work which is presented in this dissertation entitled, "Early warning landslide monitoring system" in complete fulfilment of the requirements for the award of the degree of Master of Engineering in Electronic Instrumentation and Control Engineering, submitted to Electrical & Instrumentation Engineering Department of TIET, Patiala is as authentic record of my own work carried under the supervision of Dr. M. D. Singh and Mr. Pratik Chaturvedi. It refers others researcher's work which is duly listed in the reference section. The matter contained in this dissertation has not been submitted, neither in part nor in full to any other degree to any other university or institute except as reported in the text and references.

Place: TIET, Patiala
Date: 28/06/2019

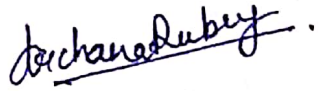

(Archana Dubey)
Roll No.: 801751001

It is certified that the above statement made by the student is correct to the best of my knowledge and belief.

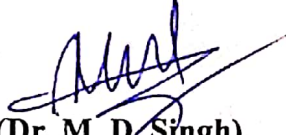
Date: 28/06/2019

(Dr. M. D. Singh)
Associate Professor
Electrical & Instrumentation Engineering Department
Thapar Institute of Engineering & Technology, Patiala

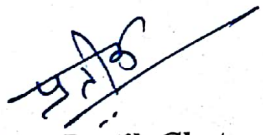
Date: 01.07.2019

(Mr. Pratik Chaturvedi)
Scientist - D
Defence Terrain and Research Laboratory
Defence Research and Development Organisation, Delhi

ACKNOWLEDGEMENT

I would first like to express my gratitude and honor to **Dr. M. D. Singh**, Associate professor, Electrical and Instrumentation Engineering Department, Thapar Institute of Engineering and Technology, Patiala and **Mr. Pratik Chaturvedi**, Scientist – D, Defence Terrain and Research Laboratory, Defence Research and Development Organisation, Delhi for their supervision and providing all the support needed for the completion of my research work of Master of Engineering.

I would like to acknowledge **Mr. Puneet Arya**, PHD student, Electrical and Instrumentation Engineering Department, Thapar Institute of Engineering and Technology, Patiala for his continues support, guidance and motivation for completing this project.

I am very grateful of all the lab members of Freescale lab and Instrumentation System Design lab for their cooperation during the entire thesis work.

I am very much thankful of **Capt. J. S. Malhi**, Care taker, PG Hostel, Thapar Institute of Engineering and Technology, Patiala for his help and support in performing different experiments in hostel required during entire thesis work.

Finally, I would like to thank my parents, elder sister Vandana Dubey and friends: Divya Dixit, Kanika, Sakshi Bhonsle, Manpreet Kaur, Tarun Arora, Abhishek Shingh, Dr. Venu Jaura and Dr. Devika Ghatak for their generous support, inspiration and encouragement.

ARCHANA DUBEY

ABSTRACT

Landslide is a serious natural calamity causing hundreds of deaths and damage of properties every year. There are several causes that triggers the landslide in which earthquake and volcanic eruption are the main nature driven causes. Moreover, there are some human activities that cause the destructions, such as, major constructions on hilly area, deforestation and uses of heavy machineries. In India, most of the landslide occurs in monsoon season. The increment in moisture content of the soil increases the driving force of the slope and makes it more prone to slide. In such a case, there is a need of a system that can continuously monitor the landslide prone zone and in case of any emergency, pre-alert the residential people of that area. There are several techniques already existed for this purpose such as DEM based calculation on aerial photography, LIDAR and remote sensing-based technique etc. Most of these techniques are expensive for implementation for a large area and a bit difficult task for early landslide prediction. Therefore, in such condition there exist a need of designing such system which should be least in cost and can alert the people of that area before any unfortunate event. In the present work, a Raspberry Pi 3, Model B+ along with USB webcam-based system has been designed for the continues monitoring of the system based on digital image processing. A soil moisture sensing assembly along with Arduino UNO and YL-69 hygrometer has been fixed on the slope that has been used as the triggering signal for the monitoring system. The prediction of landslide has been done based on the shifting in the position of markers that have been fixed on the slope. The entire technique has been based on MATLAB and Simulink. The detected landslide has been further conveyed to ThingSpeak website and from there to a MATLAB based android application to alert the residential people of that area. In the present work, the experiment has been done on a lab prototype. The concept can be further implemented on an actual landslide slope to check the actual feasibility of the design.

TABLE OF CONTENTS

CH. NO.	TOPIC	PAGE NO.
	DECLARATION.....	i
	ACKNOWLEDGEMENT.....	ii
	ABSTRACT.....	iii
	LIST OF FIGURES.....	vi
	LIST OF TABLES.....	vii
	LIST OF ACRONYMS.....	ix
1.	INTRODUCTION	1
	1.1 Introduction to landslide	1
	1.2 Mechanism behind landslide	1
	1.3 Causes of landslides	2
	1.3.1 Nature driven causes of landslide	2
	1.3.2 Human activities that causes landslide	3
	1.4 Types of landslide	3
	1.5 Brief history of landslides in India	6
	1.6 Objectives of thesis	8
	1.7 Organisation of work	8
2.	LITERATURE SURVEY	9
	2.1 Early researched and techniques in the field of EWS	9
3.	DESIGNING REQUIREMENT FOR EARLY WARNING LANDSLIDE MONITORING SYSTEM	12
	3.1 Introduction	12
	3.2 Hardware requirements	12
	3.2.1 Soil moisture sensor	13
	3.2.2 Arduino UNO	14
	3.2.3 Raspberry Pi	15
	3.2.4 Camera	16
	3.3 Software requirements	16
	3.4 Experimental prototype	16
4.	PROPOSED METHODOLOGY	18

4.1	Overview	18
4.2	Primary approach of work	18
4.3	Experimental aspects of proposed theory	24
4.3.1	Steps taken in landslide detection during imaging	26
4.4	Designing of real-time standalone monitoring system	27
4.4.1	Placement of markers on a landslide prone area	28
4.4.2	Simulink model for sensing soil moisture content	29
4.4.3	Raspberry Pi monitoring assembly	31
4.4.4	Detection landslide	32
4.4.5	Sending data on cloud	32
4.4.6	Development of android mobile application	33
5.	RESULTS AND DISSCUSSION	37
5.1	Results from primary approach of work	37
5.2	Results from recorded data of real-time experiment	37
5.3	Results from real-time standalone system	38
6.	CONCLUSION AND FUTURE SCOPE	41
6.1	Conclusion	41
6.2	Future scope	41
	REFERENCES	42

LIST OF FIGURES

Figure No.	Caption	Page No.
1.1	Mathematical representation of landslide	1
1.2	Physical changes in slope during landslide	2
1.3	Rotational landslide	4
1.4	Translational landslide	4
1.5	Lateral spreading type landslide	5
1.6	Debris flow landslide	5
1.7	Rock fall type landslide	6
1.8	Rock toppling landslide	6
3.1	YL-69 soil moisture sensor	12
3.2	Components of soil moisture sensor	12
3.3	Arduino UNO	13
3.4	Raspberry Pi 3, Model B+	14
3.5	GPIO pin diagram	14
3.6	C-140 USB webcam	15
3.7	Laboratory prototype of landslide	16
3.8	Position of markers	16
4.1	Flowchart of primary approach of landslide detection	18
4.2	Reference approach for landslide detection	19
4.3	Displacement on markers position with each passing frame	21
4.4	Detection of moving object with image processing	22
4.5	Mapping of 2-D image into real time system	23
4.6	First captured frame of the landslide prone area	24
4.7	Shifting in position of markers with each passing frame	26
4.8	Detection of shifts in markers position	27
4.9	Flowchart of designing an early warning system for landslide	28
4.10	Placement of markers on slope	29
4.11	Simulink model for measuring the moisture content in soil	29
4.12	LED indication off when moisture value lesser than threshold	30
4.13	Generating an alarming signal that triggering landslide	30
4.14	Block diagram of landslide monitoring assembly	31
4.15	Activation of field station monitoring assembly	31

4.16	Detection of different markers in reference image	32
4.17	Displacement of markers from their original position	32
4.18	Sending landslide data on cloud	33
4.19	Simulink support packages for interacting Raspberry Pi with android devices	33
4.20	Android software development kit	34
4.21	Driver installation of selected android device	34
4.22	Configuring test application on the android device	35
4.23	Generating test application	35
4.24	MATLAB based android application	36
4.25	Alerting notification on android application	36
5.1	Responses of soil moisture sensor with respect to time	39

LIST OF TABLES

Table No.	Caption	Page No.
3.1	Camera specification	15

LIST OF ACRONYMS

Symbol	Description
DEM	Digital Elevation Method
RS	Remote sensing
EO	Earth observations
LIDAR	Light Detection and Ranging
BOTDR	Brillouin Optical Time Domain Reflectometry
FBG	Fibre Bragg Grating
PSI	Persistent Scatterers Interferometry
IoT	Internet of Things
BRO	Border Road Organisation
ITBP	Indo Tibetan Border Police
EWS	Early Warning System
HIRESSS	High Resolution Slope Stability Simulator
IPI	In Place Inclinometers
AWS	Automatic Weather Station
UAV	Unmanned Aerial Vehicle
DTM	Digital Terrain Model
FOV	Field of View
MATLAB	Matrix Laboratory
T _x	Transmit
R _x	Receive
PWM	Pulse Width Modulation
AREF	Analog Reference
USB	Universal Serial Bus
GPIO	General Purpose Input Output
HDMI	High Definition Multimedia Interface
WIFI	Wireless Fidelity
BLE	Bluetooth Low Energy
GPU	Graphical Processing Unit
OSMC	Open Source Media Centre
OpenELEC	Open Embedded Linus Entertainment Centre

BSD	Berkeley Software Distribution
OS	Operating system
NOOBS	New Out Of the Box Software

1.1 Introduction to landslide:

A downward movement of a large quantity of landmass that can be found at the steep area of slopes at mountains which contains a huge amount of waste along with it is known as landslide. In geographical terminology, a landslide occurs when a slope of hill turns from stable state to unstable state because of earth’s gravity [1]. Depending upon the cause of factors, these geographical changes can be sudden or slow which end up with the massive destruction all around. A global dataset analysis related with landslides show that nearly 55997 people were killed in about 4862 landslides related events since January 2004 to December 2016 [2]. Most of these landslides were non seismic and triggered because of heavy rainfall. According to a report, India is listed on the top of the landslide related deaths with a statistic record of nearly 11,000 deaths in last 12 years [3]. In the Himalayan region only, it causes about 200 deaths with a huge loss of property and infrastructure nearly costing 82 million dollar per year [4].

1.2 Mechanism behind landslide:

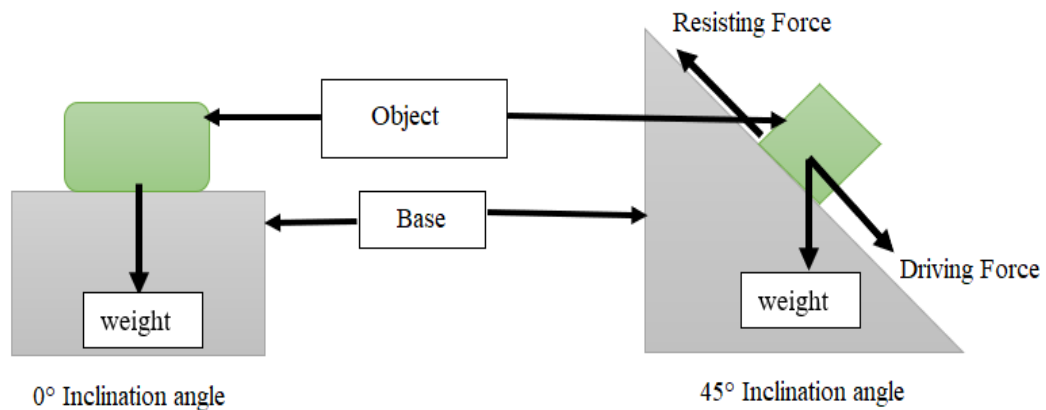

Figure 1.1: Mathematical representation of landslide

In mathematical terms, any object at a slope can be defined in terms of factor of safety (F). This safety factor can be defined in terms of resisting force and driving force. Which is,

$$F = \frac{R}{D} \dots\dots\dots (1.1)$$

Where, *R* is resisting force and *D* is driving force.

The role of resisting force is to resist the object situated on the steep side of the slope from the downward movement and prevent the sliding. It is inversely proportional to the angle of the slope of the mountain or hill and is directly proportional to the angle of friction of the particular material used to make the slope [5]. Whereas, a driving force is the force which makes the object more prone to slide under the influence of gravity. Therefore, driving force represents the force by which the mass takes the downward flow. In general, if the ratio of resisting force to the driving force is lesser than '1' than there occurs a landslide. While if the value of resisting force is equal to the value of driving force than there will be no landslide. The resisting force reduces during heavy rainfall and earthquake as well.

During a landslide there occurs three main events in a sequence. Initially, the slope of the particular landmass fails which correspondingly causes a large amount of debris flow containing mud, rock, vegetation and other waste. Finally, it gets deposited at the toe of hill.

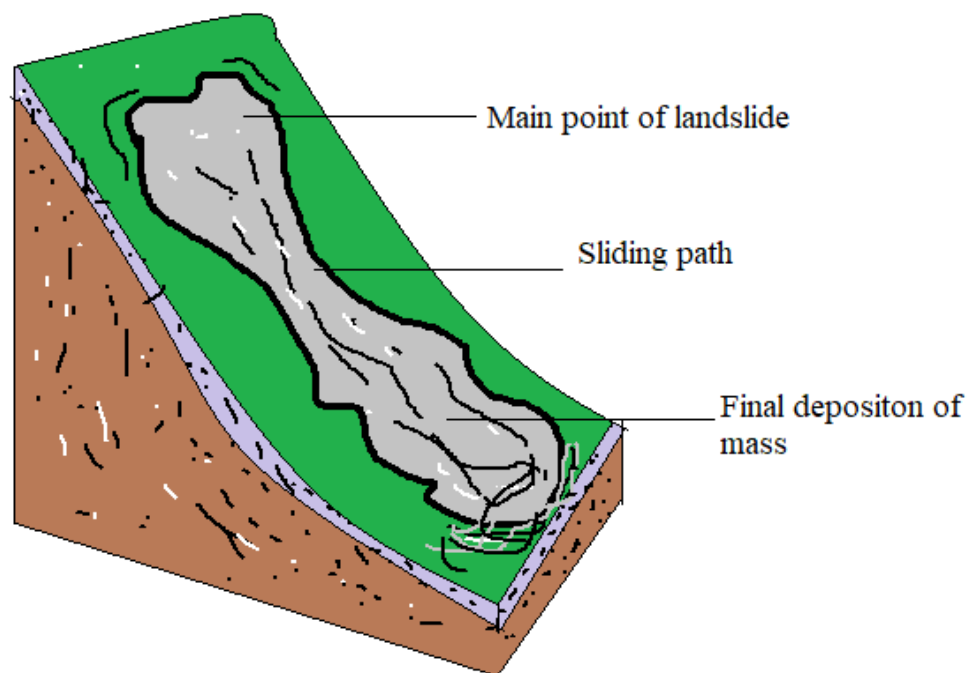

Figure 1.2: Physical changes in slope during landslide

1.3 Causes of landslides: -

Broadly, causes of landslides can be divided into two different categories. First is due to nature driven causes and other is due to different human activities which cause mass destructions and subsequently governs the landslides.

1.3.1 Nature driven causes of landslides: -

- Increment in the pore pressure or underground water pressure.
- Earthquake.
- Volcanic eruption.
- Snow and glaciers melting.
- Excessive rainfall.
- Erosion of the toe of the hill because of nearby flowing river or ocean.
- A wild fire which subsequently causes the massive destruction of the vegetation on the particular part of the hill.

1.3.2 Human activities that causes landslides: -

- Deformation, cultivation and construction.
- Removing deep-rooted vegetation.
- Heavy earthwork like mining.
- Blasting for removing certain part of the hill.
- Use of heavy machineries for the construction work that cause a large amount of vibrations creates seismic effects in the mountains.

1.4 Types of landslides: -

a) Rotational landslide: A type of landslide where the mass started moving downward along a certain surface of the slide. When this slipping surface took a shape, which looks curved face it is known as rotational landslides. In this, movement occurs in curved and concave geometry and it uproots a very huge amount of landmass. The main cause behind these kinds of landslides are overload of the sliding surface or increment in the steep angle which correspondingly decreases clay strength and ends with landslide [6].

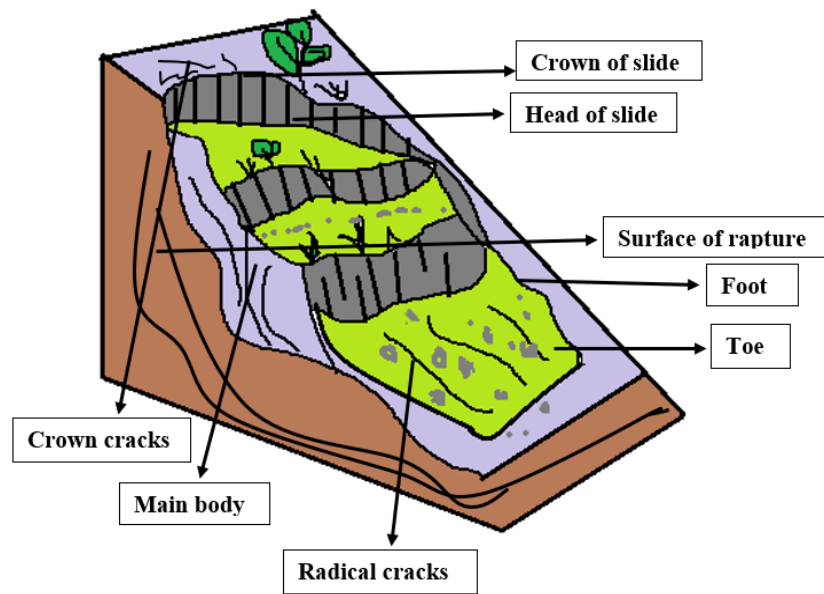

Figure 1.3: Rotational landslide

b) Translational landslide: In translational landslides, slides break from weak joints and cracks and moves downwards. In this type of sliding usually the surface of slope is straighten and breaks the bond with mud in a rail [7].

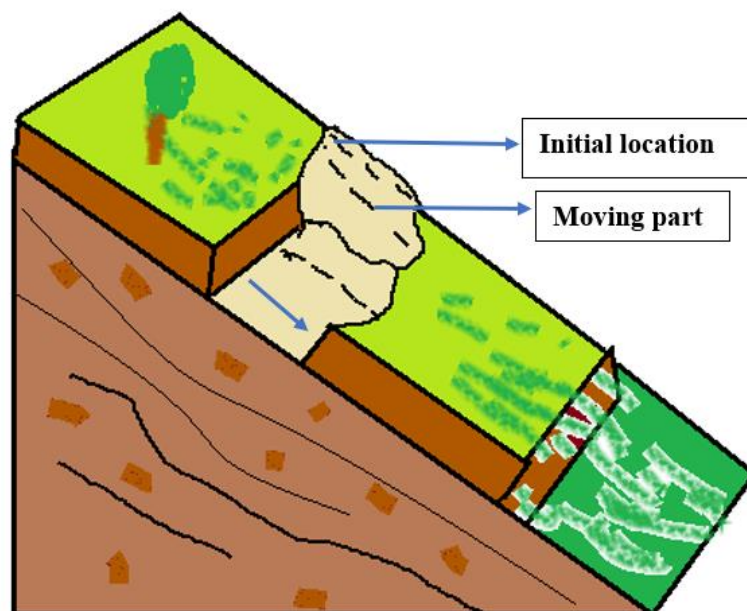

Figure 1.4: Translational landslide

c) Lateral spreading type landslide: In the lateral spreading type of landslides there and on soil constructions created because of earthquake or excessive liquification or water leakage from that area [8].

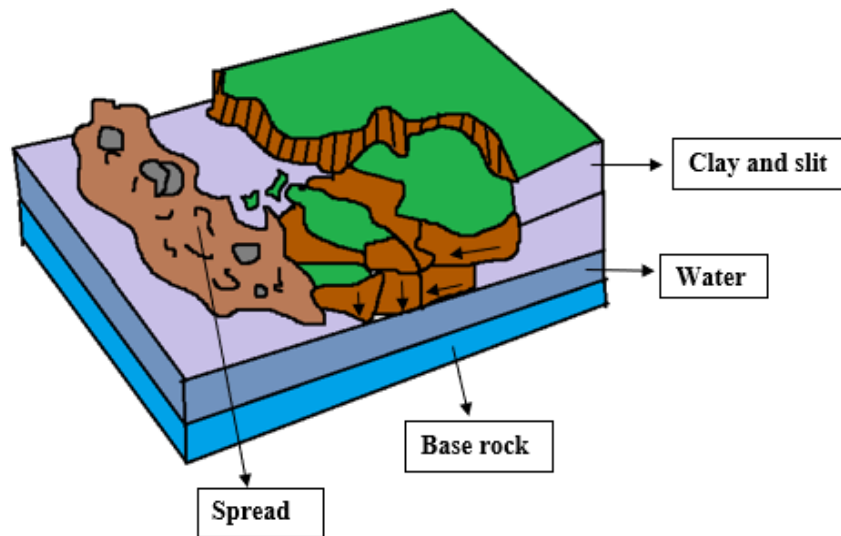

Figure 1.5: Lateral spreading type landslide

d) Debris flow: In the debris flow type of landslide, a large amount of soil, mud or rocks started moving down side of the hill. This kind of landslide can be often seen during monsoon season where due to heavy rainfall the resisting force of the safety factor of the slope decreases that accelerates the driving force. The gravity plays an important role in its working. In debris flow, the speed of landslides is very fast [9].



Figure 1.6: Debris flow landslide

e) Rock fall: When a big size rock found rolling down from the cliff of mountains or hills because of earthquake, heavy rainfall or simply because of the influence of gravity,

it is known as rock fall landslides. A large amount of rocks and stones get collected on the toe of hill which ultimately blocks the nearby roads [10].

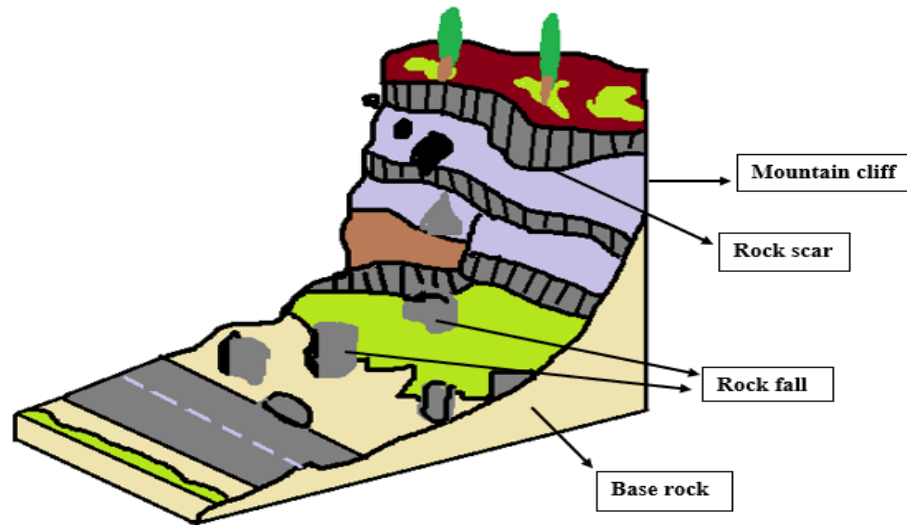

Figure 1.7: Rock fall type landslide

f) Rock toppling: These kinds of landslides occur when the rocks move around a certain point near their base, because of excessive vibrations or seismographic changes. Therefore, these types of landslide usually occur during earthquakes [11].

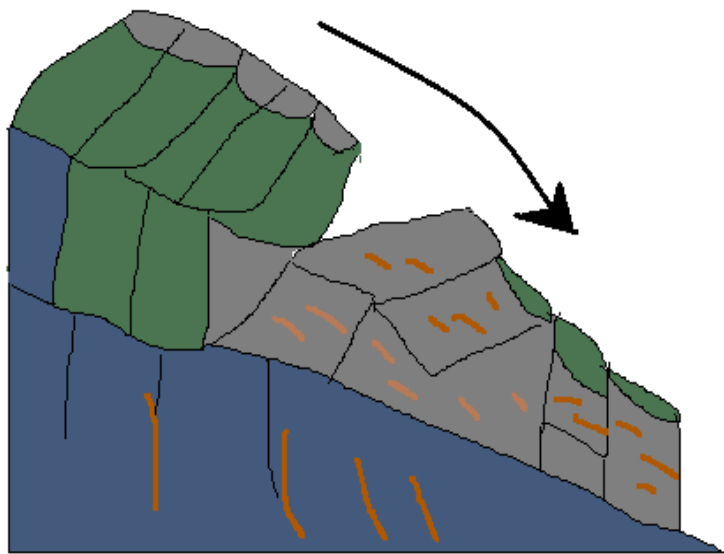

Figure 1.8: Rock toppling landslides

1.5 Brief History of landslides in India:

Guwahati landslide: This unfortunate event occurred on 18 September, 1948 because of heavy rainfall. It almost destroyed the entire village with a record of almost 500 deaths [12].

Malpa landslide: Malpa is village in Pithoragarh district of Uttarakhand. On 18 August 1998, this village faced its worst nightmare ever because of massive landslide with a record of 221 deaths, including 60 pilgrims travelling to Tibet for Kailash Mansarovar Yatra [13]. This landslide created debris flow and rock falls at a massive area in all its surroundings. There were multiple earthquakes in this region during 1979-80 which has marked this place as seismic zone. Even then the unplanned constructions and urbanization have been done that triggered the landslide and caused such a huge destruction.

Ukhimath landslide: Ukhimath is in Rudraprayag region in Uttarakhand. On 14 September 2012, this place faced a massive destruction of roads, agriculture land and other infrastructure because of trigger of approximately 505 landslides due to cloudburst which ultimately caused a heavy rainfall. This incident killed approximately 50 people, around 20 people reported as missing and also left 500 locals as homeless [14].

Kedarnath landslide: Kedarnath tragedy has been experienced in mid of June of 2013 because of sudden flood in Saraswati and Dudhganga river which eventually caused massive debris flow that affected more than 9 million people. Thousands of human-casualties around 4021 people missing report, destruction of 40200 villages, damage of 2513 houses and more than 1 lakh local residentials and approximately 70,000 tourists have been left without any hope to move anywhere [15].

Northern Sikkim landslide: On 24 September 2012, massive landslides have been triggered because of heavy rainfall in Gangtok of Sikkim. That has been ended with reportedly 27 casualties including ITBP and BRO officers and several people found missing [16].

Darjeeling landslide: On 2 July 2005, multiple landslides had brutally affected the Darjeeling district of West Bengal. It had killed over 38 people, 23 found missing and over 500 people displaced as an impact of this massive destruction [17]

Amboori landslide: On 9 November 2001, Thiruvananthapuram District of Kerala faced one of the worst tragedies of decade in Amboori that has taken nearly 38 lives because of more than required monsoon rainfall at Kurisumalai hill in 2 hours of time span [18].

Malin landslide: Malin is the remote place in Pune city in Western Ghat. This village has experienced a massive destruction because of landslides by nearby hillock on 30 July 2014 that has uprooted almost entire village of 50 families. Approximately 150 people had become the victim of incident and 100 reported as missing [19].

1.6 Objectives of thesis:

In the present research work, there are basically two research objectives. First one is the detection of landslide which has been achieved by placing some specific markers on the landslide active zone and based on the shifting in these markers position because of increment in moisture content of the soil, calculating the average velocity at which displacement in markers positions have been noticed. On the basis of these results, the second objective is to generate an alarming notification on an android based mobile application.

1.7 Organisation of work:

The present thesis work is organised as below:

- Chapter 1 introduces the basic mechanism of landslide and the different reasons that trigger that mechanism. It also gives a brief review about the types of landslides and past experiences faced due to landslides in India. This chapter also explains the objectives of the thesis work.
- Chapter 2 contains the literature survey of the past researches that have been done in the field of designing of landslide monitoring system. A brief summary of each technique along with their advantages and disadvantages has been discussed in this chapter.
- Chapter 3 describes the different designing requirements of the system. It contains the explanation about each hardware components along with their pin diagrams and other required specifications. It also contains the information about the experimental lab prototype designed for the present research purpose.
- Chapter 4 explains the methodology of work of the proposed concept. It also describes the different experiments that have been done for achieving the task along with their step wise step explanations.
- Chapter 5 describes results generated from different experiments done for the present thesis work.
- Chapter 6 concludes the thesis and explains about the future scope of the present research work.

CHAPTER 2

LITERATURE REVIEW

2.1 Early researches and techniques in the field of EWS:

Landslides causes massive destruction in all its surroundings. It not only damages the infrastructure but also kills thousands of people each year around the globe. In such circumstances, there was a need to develop such technique which can monitor those part of the landmass which are more prone to landslides. So, in case of any alarming situation, necessary precaution can be taken. Some of these techniques are discussed below:

Casson *et. al.* [20] describes a technique based on DEM calculation on stereoscopic aerial photographs for the analysis of landslides. Based on the image correlation, ortho-rectification of these aerial photographs has been done. In stereoscopic photography, two different photographs of same location are taken with slightly different angle of view. These photographs from different camera parameter gives height of each object and so if any shifts will occur then that can be detect.

M. Scaioni *et. al.* [21] describes RS-based technique to investigate landslides which includes EO using various non-contact techniques with the help of numerical models and geological sensors which could be helpful for the analysis of risk possessing slopes that can further be useful to reduce the risk of landslides. In this type of investigation different optical imageries of landmass involved in earlier landslides were taken in a single map and optical, microwave, thermal and laser scanning based data have been taken for the RS purpose.

McKean *et. al.* [22] describes high-resolution airborne altimetry-based or LIDAR based landslide detection technique. This technique is used to scan the terrain's surface and investigate the roughness of surface based on circular, one-dimensional or two-dimensional statistics in DEM. With the help contrast, texture and continuity in roughness the landmass prone to landslide can be distinguish. The landmass which is less active to landslide seems smooth while the more active slope's surface seems rough. A Laplacian factor can be used for the mapping purpose for this technique.

D. Huntley *et. al.* [23] introduced a technique for monitoring landslides based on Fibre Bragg grating and Brillouin optical time domain reflectometry method on an active landslide. In the time domain reflectometry method, time duration between laser light

emission and its reflected back received signal is calculated. Based on the timing analysis object's distance has been calculated. BOTDR and FBG played an important role to receive and transmit the desired signal to make the system a real-time monitoring system.

M. E. Reid *et. al.* [24] suggested a technique for the real-time monitoring of the active landslide slopes remotely with the help of different sensors signals and transmitting them via radio transmitters.

B. Silvia *et. al.* [25] introduced to technique for monitoring displacement cause of landslides with the help of PSI analysis. In this technique, TerraSAR-X data received from different satellites were compared with PSI data and with the help geological and geomorphic data available from historical experience a landslide related prediction has been done.

G. Rossi *et. al.* [26] proposed a methodology to monitor shallow landslides based on HIRESSS to analyze the stability of slope. This technique has been taken under consideration to monitor a large area of landslide risk with the help of parallel computational techniques. The entire system has been divided into two parts hydrological and geotechnical respectively. In which hydrological model collects rainfall data based on Richard equation analysis and geotechnical model calculate FS based on the method of infinite slope method that considers the condition of unsaturated soil. The results from both these models then provided to a simulation model of Monte Carlo which subsequently predicted the slope failure in terms of probability.

P. Mercogliano *et. al.* [27] expressed a significant work in field of EWS for landslide. This system was based on rainfall statistical data. It was a practical approach of the method proposed by G. Rossi *et. al* [26]. which also included a forecasting technique with 48 hours of time of lead and in a range of 3200 km² for a shallow landslide.

T. Carla *et. al.* [28] proposed a technique for designing an EWS before collapsing the slope based on the inverse velocity method that derived from moving average and exponential soothing algorithm.

S. C. Stiros *et. al.* [29] explained a theory based on geodetical records for deriving a landslide monitoring system. He designed a landslide monitoring system based on the changes noticed in the radical distance of the control point on the slope which correspondingly able the define its velocity of movement in the slope of landslide.

S. K. Mittal *et. al.* [30] introduced a technique for designing landslide monitoring instrumentation. This system included with Pentium based processor card for the data

acquisition which acquire data from 80 sensors situated on a slope prone to landslide along with optical modems for the communication links with control station.

D. P. Kanungo [31] suggested a real time monitoring system for the prediction of landslide based on the technique of wireless instrumentation. For the data acquisition purpose different sensors such as IPI, AWS, piezometer and extensometer have been used in this technique. Based on the data acquired from different sensors a correlation has been developed between them to generate a threshold signal for the warning purpose.

U. Niethammer *et. al.* [32] proposed a UAV based landslide monitoring system which has been integrated with digital cameras that was proposedly replaced the remote sensing-based monitoring system with its high resolution and flexible investigation method. Further analysis has been done based on the images captured from aerial photography used for DTM and ortho- mosaic generation for the monitoring purpose of landslide.

P. K. Mishra *et. al.* [33] suggested a method of landslide monitoring which has been derived by technique of computer vision. This methodology was based on the concept of tracking the location of moving object using an algorithm of background subtraction and entropy thresholding which subsequently used for the estimation of moving velocity of the object that further used in alarm generation purpose in case of noticed risk.

P. Chaturvedi *et. al.* [34] proposed a methodology to design an early prediction system for the landslides and with the help of IoT framework, alerting the residential people of that area. This MEMS sensor-based technique was proposed to derive low cost solution for the landslide monitoring purpose.

CHAPTER 3

DESIGNING REQUIREMENTS FOR EARLY WARNING LANDSLIDE MONITORING SYSTEM

3.1 Introduction:

In the present research work, YL-69 soil moisture sensor along with the Arduino Uno has been taken for testing the moisture content of the soil during rainy season that has been further useful for setting a threshold to activate the landslide monitoring unit. Raspberry pi 3, Model B+ along with the USB camera has been used for development of landslide monitoring design. MATLAB programming language has been used for the programming purpose of the entire system to make it a completely standalone device. Further an android mobile application has been created for alerting about the landslide risk to the residential people of the zone according to the data collected from the cloud.

3.2 Hardware requirements:

3.2.1 Soil moisture sensor:

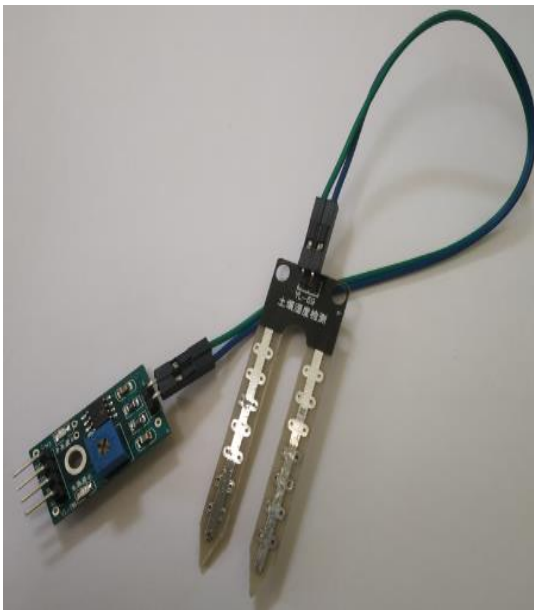

Figure 3.1: YL-69 Soil moisture sensor

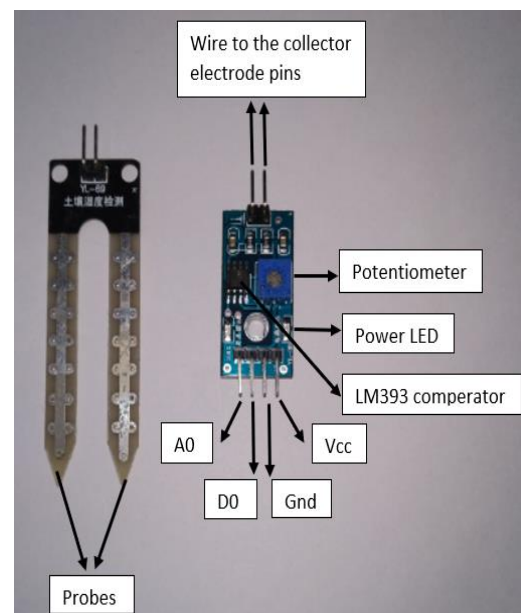

Figure 3.2: Components of soil moisture sensor

Soil moisture sensor commonly known as hygrometer has been used for the purpose of calculating the moisture content in the soil during rainfall. Operating range of YL-69 soil moisture sensor varies from 3.3-5V at 35 mA input current that corresponds to an output voltage range of 0-4.2V [35]. The device also contains onboard potentiometer for the sensitivity adjustment purpose of Digital outputs. The onboard comparator

LM393 can be used for the comparison of the output with a set threshold value. This can be taken in use when acquiring outputs from digital Pin. Output of the device varies from 0-1023 in ADC range that indicates its Analog output value. Pin A0 can be used for Analog output purpose and Pin D0 for the digital output purpose while pin Vcc and Gnd can be used for the purpose of supply voltage and ground voltage respectively. The calculated output value has been further used for calculating the moisture percentage of the soil. When the soil was completely dry, its ADC value found to be 1023 or in a 0% moisture range. While increment in moisture content of the soil decreases its analog value. The percentage of moisture can be calculated as [36]:

$$\text{Analog Output} = \frac{\text{ADC value}}{1023} \dots\dots\dots(3.1)$$

$$\text{Moisture Percentage} = 100 - (\text{Analog Output} * 100) \dots\dots\dots(3.2)$$

3.2.2. Arduino UNO:

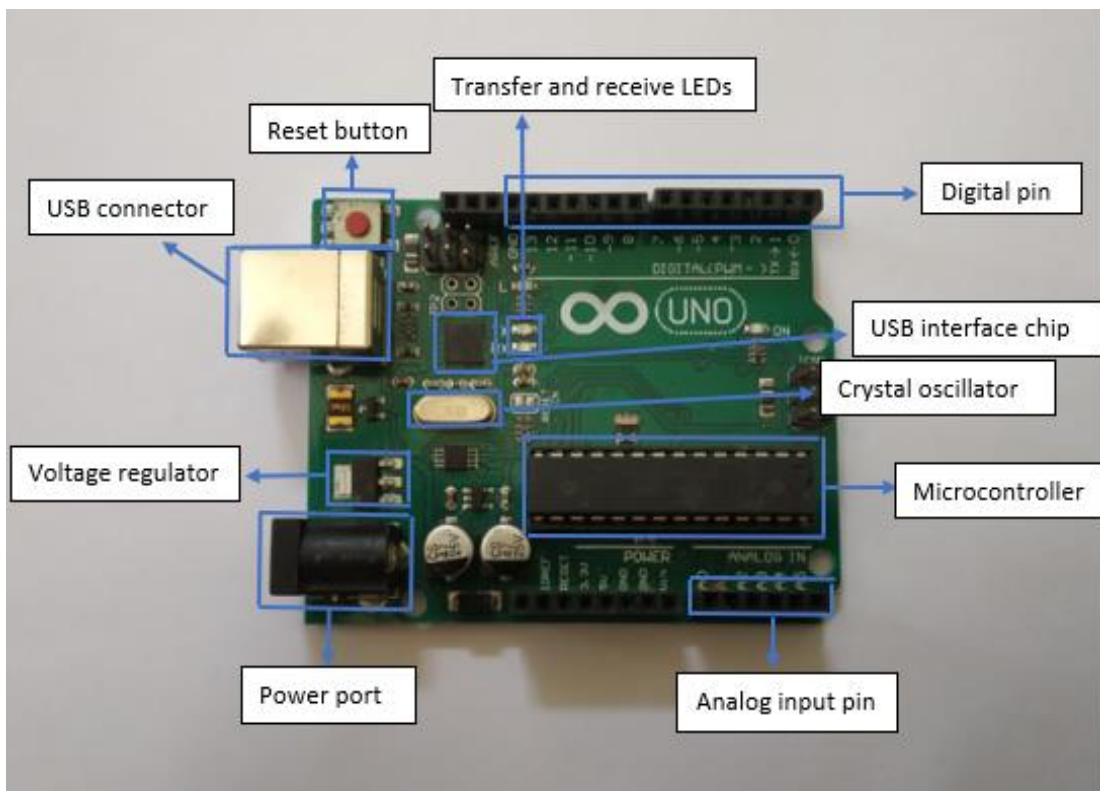

Figure 3.3: Arduino UNO

Arduino UNO is a microcontroller based on ATmega328P that contains 14 Digital pins which work on the logical input (0 or 1) and 6 analog pins from A0 to A5 on its board. Voltage acceptance range of Arduino varies from 7- 20 Volts. Power can be supplied by 9V external battery or by type-2 USB cable. [37]. Crystal oscillator helps to deal with the time in Arduino board. In Arduino UNO crystal oscillator works on the

frequency 16 MHz. The reset button can be useful in the case when there is a need to restart the program from the very beginning. Analog pins can read analog values from any analog sensors and then they convert these values into a digital signal so that microcontroller can process on that data. The microcontroller can be programmed into Arduino IDE. While for this research work, programming was performed on MATLAB and Simulink model of MATLAB. Tx and Rx LEDs are used for representing serial communication. Tx LED glows when the data is transferred and when Arduino receives data then Rx LED flashes. The intensity of glow of LEDs depends on the baud rate at which the Arduino is performing its processing. Six of the fourteen digital pins of the board generate PWM output. AREF pin can be used to set a reference voltage for analog pins to set its upper limit of working. Voltage regulator controls the input voltage of the board and maintains this voltage in the further working ranging from 0-5 Volts [38].

3.2.3 Raspberry Pi:

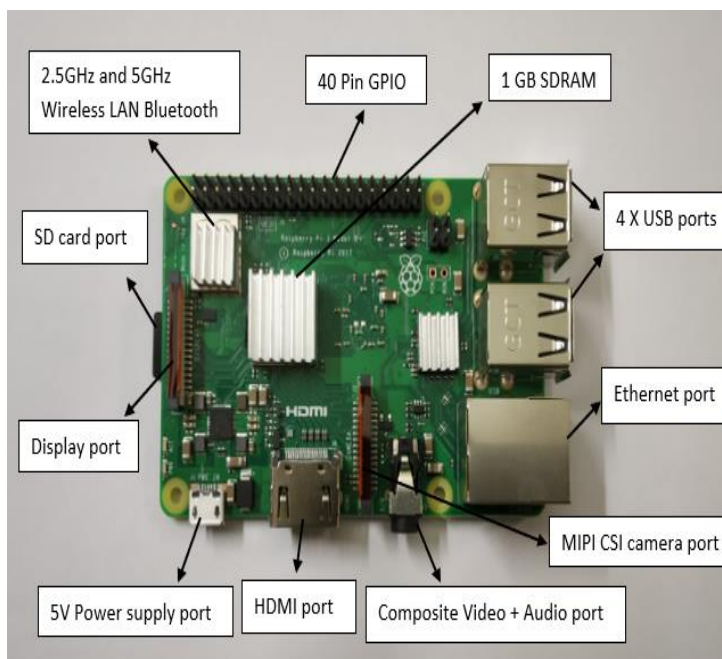

Figure 3.4: Raspberry Pi 3, Model B+

3.3V	1	2	5V
GPIO2	3	4	5V
GPIO3	5	6	GND
GPIO4	7	8	GPIO14
GND	9	10	GPIO15
GPIO17	11	12	GPIO18
GPIO27	13	14	GND
GPIO22	15	16	GPIO23
3.3V	17	18	GPIO24
GPIO10	19	20	GND
GPIO9	21	22	GPIO25
GPIO11	23	24	GPIO8
GND	25	26	GPIO7
DNC	27	28	DNC
GPIO5	29	30	GND
GPIO6	31	32	GPIO12
GPIO13	33	34	GND
GPIO19	35	36	GPIO16
GPIO26	37	38	GPIO20
GND	39	40	GPIO21

Figure 3.5: GPIO pin diagram [39]

Raspberry Pi 3 Model B+ is low-cost, credit card size computer, based on Linux operating system that has been introduced by Raspberry Pi foundation. This computer board contains 4 USB ports for interacting with peripherals, 40 pin GPIO, HDMI port, camera port, ethernet port, onboard WiFi and Bluetooth along with composite video and audio port. The combination of CPU and GPU on a single chip makes the processing of Raspberry Pi 3 B+ faster than its earlier versions. 802.11ac (5th generation) WiFi technology that runs at both 2.4GHz and 5GHz bands is available on the board shown in Figure 3.4

along with BLE 4.2 Bluetooth. The ethernet port works on the speed of 300 Mbit/s. Raspberry Pi works on the 1.4 GHz clock speed and its RAM size is 1GB. The board is based on the ARM Cortex-A53 and it also contains a 4-pole stereo output composite audio and video port of size 3.5 mm. It also has two LEDs PWR and ACT. PWR LED glows red when board is connected with 5V power supply and green light of ACT LED shows that any activity is going on the board. If the ACT LED does not glow then it represents a defective pi board [39]. The available SD card port used for the loading of operating system on the board and also for the purpose of storing data. The operating temperature for the proper working of Pi 3 board is 0-50°C [40]. Raspberry Pi can work on various operating system such as Raspbian Stretch, Raspbian Jessie, OSMC, OpenELEC, RISC OS, Windows IoT Core, Lakka, RaspBSD, RetroPie, Ubuntu Core and Linutop. NOOBS include all the various OS and it provides a facility to choose one of these OS during the time of installation [41].

3.2.4 Camera:



Figure 3.6: C140 USB web camera

Table 3.1: Camera specifications [42]

FOV	60°
Focal length	4 mm
Optical resolution	1280 x 960, 1.2 MP
Image capture	320 x 240, 640 x 480, 800 x 600
Maximum framerate	30 fps
System requirement	Minimum 1GHz CPU speed, Minimum 1GB RAM
OS support	Windows XP, 7,8,10 or later Mac 10.10
Connection type	USB 2.0

3.3 Software requirements:

In this research work, MATLAB programming language has been used for designing of a landslide monitoring system as a standalone device. Following MATLAB libraries have been used for the purpose of interfacing and interacting with different devices used, IoT and finally for creating an android mobile application:

- Simulink support package for Arduino hardware
- MATLAB support package for Raspberry Pi hardware
- Simulink support package for Raspberry Pi hardware
- MATLAB support package for USB webcams
- Simulink support package for Android device
- MATLAB support for MinGW-w64 C/C++ compiler

3.4 Experimental prototype:



Figure 3.7: Laboratory prototype of landslide



Figure 3.8: Position of markers

Figure 3.7 shows an experimental prototype for the purpose of present research work. From the researches, it has been found that most of the landslides in India occur in monsoon season. The increase in moisture content of the soil of mountain's slope triggers the landslides. The dimensions of above prototype were 1.5ft X1.5 ft. The height of the slope was 1 ft. Initially, three flag shape markers of 4 inches height deep rooted 2 inches inside the soil were taken for the experimental purpose. The soil taken for

making the soil was from Patiala, Punjab region. The soil of this region generally grows in semi-arid condition with pH scale value 7.8-8.5. The soil type of this area found of alluvial type. The average rainfall in the monsoon season of this area found to be 754 mm on an average [43]. This soil found rich in potash and phosphorus and deficient in nitrogen. Such conditions make this soil perfect for the vegetation growth [44][45]. This type of soil composition found in Doon Valley region and in Shivalik mountains more specifically in Mussoorie region [46].

4.1 Overview:

In this chapter, the technology used for the designing of an early warning landslide monitoring system has been explained. In the present research work, a Raspberry Pi based standalone system has been designed for the real time analysis purpose of a landslide prone area. The idea of monitoring of landslide prone zone was based on the images captured from camera attached to the Raspberry Pi board. The decision taken from the designed algorithm for Raspberry Pi assembly has been transferred to the cloud and then further the data has been published on an android application [45]. The entire Raspberry Pi assembly has been affixed on a pole situated in front of the hill at some distance.

4.2 Primary approach of work:

Figure 4.1: Flowchart of primary approach of landslide detection

In the primary approach of design and development of early warning landslide monitoring system, the algorithm described in Figure 4.1 has been performed on an offline video of a landslide [46]. In this experiment, the first frame of the video has been taken as the reference image or a background image and the next captured images have been considered as its foreground image.

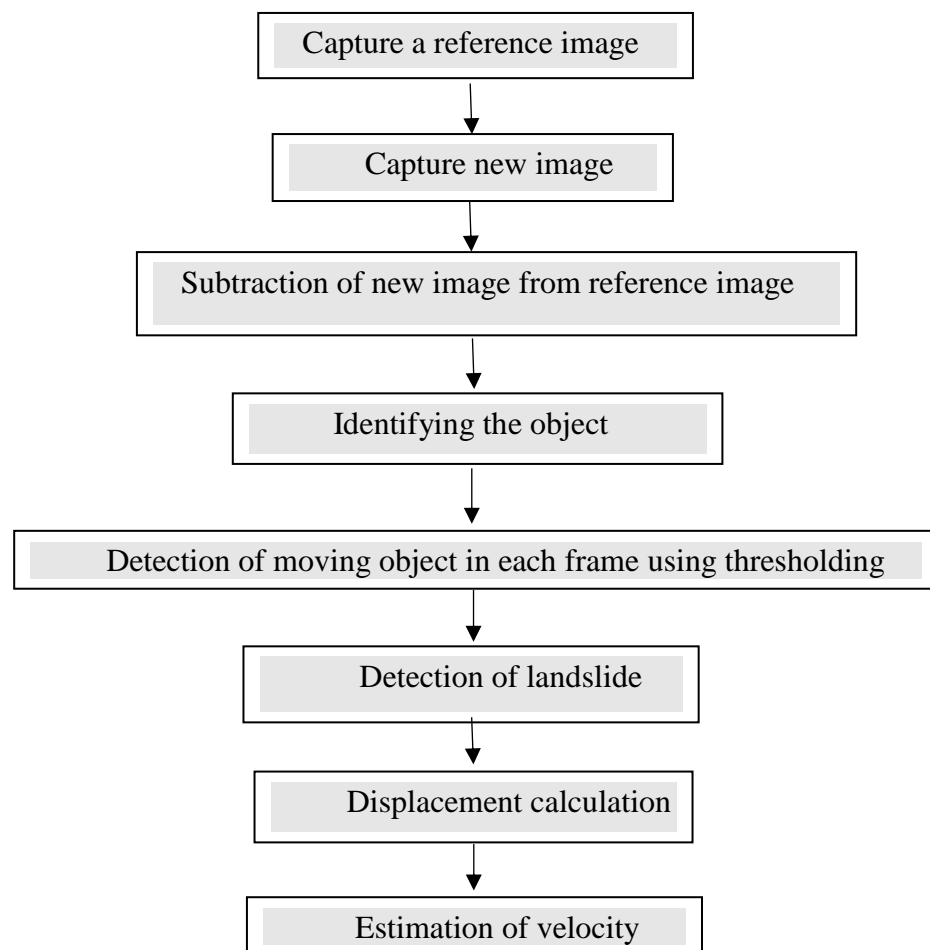

Figure 4.2: Reference image for landslide detection

A red colour marker has been fixed on the landslide slope and the first picture taken from the camera considered as reference image. When the slope failure occurred, the marker has been started displacing from its initial position. The displacement in the marker has been noticed in the next captured frames.



(a)



(b)



(c)



(d)



(e)

Figure 4.3: Displacement in markers position with each passing frames (a), (b), (c), (d), (e)

The pixel intensity of the marker has been known with the help of digital image processing on the MATLAB programming software and so, this intensity value has been considered as a threshold value. The pixel intensities other than the pixel value of marker have been made '1' or white so that the marker can be extracted out as a single moving object easily.

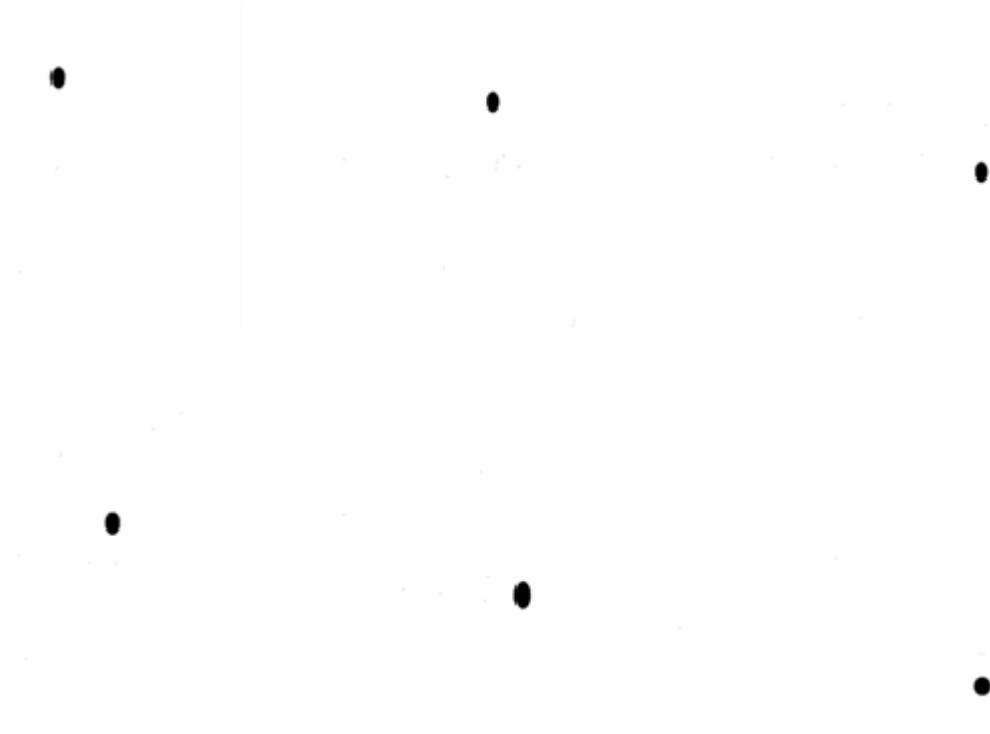

Figure 4.4: Detection of moving object by image processing

The shift in the marker position has been noticed with each passing frame by the image processing tool of MATLAB. The calculation to measure the shift in the marker position has been done by locating its centroid values in each frame. The indices of centroids have been recorded till the marker disappear from the frame. The total displacement in the marker position has been calculated by distance formula. Such as,

$$d = \sqrt{(y_2 - y_1)^2 + (x_2 - x_1)^2} \dots\dots\dots (4.1)$$

Where, x_1, x_2, y_1, y_2 are x and y coordinates of first and last frames. This technique was able to find the displacement only in two-dimensional frame. Therefore, to calculate the original movement in the real-time scenario camera specification must be known. In this primary approach, following properties have been considered.

θ – Camera span

p – Distance of the camera from landslide

q – Coverage area of the camera

H - Height of image

When considering triangular properties, the results from two-dimensional image can be derived for the real-time analysis.

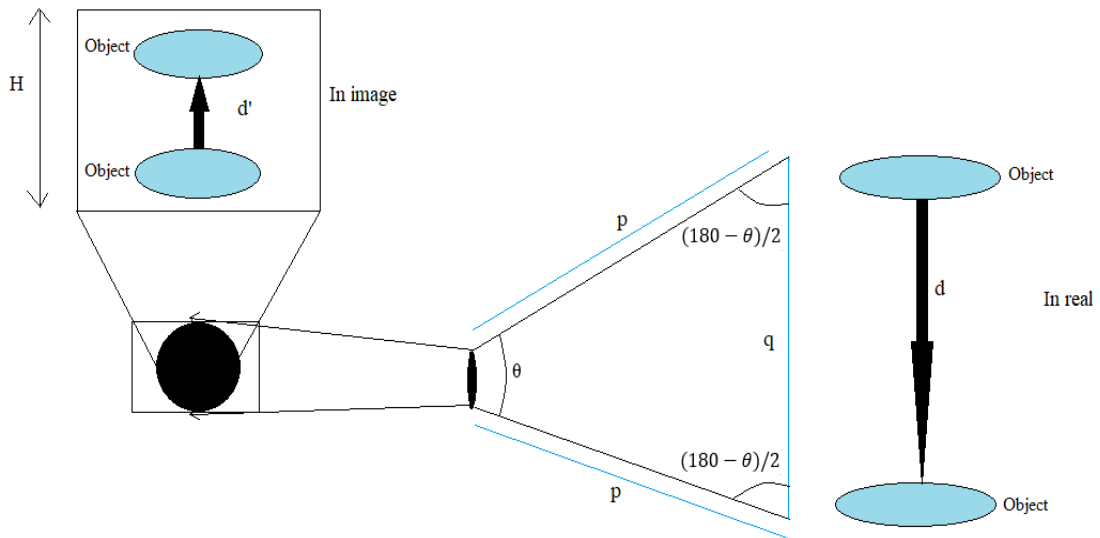

Figure 4.5: Mapping of 2-D image into real time system [33]

On considering figure 4.5, from the properties of triangle, below conclusions have been derived:

$$\frac{q}{\sin\theta} = \frac{p}{\sin((180-\theta)/2)} \dots\dots\dots (4.2)$$

Therefore,

$$q = \frac{p \times \sin\theta}{\sin(90-\frac{\theta}{2})} \dots\dots\dots (4.3)$$

In the real-time situation the movement of one pixel in a 2-D image can be derived by q/H. Thus, when the moving object shifts d` pixels in the image, its real-time displacement has been calculated as:

$$d = \left(\frac{q}{H}\right) \times d' \dots\dots\dots(4.4)$$

Where, d` - pixel movement of marker in image

q - coverage area of camera

H – height of the image

d – displacement of marker in real

The time from the incident when object identified to the time it disappeared from the frame has been calculated. The calculated displacement has been further used to derive the velocity of moving object [33].

$$velocity = \frac{displacement}{time} \dots\dots\dots (4.5)$$

4.3 Experimental aspects of the proposed theory:

On the basis of technique discussed in primary approach, an experiment has been performed for the analysis of real-time landslide. In this experiment, three markers of same size, shape and colour have been fixed on a sliding zone of the experimental slope. The dimensions of slope and other specifications of soil have been measured. In this experiment, the process performed for the landslide detection was offline on image processing tool of MATLAB. When the rainfall started, first frame of the slope has been captured.



Figure 4.6: First captured frame of the landslide prone slope

A continues rainfall on the experimental set up triggered the slope to slide down and so, shifts in the position of the markers have been noticed. The camera captured images continuously till the time any of the marker left the frame.

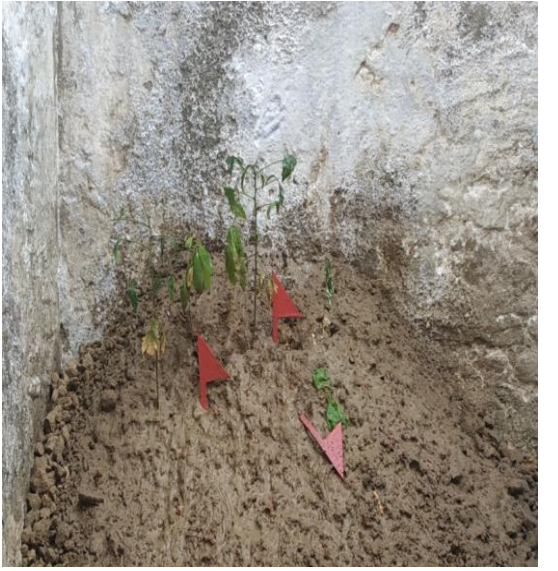
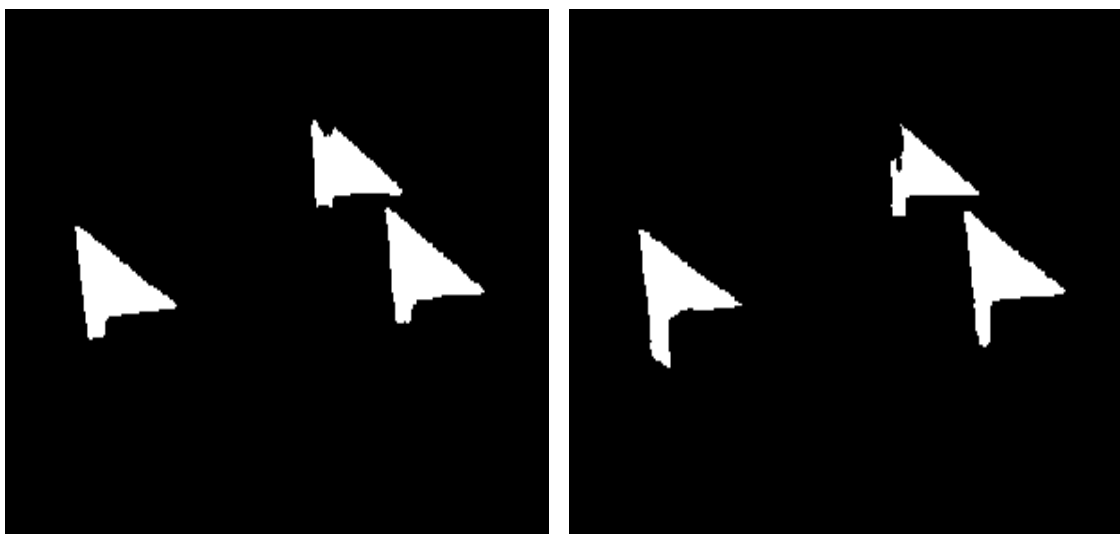



Figure 4.7: Shifting in position of markers with each passing frame

4.3.1 Steps taken in landslide detection during image processing:

- Step 1: Converting RGB image into Gray scale.
- Step 2: Extracting red colour component from RGB image.
- Step 3: Subtracting Gray scale image from red colour component of the RGB image.
- Step 4: Applying binary thresholding to convert Gray scale image into binary image.
- Step 5: Applying morphological function to extract out the markers.
- Step 6: Finding the number of markers.
- Step 7: Finding the centroid position of each of the markers.
- Step 8: By applying distance formula finding the displacement of the markers.
- Step 9: To measure the original shift the marker position, defining the camera specification.
- Step 10: Calculating the average velocity of the slide.



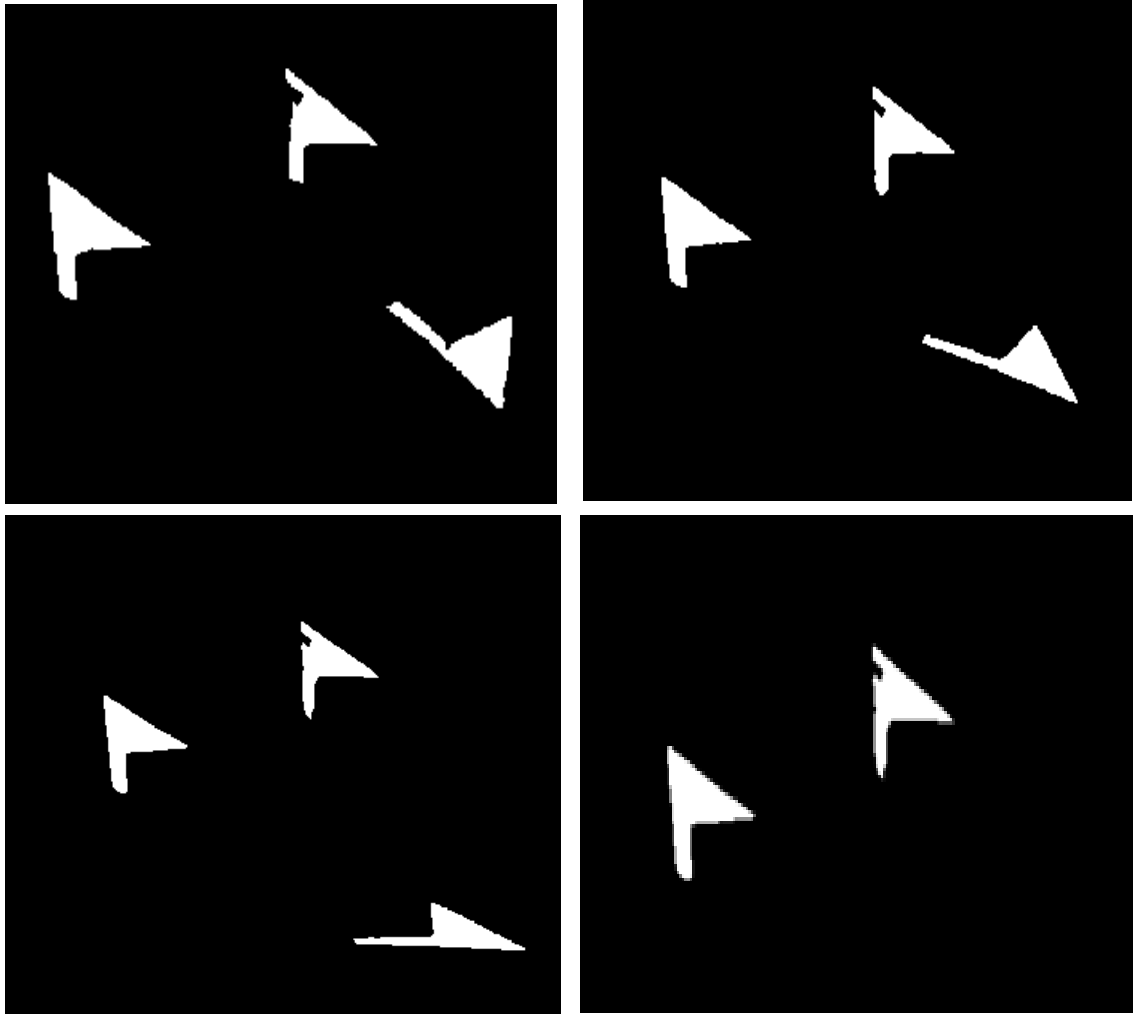
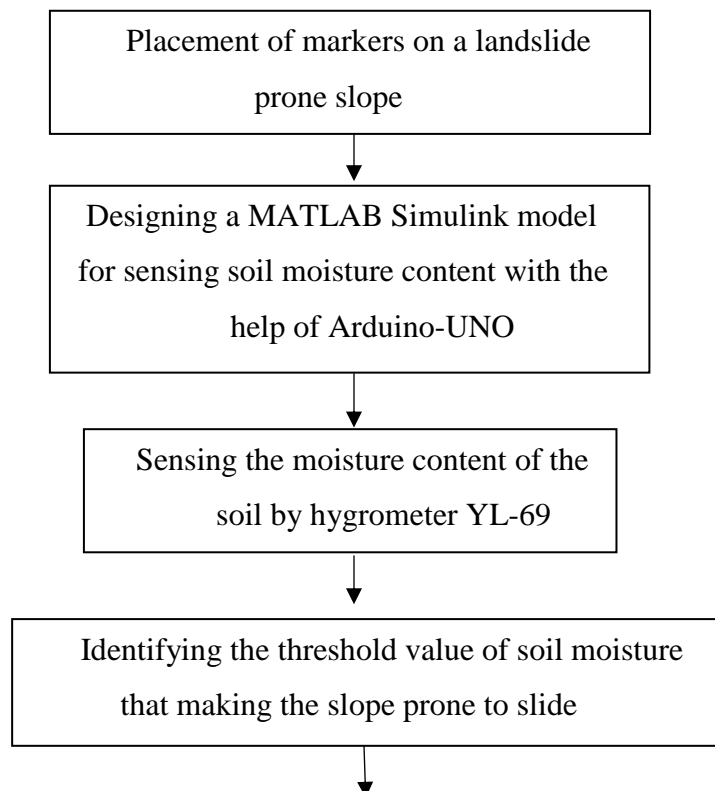

Figure 4.8: Detection of shifts in markers position

4.4 Designing of a real-time standalone landslide monitoring system:



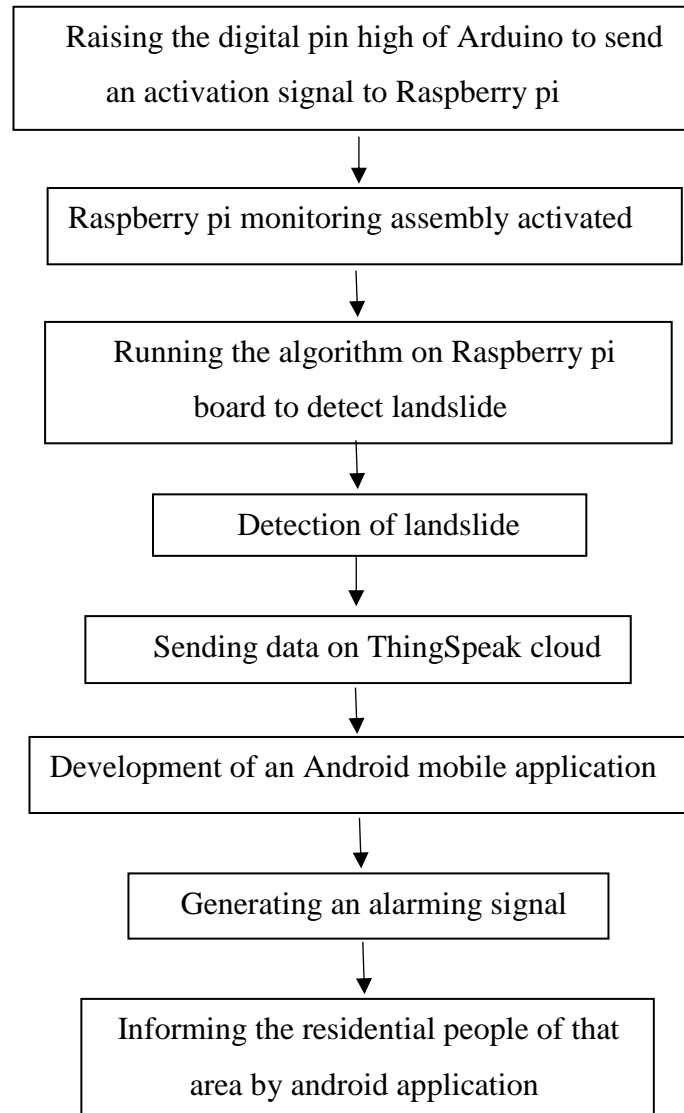

Figure 4.9: Flowchart of designing an early warning system for landslide

4.4.1 Placement of markers on a landslide prone area:

For the designing of an early warning landslide monitoring system with the help of Raspberry Pi, circular shaped markers of three different colours have been placed on landslide prone area. The shape of the markers has been chosen circular because of the function support available in MATLAB programming. For the easy detection, all markers were of different colours have been chosen.



Figure 4.10: Placement of markers on slope

4.4.2 Simulink model for sensing soil moisture content:

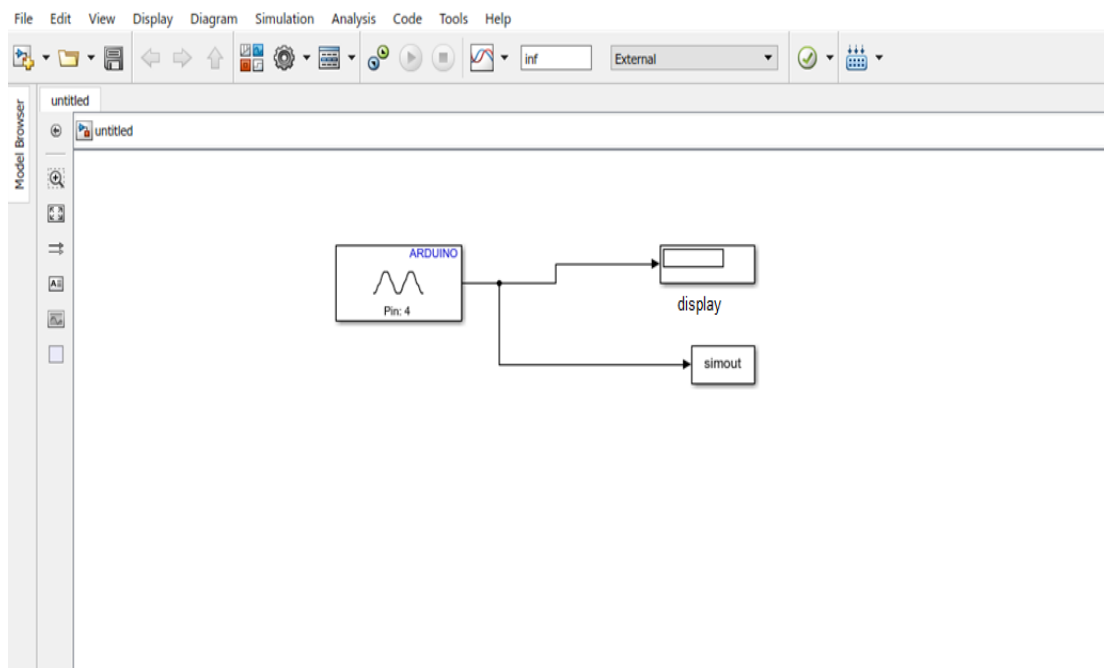

Figure 4.11: Simulink model for measuring the moisture content in soil

In this step, a MATLAB based Simulink model has been designed to measure the moisture content of the soil. The purpose of this step was to find that moisture value that triggers the slope to slide. The measured threshold value has been chosen as the activation signal to the monitoring assembly of landslide.

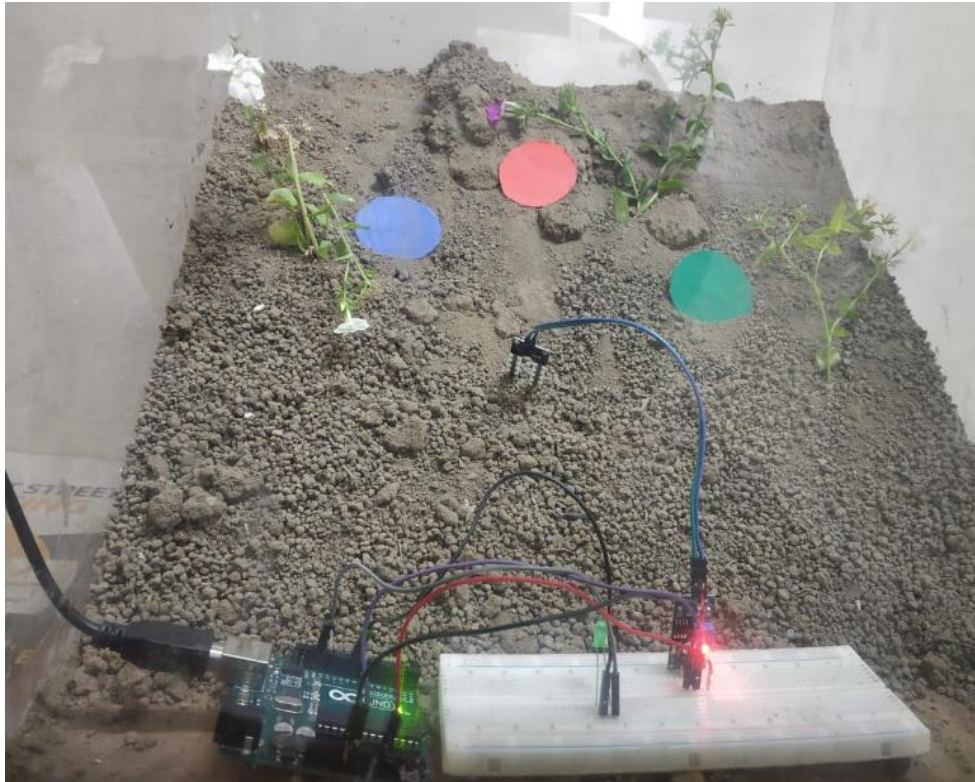

Figure 4.12: LED indication off when moisture value lesser than threshold



Figure 4.13: Generating an alarming signal that triggering landslide

4.4.3 Raspberry Pi monitoring assembly:

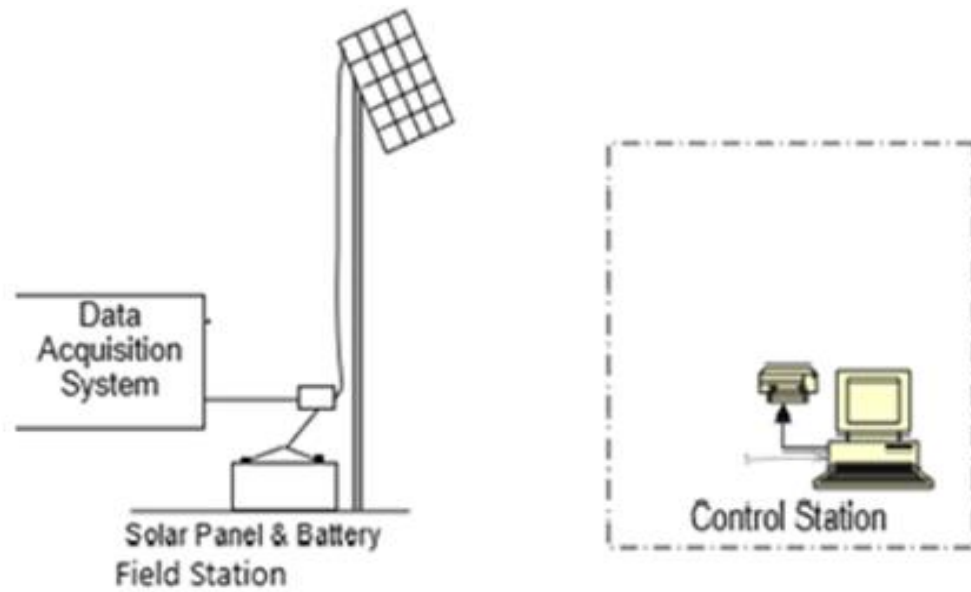

Figure 4.14: Block diagram of landslide monitoring assembly [47]

Figure 4.10 shows the landslide monitoring assembly. The field station assembly has been situated on a pole in front of landslide prone zone. The data acquisition system contained Raspberry Pi 3, Model B+ board along with C-140 USB camera. This assembly has been activated when the threshold signal from the Arduino triggers the Raspberry Pi pin high.



Figure 4.15: Activation of field station monitoring assembly

4.4.4 Detection of landslide:

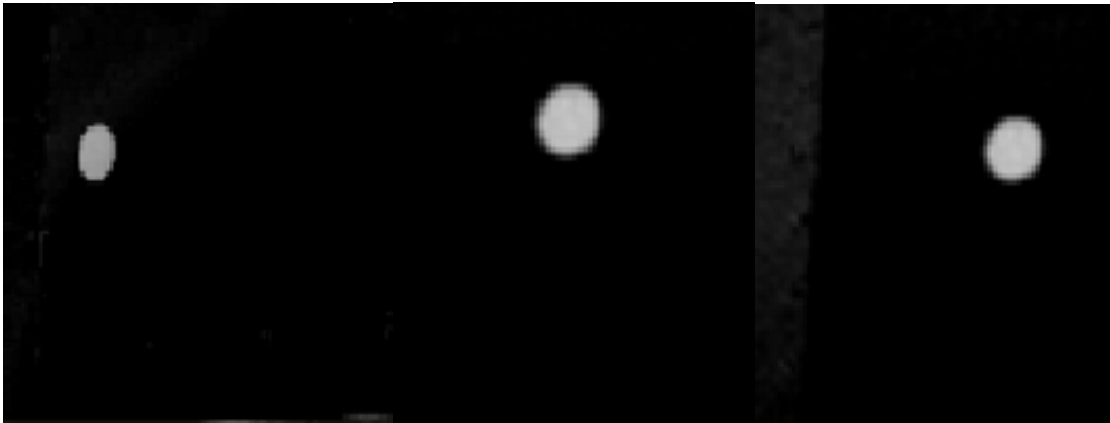

Figure 4.16: Detection of different markers in reference image

The threshold signal from the Arduino and YL-69 soil moisture sensor assembly activated the monitoring assembly at field station. Figure 4.16 shows the detection of all three markers in first captured frame which has been treated as the reference image for the comparison purpose with next consecutive frames.

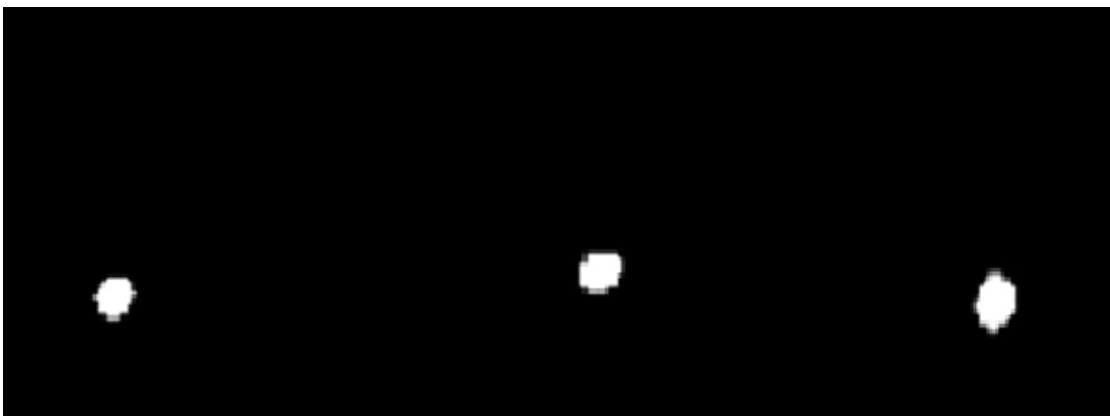

Figure 4.17: Displacement of markers from their original position

This comparison process has been continued till any one of these markers leave the frame. When one of the markers found missing from the picture, a signal has been generated.

4.4.5 Sending data to the cloud:

The generated signal from the above step has been updated on the ThingSpeak cloud to inform about the landslide. This website contained two different information. One was about alerting the landslide and other was about the velocity at which landslide is occurring.

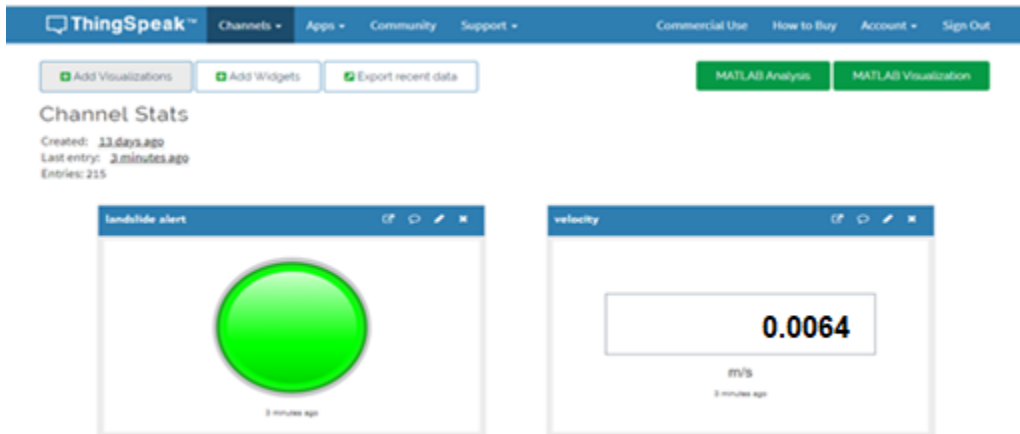

Figure 4.18: Sending landslide data on cloud

This information has been further used for the general-purpose access. Therefore, in the next step with the help of MATLAB an android based mobile application has been developed.

4.4.6 Development of an android mobile application:

Following steps have been taken place while making an android mobile application:

Step 1: Install hardware setup package for android device for interacting with android device.

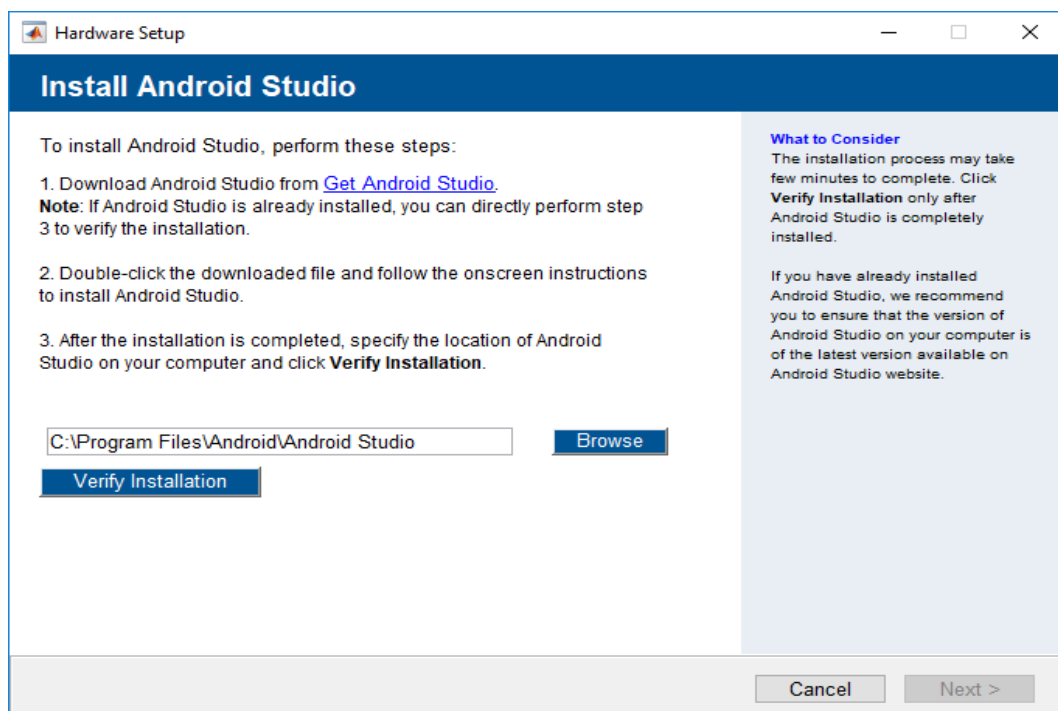

Figure 4.19: Simulink support packages for interacting Raspberry Pi with android devices

Step 2: Installing and verifying software development kit.

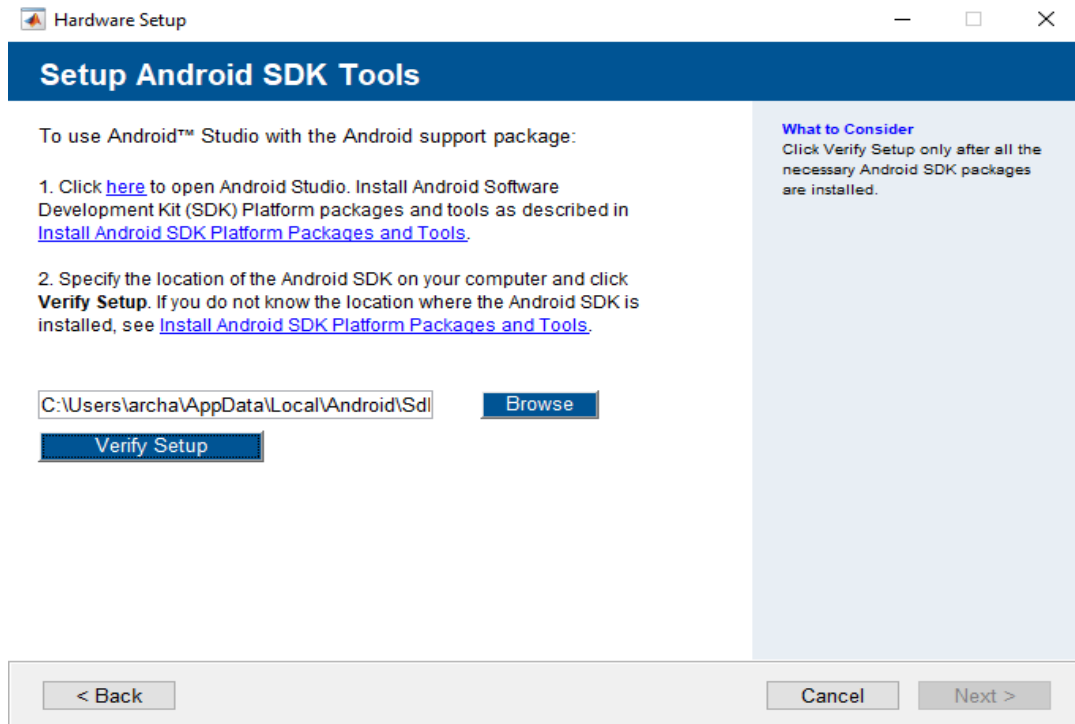

Figure 4.20: Android software development kit

Step 3: Installing the driver of the android phone and start debugging to access the phone remotely.

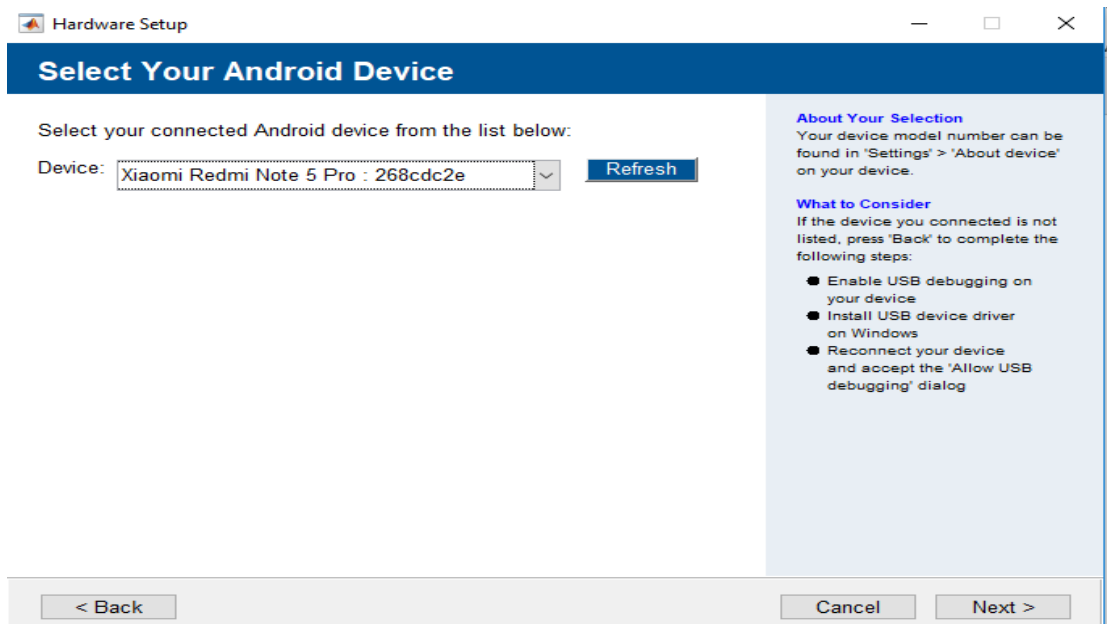

Figure 4.21: Driver installation of selected android device

Step 4: Configuring test application on the android device.



Figure 4.22: Configuring test application on the android device

TestApp
generated from Simulink

Network
 Name: "BTH5-c2Frc2hp"
 IPAddress: 192.168.43.149



Figure 4.23: Generating test application

Step 5: Developing android application:

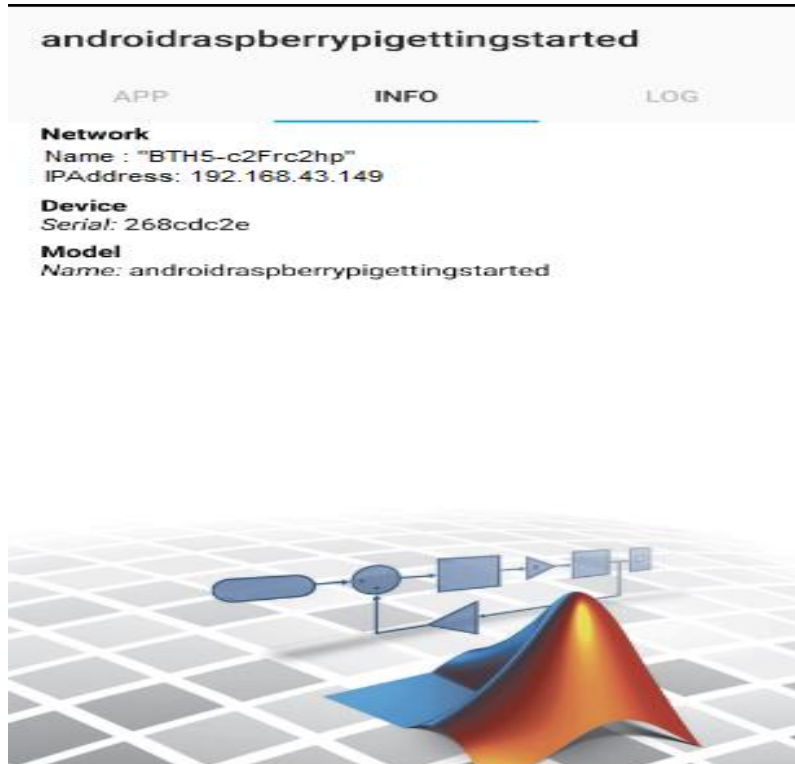

Figure 4.24: MATLAB based android application

Step 6: Landslide alert on android application

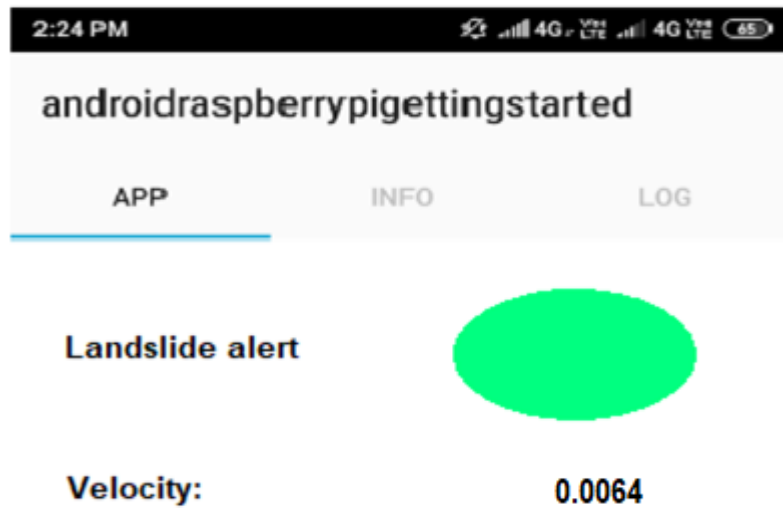

Figure 4.25: Alerting notification on android application

CHAPTER 5

RESULTS AND DISCUSSION

In this chapter, the results from the multiple experiments done for the analysis purpose of landslide have been discussed. On the basis of the results obtained from the analysis, a standalone landslide monitoring device has been designed. The entire process programming has been done on MATLAB programming software.

5.1 Results from primary approach of work:

In this experiment, the analysis has been done on an offline video of landslide and a marker has been fixed. With each passing frame, the position of marker has been noticed until the marker leave the frame. It was an experiment on offline data therefore some of the camera specifications were assumed.

The frame rate of the video was 30 frames/sec.

When assuming the camera span as 52° and the distance of object from camera location 50 m.

The coverage area in the pixel form was 43.837.

The height of the frame was 768 in pixels.

The calculated displacement in the form of pixel was 162.

Therefore, the real time derived displacement was found to be 9.253m.

The time taken in landslide process was 128 sec.

So that, the calculated velocity for this event found to be 0.0722 m/sec

5.2 Results from recorded data of a real-time experiment:

In this experiment, the analysis has been done on an experimental set-up of landslide of slope height 1 feet or 30.48 cm and data has been recorded by a still mobile camera. A continues rain on this slope triggered the landslide. The results from this experiment were as follows:

The frame rate of the video was 27 frames/sec.

The distance between camera and slope was 1 m.

The height above which camera situated on the ground was 0.2794 m.

The height of the frame was 3000 in pixels.

The average calculated displacement in the form of pixel was approximately 351 pixels.

Therefore, the actual average displacement found from the shifting of all three markers was found 0.098 m.

The time taken in landslide process was 40 seconds.

So that, the calculated velocity for this event is found to be 0.00247 m/sec or 0.247 cm/sec.

5.3 Results from real-time standalone system:

In this experiment, the analysis has been done by a real-time standalone monitoring system. In the first part of experiment, the soil-moisture sensor YL-69 with the Arduino assembly sensed the moisture content of the soil. Multiple experiments have been done to find the threshold value of soil moisture sensor that triggered the slope to slide down.

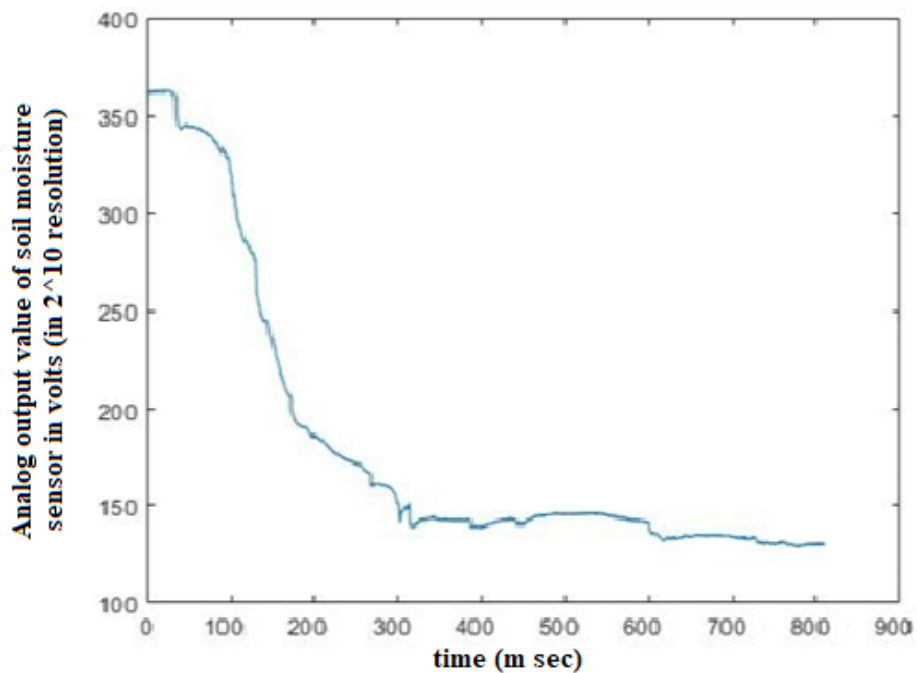

(a) Variation in output analog value of hygrometer in first experiment wrt time

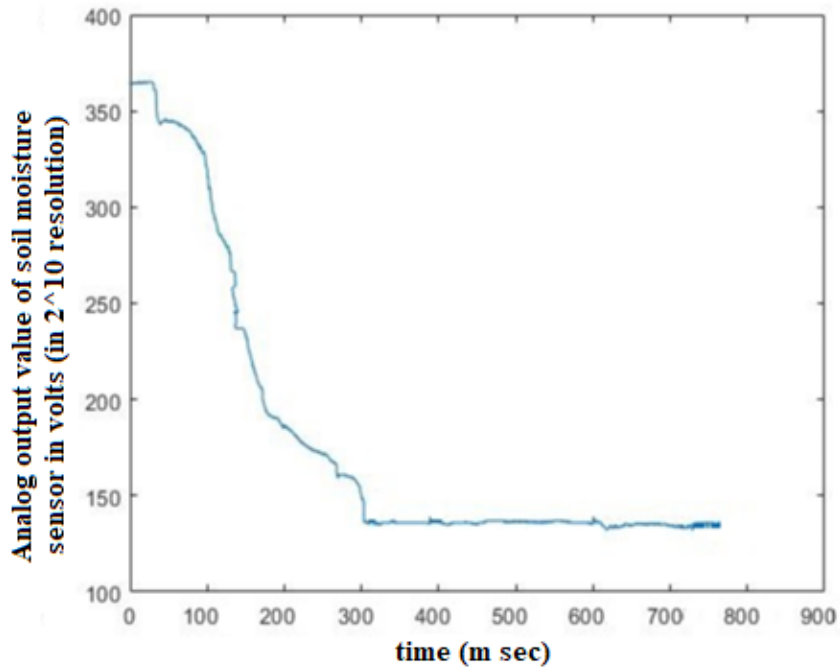

(b) Variation in output analog value of hygrometer in second experiment wrt time

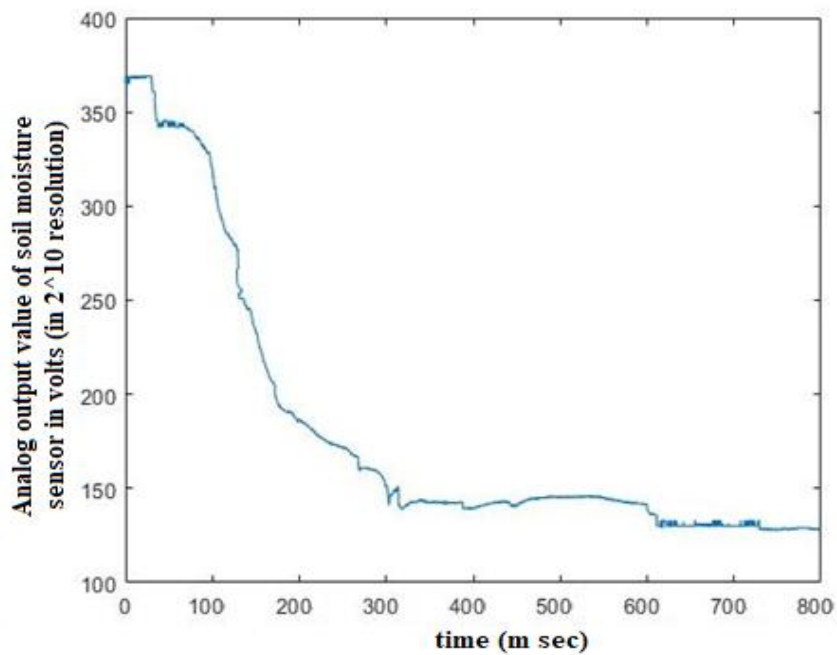

(c) Variation in output analog value of hygrometer in third experiment wrt time

Figure 5.1: Responses of soil moisture sensor with respect to time

From the multiple experiments it has been found that when the analog value of soil moisture sensor reached below 150, it became prone to landslide. At this point, the moisture percentage of the soil found to be nearly 85 percent. This analog value of soil moisture has been considered as the signal that activated the Raspberry Pi monitoring

assembly. When the standalone system activated it captured the first image of the monitoring zone as reference image and when any of the marker left the frame, it transferred the calculated results on cloud.

The frame rate was 30 frames/sec.

The distance between camera and slope was 1m.

The height of the frame was 800 in pixel.

The measured average displacement was 0.96 m.

The time taken for any one of the markers to leave the frame was 122 sec.

Therefore, the calculated velocity for this event found to be 0.64 cm/sec.

CHAPTER 6

CONCLUSION AND FUTURE SCOPE

6.1 Conclusion:

Landslide is a life-threatening issue. The increased amount of moisture content in the soil decreases the slope strength and so triggers the landslide. Therefore, in India most of the landslide occurs in rainy season. In this thesis work, the area of study considered was of Uttarakhand region. Many people lose their lives and homes in this area because of landslide every year. In order to solve this issue an idea has been presented in this thesis work to save their lives with the help of an early warning landslide monitoring system. For this purpose, a digital image processing algorithm based standalone monitoring system has been designed with the help of Raspberry Pi 3, Model B+. This field assembly has been situated in front of the lab prototype of landslide. There were three markers fixed for noticing the change of pattern in the slope. The data then have been transferred to the ThingSpeak cloud and further to a MATLAB based android mobile application. However, there were some limitation found in this project. The placement of markers on a real landslide prone slope is a bit difficult task. The present work was based on MATLAB based algorithm and due to lack of Raspberry Pi support functions in MATLAB the system can work only on circular shape markers. Sometimes, variation in light intensity of markers can also affect the processing.

6.2 Future scope:

The designed technique can be used to implement as a standalone monitoring system for an actual landslide prone mountain. The present work was done on a lab prototype therefore parameters of variation in results were less but when dealing with a real mountain, there will be many more issues to deal. The present algorithm can only be implemented with circular shape markers. In future, with the updates in Raspberry Pi support function, this issue can be removed out. The markers used for now were of different colours. But when dealing with a real time scenario, more than three markers will be needed. Therefore, in the future work markers of single colour and different numbering on them can be implemented. With the help of template matching, all the markers can be extracted out and further algorithm can be carried out easily. In the future work, the safety of devices involved can also be a concern of research.

REFERENCES

- [1] Jagdish. (2016). “Natural disaster Landslides” [PowerPoint slides]. Available at: <https://www.slideshare.net/jagadish108/unit-ii-landslide> [Accessed 5 December 2018].
- [2] M. J. Froude and D. N. Petley, “Global fatal landslide occurrence from 2004 to 2016”. *Natural Hazards Earths Systematic Sciences* 18. pp, 2161–2181, August 2018.
- [3] K. Ray, “India tops the world in landslide deaths”, *Deccan Herald news services*, para .1, August 24, 2018. [Online]. Available: <https://www.deccanherald.com/national/india-tops-world-landslide-689244.html>. [Accessed November 28, 2018].
- [4] P. Chaturvedi, S. Shrivastava and P. Kaur, “Landslide early warning system development using statistical analysis of sensor’s data at Tangni landslide, Uttarakhand, India”, *Advances in Intelligent System and Computing, Springer International Publishing*, pp. 547, April 2017.
- [5] R. Hakro. (2018). “Landslides Geology Lectures” [PowerPoint slides]. Available at: <https://www.scribd.com/presentation/377578085/Landslides-Geology-Lecture> [Accessed 5 Dec. 2018].
- [6] X. Meng, “Landslide”, *Encyclopaedia Britannica*, April 24,2017. [Online]. Available at: <https://www.britannica.com/science/landslide>. [Accessed May 19, 2019].
- [7] “Translational slides”, *British Geological Survey*. [Online]. Available at: <https://www.bgs.ac.uk/discoveringGeology/hazards/landslides/translational-slides-1.html> [Accessed May 19, 2019]
- [8] S. L. Kramer (2013) “Lateral Spreading. In: Bobrowsky P.T. (eds) *Encyclopaedia of Natural Hazards. Encyclopaedia of Earth Science Series*. Springer, Dordrecht”. Available at: https://link.springer.com/reference-worken-try/10.1007%2F978-1-4020-4399-4_215 [Accessed May 19, 2019]
- [9] H. M. King. “What is debris flow”, *Geology.com* [Online]. Available at: <https://geology.com/articles/debris-flow/> [Accessed May 19,2019]

- [10] L. Highland. “Landslides types and processes”, *USGS science for changing world*, July 2004. [Online]. Available at: <https://pubs.usgs.gov/fs/2004/3072/> [Accessed May 19, 2019]
- [11] M. H. K. Bulmer. (2014) “Topple”, *Encyclopedia of Planetary Landforms*. [Online]. Available at: https://link.springer.com/content/pdf/10.1007%2F978-1-4614-9213-9_379-1.pdf [Accessed May 19, 2019]
- [12] “List of worst landslides in India”, *India Today*, July 20, 2015. [Online]. Available at: <https://www.indiatoday.in/education-today/gk-current-affairs/story/landslides-india-283441-2015-07-20> [Accessed May 19, 2019]
- [13] S. K. Paul, S. K. Bhartarya, P. Rautela, A. K. Mahajan. “Catastrophic mass movement of 1998 monsoons at Malpa in Kali Valley, Kumaun Himalaya (India)”, *Geomorphology*, vol. 35, no. 3-4, pp.169-180, November 2000.
- [14] M. L. Islam, S. L. Chatteraj, P. K. R. Champaty. “Ukhimath landslide 2012 at Uttarakhand, India: Causes and consequences”, *International journal of geomatics and geosciences*, vol. 4, no. 3, pp. 544-557, 2014
- [15] A. K. Gupta, T. S. Roy. “Uttarakhand disaster 2013, Lessons learnt”, [Power-Point slides]. Available at: <https://nidm.gov.in/easindia2014/err/pdf/session/5/1.pdf> . [Accessed May 22, 2019]
- [16] “Landslides, heavy rains claim 27 lives in Sikkim, Assam”, *NDTV*, para .1, September 24, 2012 [Online] Available at: <https://www.ndtv.com/india-news/landslides-heavy-rains-claim-27-lives-insikkim-assam-500031>. [Accessed May 22, 2019]
- [17] A. Ali. “38 killed, 23 missing as landslide rock Darjeeling”, *The Indian Express*, para .1, May 22, 2019 [Online] Available at: <https://indianexpress.com/article/india/westbengal/landslides-claim-18-lives-in-darjeeling/> [Accessed May 22, 2019]
- [18] P. R. Mutthu and C. Muraleedharan. “Causes and Mechanism of Amboori Landslide of 9th November, 2001, Thiruvananthapuram District, Kerala”, *I-scholar*, vol. 66, no. 2, pp. 203-208, August 2005
- [19] S. M. Sarvade, M. M. Sarvade, P. S. Khadatare and M. R. Kolekar. “30/7 malin landslide: a case study”, in proceedings of national conference held GEPSID, Ludhiana October 12, 2014. pp. 691-698
- [20] B. Casson, C. Delacourt, D. Baratoux and P. Allemand, “Seventeen years of the ‘LaClapie`re’ landslide evolution analysed from ortho-rectified aerial photographs”, *Engineering Geology*, vol. 68, pp.123-139, 2003.

- [21] M. Scaioni, L. Longoni, V. Melillo and M. Papini, “Remote Sensing for Landslide Investigations: An Overview of Recent Achievements and Perspectives”, *Remote Sensing*, vol. 6, no. 10, pp. 9600-9652, 2014
- [22] J. McKean and J. Roering, “Objective landslide detection and surface morphology mapping using high-resolution airborne laser altimetry”, *Geomorphology*, vol. 57, no. 3, pp. 331-351, February 2004
- [23] D. Huntley, P. Bobrowsky, Q. Zhang, X. Zhang and Z. Lv. 2017. “Fibre Bragg grating and Brillouin optical time domain reflectometry monitoring manual for the Ripley Landslide, near Ashcroft, British Columbia”, *Geological Survey of Canada*, Open File 8258, 66 p. [Online] Available: <https://doi.org/10.4095/304235> [Accessed May 20 2019].
- [24] M. E. Reid, R. G. LaHusen and W. L. Ellis. “Real time monitoring of active landslide along highway 50, E1 Dorado Country”, *California Geology*, vol. 51, no. 3, pp. 17-20, 1998
- [25] B. Silvia, C. Francesca, D. V. Chiara, M. Sandro, C. Nicola. “Monitoring Landslide- Induced Displacements with TerraSAR-X Persistent Scatterer Interferometry (PSI): Gimigliano Case Study in Calabria Region (Italy)”, *International Journal of Geosciences*, vol.4, no.10, pp. 1467-1482, 201
- [26] G. Rossi, L. Catani, L. Leoni, S. Segoni and V. Tofani. “HIRESSES: a physically based slope stability simulator for HPC applications”, *Natural hazards and earth system sciences*, vol. 13, no. 1, pp. 151- 166, January 25, 2013.
- [27] P. Mercogliano, S. Segoni, G. Rossi, B. Sikorsky, V. Tofani, P. Schiano, F. Catani and N. Casagli. “Brief communication: A prototype forecasting chain for rainfall induced shallow landslides”, *Natural Hazards and Earth System Sciences*, vol. 13, no. 3, pp. 771-777, March 25, 2013.
- [28] T. Carla, E. Intrieri, F. D. Traglia, T. Nolesini, G. Gigli and N. Casagli. “Guidelines on the use of inverse velocity method as a tool for setting alarm thresholds and forecasting landslides and structure collapses”, *Journal of the International Consortium on Landslides*, vol. 14, no. 2, pp. 517-534, April 2017
- [29] S. C. Stiros, C. Vichas and C. Skourtis. “Landslide monitoring based on geodetically derived distance changes”, *journal of surveying engineering*, vol. 130, no. 4, pp. 156- 162, 2004.

- [30] S. K. Mittal, M. Singh, P. Kapur, B. K. Sharma and M. A. Shamshi. “Design and development of instrumentation network for landslide monitoring and issue an early warning”, *Journal of scientific and industrial research*, 67, pp. 361-365, May 2008.
- [31] D. P. Kanungo. “Ground Based Real Time Monitoring System Using Wireless Instrumentation for Landslide Prediction”, *Landslides: Theory, Practice and Modelling, Advances in Natural and Technological Hazards Research*, vol. 50, pp 105-120, June 29, 2018.
- [32] U. Niethammer, S. Rothmund, U. Schwaderer, J. Zeman, M. Joswig. “Open source image-processing tools for low-cost uav-based landslide investigations”, *International Archives of the Photogrammetry, Remote Sensing and Spatial Information Sciences*, vol. 28, pp. 161-166, 2011.
- [33] P. K. Mishra, P. Chaturvedi, N. Tyagi, P. N. Joglekar. “Real time landslide monitoring and estimation of its movement velocity”, *ICRCICN*. Kolkata, India. November 2014, pp. 335-339.
- [34] P. Chaturvedi, K. K. Thakur, N. Mali, V. Uday, S. Kumar, S. Yadav and V. Dutt. “A Low-Cost IoT Framework for Landslide Prediction and Risk Communication”, *Internet of Things A to Z: Technologies and Applications*. vol. 1, pp. 593-610, May 2018.
- [35] “YL-69 soil hygrometer humidity & soil moisture detection sensor”. [Online] Available at: <https://www.oddwires.com/yl-69-soil-hygrometer-humidity-soil-moisture-detection-sensor/> [Accessed May 27,2019]
- [36] “Soil Moisture Sensor Interfacing with Arduino UNO”. [Online] Available at: <https://www.electronicwings.com/arduino/soil-moisture-sensor-interfacing-with-arduino-uno> [Accessed May 28, 2019]
- [37] “Introduction to Arduino UNO”. [Online] Available at: https://en.wikipedia.org/wiki/Arduino_Uno [Accessed May 28,2019]
- [38] “Arduino- board description”. [Online] Available at: https://www.tutorialspoint.com/arduino/arduino_board_description.htm [Accessed May 29, 2019]
- [39] “Introduction to Raspberry Pi 3 B+”. [Online] Available at: <https://www.theengineeringprojects.com/2018/07/introduction-to-raspberry-pi-3-b-plus.html> [Accessed May 29, 2019]

- [40] “Raspberry Pi 3 Model B+”. [Online] Available at: <https://static.raspberrypi.org/files/product-briefs/Raspberry-Pi-Model-Bplus-Product-Brief.pdf> [Accessed May 29, 2019]
- [41] M. D. Okoi. “10 operating system you can run on raspberry pi in 2019”. [Online] Available at: <https://www.fossmint.com/operating-systems-for-raspberry-pi/> [Accessed May 29, 2019]
- [42] “Logitech HD webcam C270 technical specifications”. August 31,2014. [Online] Available at: https://support.logitech.com/en_us/article/17556 [Accessed May 29, 2019]
- [43] “Soil”. *Web India 123*. [Online] Available at: <https://www.webindia123.com/Punjab/land/soil.html> [Accessed May 31,2019]
- [44] “Fluence of parent material and soil on the floristic composition of Mussoorie hill”. [Online] Available at: https://shodhganga.inflibnet.ac.in/bitstream/10603/176153/6/06_chapter%201.pdf [Accessed May 31, 2019]
- [45] S. Aggarwal, K. V. S. Kumar, P. K. Mishra and P. Chaturvedi. “Landslide monitoring system implementing IOT using video camera”, 2018 3rd I2CT. Pune, India, April 08, 2018.
- [46] K. X. Su. “20160715 Field Experiment of Landslide Dam Breaching in Huisun Forest”, Nov 20, 2016. Accessed on: September 1, 2018. [Video file]. Available at: <https://www.youtube.com/watch?v=8DRqxo-CeUT0&t=2s&pbjreload=10>
- [47] S. K. Mittal, “A Technical note on monitoring of Jhakri landslide in Bari village area of Himachal Pradesh”, *Journal of Rock Mechanics and Tunneling Tech.* Vol. 19 No. 2, pp. 129-134. May 2013.

ORIGINALITY REPORT

10%

SIMILARITY INDEX

4%

INTERNET SOURCES

3%

PUBLICATIONS

8%

STUDENT PAPERS

PRIMARY SOURCES

1	Submitted to Thapar University, Patiala Student Paper	1%
2	tudr.thapar.edu:8080 Internet Source	<1%
3	baadalsg.inflibnet.ac.in Internet Source	<1%
4	pt.scribd.com Internet Source	<1%
5	Submitted to Universiti Tenaga Nasional Student Paper	<1%
6	"Landslides: Theory, Practice and Modelling", Springer Nature, 2019 Publication	<1%
7	Submitted to MCI Management Centre Innsbruck Student Paper	<1%
8	www.antiessays.com Internet Source	<1%
