

***THESIS***

***On***

**DISEASE DIAGNOSTIC SYSTEM USING LabVIEW**

***Submitted in the partial fulfillment of the requirement for the award of degree of***

**Master of Engineering**

**in**

**Electronics Instrumentation & Control Engineering**



***Submitted by***

**Deepanshu Goyal**

Roll No: 8044208

***Under Esteemed Guidance of***

**Mr. Sunil Kumar Singla**

Senior Lecturer,

EIED,

TIET, Patiala

**JUNE 2006**

**Electrical and Instrumentation Engineering Department  
THAPAR INSTITUTE OF ENGINEERING AND TECHNOLOGY  
(DEEMED UNIVERSITY)  
PATIALA (PUNJAB) -147004**

# ACKNOWLEDGEMENT

---

*First of all I would like to thank the Almighty, who has always guided me to work on the right path of the life.*

*I am very thankful to the Head of the Department, Mrs. Manbir Kaur, for her encouragement, support and for providing the facilities for the completion of this thesis.*

*This work would not have been possible without the encouragement and able guidance of my supervisor Mr. Sunil Kumar Singla. His enthusiasm and optimism made this experience both rewarding and enjoyable. Most of the novel ideas and solutions found in this thesis are the result of our numerous stimulating discussions. His feedback and editorial comments were also valuable for writing this thesis.*

*I am very grateful to all the doctors who spared their valuable time to help me in this thesis.*

*I am also very thankful to the entire faculty and staff members of Electrical Instrumentation Department for their direct–indirect help, cooperation, love and affection which made my stay at TIET memorable.*

*I am deeply indebted to my parents for their inspiration and ever encouraging moral support, which enabled me to pursue my studies.*

**Dated:**

**DEEPANSHU GOYAL**

**(ROLL NO. 8044208)**

## CLAIM OF ORIGINALITY

---

*This is to certify that the work presented in this thesis entitled “Disease Diagnostic System Using LabVIEW” submitted by Mr. Deepanshu Goyal in partial fulfillment of the requirement for the award of the degree of Master of Engineering in Electronics Instrumentation and Control Engineering at Thapar Institute of Engineering and Technology (Deemed University), Patiala, is an original record of the candidate’s own work carried by him under supervision and guidance of Mr. Sunil K. Singla..*

*The matter embodied in this report has not been submitted in any other University/ Institute for the award of any degree.*

*(Sunil K. Singla)*

*Senior Lecturer,  
EIED,  
TIET,  
Patiala, 147004*

*(Manbir Kaur)*

*Head,  
EIED  
TIET,  
Patiala, 147004*

*(Dr. T. P. Singh)*

*Dean of Academic Affairs,  
Thapar Institute of Engineering & Technology,  
Patiala- 147004*

# CLAIM OF AUTHENTICITY

---

---

*This is to certify that the work presented in this thesis entitled “Disease Diagnostic System Using LabVIEW” submitted by Mr. Deepanshu Goyal in partial fulfillment of the requirement for the award of the degree of Master of Engineering in Electronics Instrumentation and Control Engineering at Thapar Institute of Engineering and Technology (Deemed University), Patiala, is an authentic record of the candidate’s own work carried by him under the supervision and guidance of Mr. Sunil Kumar Singla.*

*The matter embodied in this report has practical significance and can be implemented by doctors to diagnose various types of anemia.*

*(Dr. Pramod Mittal)*  
*MBBS, MD (Medicine),*  
*DM (Gastroenterology)*

*(Dr. Sudhir Verma)*  
*MBBS, MD (Medicine),*  
*DM (Cardiology)*

*(Dr. Rakesh Arora)*  
*MBBS, MD (Medicine)*

*(Dr. Neeraj Goyal)*  
*Consultant Physician*

# Abstract

---

The most challenging problem troubling the world today is the spread of diseases and the consequent sufferings of the innocent inhabitants of this planet. The doctors and researchers all over the world work, jointly and separately, day and night to combat this grave problem to the maximum extent they can. In spite of this conscious and collective effort mistakes do occur and sometimes these prove to be highly fatal. Most of the times the mistakes are due to wrong diagnosis, the starting step towards implementing a cure. Engineer can contribute in this field by developing a software or computer program, called Expert System, which can aid the doctor in diagnosing a disease. This expert system will surely bring down the mistakes which in turn will be a boon for humanity. One such system to diagnose various kinds of anemias, using the concept of fuzzy logic on LabVIEW platform, has been attempted by us in this research.

Our present work presents the design and development of a prototype expert system for clinical diagnosis by applying fuzzy set theory to inference process and knowledge representation. The design aligns the structure and work of the diagnosis mechanism similarly to the decision –making process of a physician by dividing the diagnosis in to two parts. The first part of the diagnosis is to find the group of diseases using fuzzy inference and the fuzzy knowledge base. The second part is to find a disease using the knowledge base.

The rule base and the fuzzy sets are developed after consultation with doctors in Patiala. The system has been designed keeping in mind the critical criterions of user friendliness, high speed of execution and easy modifiability in case of any need.

# Table of Contents

---

Acknowledgement	i
Claim of Originality	ii
Claim of Authenticity	iii
Abstract	iv
Table of Contents	v - viii

<b>Topic No.</b>	<b>Description</b>	<b>Page</b>
<b>CHAPTER 1:</b>	<b>INTRODUCTION</b>	<b>1 - 4</b>
1.1	Common Signs and Symptoms of Anemia	2
1.2.	Diagnosis of Anemia	2 - 3
1.3	Definition of the Problem	3 - 4
<b>CHAPTER 2:</b>	<b>ANEMIA AND ITS TYPES</b>	<b>5 - 23</b>
2.1	Basics to Understand Anemia: Blood	5 - 8
2.1.1	Anatomy of Blood	6 - 7
2.1.2	Physiology of Blood	7 - 8
2.2	Types of Anemia	9 - 23
2.2.1	Anemias of Blood Loss	11 - 12
2.2.2	Hemolytic Anemias	12 - 18
2.2.3	Impaired Red Cell Production	19 - 23
<b>CHAPTER 3:</b>	<b>FUZZY LOGIC AND LabVIEW</b>	<b>24 - 37</b>
3.1	What is Fuzzy Logic	24 - 33
3.1.1	Foundations of Fuzzy Logic	25 - 31
3.1.2	Advantages of Fuzzy logic	32
3.1.3	When not to use Fuzzy logic	32
3.1.4	Fuzzy Expert System	32 - 33

3.2	What is LabVIEW	34 - 37
3.2.1	Features of LabVIEW	34 - 36
3.2.2	Advantages of LabVIEW	36 - 37
<b>CHAPTER 4: SOFTWARE IMPLEMENTATION</b>		<b>38 - 53</b>
4.1	Fuzzy Logic System for Anemia Detection	38
4.2	Fuzzy subsets	38 - 42
4.3	12 Input Fuzzy control system in LabVIEW	42 - 49
4.3.1	Input Values	44
4.3.2	Fuzzification	45 - 47
4.3.3	Rule Base	48
4.3.4	Defuzzification	49
4.4	Sub VIs used	49 - 57
4.4.1	Fuzzification Sub VI	49 - 51
4.4.2	Rule Base Sub VI	51 - 53
<b>CHAPTER 5: RESULTS AND CONCLUSIONS</b>		<b>54 - 65</b>
5.1	Result 1	54 - 62
5.1.1	Input Values	54 - 60
5.1.2	Fuzzification	60
5.1.3	Rule Base	61
5.1.4	Defuzzification and Diagnosis	61 - 62
5.2	Result 2	63
5.3	Result 3	64
5.4	Conclusion	65
5.5	Scope of Future work	65
<b>Appendix</b>		<b>66</b>
Appendix I		66
<b>Glossary</b>		<b>67 - 69</b>
<b>References</b>		<b>70 - 72</b>

# List of Tables and Figures

---

## List of Tables

<b>Table No.</b>	<b>Description</b>	<b>Page</b>
2.1	Types of Anemia	10 - 11
4.1(a-l)	Membership values of various Fuzzy subsets for different inputs	38 - 42

## List of Figures

<b>Figure No.</b>	<b>Description</b>	<b>Page</b>
1.1	Anemia pattern with age in Benin, Madagascar, Mali and Uganda	1
2.1	Human Blood Smear	7
2.2 (a-b)	Hemolytic Anemia	13
2.3	Smear from a patient with Spherocytosis	15
2.4	Peripheral blood smear from a patient with G6DP deficiency	16
2.5	Sickle shaped RBCs in peripheral blood smear of a patient	17
2.6	RBCs in blood smear of a patient with Microangiopathic Hemolytic Anemia	18
2.7	Peripheral blood smear of a patient suffering from Megaloblastic Anemia	19
2.8	Bone marrow of a person suffering from Aplastic Anemia	20
2.9	Peripheral Blood smear of a patient showing Iron Deficiency Anemia	23
3.1	Illustration of Fuzzy Logic	24
3.2.	Concept of Fuzzy Inference System	25
3.3	Binary Set	26
3.4	Fuzzy Set	26
3.5 (a-b)	Binary v/s Fuzzy Values	27
3.6 (a-b)	Binary v/s Fuzzy Functions	28
3.7	Binary Logical Operators	29
3.8	Fuzzy Logical Operators	29

3.9	General architecture of a Fuzzy Expert System	33
4.1	Flowchart for the 12 input Fuzzy Control System in LabVIEW	43
4.2	Block Diagram for getting Inputs	44
4.3	Block Diagram for calling Fuzzification sub VI	45
4.4 (a-l)	Membership values of various Inputs	46 – 47
4.5	Block Diagram for calling Rule Base Sub VI	48
4.6 (a-b)	Block Diagram for Defuzzification	49
4.7	Flowchart for Fuzzification Sub VI	50
4.8	Front Panel for Fuzzification SubVI	51
4.9	Flowchart for Rule Base Sub VI	52
4.10	Front Panel for Rule Base SubVI	53
5.1 (a-l)	Front Panels for entering various Inputs	54-60
5.2	Fuzzification front panel for TIBC	60
5.3	Rule Base front panel for Rule 15	61
5.4	Result 1: High Megalobalstic Anemia	62
5.5	Result 2: High Aplastic Anemia	63
5.6	Result 3: Unrealistic Inputs	64

# Chapter 1

## Introduction

Anemia is a disease which affects almost every country in the world. It is the most widespread of the diseases and is responsible for 2% of the total casualties in the world each year [1]. Hence diagnosing and treating anemia is very critical in order to save people all over the world. Figure 1.1 shows the pattern of anemia in African countries of Benin, Madagascar, Mali and Uganda [1].

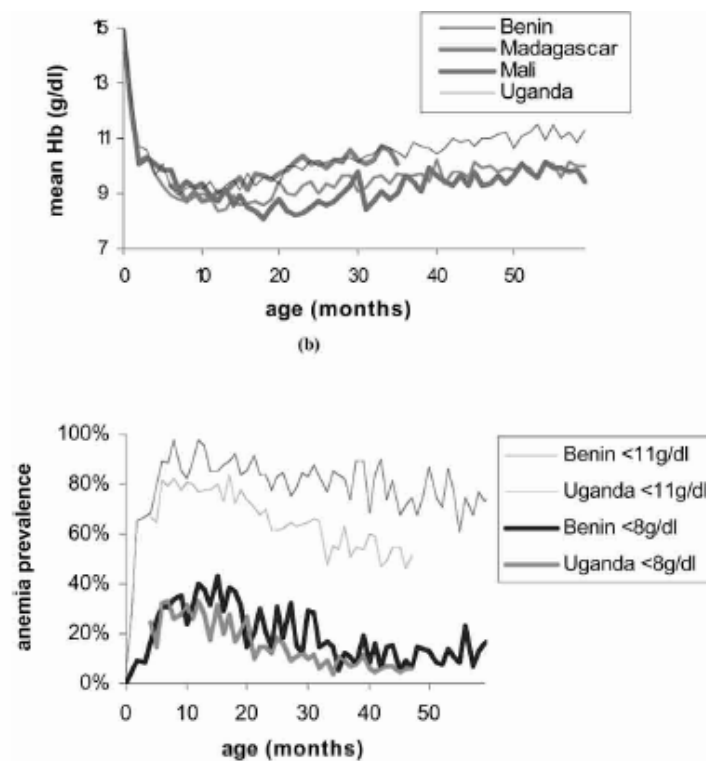

**Figure 1.1: Anemia pattern with age in Benin, Madagascar, Mali and Uganda**

This shows that more than 80% of the infants 10 months of age are anemic. Similar results were obtained from Kenya, Tanzania and Malawi [1]. In fact chronic anemias are prevalent in all the countries of the world in one form or another of which iron deficiency anemia is the most common [1,4,22].

## **1.1 Common Signs and Symptoms of Anemia**

Anemia is a condition in which the body does not have enough red blood cells [22]. As anemia is a hematologic condition [28], a simple blood test called complete blood count (CBC) is standard and crucial to diagnosis [17, 19]. It measures the levels or counts of the different types of cells in the blood, including white blood cells and platelets.

Anemia goes undetected in many people, and symptoms can be vague [6, 11]. Most commonly, people with anemia report a feeling of weakness or fatigue. The skin is pale and usually becomes thin and inelastic as the epidermis and dermis atrophy. Frequently, the nails become brittle and lose their normal convexity to assume a concave spoon-shape, particularly in iron deficiency anemia [4]. People with more severe anemia sometimes report shortness of breath. Very severe anemia prompts the body to compensate by markedly increasing cardiac output, leading to palpitations and sweatiness; this process can lead to heart failure in elderly people [2, 3]. Pallor (pale skin and mucosal linings) is only notable in cases of severe anemia, and is therefore not a reliable sign. Cells that are particularly vulnerable to hypoxia may undergo fatty change or even ischemic necrosis. Such damage is most frequently encountered in the muscle cells of the myocardium, the epithelial cells of the proximal convoluted tubules of the kidney, the centrilobular hepatic cells, and the sensitive ganglion cells of the cortex and basal ganglia [22].

The increased demand for erythropoiesis in anemia causes the fatty marrow to become active and red if the marrow is capable of response. In some anemic states, such as aplastic anemia, the marrow can't react. When the need is great extra medullary hematopoiesis ensues, reverting to the fetal patterns of blood formation. Other more specific changes may also appear, determined by the particular type of anemia.

## **1.2 Diagnosis of Anemia**

The only way to definitively diagnose most cases of anemia is with a blood test [17]. Generally, clinicians order a full blood count. Apart from reporting the number of red blood cells and the hemoglobin level, the automatic counters also measure the size of the red blood cells by flow cytometry, which is an important tool in distinguishing between the causes of anemia. A visual examination of a blood smear can also be helpful in some cases, and is sometimes a necessity in regions of the world where automated analysis is less accessible. In modern counters, three parameters [22] (RBC Count, hemoglobin concentration and MCV) are measured, allowing others

(hematocrit, mean corpuscular hemoglobin and mean corpuscular hemoglobin concentration) to be calculated, and compared to values adjusted for age and sex. For males, the hemoglobin level that is suggestive of anemia is usually less than 13.0 g/dl, and for females, it is 12.0 g/dl.

Depending on the clinical philosophy, whether the hospital's automated counter can immediately add it to the initial tests, and the clinicians' attitudes towards ordering tests, a reticulocyte count may be ordered either as part of the initial workup or during follow-up tests [17]. This is nearly a direct measure of the bone marrow's capacity to produce new red blood cells, and is thus the most used method of evaluating the problem of production. This can be especially important in cases where both loss and a production problem may co-exist. Many physicians use the reticulocyte production index—a calculation of the ratio between the level of anemia and the extent to which the reticulocyte count has risen in response. Even in cases where an obvious source of loss exists, this helps evaluate whether the bone marrow will be able to compensate for the loss, and at what rate.

When the cause is not obvious, clinicians use other tests to further distinguish the cause for anemia. A clinician may also decide to order other screening blood tests that might identify the cause of fatigue; serum glucose, ESR, ferritin, serum iron, RBC folate level, serum vitamin B<sub>12</sub>, renal function tests (e.g. serum creatinine) and electrolytes may be part of such a workup.

Other characteristics visible on the peripheral smear may provide valuable clues about a more specific diagnosis; for example, abnormal white blood cells may point to a cause in the bone marrow [17].

### **1.3 Definition of the Problem**

Anemia is a highly widespread and common disease which can be fatal in many cases. Based upon the symptoms, diagnostic techniques and in consultation with many doctors, finally a total of 12 tests were taken to determine the kind of anemia. These tests along with their maximum and minimum values are given below:

- i. Hemoglobin (0-20 gram/100 L)
- ii. Hematocrit (20-45 % of blood sample taken)
- iii. Mean corpuscular volume (50-125 cubic microns)
- iv. Mean corpuscular hemoglobin concentration (20-45 % of erythrocyte)
- v. Reticulocyte count (0-10 %of erythrocytes)
- vi. White blood cells (500-15k nos /cubic mm)

- vii. Platelets (5K-900K nos /cubic mm)
- viii. Nucleated red cells ( 0-15 %rbc)
- ix. Serum Iron ( 10-250 microgram/dl)
- x. Total iron binding capacity ( 150-400 microgram)
- xi. Hyper segmented white cells (0-15 %rbc)
- xii. Ringed sideroblast in bone marrow (0-15 %rbc)

The present work has been undertaken as design and development of the anemia diagnostic system using LabVIEW (**L**aboratory **V**irtual **I**nstrumentation **E**ngineering **W**orkbench). Fuzzy set theory is used as a diagnostic tool. The assignment is divided into two parts:

1. Preparation of rule base and fuzzy sets
2. Implementation using LabVIEW platform

Care should be taken that the developed system is user friendly, flexible, fast and reliable. The developed system diagnoses the following 18 types of anemias:

- i. High Aplastic Anemia
- ii. Medium Aplastic Anemia
- iii. Low Aplastic Anemia
- iv. High Anemia chronic disease
- v. Medium Anemia chronic disease
- vi. Low Anemia chronic disease
- vii. High iron deficiency anemia
- viii. Medium iron deficiency anemia
- ix. Low iron deficiency anemia
- x. High sideroblast anemia
- xi. Medium sideroblast anemia
- xii. Low sideroblast anemia
- xiii. High mylophthisic anemia
- xiv. Medium mylophthisic anemia
- xv. Low mylophthisic anemia
- xvi. High megaloblast anemia
- xvii. Medium megaloblast anemia
- xviii. Low megaloblast anemia

## Anemia and Its Types

Human beings have two types of respiration: External and Internal [23, 24]. External Respiration is analogous to breathing but Internal Respiration takes place at the cellular level where the cells take up  $O_2$  from the blood and give off  $CO_2$  to the blood. This oxygen is used for many purposes e.g. to breakdown food products into other useful products (and also generates some waste products) releasing energy in the process, for muscle building etc. Thus internal respiration is important to ensure proper metabolic and catabolic activities in the body. All the more important is the  $O_2$  supplied to cells which in turn depend upon the  $O_2$  carrying capacity of blood. The blood contains RBCs (Red Blood Corpuscles) which in turn contain an  $O_2$  carrying pigment called Hemoglobin. Any harm to RBCs which reduces its  $O_2$  carrying capacity is very critical to the human body. This disease whereby the  $O_2$  carrying capacity of the RBCs is reduced is called Anemia. Depending upon the cause and the symptoms Anemia may be of different types. Before going into the details of anemia let us first discuss some basics.

### 2.1 Basics to Understand Anemia: Blood

Blood is a circulating tissue composed of fluid plasma and cells (red blood cells, white blood cells, platelets). Medical terms related to blood often begin in *hemo-* or *hemato-* from the Greek word "*haima*" for "blood" [28]. Therefore, *hemophobia* is characterized by the abnormal fear of blood [30].

The main function of blood is to supply nutrients (oxygen, glucose) and constitutional elements to tissues and to remove waste products (such as carbon dioxide and lactic acid). Blood also enables cells (leukocytes, abnormal tumor cells) and different substances (amino acids, lipids, hormones) to be transported between tissues and organs. Problems with blood composition or circulation can lead to downstream tissue dysfunction [28]. The blood is circulated around the lungs and body by the pumping action of the heart.

## 2.1.1 Anatomy of Blood

Blood is composed of several kinds of corpuscles; these *formed elements* of the blood constitute about 40% of whole blood [33]. The other 60% [33] is blood plasma, a fluid that is the blood's liquid medium, appearing yellow in color. The normal pH of human arterial blood is approximately 7.40 [33] (normal range is 7.35-7.45). Blood that has a pH below 7.35 is acidic, while blood pH above 7.45 is alkaline [22]. Blood pH along with arterial carbon dioxide tension (PaCO<sub>2</sub>) and HCO<sub>3</sub> readings are helpful in determining the acid-base balance of the body. Blood is about 7% of the human body weight [29], so the average adult has a blood volume of about 5 liters, of which 2.7-3 liters is plasma [22, 23, 24]. The combined surface area of all the erythrocytes in the human anatomy would be roughly 2,000 times as great as the body's exterior surface [7, 30].

The various parts of blood are as follows:

### 2.1.1.1 Blood Corpuscles:

- **Red blood cells or erythrocytes (96%)** [23, 24]: In mammals, mature red blood cells are bi-convex and lack a nucleus and organelles. They contain the blood's hemoglobin and distribute oxygen. The red blood cells (together with endothelial vessel cells and some other cells) are also marked by proteins that define different blood types.
- **White blood cells or leukocytes (3.0%)** [23, 24]: These are part of the immune system; they destroy infectious agents. They are of different types: Neutrophils, Basophils, Eosinophils, Lymphocyte and Monocyte.
- **Platelets or thrombocytes (1.0%)** [23, 24]: These are responsible for blood clotting (coagulation)

### 2.1.1.2 Blood Plasma

It is essentially an aqueous solution containing 96% water, 4% blood plasma proteins [23, 24] , and trace amounts of other materials [23, 24]. Some components are:

- Albumin
- blood clotting factors
- immunoglobulins (antibodies) [25]
- hormones

- various other proteins
- various electrolytes (mainly sodium and chlorine)

Together, plasma and corpuscles form a non-Newtonian fluid whose flow properties are uniquely adapted to the architecture of the blood vessels.

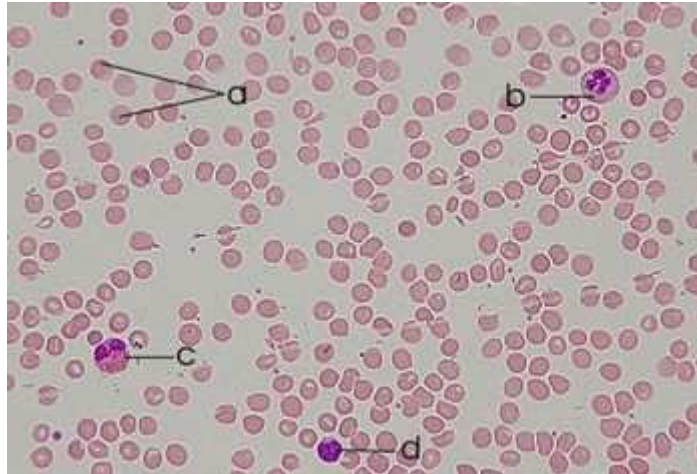

**Figure 2.1: Human blood smear**

a - erythrocytes; b - neutrophil; c - eosinophil; d - lymphocyte.

## 2.1.2 Physiology of Blood

The physiology of the blood is given by following five points:

### 2.1.2.1 Production and Degradation

Blood cells are produced in the bone marrow; the process is termed hematopoiesis [30]. The proteinaceous component is produced overwhelmingly in the liver, while hormones are produced by the endocrine glands and the watery fraction maintained by the gut and the kidney.

Blood cells are degraded by the spleen and the Kupffer cells in the liver [22, 23 24]. The liver also clears proteins and amino acids. The kidney secretes many small proteins into the urine. Erythrocytes usually live up to 120 days before they are systematically replaced by new erythrocytes created by the process of hematopoiesis.

### 2.1.2.2 Transport of Oxygen

Blood oxygenation is measured in several ways, but the most important measure is the hemoglobin saturation percentage. This is a non-linear (sigmoidal) function of the partial pressure of oxygen

[33]. About 98.5% [22, 26] of the oxygen in a sample of arterial blood in a healthy human breathing air at normal pressure is chemically combined with the Hb. Only 1.5% is physically dissolved in the other blood liquids and not connected to Hb [23, 24]. The hemoglobin molecule is the primary transporter of oxygen in mammals and many other species.

Differences in infrared absorption between oxygenated and deoxygenated blood form the basis for real time oxygen saturation measurement in hospitals and ambulances [5]. Under normal conditions in humans, hemoglobin in blood leaving the lungs is about 96-97% saturated with oxygen; 'deoxygenated' blood returning to the lungs is still approximately 75% saturated [11]. A fetus, receiving oxygen via the placenta, is exposed to much lower oxygen pressures (about 20% of the level found in an adult's lungs) and so fetuses produce another form of hemoglobin with a much higher affinity for oxygen (hemoglobin F) in order to extract as much oxygen as possible from this sparse supply [33].

### **2.1.2.3 Transport of Carbon Dioxide**

When systemic arterial blood flows through capillaries, carbon dioxide diffuses from the tissues into the blood. Some carbon dioxide is dissolved in the blood. Some carbon dioxide reacts with hemoglobin to form carbaminohemoglobin. The remaining carbon dioxide is converted to bicarbonate and hydrogen ions. Most carbon dioxide is transported through the blood in the form of bicarbonate ions.

### **2.1.2.4 Transport of Hydrogen Ions**

Some oxyhemoglobin loses oxygen and becomes deoxyhemoglobin. Deoxyhemoglobin has a much greater affinity for  $H^+$  than does oxyhemoglobin so it binds most of the hydrogen ions [33].

### **2.1.2.5 Colour**

In humans and other hemoglobin-using creatures, oxygenated blood is a bright red in its color. Deoxygenated blood is a darker shade of red, which can be seen during blood donation and when venous blood samples are taken. However, due to an optical effect caused by the way in which light penetrates through the skin, veins typically appear blue in color [16]. This has led to a common misconception that before venous blood is exposed to air it is blue [16].

## 2.2 Types of Anemia

**Anemia** or **anaemia**, which literally means "without blood" [31], is a deficiency of red blood cells and/or hemoglobin. This results in a reduced ability of blood to transfer oxygen to the tissues, and this causes hypoxia; since all human cells depend on oxygen for survival, varying degrees of anemia can have a wide range of clinical consequences. Hemoglobin has to be present to ensure adequate oxygenation of all body tissues and organs.

In physiologic terms, therefore anemia may be defined as a reduction in the oxygen transport capability of the blood [22]. Since in most instances the reduced oxygen carrying capacity of blood results from a deficiency of red cells, anemia may be defined as the reduction below normal limits of total circulating red blood mass. This value is not easily measured, however, and therefore anemia may be defined as the reduction below normal in the volume of packed red cells, as measured by the hematocrit, or the reduction in the hemoglobin concentration of the blood. The fluid retention may expand plasma volume, creating spurious abnormalities in clinical measured values. Because anemia is a hematologic (blood-related) condition, a simple blood test called a complete blood count (CBC) is standard and crucial to diagnosis. It measures the level, or counts, of the different types of cells in the blood, including white blood cells (which fight infection) and platelets.

Innumerable classifications of anemia have been proposed based on the morphology of RBCs, underlying etiologic mechanisms, discernible clinical spectra, to mention a few [17].

In the morphological approach, anemia is classified by the size of red blood cells; this is either done automatically or on microscopic examination of a peripheral blood smear. The size is reflected in the *mean corpuscular volume* (MCV). If the cells are smaller than normal (under 80 fl femto litre), the anemia is said to be *microcytic*; if they are normal size (80-100 fl), *normocytic*; and if they are larger than normal (over 100 fl), the anemia is classified as *macrocytic* [30]. This scheme quickly exposes some of the most common causes of anemia; for instance, a microcytic anemia is often the result of iron deficiency [10].

A highly acceptable classification, based on the underlying mechanisms [22], is presented in Table 2.1.

<b>I. ANEMIA DUE TO BLOOD LOSS</b>
<b>A</b> Acute: Trauma
<b>B</b> Chronic: Lesions of GI track, gynecologic distribution
<b>II. INCREASED RATE OF DESTRUCTION (HEMOLYTIC ANEMIA)</b>
<b>A</b> Intrinsic (intracorpuscular) abnormalities of red cells
<b>A1</b> Hereditary
<b>A1.1</b> Red cell membrane disorders <b>A1.1.1</b> Disorders of membrane cytoskeleton: Spherocytosis, elliptocytosis <b>A1.1.2</b> Disorder of lipid synthesis: Selective increase in membrane lecithin
<b>A1.2</b> Red cell enzyme deficiencies <b>A1.2.1</b> Glycolytic enzyme: Pyruvate kinase deficiency, hexokinase deficiency <b>A1.2.2</b> Enzymes of hexose monophosphate shunt: G6PD, glutathione synthetase
<b>A1.3</b> Disorder of hemoglobin synthesis <b>A1.3.1</b> Deficient globin synthesis: Thalassemia syndromes <b>A1.3.2</b> Structurally abnormal globin synthesis (hemoglobinopathies): Sickle cell anemia, unstable hemoglobins
<b>A2</b> Acquired
<b>A2.1</b> Membrane defect: Paroxysmal nocturnal hemoglobinuria
<b>B</b> Extrinsic (extracorpuscular) abnormalities
<b>B1</b> Antibody-mediated.
<b>B1.1</b> Isohemagglutinins: Transfusion reactions, erythroblastosis fetalis <b>B1.2</b> Autoantibodies: Idiopathic (primary), drug-associated, SLE, malignancies, mycoplasma infection

<p><b>B2</b> Mechanical trauma to red cells</p> <p><b>B2.1</b> Microangiopathic hemolytic anemias: Thrombotic thrombocytopenic purpura, DIC</p> <p><b>B2.2</b> Cardiac traumatic hemolytic anemia</p>
<p><b>B3</b> Infections: Malaria</p>
<p><b>B4</b> Chemical injury: Lead poisoning</p>
<p><b>B5</b> Sequestration in mononuclear phagocyte system: Hypersplenism</p>
<p><b>III. IMPAIRED RED CELL PRODUCTION</b></p>
<p><b>A</b> Disturbance of proliferation and differentiation of stem cells: Aplastic anemia, pure red cell aplasia, anemia of renal failure, anemia of endocrine disorders</p>
<p><b>B</b> Disturbance of proliferation and maturation of erythroblasts</p>
<p><b>B1</b> Defective DNA synthesis: deficiency or impaired utilization of vitamin B<sub>12</sub> and folic acid (megaloblastic anemias)</p>
<p><b>B2</b> Defective hemoglobin synthesis</p> <p><b>B2.1</b> Deficient heme synthesis: Iron deficiency</p> <p><b>B2.2</b> Deficient globin synthesis: Thalassemias</p>
<p><b>B3</b> Unknown or multiple mechanisms: Sideroblastic anemia, anemia of chronic infections, myelophthisic due to marrow infiltrations</p>

**Table 2.1: Types of Anemia**

## **2.2.1 Anemias of Blood Loss**

The different types of anemias are explained below:

### **2.2.1.1 Acute Blood Loss**

The clinical and morphologic reactions to blood loss depend on the rate of hemorrhage and whether the blood is lost externally or internally. With acute blood loss, the alternations reflect principally the loss of blood volume rather than the loss of hemoglobin. Shock and death may follow. If the patient survives, the blood volume is rapidly restored by shift of water from the interstitial fluid compartment. The resulting hemodilution lowers the hematocrit. Reduction in the oxygen tension of tissues triggers the production of erythropoietin, and the marrow responds by producing more RBCs. When the blood is lost internally, as into the peritoneal cavity, the iron can

be recaptured, but if the blood is lost externally, the adequacy of the red cell recovery may be hampered by iron deficiency when insufficient reserves are present.

Soon after the acute blood loss the red blood cells appear normal in size and color (normocytic, normochromic). However, as the marrow begins to regenerate, changes occur in the peripheral blood. Most striking is an increase in the Reticulocyte count, reaching 10-15% after 7 days [22]. The reticulocytes are seen as polychromatophilic macrocytes in the usual blood smear. These changes of red cell regeneration can some time be mistaken for an underlying hemolytic process. Mobilization of platelets and granulocytes from the marginal pools leads to thrombocytosis and leukocytosis in the period immediately following acute blood loss.

### **2.2.1.2 Chronic Blood Loss**

Chronic blood loss induces anemia only when the rate of loss exceeds the regenerative capacity of the erythroid precursors or when iron reserves are depleted. In addition to chronic blood loss, any cause of iron deficiency such as malnutrition, malabsorption states, or an increased demand above the daily intake as occurs in pregnancy will lead to an identical anemia [16].

## **2.2.2 Hemolytic Anemias**

The hemolytic anemias all are characterized by [22]:

1. Shortening of normal red cell life span, that is, premature distribution of red cells.
2. Accumulation of the products of hemoglobin catabolism.
3. A marked increase in erythropoiesis within the bone marrow, in an attempt to compensate for the loss of red cells.

The physiologic destruction of senescent red cells takes place in the spleen. In hemolytic anemias, too, the premature destruction of red cells occurs predominantly within the mononuclear phagocyte system (extravascular hemolysis).

Since the number of RBCs are decreased, the anemia and lowered oxygen tension of the tissues, stimulate the increased production of erythropoietin, leading to marked increase in the number of normoblasts in the bone marrow. Also the accelerated production leads to prominent reticulocytosis in the peripheral blood. Figure 2.2.(a) clearly shows hypercellularity of the bone marrow due to proliferation of the normoblasts. This is seen more clearly in Figure 2.2 (b)

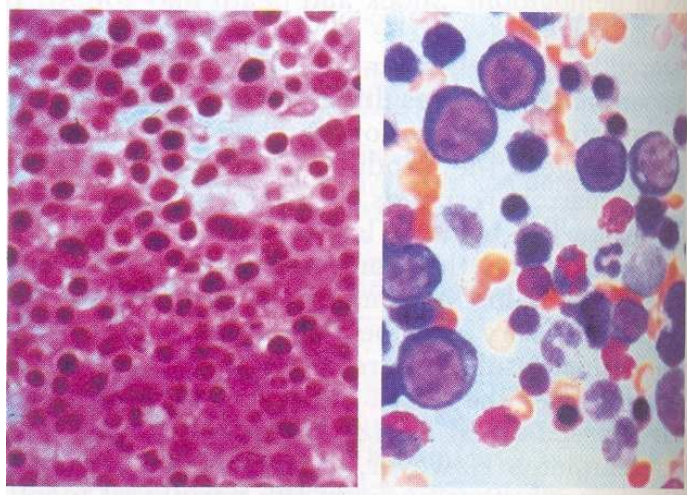

**a) Bone Marrow      b) Smear from a patient**

**Figure 2.2: Hemolytic Anemia**

Hemolysis may either in the blood vessels (intravascular) or outside them (extravascular). So it is of two types:

### **2.2.2.1 Intravascular Hemolysis**

It occurs when normal erythrocytes are damaged by mechanical injury, complement fixation to red cells, or exogenous toxic factors. Trauma to red cells may be caused by mechanical cardiac valves or by thrombi within the microcirculation. Complement fixation may occur on antibody-coated cells during transfusion of mismatched blood. Toxic injury exemplified by falciparum malaria and clostridial sepsis [22]. Whatever the mechanism, intravascular hemolysis is manifested by:

- Hemoglobinemia: abnormal presence of hemoglobin in blood plasma
- Hemoglobinuria: the presence hemoglobin, that has been freed from red blood cells, in the urine
- Methemalbuminemia: methemalbumin in blood
- Jaundice.
- Hemosiderinuria: hemosiderin in blood

When hemoglobin escapes into the plasma, it is promptly bound by an  $\alpha_2$  globulin (haptoglobin) to produce a complex that prevents excretion into the urine, since the complexes are rapidly cleared by the reticuloendothelial system. A decrease in serum haptoglobin level is characteristically seen in all cases of intravascular hemolysis. When the haptoglobin is depleted,

the unbound or free hemoglobin is in part rapidly oxidized to methemoglobin, and both hemoglobin and methemoglobin are excreted through the kidneys, imparting a red-brown to the urine [2].

### **2.2.2.2 Extravascular Hemolysis**

It takes place when red cells:

- are injured
- are rendered foreign
- become less deformable

Extreme alterations are required by the red cells to navigate the splenic sinusoids successfully, reduced deformability makes the passage difficult and leads to sequestration within the cords, followed by phagocytosis. This is believed to be an important pathogenic mechanism of extravascular hemolysis in a variety of hemolytic anemias. With this hemolysis, processes like hemoglobinemia, hemoglobinuria and the related intravascular changes do not occur [22]. However, the catabolism of erythrocytes in the phagocytic cells induce anemia and jaundice as in intravascular hemolysis. Since some hemoglobin is able to escape the phagocytic cells, the plasma haptoglobin levels are invariably reduced. The morphological changes that follow are identical to those in intravascular hemolysis, except that the erythrophagocytosis generally causes hypertrophy of the mononuclear phagocytic cells, and this may lead to splenomegaly. Also the phagocytosed red cells or hemoglobin eventually leads to hemosiderosis of the mononuclear phagocytic system. With this background, it is very easy to understand the hemolytic disorders. The various disorders occur either due to intravascular or extravascular hemolysis.

### **2.2.2.3 Intrinsic (Intracorpuseular) Abnormalities of Red Cells**

#### **2.2.2.3.1 Hereditary**

##### **2.2.2.3.1.1 Red Cell Membrane Disorders**

In this type of anemia, the surface of the RBCs is changed such that it loses its elasticity and cannot navigate the splenic sinusoids successfully, leading to extravascular hemolysis.

### **2.2.2.3.1.1.1 Disorders of Membrane Cytoskeleton**

In this type of anemia, the shape of RBCs becomes spherical, as in case of Spherocytosis (Figure 2.3), or elliptic, as in case of elliptocytosis, leading to its sequestration and phagocytosis.



**Figure 2.3: Smear from a patient with Spherocytosis**

### **2.2.2.3.1.1.2 Disorder of Lipid Synthesis**

In this type of anemia, the lipids in the cell membrane dysfunction causing the surface of RBCs to lose elasticity and hence suffer sequestration and phagocytosis.

### **2.2.2.3.1.2 Red Cell Enzyme Deficiencies**

The RBCs are vulnerable to injury by exogenous or endogenous oxidants. The abnormalities in required enzymes in the shunt chains, which provide energy to the RBCs, can increase the vulnerability. Depending upon the type of enzyme or shunt malfunctioning it's of following types [22]:

- a. Glycolytic enzyme: Pyruvate kinase deficiency, hexokinase deficiency.
- b. Enzymes of hexose monophosphate shunt: G6PD (Figure 2.4), glutathione synthetase.

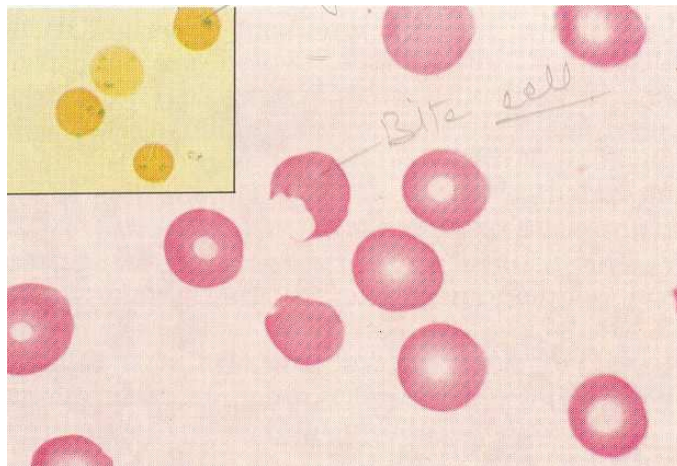

**Figure 2.4: Peripheral blood smear from a patient with G6DP deficiency following exposure to oxidant drug.**

#### **2.2.2.3.1.3 Disorder of Hemoglobin Synthesis**

In this type of anemia, hemoglobin may not be properly formed due to either a defect in heme (iron part of hemoglobin) or globin (protein part of hemoglobin). Hence it is of two types:

##### **2.2.2.3.1.3.1 Deficient Globin Synthesis**

This is mainly due to iron deficiency anemia [13]. Iron deficiency anemia is explained detail in impaired red cell production in Section 2.2.3.2.2.2.

##### **2.2.2.3.1.3.2 Structurally Abnormal Globin Synthesis (Hemoglobinopathies)**

Hemoglobin in adults is mainly HbA with  $2\alpha$  and  $2\beta$  chains in the protein molecule but a point mutation leads to substitution of valine for glutamic acid at the 6<sup>th</sup> position of beta-globin chain [22]. This leads to formation of a sickle shaped RBC (Figure 2.5) which cannot navigate through splenic sinusoids and hence suffer sequestration and phagocytosis.

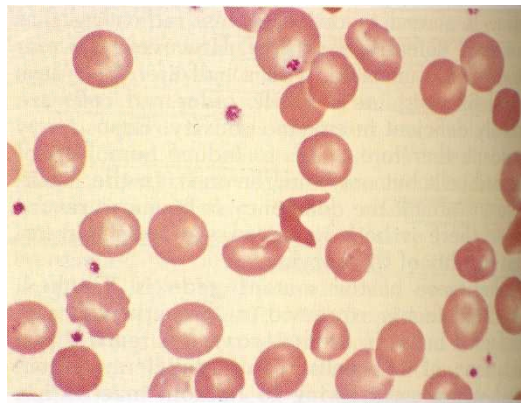

**Figure 2.5: Sickle shaped RBCs in peripheral blood smear of a patient [9]**

### **2.2.2.3.2 Acquired**

#### **2.2.2.3.2.1 Membrane Defect**

This is sudden presence of hemoglobin in urine of a patient at night indicating hemolysis. The causes are not yet clearly understood [3].

### **2.2.2.4 Extrinsic (Extracorporeal) Abnormalities**

These are caused by external agents. The RBCs are destroyed and hemoglobin released. Depending upon the agent they are of following types:

#### **2.2.2.4.1 Antibody-Mediated**

##### **2.2.2.4.1.1 Isohemagglutinins**

Isohemagglutinins agglutinin is capable of causing RBCs to agglutinate (clump together and settle down) when blood of one member of a species is administered to another member of the same species.

##### **2.2.2.4.1.2 Autoantibodies**

Autoantibodies are antibodies that reacts against normal substances present in the host organism

#### **2.2.2.4.2 Mechanical Trauma to Red Cells**

##### **2.2.2.4.2.1 Microangiopathic Hemolytic Anemias**

Microangiopathy is Injury to RBCs occur in the small blood vessels that lead to their destruction. This is caused due to narrowing and obstruction in the microvessels e.g. .capillaries, arterioles and venules. Figure 2.6 shows RBCs of a person suffering from Microangiopathic Hemolytic Anemia.

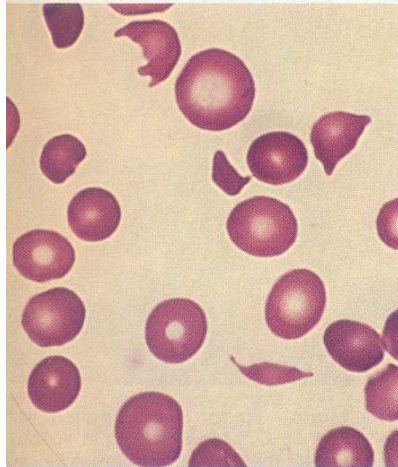

**Figure 2.6: RBCs in blood smear of a patient with Microangiopathic Hemolytic Anemia**

##### **2.2.2.4.2.2 Cardiac Traumatic Hemolytic Anemia**

Injury to RBCs occur while passage of blood through heart.

##### **2.2.2.4.2.3 Infections**

The malarial parasite develops in the RBC thereby weakening and destroying it.

##### **2.2.2.4.2.4 Chemical Injury**

Chemical injuries like lead poisoning also cause anemia.

##### **2.2.2.4.2.5 Sequestration in Mononuclear Phagocyte System**

This is the basis of extravascular hemolysis as explained in section 2.2.2.2 above.

### 2.2.3 Impaired Red Cell Production

Diminished erythropoiesis may result from a deficiency of some vital substance necessary for a red cell formation. Included in this group are iron deficiency anemias, in which heme synthesis is impaired, and anemia of vitamin B<sub>12</sub> and folate deficiency, characterized by defective DNA synthesis. The other cause may be complete failure of erythropoiesis by bone marrow. This leads to conditions like aplastic anemia, pure red cell aplasia and anemia of renal failure. The cause of megaloblastic anemia is primarily a failure of DNA synthesis with preserved RNA synthesis, which result in restricted cell division of the progenitor cells. The megaloblastic anemias often present with neutrophil hypersegmentation (6-10 lobes) [22] as shown in Figure 2.7. The non-megaloblastic macrocytic anemias have different etiologies (i.e. there is unimpaired DNA synthesis,) which occur, for example in alcoholism [2].

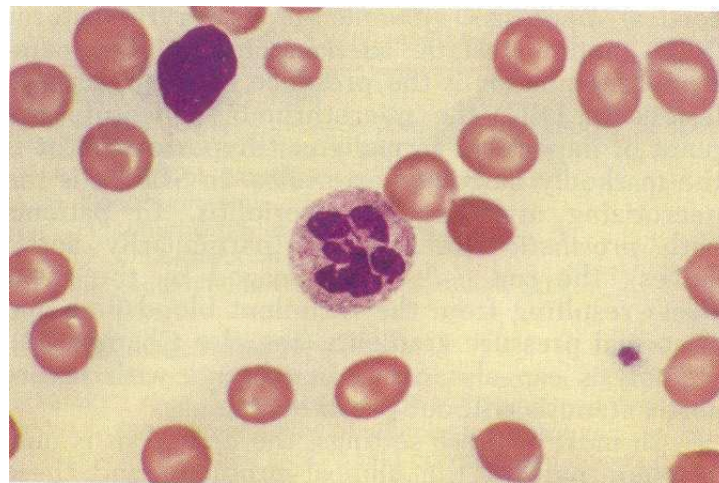

**Figure 2.7: Peripheral blood smear of a patient suffering from Megaloblastic Anemia**

#### 2.2.3.1 Disturbance of Proliferation and Differentiation of Stem Cells

##### 2.2.3.1.1 Aplastic Anemia

Aplastic anemia is rare but it is extremely serious [22,28], the result of unexplained failure of the bone marrow to produce blood cells. It is characterized by low levels of red blood cells, which carry oxygen; white blood cells, which fight infection; and platelets, which prevent bleeding. These low levels are the results of the bone marrows failure to produce enough stem cells, the basic “mother cells “ that give rise to all three blood-cell type---- red cells, white cells and

platelets. It can be triggered by factors that destroy stem cells directly or the drastically change the internal environment of the bone marrow. These factors include exposure to radiation (radiation sickness), chemotherapy, environmental toxins (insecticides, benzene, nitrogen mustards) and many different types of medications, including chloramphenicol (Choloromycetin), phenylbutazone (Butazolidin), sulfonamides (Gantanol and others) and others. Certain viral infections, including hepatitis A, B, C and G; parvovirus B19; human immunodeficiency virus (HIV); and infectious mononucleosis (Epstein-Barr viral infection), also may trigger aplastic anemia [17]. Some people have a genetic predisposition to developing aplastic anemia, especially patients with Fanconi's anemia, an inherited condition characterized by congenital aplastic anemia and physical abnormalities. Pregnancy also increases the risk for mild forms of aplastic anemia that tend to disappear after delivery. In 50 % to 65% of patients with aplastic anemia, the cause of the illness is not clear [17].

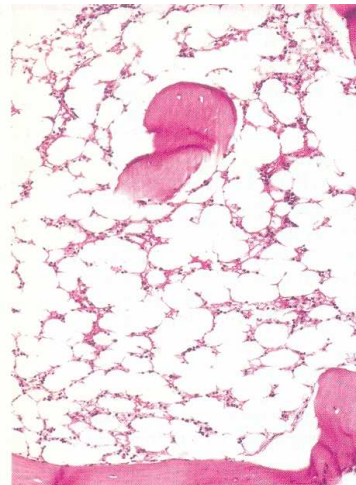

**Figure 2.8: Bone Marrow of a person suffering from Aplastic Anemia.**

#### **2.2.3.1.2 Pure Red Cell Aplasia**

It is a kind of aplastic anemia in which only RBCs are not produced. WBCs and platelets are produced as normal.

## **2.2.3.2 Disturbance of Proliferation and Maturation of Erythroblasts**

### **2.2.3.2.1 Defective DNA Synthesis**

#### **2.2.3.2.1.1 Folic Acid (Folate) Deficiency**

Folic acid—one of the B-complex vitamin—is critical for the body’s metabolism of amino acids, as well as to the formation of healthy red blood cells. In folic acid deficiency, the RBCs produced are usually large, has less hemoglobin and have a shorten life span. Folic acid is a water-soluble vitamin and thus can’t be stored in any great quantity in the body. Therefore it must be replenished by diet on regular basis; the body will exhaust its supply of folate in about three months if the diet is deficient. Folic-acid deficiency may occur among older people who have a poor diet [2, 3]. It also is particularly common among heavy alcohol drinkers, since alcohol interferes with folate absorption. There also is an increased demand of folate during pregnancy , and in the medical condition that cause rapid RBC destruction, such as sickle cell anemia and certain cancers. In these cases, folate supplements usually are prescribed. In addition, adequate folic acid intake is necessary for women who may become pregnant to help prevent birth defects [16].

Folate is found in liver, fortified cereals, lentils, beans, green leafy vegetables, orange juice, and in products made from folate-fortified flour [12, 15].

#### **2.2.3.2.1.2 Vitamin B<sub>12</sub> Deficiency**

Vitamin B<sub>12</sub> deficiency, like folic deficiency, cause anemia—usually large RBCs are produced with the shorten life span. Many older people have B<sub>12</sub> levels that are below the optimal range [2, 3]. This usually is due to an inability to absorb vitamin B<sub>12</sub>, rather than a dietary deficiency, although strict vegetarians are at risk, because vitamin B<sub>12</sub> is found only in animal products. Another common cause of vitamin B<sub>12</sub> deficiency is pernicious anemia, an autoimmune disease in which the immune system attack stomach cells, decreasing the amount of a protein called intrinsic factor. This protein is essential to the absorption of vitamin B<sub>12</sub> from food. Vitamin B<sub>12</sub> deficiency also can develop as a complication of gastrointestinal surgery and certain diseases of the intestine, preventing adequate absorption.

Good source of vitamin B<sub>12</sub> include liver, tuna, cottage cheese, yogurt and eggs [12, 15]. Most standard multivitamin supplements also provide the recommended daily allowance of vitamin B<sub>12</sub>.

Vitamin B<sub>12</sub> deficiency is defined by low level of stored B<sub>12</sub> in the body that can result in anemia

(reduce red blood cell count). Vitamin B<sub>12</sub>, available only in animal food (meat and dairy products) or yeast extracts (such as brewer's yeast), is needed to produce an adequate amount of healthy red blood cells in the bone marrow.

In the long term, low levels of B<sub>12</sub> also can lead to irreversible nerve-cell damage, producing the following symptoms: numbness and tingling in the hands and feet, difficulty walking, muscle weakness, irritability, memory loss, dementia, depression and psychosis [8].

### **2.2.3.2.2 Defective Hemoglobin Synthesis**

#### **2.2.3.2.2.1 Deficient Heme Synthesis: Iron Deficiency**

Iron deficiency is the most common cause of anemia. It occurs when the body lacks the necessary supply of iron to produce an adequate amount of hemoglobin [15]. However lack of iron is not only the cause of anemia. Usually, people have blood loss as well, requiring an increased production of RBCs, which in turn requires extra iron. Young women are at particular risk, because of monthly blood loss with menstruation. Up to 10 percent of women in their reproductive years have iron deficiency, and, in about half of these cases, it is severe enough to cause anemia [16]. Pregnant women are at risk, which is why prenatal vitamins containing extra iron are recommended during pregnancy [14, 18]. Iron-deficiency is rare in men and in postmenopausal women. However, low iron levels in this group is a warning that serious abnormal bleeding could be occurring due to undiagnosed medical conditions such as ulcer disease or colon cancer.

The highest amount of iron is found in meat, spinach, raisins, lentils, and enriched flour. Iron is absorbed most efficiently, however, from red meat – which is why pre-menopausal women who don't eat much meat are at particular risk for iron-deficiency anemia. Other factors also contribute to how much iron is absorbed in the body.

Vitamin C enhances the absorption of iron from the intestine. Citrus foods are well known for their vitamin C content, but many vegetables are also a good source of vitamin C, such as tomatoes, cauliflower, broccoli and potatoes [12, 15].

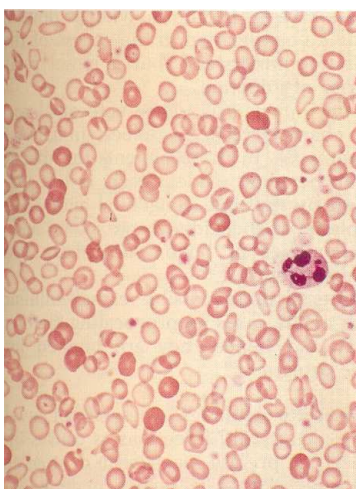

**Figure 2.9: Peripheral blood smear of a patient showing of Iron Deficiency Anemia**

#### **2.2.3.2.2 Deficient Globin Synthesis : Thalassemias**

This is caused by lack or decrease synthesis of either the  $\alpha$  or  $\beta$ - globin chain of hemoglobin A and hence is classified as  $\alpha$ - Thalassemia or  $\beta$ - Thalassemia respectively. This leads to formation of less hemoglobin and hence the Mean Corpuscular Hemoglobin Concentration (MCHC) is low. The cells formed are highly unstable and most of them are destroyed in the bone marrow. Those which manage to escape are destroyed by sequestration and phagocytosis in the spleen.

#### **2.2.3.2.3 Unknown or Multiple Mechanisms**

##### **2.2.3.2.3.1 Anemia Due to Chronic Infections**

It is impaired red cell production associated with chronic diseases. This type of anemia is characterized by defective iron utilization. Low serum iron and decrease in total iron binding capacity in association with abundant stored iron in the mononuclear phagocyte cells is a characteristic of this type of anemia.

##### **2.2.3.2.3.2 Myelophthisic Anemia**

Space occupying lesions in the bone marrow disturb its architecture and depress its productive capacity. This is known as myelophthisic anemia. This causes immature RBCs and WBCs to be released in the peripheral blood.

## Fuzzy logic and LabVIEW

### 3.1 What is Fuzzy Logic?

*“How important is it to be exactly right when a rough answer will do?”*

Fuzzy logic is a convenient way to map an input space to an output space. For example, the user tells the controller how hot he wants the water to be and the controller adjusts the faucet valve to the right setting, the user tells the camera control how far away the subject of photograph is, and the controller adjusts the focus the lens etc. A graphical example of an input-output map is shown in Figure 3.1.

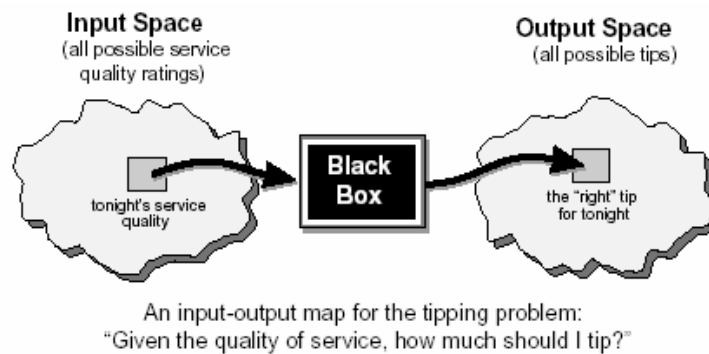

**Figure 3.1: Illustration of Fuzzy Logic**

It's all just a matter of mapping inputs to the appropriate outputs. Between the input and the output there's a black box that does the work. The black box may contain any number of things like fuzzy systems, linear systems, expert systems, neural networks, differential equations, interpolated multidimensional lookup tables, or even a spiritual advisor. Of the dozens of ways to make the black box work, it turns out that fuzzy is often the very best way as Lotfi Zadeh, who is considered to be the father of fuzzy logic, once remarked:

*“In almost every case you can build the same product without fuzzy logic, but fuzzy is faster and cheaper” [32]*

The point of fuzzy logic is to map an input space to an output space, and the primary mechanism

for doing this is a list of if-then statements called rules. All rules are evaluated in parallel, and the order of the rules is unimportant. The rules themselves are useful because they refer to variables and the adjectives that describe those variables. Before we can build a system that interprets rules, we have to define all the terms we plan on using and the adjectives that describe them. If we want to talk about how hot the water is, we need to define the range that the water's temperature can be expected to vary over as well as what we mean by the word hot. Figure 3.2 is like a roadmap for the fuzzy inference process.

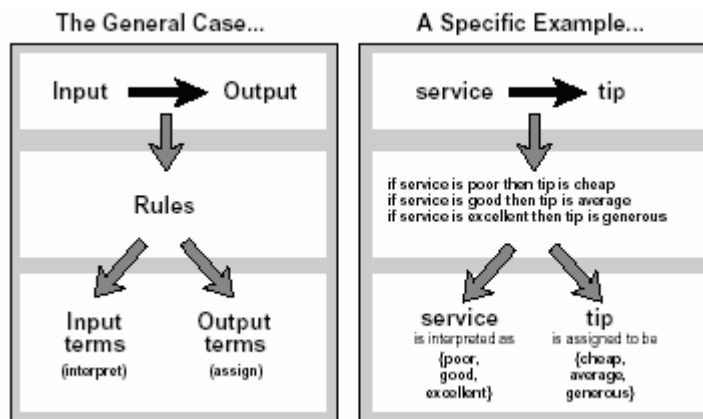

**Figure 3.2: Concept of Fuzzy Inference System**

Fuzzy logic is all about the relative importance of precision: Fuzzy logic is a fascinating area of research because it does a good job of trading off between significance and precision - something that humans have been managing for a very long time [32].

### 3.1.1 Foundations of Fuzzy Logic

*“Everything is vague to a degree you do not realize till you have tried to make it precise”*

#### 3.1.1.1 Fuzzy Sets

A *fuzzy set* is a set without a crisp, clearly defined boundary. It can contain elements with only a partial degree of membership. To understand what a fuzzy set is, first consider what is meant by what we might call a *classical set*. A classical set is a container that wholly includes or wholly excludes any given element. For example, the set of days of the week unquestionably includes Monday, Thursday, and Saturday. It just as unquestionably excludes butter, liberty, and dorsal fins, and so on. We call this set a classical set because it's been around for such a long time. It was

Aristotle who first formulated the Law of the Excluded Middle, which says X must either be in set A or in set not-A. This law demands that opposites, the two categories A and not-A, should between them contain the entire universe. Everything falls into either one group or the other. There is no thing that is both a day of the week and not a day of the week.



**Figure 3.3: Binary Set**

Now consider the set of days comprising a weekend. Figure 3.4 is one attempt at classifying the weekend days.

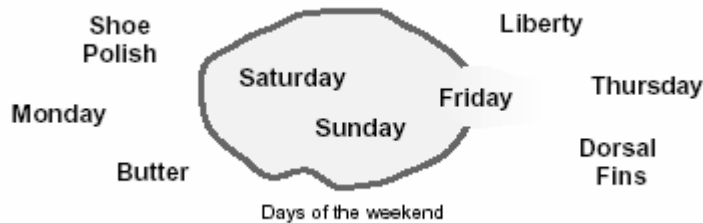

**Figure 3.4: Fuzzy Set**

Most would agree that Saturday and Sunday belong, but what about Friday? It “feels” like a part of the weekend, but somehow it seems like it should be technically excluded. So in the diagram above Friday tries its best to sit on the fence. Classical or “normal” sets wouldn’t tolerate this kind of thing. Either you’re in or you’re out. But as per human experience fence sitting is a part of life. Even the dictionary is imprecise, defining the weekend as “the period from Friday evening to Sunday evening”. We’re entering the realm where sharp edged yes-no logic stops being helpful. Fuzzy reasoning becomes valuable exactly when we’re talking about how people really perceive the concept “weekend” as opposed to a simple-minded classification useful for accounting purposes only. The following statement lays the foundations for fuzzy logic:

*“In fuzzy logic, the truth of any statement becomes a matter of degree”.*

Any statement can be fuzzy. The tool that fuzzy reasoning gives is the ability to reply to a yes-no

question with a not-quite-yes-or-no answer. This is the kind of thing that humans do all the time but it's a rather new trick for computers.

How does it work? Reasoning in fuzzy logic is just a matter of generalizing the familiar yes-no (Boolean) logic. If we give "true" the numerical value of 1 and "false" the numerical value of 0, fuzzy logic also permits in-between values like 0.2 and 0.7453. For instance,

Figure 3.5(a) shows the truth values for "weekend-ness" if we are forced to respond with an absolute yes or no response while Figure 3.5(b) shows the truth value for weekend-ness if we are allowed to respond with fuzzy in-between values.

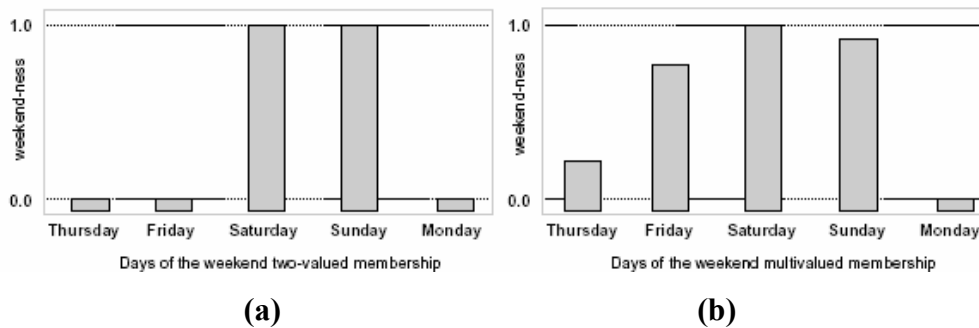

**Figure 3.5: Binary v/s Fuzzy Values**

Technically, the representation in Figure 3.5(b) is from the domain of *multi-valued logic* (or multivalent logic) e.g. If someone asks a question "Is X a member of set A?" the answer might be yes, no, or any one of the numerous intermediate values. In other words, X might have partial membership in A. Multi-valued logic stands in direct contrast to the more familiar concept of two-valued (or bivalent yes-no) logic.

### 3.1.1.2 Membership Functions

A *membership function* (MF) is a curve that defines how each point in the input space is mapped to a membership value (or degree of membership) between 0 and 1. The input space is sometimes referred to as the *universe of discourse*.

A classical set might be expressed as  $A = \{x \mid x > 6\}$ .

A fuzzy set is an extension of a classical set. If X is the universe of discourse and its elements are denoted by  $x$ , then a fuzzy set A in X is defined as a set of ordered pairs.

$$A = \{x, \mu_A(x) \mid x \in X\}$$

Where  $\mu_A(x)$  is called the membership function (or MF) of  $x$  in  $A$ .

To return to our example, we now consider a continuous scale time plot of weekend-ness as shown in Figure 3.6.

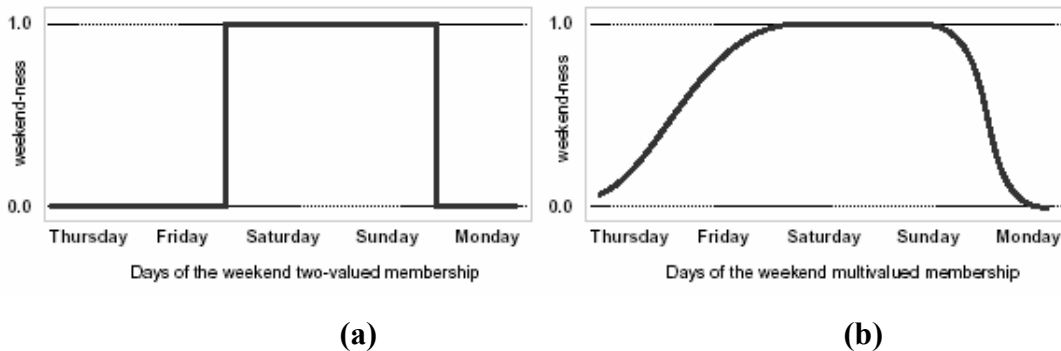

**Figure 3.6: Binary v/s Fuzzy Functions**

By making the plot continuous, we're defining the degree to which any given instant belongs in the weekend rather than an entire day. In Figure 3.6 (a), notice that at midnight on Friday, just as the second hand sweeps past 12, the weekend-ness truth value jumps discontinuously from 0 to 1. This is one way to define the weekend, and while it may be useful to an accountant, it doesn't really connect with our real-world experience of weekend-ness. Figure 3.6 (b) shows a smoothly varying curve that accounts for the fact that all of Friday, and, to a small degree, parts of Thursday, partake of the quality of weekend-ness and thus deserve partial membership in the fuzzy set of weekend moments. Such curve that serves as a function mapping the input space (time of the week) to the output space (weekend-ness) is known as a membership function and is often given the designation of  $m$ .

The only condition a membership function must really satisfy is that it must vary between 0 and 1.

### 3.1.1.3 Logical Operations

Till now we have discussed that what is fuzzy about fuzzy logic, now we will go to the logic. The most important thing to realize about fuzzy logical reasoning is the fact that it is a superset of standard Boolean logic. As an example, consider the standard truth tables shown in Figure 3.7.

A	B	A and B
0	0	0
0	1	0
1	0	0
1	1	1

**AND**

A	B	A or B
0	0	0
0	1	1
1	0	1
1	1	1

**OR**

A	not A
0	1
1	0

**NOT**

**Figure 3.7: Binary Logical Operators**

The input values can be real numbers between 0 and 1. The function that will preserve the results of the AND truth table (for example) and also extend to all real numbers between 0 and 1 is the *min* operation. Using the same reasoning, we can replace the OR operation with the *max* function, so that  $A \text{ OR } B$  becomes equivalent to  $\max(A,B)$ . Finally, the operation NOT  $A$  becomes equivalent to the operation. The truth table above is completely unchanged by this substitution as shown in Fig 3.8.

A	B	$\min(A,B)$
0	0	0
0	1	0
1	0	0
1	1	1

**AND**

A	B	$\max(A,B)$
0	0	0
0	1	1
1	0	1
1	1	1

**OR**

A	$1 - A$
0	1
1	0

**NOT**

**Figure 3.8: Fuzzy Logical Operators**

Moreover, since there is a function behind the truth table rather than just the truth table itself, we can now consider values other than 1 and 0.

#### 3.1.1.4 If-Then Rules

Fuzzy sets and fuzzy operators are the subjects and verbs of fuzzy logic. These if-then rule statements are used to formulate the conditional statements that comprise fuzzy logic. A single fuzzy if-then rule assumes the form:

$$\text{if } x \text{ is } A \text{ then } y \text{ is } B$$

where  $A$  and  $B$  are linguistic values defined by fuzzy sets on the ranges (universes of discourse)  $X$  and  $Y$ , respectively. The if-part of the rule “ $x$  is  $A$ ” is called the *antecedent* or premise, while the then-part of the rule “ $y$  is  $B$ ” is called the *consequent* or conclusion. An example of such a rule might be

*if service is good then tip is average*

*good* is represented as a number between 0 and 1, and so the antecedent is an interpretation that returns a single number between 0 and 1. On the other hand, *average* is represented as a fuzzy set, and so the consequent is an assignment that assigns the entire fuzzy set  $B$  to the output variable  $y$ . In general, the input to an if-then rule is the current value for the input variable (in this case, *service*) and the output is an entire fuzzy set (in this case, *average*). This set will later be *defuzzified*, assigning one value to the output.

Interpreting if-then rules is a three-part process:

1. *Fuzzify inputs*: Resolve all fuzzy statements in the antecedent to a degree of membership between 0 and 1. If there is only one part to the antecedent, this is the degree of support for the rule.
2. *Apply fuzzy operator to multiple part antecedents*: If there are multiple parts to the antecedent, apply fuzzy logic operators and resolve the antecedent to a single number between 0 and 1. This is the degree of support for the rule
3. *Apply implication method*: Use the degree of support for the entire rule to shape the output fuzzy set. The consequent of a fuzzy rule assigns an entire fuzzy set to the output. This fuzzy set is represented by a membership function that is chosen to indicate the qualities of the consequent. If the antecedent is only partially true, (i.e., is assigned a value less than 1), then the output fuzzy set is truncated according to the implication method.

### **3.1.1.5 Defuzzification**

Defuzzification is conversion of fuzzy values to crisp values. The various methods used for defuzzification are as under:

#### **3.1.1.5.1 The Max-Min Method**

This method tests the magnitudes of each rule and selects the highest one. The horizontal coordinate of the "fuzzy centroid" of the area under that function is taken as the output. This method does not combine the effects of all applicable rules but does produce a continuous output

function and is easy to implement.

#### **3.1.1.5.2 The Max-Dot or Max-Product Method**

This method scales each member function to fit under its respective peak value and takes the horizontal coordinate of the "fuzzy" centroid of the composite area under the function(s) as the output. Essentially, the member function(s) are shrunk so that their peak equals the magnitude of their respective function ("negative", "zero", and "positive"). This method combines the influence of all active rules and produces a smooth, continuous output.

#### **3.1.1.5.3 The Averaging Method**

It is another approach that is used to calculate the crisp value. For example, if three "negative" rules fire, but only one "zero" rule does, averaging will not reflect this difference since both averages will equal 0.5. Each function is clipped at the average and the "fuzzy" centroid of the composite area is computed.

#### **3.1.1.5.4 The Root-Sum-Square (RSS) Method**

It combines the effects of all applicable rules, scales the functions at their respective magnitudes, and computes the "fuzzy" centroid of the composite area. This method is more complicated mathematically than other methods, but gives the best weighted influence to all firing rules.

#### **3.1.1.6 Fuzzy Inference Systems**

Fuzzy inference is the process of formulating the mapping from a given input to an output using fuzzy logic. The mapping then provides a basis from which decisions can be made, or patterns discerned. Fuzzy inference systems have been successfully applied in fields such as automatic control, data classification, decision analysis, expert systems, and computer vision. Because of its multidisciplinary nature, fuzzy inference systems are associated with a number of names, such as fuzzy-rule-based systems, fuzzy expert systems, fuzzy modeling, fuzzy associative memory, fuzzy logic controllers, and simply fuzzy systems. .

### 3.1.2 Advantages of Fuzzy Logic

1. Fuzzy logic is conceptually easy to understand: The mathematical concepts behind fuzzy reasoning are very simple.
2. Fuzzy logic is flexible: With any given system, it's easy to massage it or layer more functionality on top of it without starting again from scratch.
3. Fuzzy logic is tolerant of imprecise data: Everything is imprecise if we look closely, but most things are imprecise even on careful inspection. Fuzzy reasoning builds this understanding into the process rather than tacking it onto the end.
4. Fuzzy logic can model nonlinear functions of arbitrary complexity: You can create a fuzzy system to match any set of input-output data.
5. Fuzzy logic can be built on top of the experience of experts [21, 32]: In direct contrast to neural networks, which take training data and generate opaque, impenetrable models, fuzzy logic lets you rely on the experience of people who already understand your system.
6. Fuzzy logic can be blended with conventional control techniques: Fuzzy systems don't necessarily replace conventional control methods. In many cases fuzzy systems augment them and simplify their implementation.
7. Fuzzy logic is based on natural language: The basis for fuzzy logic is the basis for human communication. Since fuzzy logic is based on natural language, which is used by ordinary people on a daily basis, so it is easy to use.

### 3.1.3 When Not to Use Fuzzy Logic

Fuzzy logic is a convenient way to map an input space to an output space. If we do not find it convenient we can try something else. If a simpler solution already exists, we can use it. Fuzzy logic is the codification of common sense and we have to use common sense when we implement it. Many controllers, for example, do a fine job without using fuzzy logic. However fuzzy logic can be a very powerful tool for dealing quickly and efficiently with imprecision and nonlinearity [21].

### 3.1.4 Fuzzy Expert Systems

A fuzzy expert system is a collection of membership functions and rules that are used to reason about data. Unlike conventional expert systems, which are mainly symbolic reasoning engines, fuzzy expert systems are oriented toward numerical processing.

General architecture of the expert system is shown in Figure 3.9.

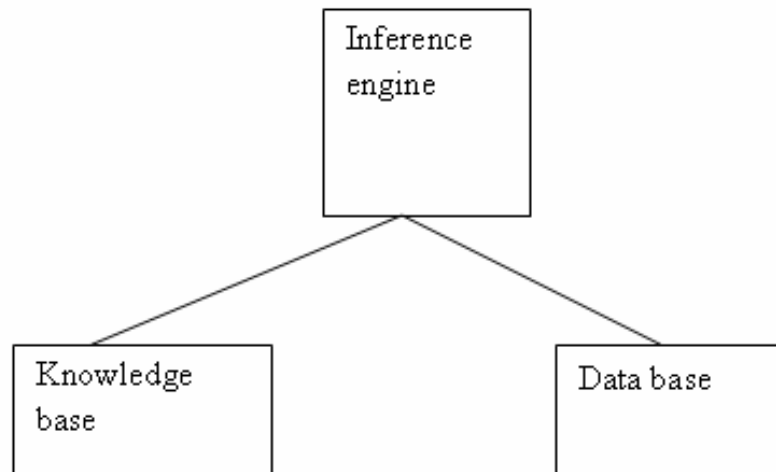

**Figure 3.9: General architecture of a Fuzzy Expert System**

Expert systems are often called rule-based systems, because they are built on a production system architecture and they use rules to express knowledge .the special features of an expert system are:

1. A computer program that solves expert problems by expert knowledge or handles task that require detailed knowledge in a particular area.
2. Expert knowledge is distinct from the common sense knowledge .
3. Operates in a micro-world where a particular kind of problem solving is required.
4. Encapsulates a significant portion of the specialized knowledge that an expert human problem solver would bring to bear.
5. Usually exhibits performance approaching of an expert.

In this project we have made an effort to develop the expert system based on the fuzzy logic concept to detect and diagnose the various types of anemia!

## **3.2 What is LabVIEW?**

**LabVIEW** (**L**aboratory **V**irtual **I**nstrumentation **E**ngineering **W**orkbench) is a platform and development environment for a visual programming language from National Instruments. It is a program development application, much like C or FORTRAN, however, different from those applications in one important respect. Other programming systems use text-based languages to create lines of code, while LabVIEW uses a graphical programming language, G, to create programs in block diagram form.

Originally released for the Apple Macintosh in 1986 [34], LabVIEW is used for data acquisition, instrument control, and industrial automation on a variety of platforms including Microsoft Windows, various flavors of UNIX, Linux, and Mac OS. The latest version of LabVIEW is version 8.0 [30, 34]. LabVIEW language has a tremendous collection of libraries and structures that have been introduced and improved over the past 20 years [30, 34].

### **3.2.1 Features of LabVIEW**

The following are the key elements of the LabVIEW development platform:

#### **3.2.1.1 Point- and Click Approach**

LabVIEW is a development environment based on a graphical programming language. This approach to developing applications significantly reduces the learning curve because graphical representations are a more natural design notation for engineers and scientists than text-based code. We can access the tools and functions through interactive palettes, dialogs, menus, and hundreds of function blocks, known as VIs (virtual instruments). We can drag and drop these VIs onto a diagram to define the behavior of the applications. This point-and-click approach significantly reduces the time it takes to get from initial setup to a final solution.

#### **3.2.1.2 Dataflow**

We define the flow of data and the execution of the application through a concept known as dataflow programming. Data is passed from one VI to the next, eventually defining the execution order and functionality of the entire application. Dataflow is comparable in nature to reading a flow chart. Block diagrams consist of functions, which are represented by icons, wires that connect

these icons, and structures that control execution logic. Data flows from one function to the next, and the functions and VIs do not execute until all terminals or wire connections have data available for processing.

### **3.2.1.3 Modularity**

LabVIEW naturally encourages modularity and reuse of code. Users create VIs, or code modules, with a graphical front panel that displays the inputs and outputs of the functional code as graphical controls and indicators. The graphical controls and indicators (knobs, meters, gauges, graph displays, strip charts, etc) represent data types for the data passing into and out of the functions. Users can easily plug these VIs into other VIs, allowing for modular, hierarchical code that enables users to gradually build up complex systems one component at a time and reuse common operations as SubVIs along the way. There is no limit to the number of layers or SubVIs used in an application, so the language scales with the complexity required for the application.

### **3.2.1.4 Multithreading and Parallelism**

LabVIEW eliminates much of the tedious low-level coding required by traditional languages, such as memory management. LabVIEW also has intuitive graphical structures for common programming structures in text-based languages e.g. while loops and for loops are represented as a box – the code residing graphically within the box is code executed by the loop iterations.

LabVIEW is also designed as a parallel language, which means that the graphical language constructs naturally represent the simple concept of parallel execution. This simple concept, however, can be very difficult to implement in text-based languages because they traditionally execute sequentially (line by line). With LabVIEW, users can develop parallel-executing applications simply by placing multiple loop structures into their code. This feature is an incredibly simple way to represent a very difficult coding challenge. Parallel execution can be critical in automated test systems, where multiple units under test (UUTs) may be tested, in real-time control systems, where time-critical loops are acquiring data and controlling outputs while data is communicated to the host at the same time, or in embedded applications, where multiple types of inputs must be responded to in a deterministic fashion.

### **3.2.1.5 Interactive Execution and Debugging**

The LabVIEW language is interactive as well, which means users can easily experiment with different functions in the libraries during development, which is particularly important when programming I/O resources e.g. when configuring a data acquisition (DAQ) operation, users can simply select an acquisition function from the built-in DAQ library and run it independently. This operation will actually retrieve data from the DAQ board in the computer, so the user can inspect the data to see if the operation is appropriate for the program. If so, simply drop the VI into the program and continue. If not, try another VI in the library until we find the right one. Debugging in LabVIEW is also interactive, featuring all of the common capabilities of traditional programming tools, such as breakpoints, step over/into/out of, and so on. A unique debugging capability of LabVIEW is the ability to visualize data anywhere within the algorithms we develop without degrading the performance of the algorithm or requiring complex programming.

### **3.2.1.6 Multiple Computing Targets**

Another feature of the LabVIEW platform is its open back end that can target a wide variety of computing platforms. The native LabVIEW compiler runs on all popular desktop OSs, such as Windows, Mac OS X, and Linux. LabVIEW also runs on industrial real-time platforms, for applications that require determinism or additional reliability. LabVIEW programs also can be targeted to handheld devices running Windows Mobile, Windows CE, or Palm OS. In addition to the obvious handheld PDA or smart phone devices, these technologies are often found on flat panel displays used in machines or industrial systems. And finally, the LabVIEW embedded family of products converts LabVIEW diagrams into C code for execution on 32-bit microprocessors.

## **3.2.2 Advantages of LabVIEW**

1. Extensive support for accessing instrumentation hardware: This is the major benefit LabVIEW has over other development environments. Drivers and abstraction layers for many different types of instruments and buses are included or available. These present themselves as graphical nodes. The abstraction layers offer standard software interfaces to communicate with hardware devices. The provided driver interfaces save program development time.

2. Easy: Even people with limited coding experience can write programs and deploy test solutions in a reduced time frame when compared to more conventional or competing systems.
3. Platform portable code: In terms of performance, LabVIEW includes a compiler that produces native code for the CPU platform. The graphical code is translated into executable machine code by interpreting the syntax and by compilation. The LabVIEW syntax is strictly enforced during the editing process and compiled into the executable machine code when requested to run or upon saving. In the latter case, the executable and the source code are merged into a single file. The executable runs with the help of the LabVIEW run-time engine, which contains some precompiled code to perform common tasks that are defined by the G language. The run-time engine reduces compile time and also provides a consistent interface to various operating systems, graphic systems, hardware components, etc. The run-time environment makes the code portable across platforms like Windows, MacOSX and Linux. [30, 34].
4. Large collection of libraries: Many libraries with a large number of functions for data acquisition, signal generation, mathematics, statistics, signal conditioning, analysis, etc., along with numerous graphical interface elements are provided in several LabVIEW package options.

With this wide array of computing targets, LabVIEW users can choose the right run-time environment for their application, as well as scale up or down as their requirements change

---

## Software Implementation

### 4.1 Fuzzy Logic System for Anemia Detection

The concept of fuzzy logic is useful for diagnosing anemia as sometimes the laboratory test results does not give anything conclusive. The doctor is stuck between two or three conclusions as to which type of anemia the patient suffers from. The fuzzy logic with the concept of membership function facilitates the diagnosis as it can tell which of the possible options has the highest possibility. The various steps, the implementation of these steps and the associated results are discussed in the following sections.

### 4.2 Fuzzy Subsets

The fuzzy subsets for various input values are as follows:

Crisp Value $\rightarrow$					
Fuzzy Subset $\downarrow$	2	7	12	17	22
very low	0.5	0.25	0	0	0
Low	0	0.75	0	0	0
normal	0	0	1	0	0
high	0	0	0	0.75	0

**4.1 (a) Hemoglobin (HGLN) units: gm/dl**

	Crisp Value →				
Fuzzy Subset ↓	22	26	30	34	39
very low	0.48	0.56	0	0	0
Low	0	0.44	0.6	0	0
normal	0	0	0.4	0.64	0
high	0	0	0	0.36	0.44
very high	0	0	0	0	0.56

**4.1 (b) Hematocrit (HMCT) units: % of blood sample taken**

	Crisp Value →				
Fuzzy Subset ↓	58	68	81	93	108
very low	0.64	0.56	0	0	0
Low	0	0.44	0.52	0	0
normal	0	0	0.48	0.56	0
high	0	0	0	0.44	0.36
very high	0	0	0	0	0.64

**4.1 (c) Mean Corpuscular Volume (MCV) units: cubic microns**

	Crisp Value →				
Fuzzy Subset ↓	22	26	30	34	39
very low	0.48	0.56	0	0	0
Low	0	0.44	0.6	0	0
normal	0	0	0.4	0.64	0
high	0	0	0	0.36	0.44
very high	0	0	0	0	0.56

**4.1 (d) Means Corpuscular Hemoglobin Concentration (MCHC)**

	Crisp Value →				
Fuzzy Subset ↓	1	2	4	5	7
very low	0.6	0.8	0	0	0
low	0	0.2	0.6	0	0
normal	0	0	0.4	1	0
high	0	0	0	0	0.8
very high	0	0	0	0	0.2

**4.1 (e) Reticulocyte Count (RCC) units: % of erythrocytes or 1000 cells/micro L**

	Crisp Value →				
Fuzzy Subset ↓	2111	4125	6541	8958	11777
very low	0.666621	0.5	0	0	0
Low	0	0.5	0.500276	0	0
normal	0	0	0.499724	0.500138	0
high	0	0	0	0.499862	0.333655
very high	0	0	0	0	0.666345

**4.1 (f) White Blood Cells (WBC) units: no /cubic mm (in thousands)**

	Crisp Value →				
Fuzzy Subset ↓	1044	2287	3779	5270	7011
very low	0.666369	0.500335	0	0	0
low	0	0.499665	0.500112	0	0
normal	0	0	0.499888	0.500559	0
high	0	0	0	0.499441	0.333408
very high	0	0	0	0	0.666592

**4.1 (g) Platelets (PLT) units: no /cubic mm (in thousands)**



Crisp Value →					
Fuzzy Subset ↓	44	100	166	233	311
very low	0.66	0.5	0	0	0
Low	0	0.5	0.51	0	0
normal	0	0	0.49	0.505	0
high	0	0	0	0.495	0.335
very high	0	0	0	0	0.665

**4.1 (h) Total Iron Binding Capacity (TIBC) units: microgram**

Crisp Value →					
Fuzzy Subset ↓	36	70	110	150	196
very low	0.65	0.5	0	0	0
Low	0	0.5	0.5	0	0
normal	0	0	0.5	0.5	0
high	0	0	0	0.5	0.35
very high	0	0	0	0	0.65

**4.1 (i) Serum Iron (SEI) units: microgram/dl**

Crisp Value →	3	6	9	12	15
Fuzzy Subset ↓					
Present	0	0.2	0.8	1	1
Not Present	1	0.8	0.2	0	0

**4.1 (j) Nucleated Red Cells (NRC) units: %rbc**

Crisp Value →	3	6	9	12	15
Fuzzy Subset ↓					
Present	0	0.2	0.8	1	1
Not Present	1	0.8	0.2	0	0

**4.1 (k) Hyper Segmented White Cells (HSWC) units: %rbc**

Crisp Value →	3	6	9	12	15
Fuzzy Subset ↓					
Present	0	0.2	0.8	1	1
Not Present	1	0.8	0.2	0	0

#### 4.1 (l) Ringed Sideroblast In Bone Marrow (RSBM) units: %rbc

**Table 4.1 (a-l): Membership values of various Fuzzy Subsets for different inputs**

### 4.3 The 12 Input Fuzzy Control System in LabVIEW

LabVIEW fuzzy logic controller has the disadvantage of having maximum of four inputs and our project included about 12 inputs, so the controller cannot be used. Hence there was a need to design the whole logic right from the scratch.

The details of the inputs involved in this control system are already given in the Section 4.2, while the rule base has been discussed in the appendix section of the report. Here we are presenting with the code or the logic that was used to develop the fuzzy control system having 12 inputs and 18 outputs.

The flowchart for the implementation of the problem is shown in Figure 4.1

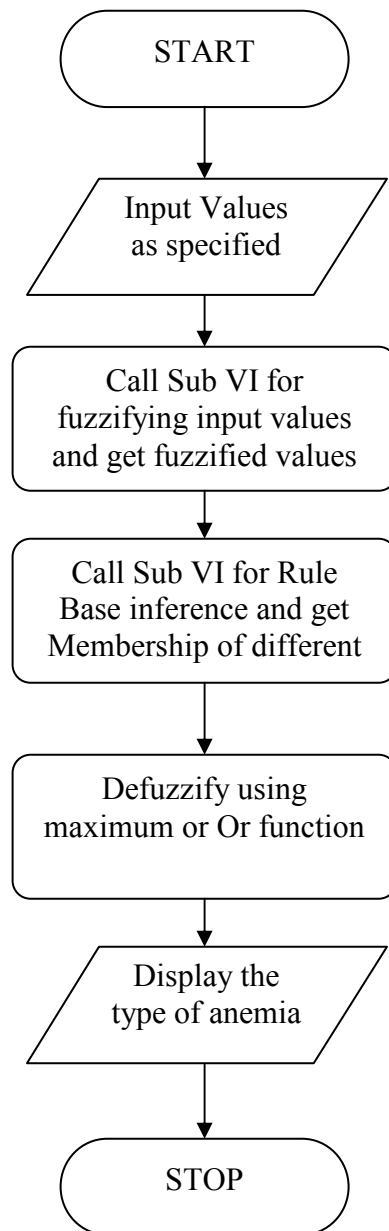

**Fig 4.1: Flowchart for the 12 input Fuzzy Control System in LabVIEW**

The various steps are implemented as follows:

### 4.3.1 Input Values

#### 4.3.1.1 Block Diagram

This sequence (internal) basically deals with work of property nodes helping the user to enter input one at a time and hiding others. On clicking the ok button (Boolean) provided on the front panel the next input variable comes in along with the graphic display of that particular input showing its membership functions.

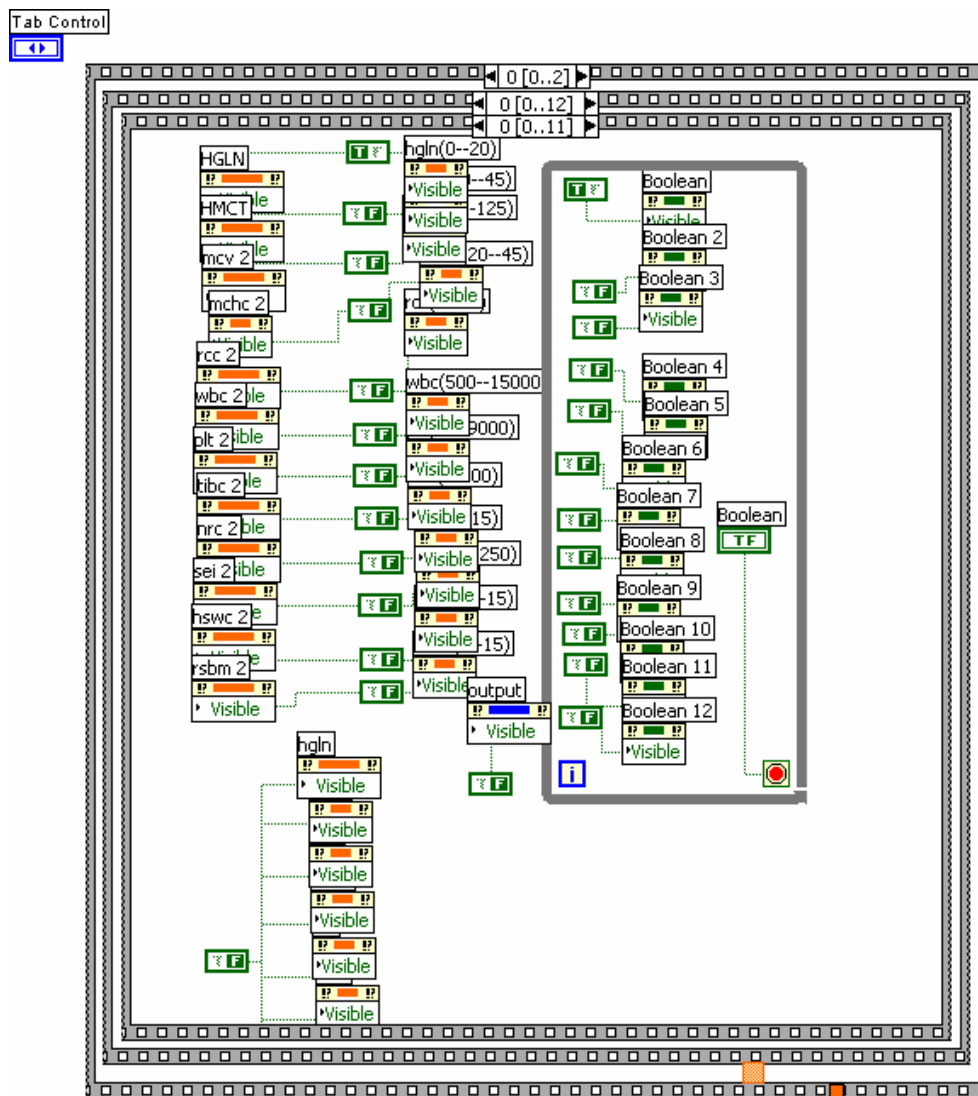

Figure 4.2: Block Diagram for the getting Inputs

### 4.3.2 Fuzzification

The first step for designing the fuzzy logic controller was to fuzzify the inputs, for this we have to develop the fuzzy sets and the membership functions of each input. This diagram fuzzifies the input data using SubVI Fuzzifier explained in Section 4.4.1. It takes the input value, number of membership functions, and range of input (lower and upper limit) and gives fuzzified outputs (max=5). The outputs to be used in next sequences have been made global to avoid excessive wiring.

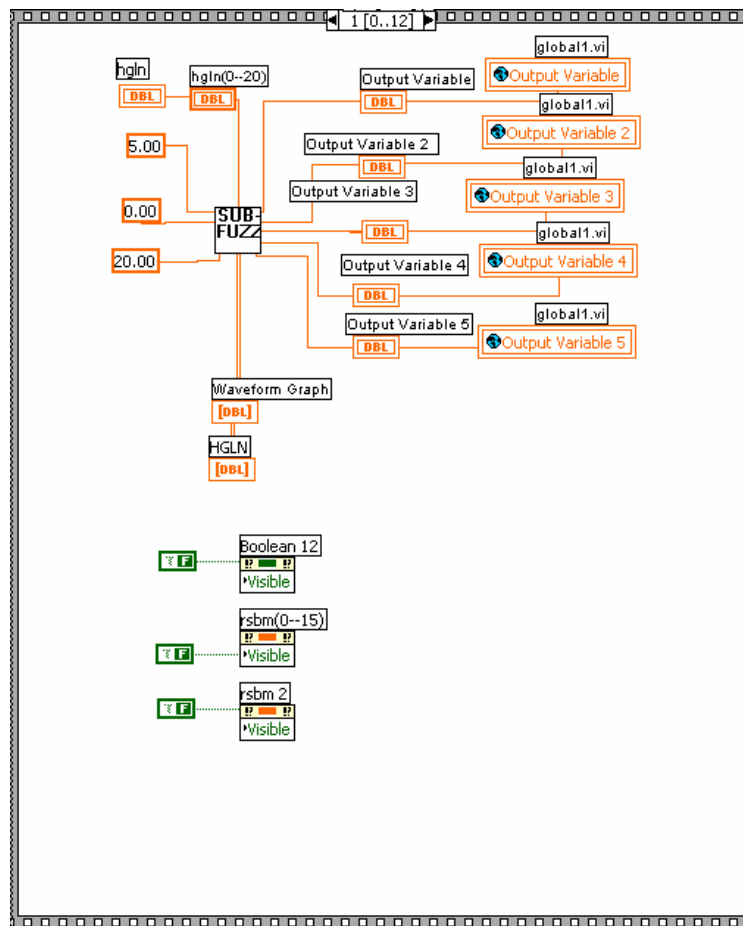
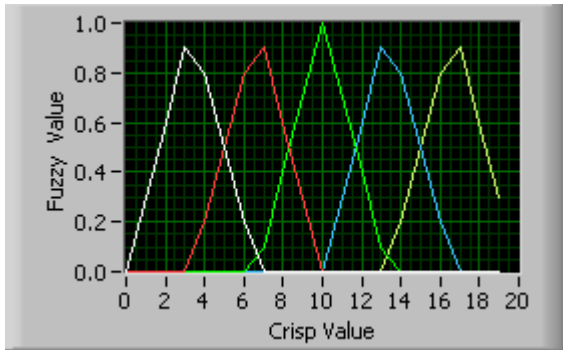
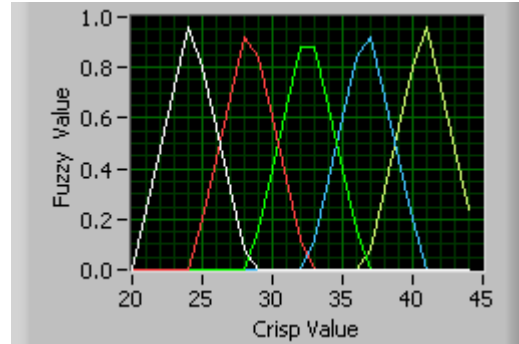

Figure 4.3: Block Diagram for calling Fuzzification Sub VI

The membership functions of the various fuzzy sets is shown in Figure 4.4 (a-l). The meanings of various colours are: White: Very low; Red: Low; Green: Medium/ Normal; Blue: High and Yellow: Very High.



**4.4 (a) Hemoglobin**



**4.4 (b) Hematocrit**

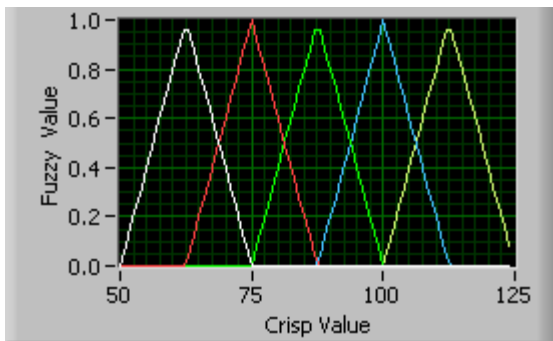

**4.4 (c) Mean Corpuscular Volume**

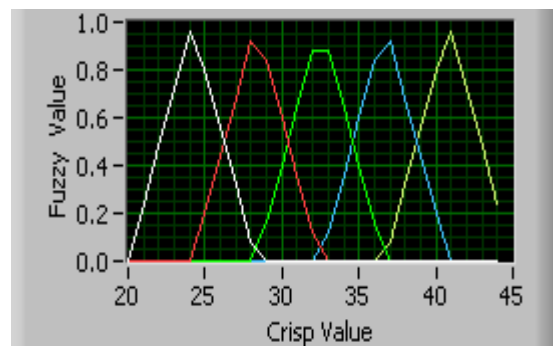

**4.4 (d) Mean Corpuscular Hemoglobin Concentration**

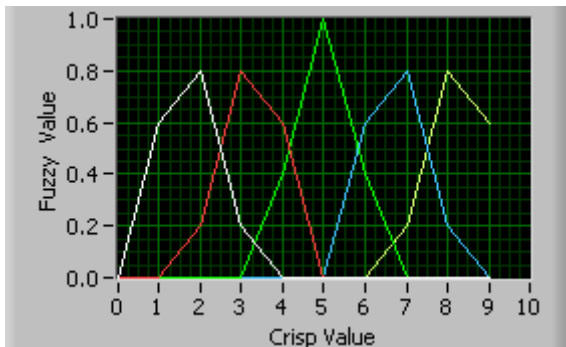

**4.4 (e) Reticulocyte Count**

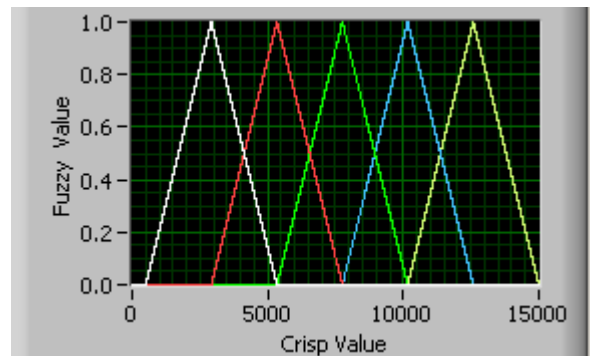

**4.4 (f) White Blood Cells**

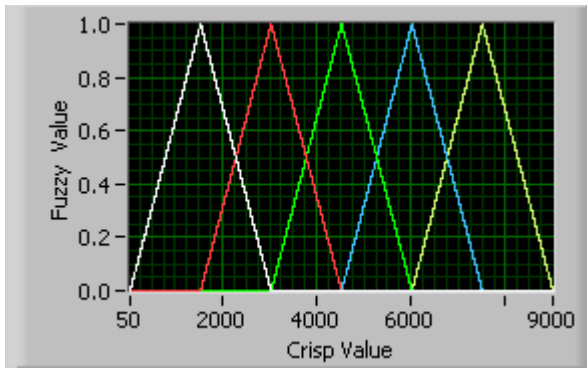

**4.4 (g) Platelets**

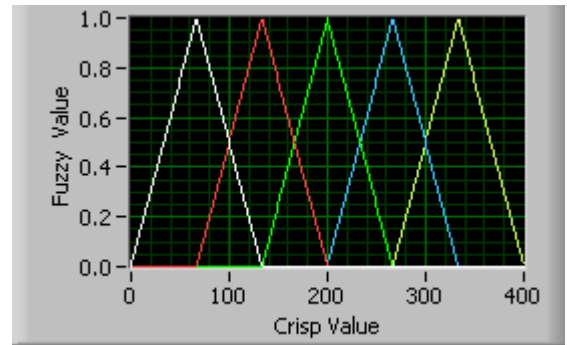

**4.4 (h) Total Iron Binding Capacity**

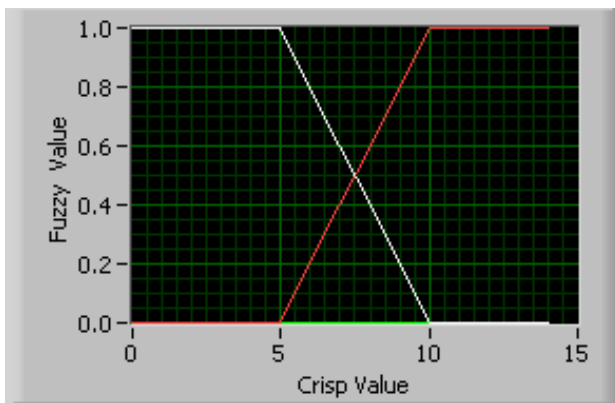

**4.4 (i) Nucleated Red Cells**

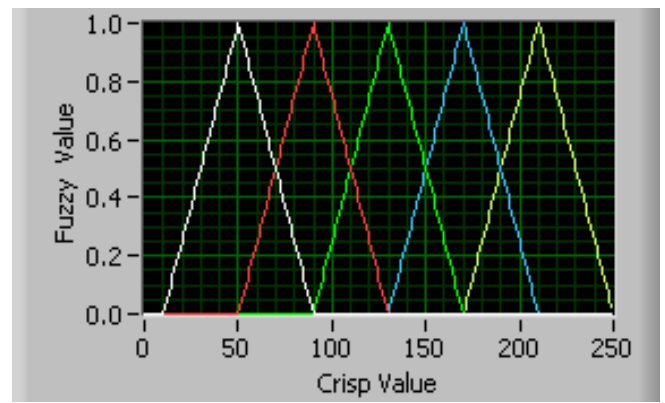

**4.4 (j) Serum Iron**

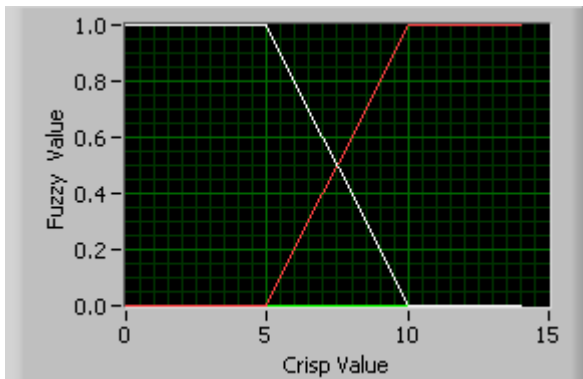

**4.4 (k) Hyper Segmented White Cells**

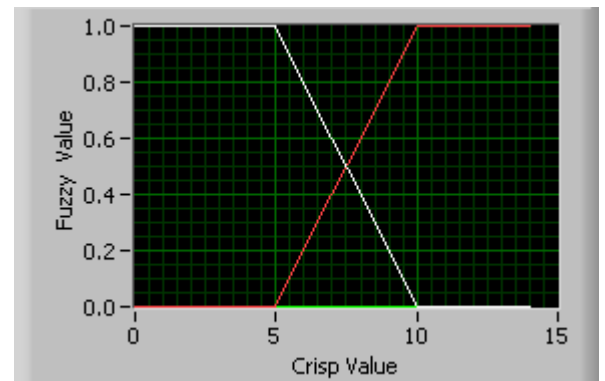

**4.4 (l) Ringed Sideroblasts in Bone Marrow**

**Figure 4.4 (a-l) : Membership values of various Inputs**

### 4.3.3 Rule Base

The next step after fuzzification is to get a result based on the weights of the inputs. Linguistic rules describing the control system consist of two parts; an antecedent block (between the If and Then) and a consequent block (following Then). Depending on the system, it may not be necessary to evaluate every possible input combination, since some may rarely or never occur [21]. By making this type of evaluation, fewer rules can be evaluated, thus simplifying the processing logic and perhaps even improving the Fuzzy Logic system performance.

The rule matrix is a simple graphical tool for mapping the Fuzzy Logic control system rules. It accommodates two input variables and expresses their logical product (AND) as one output response variable. To make the rule matrix, we define the system using plain-English rules based upon the inputs, decide appropriate output response conclusions, and load these into the rule matrix.

#### 4.3.3.1 Block Diagram

The following block diagram forms the rule base of the whole fuzzy control system according to which decisions of what the output should be is taken. It also uses rule base sub-vi which is explained in 4.4.2. The output of all the rules from 0-17 is being fed into build array block and is given to next sequence using sequence local.

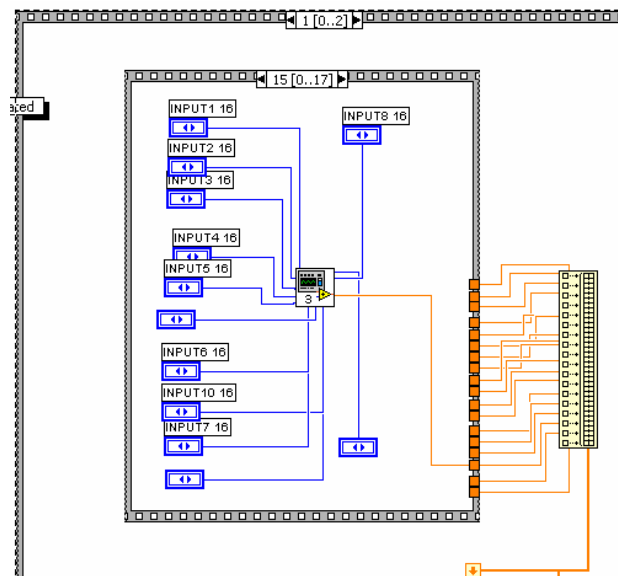
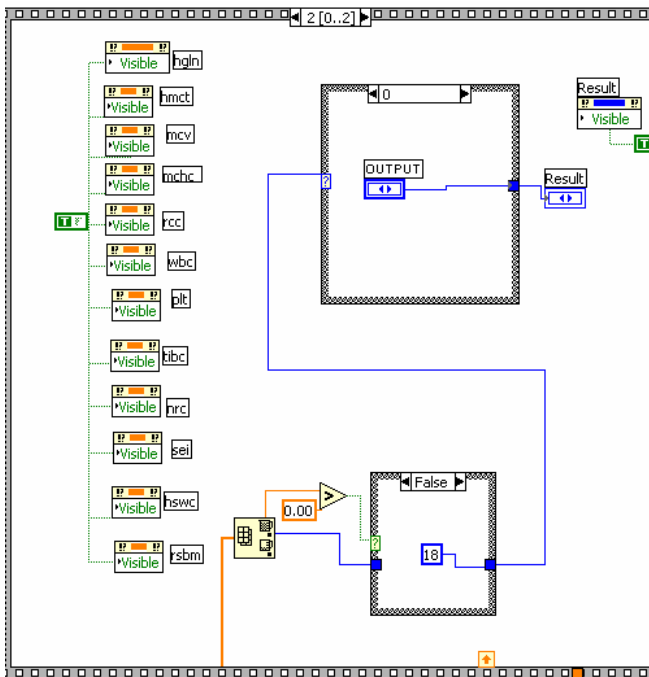

Figure 4.5: Block Diagram for calling Rule Base Sub VI

### 4.3.4 Defuzzification

The last step in the fuzzy control system is to defuzzy the output values and convert them in to actual crisp values. The output from the previous sequence obtained through sequence local is fed to max-min array block which finds out the maximum of index of rule base. This accordingly as the case provided for 18 anemia diseases gives the appropriate output.



a) Main Block diagram

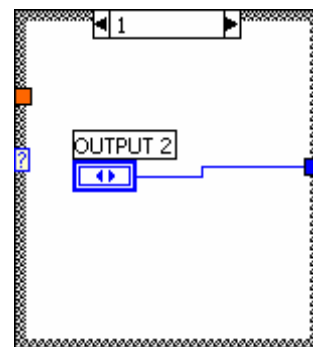

b) A particular Case

Figure 4.6 (a) and (b): Block Diagram for Defuzzification

## 4.4 Sub-VIs Used

### 4.4.1 Fuzzification Sub VI

The function is used to fuzzify different inputs and hence obtain membership values of the value in different fuzzy subsets. The following is the calling function which calls the sub VI from the main program.

The Flowchart for fuzzification is shown in Figure 4.7:

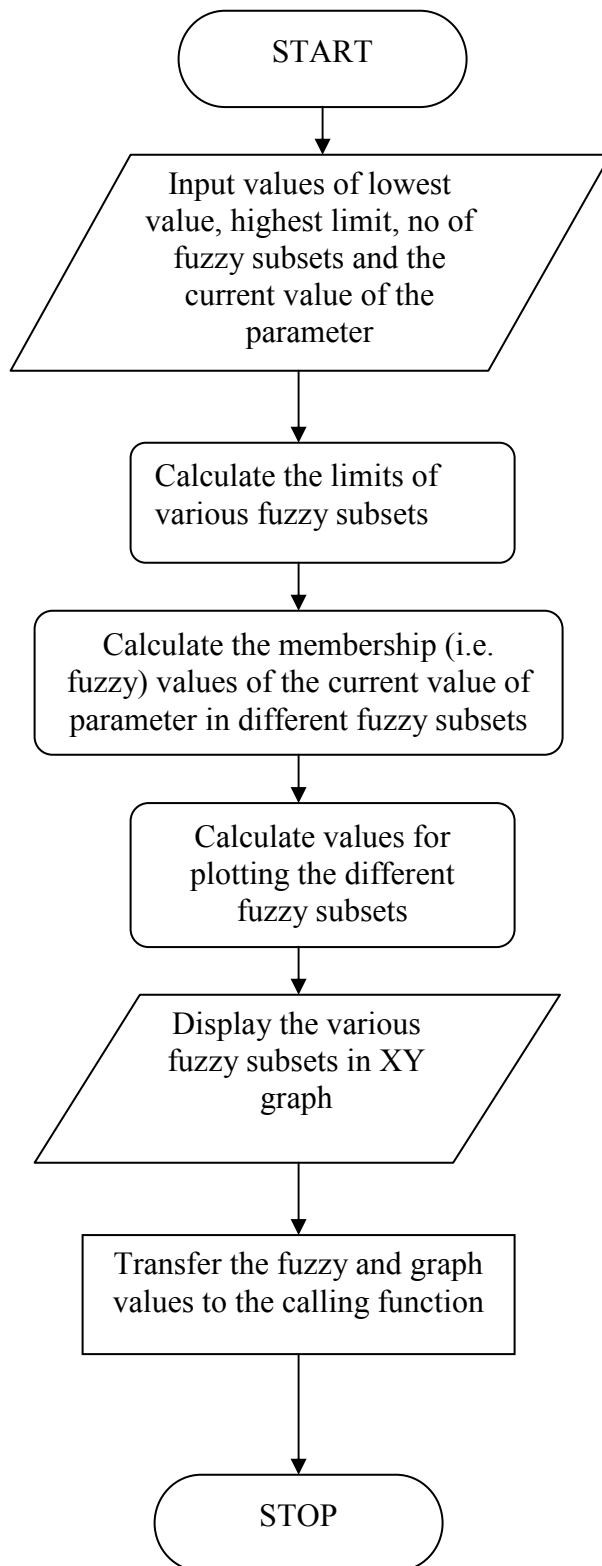

**Fig 4.7: Flowchart for Fuzzification Sub VI**

#### 4.4.1.1 Front Panel:

The front panel of the sub VI is shown in Figure 4.8.

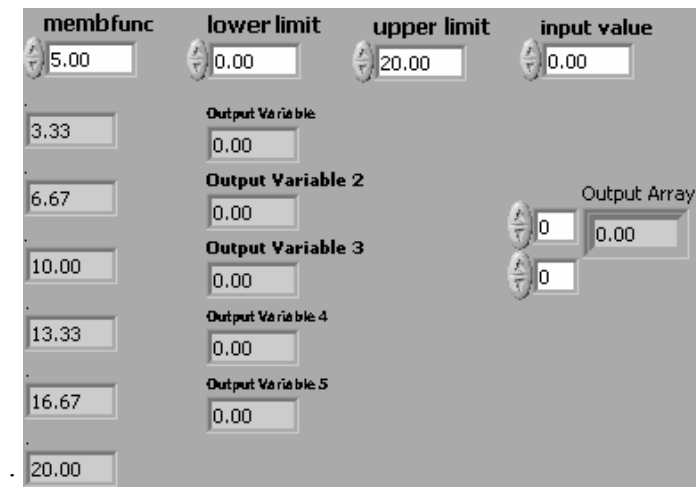

**Fig 4.8: Front Panel Fuzzification Sub VI**

#### 4.4.1.2 Block Diagram:

This block diagram takes input value and number of membership functions and calculates the number of points and ranges for different members viz very low, low, normal, high and very high. The formula node using these points calculates the fuzzified values using equations and gives output ranging from 0-1.

#### 4.4.2 Rule Base Sub VI

The flowchart for rule based inference done in this Sub VI is as shown in Figure4.9.

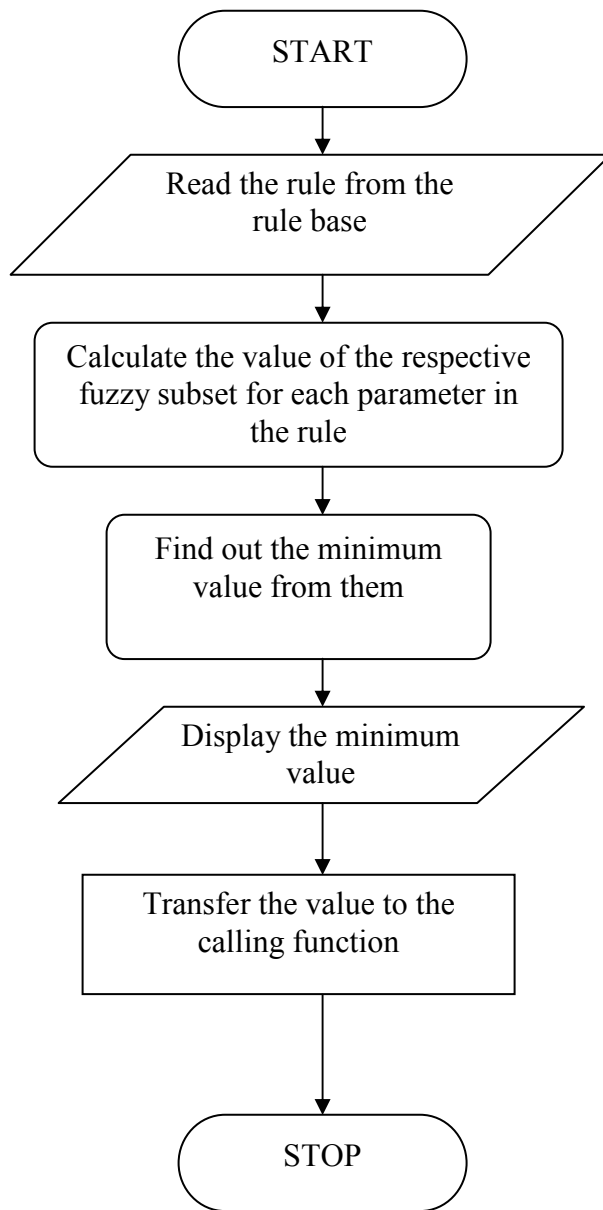

**Fig 4.9: Flowchart for Rule Base Sub VI**

### 4.4.2.1 Front Panel

The front panel of the sub VI is shown in Figure 4.10.

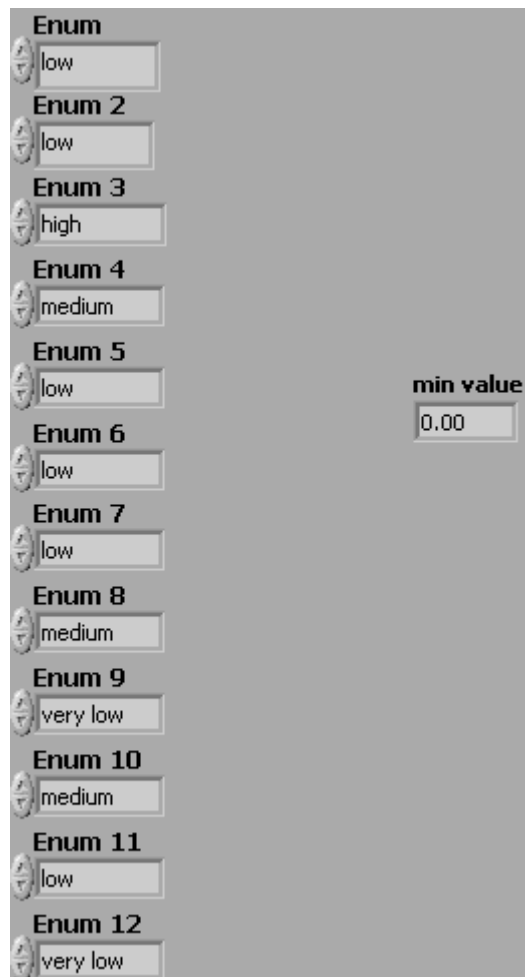

Fig 4.10: Front Panel Rule Base Sub VI

### 4.4.2.2 Block Diagram:

This block diagram gives the minimum value (following the simple logic of Anding of different inputs in fuzzy logic). The global variables obtained after fuzzification of data used here in cases for their specific input and according to the rule base provided by the user selects the appropriate member and gives the output.

## Results and Conclusions

### 5.1 Result 1

The results, for a given set of inputs, after various steps are as follows:

#### 5.1.1 Input Values

The values of different parameters is entered via the respective control palettes on the front panel. The front panel after respective inputs are fed in the program is as shown in Figure 5.1 (a-1).

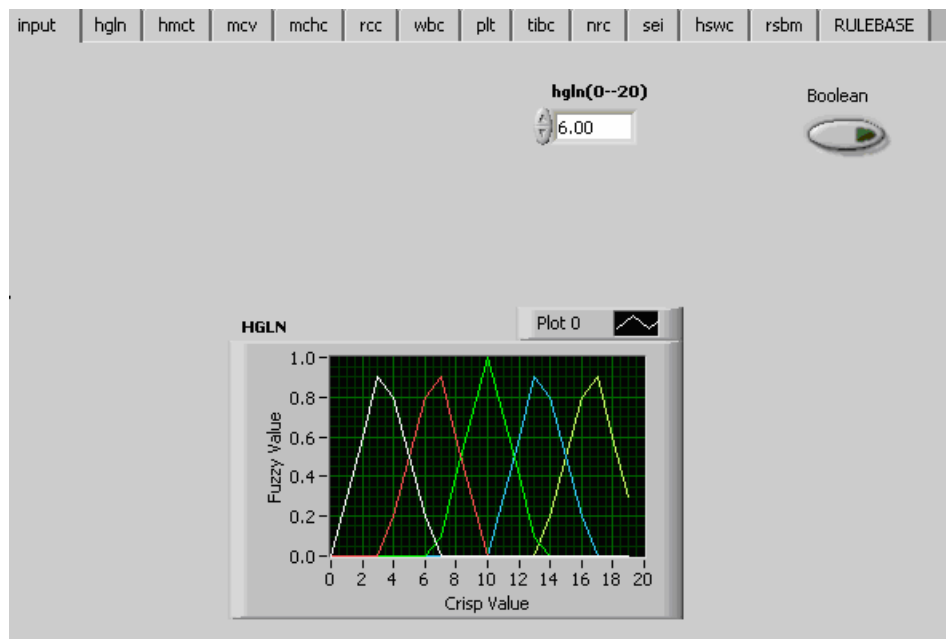

**5.1 (a) Input 1: Hemoglobin (hgl). Value = 6**

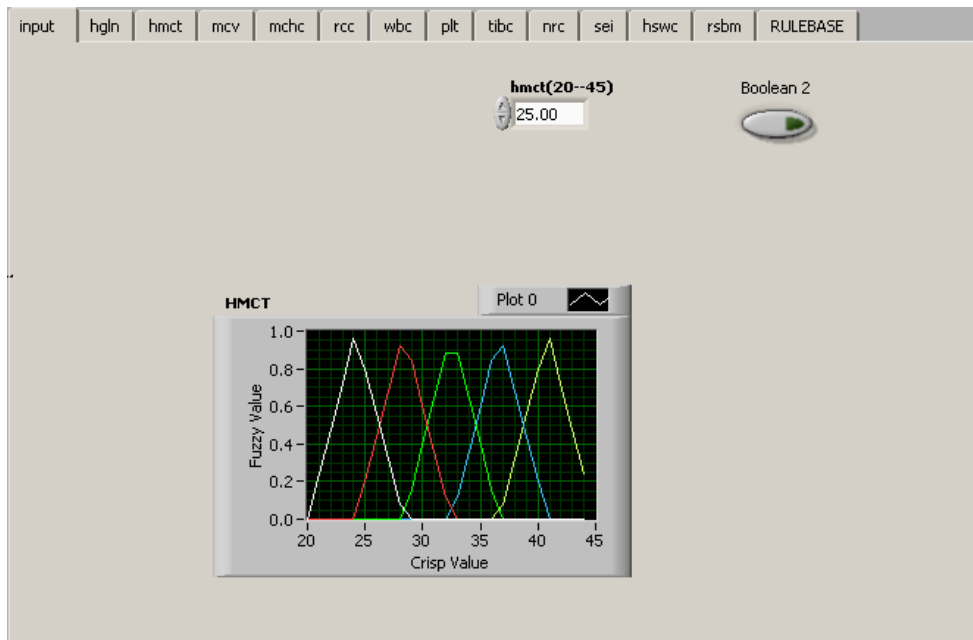

**5.1 (b) Input 2: Hematocrit (hmct). Value = 25**

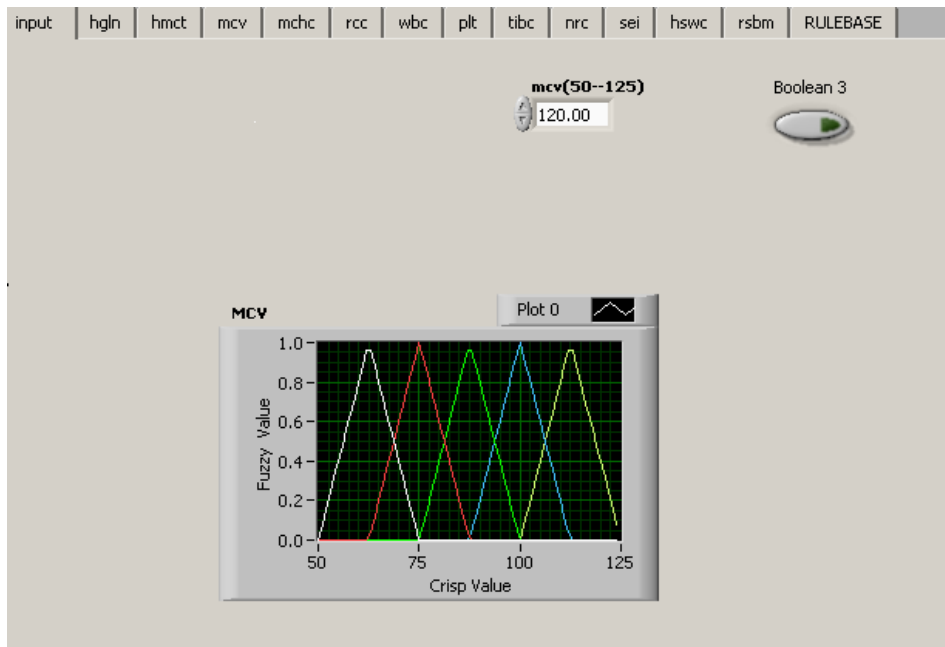

**5.1 (c) Input 3: Mean Corpuscular Volume (mcv). Value = 120**

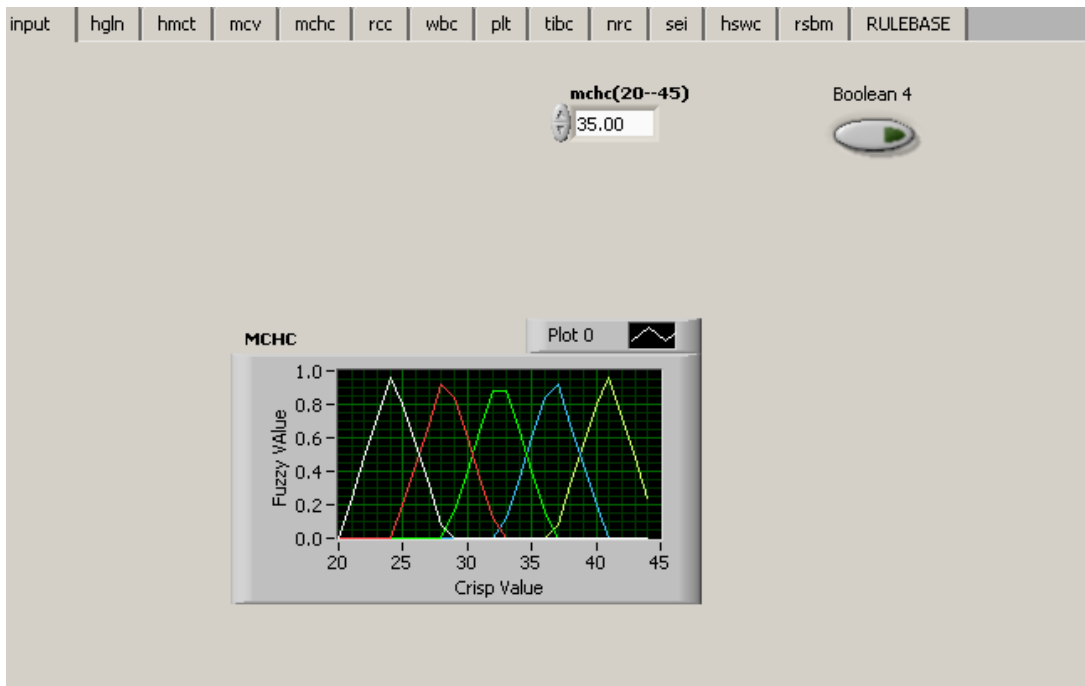

**5.1 (d) Input 4: Mean Corpuscular Hemoglobin Concentration (mchc). Value = 35**

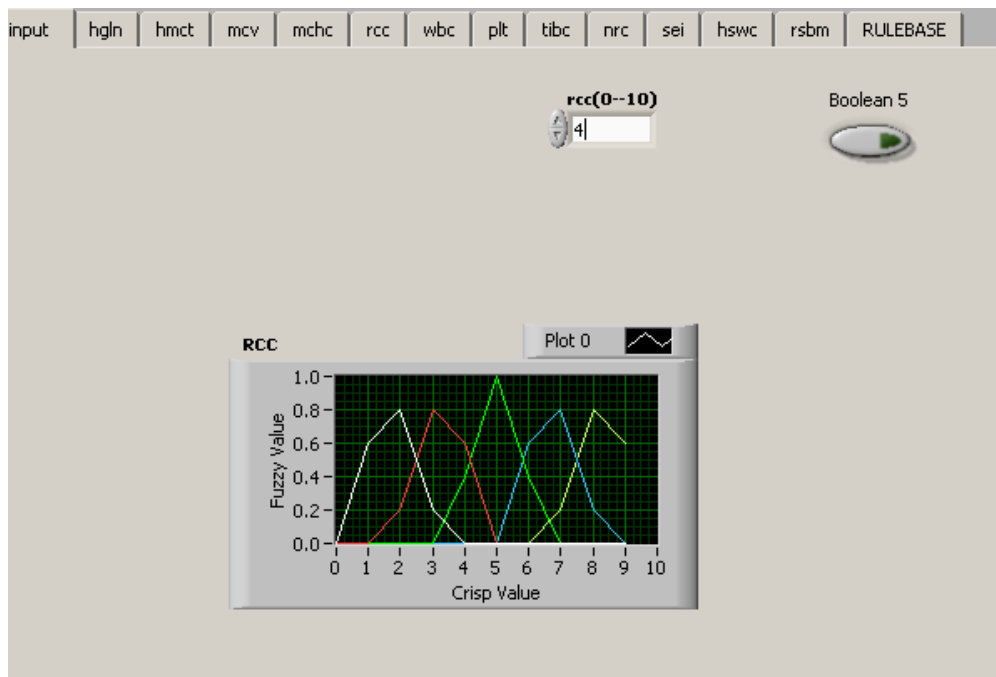

**5.1 (e) Input 5: Reticulocyte Count (rcc). Value = 4**

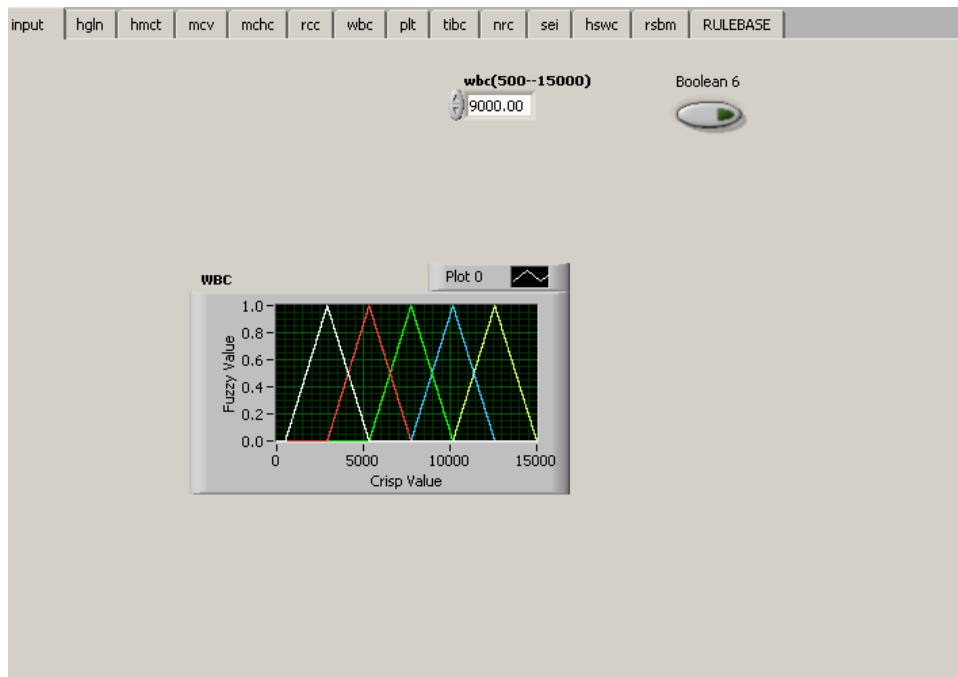

**5.1 (f) Input 6: White Blood Cells (wbc). Value = 9000**

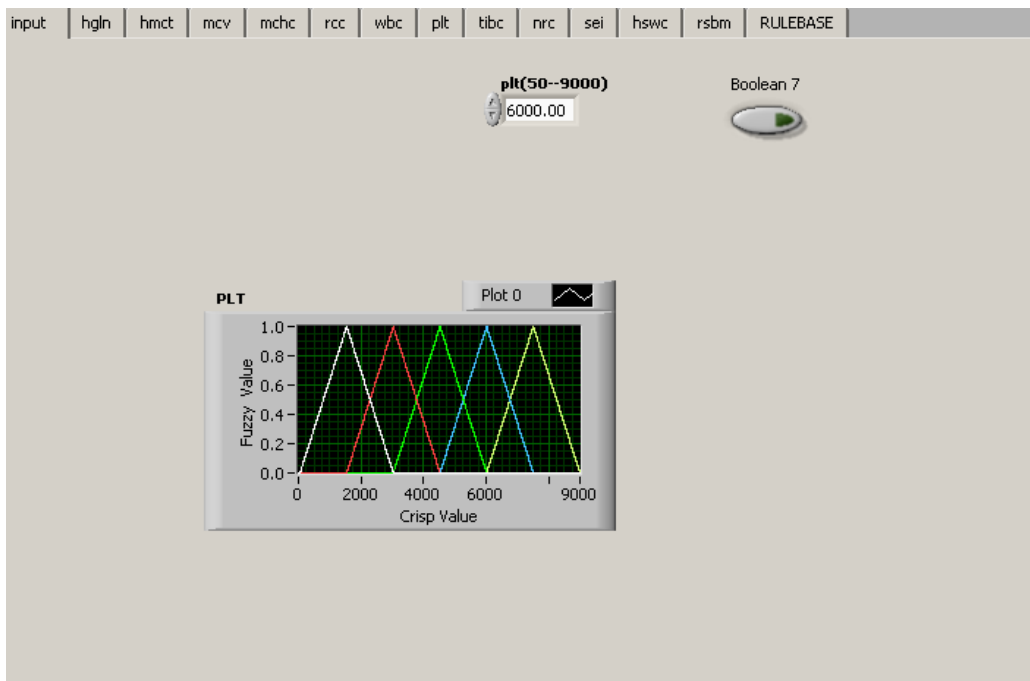

**5.1 (g) Input 7: Platelet (plt). Value = 6000**

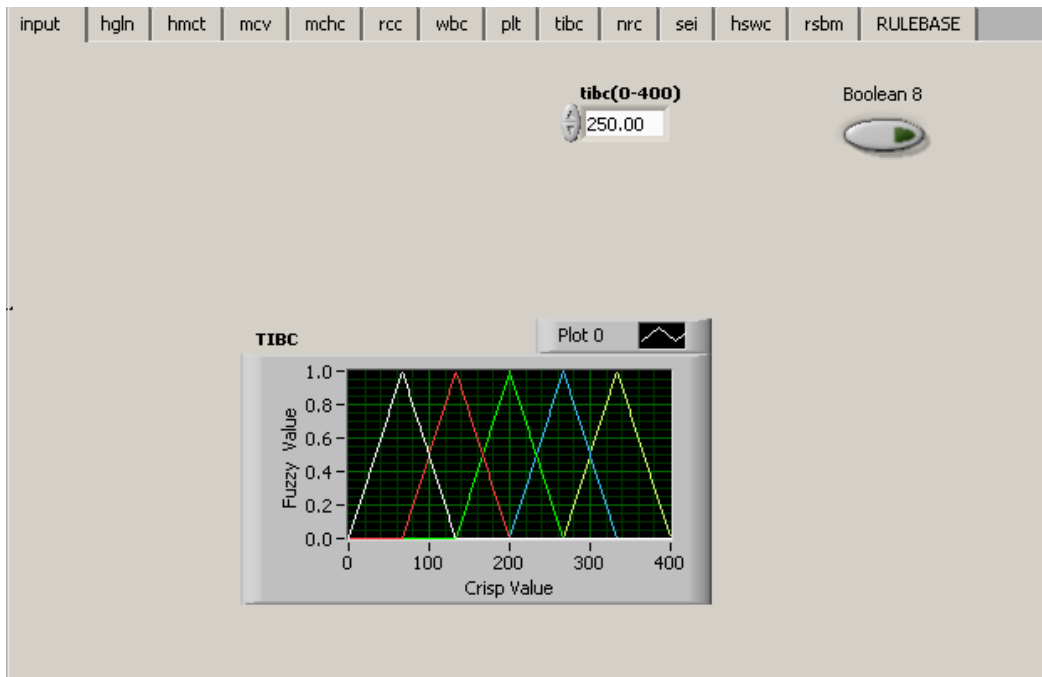

**5.1 (h) Input 8: Total Iron Binding Capacity (tbc). Value = 250**

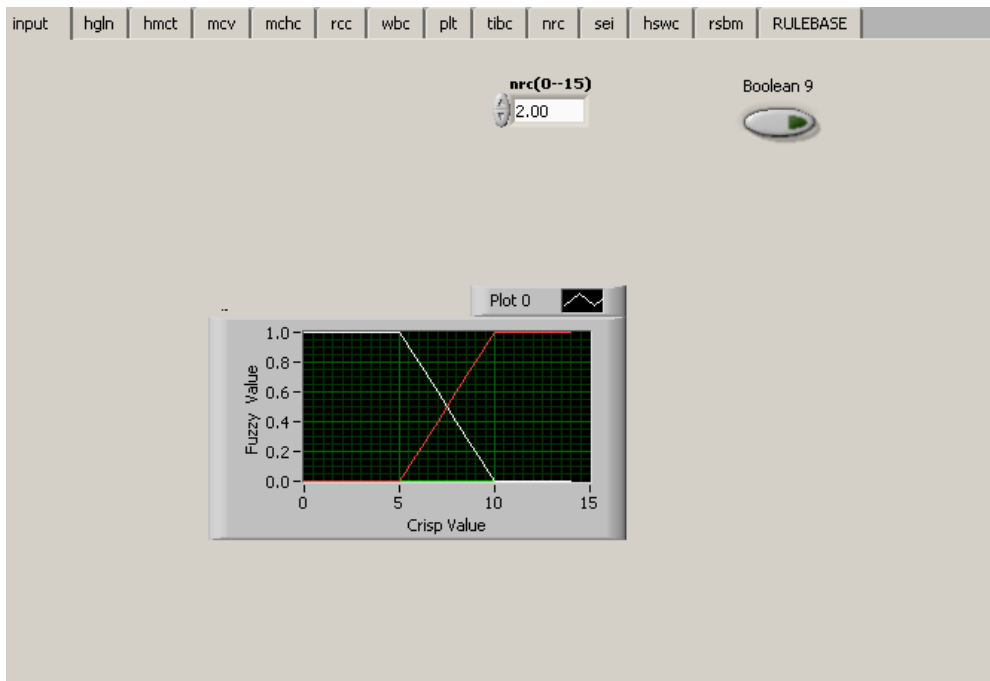

**5.1 (i) Input 9: Nucleated RBCs (nrc). Value = 2 i.e. not present**

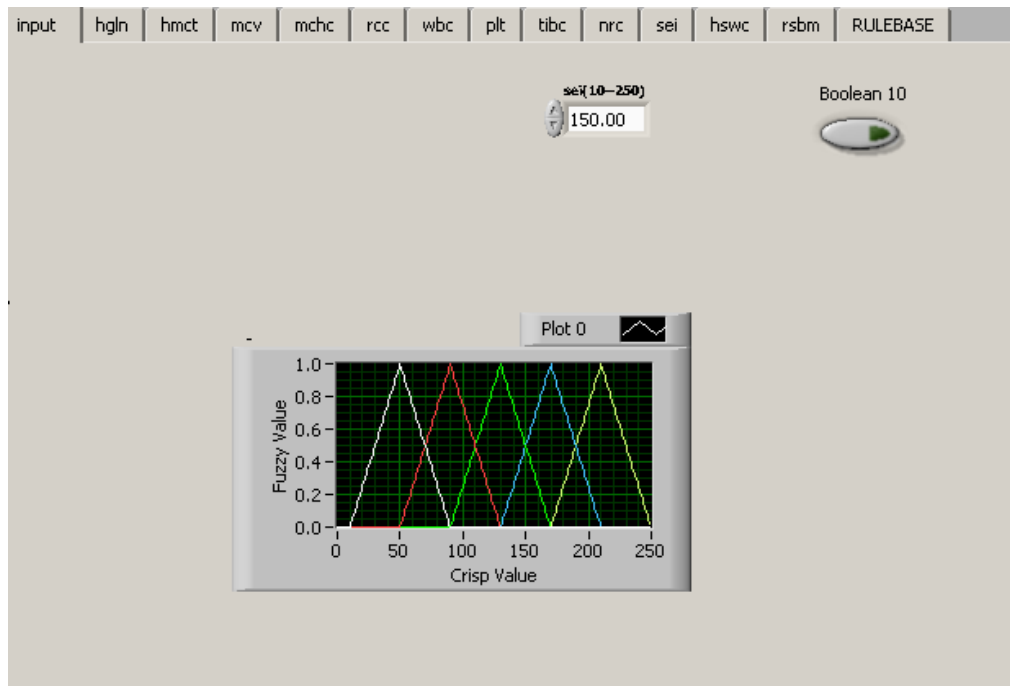

**5.1 (j) Input 10: Serum Iron (sei). Value = 150**

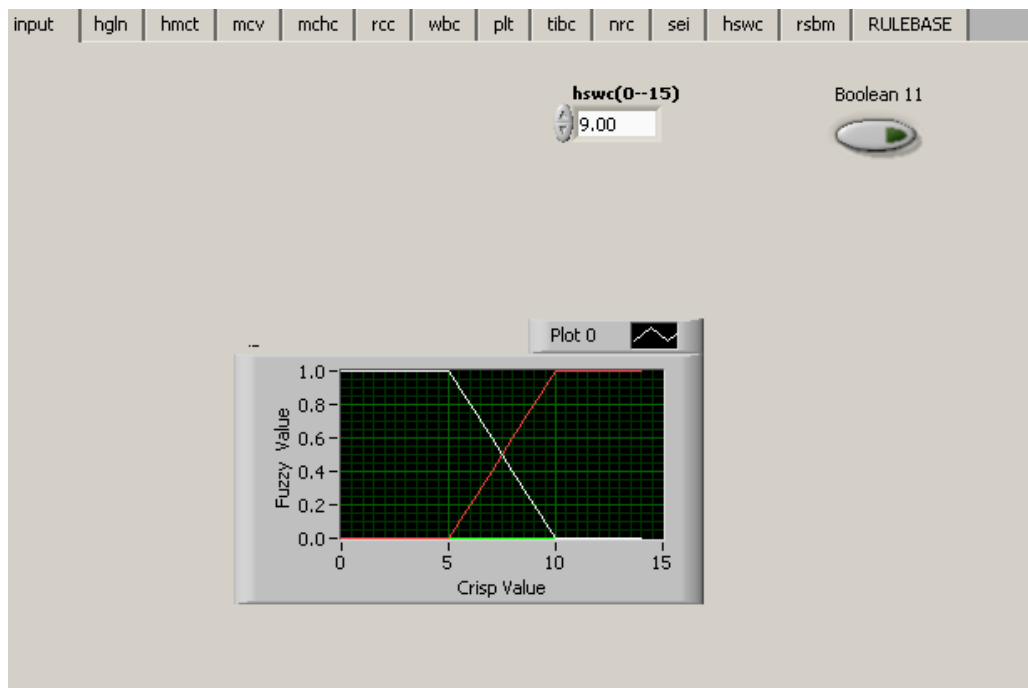

**5.1 (k) Input 11: Hyper Segmented White Cells (hswc). Value = 9 i.e. present**

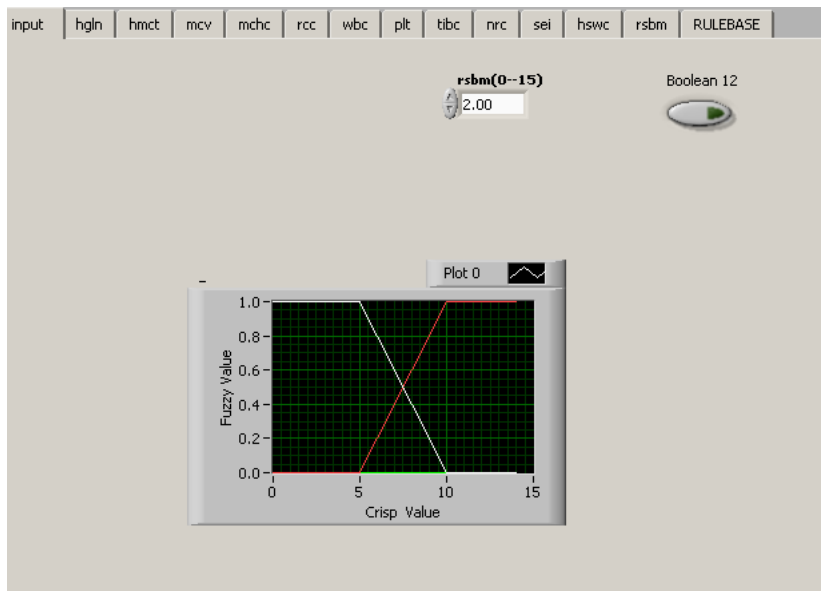

**5.1 (l) Input 12: Ringed Sideroblasts in Bone Marrow (rsbm). Value = 2 i.e. not present**

**Fig 5.1 (a – l): Front panels for entering various inputs**

### 5.1.2 Fuzzification

The crisp values are then fuzzified using the respective sub VIs. The values of different fuzzy sub sets for total iron binding capacity is as shown in Figure 5.2.

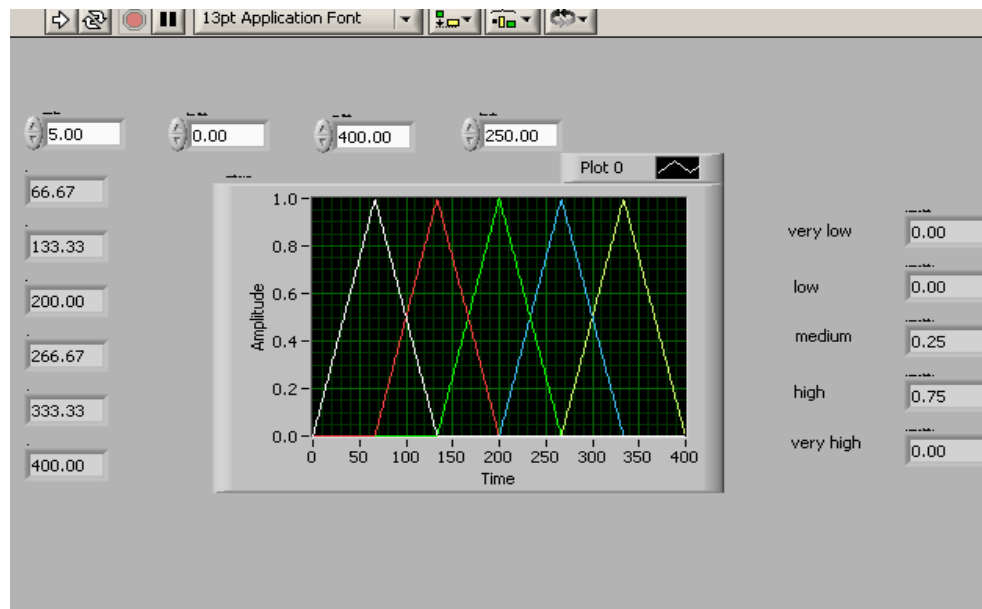

**Figure 5.2: Fuzzification front panel for TIBC**

### 5.1.3 Rule Base

The rule base applies the various rules to the fuzzy inputs and gives the output in terms of fuzzy values. The function used is min or AND of the various rules. The output for rule 15 which is true in this case is as shown in Figure 5.3.

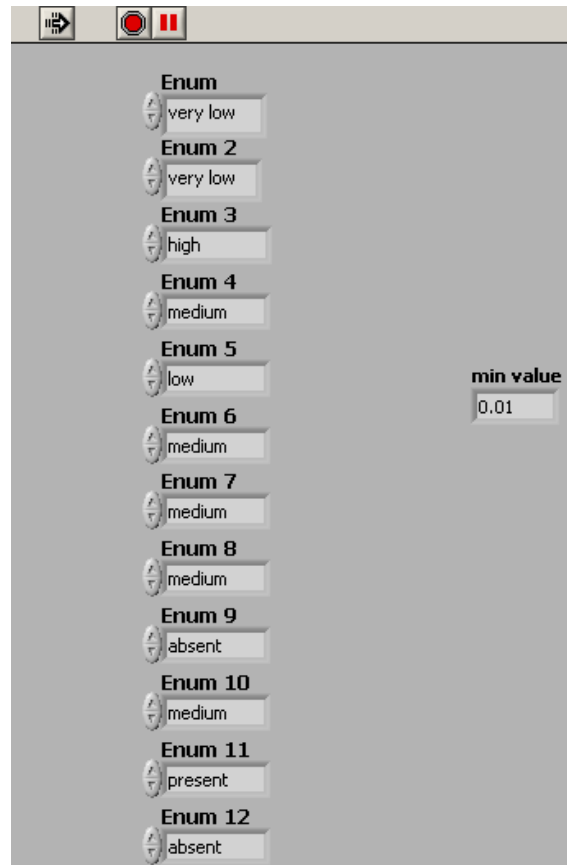

Figure 5.3: Rule Base front panel for Rule 15

### 5.1.4 Defuzzification and Diagnosis

In the defuzzification, the maximum value of membership of various outputs is taken. Finally the result is displayed which indicate the type of anemia the person suffers from as shown in Figure 5.4.

input	hgn	hmct	mcv	mchc	rcc	wbc	plt	tibc	nrc	sei	hswc	rsbm	RULEBASE
-------	-----	------	-----	------	-----	-----	-----	------	-----	-----	------	------	----------

<b>hgn</b>	6.00	<b>plt</b>	6000.00
<b>hmct</b>	25.00	<b>tibc</b>	250.00
<b>mcv</b>	120.00	<b>nrc</b>	2.00
<b>mchc</b>	35.00	<b>sei</b>	150.00
<b>rcc</b>	4.00	<b>hswc</b>	9.00
<b>wbc</b>	9000.00	<b>rsbm</b>	2.00

**Result**

**high megalow**

**Figure 5.4: Result 1: High Megaloblastic Anemia.**

## 5.2 Result 2

A different set of inputs is given in this case. All the above steps are followed by the program and the diagnosis is shown in Fig 5.5.

input	hgl	hmct	mcv	mchc	rcc	wbc	plt	tbc	nrc	sei	hswc	rsbm	RULEBASE
	2.00	25.00	80.00	30.00	2.00	1000.00	100.00	250.00	2.00	110.00	2.00	2.00	

**Result**

**high aplastic anemia**

Figure 5.5: Result 2: High Aplastic Anemia.



## 5.4 Conclusion

The above program illustrates a novel approach to design a disease diagnostic system using the concept of fuzzy logic in LABVIEW. The different types of anemias are diagnosed, using results of laboratory test, and reported immediately. The program has given consistently accurate results for various cases thus ensuring that the system is reliable and robust.

This software implementation can serve as an expert system and can be utilized by any medical practitioner to diagnose anemia. In fact due to interactive and use friendly front panel any non medical person can also utilize it for diagnostic purposes. The flexibility and the modifiability of the rule base facilitates setting up of different set of rules that can be useful for diagnosis of other diseases apart from anemia.

We hope that our effort will contribute to the noble task of the worldwide crusade against diseases and that it will serve the needs of millions around the world.

## 5.5 Scope of Future Work

Further improvements that can be incorporated in this software are:

- Implementing various methods of defuzzification of data other than max method that has been used here viz. centroid, mean, min, root mean square method.
- To make program more user friendly if a user makes a mistake in entering the input data from the front panel in between entering of inputs we can incorporate the facility of stop button in the software to stop the program and change the value of the input accordingly.
- The program detects some major types of anemias. It can be further extended to detect other types of anemias like sickle cell anemia, thalassemia etc.
- The rule base is modifiable, hence it can be modified to test for any other disease other than anemia also.

# Appendix

## Rule Base

input	hgn 2	hmcv	hmtc	mchc	rcc	wbc	plt	tbtc	nrc	sei	hswc	rsbm	RULEBASE	OUTPUT
very low	hmcv 2 very low	mchc 2 medium	rcc 2 low	wbc 2 very low	plt 2 very low	tbtc 2 medium	nrc 2 absent	sei 2 medium	hswc 2 absent	rsbm 2 absent	OUTPUT high aplastic			
very low	low	medium	low	low	very low	medium	absent	medium	absent	absent	OUTPUT 2 medium			
low	medium	medium	low	low	low	medium	absent	medium	absent	absent	OUTPUT 3 low aplas			
very low	very low	medium	low	medium	medium	low	absent	low	absent	absent	OUTPUT 4 high chronic			
very low	low	low	medium	medium	medium	low	absent	low	absent	absent	OUTPUT 5 medium			
low	low	medium	medium	medium	medium	low	absent	medium	absent	absent	OUTPUT 6 low cronic			
very low	very low	low	low	medium	medium	high	absent	low	absent	absent	OUTPUT 7 high iron def			
very low	low	low	low	medium	medium	high	absent	low	absent	absent	OUTPUT 8 med iron def			
low	low	low	low	low	medium	high	absent	low	absent	absent	OUTPUT 9 low iron def			
low	low	low	medium	medium	medium	high	absent	high	absent	present	OUTPUT 10 sideroblastic			
low	low	medium	medium	medium	medium	high	absent	high	absent	present	OUTPUT 11 sideroblastic			
low	low	high	high	medium	medium	high	absent	high	absent	present	OUTPUT 12 sideroblasti			
low	low	medium	low	medium	medium	medium	present	medium	absent	absent	OUTPUT 13 mylophthisic			
low	low	medium	low	medium	low	medium	present	medium	absent	absent	OUTPUT 14 mylophthisic			
low	low	medium	low	medium	low	medium	present	medium	absent	absent	OUTPUT 15 mylophthisic			
very low	very low	medium	low	medium	medium	medium	absent	medium	present	absent	OUTPUT 16 high megalo			
very low	low	high	very low	medium	low	medium	absent	medium	present	absent	OUTPUT 17 megaloblasti			
low	low	high	low	low	low	medium	absent	medium	present	absent	OUTPUT 18 C			

# Glossary

[25, 26, 27]

---

**Acute:** used to describe a disease that is brief, severe, and quickly comes to a crisis

**Atrophy:** the shrinking in size of some part or organ of the body, usually caused by injury, disease, or lack of use

**Basal Ganglia:** a mass of gray matter that lies in the white matter near the base of each cerebral hemisphere of the brain. The basal ganglia help to regulate the body's voluntary movements.

**Bone Marrow:** a soft reddish substance inside some bones that is involved in the production of blood cells. New white and red blood cells are formed only in the marrow of the flat bones such as the ribs, breastbone, or pelvis in adults

**Chronic:** used of an illness or medical condition that lasts over a long period and sometimes causes a long-term change in the body

**Clostridium:** a rod-shaped, usually motile, Gram-positive bacterium that can cause serious illnesses including botulism, tetanus, and gas gangrene.

**Complement Fixation:** the process in which a group of blood proteins (complement) is bound to a specific combined antibody-antigen pair as part of the immune reaction to foreign cells

**Erythroblast:** an immature red blood cell that is found in bone marrow and eventually develops into a mature red blood cell. Unlike a mature red blood cell, an erythroblast has a nucleus

**Erythropoietin:** a hormone produced in the kidneys that stimulates increased development of red blood cells in the bone marrow. The kidneys produce erythropoietin in response to lowered oxygen levels in body tissues.

**Exogenous:** originating outside an organism or system

**Extravascular:** not contained in the body's blood vessels or lymph vessels

**Hematocrit:** the percentage of a blood sample that consists of red blood cells, measured after the blood has been centrifuged and the cells compacted

**Hematology:** the branch of medicine devoted to the study of blood, blood-producing tissues, and diseases of the blood

**Hematopoiesis:** the formation of red blood cells in the blood-forming tissues of the body

**Hemoglobin:** an iron-containing protein in red blood cells that combines reversibly with oxygen and transports it from the lungs to body tissues

**Hemolytic:** the destruction of red blood cells and the release of the hemoglobin they contain

**Hemorrhage:** the loss of blood from a ruptured blood vessel, either internally or externally

**Hypertrophy:** a growth in size of an organ through an increase in the size, rather than the number, of its cells

**Hypoxia (anoxia):** an inadequacy in the oxygen reaching the body's tissues

**Ganglion:** a structure that contains a dense cluster of nerve cells

**Intravascular:** within the blood vessels or a similar system in animals or plants

**Isohemagglutinins:** an agglutinin capable of causing RBCs to agglutinate (clump together and settle down) when blood of one member of a species is administered to another member of the same species.

**Ischemia:** an inadequate supply of blood to a part of the body, caused by partial or total blockage of an artery

**Granulocyte:** a white blood cell that contains many granular particles in its cytoplasm

**Haptoglobin:** any of several plasma proteins that combine with free hemoglobin in the bloodstream

**Hemosiderin:** a protein that stores iron

**Macrocyte:** an unusually large red blood cell that commonly occurs in cases of anemia

**Mean Corpuscular Volume:** The mean volume of a body. In our case it is RBC.

**Mean corpuscular hemoglobin concentration:** Mean concentration of hemoglobin in the corpuscle

**Medulla:** the innermost area of a part or organ of an animal or plant

**Methemoglobin:** an abnormally altered form of hemoglobin that can occur as a result of poisoning with certain drugs or as a genetic disorder

**Myocardium:** the thick muscular wall of the heart. The myocardium is thickest around the left ventricle where the pressure generated by the heart is greatest

**Necrosis:** the death of cells in a tissue or organ caused by disease or injury

**Palpitation:** an irregular or unusually rapid beating of the heart, either because of a medical condition or because of exertion, fear, or anxiety

**Paroxysm:** a sudden and uncontrollable expression of emotion

**Peritoneum:** a smooth transparent membrane that lines the abdomen and doubles back over the surfaces of the internal organs to form a continuous sac

**Platelet:** see **Thrombocyte**

**Reticuloendothelial system:** collections of large phagocytes and endothelial cells found in the liver, spleen, bone marrow, and elsewhere

**Reticulocyte:** an immature red blood cell containing a network of fibers of ribosomal remains that show up with laboratory staining

**Sepsis:** the condition or syndrome caused by the presence of microorganisms or their toxins in the tissue or the bloodstream

**Serum:** the fluid that separates from clotted blood, similar to plasma but without clotting agents

**Sidero-** : Prefix pertaining to Iron

**Sideroblasts:** Iron generating bodies

**Siderosis:** an abnormal accumulation of iron in the blood and tissues

**Smear:** a sample of cells taken from body tissue or a bodily secretion or discharge and smeared on a microscope slide for examination

**Splenomegaly:** abnormal enlargement of the spleen

**Thrombocyte (platelet):** a tiny colorless disk-shaped particle found in large quantities in the blood that plays an important part in the clotting process

**Thrombus (Pl. Thrombi):** a blood clot that forms in a blood vessel and remains at the site of formation

**White blood cells:** a common large blood cell that has no pigmentation. It helps protect the body against infection in the immune response, and also plays a role in inflammation and allergic reactions

# References

---

1. Crawley Jane, “*Reducing the burden of Anemia in infants and young children in Malaria endemic countries of Africa, From evidence to action*”, Roll Back Malaria Department, WHO, Geneva, Switzerland, 2006
2. Richard E., Brenda W.J.H. and Woodman, Richard C., “*Anemia in the elderly: Current understanding and emerging concepts*”, Temple University of Medicine, Philadelphia, USA, 2006
3. Schier, Stanley L., “*Approach to the adult patient with anemia*”, American Academy of Family Physicians, June 2005
4. Conrad, Marcel E., “*Iron Deficiency Anemia.*”, Emedicine Journal, 8 December 2004
5. Middleton, J.R., “*Haematology of South American camelidae*”, Selected Research on Camelid Physiology and Nutrition, The Camelid Publishers, Bikaner, India, 2004
6. M. A Aref, K. M. Elleithy, T. Sobh, “*Developing an Intelligence Web Based Expert System for Anemia Diagnosis and Categorization*”, U.S. Egypt Joint Board on Scientific and Technological Cooperation, Proposal, October 2001
7. Mitra S., .Pal S.K and Mitra P., “*Data mining in soft computing framework: a survey*”, IEEE Transactions on Neural Networks, vol. 13, no. 1, 2002
8. J.F. Roddick and M. Spiliopoulou, “*A survey of temporal knowledge discovery paradigms and methods*”, IEEE Transactions on Knowledge and Data Engineering, vol. 14, no. 4, 2002
9. Jain A.K., Duin R.P.W. and Mao J., “*Statistical pattern recognition: a review,*” IEEE Transactions on Pattern Analysis and Machine Intelligence, vol. 22, no. 1, 2000
10. Murray S.L., Lau K.W., Begg A., Jacobs K, “*Myelodysplasia, hypophosphataemia, Vitamin D, and iron deficiency in an alpaca*”, Australian Veterinary Journal, May 2001
11. Johnson, L.W., “*EPE: What's it all about?*”, The Ohio State University College of Veterinary Medicine Presents Camelid Medicine, Surgery and Reproduction, March 22-25, 2000
12. Andrews, A.H., “*Suspected nutritional deficiency causing anaemia in llamas (Lama glama)*”, Royal Veterinary College, North Mymms, Hatfield, Feb 8, 1997

13. Lozoff B et al, "*Poorer behavioral and developmental outcome more than 10 years after treatment for iron deficiency in infancy*", Pediatrics Journal, April 2000
14. Kilbride J et al, "*Incidence of iron-deficiency anaemia in infants in a prospective study in Jordan*", Eur J Haematol Journal, 2000
15. Bogen DL et al , "*Screening for iron deficiency anemia by dietary history in a high-risk population*", Pediatrics Journal, June 2000
16. Breymann, Christian, "*Iron Deficiency and Anemia in Pregnancy: Modern Aspects of Diagnosis and Therapy.*", Blood Cells, Molecules, and Diseases Journal, Nov/Dec, 2002.
17. Raymond, Tina, "*Anemia: Diagnosis, Treatment and Prevention.*", Midwifery Today, 31 May 1999.
18. Beard JL, "*Effectiveness and strategies of iron supplementation during pregnancy*", Ohio State University, Columbus, USA, 2000 May;71 .
19. Smith, B.B.; Reed, P.J.; Pearson, E.G.; Long, P.; Lassen, E.D.; Watrous, B.J.; Lovelady, S.; Sims, D.E.; Snyder, S.P., "*Erythrocyte dyscrasia, anemia, and hypothyroidism in chronically underweighed*". Journal of the American Medical Association, Jan 1, 1991
20. Battle, J; Casals, A; Freixenet, J. and Marti J., "*A review on strategies for recognizing natural objects in colour images of outdoor scenes*", Image and Vision Computing Journal, vol. 18, no. 6-7, 2000
21. Austin J, "*Distributed Associative Memories for High Speed Symbolic Reasoning*", International Journal on Fuzzy Sets and Systems, Vol. 82, 2002
22. Cotran, Kumar and Robbins, "*Pathologic Basis of Diseases*", 5<sup>th</sup> edition 1994, W.B. Saunders Company, Pennsylvania, pp-586-616
23. Bhatia and Tyagi, "*Elementary Biology (A Complete Test Book)*", Vol II, 8<sup>th</sup> edition 1997-98, Trueman Book Company, Jalandhar, pp: 9-55, 143-173
24. Bhatia and Tyagi, "*Elementary Biology (A Complete Test Book)*", Vol I, 8<sup>th</sup> edition 1997, Trueman Book Company, Jalandhar, pp: Unit 2
25. Dorland's Pocket Medical Dictionary, 21<sup>st</sup> Edition 1976, Oxford and IBH Publishing Co., New Delhi, Bombay and Calcutta.
26. Encyclopedia Britannica 2005
27. Encarta Reference Library 2005
28. [www.hematologica.org](http://www.hematologica.org)
29. [www.sciencedirect.com](http://www.sciencedirect.com)
30. [www.wikipedia.org](http://www.wikipedia.org)

31. [www.yahoo.com](http://www.yahoo.com)
32. [www.fuzzytech.com](http://www.fuzzytech.com)
33. [www.freebooks4doctors.com](http://www.freebooks4doctors.com)
34. [www.ni.com](http://www.ni.com)