

# **DESIGN AND ANALYSIS OF FRACTAL ANTENNAS FOR WIDEBAND, 3 – 8 GHz FREQUENCY RANGE**

*A Dissertation Submitted in Partial Fulfillment of the Requirement for the Award of the  
Degree of*

**MASTER OF ENGINEERING**

In

**WIRELESS COMMUNICATION**

Submitted By

**MALVIKA**

Roll No. 801563013

Under Supervision of

**Dr. Rana Pratap Yadav**

Assistant Professor, ECED



**ELECTRONICS AND COMMUNICATION ENGINEERING DEPARTMENT**

**THAPAR UNIVERSITY, PATIALA, PUNJAB**

**JULY, 2017**

## DECLARATION

I, Malvika hereby declare that the work presented in this thesis entitled "Design and Analysis of Fractal Antennas for Wideband, 3 – 8 GHz Frequency Range" in partial fulfillment of the requirement for the award of degree of Master of Engineering submitted at Electronics and Communication Engineering Department, Thapar University, Patiala is an authentic record of work carried out under supervision of Dr. Rana Pratap Yadav, Assistant Professor, Electronics and Communication Engineering Department, Thapar University, Patiala from January 2017 to July 2017. The matter presented in this this has not been submitted either in part or full to any other university or institute for the award of any other degree.

Date: ..... 14/07/2017 .....

*Malvika*  
Malvika  
(801563013)

It is certified that the above statement made by the candidate is correct to the best of my knowledge and belief.

Date: ..... 14/07/2017 .....

  
Dr. Rana Pratap Yadav  
(Assistant Professor, ECED)

## ACKNOWLEDGEMENT

First of all, I would like to express my gratitude to **Dr. Rana Pratap Yadav**, Electronics and Communication Engineering Department, Thapar University, Patiala for his patient guidance and support throughout this report. I am truly very fortunate to have the opportunity to work with him. I found his guidance to be extremely valuable.

I am also thankful to our Head of the Department, **Dr. Alpana Agarwal** as well as P.G. coordinator **Dr. Ashutosh Kumar Singh**, Associate Professor for providing me adequate environment in carrying the work and for the motivation and inspiration that triggered me for the work.

I would like to extend my gratitude to entire faculty and staff of Electronics and Communication Engineering Department who directly or indirectly helped me in the process and contributed towards this work. Also, I am greatly indebted to all my friends who constantly encouraged me.

At last but not the least my gratitude towards my parents, who always supported me in doing the things my way and whose everlasting desires, selfless sacrifice, encouragement, affectionate blessings and help made it possible for me to complete my degree

Malvika  
M.E. (801563013)

## ABSTRACT

The advancement in wireless communication system and increasing demand to make small size and multiband antenna applications has a great demand in both commercial as well military applications. To fulfill this demand, the fractal antenna has been introduced. The utilization of fractal geometries has a great impact in many areas of science and engineering. The development of an antenna by utilizing a fractal idea will reduce an antenna size without reducing its performance.

Wideband fractal antennas geometry has been proposed in this report. The design and development of Pythagorean Tree Monopole Fractal Antenna for frequency 3-8 GHz has been presented. In this design, the Pythagoras tree shaped fractal antenna is deliberated by using a unique idea known as Pythagorean tree which follows a Pythagoras theorem. Fractal is an idea which is being utilized in patch antenna to have improved characteristics over ordinary microstrip antenna. The fractal tree antenna is characterized by its self-similarity and space filling properties. The antenna is fed by microstrip line feeding. Several fractal geometries has been presented. The parametric study is done to observe the effect of different parameters like patch length, feed width, ground length etc. on the performance of an antenna. From the simulation results, it is clearly noted that the minimum return loss of -38.75 dB is achieved at the resonant frequency of 5.61 GHz which is a good result. Further, the antenna parameters like return loss, bandwidth, resonating frequency, directivity, gain and VSWR are calculated. The simulated results give the significant improvement in impedance bandwidth. The overall antenna design is simulated by using Software named CST 2014 Microwave Studio Suite.

## TABLE OF CONTENTS

Sr. No	Name of the Chapters	Page No
	<i>Declaration</i> .....	<i>ii</i>
	<i>Acknowledgement</i> .....	<i>iii</i>
	<i>Abstract</i> .....	<i>iv</i>
	<i>Table of contents</i> .....	<i>v</i>
	<i>List of Tables</i> .....	<i>viii</i>
	<i>List of Figures</i> .....	<i>ix</i>
	<i>List of Acronyms</i> .....	<i>x</i>
<i>Chapter 1</i>	Introduction.....	<i>1</i>
<i>1.1</i>	Preamble.....	<i>1</i>
<i>1.2</i>	Fractal Geometry.....	<i>2</i>
<i>1.3</i>	Development of Microstrip Fractal.....	<i>3</i>
	<i>1.3.1</i> Advantages and Disadvantages of Patch Antenna.....	<i>5</i>
<i>1.4</i>	Feed Techniques.....	<i>6</i>
	<i>1.4.1</i> Microstrip Line Feed.....	<i>7</i>
	<i>1.4.2</i> Co-axial Feed.....	<i>8</i>
	<i>1.4.3</i> Aperture Coupled Feed.....	<i>9</i>
	<i>1.4.4</i> Proximity coupled feed.....	<i>10</i>
	<i>1.4.5</i> Coplanar Waveguide Feed (CPW).....	<i>11</i>
<i>1.5</i>	Dimension Parameters.....	<i>12</i>
	<i>1.5.1</i> Length.....	<i>12</i>
	<i>1.5.2</i> Width.....	<i>13</i>
	<i>1.5.3</i> Extension of Length ( $\Delta L$ ).....	<i>13</i>
<i>1.6</i>	Fractal Shaped Antenna Elements .....	<i>13</i>
<i>1.7</i>	Features of Fractal Antenna.....	<i>15</i>
<i>1.8</i>	Advantages and Disadvantages.....	<i>16</i>
<i>1.9</i>	Applications of Fractal Engineering.....	<i>16</i>
<i>1.10</i>	Parameters for Measuring Antenna's Performance.....	<i>17</i>

1.10.1	Radiation Pattern.....	17
1.10.2	Directivity.....	17
1.10.3	Gain.....	18
1.10.4	Antenna Efficiency .....	18
1.10.5	Input Impedance.....	18
1.10.6	Bandwidth.....	19
1.10.7	Voltage Standing Wave Ratio (VSWR).....	19
1.10.8	Return Loss.....	20
1.10.9	Far-Field.....	20
1.10.10	Smith Chart.....	20
1.11	Work Covered In Thesis.....	21
1.12	Organization of Thesis.....	22
Chapter 2	Literature Survey	23
Chapter 3	Gap Analysis and Objectives	30
3.1	Gaps in Study .....	30
3.2	Objectives.....	30
Chapter 4	Design of Pythagoras Tree Shaped Monopole Fractal Antenna For Wireless Communications	31
4.1	Introduction.....	31
4.2	Generic Layout of Pythagoras Tree Shaped Fractal Antenna.....	31
4.3	Microstrip Line Feeding.....	32
4.4	Design Considerations for the Fractal Antennas.....	33
4.4.1	Selection of Substrate.....	33
4.4.2	Element length and width.....	34
4.4.3	Feed Point Location .....	34
4.5	Design Procedure of Pythagoras Tree Shaped Fractal Antenna Using Microstrip Line Feeding.....	34
4.6	Proposed Antenna Design.....	35
Chapter 5	Results and Conclusion	38
5.1	Introduction.....	38
5.2	Simulation Results.....	39
5.3	Conclusion.....	46
Chapter 6	Conclusion and Future Scope	48
6.1	Conclusion.....	48

6.2 Future Scope..... 48  
References..... 50

## LISTS OF TABLES

<b>Sr. No</b>	<b>Table Details</b>	<b>Page No</b>
<i>Table 1.1</i>	<i>Comparison of the characteristics for different feed techniques .....</i>	<i>12</i>
<i>Table 4.1</i>	<i>Design parameters of the proposed Tree Shaped Fractal Antenna</i>	<i>37</i>
<i>Table 5.1</i>	<i>Summary of the Antenna Parameters of Designed Antenna at 5.62 GHz frequency</i>	<i>47</i>

## LISTS OF FIGURES

<b>Sr. No</b>	<b>Figure Details</b>	<b>Page No</b>
Figure 1.1	Fractal Tree Geometry.....	3
Figure 1.2	Structure of microstrip patch antenna.....	4
Figure 1.3	Common shapes of microstrip patch elements.....	5
Figure 1.4	Microstrip line feed.....	7
Figure 1.5	Coaxial Probe feeding .....	8
Figure 1.6	Aperture-coupled feed.....	9
Figure 1.7	Proximity-coupled feed.....	10
Figure 1.8	Coplanar Waveguide feed.....	11
Figure 1.9	(a) and (b) some common examples of Fractal Geometries.....	14
Figure 4.1	Microstrip Line Feed .....	32
Figure 4.2	Illustration of the first three iterations for Pythagorean tree fractal...	37
Figure 5.1	Designed Structure of Tree shaped Fractal Antenna on CST 2014.....	39
Figure 5.2	Plot representing S11 of Pythagoras Tree monopole fractal antenna.	40
Figure 5.3	Simulated Return Loss	41
Figure 5.4	Directivity	42
	(a) Polar Plot .....	42
	(b) 3D Plot .....	42
Figure 5.5	Gain (a) Polar Plot.....	43
Figure 5.5	(b) 3D Plot.....	43
Figure 5.6	VSWR vs. Frequency Plot.....	44
Figure 5.7	Parametric Sweep on the ground length.....	45
Figure 5.8	Parametric Sweep on feed line width.....	46

## LIST OF ACRONYMS

<i>MPA</i>	<i>Microstrip Patch Antenna</i>
<i>CPW</i>	<i>Coplanar Waveguide Feed</i>
<i>MMIC</i>	<i>Microwave Monolithic Integrated Circuits</i>
<i>UWB</i>	<i>Ultra-Wide Band</i>
<i>VSWR</i>	<i>Voltage Standing Wave Ratio</i>
<i>RL</i>	<i>Return Loss</i>
<i>IFS</i>	<i>Iteration function system</i>
<i>MSL</i>	<i>Microstrip Line</i>
<i>RF</i>	<i>Radio Frequency</i>
<i>IPTFA</i>	<i>Iterated Pythagoras Tree Fractal Antennas</i>
<i>MPTF</i>	<i>Modified Pythagorean Tree Fractal</i>
<i>WLAN</i>	<i>Wireless Local Area Network</i>

# CHAPTER 1

## INTRODUCTION

---

### 1.1 PREAMBLE

The modern trends in telecommunication system and rapid advancement of wireless communication has urged the requirement for wide bandwidth antennas with much reduced dimensions than conventionally achievable. The prospective of these antenna is in their compact sizes. To demonstrate the promising applications in numerous fields, the antennas are of many types. The microstrip patch antenna is one of this type. Due to its paramount characteristics such as low profile, less expensive, easy to manufacture, light weight and simple to integrate with RF devices, the microstrip patch antenna (MPA) has captivated a wide attention. To attain the desired results, the investigation of several characteristics has been done. This has instigated the antenna research in various fields. The fractal shaped antennas are one of the kind. The concept 'Fractal' is the extension to the microstrip antenna. For shrinking the size of antenna, fractal geometries have been presented. This new design concept have been introduced for miniaturized design with broad band behaviour. A fractal is "a rough or fragmented geometric shape" and to accomplish this geometry one begin with an extremely basic pattern that grows through the applications of rules [2]. In many situations the procedure to make the figure grow from one stage to next is by taking the original figure and then modifying it or adding to it. The process can be repeated recursively an infinite number of times. The fractal geometries have been introduced for diminishing the dimensions of an antenna. There are two main features of fractal geometries: Self similar property and Space filling property. The outcome of self-similarity property of assured fractals is a multiband behaviour [3]. As a result of self-similarity in the geometry, there is an increase in the bandwidth of every single band. By means of space filling properties, the outcome is reduction in the size of an antenna. In other words, the utility of fractal structures help in attaining a single wide band acknowledgment. A fractal antenna can be utilized to receive and transmit over an extensive range of frequencies because it act as a multiband due to its self-similarity properties. The effective usage of an electrically thick substrate provide the improvement of narrow bandwidth in case of microstrip antenna. Currently, many fractal geometries have been presented for antenna applications with varying degrees of achievement in enhancing the attributes of an antenna. Some of these geometries have been particularly valuable in diminishing the size of an antenna, while other designs aim at incorporating multi-band

properties. However no noteworthy step has been taken in authenticating the fractal characteristics of these geometries with features of antenna. The research work displayed here is essentially for examining the geometrical feature of fractals that incredibly impact the response of an antennas utilizing them. In recent years there has been account of a few antenna configurations in era of fractal geometries [1-3]. These are termed as multifunctional due to their property of operating at multiple frequency bands; in addition to this, they are low profile in nature with moderate gain against their name. One method to compose a multiband antenna is by applying fractal shape into antenna geometry. In this work the Pythagoras tree monopole fractal antenna is presented for single frequency broad-bandwidth operations. This work demonstrates the special type of antenna utilizing Pythagoras method. The next step is to procure the mathematical expressions of the design equations for these antennas in order of its geometrical parameters such as the dimension of fractal. Before the introduction of status of literature on such antenna geometries, the description of fractal geometries is elucidated first in order to comprehend the performance of such antennas. The overall design is simulated by using the software CST 2014 Microwave Studio Suite.

## **1.2 Fractal Geometry**

The term ‘fractal’ was first discovered by the French mathematician B.B. Mandelbrot in 1970. It refers to broken or irregular fragments. A fractal is a geometrical shape that can be disintegrate into parts and each part is a reduced size duplicate of entire infinitely. The fractal trees are also known by the name of fractal canopies and Pythagoras trees [7]. The geometry of fractal is such that there is no distinguishing features that is size. The composition of each fractal is such that it consists of manifold iterations and that consists of single shape. In other words, the approach taken in this work for the procreation of trees here is to some extent dissimilar. The approach is such that we begin with a “stem” and then one of its end is permissible to branch off in two directions. Then, in the succeeding phase of iteration, all of these branches is permissible to branch off repeatedly, and then the same procedure is persist infinitely [7]. In the present study, the basic geometry undergoes two kind of generalizations; the first is that the angular separation of the branches is modified or fluctuated at every stage of iteration. In the second approach there is difference between the relative lengths of the branch in both the cases due to variation of length in one stage relative to the next as shown in Fig.1. It is always recommended to practice the use of only line segments in order to make the calculation of fractal properties convenient and this is applicable to all branches of the geometry. In many fields of science and engineering the fractal geometries is practiced; one of

which is antennas. These kind of geometries are used by the antennas for various communication applications. The use of fractal geometries have brought a lot of improvement in several antenna characteristics to varying extents. The fractal geometries has been taken into account for diminishing the size of antenna.

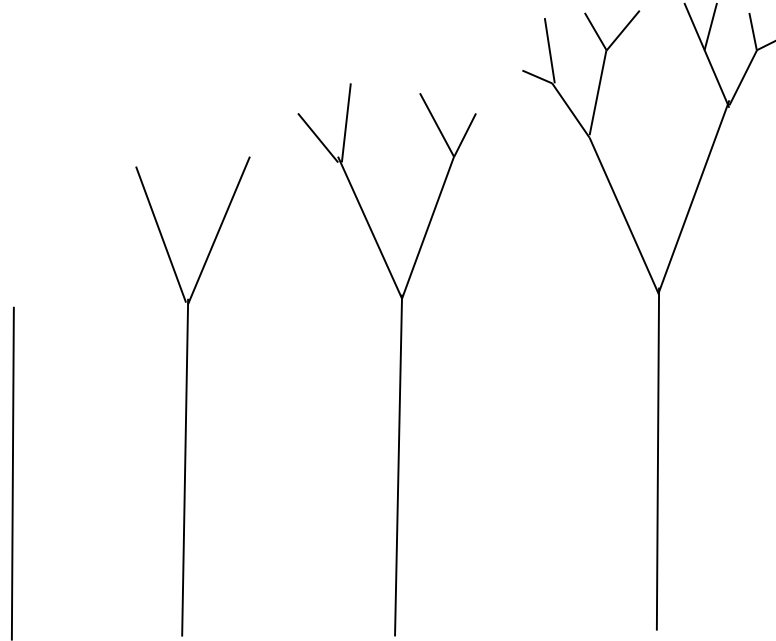

Figure 1.1 Fractal Tree Geometry

### **1.3 DEVELOPMENT OF MICROSTRIP FRACTAL**

The basic configuration of Microstrip Patch Antenna (MPA) includes a radiating patch on one side of a dielectric substrate and a ground plane on the opposite side as appeared in Figure 1.2. The base layer of dielectric substrate is entirely enclosed by conductors and appear as a ground plane. The patch can take any conceivable shape and is generally made of conducting material, for instance, copper or gold [13]. The transmitting patch and the feed lines are typically photograph carved on the dielectric substrate.

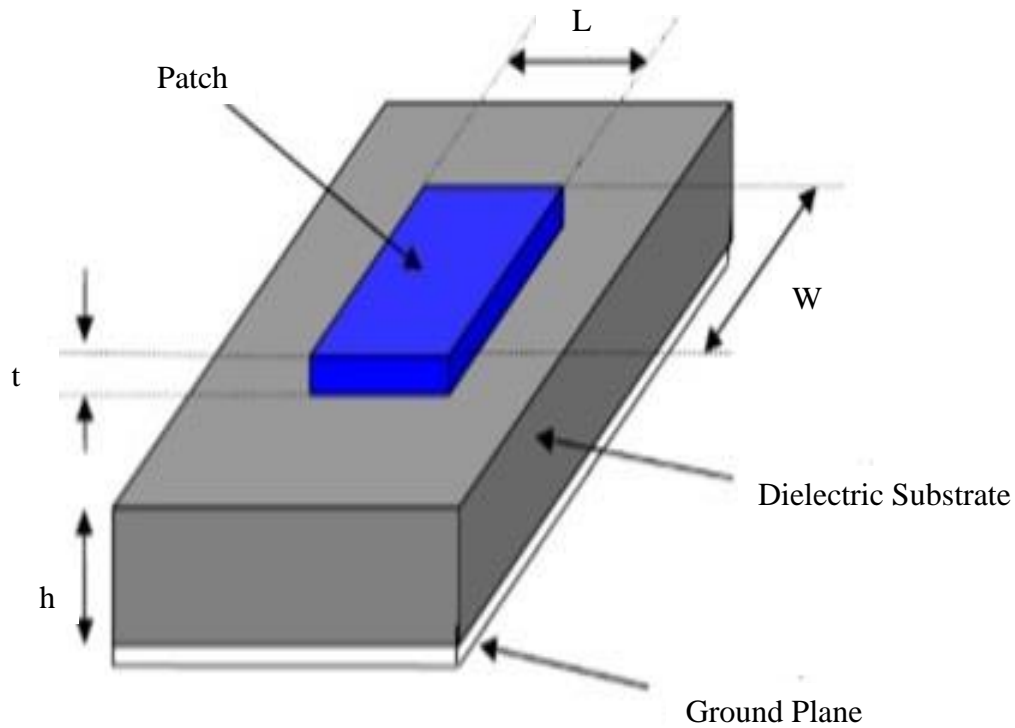

Figure 1.2 Structure of microstrip patch antenna [13]

In the figure,  $h$ = substrates thickness;  $t$ = patch thickness.

A microstrip antenna gets energized when it get attached to a microwave source. As a result of this, there is a dissemination of charge on the upper as well as the lower surfaces of the patch. Also, there is a distribution of charge on the surface of the ground plane. Then, the distribution of positive and negative charges arises. The patch is typically a square, rectangular, round, triangular and circular or some other basic shape as shown in Figure 1.3 so as to make the investigation and execution calculation simpler. For the rectangular patch, the patch is chosen to be very thin such the  $t \ll \lambda_0$ . Here 't' stands for patch thickness. The dimensions of the patch is such that the range of length  $L$  of the patch is i.e.  $0.3333 \lambda_0 < L < 0.5 \lambda_0$ . Here  $\lambda_0$  stands for the free-space wavelength. [13]. The height  $h$  of the dielectric substrate is generally  $0.003 \lambda_0 \leq h \leq 0.05 \lambda_0$ . The dielectric constant of the substrate is typically in the range  $2.2 \leq \epsilon_r \leq 12$ .

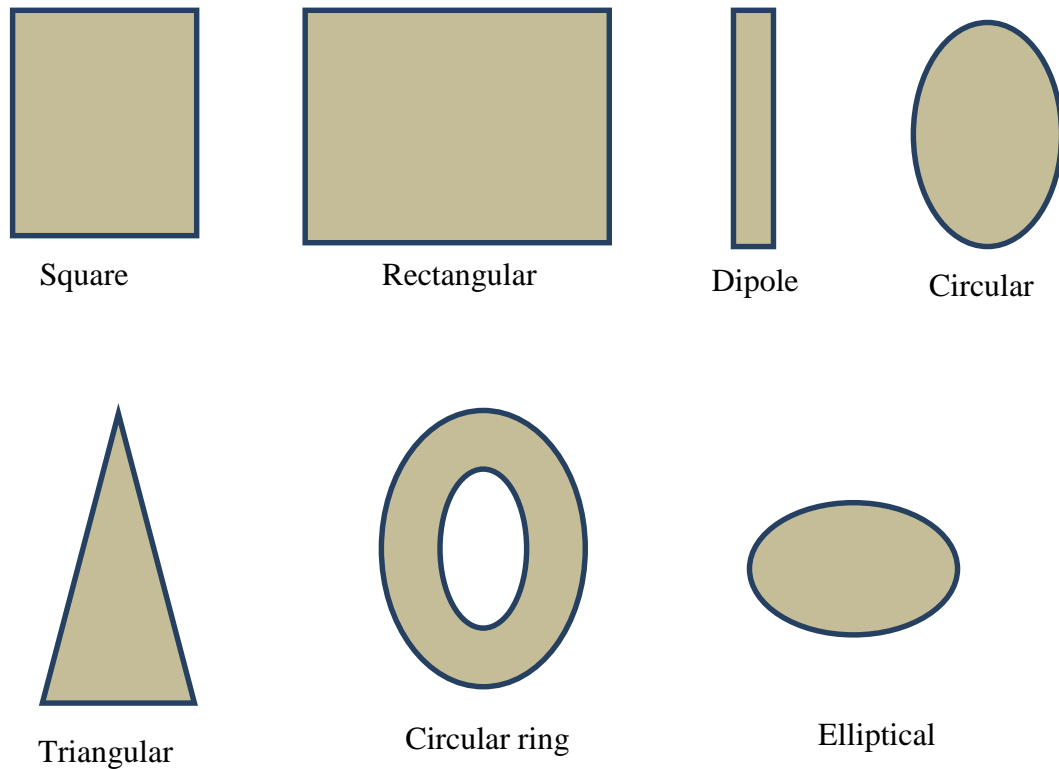

Figure 1.3 Common shapes of microstrip patch elements

Basically, the radiations in the microstrip patch antenna is the result of fringing fields that exists between the patch edge and the ground plane. To guarantee the great performance of the antenna, the utilization of thick dielectric substrate is consistently anticipated. Since, this is responsible for improved efficiency, improved radiation and higher bandwidth. Nevertheless, this type of configuration results in a larger size of antenna. The higher dielectric constants is the imperative to design a compact microstrip patch antenna. In any case, this is less efficient and furthermore results in narrow bandwidth. Consequently a compromise must be reached between antenna measurements and antenna performance [13].

### 1.3.1 Advantages and Disadvantages of Patch Antenna

Patch antennas include various advantages and additionally a few drawbacks. Some of them are listed below.

## **Advantages**

Microstrip antenna have high consideration in light of their great attributes as follows:

- Less bulky and small volume
- Low profile and a continuous planar configuration
- Less cost of fabrication, so easy to manufacture in enormous quantities.
- Supports both the polarization that is linear as well as circular.
- Easy to integrate with additional integrated circuits.

## **Disadvantages**

However there are several disadvantages of using microstrip antenna which are as follows:

- Bandwidth is precised
- Efficiency is less
- Gain is less in some cases
- Results in superfluous radiation from feeds and junctions
- Reduced end fire radiator with the exception of tapered slot antennas
- Power handling capacity is less.
- Excitation in surface wave is there.

## **1.4 FEED TECHNIQUES**

Feeding techniques plays a significant role in the designing of an antenna and to enable antenna arrangement to have a control at sufficient power of transmission. There are numerous arrangements that can be utilized to feed MPA. These techniques can be categorised into two types: contacting and non-contacting. In the contacting strategy, the RF power control is fed directly to the radiating patch by the utilization of interfacing component. In case of non-contacting scheme, so as to exchange the power between the microstrip line and the radiating patch, electromagnetic field coupling is done [13]. The five most popular feed techniques used are:

1. Microstrip Line feed
2. Coaxial Probe feed (both contacting schemes)
3. Aperture Coupled feed

#### 4. Proximity Coupled feed

#### 5. CPW feed (both non-contacting schemes)

##### 1.4.1 Microstrip line feed

The microstrip line feed is a conducting strip whose width is smaller in comparison to the width of patch. In this feeding method, a feed is coupled to the verge of microstrip patch as shown in Figure 1.4, So, this type of feeding technique is easy to design and match by just regulating the inset position. The smaller width of conducting strip in contrast with the microstrip patch has the preferred standpoint that the feed can be etched on a similar substrate. This results in the accomplishment of a planar structure. So as to match the impedance of the feed line to the patch without the requirement for any extra matching component, the inset cut is made in the patch. However, as the thickness of substrate increases results in increase in spurious feed radiation and surface waves which in practice, limit the bandwidth.

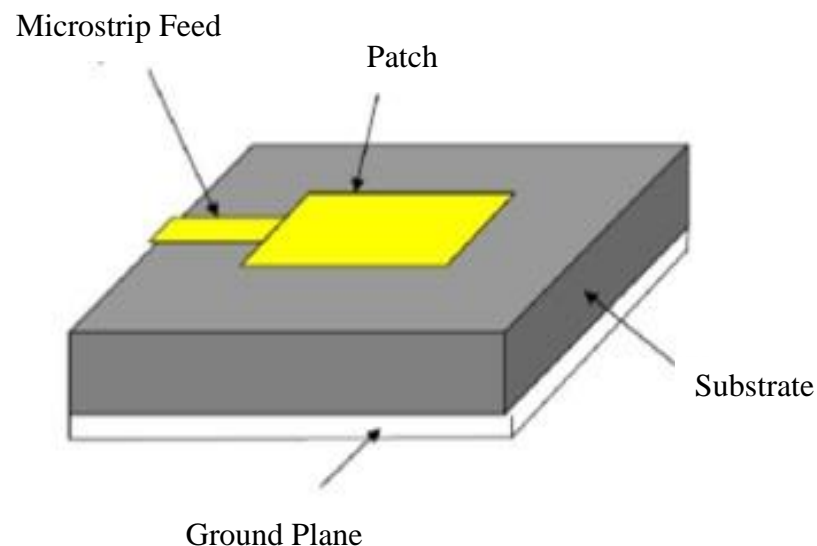

Figure 1.4 Microstrip line feed [13]

### 1.4.2 Coaxial feed

The outer conductor of the coaxial cable is connected to the ground plane and the inner conductor is stretched out up to the patch antenna as displayed in Figure 3.4 .This type of feeding technique is called coaxial feed technique. The fabrication and matching in case of coaxial feed is easy and also the spurious radiations are low in this case. However, the limitation is its narrow bandwidth and modelling is not easy particularly for thick substrates. To overcome these limitations, the aperture coupling feeds are introduced [13].

#### Advantages

- Fabrication is not difficult
- Matching is easy
- Spurious radiation are less

#### Disadvantages

- Results in narrow bandwidth
- Modelling is not easy especially in case of thick substrate as hole must be in the substrate and the connector juts outside the ground plane in this manner not making it totally planar for thicker substrate

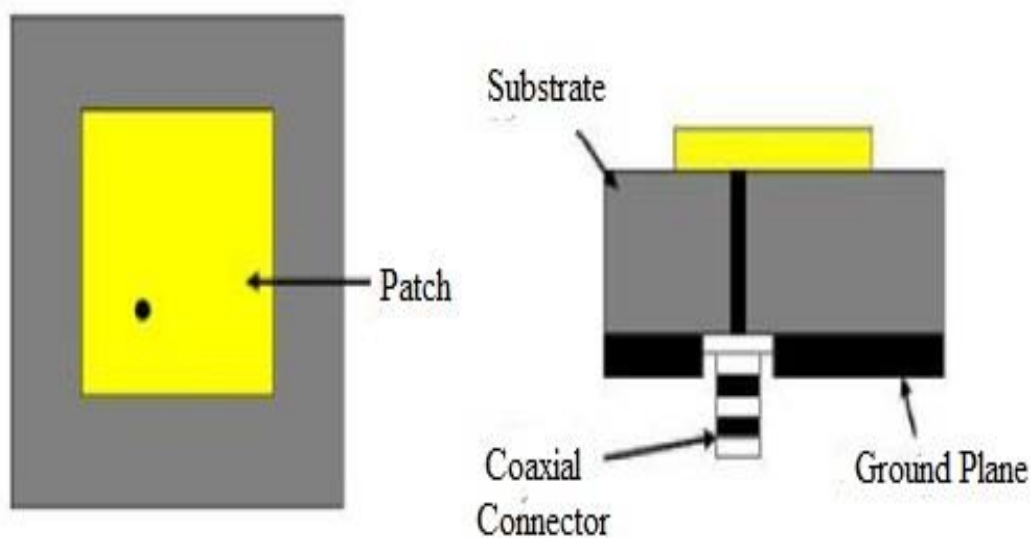

Figure 1.5 Coaxial Probe feeding [13]

### 1.4.3 Aperture coupled feed

The radiating patch and the microstrip feed line are isolated by the ground plane as appeared in Figure 1.6. This kind of feed arrangement is called Aperture coupled feed technique. The patch and the feed line is coupled through a aperture in the ground plane. Typically a lower substrate can be made with high dielectric constant material to yield tightly coupled feed that don't produce spurious radiation and upper substrate can be made with thick low dielectric constant material to produce loosely bound fringing fields that yield improved radiation[13].

#### **Advantages**

It analyses the feed mechanism and permit the independent optimization of its element.

#### **Disadvantage**

The major disadvantage is that fabrication is not easy owing to manifold layers. This in turn, also increases the thickness of an antenna. This arrangement of feeding is also responsible of narrow bandwidth [13].

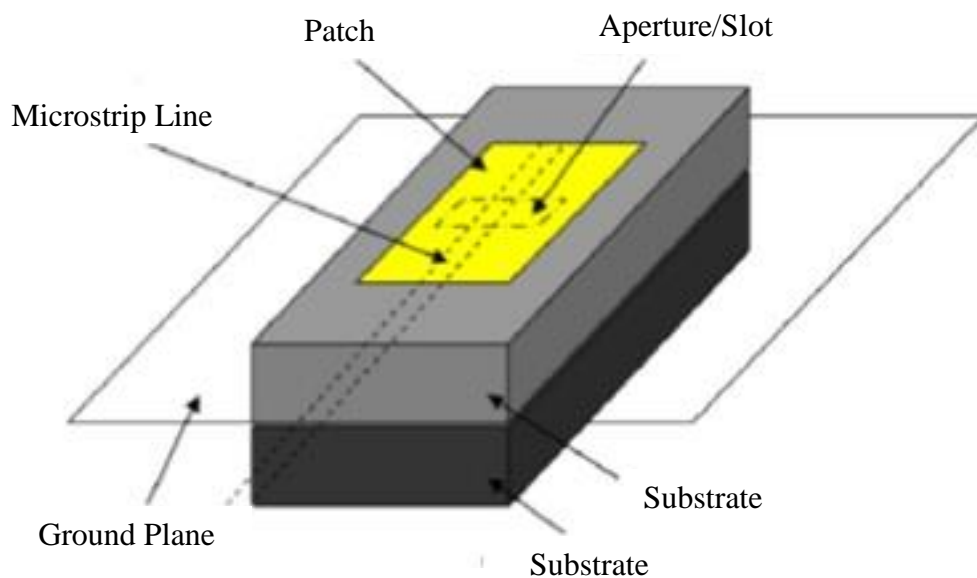

Figure 1.6 Aperture-coupled feed [13]

#### 1.4.4 Proximity coupled feed

This feeding method is termed by the electromagnetic coupling arrangement. Proximity coupled techniques also uses two substrates which are isolated by the feed line. The ground plane is placed below the lower substrate. From the Figure 1.7 it is clearly demonstrated that the two dielectric substrates are utilized and the arrangement is such that the feed line is inserted between the two substrates that is, the two substrates are separated by the feed line and the radiating patch lies over the upper substrate. In comparison to other type of feeding, the bandwidth is maximum in case of proximity coupled feed mechanism. In spite of this, there are some limitations that the fabrication of such a kind of feeding mechanisms is difficult. Also, because of multiple layers, the thickness of patch antenna increases. The improvement in this feeding technique is that it eradicates spurious feed radiation and this as a result provide high transmission capacity [29], because of total increment in the thickness of the MPA.

##### **Advantage**

- The bandwidth is largest in this case.
- It is simple to model.
- The spurious radiation are low and is difficult to fabricate.

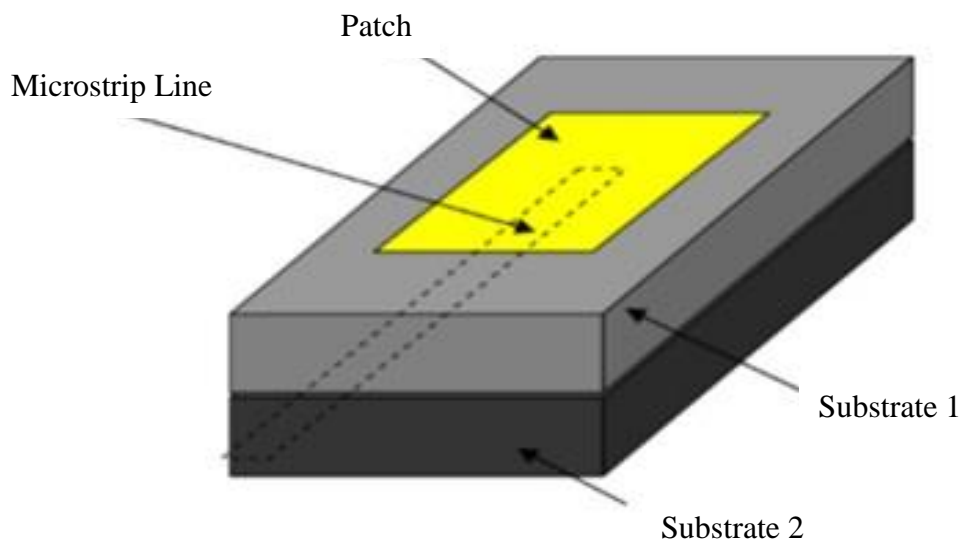

Figure 1.7 Proximity-coupled feed [13]

#### 1.4.5 Coplanar Waveguide Feed (CPW)

Coplanar waveguide is a kind of planar transmission line system comprising of a conductor strip in the centre and two ground planes are situated on either side of middle conductor and all lie in the same plane. A CPW is the preferably used for microwave integrated circuit (MMIC) design. It is always covered to feed the microstrip antenna with a CPW for integrating microstrip antennas with CPW due to the fact that both coplanar waveguide and microstrip have a planar geometry. The coplanar waveguide (CPW) fed antenna have been extensively utilized for wireless communication features, for example, wide data transfer capacity, no soldering points, single metallic layer results in easiest structure, simple integration with MMICs and so forth [13].

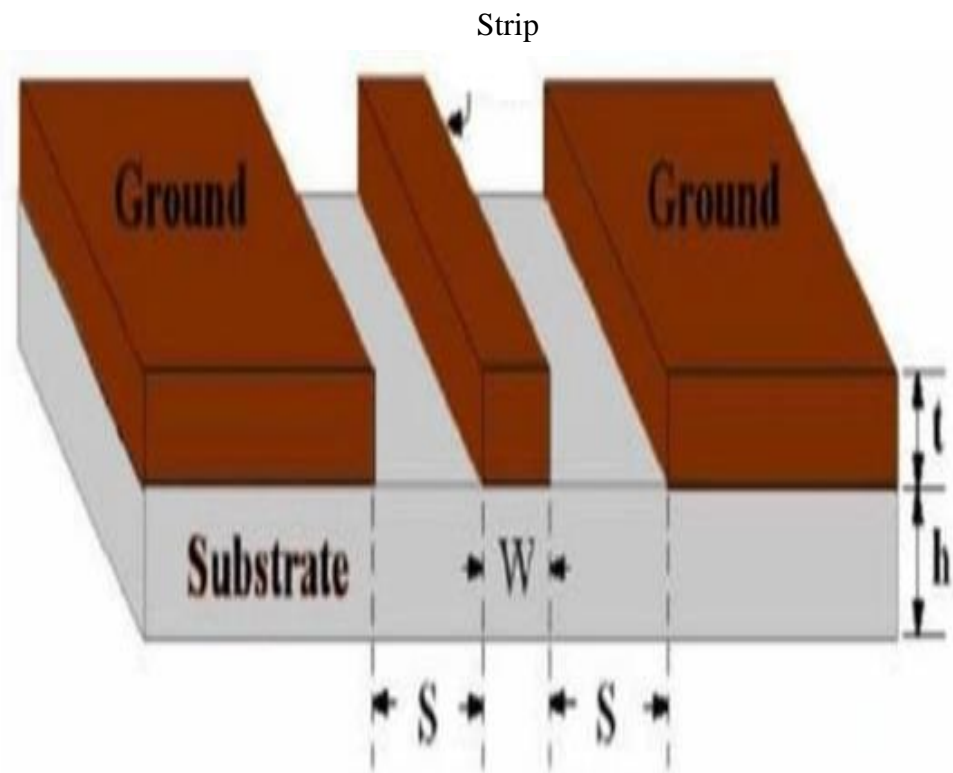

Figure 1.8 Coplanar Waveguide feed [13]

Characteristics	Microstrip Line Feed	Coaxial Feed	Aperture Coupled Feed	Proximity Coupled Feed
Spurious feed Radiation	Greater	Greater	Lesser	Minimum
Reliability	Better	Reduced caused by Soldering	Good	Good
Impedance	Not difficult	Not difficult	Not difficult	Not difficult
Bandwidth (attained with impedance matching)	2- 5%	2-5%	2-5%	2-5%

Table 1.1 Comparison of the characteristics for various feeding methods

## 1.5 DIMENSION PARAMETERS

The performance of microstrip antenna depends upon patch dimensions i.e. Length (L), width (W) which are calculated by using the reference equations given below:

### 1.5.1 Length

The length of the patch antenna is also referred to as the resonate length. It defines the reverberate frequency and its esteem is  $\lambda/2$  for a rectangular patch in its fundamental mode.

The length is given by the formulae as [29]

$$L \approx 0.49 \lambda_d = 0.49 \frac{\lambda_0}{\epsilon_r} \quad (1.1)$$

$\lambda_0$  = Wavelength of free space

$L$  = Resonant length

### 1.5.2 Width

The dimensions of the rectangular patch antenna have a special effects in the simulation outcomes, particularly length (L) and the width (W) of patch. The width is given by the formulae as [29]

$$\text{Width} = \frac{c}{2f_r} \sqrt{\frac{2}{\epsilon_r + 1}} \quad (1.2)$$

$c$  = Speed of light

$f_r$  = the resonant frequency which is equal to 1 GHz

### 1.5.3 Extension of Length ( $\Delta L$ )

The extension of the length is calculated by a precise general formula for the normalized case. The extension of length is calculated as: [29]

$$\Delta L = 0.412h \frac{[\epsilon_{reff} + 0.3]^{[W/h + 0.264]}}{[\epsilon_{reff} - 0.258]^{[W/h + 0.8]}} \quad (1.3)$$

$h$  =height

$w$  = width

$\epsilon_{reff}$  = Effective dielectric constant

## 1.6 FRACTAL SHAPED ANTENNA ELEMETS

The different fractal geometries has been taken into consideration by antenna designers in many areas. However, with the deep understanding of antennas using them numerous geometrical and antenna characteristics have been inter-linked. This progress in the development of new kind of an antenna known as fractal shaped antenna. This demand is fulfilled by Dr. Nathan Cohen. Cohen had experimentally attempted the utility of many geometries of fractal. Such curves like Von Koch curves, Sierpinski gasket, Murkowski curves and fractal tree are among them. The first fractal antenna was built by Dr. Nathan Cohen in 1988. There are numerous fractal geometries [7] that proves essential in developing new and imaginative designs for antennas. Figure 1.9(a) and (b) below show some of these unique geometries. These geometries incorporate immense number of tips and corners with the desire to improve the efficiency of an antenna.

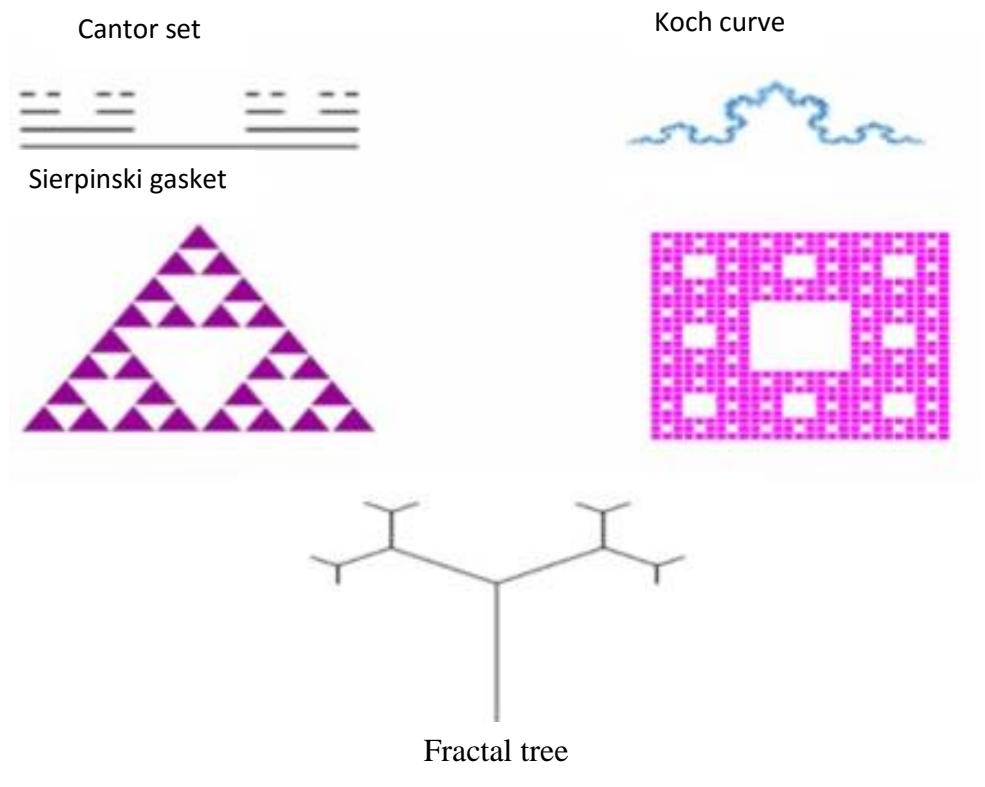
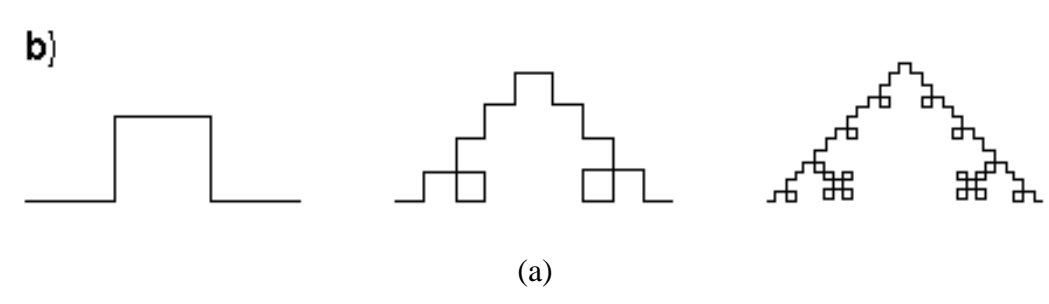
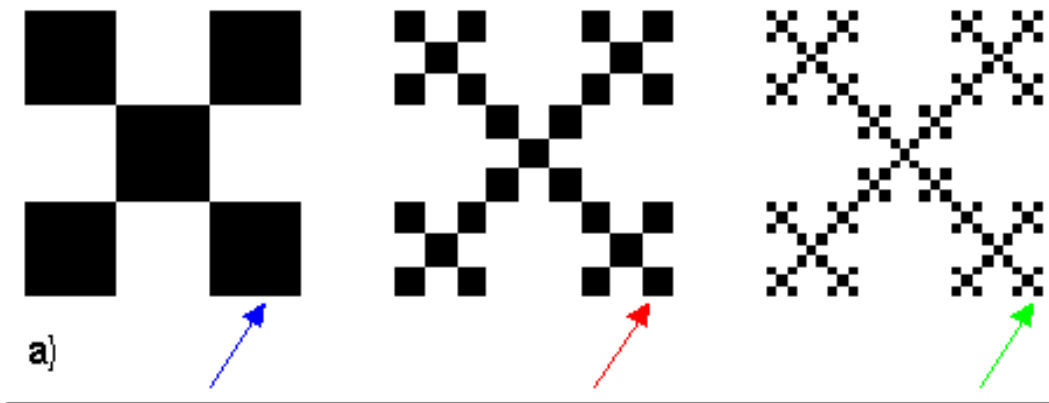

(b)

Figure 1.9 (a) and (b) some common examples of Fractal Geometries [7]

These fractals offers many benefits when applied in order to bring advancement in several antenna elements.

By employing fractals geometry to antenna elements:

- An antenna of compact size can be designed
- Attain resonance frequencies that are multiband.
- Provide optimization in gain.
- Successful in attaining wideband frequency band.

Most fractals have infinite complexity and detail that can be used to reduce antenna size and develop low profile antennas. For most fractals, self-similarity concept can achieve multiple frequency bands because of different parts of the antenna are similar to each other at different scales. The combination of infinite complexity and self- similarity makes it possible to design antennas with various wideband performances.

The requisite of the fractal antenna is due to the following facts:

- The intrinsic properties of fractal geometry of an antenna provide us with broadband and multiband frequency response
- These geometries are responsible for compact size in contrast to an antennas with conventional designs compared to antennas of conventional designs, despite the fact that it maintain good to excellent efficiencies and gains.
- These geometries offers robustness and mechanical simplicity. The features of the fractal antenna are attained owing to its geometry and not by the accumulation of discrete components.
- Design to specific multi frequency attributes encompassing specified stop bands and in addition specific multiple pass bands.

## **1.7 FEATURES OF FRACTAL ANTENNA**

As earlier, it was stated that the fractal antennas utilize the concept of fractal geometry for their enterprise. The basic aim for the introduction of fractal geometries is to achieve reduction in the effective aperture of an antenna.

Fractal Geometries have the following unique features:

- (i) Self-similarity feature is valuable in designing multiband antenna
- (ii) Compact size by the mechanism of iteration

- (iii) Enhancement in the number of iterations improves the electrical length of antenna
- (iv) Space filling feature is important to scale down the antenna size.

To achieve the miniaturization, improvement in input matching ability and multiband and wideband characteristics, one can take advantage of these properties to design antenna.

## **1.8 ADVANTAGES AND DISADVANTAGES**

The fractals has the following advantages:

- Small cross- sectional area
- Better input impedance
- Wideband/multiband
- Frequency independent (consistency in performance over a huge range of frequency).  
For such a reason, a fractal antenna is treated to be the independent of frequency.
- Diminished mutual coupling in array of fractal antennas

Inspite of many advantages of utilizing fractals, there are a few limitations related with it as well. They are as per the following:

- Complexity involves in the design and fabrication process
- Numerical limitation has to be taken care of.
- Gain loss is there in some cases
- Practically few iterations are possible

In order to overcome these limitations, further research and new advances in this field might be proven helpful.

## **1.9 APPLICATIONS OF FRACTAL ENGINEERING**

From the time when the fractals were invented by mathematician Benoit Mandelbrot, they have set up widespread applications in a number of branches of science and engineering. The extension of antenna design concepts beyond the Euclidean geometry is basic motivation of fractal antenna engineering. One of the field of engineering that has contributed much from the applications of fractals is Fracture mechanics. Several inventive applications have emerged due to the space filling property of fractal geometries. The generation of fractal mesh has

contributed to reduce the requirement of memory and CPU time for definite element exploration of vibration issues [22]. The study has been made extensively in the mechanisms of diffraction from the fractal screens and scattering of electromagnetic waves. The dual band nature of the frequency response results from the self-similarity property of the fractal geometry. The evolution of these fractal antenna arrays and fractal shaped element occurred in 1990's.

## **1.10 PARAMETERS FOR MEASURING ANTENNA'S PERFORMANCE**

For depicting the performance of an antenna, different parameters should be discussed first. There are numerous parameters which are used to analyse in order to examine the effective functioning of antenna. These parameters are cited from the IEEE Standard Definitions of Terms for antennas [1].

### 1.10.1 Radiation Pattern

The radiation pattern or antenna pattern is the graphical representation of the radiation properties of the antenna as a function of space coordinates. Radiation pattern is determined in the far-field region. It is represented as a function of directional coordinates. The Radiation properties include power flux density, radiation intensity, field strength, directivity, phase or polarization. The antenna radiation pattern is defined for large distance from the antenna where the angular distribution of the radiated power does not depend upon the distance from the radiation source is independent on the power flow direction, that is, it is the same when the antenna is used to transmit or when it is used to receive radio waves.

### 1.10.2 Directivity

The directivity of an antenna is a dimensionless quantity and is defined as the ratio of the radiation intensity in a given direction from the antenna to the radiation intensity averaged over all directions. The average radiation intensity is equal to the total power radiated by the antenna divided by  $4\pi$ .

$$D = 4\pi U/P_{rad}. \quad (1.4)$$

### 1.10.3 Antenna Gain

The Gain of the antenna is another significant parameter for portraying the performance of an antenna. Gain refers to the direction of maximum radiation. It is closely related to the directivity. It is characterized as the proportion of intensity, in a given direction, to the radiation intensity that would be acquired if the power acknowledged by the antenna were radiated isotropically.

$$G = 4\pi U/P_{in}. \quad (1.5)$$

### 1.10.4 Antenna Efficiency

The total antenna efficiency is used to take into account losses at the input terminals and within the structure of the antenna. Basically, the antenna efficiency is defined as the ratio of gain to directivity. In the event that the efficiency of the antenna is 100% at that point gain is said to be same as directivity.

$$\eta = G/D. \quad (1.6)$$

### 1.10.5 Input Impedance

Input Impedance is characterized as the impedance introduced by an antenna at its terminals. It can likewise be characterized as the proportion of the voltage to current at a pair of terminals or the proportion of appropriate components of the electric to magnetic fields at a point. The input impedance of an antenna is generally a function of a frequency. It depends upon many components including its geometry, its technique for excitation and its vicinity to surrounding objects. It is important to take note of that for maximum power transfer, the input impedance of an antenna should be matched to the impedance of the transmission line. On the off chance if the matching is not achieved, the echoed wave originated at the antenna terminal will revert in the direction of the energy source. This cause a decrease in overall efficiency of a system as a result of reflection of energy.

Input impedance is composed of real and complex parts and is written in general form as: [1]

$$Z_{in} = R_{in} +j X_{in} \quad (1.7)$$

Where  $R$  denotes the resistive part of the impedance. Also known as power radiating component of the impedance

$X$  denotes the reactive portion of the impedance. Also known as power storage portion of the impedance.

#### 1.10.6 Bandwidth

Bandwidth describes the frequency range over which the antenna can properly radiate or receive energy. Bandwidth is one of the determining parameter used to decide upon an antenna. The bandwidth of an antenna is the frequency range over which antenna give design performance that is, gain, efficiency, return loss etc.

#### 1.10.7 Voltage Standing Wave Ratio (VSWR)

The Voltage Standing Wave Ratio (VSWR) is defined as a measure impedance match or mis-match between the antenna and the characteristic impedance of a transmission. There are two special cases of VSWR, 1:1 and  $\infty$ :1. A ratio of 1:1 is indicator that the load is perfectly matched to the transmission line whereas a ratio  $\infty$ :1 is the indicator of worst case. In order to measure and examine VSWR, the most common case is when the transmitting antennas are installed and tuned. It is likewise parameter that outline the matching property of a transmitting antenna For the most maximum energy transfer to happen from the feed line to the antenna, the impedance of feed line must match exactly to the characteristic impedance of the antenna, during the time when a connection between the transmitter and an antenna is made is by a feed line. In case, the impedances of an antenna and feed line do not match, then the result is that a portion of the electrical energy cannot be passed on from the feed line to the antenna. Thus, the energy which is not exchanged to an antenna is reverberated back towards the transmitter. This causes standing wave pattern because of the communication of these reflected waves with forward waves. The mechanism of matching the impedance of the antenna to the feed line impedance is usually done by making the use of an antenna tuner [15]. Preferably, the range of VSWR must lie between 1-2. VSWR is also defined in terms of reflection coefficient that is it describes how much power is reflected from the antenna. The expression for VSWR in terms of reflection coefficient  $\Gamma$ , is defined as follow: [1]

$$VSWR = \frac{1 + |\Gamma|}{1 - |\Gamma|} \quad (1.8)$$

- The achievable estimations of VSWR are from 1 to  $\infty$
- If VSWR=1, then it is said to be perfectly matched and  
If VSWR= $\infty$ , then it is said to be completely unmatched.

#### 1.10.8 Return Loss

The return loss (RL) is the parameter which indicates the amount of power that is lost to the load and does not return as a reflection. Waves are reflected leading to the formation of standing waves, when the transmitter and antenna impedance do not match [15]. In other words, the RL is the parameter that is similar to VSWR to indicate how well the matching between the transmitter and the antenna has taken place. The RL is defined as:

$$\text{Return Loss (RL)} = -20 \log_{10} |\Gamma| \quad (1.9)$$

Where  $\Gamma$  is the reflection coefficient

- Possible values of return loss are from 0 dB to  $\infty$  dB.
- Return Loss is always a positive number.

#### 1.10.9 Far- Field

Far-field determines the antenna's radiation pattern. The usefulness of radiation pattern is for rapidly calculating the practicality of antenna for a specific application. Far-field region is defined as the region in which the spatial distribution of radiated power is not influenced by the distance. This region of far-field is dominated by the radiating fields, where both E- fields and H- fields are orthogonal to each other.

#### 1.10.10 Smith Chart

The Smith Chart, originally developed by Phillip Smith, is a useful tool for envisioning the impedance of transmission line and antenna impedance as a function of frequency. Smith chart is a graphical plot of the normalized resistance and reactance functions in the complex reflection-coefficient plane. It is also an extremely

a useful tool in impedance matching circuit design. The two dimensional complex reflection coefficient plane is used to plot the smith chart. The smith chart is calibrated in both normalized impedance and normalized admittance. In order to distinguish between them different colours are used. These are frequently perceived as the Z, Y and YZ Smith Charts accordingly. The Smith Chart can be utilized for complications that includes any characteristic impedance by methods for normalized scaling, despite the fact that the most frequently used is 50 ohms.

## **1.11 WORK COVERED IN THESIS**

In this existing telecommunication system, the most prevailing situation is the prerequisite of an antennas with miniature dimensions and much wider bandwidth. In order to fulfill the above requirement, that is, to design the miniature size antennas, the new journey of progress and innovation pushes the researchers to initiate the research on antenna in wide-ranging direction. The fractal antenna is one of them. The fractal concept was acknowledged by French mathematician Benoit Mandelbrot in 1975. The fractal geometry is such a type that provide us the characteristics like multiband behavior, space filling and self-similarity properties and most predominantly, it depreciate the antenna size. The fractal is a theory which is the extension to the microstrip antenna. To improve the characteristics of an antenna with varied degree of realization, innumerable geometrical structures have been proposed. The effect of fractals on the dimensions of an antenna is that it will broaden the bandwidth and results in shrunken in the parameter measurements of an antenna. The fractal antenna exploits the fractal geometries for designing the antenna by using the concept of Iteration function system (IFS). The fractals have the characteristic that it will enrich the aggregate electrical length of the antenna without undergoing any change in the total area. An interesting fact about fractal antennas are that they achieve the multiband or broadband performance without requiring any need of the matching components. So the use of fractal antenna simplifies the circuit design.

In this thesis work the above mentioned qualities are utilized to design the fractal antenna known as Pythagoras Tree Shaped Fractal Antenna for single frequency broad bandwidth operations. The design of Pythagorean tree shaped fractal antenna is considered by incorporating the exclusive idea recognized as Pythagorean tree. The utilization of fractals give us a greater set of parameters to obtain the attributes of an antenna. The proposed antenna operates over the frequency band 3 GHz – 8 GHz for  $VSWR < 2$  and find its applications in WiFi/WLAN, WiMAX and satellite mobile communication. The antenna is simulated by

using the software CST 2014 Microwave Studio Suite. Based on the simulation results, On the basis of simulation results, the outcome of antenna proposed is good miniaturization and less bulky.

## **1.12 ORGANIZATION OF THESIS**

**Chapter 1:** In the first part the general idea of the work done is given. It covers the introduction about the Fractal Antennas and explained its applications. It additionally covers different types of fractal antenna available. Also, this section shows the fundamental theory of fractals depicting its components and distinctive fractal geometries. Their parameters that are used to judge the antenna performance such as return loss, gain, far- field radiation and VSWR and an overview of work is done in thesis.

**Chapter 2:** This chapter presents the Literature Review in context to Pythagoras Tree Shaped Fractal Antenna. The Literature Review examines some of the relevant facets of fractal theory, potential technologies for physical construction and reviews the concept behind applying fractal theory to antenna research.

**Chapter 3:** This chapter covers the Gap Analysis, thesis objective and methodology of Pythagoras Tree Shaped Monopole Fractal Antenna.

**Chapter 4:** This chapter illustrates the design and analysis of Pythagorean Tree Shaped Monopole Fractal Antenna for wireless communication. Its discussion of design procedure is presented in this chapter. This antenna is analyzed by means of CST microwave studio.

**Chapter 5:** This part covers the simulation and results of Pythagorean Tree Shaped Monopole Fractal Antenna. Simulation is done by utilizing CST microwave studio and the outcomes are presented.

**Chapter 6:** This chapter concludes the work done. It contains conclusion and extent of future scope.

## CHAPTER 2

### LITERATURE SURVEY

---

With a specific end goal to start the project, the initial step is to study the research papers that have been performed earlier by other researchers. The papers that are associated to this title are chosen and studied. With the help of this literature review, it gives more clear understanding to perform this report.

**Janakiraje S. Bhosale** *et al.* [10] exhibited the outline of a 2 GHz novel tree formed fractal antenna based on fractal tree geometry. The intention is to present the idea of fractals and to utilize it in antenna arrays for getting the multiband behavior. In this paper, two sustaining strategies that is probe and microstrip feeding have been discussed. The comparative investigation of various configurations of feeding strategies demonstrates that microstrip gives a data transmission of around 16%. That is, there is increment in the data transmission upto 16% with little abatement in gain. Likewise the results simulated demonstrates the critical change in VSWR. Additionally, the multi-band resonating frequencies are accomplished from microstrip feeding system.

**Sujeet Kumar Yadav** *et al.* [27] demonstrated a fractal patch antenna, in which a one of a kind fractal geometry is utilized known as Pythagoras tree geometry. The feed technique used in the design is microstrip line (MSL) feeding technique. That is, a planar Iterated Pythagoras tree Fractal antennas (IPTFA) with microstrip line feed are researched and investigated. The improvement in the multiband behaviour of the antenna designed is examined with  $VSWR < 2$ . The antenna is designed with a frequency ranging from 1.12 GHz to 5.93 GHz. This finds the applications in WLAN, Wi-Max & satellite mobile communication. Also in this paper, it is shown that with increase in iterations, the number of resonant frequency band increases.

**Arvind Kumar** *et al.* [4] displayed the outline and examination of a planar multiband radio wire with impedance ventures in the base way. This is a planar Iterated Pythagorean fractal tree receiving wire (IPTFA) which is two dimensional planar reception apparatus, developed by squares. The realization of the impedance steps is done by restricted ground plane. This guarantees enhanced impedance matching, data transmission attributes and multiband in contrast with non-iterated shape. As the number of iterations increments new reverberation

recurrence will get, the antenna designed has conservative size of  $41.08 \times 41.08 \times 1.57 \text{mm}^3$ . It works over the recurrence band of 2.4 GHz with VSWR  $< 2$ .

**Sanjay V Khobragade** *et al.* [7] presents a repetitive multi-band or log- periodic behavior by taking into account a fractal antennas. This has been credited to the self-comparative and space filling properties of the antenna's geometry. This can be used to scale down reception apparatuses. These interesting properties of fractals is helpful to build up another class of receiving wire component plans to have a few exceedingly attractive properties, including multiband execution, low side flap level. In this paper, fractal tree receiving wire is composed which depends on ternary fractal tree geometry for remote neighborhood .The antenna design is proposed to operate over the frequency band of 2.4 GHz. The feed technique used in the design is coaxial probe fed method. This antenna offers the omnidirectional property and operate in 2.1GHz-2.8GHz frequency band.

**Devesh Kumar** *et al.* [18] presented a Pythagoras tree shaped multiband fractal antenna. This paper depicts the special kind of reception apparatus which utilizes the Pythagoras procedure. In this system each iterations takes after going before emphasis following Pythagoras geometry with contiguous squares. The idea of fractal radio wire helps in planning multiband antenna. The antenna parameters like return loss, directivity, Voltage Standing Wave Ratio and radiation pattern has been examined. The radio wire planned presentations multi-band conduct. It is shown that there is increase in the working frequency bands with increase in the number of iterations.

**Suresh Sahni** *et al.* [6] portrays the plan and simulation of a one of a kind sort of fractal patch radio wire, known as Pythagorean tree monopole fractal reception apparatus. The feeding strategy utilized as a part of the proposed configuration is a micro strip line feed. The receiving wire utilizes a truncated ground plane and the design was simulated utilizing CST simulation software. The proposed radio wire works over the recurrence band in the vicinity of 5.34 and 5.75 GHz for VSWR  $< 2$ . The improvement in terms of directive gain and data transmission has been accomplished. It is analyzed that it is ideal to select an optimized feed width, its position and ground length so that the VSWR and impedance are within the acknowledged levels.

**Kulbir Singh** *et al.* [26] introduce the concept of the fractals. The one of a kind of fractals have been manipulated to build up another class of receiving wire component designs that are multi-

band and smaller in measure including multi-band performance of the antenna outlined. Additionally, give an examination and implementation of quickly developing field of fractal antenna designing including late advancements. The simulation results demonstrates that expanding the fractal measurement of the radio wire prompts a higher level of scaling down.

**Jagtar Singh Sivia** *et al.* [25] designed a multiband fractal geometry based rectangular microstrip patch antenna at the frequency range of 1-10 GHz. The substrate material used for the design of proposed antenna is FR4 substrate with the thickness of 1.58mm. The excitation to the antenna is provided by microstrip feed line technique. The proposed antenna resonates at twelve distinct frequencies as 1.86, 2.33, 3.67, 4.57, 5.08, 6.06, 7.03, 7.75, 8.08, 8.84, 9.56 and 10 GHz and the return losses are - 15.39, - 16.48, - 10.02, - 17.29, - 13.15, - 23.41, - 10.22, - 11.28, 17.02, - 10.94, - 15.15 and - 15.48 dB individually. The simulation results shows that the directivity of the antenna resonates at 2.5GHz.

**Renu Sharma** *et al.* [8] designed Pythagorean tree shaped fractal antenna. The design is implemented by using a distinctive idea recognized as Pythagorean tree that follows distinctive idea known as a Pythagoras theorem. The proposed antenna operates over the frequency ranging from 0-6 GHz. The base patch of the antenna proposed has the dimension of  $41.34 \times 41.34 \text{mm}^2$  and the height is of 1.6mm. The feeding technique used in the design is microstrip feeding technique. Tested results reveals that the antenna designed provide us with the improved results, that is multiband behavior is achieved along with  $VSWR < 2$ . Further, the modified design provides that more bands will be generated as the number of fractal iterations increases. As an outcome of space filling property, help in attaining the impedance matching. So the analyzed results shows that in order to obtain multi-frequency and wider bandwidth Pythagorean tree shaped idea is better in comparison to any other modifications.

**K.J. Vino** *et al.* [9] attained the estimated design equations for dipole antennas by examining the fractal nature of the geometry and by making the use of Hilbert curve geometry. Also a study has been made that the dimension of fractal can be conglomerated by varying the indentation angle in case of Koch curves. So as a result the resonant frequencies are in a close relation with the dimensions of fractal. Also, a parametric study has been made by fluctuating the branching angle in which the angle  $2\Theta$  is varied from  $30^\circ$  to  $180^\circ$  in steps of  $30^\circ$ . Because of the existence of abnormalities in the length ratio between the stem and branches at every stage of iterations, the characteristics of an antenna are also determined. So the analyzed results shows that there is a change in the dimension of fractal as a result of this variation .The results

prove that by changing geometrical features of fractal antenna there will only be variation in the multiband properties that affect their similarity dimension.

**Hyo-Won Song** *et al.* [24] examined a novel tree-molded ultra-wideband antenna for UWB applications. With a specific end goal to accomplish a ultra-wideband impedance matching, the halfway ground plane system and the fractal idea have been considered. The antenna is designed to operate over the frequency range 3.1-4.8 GHz. The examined results shows about demonstrates that great radiation attributes in the working recurrence have been accomplished. Also, the prototypes of the antennas designed have been successfully achieved. This optimized design of antenna is tested where the results shows as the consequence of increment in the quantity of iteration, the lower-edge of the impedance transfer speed is moved to the low recurrence. Moreover there is a change in the level of the impedance coordinating over the working frequency band 3.1-4.8GHz. Additionally the tested outcomes uncovers that the got radiation designs are near those of the ordinary dipole receiving wire.

**Dr.V.R.Anitha and Malli yuva sindhu** [22] exhibited the contemporary state of fractal tree antenna by incorporating the utilization of PIN diode switches in the geometry of fractal tree antenna for multiband applications. The antenna designed make the use of rectangular and triangular patches and is designed for three iterations. The antenna is in tree shape. The feeding technique used in the proposed structure is probe feeding. And it also make the use of the design to trigger one passage of antenna for requisite application regardless of the fact that the remaining parts of proposed antenna is not functioning. The antenna designed operate over the frequency bands such as 2.4-2.48 GHz that is for WLAN and 3.4 to 3.8 GHz that is for WiMax .The operating frequency is between 2.4GHz to 3.8GHz.

**Javad Pourahmadaza** *et al.* [12] initially proposed a novel modified microstrip-fed ultra wideband (UWB) Pythagorean tree fractal monopole reception apparatus over the frequency band in the vicinity of 2.6 and 11.12 GHz for  $VSWR < 2$ . With a specific end goal to accomplish a significantly more extensive impedance data transfer capacity and new resonances a modified Pythagorean tree fractal is presented in the customary T-fix. With the objective to achieve the new resonances, the number of tree fractal iterations were increased. The antenna is of compact size and has a dimension of  $25*25*1mm^3$ . By incorporating the possibility of multi-fractal in modified Pythagorean tree fractal (MPTF) radio wire configuration give the flexibility in monopole antennas regarding controlling resonances and transmission capacity. The analyzed results shows that a satisfactory impedance matching can be attained as the number of MPTF

iterations increases and by optimizing the parameters of antenna with appropriate values. This outcomes because of the space filling property of fractals. The proposed design of UWB Pythagorean tree fractal monopole antenna that is authorized to wireless communication also presents good performance as it provides improvement in bandwidth that operates over a frequency range 3.1-10.6 GHz.

**Douglas H. Werner and Suman Gangul** [3] presented the comprehensive study of the research area that is fractal reception apparatus engineering which incorporates the plan approaches for fractal radio wire components, frequency specific surfaces with fractal screen components and usage of fractals to the outline of antenna arrays.

**A. Aggarwal and M. V. Kartikeyan** [20] exhibited a fractal patch antenna utilizing Pythagoras tree as the fractal geometry for acquiring the double recurrence far reaching data transfer capacity operation. The antenna is intended to work on 2.4GHz and 3.5GHz WiMAX band with the goal to accomplish ultra wide bandwidth applications. The proposed antenna is energized with co-planer waveguide (CPW) feeding strategy. The antenna was simulated utilizing CST Microwave Studio. The created configuration has 25.532% impedance transmission capacity in the first band and 33.545% impedance transfer capacity in the second band as for center frequencies of 2.35GHz and 3.54GHz individually. A receiving wire configuration is simulated, investigated and created. The fabricated results demonstrates that the antenna acknowledges beyond 20% impedance data transfer capacity at both the recurrence groups which shows the expansive transmission capacity physical appearance at both the recurrence groups, that was unattainable utilizing ordinary rectangular patch geometry. The utilization of Pythagoras tree shaped fractal geometry gives the multi-recurrence and all inclusive transfer speed operation of the receiving wire without fusing any further of U or L spaces. The analyzed results shows that the deliberate gain up is 1–2dB not as much as the simulated antenna gain, that is because of the creation and estimation errors.

**Dethalia Ankitkumar Manjibhai et al.** [15] examined various types of fractal geometries in order to deal with all the optimal features of an antenna and to achieve the antenna characteristics that is, small size, low profile and multiband or broad band. The analyzed results shows that we can decrease the span of antenna and additionally show signs of improvement execution by fractal antenna engineering.

**Nemanja Poprže and Mico Gacanovi** [23] employed the technique of fractals to describe the concepts and techniques for shrinking the size of an antenna. Various kind of fractal geometries have been consolidated into the design of an antenna. The antenna design has incorporated several variations of fractal geometries.

**E. E. C. de Oliveira et al.** [13] investigated that fractal elements result in the overall size reduction. The proposed design make use of Koch curve fractal contours with the aim to achieve microstrip patch antennas miniaturization. The feed technique used in the proposed design is inset-fed technique. The outcomes additionally demonstrate that the utilization of inset-fed procedure viably permits a magnificent impedance matching of the fractal antenna utilizing a recessed microstrip-line feed. The Koch curve fractal was utilized with the goal to lessen the span of inset-fed patch reception apparatuses. The analyzed outcomes demonstrates that by utilizing the fractals shapes that is connected in an inset-fed patch radio wire permits a significant lessening of its general size, which brings about a total decrease of up to 39%, along these lines permitting its scaling down. However, there is a greatest disadvantage that lessening in measure created a diminishment in the data transmission, which is not desired

**Huseyin Altun et al.** [16] analyzed the reconfigurable detail of the fractal tree antenna geometry controlled by PIN diodes. The concept utilized in the design of antenna is that fractal tree antenna is fed from its center by a 50 ohms round coax. The proposed antenna validates reconfigurable over the frequency band ranging from 1.51GHz up to 8.6GHz. The examination of antenna is finished by utilizing CST Microwave Studio software. The different dimensional parameters such as on radiation pattern, operational frequency and directivity has been analyzed and investigated by regulating the PIN diode switches.

**D. H. Werner et al.** [17] investigated the frequency independent features of self- similar fractal antenna geometry. This has been incorporated to acquire the improvement of a multiband straight cluster configuration approach for which the directive gain is a log-periodic capacity of frequency.

**Shruti R.S Parmar and Er. Hardeep Singh** [30] presents the concept of fractal antenna and its different types of geometries that can be used to design an antenna. In this paper, the merits and the demerits of fractal antenna is also specified including the applications that are very useful in the research areas and other related fields. It has been revealed that the triangular

shaped reception apparatus has additionally working frequency and data transfer capacity in contrast with the other fractal shapes

**Saloni Upadhyay Lalit Jain** [33] investigated a fractal geometry based Sierpinski square monopole antenna for ultra-wide bandwidth (UWB) application with band-notched features. The antenna is intended to work over the frequency band 3.1-10.6 GHz. The tested results reveals that the measured radiation patterns are constant all over the operating band. The antenna designed achieve the gain 2-5dB and that too in ultra-wide bandwidth (UWB) frequency range. It has also been concluded that the gain of an antenna decreases in band rejection frequency.

**Amanpreet Kaur and Gursimranjit singh** [34] investigated an exhaustive analysis of recent improvements in the field of fractal antenna engineering alongside its design and calculations. The conclusion has been done that as the fractal iterations increases, the resonant frequency likewise builds which brings about lessening in the return loss. Finally, it has been concluded that the bandwidth and operating frequency of triangular shaped fractal antenna is more than other fractal shape antennas.

**Anirban Karmakar, Utsab Banerjee, Rowdra Ghatak, DR Poddar** [44] presents the design and examination of a planar expansive band monopole antenna by merging the likelihood of impedance steps and fractal spaces in the ground plane, that adds to the ultra-wide band features. Here the likelihood of impedance steps and fractal system is gotten the chance to enhance the antenna data trade capacity. The antenna proposed works over the frequency of 2.7 GHz to 10.9 GHz. Tested outcomes uncovers that the operation over this frequency gives 120% bandwidth which is near to ultra-wide transmission capacity specification.

## **CHAPTER 3**

### **GAPS ANALYSIS AND OBJECTIVES**

---

#### **3.1 GAPS IN STUDY**

- In the recent years, a considerable amount of work has been done to scrutinize the reduction in size of an antenna without decreasing the performance of antennas, in quest of its application in wireless systems.
- In this existing telecommunication system, the most prevailing situation is the prerequisite of an antennas with miniature dimensions and much wider bandwidth. With a specific end goal to satisfy the above requirement the research in different directions has been started, one of which is by utilizing different geometries of fractal shaped antenna element.

#### **3.2 OBJECTIVE**

This thesis describe the design and simulation of Pythagoras tree monopole fractal antenna for wideband, 3-8 GHz frequency range to achieve low profile and ease of integration. The utilization of fractals geometry contribute us with a greater set of constraints that incorporates in controlling the characteristics of an antenna. The design is implemented such as to shrink the physical antenna size and to enhance the impedance bandwidth. The simulation of fractal antenna should be possible for much iteration until the point that the coveted outcome is accomplished, they are multiband antenna. The behavior and properties of these antennas are investigated. The applications incorporate Mobile and satellite communication application, WiFi/WLAN, WiMax, Global Positioning System applications, Radar Application and so on.

# CHAPTER 4

## DESIGN OF PYTHAGOREAN TREE SHAPED MONOPOLE FRACTAL ANTENNA FOR WIRELESS COMMUNICATIONS

---

### 4.1 INTRODUCTION

In this chapter, the general procedure for designing a Pythagoras tree shaped fractal antenna has been presented. The fractal is the effective technique to improve the multiband behavior, easy to implement for patch antenna and most importantly, able to keep the profile of the antenna as low as possible. The Pythagoras fractal geometry is the plane geometry composed from squares. The fundamental shape is looked over the microstrip square patch antenna. The antenna geometry is named after a Greek mathematician Pythagoras, because of the fact that the sides of each triples of touching squares together shape a Pythagoras triplet. This in turn confines a right angle triangle. This is illustrated as a conventional method which is used to characterize the Pythagorean Theorem. The antenna is feed by the microstrip line feeding. The structure is designed and simulated using CST software. The design of the antenna has been undertaken in three major steps: In the first phase the fractal antenna is designed using CST studio 2014. Antenna is simulated and optimized using CST to justify the parameters used for the design. In the final phase, the best results that are achieved from the second step is used in order to incorporate the fractal geometry into the design.

### 4.2 GENERIC LAYOUT OF PYTHAGORAS TREE SHAPED FRACTAL ANTENNA

The basic procedure for designing tree shaped fractal antenna is illustrated in steps in a flow diagram as follow:

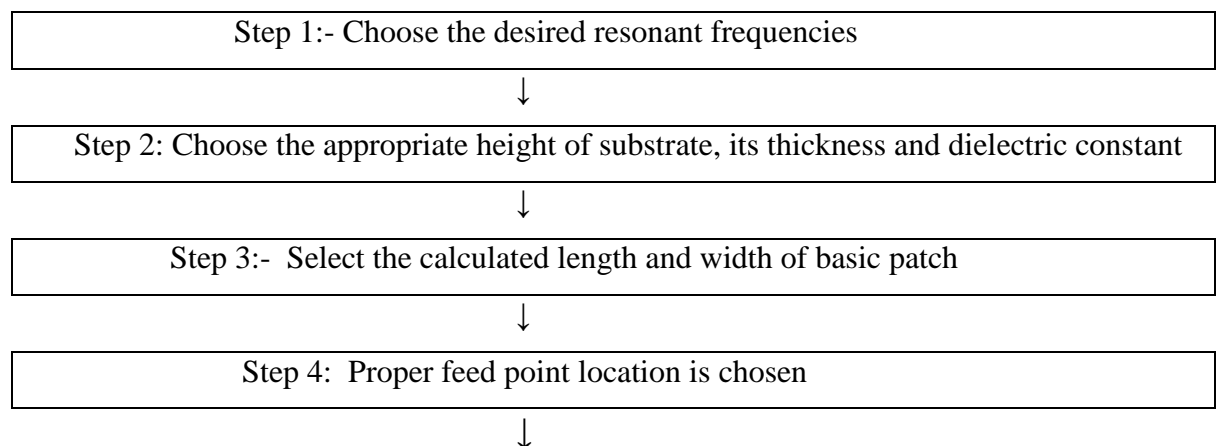

Step 5:- Simulation is done by using CST 2014 software



Step 6:- The simulated results are then optimized by changing the effective aperture of antenna which in turn improves the gain of antenna



Step 7:- The best outcome is chosen to design antenna to resonate at desired frequency

### 4.3 MICROSTRIP LINE FEEDING

As shown in figure, there is a direct connection of the conducting strip to the edge of microstrip antenna patch. In this type of feeding technique, it is to be noticed that the conducting strip is to be smaller in width in contrast with the patch. The biggest advantage of this kind of feed arrangement called microstrip line feeding is that it is conceivable to etch the feed upon a similar substrate that incorporates in providing a planar structure. The explanation behind inset cutis to accomplish the impedance matching between the feed line and patch input impedance without the requisite for any extra matching component.

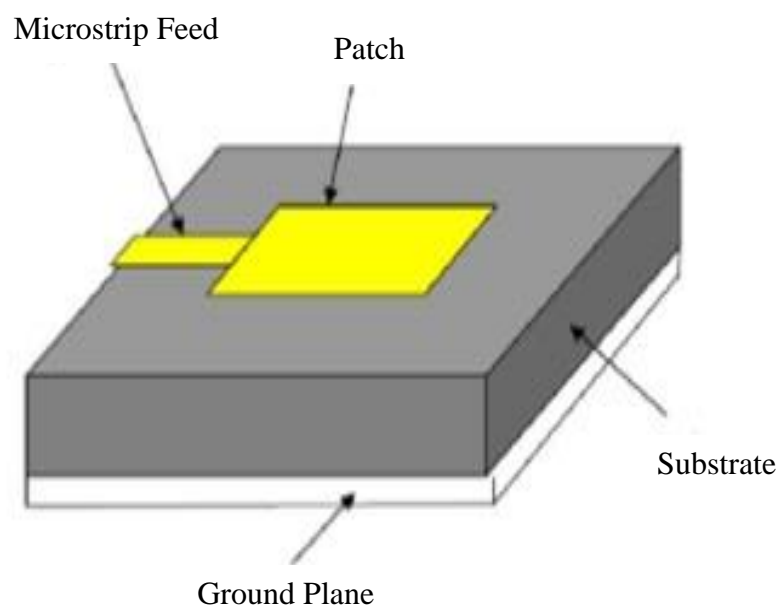

Figure 4.1 Microstrip Line Feed [29]

## 4.4 DESIGN CONSIDERATIONS FOR THE FRACTAL ANTENNAS

The patch antenna is composed on the premise of the detailing of length, width of fractal for a given dielectric constant and resonant frequency of the antenna. Usually, the comprehensive objective of the design is to accomplish the highly appropriate properties which includes low or negligible power wastage in side lobes, multi-band performance and minimization in the size of antenna. That is, the idea of fractal is to significantly diminish the size of an antenna without disintegrating the antenna performance. In the event that a microstrip antenna pattern can achieve this general target, at that point the first choice is the decision of appropriate antenna geometry. We are being provided with a substantial set of parameters by the use of fractal antenna which in turn control the antenna characteristics. The design procedure of a fractal antenna is illustrated in the succeeding subsection.

### 4.4.1 Selection of Substrate

The first step in the design procedure is to select the suitable dielectric substrate of appropriate thickness  $h_s$  and loss tangent. To design the antenna, the selection of proper substrate thickness is an important task. It is always recommended to choose a thick substrate. The reason behind is, that a thick substrate, apart from being mechanically robust, also offers enhancement in the radiated power, improvement in impedance bandwidth and reduction in conductor loss. Apart from this, it will likewise bring about the rise in the weight, surface wave loss, dielectric loss and supplementary radiations from the probe feed. In other words, the increase in thickness of the substrate directly affects the fringing fields which also as a result increases. Due to this the resonant frequency of the antenna decreases. While the performance parameters improves significantly such as gain, impedance bandwidth and return loss. The dielectric constant of the substrate  $\epsilon_r$  play a role analogous to that of substrate thickness. Any increase in the dielectric constant results in decrease in both the resonant frequency as well as the bandwidth. This results in the narrowband of the antenna system. The fringing fields residing at the patch periphery increases as the value of dielectric constant  $\epsilon_r$  is lowered and thus the power radiated from an antenna. Therefore, the substrate with  $\epsilon_r = 4.4$  are preferred. Here, the proposed antenna is built on Rogers RT/duroid 5880 PCB substrate of thickness  $h_s = 1.57$  mm and dielectric constant  $\epsilon_r = 2.2$  and the size of board is  $188 \times 146 \text{ mm}^2$ . The antenna is fed with microstrip line feeding.

#### 4.4.2 Element length and width

A design procedure is defined on the basis of simplified formulation which lead to simplified design of fractal antennas. The procedure described infers that the specified information includes the resonant frequency ( $f_0$ ), dielectric constant of the substrate ( $\epsilon_r$ ) and the substrate height  $h_s$ . Here, in terms of dimensions of the basic structure, L indicates the length and W indicates the width. Since the basic structure is of square patch, therefore the facet of length and width is identical i.e.  $L = W$ . So the total length of the basic patch is  $2L$  mm.

#### 4.4.3 Feed Point Location

The next task after the selection of dimensions of patch, that is L and W, is to determine the feed point in order to achieve a satisfactory impedance match that exists between the generator impedance and the input impedance of the patch element. It is to be noted that any modification in the position of feed results in alteration in return loss which in turn contributes to the easiest approach for impedance matching. In the microstrip line feeding, the feed can be etched on the same substrate in order to cater a planar geometry.

### **4.5 DESIGN PROCEDURE OF PYTHAGORAS TREE SHAPED FRACTAL ANTENNA USING MICROSTRIP LINE FEEDING**

The Pythagorean tree is a planar geometry assembled from the squares. Here the initial segment, i.e. generator, is not a square anymore but it is a rectangle. Hence we refer to it as a tree. The concept used in this type of geometry is that each of the square that is constructed on the initial segment i.e. rectangle is reduced by the factor of  $1/\sqrt{2}$ . For further iterations, the equivalent procedure is imitated recursively. It is important to note the angle between the contiguous squares. In other words, the initial segment is branched by a scale factor, then the next step involves that it is moved at an angle and at last, it is positioned at the top of the initial segment. So, in order to construct the tree of any order the identical pattern has to be followed.

To obtain the first iteration, we have to create a fractal structure from its basic structure by applying the Pythagoras theorem to compute the two sides of right angled triangle. This in turn, form the facet of each of two corresponding scaled down squares touching the vertices of basic square patch. Here, in this design we have used an isosceles right angled triangle in which each

flare angle is of 45 degrees. In this structure, the value of L is 42 mm. So in order to compute the length of sides of right angled triangle i.e.  $L_1$ , we will apply the Pythagoras theorem that is.  $\sqrt{L_1^2 + L_1^2} = L$  to it. We have to repeat the same principle in the second and third iterations to calculate the dimensions of  $L_2$  and  $L_3$  respectively.

If n = number of iteration

Number of squares in each iterations =  $2^n$

Total number of square patch structures after 'n' iterations =  $(2^{n+1} - 1)$

Dimensions of patch reduced after n iteration  $[1/\sqrt{2}]^n$

Dimensions of the structure after 'n' number of iterations =  $[(L+1) * (L/2+1)]$

The underlying patch is chosen from microstrip rectangular patch antenna that operates over the frequency range between 3 and 8 GHz for  $VSWR < 2$ . The feeding technique used is microstrip feeding. The feed line has the dimensions of length 11 mm and width 3 mm.

Using above relations in our proposed Pythagorean tree shaped fractal antenna we found out the results that, the basic patch is having the dimensions of  $L * L \text{ mm}^2$  and the squares are further repeated onto the basic patch and every iteration is scaling down the size of square of the factor of  $(1/\sqrt{2})$ . Finally, after the third iteration the structure was having the dimensions of  $4L * 3L \text{ mm}^2$  and further, the size of square is reduced by the factor of  $(1/2\sqrt{2})$ .

#### 4.6 PROPOSED ANTENNA DESIGN

We have calculated the parameters required for creating a fractal structure from equations described in section 4.5. The proposed antenna comprises of a patch component fixed on a dielectric isotropic layer over a truncated ground plane of length of 9mm. The width of ground plane is same as that of the isotropic layer. The substrate is made of material Rogers RT/duroid 5880 PCB. The substrate is made of material having a dielectric constant ( $\epsilon_r$ ) is 2.2 that is sufficient enough with a loss tangent of 0.0009. This substrate is promptly accessible, low cost and provide ease of fabrication for prototype designs. This is the reason it is preferable over the other substrate. The measurements of board is  $188 * 180 \text{ mm}^2$ . The thickness of the substrate is 1.57mm. The antenna designed is fed with microstrip line feed to accomplish the best outcomes in regard to the performance parameters of antenna.

Figure 4.2 demonstrates the detailed structure of Pythagoras fractal antenna after its final proposed iteration stage. The basic iteration square is of length  $L=42\text{mm}$ , first iteration square is of length  $L_1=29.698\text{mm}$ , second iteration square is of length  $L_2=21\text{mm}$  and the last iteration square is of length  $L_3=14.849\text{mm}$ . Presently, the one bigger and one smaller consecutive patch is kept steady at an angle of 45 degrees. Thus, the measurements of all the smaller patches will rely upon their immediate bigger neighbor patch. The width of the microstrip line feed is  $W_f=2.391\text{mm}$ . The gap between the ground plane and the patch is 2mm. The design parameters are depicted in Table 4.1. Initial three iterations with a basic patch designed manually as a microstrip patches are shown:

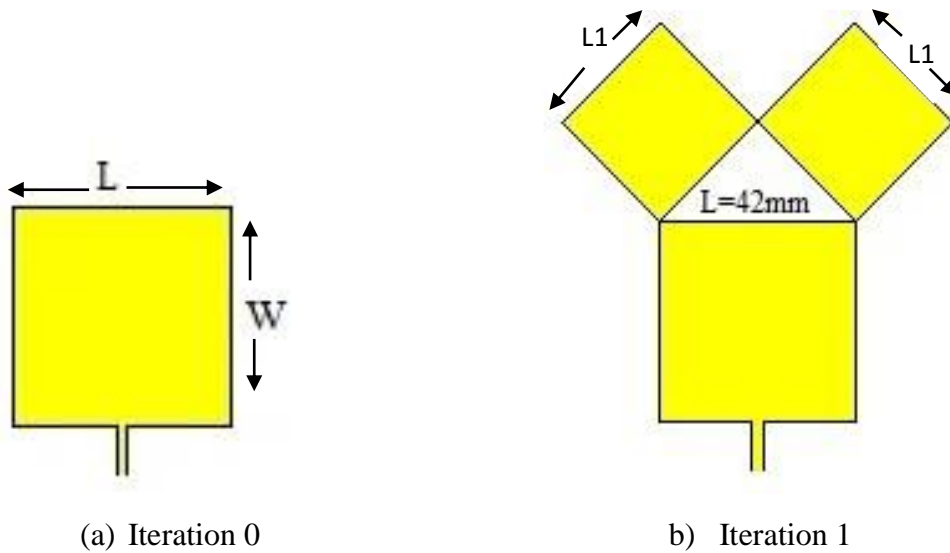

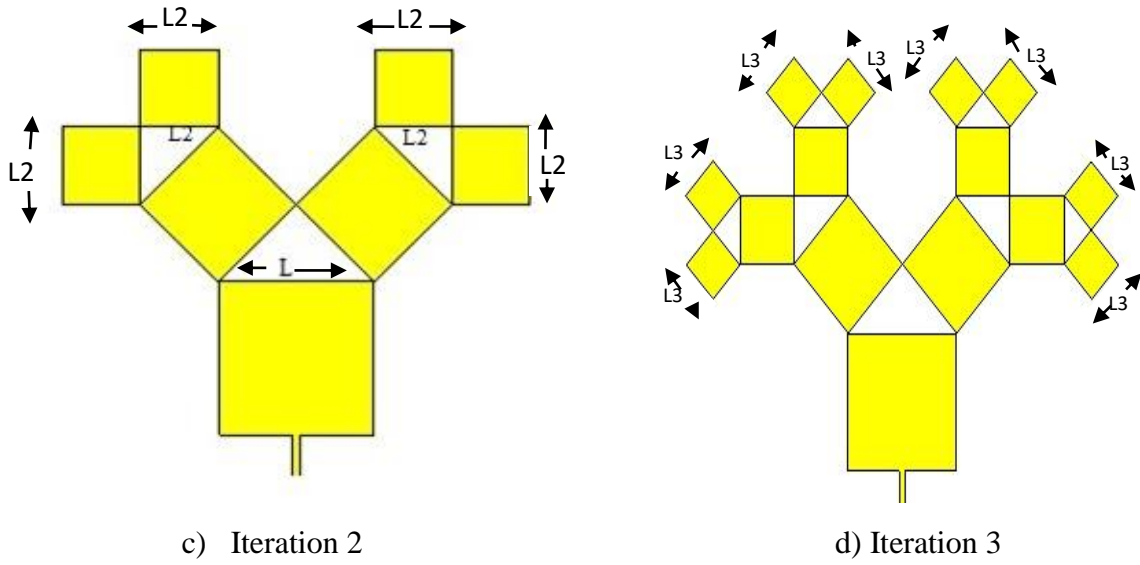

Figure 4.2 Illustration of the first three iterations for Pythagorean tree fractal

Variable	Values
L	42mm
L1	29.698mm
L2	21mm
L3	14.849mm
Substrate Thickness, $h_s$	1.57mm
Substrate Dimensions	188*180mm <sup>2</sup>
Substrate Used	Rogers RT 5880
Substrate Dielectric Constant, $\epsilon_r$	2.2
Loss Tangent	0.0009
Width of Feed Line, $W_f$	2.391
Flare angle	45 degrees

Table 4.1 Design parameters of the proposed Tree Shaped Fractal Antenna

# CHAPTER 5

## RESULTS AND DISCUSSIONS

---

### 5.1 INTRODUCTION

The entire model is designed and simulated using CST Microwave Studio software. The performance characteristics of proposed antenna such as return loss, gain, VSWR, directivity, impedance bandwidth and radiation pattern are analyzed and concluded. The simulated antenna design using CST 2014 studio is given in the Figures below:

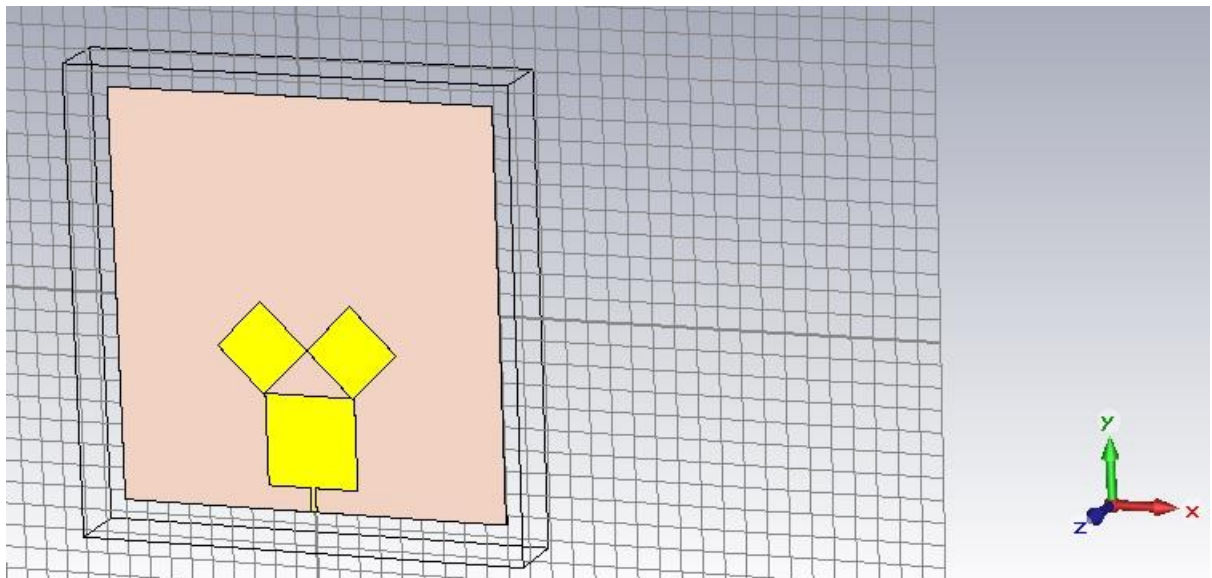

(a) Iteration 1

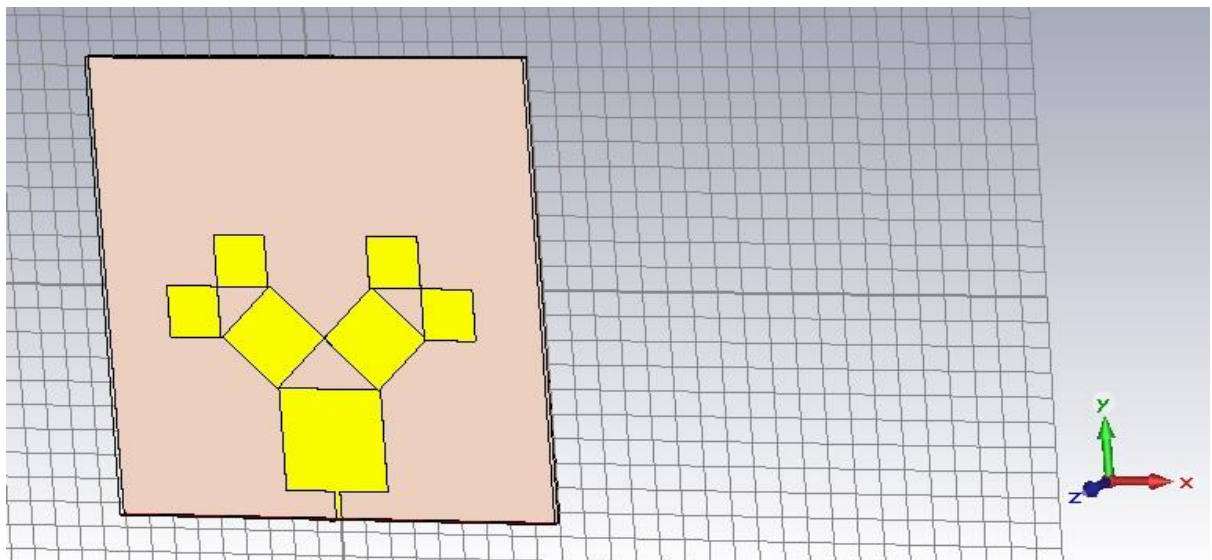

(b) Iteration 2

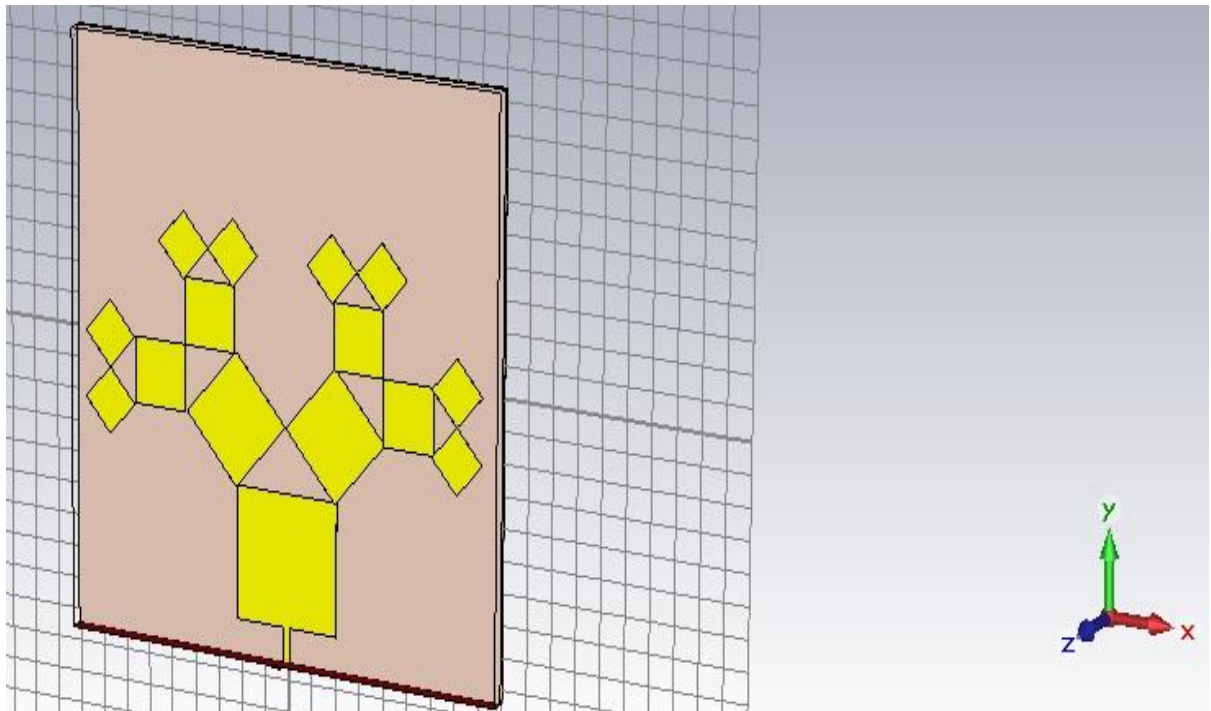

c) Iteration 3

Figure 5.1 Designed Structure of Tree shaped Fractal Antenna on CST 2014

## 5.2 SIMULATION RESULTS

### 1. Return Loss

The results obtained after the simulation of an antenna designed above are given for a number of parameters such as return loss, impedance bandwidth, gain, smith chart and VSWR by using CST studio 2014.

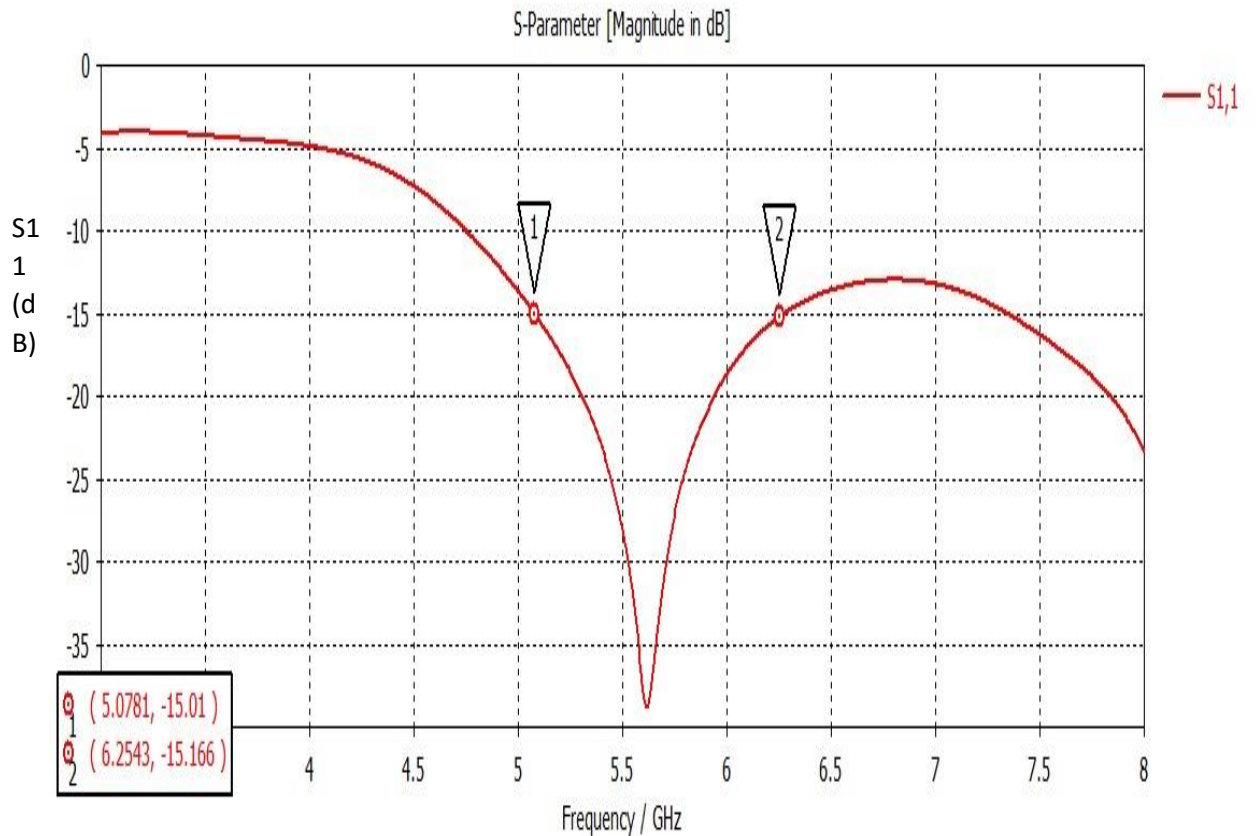

Figure 5.2 Plot representing S11 of Pythagoras Tree monopole fractal antenna

An antenna designed above displays a good return loss of approximately -38.75 dB at a frequency of 5.61 GHz frequency which is a good result. This antenna resonates at 5.62 GHz frequencies and provides us with a bandwidth of 1.18 GHz approximately. For calculating the bandwidth, lower frequency is subtracted from the upper frequency at -15dB. Figure 5.2 represent the variation of Return Loss with Frequency. The plot shows that the antenna is resonating at 5.62 GHz and provide us with a minimum return loss of -38.75 dB.

## 2. Smith Chart

The Smith Chart plot for the three iteration Pythagoras Tree monopole fractal antenna on CST Microwave Studio software is shown in Figure 5.3. Markers 1 and 2 shows the bandwidth at resonant frequency 5.62 GHz.

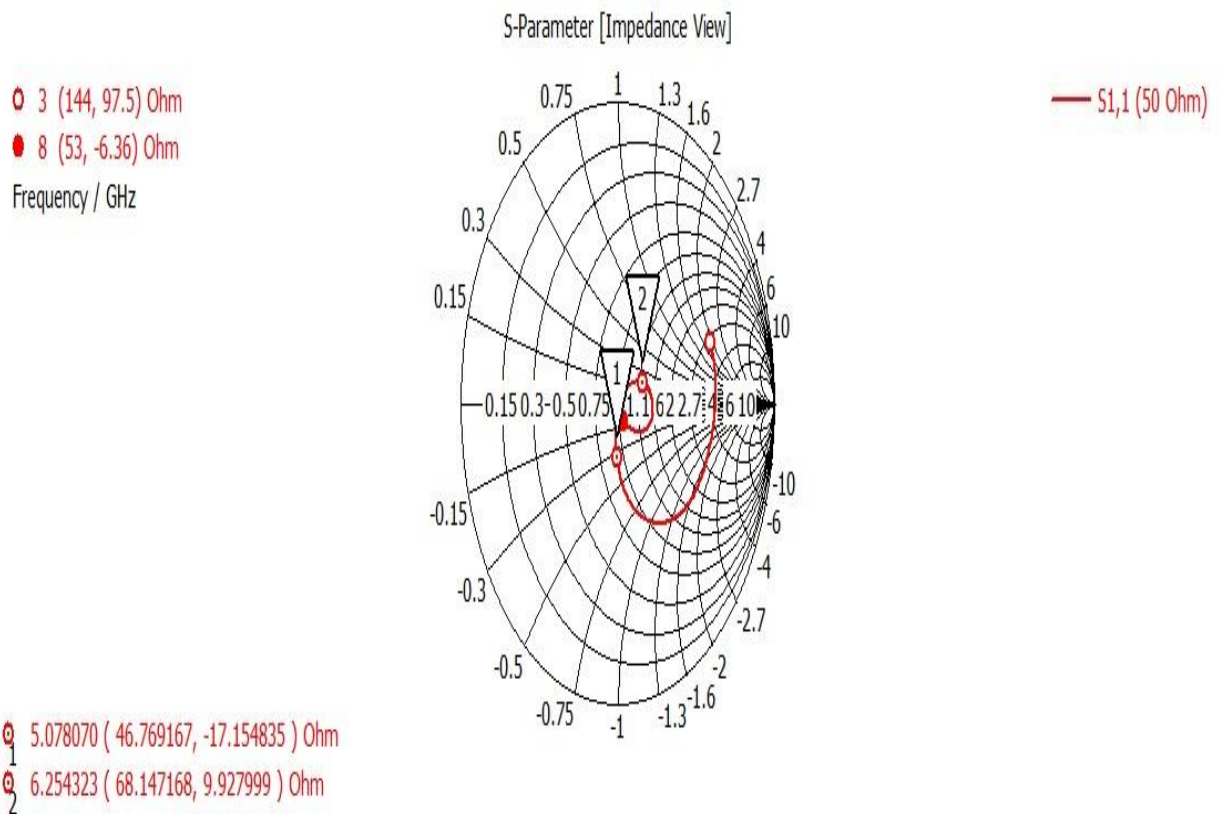

Figure 5.3 Simulated Smith chart

### 3. Directivity

The 3-D and Polar plot of radiation which are being radiated by an antenna designed in association with directivity is depicted in Figure 5.4(a) and (b). Gain and Directivity are related to each other by formula  $G = k D$ . The 'k' in the expression is radiation efficiency. Its maximum value is unity. The designed antenna gives the directivity of 2.761 dB at a frequency of 5.62 GHz.

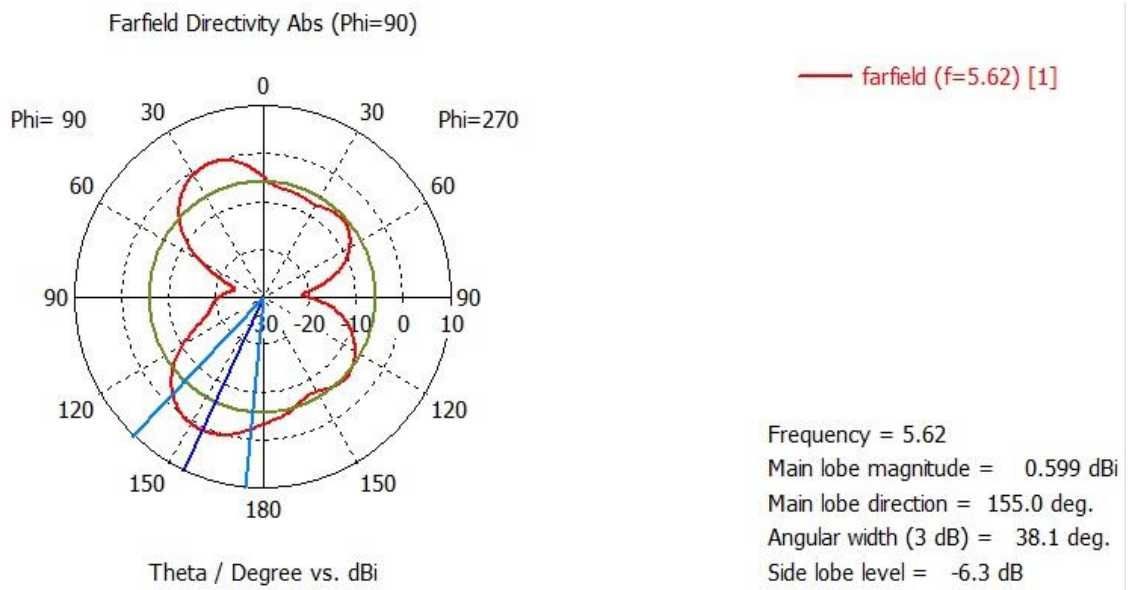

Figure 5.4a) Polar Plot

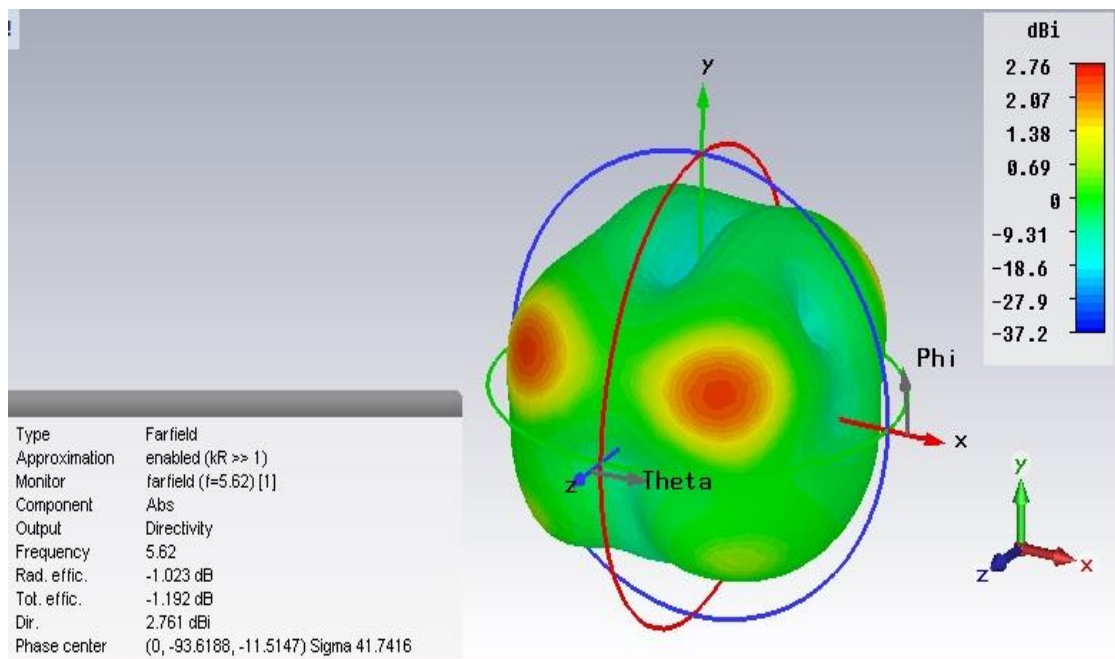

Figure 5.4b) 3D Plot

#### 4. Gain

The plot depicting the simulated gain of antenna designed is illustrated in Figure 5.5(a) and (b). The antenna proposed resonates at the frequency 5.62 GHz. The gain obtained is 1.738 dB at 5.62 GHz.

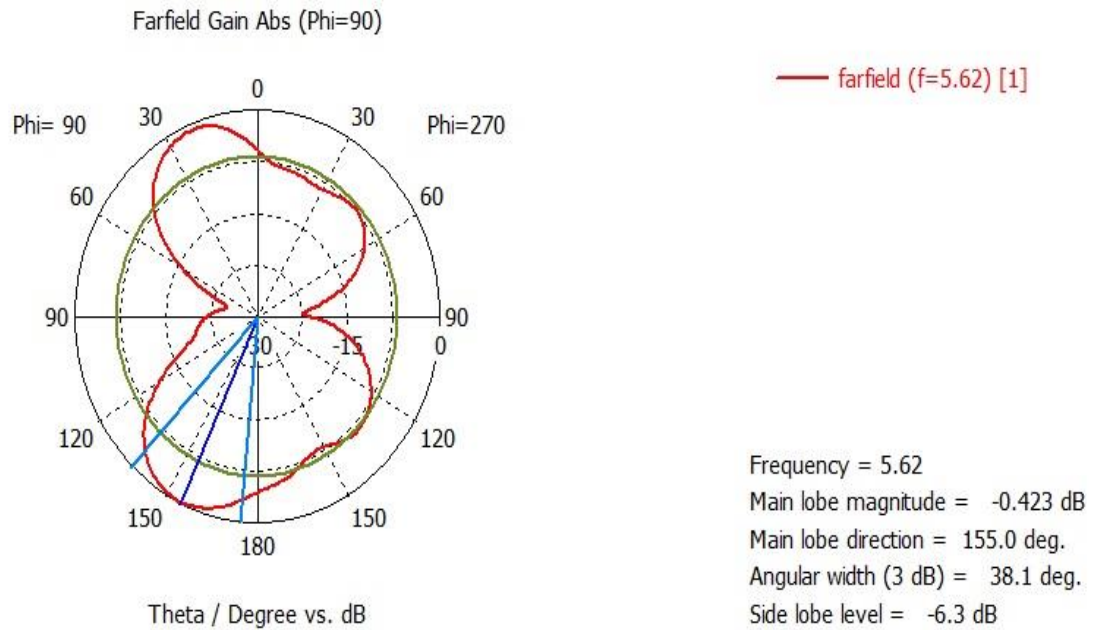

Figure 5.5 a) Polar Plot

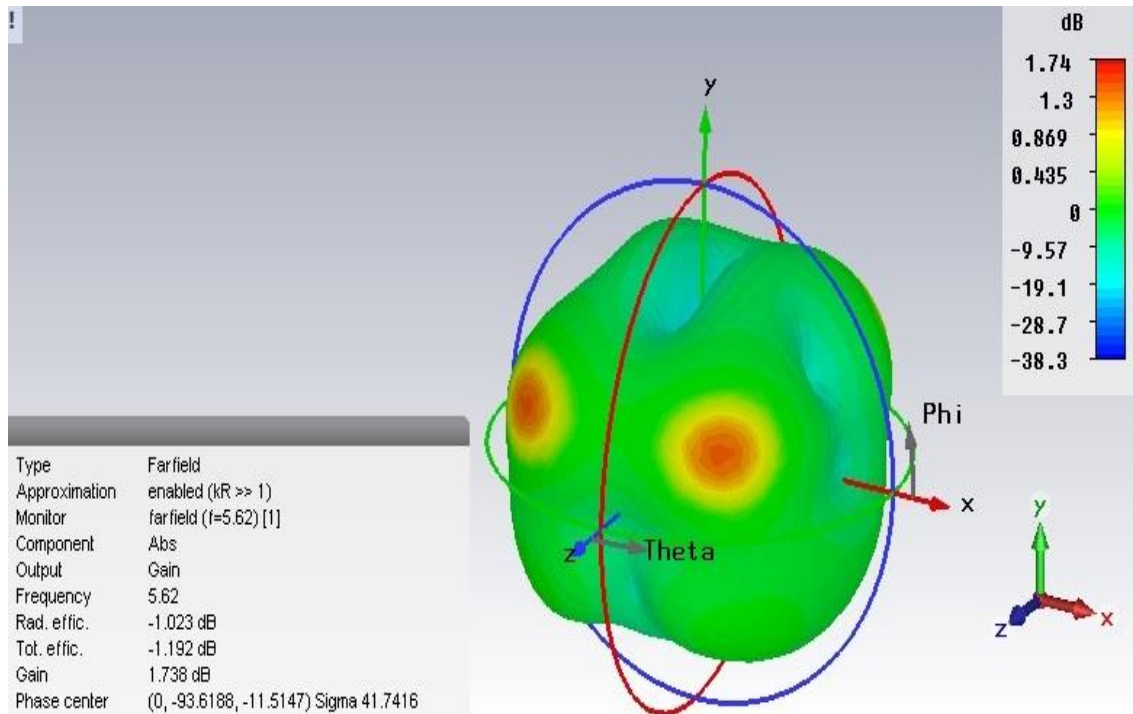

Figure 5.5 b) 3-D Plot

## 5. VSWR

The VSWR is the extent of discrepancy between the impedance of feeder line and impedance of the conducting patch of an antenna. Figure 5.6 depicts the VSWR of simulated Pythagoras tree monopole fractal antenna. According to the plot the reflection coefficient of simulated antenna at the resonating frequency is 1.02. Ideally the reflection coefficient must be equal to 1, which is practically unachievable. So every antenna is designed with an objective to keep reflection coefficient equal to 1.

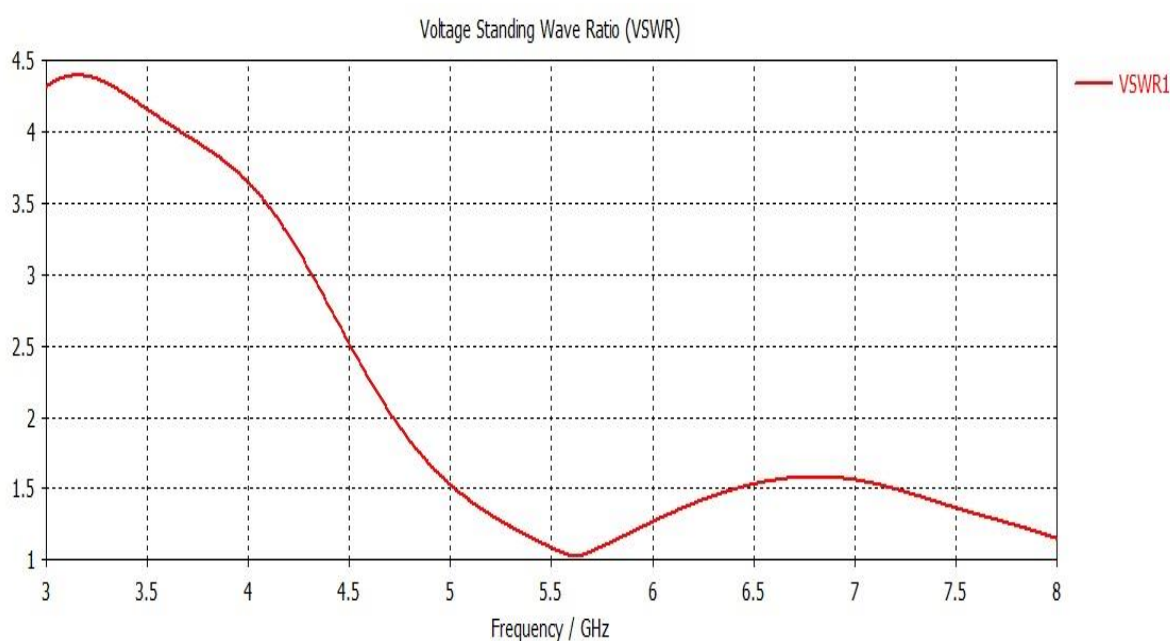

Figure 5.6 VSWR vs. Frequency Plot

## 6. Sweep Parameter, $L_g$

The simulation results also shows that the physical parameters like length of patch, width of patch, length of slot, width of slot, feed line width etc. also influences the results of the antenna. Figure 5.7 shows the parametric sweep on the length of ground  $L_g$ . By applying a sweep on the length of ground, as the length of ground is decreased from 90 mm to -85 mm for 5.62 GHz antenna designed the optimized results is obtained at -85 mm length of ground with a return loss of -38.75 dB and a resonating frequency of 5.62 GHz.

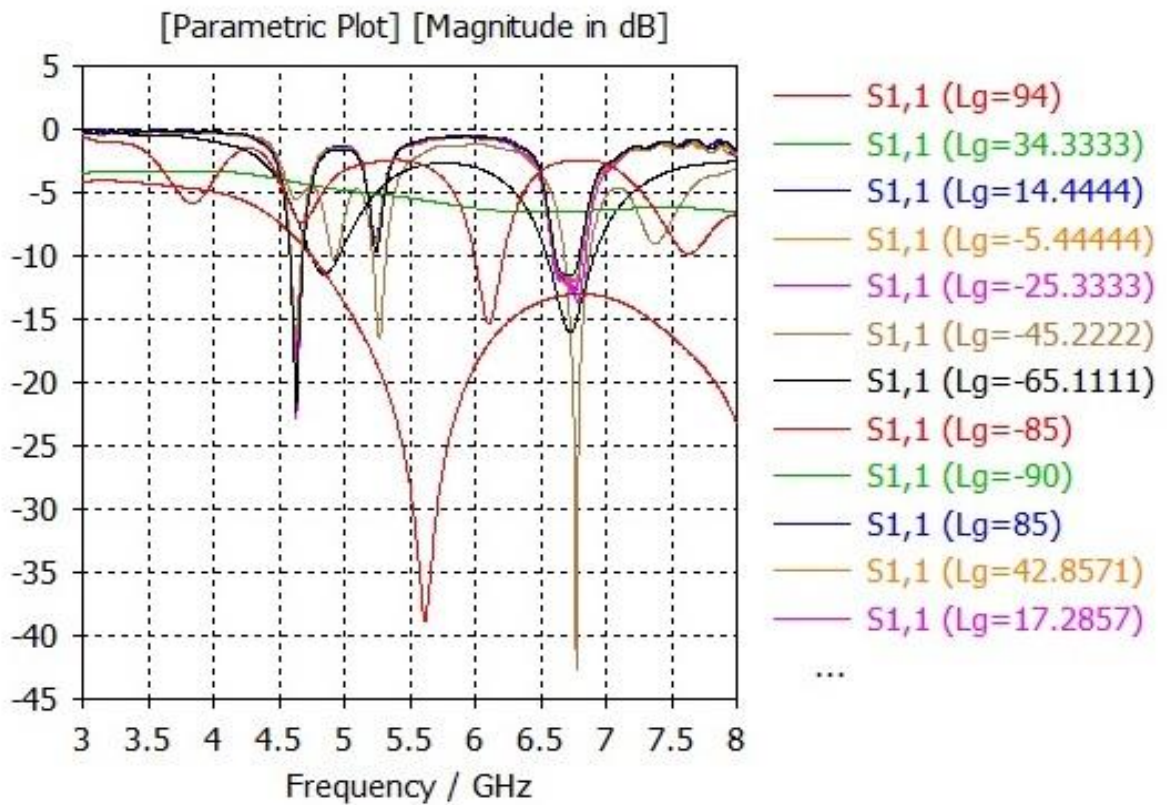

Figure 5.7 Parametric Sweep on the ground length

### 7. Sweep parameter, $W_f$

Figure 5.8 shows the parametric sweep on the feed line width,  $W_f$ . By applying the parametric sweep on the width of feed line, as the width of feed line is increased from 2.2 mm to 3.137 mm for 5.62 GHz antenna designed, the optimized results is obtained at 2.391 mm width with a return loss of -38.75 dB and a frequency resonating at 5.62 GHz

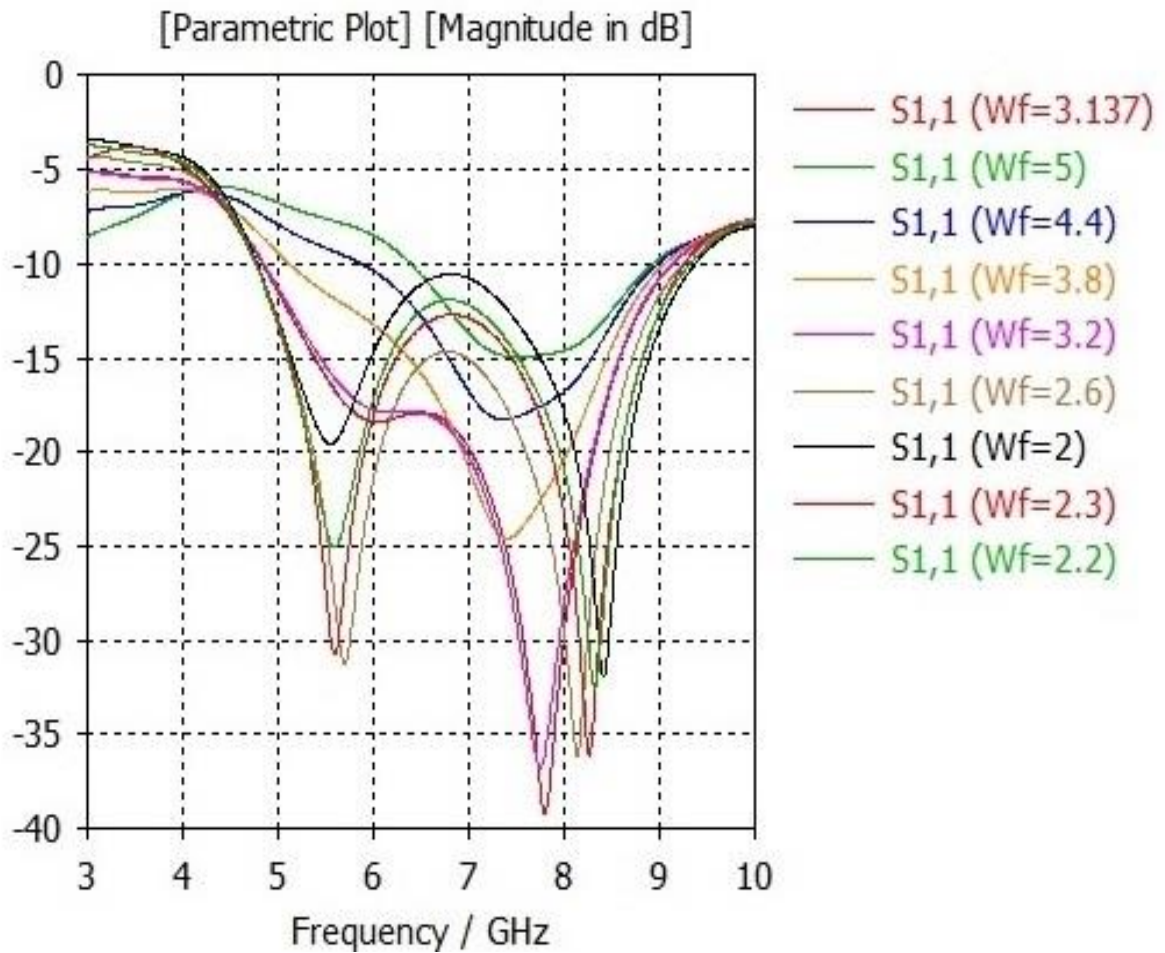

Figure 5.8 Parametric Sweep on feed line width

### 5.3 CONCLUSIONS

The aim of this chapter was to design and simulate a compact antenna for WiFi/WLAN applications. The simulated result of various parameters of the above designed antenna has been discussed above. It is seen that a bandwidth of 1.18 GHz for  $VSWR < 2$ , Gain of 1.738 dB and Directivity of 2.761 dB is obtained for the designed antenna.

<b>Parameters</b>	<b>Values</b>
Operating Frequency	5.62 GHz
Return Loss	-38.75 dB
Impedance	50 ohms
Bandwidth	1.18 GHz
Gain	1.738 dB
Directivity	2.761 dB

Table 5.1 Summary of the Antenna Parameters of Designed Antenna at 5.62 GHz frequency

## CHAPTER 6

### CONCLUSION AND FUTURE SCOPE

---

#### 6.1 CONCLUSION

- The design and simulation of Pythagoras tree shaped monopole fractal antenna using microstrip line feeding is presented and successfully implemented in this thesis report.
- In this work, different performance parameters of an antenna such as s-parameter or return loss, smith chart, far-field radiation pattern and VSWR have been perceived and analyzed by taking into account the simulation results. The proposed antenna is simulated over the frequency range 3 - 10 GHz along with  $VSWR < 2$ .
- The result reveals that the antenna designed resonates at 5.61GHz frequency that provides with a minimum return loss of -38.75 dB which is a good result.
- The impedance bandwidth of 1.18GHz for  $VSWR < 2$  is achieved. This shows that the use of fractal geometry shows broadband operations without employing any further modifications for different wireless operations such as WiFi, WiMax and different satellite mobile communications.
- In this work, the analysis and results also shows that there comes the change in the resonance effect as the length of the ground plane and the position of the feed is varied accordingly. Hence, to avoid this, an optimization is done in the width of feed  $w_f$ , its position and length of the ground so as to achieve the VSWR and impedance within the acknowledged levels.

#### 6.2 FUTURE SCOPE

Ever since the research in the field of fractal antenna engineering is still in its inception, there are a lot of opportunities to be done in future on this subject. There are many promising fractal structures that are existent which may undoubtedly have desired radiation properties. Thus, to interrogate further types of fractals in various applications of an antenna is a possible methodology for the future work. The following suggests some of the ideas for forthcoming work:

- Antennas using other fractal geometries like V-Koch, Sierpinski gasket, and Multi-band fractal antenna can be designed.

- The investigation of new techniques that attempt to diminish the size and enhance the bandwidth of fractal wideband antennas to make its utility possible in portable devices. Due to its high bandwidth, it can be integrated in mobile communication
- From the results, it has been revealed that the simulated gain of the antenna designed is low. To overwhelm this in future, the advancement in the approaches can be employed to improve the gain of these antennas.

## REFERENCES

---

- [1] Balanis CA, *Antenna Theory Analysis and Design*, Third Edition, John Wiley and Sons Inc, Hoboken, New Jersey, 2005
- [2] Anitha VR and Sindhu MY (2013). Simulation of a novel design fractal tree antenna for multiband applications with re-configurability, *2013 IEEE transactions*, 1489-1492
- [3] Manjibhai DA, Prajapati JC and Barasara DJ (2012). An Overview of Fractal Geometries and Antenna, *International Journal of Engineering and Science*, vol. 1(2), 1-4
- [4] Kumar A, Dutta BJ and Budhaliya S (2013). Iterated Pythagorean Fractal Tree Multiband Antenna, *International Journal of Scientific and Research Publications*, vol. 3( 9), 1-3
- [5] Khobragade SV and Anitha V R (2012). Design and simulation of fractal tree antenna for wireless application, *International Journal of Electronics and Communication Engineering & Technology (IJECECT)*, vol. 3(1), 178-187
- [6] Sahni S, Gupta V and Negi S (2015). Design and Simulation of Pythagorean Tree Monopole Fractal Antenna, *International Journal of Scientific & Engineering Research*, vol. 6(1), 1011-1014
- [7] Khobragade SV, Dr. Anitha VR and Bhosale J (2011). Fractal Tree Antenna WLAN Application, *IEEE transactions*, 309-311
- [8] Sharma R and Kokane DN (2016). Pythagorean Tree Shaped Antenna for Multi-Band Application, *International Conference on Electrical, Electronics, and Optimization Techniques (ICEEOT)*, 2634-2637
- [9] Vinoy KJ, Abraham JK and Varadan VK (2003). Fractal Dimension and Frequency Response of Fractal Shaped Antennas, *IEEE transactions*, 222-225
- [10] Bhosale JS, Jagdale SS and Deosarkar S.B (2012). A Comparative Study of Feeding Methods for Novel Design Fractal Tree Antenna, *International Journal of Engineering and Innovative Technology (IJEIT)*, vol. 2(6), 109-112
- [11] Stevens RT, "Fractal Programming in C", *Redwood City, CA: M&T Books*, 1989
- [12] Pourahmadazar J, Ghobadi C and Nourinia J (2011). Novel Modified Pythagorean Tree Fractal Monopole Antennas for UWB Applications, *IEEE Antennas and Wireless Propagation Letters*, vol.10, 484-487
- [13] Patel N, Singh J and Tiwari M (2014). Rectangular Microstrip Patch Antenna for Wireless Communications at 6.5 GHz, *International Journal of Scientific & Engineering Research*, vol. 5 (3), 990-993
- [14] Breden R and Langley RJ (1999). Printed Fractal Antennas, *Proceeding of the IEEE National Conference on Antennas and Propagation*, 1-4
- [15] David M. Pozar, *Microwave Engineering*, John Wiley & Sons, 1998
- [16] Altun H, Korkmaz E, and Turetken B (2011). Reconfigurable Fractal Tree Antenna for Multiband Applications, *2011 IEEE transactions*, 1-4

- [17] Werner DH, Werner PL and Ferraro AJ (1996). Frequency Independent Features Of Self-Similar Fractal Antennas, *1996 IEEE transactions*, 2050-2053
- [18] Kumar D, Kumar A and Singh AK (2014). Design Analysis of Pythagoras Tree Shaped Multiband Fractal Antenna, *2014 Sixth International Conference on Computational Intelligence and Communication Network*, 41-45
- [19] Xu L and Chia MYW (1999). Multiband Characteristics of Two Fractal Antennas,"*Microwave and Optical Technology Letters*, vol.23(4), 242-245
- [20] Aggarwal A and Kartikeyan MV (2010). Pythagoras Tree: A Fractal Patch Antenna for Multi-Frequency and Ultra-Wide Bandwidth Operations, *Progress In Electromagnetics Research C*, vol.16, 25-35
- [21] Mandelbrot B, "The fractal Geometry of Nature," *New York: W. H. Freeman*, 1983
- [22] Werner DH and Ganguly S (2003). An Overview of Fractal Antenna Engineering Research, in *IEEE Antennas and Propagation Magazine*, vol.45, no.1, 38-57
- [23] Poprzen N and Gacanovic M (1999). Printed Fractal Antennas, *Proceeding of the IEEE National Conference on Antennas and Propagation*, 1-4
- [24] Oliveira C *et al.* (2009). Overall Size Antenna Reduction Using Fractal Elements, *Microwave and Optical Technology Letters*, vol. 51(3), 671-675
- [25] Sivia JS and Bhatia SS (2015). Design of Fractal Based Microstrip Rectangular Patch Antenna for Multiband Applications, *2015 IEEE International Advance Computing Conference (IACC)*, 712-715
- [26] Singh K, Grewal V and Saxena R (2009). Fractal Antennas: A Novel Miniaturization Technique for Wireless Communications, *International Journal of Recent Trends in Engineering*, vol. 2, no. 5, 172-176
- [27] Yadav SK, Vyas K and Kumar S (2013). A Pythagoras Tree Shape Fractal Antenna for Multiband Applications, *International Journal of Emerging Technology and Advanced Engineering*, vol. 3(12), 572-576
- [28] Sindou M, Ablart G, and Sourdois C (1999). Multiband and Wideband Properties of Printed Fractal Branched Antennas," *IEE Electronics Letters*, vol.35, no.3, 181-182
- [29] Arora A *et al.* (2015). Comparative Study of Different Feeding Techniques for Rectangular Microstrip Patch Antenna, *International Journal of Innovative Research in Electrical, Electronics, Instrumentation and Control Engineering*, vol. 3 (5), 32-35
- [30] Parmar SR and Singh H (2017). Analysis of Fractal Geometries and its Applications in Microstrip Antenna, *International Journal of Advanced Research in Computer Science*, 194-198, vol. 8, no. 4
- [31] Kaur R, Singh S and Kumar N (2015). A Review of Various Fractal Geometries for Wireless Applications, *Int. Journal of Electrical & Electronics Engg.*, vol. 2(1), 34-36
- [32] Werner DH, Haup RL and Wernej PL (1999). Fractal Antenna Engineering: The Theory and Design of Fractal Antenna Arrays, *Antennas and Propagation Magazine*, vol. 41, no. 5

- [33] Upadhyay S and Jain L (2016). Fractal Antenna for UWB Applications: A Review, *International Journal of Computer Applications*, vol. 145, no.9, 27-32.
- [34] Kaur A and Singh G (2014). A Review Paper on Fractal Antenna Engineering, *International Journal of Advanced Research in Electrical Electronics and Instrumentation Engineering*, vol. 3(6), 9983-9989.
- [35] Kumar R, Malathi P and Shinde JP (2007). Design of Miniaturized Fractal Antenna, *37th European Microwave Conference*.
- [36] Poonam S and Jadhav MM (2016). Review on Fractal Antenna for Wireless Communication, *International Journal of Latest Trends in Engineering and Technology (IJTET)*, vol. 6(3), 451-454.
- [37] Verma S and Verma A (2014). A Review of Miniature Fractal Antenna Design for Wireless Communication, *International Journal of Advanced Research in Electrical, Electronics and Instrumentation Engineering*, vol.3 (9).
- [38] Srivastava P and Singh OP (2015). Literature Survey on Monopole Fractal Antennas, *International Journal for Research in Applied Science & Engineering Technology (IJRASET)*, 1012-1016, vol. 3(V).
- [39] Kohli S, Dhillon SS and Marwaha A (2013). Design and Optimization of Multiband Fractal Microstrip Patch Antenna for Wireless Application, *IEEE computer society*.
- [40] Karmakar A *et al.* (2013). Design and analysis of fractal based UWB Monopole Antenna, *IEEE transacions*, 1-5.
- [41] Cohen N (1997). Fractal Antenna Applications in Wireless Telecommunications, *Proceedings of the Electronics industries Forum of New England*, 43-49.
- [42] Gupta VR and Gupta N (2007). Analysis of a Fractal Microstrip Patch Antenna, *International Journal of Microwave and Optical Technology*, vol.2, no. 2, 124-129.
- [43] Song HW *et al.* (2007). Design of the Tree-Shaped UWB Antenna Using Fractal Concept, *Korea-Japan Microwave Conference, 2007 IEEE transactions*, 73-76.

ORIGINALITY REPORT

---

% **19**  
SIMILARITY INDEX

% **13**  
INTERNET SOURCES

% **10**  
PUBLICATIONS

% **12**  
STUDENT PAPERS

---

PRIMARY SOURCES

---

**1** Kumar, Devesh, Amit Kumar, and Anurag Kumar Singh. "Design Analysis of Pythagoras Tree Shaped Multiband Fractal Antenna", 2014 International Conference on Computational Intelligence and Communication Networks, 2014.  
Publication % **1**

---

**2** Submitted to Thapar University, Patiala  
Student Paper % **1**

---

**3** Submitted to Higher Education Commission Pakistan  
Student Paper % **1**

---

**4** Submitted to Universiti Teknologi MARA  
Student Paper % **1**

---

**5** [dspace.thapar.edu:8080](https://dspace.thapar.edu:8080)  
Internet Source % **1**

---

**6** [ijarcsse.com](http://ijarcsse.com)  
Internet Source % **1**

---

**7** Submitted to Punjab Technical University

% 1

---

8 eprints.utm.my  
Internet Source

% 1

---

9 www.jpier.org  
Internet Source

% 1

---

10 Sivia, Jagtar Singh, and Sumeet Singh Bhatia.  
"Design of fractal based microstrip rectangular  
patch antenna for multiband applications",  
2015 IEEE International Advance Computing  
Conference (IACC), 2015.  
Publication

% 1

---

11 Submitted to Symbiosis International University  
Student Paper

% 1

---

12 www.coursehero.com  
Internet Source

% 1

---

13 ijeit.com  
Internet Source

% 1

---

14 Khobragade, Sanjay V., V. R. Anitha, and  
Janakiraje Bhosale. "Fractal tree antenna  
WLAN application", 2011 3rd International  
Conference on Electronics Computer  
Technology, 2011.  
Publication

<% 1

---

15 Submitted to Jawaharlal Nehru Technological

16

[ethesis.nitrkl.ac.in](http://ethesis.nitrkl.ac.in)

Internet Source

<% 1

17

[www.ukessays.com](http://www.ukessays.com)

Internet Source

<% 1

18

Submitted to Panjab University

Student Paper

<% 1

19

[eprints.uthm.edu.my](http://eprints.uthm.edu.my)

Internet Source

<% 1

20

Karmakar, Anirban, Utsab Banerjee, Rowdra Ghatak, and D R Poddar. "Design and analysis of fractal based UWB monopole antenna", 2013 National Conference on Communications (NCC), 2013.

Publication

<% 1

21

[fiyands.te.student.pens.ac.id](http://fiyands.te.student.pens.ac.id)

Internet Source

<% 1

22

[www.educatorscorner.com.cn](http://www.educatorscorner.com.cn)

Internet Source

<% 1

23

Suganthi, S., K. S. Tharini, P. S. Sarankumar, S. Raghavan, and D. Kumar. "Design and simulation of planar Minkowski fractal antennas", 2011 2nd International Conference on Wireless Communication Vehicular

<% 1

Technology Information Theory and Aerospace  
& Electronic Systems Technology (Wireless  
VITAE), 2011.

Publication

24

Submitted to National Institute of Technology,  
Rourkela

Student Paper

<% 1

25

[ijartet.com](http://ijartet.com)

Internet Source

<% 1

26

Submitted to Jacobs University, Bremen

Student Paper

<% 1

27

[www.csjournals.com](http://www.csjournals.com)

Internet Source

<% 1

28

Jin-Suk Kim. "Design of the Tree-Shaped UWB  
Antenna Using Fractal Concept", 2007 Korea-  
Japan Microwave Conference, 11/2007

Publication

<% 1

29

Kashwan, K R, V Rajeshkumar, T  
Gunasekaran, and K R Shankar Kumar.  
"Design and characterization of Pin fed  
microstrip patch antennae", 2011 Eighth  
International Conference on Fuzzy Systems  
and Knowledge Discovery (FSKD), 2011.

Publication

<% 1

30

E. E. C. de Oliveira. "Overall size antenna  
reduction using fractal elements", Microwave

<% 1