

# **Novel Approaches for increasing Energy Efficiency in Wireless Sensor Network**

*Thesis submitted in partial fulfillment of the requirements for the award of degree of*

**Master of Engineering**  
in  
**Information Security**

*Submitted By*  
**Onkar Singh Taneja**  
**(Roll No. 801233013)**

Under the supervision of:  
**Mr. Vinod Kumar Bhalla**  
**Assistant Professor**



COMPUTER SCIENCE AND ENGINEERING DEPARTMENT  
THAPAR UNIVERSITY  
PATIALA – 147004

**June 2014**

## Certificate

---

I hereby certify that the work which is being presented in the thesis entitled, “ *Novel Approaches for increasing Energy Efficiency in Wireless Sensor Network* ”, in partial fulfillment of the requirements for the award of degree of Master of Engineering in *Information Security* submitted in Computer Science and Engineering Department of Thapar University, Patiala, is an authentic record of my own work carried out under the supervision of *Mr. Vinod Kumar Bhalla* and refers other researcher’s work which are duly listed in the reference section.

The matter presented in the thesis has not been submitted for award of any other degree of this or any other University.



Onkar Singh Taneja

This is to certify that the above statement made by the candidate is correct and true to the best of my knowledge.

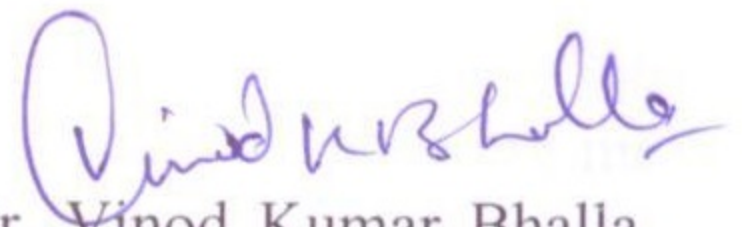

Mr. Vinod Kumar Bhalla  
Assistant Professor  
CSED, Thapar University

Countersigned by

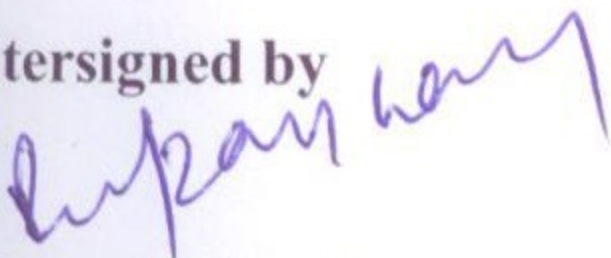

(Dr. Deepak Garg)

Head  
Computer Science and Engineering Department  
Thapar University  
Patiala



(Dr. S. K. Mohapatra)  
Dean (Academic Affairs)  
Thapar University  
Patiala

## Acknowledgement

---

No volume of words is enough to express my gratitude towards my guide, **Mr. Vinod Kumar Bhalla**, Assistant Professor, Computer Science and Engineering Department, Thapar University, who have been very concerned and have aided for all the material essential for the preparation of this thesis report. He helped me to explore this vast topic in an organized manner and provided me with all the ideas on how to work towards a research oriented venture.

I am also thankful to **Dr. Deepak Garg**, Head of Department, CSED, **Dr. Maninder Singh**, Associate Professor, **Dr. Jhilik Bhattacharya**, P.G. Coordinator, for the motivation and inspiration that triggered me for the thesis work.

I would also like to thank the staff members and my colleagues who were always there in the need of the hour and provided with all the help and facilities, which I required, for the completion of my thesis.

Most importantly, I would like to thank my **Parents** and the **Almighty** for showing me the right direction out of the blue, to help me stay calm in the oddest of the times and keep moving even at times when there was no hope.

**Onkar Singh Taneja**  
**801233013**

## Abstract

---

Wireless sensor network is made up of very tiny motes called as sensor nodes and a fixed or mobile base station. For making the network reliable many routing algorithms are proposed. The important features for making the system reliable are flexibility, ability of self organizing and to be energy efficient. Due to the presence of sensor nodes in harsh environment it is not possible to provide unlimited power source so, energy efficiency is a major issues in WSN. Multi-objective Approach for Energy Efficiency and Multi-objective Cluster Based Approach protocols are proposed to increase life cycle of network. In these protocols the cost of each link is calculated and assign to each path and Minimum spanning tree are formed by using greedy approach. These protocols require multiple objectives such as residual energy, transmission energy and delay for finding the best and shortest routing path to base station. The proposed protocol shows better results as compared with LEACH protocol.

# Table of Contents

---

---

Certificate.....	i
Acknowledgement.....	ii
Abstract.....	iii
Table of Contents.....	iv
List of Figures.....	v
List of Tables.....	vi
Abbreviations.....	viii
<b>Chapter 1: Introduction</b>	<b>1</b>
1.1 Background Information .....	1
1.2 Wireless Sensor Network .....	2
1.2.1 Evolution of Sensor Network .....	2
1.2.2 Classification of WSNs .....	3
1.2.3 WSN Architecture .....	5
1.2.4 Sensor Node Architecture.....	6
1.2.5 Protocol Stack in Sensor Nodes.....	7
1.2.6 Characteristics of Wireless Sensor Networks.....	9
1.2.7 Wireless Sensor Network Applications.....	9
1.2.8 Wireless Sensor Networks vs. Wireless Ad-hoc Networks.....	11
1.2 Routing in wireless sensor network .....	12
1.3.1 Routing Challenges and Design Issues.....	13
1.4 Problem Statement .....	15
<b>Chapter 2: Literature Survey</b>	<b>16</b>
<b>Chapter 3: Network Design</b>	<b>24</b>

3.1 Design Terminology.....	24
3.2 Energy Model Used for WSNs.....	25
3.3 Deployment Methodology.....	26
3.4 Sensor and Relay Node Information .....	27
<b>Chapter 4:Proposed Work</b>	<b>28</b>
4.1 Cost Estimation Function.....	28
4.2 Link Cost Function.....	28
4.3 Multi-objective Approach for Energy Efficiency (MAEE) .....	29
4.3.1 Algorithm.....	30
4.4 Energy Deduction.....	31
4.4.1 Energy Consumed.....	32
4.4.2 End To End Delay .....	32
4.4.3 Packet Loss Probability .....	32
4.5 Multi-objective Cluster Based Approach for Energy Efficiency (MCBA).....	33
4.5.1 Algorithm.....	34
<b>Chapter 5: Results</b>	<b>36</b>
<b>Conclusion and Future Scope</b>	<b>42</b>
<b>References</b>	<b>43</b>
<b>List of Publication</b>	<b>47</b>

## List of Figures

---

1.1 WSN Architecture.....	5
1.2 Sensor Node Architecture.....	6
1.3 Protocol Stack for Sensor Node.....	7
3.1 Radio model.....	26
3.2 Random Deployment.....	26
3.3 Node Structure.....	27
4.1 Packet Format.....	29
4.2 MAEE.....	30
4.3 Packet Loss Probability of Network.....	33
4.4 Average Energy Consumption.....	33
4.5 MCBA.....	34
5.1 Simulation Results for the lifetime of the network.....	40
5.2 Simulation Results for FND, HND and LND.....	41

## List of Tables

---

1 Classes for Path Selection.....	28
2 Simulation results for a 60m*60m network with initial energy 0.5J/node.....	36
3 Requirements.....	40

## Abbreviations

---

ADC	Analog To Digital Convertor
BCDCP	Base Station Controlled Dynamic Clustering Protocol
BS	Base Station
CH	Cluster Head
MAEE	Multi-objective approaches for Energy Efficiency
MANET	Mobile ad-hoc Network
MCBA	Multi-objective Cluster Based Approaches
NHRA	Novel Hierarchy Routing Algorithm
IEEE	Institute of Electrical and Electronics Engineers
IP	Internet Protocol
LEACH	Low Energy Adaptive Cluster Hierarchy
SNR	Signal-to-noise Ratio
Qos	Quality of Service
WSN	Wireless Sensor Network

### 1.1 Background Information

Tremendous research in the area of MEMS and wireless communication have setup a milestone in the development of low-power, low-cost sensor devices. The development of the sensor devices have greatly contributed in the establishment of wireless sensor network. These sensors nodes are small in size with low computational power and small memory size so, they are less expensive. These sensor nodes act as a backbone of wireless sensor network. These nodes sense and collect data from the environment and perform some computation on the data. After performing computation transmit the sensed information to the end-user. Sensor nodes or motes are deployed randomly or uniformly in the sensing area. These sensor devices are made up to sense the different parameter such as temperature, moisture, vehicle movement, soil temperature, etc. Sensor technology has various applications in the field of military, health, home and healthcare etc. Zigbee (IEEE 802.15.4) is most popular protocol for creating a wireless sensor network.

Advancement in the processor-speed and memory size has led to the minimization of these sensor devices. But the development in the energy technology is slow. So, power is most scarce resource in sensor. The nodes communicate with each other via wireless channel. There is lot of research is going on to minimize the amount of wireless communication. Wireless communication is the most energy consuming task. The route of the data from the node to the sink node is very crucial in terms of lifetime of a network. For example by using short routes to the sink node the nodes batteries depleted quickly which decreases the lifetime of the network and secondly by using a longest route consists of many nodes causes the significantly increase in the network delay. Always choosing the shortest path towards the sink node make the energy at the intermediate nodes to be consumes faster, this decreases the lifetime of the network. But at the same time selecting the shortest path reduces the power consumption and network delay. The routing protocols are designed according to the need of application for e.g. real-time applications requires less network delay and the

applications that performs the statistical calculations requires high network lifetime. Hence, different routing protocols are proposed according to different applications.

## **1.2 Wireless Sensor Network**

Wireless sensor network comprises of large no. of tiny, autonomous, self-organizing motes or sensor nodes that are scattered randomly or uniformly in sensing area. These nodes combine with router and gateway creates a wireless sensor network. In WSNs motes communicates in ad-hoc way in that routes between the motes are dynamically changing. These nodes communicate with each other via radio frequency channel. Each sensor node sense the network and waiting for the event for triggered. When the event is triggered first the information is processed from analog data to digital data and sends to the BS either by direct transmission or by multi hop communication. Mote communicates with neighbor nodes via radio frequency channel. The wireless communication consumes lot of energy and the sensor nodes have a small battery backup. The sensors nodes are deployed in a harsh environment where it is not possible to replace the battery, so once the energy is depleted node is dead. Energy efficiency is a big concern in the wireless sensor network. Energy efficiency in WSNs has attracted many researchers over the years.

### **1.2.1 Evolution of Sensor Network**

During the Cold War sensor network establishment was started by the United States. Large number of acoustic sensors was deployed at pre-planned position at the bottom of the sea to discover and track soviet submarines. The network of acoustic sensors was known as Sound Surveillance System (SOSUS). In SOSUS the human operators played a very important part. The SOSUS has the wired sensor network as it did not have the energy bandwidth problem of wireless network. In 1980, Defense Advanced Research Projects Agency (DARPA) started the research on sensor network and named the program as Distributed Sensor Networks (DSN).DSN includes acoustic sensors communication, processing techniques, self-location algorithms for sensors and distributed software.

Recent development in the field of computing and communication is responsible for the significant shift in the research of sensor network and Micro-electro-mechanical system (MEMS) technology based small and cheaper sensors, wireless

communication and cheaper low-power processors make way for the deployment of wireless ad hoc networks for different applications. Thus, the system designed with new routing techniques is compatible with highly dynamic ad-hoc networks. The wireless networks that are based upon IEEE 802.11 standards provide bandwidth as compared to those of wired networks. IEEE has also noticed the low expense and high capabilities that sensor networks offer.

The IEEE has defined the standard for personal networks known as IEEE 802.15. The personal area network has a radius of 5 to 10 m. Short-range sensors network is the well suited technology that can be employed in Personal Area Networks. Furthermore advancement in the chip capacity and processor capabilities has significantly reduce the energy per bit requirement for computing and communication. Now days a single chip is enough for performing sensing, computation and communication. Thus reduces the cost for deploying in large numbers.

### **1.2.2 Classification of WSNs**

The WSNs can be classified on the basis on the environment in which the sensor nodes are deployed. A sensor node can be placed on land, sea and underground. Sensor node faces different challenges depending upon the environment. There are five types of WSNs: terrestrial WSN, underwater WSN, underground WSN and mobile WSN.

- **Terrestrial WSNs:** Terrestrial WSNs comprises of thousands of sensor nodes deployed in ad-hoc manner or in pre-planned way in a given area. The Terrestrial WSNs sensor node has limited power supply but can also have a secondary power supply using solar cells. However still there is need for energy conservation. The energy can be saved with multi-hop routing, short range transmission, data aggregation, rectify data redundancy, and minimize delays.
- **Underground WSNs:** In underground WSNs the sensor node are placed inside a mine or cave to sense the underground conditions. The sink nodes are placed above the ground to gather information from the sensor node and transmit it to the base station. Underground sensor node have a small power supply once the power is depleted it is impossible to replace the battery. So

energy efficient communication protocol must be implemented to increase the lifetime of the network.

- **Underwater WSNs:** The sensor nodes are deployed underwater. Underwater WSNs are costly so only few sensor nodes are deployed. Underwater wireless communication is done through acoustic wave. There are several issues with the acoustic communication such as high propagation delay, fixed bandwidth and signal fading issues. Underwater sensor nodes have the self-configure capabilities to adapt the underwater harsh conditions. Underwater sensor node have a small battery once the power is depleted it is difficult to replace the battery. There is need of developing efficient underwater communication techniques.
- **Multi-Media WSNs:** Multi-Media WSNs are developed to record the events in multi-media form as images, audio and video. The multi-media sensor nodes are specially designed nodes that contain camera and microphone. The deployment of multi-media nodes is pre-planned. Multi-media WSN faces challenges such as high bandwidth required, high energy consumed, information processing and compression.
- **Mobile WSNs:** Mobile WSNs is made up of sensor nodes that are mobile and interact with the physical phenomenon. Mobile nodes have similar abilities of sensing, computing, and communicating like static nodes. The major difference is that mobile is able to change the position and re-organize the network. A mobile WSN just need some initial start-off deployment and then nodes move around the network to collect information. Mobile node can communicate with other mobile node within range of each other. The key challenges in mobile WSN are localization, navigation and control, coverage area, power, maintenance, and information processing

### 1.2.3 WSN Architecture

WSN typically consist of four components: Sensing Field, Sensor node, sink, task manager. The simple wireless sensor network architecture is shown below in figure 1.1

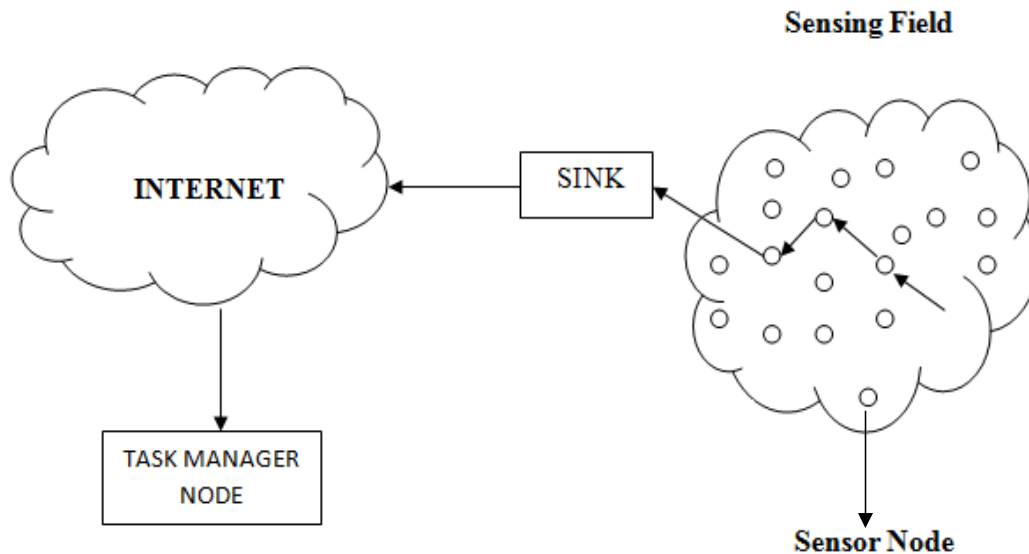

Figure 1.1: WSN Architecture

- **Sensing Area:** The area in which the sensors are deployed to sense the various parameter of that area.
- **Sensor Node:** Sensor nodes act as a backbone for the wireless sensor network. Sensor nodes are deployed randomly or uniformly in the sensor area. Sensor nodes sense the area and waits for the events to be triggered and transmit the information to sink or base station.
- **Sink:** Sink gathers data from the others sensor nod and perform aggregation of the data and sends this aggregated data to the base station. This way sink reduces the energy consumption of the network. Any node can act as a sink according to the network requirement. They are also called as data aggregation points.
- **Task Manager:** Task Manager or Base station provides an access point for the user to process the information that is gather through the sensor node. Base station has a more complex processor and large storage space. The sink node sends the data to the base station via internet, wireless communication etc

#### 1.2.4 Sensor Node Architecture

Sensor node comprises of four basic parts: Sensing unit, Computing Unit, Communication unit and power unit. According to the demand of application node

can have some additional parts such as mobilizer, locator system, etc. The basic block diagram is as shown below in figure 1.2.

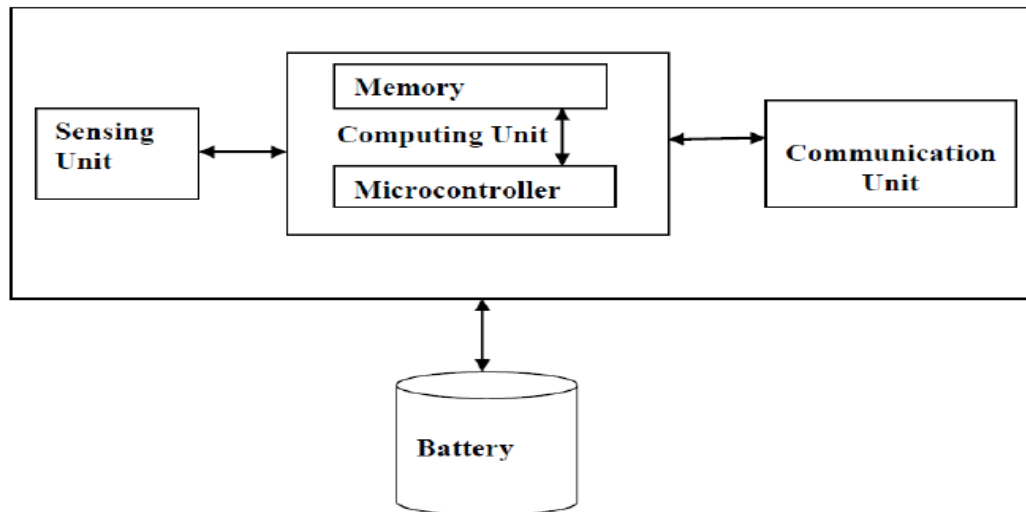

Figure 1.2: Sensor Node Architecture

- **Sensing Unit:** Sensing unit comprises of two subparts: sensor and ADC. Sensors as its name suggest that it detect any change in the physical phenomenon in the sensing area. The physical phenomenon is analog in nature. ADC (analog to digital converter) converts this physical phenomenon to digital and the result is then act as an input to the processing unit. At present there are different types of sensor that measures parameter such as temperature, humidity, vehicular movement etc.
- **Processing Unit:** The processing unit acts as a brain of the mote. The processing unit comprises of a microprocessor that control sensor, execute communication protocol and perform signal processing on the collected data. There are various operating systems for the motes. Tiny OS is the most popular operating system for the mote
- **Transceiver Unit:** Transceiver unit is responsible for the communication between the sensor node and the external network. It transmits and receives the information from the neighboring nodes.

- **Power Supply:** It provides power to run the sensor node. It decides the lifetime of the sensor node. Sensor node has a small battery backup due to its small size.

### 1.2.5 Protocol Stack in Sensor Nodes

The protocol stack for the base station and nodes is shown in figure below. It consists of different layers providing functionality such as communication between the sensor node and the base station, finds the best routing paths, integrate data at the network layer and energy efficiently communicating across the wireless medium. The protocol stack comprises of application layer, transport layer, network layer, data link layer, physical layer, power management plane, mobility management plane and task management plane. The protocol stack for wireless sensor network is shown below in figure 1.3

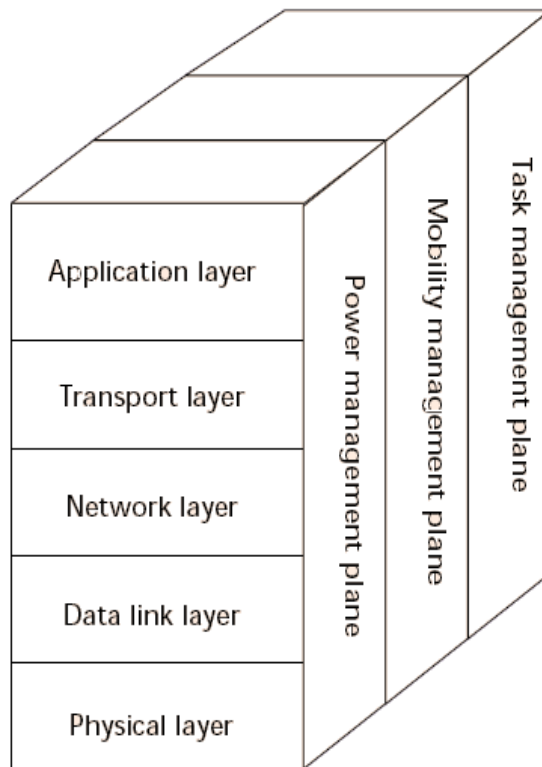

Figure 1.3: Protocol Stack

- **Physical layer:** It provides the functionality of carrier frequency generation and selection, signal detection and modulation, encrypting the data, receiving and transmitting functions.
- **Data link layer:** It provides the functionality of multiplexing data streams, medium access, errors control and data frame detection. It is also responsible for hop to hop and hop to multi-hop connection. The mac layer provides collision detection and makes the network energy efficient.
- **Network layer:** It provides the functionality of finding the best efficient path to route the data receive from the upper layer to the destination node.
- **Transport layer:** It is required when the sensor network is accessed through internet. It maintains the flow of control according to the requirement of the application.
- **Application layer:** It provides the way for the end-user to interact with sensor networks. It presents all the information to the application and forwards the requests from the application layer down to the lower layer

The power management plane is responsible for managing the energy utilization by the sensor nodes. Mobility management plane is useful when the sensor nodes are mobile. It manages and keeps a check on the movement of the mobile nodes. The task management plane is responsible for scheduling the sensing and forwarding data of the nodes to the base station. There are some limitations such as restricted channel bandwidth, restricted energy, mobility, electromagnetic wave propagation, error susceptible channel, time varying situations that should be met to design a network protocol for wireless devices.

There are some ideas that can be applied to excel these limitations. Low-energy protocols can be used to enhance the restricted node energy. Power control can be helpful in combating the radio wave attenuation. A transmitter can be used to the set the power of radio wave in such a way i.e. it will receive within an acceptable power level. Data link layer protocols and MAC protocols can be useful in tackling the errors in channels. Adaptive routing and link layer protocols can be applied to tackle the time-varying situations of the wireless channel and mobile

### 1.2.6 Characteristics of Wireless Sensor Networks

Wireless sensor network possess some unique characteristics that make it different from others wireless networks. Some of the unique characteristics are described as follows:-

- Sensor nodes are of small size and have small battery. Thus they have a limited supply of power. Once the power is depleted it is difficult to replace the battery as the sensor nodes are deployed in the harsh environment. So there is lifetime constraint in the sensor network.
- In Wireless Sensor Network, nodes are error-prone due to depletion of power, harsh environment conditions. The receiving and transmission links are error-prone due to sensor node error, unpredictable modulations, mobility and harsh environment conditions.
- Mobility of nodes, node failures and environment interferences causes dynamic nature of wireless sensor network. Dynamic nature causes frequent changes in the network topology and partitions. But the mobile nodes can still transfer the data across the partition by physical moving across them
- Wireless Sensor network may comprise of large number of nodes having different sensors, power level, computation power and memory size causes an issue of heterogeneity.

### 1.2.7 Wireless Sensor Network Applications

Wireless Sensor Network Applications are classified into two broad categories as:

1. **Monitoring:** It includes inventory location monitoring, power monitoring, health monitoring, etc.
2. **Tracking:** It includes chasing the objects, humans, vehicles and animals and categorizes the applications into health, military, home, etc.

These techniques can be further classified into more categories like chemical processing, space exploration and disaster relief.

- **Military applications:** In this for successfully sensing the military, sensors are applied over the network. Wireless sensor network is a very likely sensing technique for military command, control, computing, communications, intelligence, surveillance, nuclear, etc. These types of networks are used to detect and access maximum information about the enemy.
- **Environmental applications:** Environmental Conditions: WSN can be used for environmental monitoring such as the movement of animals and monitoring the varying environmental conditions that affects crops and livestock. Some other applications are forest fire detection, volcanic monitoring, biological, pollution study, etc.
- **Healthcare applications:** Body sensor network is one of the most common wireless sensor network technology which provides a lot of solution to healthcare biggest challenges like an aging pollution, rising healthcare cost, interfaces for disabled, integrated patient monitoring etc. The tracking and monitoring of doctors and patients inside the hospital can also enabled by installing a small sensor. The nodes of light weight sensor are attached to the arm of patient which detects their heart rate and blood pressure.
- **Home application:** Nowadays technology is very advanced. It is possible to embed the tiny sensor nodes in the appliances by which they are capable to communicate with each other as well as to the room server to get information about the services they have to perform.
- **Traffic control:** WSN infrastructure facilitated the integration of monitoring and management operation such as signpost control, etc. With the use of wireless sensor network it is possible to monitor the road works as well as accidents.

### 1.2.8 Wireless Sensor Networks vs. Wireless Ad-hoc Networks

There are various techniques from wireless Ad-hoc Network that are still applicable in wireless sensor network. But still there are many protocols that are used in wireless ad-hoc network are suitable for wireless sensor network due to its unique features and application requirements. There are some basic differences that laid out the

foundation for new protocol for wireless sensor network. Some of the important differences are described as follows:

- The nodes in wireless sensor network are in huge numbers as compared to the nodes in wireless ad-hoc network. A typical sensor network may contain thousand of sensor node and the number of nodes goes on increasing according to the need of applications so there is an issue of scalability.
- It is impossible to assign addresses to the sensor nodes in sensor network. A Sensor networks is data-centric instead of address centric network. The main focus of sensor network is to collect data not on a individual sensor node. So it requires an collaborative efforts to collect data
- The nodes in the mobile ad-hoc network are much expensive than sensor network. A sensor node has less computation power and memory size than a node in mobile ad-hoc network.
- The nodes in an ad-hoc network communication with each other in point-to-point way whereas as the nodes in sensor network communicates in broadcast paradigm.
- A sensor network measures the changes in environment so the events in sensor network are environment-driven. Traditionally data in ad-hoc network is generated by humans. The sensor network generates when there is sudden change in the environment. Sensor networks are used to gather information whereas MANETs (Mobile Ad-hoc Networks) are developed for distributed computing.

## **1.2 Routing in wireless sensor network**

The nodes in the wireless sensor network are deployed at inaccessible location, so different routing protocol have been proposed over a period of time for the routing the packets in wireless sensor network. The routing protocol for the sensor nodes depends upon the type of application. The routing protocol in wireless sensor network is broadly classified as cluster based routing, single path routing, Multipath routing. The routing protocols in the wireless sensor network have to meet a strict power saving

constraint. The main goal for the routing protocol is to deliver the packet from source to destination based on the topology or position addressing. If the addressing is host based then it is called as topological addressing and if a unique identification is chosen for the addressing of node then it is called as position based. The sensor node is capable of delivering the requested user query back to the base station. The routing protocol for wireless sensor network can further be classified as single path algorithm in which only one instance of packet are sent at any time. There are many other protocols for wireless sensor network such as partial flooding and multipath routing. The single path routing protocol algorithm uses resources less than the resources used in multipath or partial flooding routing. The delivery of data is the main aim for single path, multipath and partial flooding routing protocol. The channel access problem is the main problem that is faced by the routing protocol. The routing protocol guarantees to access the channel efficiently by the user to increase the throughput of network. The routing algorithm used the concept of memorization of past traffic to increase the reliability of network.

- **Energy Efficient Routing:** As the energy consumption for performing computation has been significantly increased in present days but battery lifetime has not improved considerably. The signal strength adjustment consumes large amount of energy. The energy efficient routing protocol is necessary to reduce the energy consumption problem both in channel activation and data transfer.
- **Planner Graph Routing:** If the neighbors are not closer to the target and the packets are dropped by the used path. Data recovery scheme is used to recover the data. It resends the data and provides end to end delivery of packets. The use of planner graph routing increase the efficiency of network.

### **1.3.1 Routing Challenges and Design Issues**

Depending upon the application there are several challenges in the wireless sensor networks that affects the performance of the routing protocol. Some of the challenges and design issues are as follows

- **Node Deployment:** In WSN motes are deployed according to the demand of the application. Thus affects the productivity of the routing protocol. The

nodes are deployed in uniform way or randomized way. In uniform way, the nodes are placed manually at fixed spot and routing paths are predetermined. In randomized way, the nodes are scattered randomly. This causes several issues such as optimal clustering, coverage etc. The position of the sink node or cluster head is an important factor in terms of energy efficiency.

- **Energy Consumption:** Sensor nodes are small in size so they have limited power supply to perform sensing, processing and transmitting the information via a wireless communication. The lifetime of the sensor node is totally dependent on the battery. Once the battery is depleted the sensor node will be dead it causes change in topology rerouting of data. The multi-hop communication consumes less energy than direct communication. But it increases the overhead on the topology management and MAC. Direct communication is better when nodes are close to the sink node.
- **Fault Tolerance:** A fault can occur in a node due to depletion of power supply, physical damage etc. If a sensor nodes stops working it should not effects the overall working of the WSNs. Routing protocol must be capable of handling the failure of sensor nodes by accommodating new link formation , routes to the base stations and by adjusting the transmit and receiving power on the link to reduce the energy consumption
- **Network Dynamics:** For most of the application the sensor node are stationary but according to the need of the application the base station and sensor node are mobile. Routing becomes a challenge due to the mobility of nodes. According to the need of application the sensing phenomenon can be static or dynamic. Dynamic sensing is done target detection application while forest alert application requires static sensing.
- **Data Delivery Models:** The Data Delivery models depend upon the application of the network. There are four types of data delivery models: continuous, event driven, query driven and hybrid. In continuous the data is send periodically to the sink. In event driven the data is transmit when the event happens. In query driven the data is transmit when sink generates a

query to the node. Hybrid use combination of all three models depending upon the need of application.

- **Scalability:** A large number of sensor nodes in range of thousands are deployed in sensing area. Scalability means that the routing algorithms should work efficiently with large number of sensor nodes. Routing protocol must be efficient to react to the event occurring in the environment. Most of the sensor node remains in the sleep state until event does not occurs.
- **Data Aggregation:** Sensors nodes generates huge amount of similar packets, data aggregation is used to reduce the transmission of similar packets. Data aggregation is combination of information from different sensor nodes by applying functions like suppression, average, maximum. The routing protocol incorporates this data aggregation technique to reduce data redundancy and achieve energy efficiency.
- **Node capabilities:** According to the demand of application different functionalities can be given to the sensor nodes. Depending on the application a sensor node can be perform functions like sensing, relaying, aggregation etc. By performing the different functionalities by the node at the same time the energy can be depleted quickly.

#### **1.4 Problem Statement**

In wireless sensor network energy efficient is a big area of concern. Problem can be stated as to design an energy efficient technique for wireless communication in sensor nodes. In wireless sensor network the motes are scattered randomly, uniformly across the network. The base station is situated at the fixed position and has an unlimited power backup. The nodes communicate with each other and send the data to the base station. The nodes use the fusion technique to fuse the data into one packet and send the packet to the base station. The communication is energy consuming process. To overwhelm the energy problem different methods are developed in which the relay node collect the data from the sensor nodes and transmit that data to the base station, which improves the number of rounds and life time of the network. The lifetime of network can be defined as the no. of rounds a particular node can survive with its power backup. In first technique, a relay node is fixed at a particular location and a

minimum spanning tree is created using multiple parameters from the nodes to the relay node are created after every round. If the threshold energy of the node is less than or equal to dead energy the mote is removed from the network. In second technique the fixed numbers of relay nodes having energy greater than the sensor nodes are used and clusters are formed according to the distance from the relay node and the cluster are selected on the basis of multiple parameters.

## Chapter 2

### Literature Survey

---

The most important issue that affects the working of wireless sensor network is the distribution of energy load between the sensor nodes. Therefore, it is necessary to manage the balance of energy load between the nodes in the network to increase the life time of the network. LEACH [1] is a hierarchical cluster based routing protocol in which nodes are organized as clusters and cluster head is selected and randomly rotates in the clusters for better distribution of energy load between the nodes in the sensing area. In this protocol instead of direct transmission the nodes send the information to the cluster head and cluster head aggregates the information and send it to the base station. The sensors are low-energy device thus the cost of transmission between the sensor node and base station is high. Therefore LEACH use automated method of data fusion and data aggregation. LEACH is 8 times more efficient than direct transmission. In 2002 S. Lindsey et.al proposed a protocol known as PEGASIS [2] that is an improvement of LEACH protocol. Instead of making multiple clusters it forms chain like structure of sensor nodes by following greedy method. Each node sends and receives data from neighbors and there is one node that is selected to transmit the base station. Data fusion is done at all the node except the last node. Once a node in a chain is dead the new chain is formed using greedy method to bypass the dead node.

TEEN [3] is a hierarchical clustering protocol. After the cluster formation the cluster heads set the two threshold values: hard threshold value and soft threshold value. The node continues sensing the attribute of the environment but does not transmit the value until the attribute value is beyond the hard threshold value. This way number of transmission are reduced the node does not transmit until the value is in range of interest. The numbers of transmission are further reduced as the sense value is greater than the hard threshold value the node can transmit only when the value of that parameter changes by an amount at or greater than soft threshold value.

Tan [4] proposed a protocol that performs a minimum spanning tree based routing scheme The MST is made using prim's algorithm. Ossama Younis and Sonia Fahmy

presented HEED (Hybrid Energy Efficient Distributed clustering) protocol [5]. In this protocol there are two parameters for selecting the cluster heads: primary parameter is node residual energy and secondary parameter can be a node proximity or node degree. Heed is terminated in  $O(1)$  iterations. Siva D. Muruganathan *et.al* proposed a centralized routing algorithm known as BCDCP [6] that evenly distribute the energy dissipation to sensor node to improve the network lifetime. In BCDCP the high energy base station performs all the task such as forming clusters, routing paths, randomly rotate the cluster heads and do all other energy-related tasks. The main goal of the BCDCP to form balanced clusters, uniform deployment of cluster head and perform multi-hop communication between the CHs and base station. In 2007 Wen-ya Zhang *et.al* adopted a K-means clustering algorithm to determine the clusters in a WSNs in their routing protocol [7]. The cluster head is selected on the basis of location and energy information. The nodes are deployed randomly some nodes are closer to each other so this protocol keeps one node in awake state to sense the environment and this node send data to the cluster head while other nodes remains in the sleep state. This way energy consumed in communication is minimized.

Fan Xiangning *et.al* modified the cluster head selection procedure of leach protocol [8]. The selection criteria for the cluster head is based on the residual energy in the next round. In first round all the nodes have same probability of becoming cluster heads. Clusters heads are selected randomly. After the first round all the nodes have the different residual energy. The nodes having more residual energy is selected as the cluster heads in the next round. NHRPA [9] is a routing protocol that do routing according to the distant between the node and the base station, residual energy and density of nodes distribution. In NHRPA the sensing area is divided into field: one contains the sensor node in transmit range of base station and second field contains the sensor node that are not in transmit range of base station, The node in the first field directly send the data to the base station. And in the second field clusters are formed and cluster heads are selected on the basis of current energy and initial energy. The time and space complexity of NHRPA is  $O(N^2)$  where  $n$  is the number of node. This protocol is more efficient than other simple hierarchical clustering algorithms.

In 2008 Fu Wen use multi-hop communication mode between cluster-head and sink as compared to 2-hop communication mode in LEACH protocol [10]. In LEACH

there is direct communication between sink and cluster head. The base station is located at far distance from the cluster head, the energy consumption will be more, the cluster head will be dead soon. This protocol finds an optimal path between the cluster head and base station. The cluster head sends the data to the cluster head which is nearest to the sink. In 2008 Guan Xin *et.al* raises a new concept of backup cluster head to improve the fault-tolerance of the network [11]. In this protocol every clusters consists of two cluster heads: one is primary cluster head which perform its task accordingly and second is backup cluster head. Backup cluster head acts as a cluster head when the primary cluster is dead or run-out of energy. The primary cluster head and backup cluster head is determined on the basis of distance between the sensor node and centre of the cluster. The node which is nearest to the centre is primary cluster head and the node that is second nearest to the centre is backup cluster. After the data aggregation is completed at the cluster head. The cluster head sends the aggregated data to the base station using a multi-hop communication process.

DDAR [12] solves the problem energy consumption due to far distant located CHs from the base station. The protocol selects the cluster heads on the basis of node distance and energy. The number of cluster heads are not fixed and selected dynamically. The protocol calculates the average distance between the nodes from the base station. If the nodes are located far away from the average distance are not elected as cluster heads. It introduces the concept of SCH nodes. An optimal path between the cluster heads and SCH nodes are formed using MST. All the cluster heads sends data to the SCH and SCH transmit data to the base station. H.Fariborzi proposed a novel light-weight routing protocol called as EAMTR [13]. In setup phase multiple trees are formed according to the need of network traffic. The node chooses a less congested path to the base station. This protocol improves the balance of the workload for data aggregation and single-point failure for high density wireless sensor network. In 2009 Akramul Azim *et.al* introduces a concept of relay node [14]. The relay node are deployed randomly in the network. Relay node are selected as cluster heads. And transmit the data to the base station. In this way energy loss of sensor node as cluster heads communication is solved. If the relay node is dead the network continues working until last node is dead by reforming clusters.

Liu *et al.* have presented a new vehicular clustering scheme based on old routing algorithm, which is known as multi-layer clustering routing algorithm (MLCRA) [15]. Therefore MLCRA is proposed to remove the hotspot problem in WSN and results shows much improvement in network lifetime and load balance as compared with the classical algorithms like direct transmission, LEACH. In MLCRA, lower-level clusters use direct transmission to transmit the information and the top-level CHs use multi-hop communications to transfer the information to the base station. EMHR [16] is a hierarchical routing protocol that uses single-hop communication between sensor nodes and cluster-head, and multi-hop communication between the cluster heads to the base station by using the weight function. In 2010 Jae-Young Pyun presented a new hierarchical routing protocol, distance aware intelligent clustering protocol (DAIC) [17]. In this protocol the network area is divided into tiers and the node with high energy and nearest to the base station is selected as the cluster head. The number of cluster head is calculated dynamically to get rid of the unnecessary selection of the huge number of CHs in the network. The sensor node adjust the transmit power according to the distance from the base station. This distance aware method can also be used in other hierarchical protocol to improve the energy efficiency. A new approach called Data Fusion has been used with Gauss membership function [18]. The gauss function is used to improve the data precision decision and maintain the stability of network. In 2010 Gao yang *et.al* proposed an improved genetic algorithm for WSNs [19]. In FRGA a filter and replenishment method are used to increase the performance of the network and solve the problem of localization. Results show the localization accuracy by using genetic algorithm.

Jalel Ben-Othman and Bashir Yahya [20] presented an energy efficient and Quality of Service(Qos) aware routing protocol that increases the lifetime of the network by balancing the energy usage across nodes, utilize the technique of service differentiation to let the delay sensitive data to reach the base station within an sustainable delay, minimize the end to end delay by sending the data through multiple paths and uses the data redundancy to maximize the throughput. This protocol uses the parameter like residual energy, SNR and available buffer size of node to guess the next hop in path construction phase. This protocol make use of queuing model to deal with real-time and non-real-time traffic.

R.Saravanakumar *et.al* proposed a new routing protocol that on the basis of residual energy form the clusters and elects the cluster-heads from nodes in network [21] . This protocol uses the node scheduling scheme (ACTIVE and SLEEP mode).According to this node scheduling technique in every cluster of the network, according to the no. of nodes half of the nodes are kept in active mode whereas the remaining half nodes are in the sleep mode for certain time period. After the certain period of time the mode of the nodes changes, now the active nodes goes into sleep mode and the remaining half nodes goes into active mode. By applying this node scheduling scheme the energy efficiency is increased because whenever the node is in sleep mode in every cluster it consumes very less energy. Due to changing of sleeping and active modes increases the number of total rounds and the energy is distributed in a balanced way. . Mu Tong and Minghao Tang modified the procedure for selecting the number of cluster heads [22]. In leach protocol At every round after the first selection of cluster head according to LEACH[1], in second the number of cluster head are selected on the basis node's residual energy. The results show that number of cluster heads are constant and near optimal per round.

Yuhua [23] introduce the connectivity density value in the threshold function for selecting the cluster head in LEACH [1] protocol. It increases the probability of sensor node with large connectivity density to become the cluster head. In clustering stage the cluster head fixed the cluster radius according to the distance from the base station and degree of connectivity. The remaining sensor node joins the cluster on the basis of head node energy and distance from the cluster head. Also multi-hop communication is used to transfer data to the base station. Yun Li *et.al* increase the performance of LEACH protocol by setting the time length parameter for each round and increase the throughput and efficiency of network [24]. Every time a sensor node is dead the algorithm defines a new time for each round. The numbers of frames in a LEACH protocol are deducted to increase the reliability of the network. Q-leach [25] is an efficient routing protocol for wireless sensor network. The Q-leach technique uses the Q-DIR protocol and cluster approach for increase the overall life cycle of network .Quadrant based directional routing which merged the parameters called localization, flooding. With Q-dir as a reactive protocol and consumes minimum energy and increases the network efficiency.

LEACH-N [26] is an energy efficient protocol for WSNs. In this protocol the problem of selecting the cluster head nodes are solved. This method can guarantee that the cluster heads are selected based on the residual energy of the nodes in a cluster. The results show low energy consumption and better data transmission over the network. This protocol limits the energy of a node to become a cluster head node, so that the average energy of cluster and whole network is increased. CELRP [27] is a routing protocol that divides the network field into four quadrants and each quadrant consists of two clusters. The cluster head is determined on the basis of maximum residual energy and minimum distance to the base station. CELRP is a multi-hop routing protocol. Arezoo Yektaparast *et. al* proposed a algorithm that divides the cluster into 7 subparts known as cell and a node from each cell is selected as a head of the cell [28]. The cell head acts as relay node between sensor node and the cluster head. The technique for selecting the cluster head and the cell head is same. For the first time cluster head and the cell head are selected dynamically. After that they are selected on the basis of residual energy. Ningbo proposed a method to choose relay node between the cluster heads and the base station to reduce the energy consumption of the cluster head to send data directly to the base station [29]. The cluster head directly sends the data to the base station and base station is far away from the cluster head so more energy is consumed to send the data. Now cluster head does not directly send the data to the base station. All the cluster heads sends the data to the relay node, relay node aggregates the data and sends the aggregated data to the base station. Using this technique considerable amount of energy is saved through communication process. Selection criteria for relay node is based on the residual energy and distance from the base station

Dali Wei proposed a protocol to solve the problem of the node depletion in the locations where traffic load is heavy [30]. The problem is common for data aggregation scenarios where CH have a heavy load of collecting and relaying information. The relay load on CHs increases as the distance to the base station goes on decreasing. To maintain the balance of data load and the energy usage in the network, the CH should be rotated around all nodes and the size of the clusters must be deliberately decided at different location of the network. The protocol finds out the cluster sizes on the basis of distance between the hop and the base station, thus achieve approximate equalization of node lifetimes and minimize the energy usage.

In 2012 S.H. Gajjer proposed a new method to elect the cluster heads [31]. In this method cluster head is selected on the basis of multi-parameter such as residual energy and the distance from the base station. To make this protocol more energy efficient the protocol proposed a threshold values for start the steady state operation of sensor node. If the sensed value is greater than the threshold value the sensor node transmit the data to the cluster head otherwise it remains in sleep state. The threshold value is set by the user according to its needs. C-sec [32] protocol reduces energy dissipation by solving security related overhead. C-sec protocol uses simple mathematical operation to combine the security related data of two packets. C-sec eliminates the energy usage required to send security related data. C-sec also reduce the cost of protecting against replay attacks by providing a unique security property to high packet header information. BERR [33] is a routing protocol in which a node before transmitting data to the base station, estimates the hop count, energy cost value to the base station by the information gained through neighbor nodes. BERR takes into consideration the sender' energy level but also that of its adjacent nodes, so more efficient energy conditions a node has that further increases the chance of node to be selected as cluster head. BERR improves the real time delivery by choosing the node with smaller hop count to the base station as a relay node.

Do sung Kim and Hyun soo Cha proposed the FZ-Leach protocol to improvise the existing Leach protocol [34]. In this protocol the clusters is divided into two areas depending on the distance between Cluster Head and Cluster Member Node. A Far-Zone area is a group of sensor nodes that is far away from Cluster head. In this protocol Far- Zone is decided by average minimum reach ability power (AMRP). The AMRP is a measure of the expected intra cluster communication energy consumption for communication to cluster head. A cluster head computes the minimum power level of member nodes with a cluster head and the minimum power level below considered in Far-Zone. Now the powerful node is selected by the zone head residing in Far-Zone. For the selection of zone head don't consider the distance between zone head and Far-Zone Member node.

Sudhanshu Tyagi proposed a technique to improve the lifetime of the network [35]. The nodes are randomly deployed in the sensing area so some nodes are closer to the base station or far away from the base stations. In this method the nodes which are

closer to the base station can directly communicate to base station & the nodes which are far away from the base station can communicate through cluster head. The nodes that are closer to the base station does not required to form clusters as energy is consumed more as compared to direct communications. A threshold value is selected on the basis of distance with ratio of 1:9 between direct communication and cluster based communication. GEERP [36] consists of three parts: grid partition, cluster heads selection and multi-hop communication. In grid partition the network is divided into two levels: secondary level grid (SG) which forms one cluster with cluster head and primer level grid(PG) is made up of nine SGs. For every round the cluster head is selected on the basis of residual energy and the fused data of the cluster head is send to the sink node through multi-hop routing by calculating minimum weight. The result shows that it can improve the balance network energy dissipation and coverage.

Asha Ahlawat[ 37] proposed a new protocol to enhance the lifetime of the network. In this protocol along with cluster head a vice cluster head is selected on the basis of multiple parameters such as minimum distance, residual energy and minimum energy. The other node determines it cluster based on the receiving signal, greater the signal strength means less distance between the node and the cluster head so less transmission energy is required. Vice cluster head will replace the cluster head as cluster head dies. TERP [38] routing protocol emphasize on increasing the security level in the network and thus minimize the energy consumption by introducing the concept of trust factor. As the trust between the nodes is higher, less encryption of data is required and thus energy is saved. This trust factor is calculated on the basis of the importance of the data to be send. Qain Liao optimizes the threshold function for the selection of cluster head by considering the two parameters such as node's residual energy and its position information [39]. This algorithm also improves the optimal cluster head election technique i.e. is the sensor nodes elect the optimal cluster head on the basis of the cost function. Dilip Kumar have presented two novel clustering based protocols, Single-hop energy efficient Clustering protocol(S-EECP) and Multi-hop energy efficient clustering protocol (M-EECP) [40].In S-EECP the cluster head is selected on the basis of ratio between residual energy of each sensor node and average energy of the network. In M-EECP the cluster head transmit the aggregated data to the base station through multi-hop communication.

## Chapter 3: Network Design

---

### 3.1 Design Terminology

The model consists of different components as described below. It deals with various aspects of network like sensor nodes, environments, energy consumption and different notations.

**WSNs:** Consider a network consisting of  $N$  number of sensor nodes which are stationary and a fixed base station BS. Nodes are arranged randomly and uniformly in a sensing field but the base station is far away from the sensing field. The sensor nodes communicate the data to base station after sensing the environment. Data transmission takes place through multiple sensor nodes which are also referred as relay nodes.

**Base Station:** The base station has central processing unit with high computation power, a memory unit out of which small memory is used for storing the data and an unlimited power source. It collects data from the sensor field and sends to the external network. The base station communicates with outer world through internet etc.

**Node:** Each node has many sensors which sense the environment through different parameters, receiver receives data from neighboring nodes and transmitter is used for data transmission to the other nodes. Sensor nodes sense the analog signal and convert it into digital form with the help of converter and by using transmitter it transmits the data. The node consists of attributes like Node ID, unique for every node, initial energy of a node and many fields.

**Node Energy:** Energy can be distributed homogeneously or heterogeneously in a field. Every node has some initial energy  $E_0$ . After every transmission, consumes some amount of energy. The nodes with insufficient energy are completely removed from the network and new Minimum Spanning Tree is generated automatically after completion of a round. In mostly cases the heterogeneous energy is divided into two parts, one is for sensor nodes and other for relaying nodes.

**Fusion:** Every sensor node generates a b-bit packet and sends it to the neighboring node to relay the packet further to base station. All the relaying nodes compress the packet and transmit it to the base station. Data fusion technique is used by many nodes to send same packet to collector node. So, there is need of removal of duplicate packets.

**Sensing Field:** It is a rectangular field in which sensor nodes are placed randomly for communication.

**Analog to Digital Converter:** It converts the analog data to digital form after triggered an event.

### 3.2 Energy Model Used for WSNs

For our work the radio model used is same as discussed in LEACH [1]. In this model radio consumes energy to run the circuitry of transmitter and receiver and is given by  $E_{elect}=50\text{nJ/bit}$ .  $I_{amp}=100\text{pJ/bit/m}^2$  is required for amplification of the transmit signal. In order to transmit a message of n-bit over a distance d the cost of transmission ( $E_{TX}$ ).

Cost of Transmission

$$E_{TX}(n, d) = n * E_{elect} + n * I_{amp} * d^2 \quad (1)$$

$$E_{TX}(n, d) = n * E_{elect} + n * I_{amp} * d^4 \quad (2)$$

To receive a message the Cost of Reception ( $E_{RX}$ ) is

$$E_{RX} = E_{elect} * n \quad (3)$$

There is an assumption in this model the energy required to send data from node A to node B is same as energy required to send data from node B to node A for a given SNR ratio. To transmit a message over a short range distance such as between the sensor node and the cluster head the energy dissipates by the transmit amplifier is directly proportional to  $d^2$ . However for a long range distance such as between the cluster head and the base station the energy dissipates by the transmit amplifier is directly proportional to  $d^4$ . The cost of transmission and reception for a message is high, so the protocol must try to minimize the transmission distance and the number

of transmit and receive operation required for sending a message. The following figure represents the radio model.

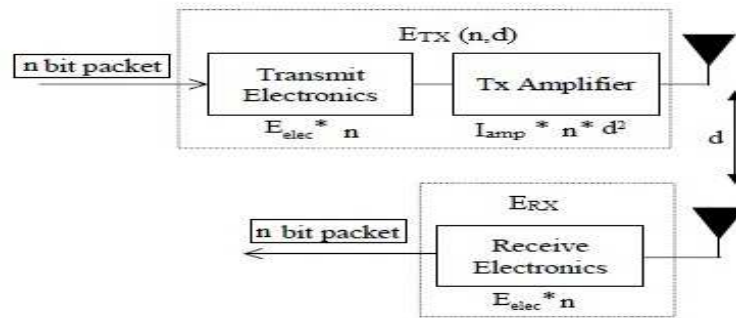

Figure 3.1: Radio model

### 3.3 Deployment Methodology

The network model consists of multiple sensor nodes and a single base station. The 100 nodes are scattered randomly over the sensing field of  $60*60m^2$ . Each node in the sensing field has an ability to transmit the data to the base station directly but this direct transmission consumes a lot amount of energy. To reduce the energy consumption multi-hop routing is used for increase the life cycle. In MAEE protocol a concept of relay node are used in which on relay node is in fixed position (45,45) and distance is calculated from this point. The link cost is calculated by using cost estimation function after that the best path is chosen by using multiple metrics and then the data is send to the base station. In MCBA protocol a multi-objective cluster based approach is used in which clusters are formed from a fixed point and cluster head are elected on the basis of multiple parameters. The following figure shows the random deployment of nodes in  $60*60m^2$ .

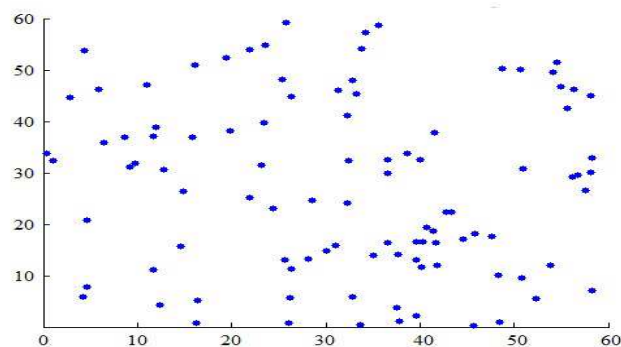

Figure 3.2: Random deployment

### 3.4 Sensor and Relay Node Information

The node structure consists of number of fields such as location of the nodes, UID, Distance from close relay node, Distance from base station, Initial energy, Available Energy, Threshold Energy and Dead Energy. By using these fields the nodes can communicate with other nodes and a fixed position base station. The values of some of these fields are change after the completion of each transmission. The following figure show the number of fields used in node structure.

LOCATION OF NODES	UID	DISTANCE FROM RELAY NODE	DISTANCE FROM BS	INITIAL ENERGY	AVAL ENERGY	THRESH ENERGY	DEAD ENERGY

Figure 3.3: Node structure

Where the location of node is used to finds its location in the sensing field as shown in coordinate system. UID is a unique identification number assign to each node for addressing purpose. Distance from close relay node is used to form the cluster and select the cluster head node. Every node have some amount of initial energy and each round when transmission is done the transmission energy is reduce from the initial energy of that node and stored in available energy field. Threshold energy and Dead energy are used to continue the transmission, when the available energy is equal to threshold energy then node is consider to be dead and when threshold energy is equal to dead energy then network is consider to dead.

### 4.1 Cost Estimation Function

The cost function is used in protocols is to estimate the link cost based on the multiple parameters. The cost is used to find the best path and cluster head in case of MAEE protocol and MCBA protocol respectively. For increase the lifetime of network and make the network reliable the cost estimation function used are shown below.

$$C_{link} = C_D * \frac{D_{hop}}{D_{req}} + C_E * \frac{E_{req}}{E_{node}} \quad (4)$$

Where  $C_D$  and  $C_E$  are the cost factor for energy, delay respectively as defined in three classes as shown in table 1.  $D_{hop}$ ,  $E_{Node}$  are the delay of link and energy of node respectively.

Table 1: Classes for path selection

CLASS	Parameters	$C_D$	$C_E$
10	Delay	1	0
01	Energy	0	1
11	Delay and Energy	0.5	0.5

In our work , the class 3 is used for selection of best path and cluster head in the proposed protocols. The value of  $C_D$  and  $C_E$  are 0.5.

### 4.2 Link Cost Function

The link cost function consists of two parameters one is transmission energy that is used for transmission of packet from one hop to another hop and second is delay are distributed randomly in a range of 1-20ms over the network. We use the idea of greedy method to forward the data to the base station. The sender sensor node search its neighbor by using the concept of radio model is described as section 3. The node that is nearest to the source node is elect as next hop for communication because if distance between two hops is less than lesser energy is used for transmission and receiving of packets. The same process is repeat to identify the path to base station. The expected formula used for finding the cost of link as follow

$$E_{TX}(n, d) = n * E_{elect} + n * I_{amp} * d^2 \quad (5)$$

$$E_{TX}(n, d) = n * E_{elect} + n * I_{amp} * d^4 \quad (6)$$

Where  $d$  is the distance from one hop to another,  $E_{elect}$  is the energy for start the circuitary and  $I_{amp}$  is the amplification energy and  $n$  is the number of bits of packet. The packet format used for communication in which  $E_{min}$  or threshold energy value is shown in path parameter field and  $D_{path}$  also shown in path parameter field. The following figure shows the packet formation used for transmission of 2000 bit packet over the network.

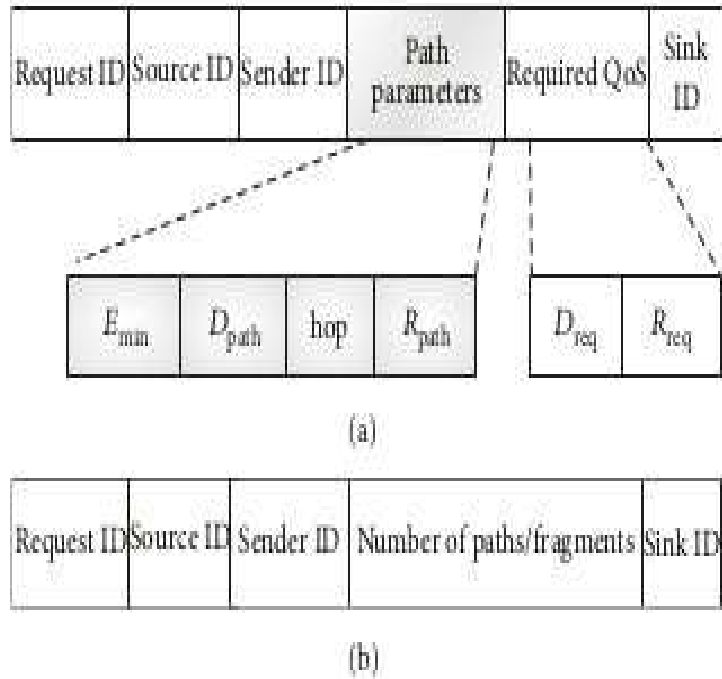

Figure 4.1: Packet Format

### 4.3 Multi-objective Approach for Energy Efficiency (MAEE)

The model consists of two parts

- Minimum Spanning Tree
- Cost estimation function

In this architecture by using the greedy approach a minimum spanning tree is constructed by using two parameters delay and transmission energy. With the help of

cost estimation function link cost is assign to each sensor node. The link cost use the value of  $C_D$  and  $C_E$  is 0.5 and minimum best path is selected

The following Algorithm shows for MAEE

#### 4.3.1 Algorithm

##### **Initialization Phase**

**Step1:** Deploy the nodes randomly in a fixed size sensing field and one fixed position relay node whose initial energy is 6 Joule.

**Step2:** Calculate each sensor node initial energy, delay and assign a unique identification number.

##### **Setup and Route Discovery Phase**

**Step3:** By using the cost estimation function find the best minimal path from source sensor node to the fixed size relay node. The formula used for calculating the cost is shown in equation 1 and assign these cost values to each link.

**Step4:** Now apply the greedy approach to find the best minimal path from source to fixed size relay node go to step 5. If not then go to step 6.

##### **Energy Deduction phase**

**Step5:** If Path is available deduct the energy consumed for transmission of data from source node to relay node denoted by  $R_1$ .

**Step6:** If path is not available then the packet is drop and go to step 9.

**Step7:** Now transmission of data from relay node to BS and reduce energy consumed for flow of data.

**Step8:** If the available energy of node is less than the threshold energy then node is discarded from the network.

**Step9:** Repeat this process set the id parameter to 1 after each transmission the process is repeated until threshold value is not equal to the dead energy and the whole network dead.

Whenever a source node detect an event after that packets are send to identify the path from that sensor node to the base station. The estimate cost function and link cost function is used to estimate the cost of the link. By applying the dijkstra's algorithm an optimal path is identify for communication. The following figure shows the MAEE protocol.

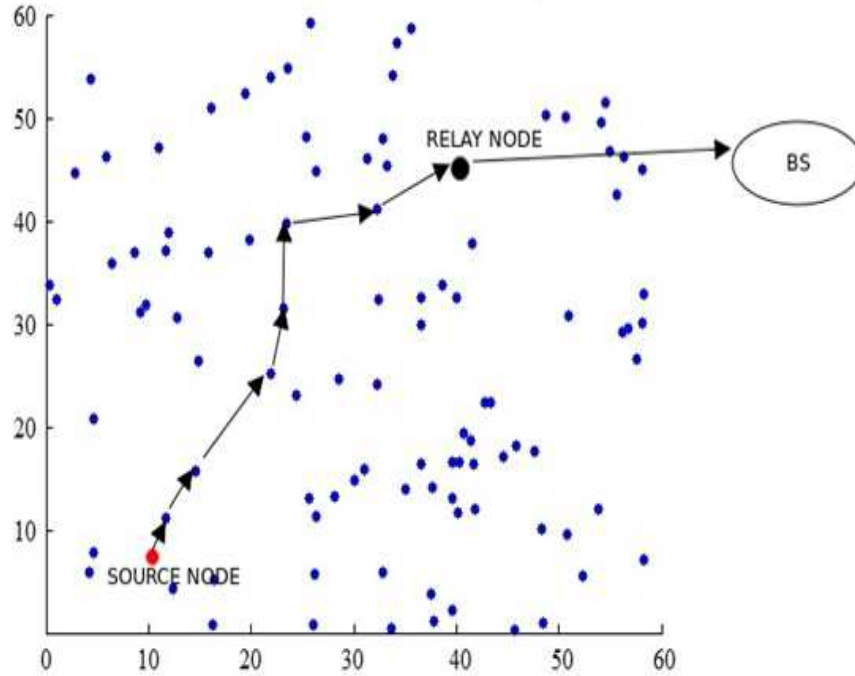

Figure 4.2: MAEE

In MAEE protocol is not send the data directly to the base station firstly all the sensor node send the data to the relay node and then the relay node send the data to the base station.

#### 4.4 Energy Deduction

After identifying the optimal route from the source node to the base station, the actual transmission can take place in every round of communication same amount of energy is reduces from hop to hop. If the distance between the two hops are larger than large amount of energy is consumed otherwise minimum amount of energy is used. Our aim is to reduce the energy consumption. The energy of relay node is much higher than the other sensors nodes. The relay nodes are fully functional device. All the other sensor nodes send the data to the high energy relay node. After that relay node calculate the distance from base station by using the equation 1 and sends the data to the base station. The formula used for deducting the energy is express as

$$E_{rem} = E_{ava} - E_{TX} \quad (7)$$

Where  $E_{rem}$  is the remaining energy of the sensor or relay node ,  $E_{ava}$  is the current available energy before the transmission of data and  $E_{TX}$  is the transmission energy consumed during the communication. The multiobjective parameters are consider for proposed protocol are as under

#### 4.4.1 Energy Consumed

The end to end energy is defined as the total amount of energy required to send the data from source node to the base station and can be expressed as

$$E_{pth} = \sum_{l=1}^{hop_n} E_{hop_s} \quad (8)$$

Where  $E_{hop_s}$  is the amount of energy consumed by single hop transmission and how much energy is consumed by single node is described in Energy model in section 3.

#### 4.4.2 End To End Delay

The delay is defined as the amount of wating time for processing queueing, transmission and propogation delay. The delay of path  $D_{pth}$  can be defined as the sum of all the delay of link on that path.

$$D_{pth} = \sum_{l=1}^{hop_n} D_{hop} \quad (9)$$

Where  $D_{hop}$  is the delay for a single link in a path. End to End delay is defined as the maximum delay for the path

$$D_{e2e} = max D_{pth} \quad (10)$$

#### 4.4.3 Packet Loss Probability

It is defined as the ratio of number of packets send by the source to the number of packets received by the receiver and can be express as

$$P_{PLP} = \frac{P_{source}}{P_{sink}} \quad (11)$$

The packet loss probability ratio for transmission of packets from source node to the fixed position relay node and relay node to base station is shown in figure 4.2.

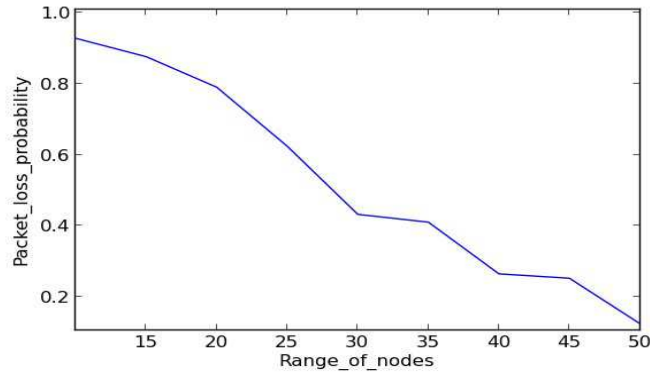

Figure 4.4: Packet Loss Probability of Network

The average energy consumption for transmission of data to BS is shown in Figure4.3

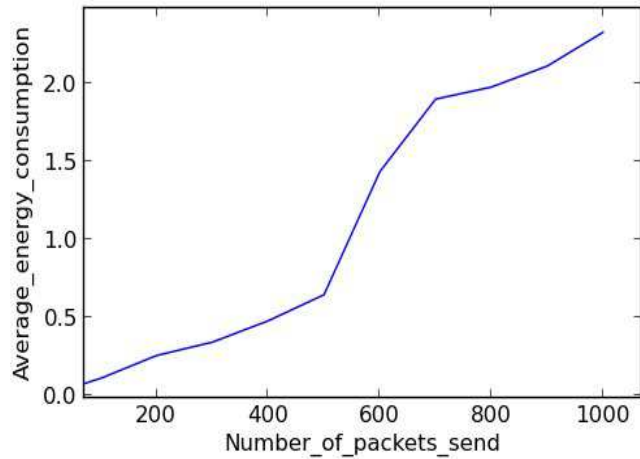

Figure 4.3: Average Energy Consumption

#### 4.5 Multi-objective Cluster Based Approach for Energy Efficiency (MCBA)

The architecture of this protocol consists of relay nodes and cluster head node. The cluster head node are chosen based on the cost estimation function and each time cluster head send the data to the closed relay node. After collect the data form cluster heads, the relay node use fusion technique to combine multiple packets in one packet and send the data to other base station via other relay nodes. The 5 percent nodes in the network are Relay nodes. The following figure represents the cluster formation in MCBA protocol.

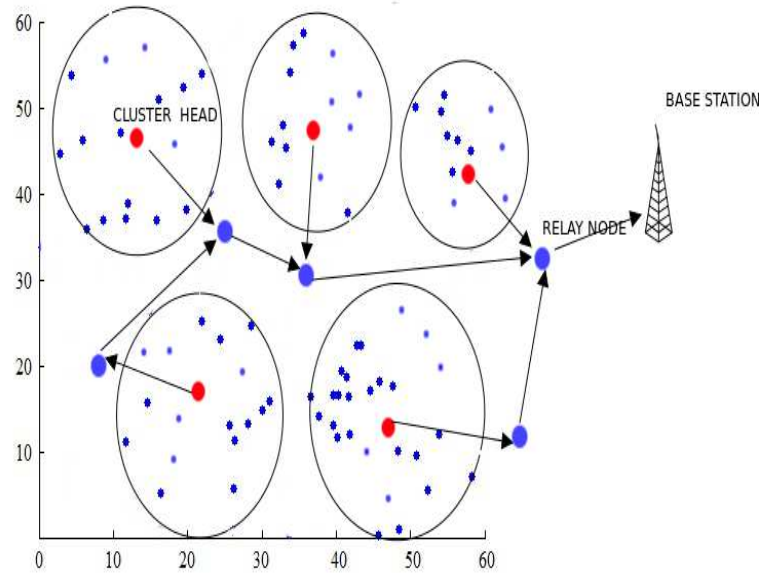

Figure 4.5: MCBA

In this technique fixed position relay nodes are placed over the network. All the sensor nodes make cluster by calculating the distance from the closest relay node. The nodes which are closest to a relay node are placed in one cluster and remaining nodes are placed in another cluster. After that a cluster head is chosen on the basis of maximum energy and minimum delay and all the clusters head nodes sent the data to their closest relay nodes. The relay nodes collect the data and send to the base station via other relay nodes. The following algorithm shows the full description of MCBA protocol

#### 4.5.1 Algorithm

##### Initialization Phase

**Step1:** Sensor nodes are deployed randomly in a rectangular plane of area  $60*60m^2$  and classified these nodes in the form of cluster by calculating distance from nearest relay nodes. The relay nodes are fixed position nodes.

**Step2:** Cost of link is calculated by using cost estimation function and assign cost value, delay and initial energy to each sensor node.

### **Setup Phase**

**Step3:** Now choose the cluster head based on two parameters with maximum energy and minimum delay. The energy of relay nodes are greater than the sensor nodes.

**Step4:** Each member node sends the data to the cluster head and reduce certain amount of energy. The nodes which have less energy than the threshold energy are considered to be dead.

**Step5:** All the cluster head nodes send the aggregated data to the nearest fixed position relay node and energy is consumed during transmission. If the energy of relay node is equal then the transmission energy the node is removed from the network.

**Step6:** Relay nodes are very far away from the base station so each node sends the data to the nearest relay node for sending the data to the base station and reduce the energy consumption.

**Step7:** If the Relay nodes are dead then a new cluster are formed and for choosing the head node go to step 3. This process repeat until the threshold value is not equal to dead energy which means the network is dead.

## Chapter 5

### Results

The simulation results of the proposed protocols are shown in a table given below. The network comprises of 100 sensor nodes i.e. are randomly scattered in a fixed size sensing field of area  $60*60m^2$  and computes the life cycle of the network. In each round of communication one or certain amount of sensor nodes are dead and these nodes are removed from the network. The MAEE and MCBA are more efficient protocol as compared with existing Leach protocol. The MAEE is 1.5x efficient and MCBA is 2x efficient than the leach protocol. In case of MAEE a one fixed node called relay node is placed at position (45, 45) and base station is located at (90, 90). Every time a minimum spanning tree is generated from source sensor node to fixed position relay node and then relay node sends the data to the base station. The initial energy of relay node is 6 joule/node. In case of MCBA a cluster are formed based on the distance from the fixed location base station the cluster head is chosen on the basis of cost function and used for the transmission of data to the relay nodes. In MCBA relay nodes are used and initial energy of each relay node is 4 joule. The following table show the lifetime of network.

Table 2: Simulation results for a 60m\*60m network with initial energy 0.5J/node

Dead Node	MAEE	MCBA	LEACH
1	1139	1800	803
2	1158	1819	812
3	1168	1838	821
4	1178	1857	830
5	1188	1876	839
6	1198	1895	848
7	1218	1914	857
8	1224	1933	866
9	1225	1952	875
10	1228	1971	884
11	1238	1990	893

12	1248	2009	902
13	1258	2028	911
14	1266	2047	913
15	1274	2066	920
16	1282	2085	929
17	1290	2104	938
18	1307	2123	947
19	1311	2142	957
20	1329	2161	964
21	1332	2180	966
22	1357	2199	968
23	1362	2218	970
24	1368	2237	972
25	1377	2256	974
26	1381	2275	976
27	1399	2294	978
28	1405	2313	979
29	1416	2332	980
30	1421	2351	982
31	1430	2370	984
32	1447	2389	986
33	1454	2408	987
34	1469	2427	988
35	1473	2446	990
36	1488	2465	991
37	1498	3484	992
38	1504	3503	993
39	1515	2522	994
40	1525	2541	995
41	1535	2560	996
42	1544	2579	997
43	1558	2598	998
44	1561	2617	999

45	1574	2636	1000
46	1582	2655	1001
47	1595	2674	1002
48	1601	2693	1003
49	1613	2712	1004
50	1626	2731	1005
51	1627	2750	1006
52	1637	2769	1007
53	1647	2788	1008
54	1657	2807	1009
55	1668	2826	1010
56	1679	2845	1011
57	1689	2864	1012
58	1693	2883	1013
59	1707	2902	1014
60	1714	2921	1015
61	1725	2940	1016
62	1732	2959	1017
63	1747	2978	1018
64	1753	2997	1019
65	1766	3000	1020
66	1771	3002	1021
67	1788	3004	1022
68	1797	3006	1023
69	1802	3008	1024
70	1815	3010	1025
71	1823	3012	1026
72	1831	3014	1027
73	1841	3016	1028
74	1853	3018	1029
75	1868	3020	1030
76	1872	3022	1031
77	1889	3024	1032

78	1898	3026	1033
79	1908	3028	1034
80	1910	3030	1035
81	1923	3032	1036
82	1939	3034	1037
83	1945	3036	1038
84	1956	3038	1039
85	1963	3040	1040
86	1974	3042	1041
87	1981	3044	1042
88	1990	3046	1043
89	2000	3048	1044
90	2002	3050	1045
91	2005	3052	1047
92	2008	3054	1049
93	2015	3056	1051
94	2020	3058	1053
95	2025	3060	1055
96	2030	3079	1057
97	2035	3082	1059
98	2040	3084	1061
99	2045	3088	1063
100	2047	3092	1065

The figure 5.1 represents the life time of network. The red and blue lines in figure show the number of packets send by MCBA and MAEE protocols respectively. The x-axis represents the number of nodes dead in every single round and y axis shows the lifetime of network.

The first node dead after the transmission of 1139 packets in case of MAEE and 1399 in case of MBCA. The last node is dead after the transmission of 2047 and 3082 packets in case of MAEE and MBCA. All the remaining sensor node having initial energy is 0.5j/node and base station have limited amount of energy.

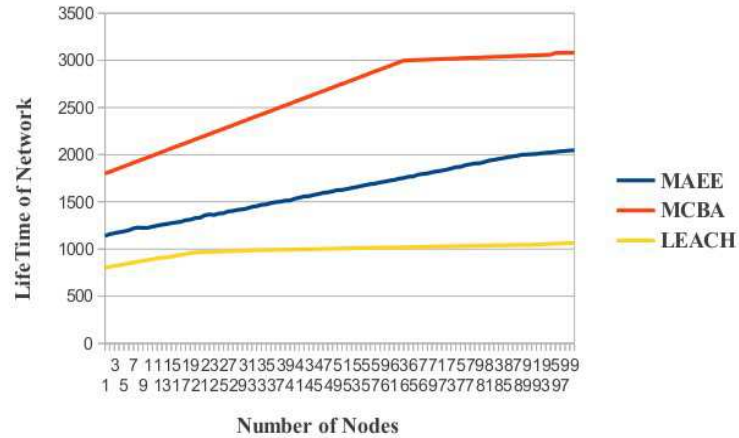

Figure 5.1: Simulation Results for lifetime of network.

The dead energy for the network is 0.003j/node. In MAEE protocol a relay node whose initial energy is 6 joule is placed in fixed location (45,45) and base station is at (90,90) in coordinate system of sensing field. Every time a optimal path is identify from source to relay node and after that actual transmission to base station can take place via relay node. In case of MBCA cluster are formed from closest relay nodes which are at fixed position in the networking field. The cluster head send the data to the closest relay node which forwards the data to the base station via other relay nodes. The relay node energy in MBCA protocol is 6 joule/node.

The table 3 shows the inputs parameters for transmission of 2000 bits message over the network.

Table 3: Requirements

1	Initial Energy	5 joule
2	Initial Relay Energy	6 joule
3	Packet size	2000 bits
4	Range	25 m
5	$E_t$	5 nj/bit
6	$E_{amp}$	100 pj/bit/ $m^2$
7	Number of nodes	100
8	Area	60*60 $m^2$
9	Dead Energy	0.003 joule
10	Threshold Energy	0.25 joule
11	Position Of BS	(90,90)
12	Position of Relay Node	(45,45)

The following figure shows no. of rounds after which the first node, Half nodes and Last node is dead.

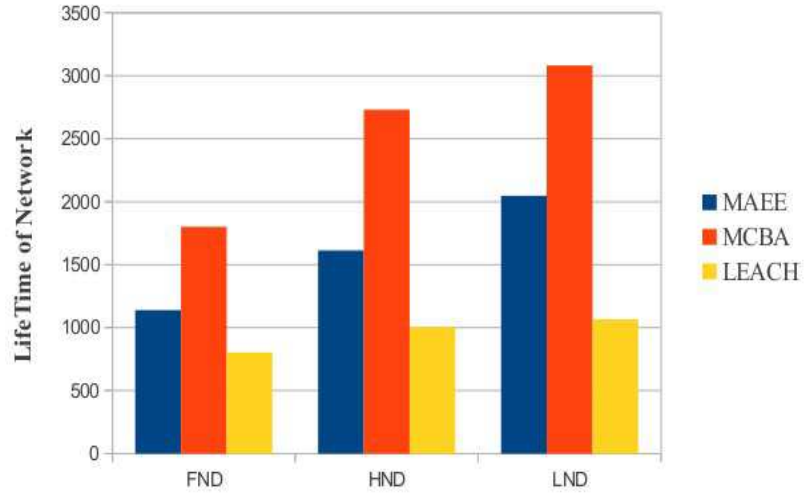

Figure 5.2: Simulation Results for FND, HND and LND.

## **Conclusion and Future Scope**

---

In this work two energy efficient protocols MAEE and MCBA are proposed to increase the reliability of the network. The simulation results show that the protocols are much better than the existing leach protocol. The energy consumption for transmission of data to Base station in both the protocol is less than the existing leach protocol. The concept of relay node and minimum spanning tree are used to increase the overall lifetime of the network.

As a future scope one can think of apply these protocol to mobile network and check the perform of network and also focus on the security issues on WSNs.

## References

---

- [1] Wendi Rabiner Heinzelman, Anantha Chandrakasan, and Hari Balakrishnan, "Energy efficient communication protocol for wireless microsensor networks," *In Proceedings of the IEEE 33rd Annual Hawaii International Conference on System Sciences*, 2000.
- [2] Stephanie Lindsey and Cauligi S. Raghavendra, "PEGASIS: Power-efficient gathering in sensor information systems," *In Proceedings of the IEEE conference on Aerospace*, 2002.
- [3] Arati Manjeshwar, and Dharma P. Agrawal. "TEEN: a routing protocol for enhanced efficiency in wireless sensor networks," *In Proceedings of the IEEE International Symposium on Parallel and Distributed Processing* , 2001.
- [4] Huseyin Qzgur Tan and Ibrahim Korpeoglu, "Power efficient data gathering and aggregation in wireless sensor networks," *ACM Sigmod Record*, Vol. 32, No. 4 , 2003 , pp. 66-71.
- [5] Ossama Younis and Sonia Fahmy, "HEED: a hybrid, energy-efficient, distributed clustering approach for ad hoc sensor networks," *IEEE Transactions on Mobile Computing*, Vol. 3, No. 4, 2004, pp. 366-379.
- [6] Siva D. Muruganathan, Daniel C. F. Ma, Rolly I. Bhasin, and Abraham O. Fapojuwo, "A centralized energy-efficient routing protocol for wireless sensor networks," *IEEE Radio Communication* Vol. 43 No. 3 ,2005, pp 8-13.
- [7] Wen-ya Zhang, Zi-ze Liang, Zeng-guang Hou and Min Tan "A power efficient routing protocol for wireless sensor network." *In Proceedings of the IEEE International Conference on Networking, Sensing and Control*, 2007
- [8] Fan Xiangning, and Song Yulin. "Improvement on LEACH protocol of wireless sensor network." *IEEE International Conference on Sensor Technologies and Applications*, 2007
- [9] Cheng Hong-bing, Yang Geng, Hu Su-jun, "NHRPA: a novel hierarchical routing protocol algorithm for wireless sensor networks," *The Journal of China Universities of Posts and Telecommunications* , Vol. 15 , No. 3, 2008, pp. 75-81
- [10] Wei Bo, Hu Han-ying and Fu Wen, "An Improved LEACH Protocol for Data Gathering and Aggregation in Wireless Sensor Networks," *IEEE International Conference on Computer and Electrical Engineering*, 2008.

- [11] Guan Xin, Wu Hua Yang and Bi De Gang, "EEHCA: An energy efficient heriarchical clustering algorithm for WSNs," *Information Technology Journal*, Vol. 7, No. 2, 2008, pp 245-252.
- [12] Navin Gautum, Won-Il Lee, and Jae-Young Pyun. "Dynamic clustering and distance aware routing protocol for wireless sensor networks." *In Proceedings of the 6th ACM symposium on Performance evaluation of wireless ad hoc, sensor, and ubiquitous networks*, 2009.
- [13] Fariborzi Hossein, and Mahmoud Moghavvemi. "EAMTR: Energy aware multi-tree routing for wireless sensor networks." *IET communications*, Vol. 3, No. 5, 2009 pp 733-739.
- [14] Akramul Azim and Mohammad Mahfuzul Islam, Hybrid LEACH: A relay node based low energy adaptive clustering hierarchy for wireless sensor networks, *In Proceedings of the IEEE 9th Malaysia International Conference on Communications*, 2009.
- [15] Y. Liu, N. Xiong, Y. Zhao, A.V. Vasilakos, J. Gao and Y. Jia, "Multi-layer clustering routing algorithm for wireless vehicular sensor networks," *IET communications* , Vol. 4, No.7 , 2010, pp 810-816
- [16] W.-W. Huang, Y.-L Peng, J. Wen and M. Yu, "Energy-efficient multi-hop hierarchical routing protocol for wireless sensor networks," *In Proceedings of the IEEE International Conference on Networks Security, Wireless Communications and Trusted Computing*, 2009
- [17] Navin Gautam, and Jae-Young Pyun. "Distance aware intelligent clustering protocol for wireless sensor networks." *Journal of Communications and Networks*, Vol. 12, No. 2 , 2010, pp 122-129.
- [18] Chen, Wei-Qi, and Bin-Jie Hu, "A data fusion algorithm in LEACH protocol using gauss membership function," *6th International Conference on. Wireless Communications Networking and Mobile Computing* , IEEE, 2010.
- [19] Gao Yang, Zhuang YI, NITmnquan, YKeke, Xue, "An Improved Genetic Algorithm for Wireless Sensor Networks Localization," *IEEE* , 2010, pp 439-443.
- [20] Ben Othman, Jalel, and Bashir Yahya. "Energy efficient and QoS based routing protocol for wireless sensor networks," *Journal of Parallel and Distributed Computing* Vol 70, No. 8, 2010, pp. 849-857.

- [21] R. Saravanakumar, S. G. Susila and J. Raja. "An energy efficient cluster based node scheduling protocol for wireless sensor networks." *10th IEEE International Conference on Solid-State and Integrated Circuit Technology (ICSICT)*, 2010.
- [22] Mu Tong and Minghao Tang. "LEACH-B: An improved LEACH protocol for wireless sensor network." *6th International Conference on Wireless Communications Networking and Mobile Computing (WiCOM)*, IEEE, 2010.
- [23] Yuhua Liu, Zhenrong Luo, KaihuaXu, Lilong Chen "A reliable clustering algorithm base on LEACH protocol in wireless mobile sensor networks." *2nd International Conference on. Mechanical and Electrical Technology (ICMET)*, IEEE, 2010.
- [24] Yun Li, Nan Yu, Weiyi Zhang, Weiliang Zhao, Xiaohu You and Mahmoud Daneshmand, "Enhancing the Performance of LEACH Protocol in Wireless Sensor Networks," *IEEE INFOCOM*, 2011, pp 223-228.
- [25] J.Gnanambigai, N.Rengarajan and K.Anbukkarasi, "Q-Leach: An Energy Efficient Cluster Based Routing Protocol for Wireless Sensor Networks," *In Proceedings of 7th International Conference on Intelligent Systems and Control*, 2011, pp 259-262
- [26] Yuling Li, Luwei Ding and Feng Liu, "The Improvement of LEACH Protocol in WSN," *International Conference on Computer Science and Network Technology*, 2011, pp 1345-1348.
- [27] Nurhayati, Sung Hee Choi, Kyung oh lee, "A Cluster based Energy Efficient Location Routing Protocol in WSNs," *International Journal of computer and communication*, vol 5, No. 2, 2011, pp 67-74.
- [28] Arezoo Yektaparast, Fatemeh-Hoda Nabavi, Adel Sarmast, "An Improvement on LEACH Protocol(Cell-LEACH)," *ICACT2012*, 2012, pp 992-996.
- [29] Wang, Ningbo, and Hao Zhu. "An energy efficient algorithm based on LEACH protocol," *International Conference on Computer Science and Electronic Engineering*, IEEE, 2012.
- [30] Dali Wei, Yichao Jin, Serdar Vural, Klaus Moessner, and Rahim Tafazolli, "An energy-efficient clustering solution for wireless sensor networks." *IEEE Transactions on Wireless Communications*, Vol. 10, No. 11, 2011, pp. 3973-3983.
- [31] S. H. Gajjar, K. S. Dasgupta, S. N. Pradhan and K. M. Vala, "Lifetime improvement of LEACH protocol for Wireless Sensor Network." *International Conference on Engineering*, IEEE, 2012.

- [32] Abidalrahman Mohd , Nauman Aslam, William Phillips, William Robertson,” A dual-mode energy efficient encryption protocol for wireless sensor networks,” *Ad Hoc Networks elsevier*, vol 11, 2013, pp 2588-2604.
- [33] Liu Zhi-xin, Dai Li-li, Ma Kai and Guan Xin-ping, “Balance energy-efficient and real-time with reliable communication protocol for wireless sensor network.” *The Journal of China Universities of Posts and Telecommunications* Vol. 20, No. 1 , 2013 pp. 37-46.
- [34] Do sung Kim, Hyun soo Cha and Seungwha Yoo, “Improve Far-Zone LEACH Protocol for Energy Conserving,” *8th International Conference on. Wireless Communications, Networking and Mobile Computing* , IEEE, 2012
- [35] Sudhanshu Tyagi, Sumit Kumar Gupta, Sudeep Tanwar and Neeraj Kumar "EHE-LEACH: Enhanced heterogeneous LEACH protocol for lifetime enhancement of wireless SNs." *International Conference on. Advances in Computing, Communications and Informatics*, IEEE, 2013.
- [36] Cunxiang Chen, Zunwen He, Hongmei Sun, Jingming Kuang, De-meng Bai, and Chenxi Yang, "A grid-based energy efficient routing protocol in Wireless Sensor Networks." *International Symposium on Wireless and Pervasive Computing (ISWPC)*, IEEE, 2013.
- [37] Ahlawat, Asha, and Vineeta Malik. "An Extended Vice-Cluster Selection Approach to Improve V Leach Protocol in WSN." *Third International Conference on. Advanced Computing and Communication Technologies*, IEEE, 2013.
- [38] Marwah Almasri, Khaled Elleithy; IEEE Senior Memembr, Anas Bushang, and Remah Alshinina, " TERP: A Trusted and Energy Efficient Routing Protocol for Wireless Sensor Networks (WSNs)," *IEEE/ACM 17th International Symposium on Distributed Simulation and Real Time Applications (DS-RT)*, IEEE, 2013.
- [39] Qian Liao, Hao Zhu, "An Energy Balanced Clustering Algorithm Based on LEACH Protocol," *Proceedings of the 2nd International Conference On Systems Engineering and Modeling*, 2013, pp 72-77.
- [40] Dilip Kumar, "Performance analysis of energy efficient clustering protocols for maximising lifetime of wireless sensor networks," *IET Wireless Sensor Systems*, vol. 4, No. 1, 2014, pp. 916.

## List of Publication

---

Onkar Taneja, Vinod Kumar Bhalla, "Novel Approaches for increasing Energy Efficiency in WSNs," *IEEE First International Conference on Networks and Soft Computing*, IEEE, (ICNSC-2014), 2014 (Status: Accepted)