

**Modeling and Simulation of a PV generator and
Maximum Power Point Tracking Controller
Using Simscape**

A Dissertation submitted in fulfillment of the requirements for the Degree
of

MASTER OF ENGINEERING
in
Power Systems

Submitted by

Rajinder Singh
(Reg. No. 801341018)

Under the Guidance of
Dr. Prasenjit Basak
Assistant Professor, EIED



2015

Electrical and Instrumentation Engineering Department
Thapar University, Patiala
(Declared as Deemed-to-be-University u/s 3 of the UGC Act., 1956)
Post Bag No. 32, Patiala – 147004
Punjab (India)

DECLARATION

I hereby certify that the work which is presented in dissertation entitled, "Modeling and Simulation of a PV generator and Maximum Power Point Tracking Controller Using Simscape", in partial fulfillment of the requirements for the award of the degree of Master of Engineering in Power Systems, submitted to Electrical & Instrumentation Engineering Department of Thapar University, Patiala is as authentic record of my own work carried under the supervision of Dr. Prasenjit Basak. It refers others researcher's work which are duly listed in the reference section. The matter contained in this dissertation has not been submitted, neither in part nor in full to any other degree to any other university or institute except as reported in text and references.

Place: Patiala
Date: 15-07-2015

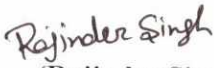
(Rajinder Singh)
Roll No.: 801341018

It is certified that the above statement made by the student is correct to the best of my knowledge and belief.

Date: 15/7/15

(Dr. Prasenjit Basak)
Assistant Professor
Electrical & Instrumentation Engineering Department
Thapar University, Patiala

Countersigned by:

(Dr. Ravinder Agarwal)

Professor & Head
Electrical & Instrumentation Engineering Department
Thapar University, Patiala

(Dr. S. S. Bhatia)

Professor & Dean
(Academic Affairs)
Thapar University, Patiala

ACKNOWLEDGEMENT

With great pleasure and privilege, I wish to express my heartfelt sense of gratitude and indebtedness to Dr. Prasenjit Basak, Assitant Professor, EIED, Thapar University, Patiala for his patient guidance and support throughout this report. I found this guidance valuable and more importantly his supportive and motivating approach.

I am also thankful to Dr. Ravinder Agarwal, Professor & Head, EIED as well as Ms. Manbir Kaur, Associate Professor & PG Coordinator for the needed support and motivational approach. I also want to express my gratitude to Dr. Sanjay Kumar Jain, Associate Professor, for his valuable suggestion and constant encouragement all through the work.

I am also thankful to the faculty of EIED for extending their cooperation. I wish to thank my friends who devoted their valuable time and helped me in all possible ways towards successful completion of this work. I thank all those who have contributed directly or indirectly to this work.

Lastly, I would like to thank my parents for their years of unyielding love and encouragement. They have always wanted the best for me and admire their determination and sacrifice.

Rajinder Singh
(801341018)

TABLE OF CONTENTS

	Page
DECLARATION	i
ACKNOWLEDGEMENT	ii
TABLE OF CONTENTS	iii
LIST OF TABLES	vi
LIST OF FIGURES	vii
LIST OF SYMBOLS	ix
LIST OF ABBREVIATION	xi
ABSTRACT	xii
CHAPTER-1 INTRODUCTION	1
1.1 Overview	1
1.2 The Different Types of Renewable Energy Resources.....	1
1.3 The Renewable Energy Trends across the Globe	2
1.4 Literature Review.....	3
1.5 Motivation.....	6
1.6 Objective of Work	7
1.7 Organization of the Dissertation.....	8
CHAPTER-2 THEORY BEHIND PHOTOVOLTAIC CELL	9
2.1 Solar Energy Conversion.....	9
2.1.1 Solar Radiation.....	9
2.1.2 Photovoltaic Cell Operation.....	11
2.2 Mathematical Equation of the PV Cell	12

TABLE OF CONTENTS (Continued)

	Page
2.2.1 <i>Ideal PV Cell</i>	12
2.2.2 <i>Construction of PV Modules and Array</i>	13
2.3.3 <i>Fill Factor of PV Module</i>	15
CHAPTER-3 MODELING AND SIMULATION OF THE PV GENERATOR	17
3.1 Description of PV Generator Model in Simscape MATLAB/Simulink Environmental	17
3.1.1 <i>Specification of the Solar Cell</i>	17
3.1.2 <i>Solar Sub-Module</i>	18
3.1.3 <i>Solar Module</i>	19
3.1.4 <i>Solar Array (PV Array)</i>	19
3.2 Simscape Based Modeling and Simulation of PV Generator to Obtain I-V and P-V Characteristics	20
3.2.1 <i>Characteristics of the PV Generator</i>	22
3.3 Results of Simulation of the PV Generator	25
3.3.1 <i>Voltage versus Time Characteristic of PV Generator</i>	25
3.3.2 <i>Current versus Time Characteristic of PV Generator</i>	26
3.3.3 <i>Power versus Time Characteristic of PV Generator</i>	27
CHAPTER-4 SIMULATION OF MAXIMUM POWER POINT TRACKER	28
4.1 Description of PV Generator Connected with DC-to-DC Converter and MPPT Controller	28
4.2 Simulation of Photovoltaic Converters	29
4.2.1 <i>DC-to-DC Converter</i>	30
4.3 Maximum Power Point Tracking (MPPT) Controller	33

TABLE OF CONTENTS (Continued)

	Page
<i>4.3.1 Different Types of MPPT Techniques.....</i>	<i>34</i>
CHAPTER-5 CONCLUSION AND FUTURE SCOPE OF WORK	45
5.1 Conclusion.....	45
5.2 Future Scope of Research	45
BIBLIOGRAPHY.....	46

LIST OF TABLES

Table No.	Caption	Page
Table 3.1.	Specification table of solar cell [22]	18
Table 4.1.	Rules of fuzzy logic system	41

LIST OF FIGURES

Fig. No.	Caption	Page
Fig. 1.1.	Global energy consumption in the year 2012 [4].....	3
Fig. 2.1.	Spectral distributions of the black body radiation and the Sun radiation in the extraterrestrial space (AM0) and on Earth's surface (AM1.5) [25].....	10
Fig. 2.2.	Diagram of the AM1.5 path and the direct-normal and global incident radiations [25]	11
Fig. 2.3.	Process in an irradiated solar cell.....	12
Fig. 2.4.	Single diode model of PV cell and equivalent circuit of practical PV device .	13
Fig. 2.5.	Construction of Photovoltaic array [27].....	14
Fig. 2.6.	I-V and P-V characteristics of practical PV device [25].....	15
Fig. 3.1.	Block diagram of single solar cell.....	17
Fig. 3.2.	Schematic diagram of solar sub-module	18
Fig. 3.3.	Schematic diagram of the solar module	19
Fig. 3.4.	Schematic diagram of solar array.....	20
Fig. 3.5.	Modeling diagram of the PV generator connected with variable resistance....	21
Fig. 3.6.	Current versus Voltage (I-V) characteristic of PV generator.....	23
Fig. 3.7.	Power versus Voltage (P-V) characteristic of PV generator.....	23
Fig. 3.8.	I-V characteristic of the PV generator with different irradiance level.....	24
Fig. 3.9.	P-V characteristic of the PV generator with different irradiance level	25
Fig. 3.10.	Voltage versus time characteristic graph	26
Fig. 3.11.	Current versus Time characteristic graph	26
Fig. 3.12.	Power versus Time characteristic graph	27
Fig. 4.1.	Block diagram of the PV generator connected with the DC-to-DC converter and MPPT Controller	29
Fig. 4.2.	Simple PV generator with DC-to-DC converter	30
Fig. 4.3.	DC-to-DC buck converter	31
Fig. 4.4.	DC-to-DC boost converter.....	32

LIST OF FIGURES (Continued)

Fig. No.	Caption	Page
Fig. 4.5.	Algorithm of the Perturb and Observe method	35
Fig. 4.6.	Power versus Voltage curve of PV generator	36
Fig. 4.7.	Duty cycle versus Time graph	36
Fig. 4.8.	Output voltages of PV generator without P and O controller	37
Fig. 4.9.	Output voltages of PV generator with P and O controller [34]	37
Fig. 4.10.	Block diagram of fuzzy logic control (FLC) system	38
Fig. 4.11.	Schematic diagram of fuzzy logic system.....	39
Fig. 4.12.	Input Power (P) signal of fuzzy system	40
Fig. 4.13.	Change in input voltage ΔV signal of fuzzy system	40
Fig. 4.14.	Duty cycle output signal of fuzzy system	41
Fig. 4.15.	Surface view for the fuzzy logic inputs (P, ΔV) Vs output (D).....	43
Fig. 4.16.	Duty cycle versus Time graph of FLC system.....	43
Fig. 4.17.	Output voltages with PV generator with fuzzy logic controller	44

LIST OF SYMBOLS

x	Coefficient the path of the sun light
A	Ampere
C_{\min}	Minimum capacitance
dP	Change in power
E_g	Energy gap
FF	Fill factor
F_s	Switching frequency
I_d	Diode current
I_{mp}	Current at maximum power
I_o	Leakage current of the diode
I_{pv}	Photovoltaic current
I_{sc}	Short circuit current
k	Boltzmann constant
L_b	Critical inductance
N	Quality factor
q	Charge of the electrons
R	Load resistance
R_p	Equivalent parallel resistance
R_s	Equivalent series resistance

LIST OF SYMBOLS (Continued)

T	Temperature of the p-n junction
T	Total time period of signal
T_{on}	Active time of the signal
V_0	Output voltage
V_{mp}	Voltage at maximum power
V_{oc}	Open circuit voltage
V_{ref}	Reference voltage
V_s	Input supply voltage
V_t	Thermal voltage of array
α	Diode ideality factor
ΔV	Change in voltage
ΔV_0	Ripple output voltage
θ_z	Angle of the Sun

LIST OF ABBREVIATION

ASTM	American Society for Testing and Materials
CV	Constant Voltage
D	Duty Cycle
DER	Distributed Energy Resources
FLC	Fuzzy Logic Control
LRCM	Linear Reoriented Coordinates Method
MPP	Maximum Power Point
MPPT	Maximum Power Point Tracker
P&O	Perturb and Observe
PV	Photovoltaic
PWM	Pulse Width Modulation
STC	Standard Test Conditions

ABSTRACT

The most common way of harvesting the solar energy through photovoltaic panels or array is very popular and effective to receive photon energy from the sun. This energy intern, converted to electrical energy. In the present work the modeling and simulation of a PV generator considering practical on-site condition is performed. Its characteristics at different irradiation and temperature levels have been obtained by using the MATLAB/Simulink software. In the process of simulation, the constant and variable load condition are implemented. After simulation of the PV generator, its Maximum Power point is obtained with the help of two different techniques. The two different techniques are namely Perturbation and Observation method and fuzzy logic control (FLC) method which are mostly used to track the Maximum Power Point (MPP) of a PV generator by the variation of temperature and insolation. The main advantages of these two methods are to increase the efficiency of the PV generator and to extract the maximum power from the panel in least time. A DC-to-DC converter model is designed using MATLAB/Simulink in order to determine the performance of the MPPT controller. The output of both the MPPT controller remains connected with the Ideal switch of the converter to extract the maximum power output of the PV generator. The simulation results based on MATLAB-Simscape Systems are explained and shown.

1.1 Overview

The demand of the electricity is increased day by day due to the energy crisis and also widely increases because of increasing population and development in customary of living, particularly in developing country like India. Although in our world there are many remote areas with large population but has no access of electricity. In the year 2013 approximately 1.5 billion people around the world did not had the access of electricity. Due to the global warming and environment pollution there is a reduction in the fossil fuels, to overcome this problem the renewable energy resources are play an important role to increase the demand of electricity. Also fossil fuels are reducing very quickly, so there are critical essential for the world to change to renewable sources of energy which can be recycled again and again.

The renewable energy resources are those resources which are free from pollution and available free of cost. The renewable energy resources are the natural energy resources namely sunlight, wind energy, tidal energy, small hydro power, rain, geothermal, and biomass energy are included in distributed energy resources (DERs) .Due to the advantage of the non-polluting, the renewable energy resources are used as a distributed energy resources (DERs) which can be easily installed anywhere depending upon the availability of the non-conventional energy [1]. The main advantage of the renewable resources is easy to install, clean ecofriendly resource, less maintenance cost, and occupy less space for installation.

Among the above DER resources the solar energy is one of the most important energy resources to meet the demand of electricity. It is a limitless energy resource. The sun harvests huge quantities of renewable solar energy that can be collected and transformed into heat and electricity. Solar energy is the most abundant of all energy resources. Definitely, the rate at which solar energy is diverted by the Earth is about ten thousand times greater than the rate at which humankind consumes energy. Whereas not all countries are equally endowed with solar energy, a significant contribution to the energy mix from direct solar energy is possible for almost every country [2].

1.2 The Different Types of Renewable Energy Resources

- a) **Wind power:** This mainly depends on the airflow and the wind turbine mainly used to convert the wind energy into electric energy. The power output of this source is proportional to the cube of the wind speed and it increases gradually with the increase of wind velocity.

- b) **Solar power:** The pattern of solar energy is obligated its beginnings to the British astronomer John Herschel who famously used a solar thermal collector box to cook food during an expedition to Africa. Solar energy can be developed in two main methods. Firstly, the captured heat can be used as solar thermal energy, with applications in galaxy heating. Another alternative is the conversion of incident solar radiation to electrical energy, which is the most usable form of energy. This can be achieved with the help of solar photovoltaic cells or with absorbed solar power plants. The photovoltaic is an electronic device which converts the solar energy or radiation into the electrical energy.
- c) **Hydro power:** The rating of this kind of plant is up to 10 MW and it can be considered as the small hydro power plant. The main purpose of this plant is to convert the potential energy of stored water in dam into the electric energy with the help of water turbines.
- d) **Geothermal power:** Geothermal energy is the thermal energy which can be stored and generated within the layer of the earth. The gradient thus settled gives rise to a continuous conveyance of heat from the core to the surface of the earth. This gradient can be utilized to heat water to produce superheated steam and use it to run steam turbines to generate electricity [3].

1.3 The Renewable Energy Trends across the Globe

As can be seen in Fig. 1.1, the complete globe of energy consumption are shown for both convention and non-convention energy. The biomass and the wind inhabit the main share of present renewable energy consumption energy sources. New improvements in solar photovoltaic technology and constant cultivation of projects in the countries like Germany and Spain have carried around wonderful development in a solar PV market as well, which is predictable to the exceed other renewable energy sources in the coming years. In the 2010, more than 90 republics had some policy mark to complete a programmed part of their power capacity over renewables. Most of the targets are also very ruthless, arrival in the range of 30-90% share of general invention through renewables. Remarkable rules are the European Union's goal of the reaching 20% of total energy through renewables by the year 2020 and India's Jawaharlal Nehru Solar Mission, through which India plans to generate 20GW solar energy in the further 2022 year.

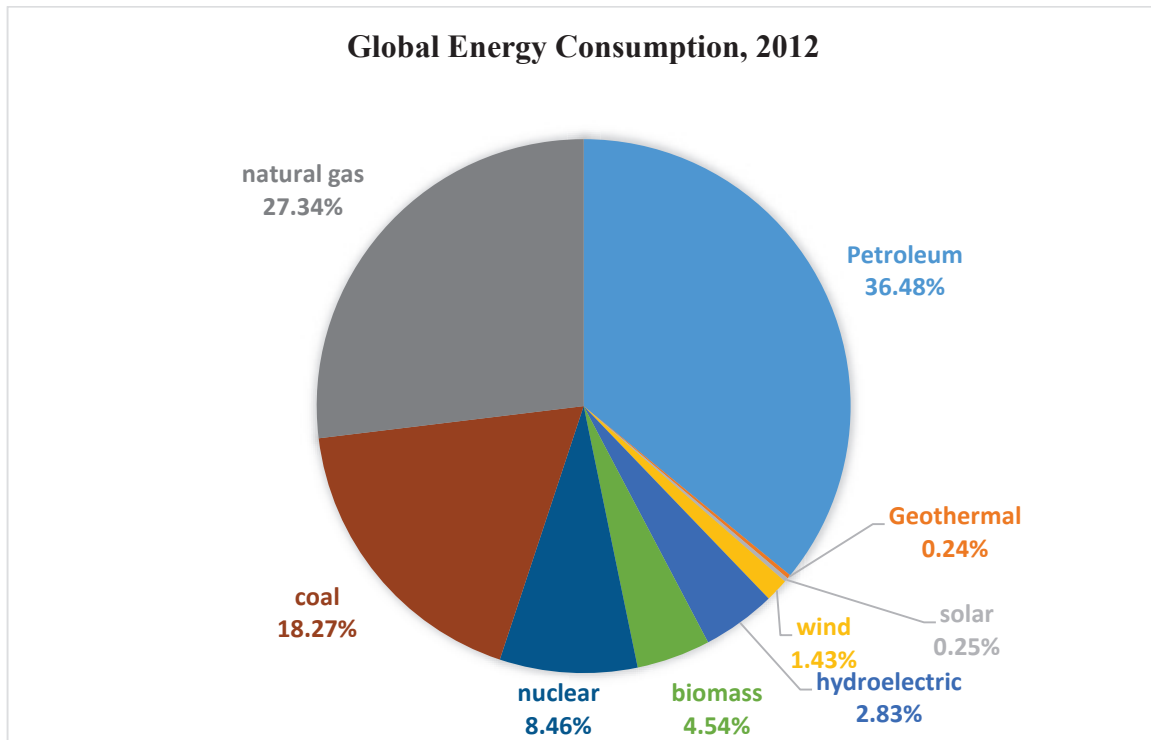

Fig. 1.1. Global energy consumption in the year 2012 [4]

The India is the first country in the world set up the non- conventional energy resource. The PV contributed approximately 4.5% along with biomass and small hydro power of renewable energy installed capacity in India. The total installed capacity of PV system in India is nearly 3062.8 MW.

1.4 Literature Review

There are many researcher which will work on the renewable energy resource. Some of following are given below:

Mao-Lin Chiang *et al.* (2002) [4], suggested a direct power control for distributed of PV system, a DSP is used to appliance the power feedback control, maximum power point tracking (MPPT) and unfalsified control for the PV generator. A MPPT control with duty ratio versus PV module output power has been developed. The Parameter tuning and adaptation of real-time PI controller is accomplished based on unfalsified control theory.

Yushaizad Yusof *et al.* (2004) [5], planned an approach to model of the PV generator and simulate the maximum power point tracker (MPPT) of photovoltaic (PV) system for the battery charging application. The incremental conductance method is used for the maximum power point (MPP) tracking purpose, which are developing using C programming. Model of a boost converter is created using

Matlab / Simulink, particularly with great utilization of the power system block set, (PSB), in order to verify the concert of planned MPPT system.

Carlos Meza *et al.* (2005) [6], describes the analysis, modeling and control of transformer less Boost-Buck power inverter used as a DC-AC power preparing stage for a grid-connected photovoltaic (PV) system. It also describes the unity power factor and the sensor less Maximum Power Point Tracking (MPPT) method to increase the efficiency of the PV generator.

Abu Tariq *et al.* (2005) [7], interfacing between a PV panel and its load to maximize the output power of the system. The MPPT force the operating point towards the Maximum Power Point (MPP) by changing the duty cycle of the DC-to-DC converter. A low cost analogy has been constructed and simulated.

Fang Luo *et al.* (2007) [8], proposed the variable step Maximum Power Point Tracking method using differential equation solution. The new MPPT gives the second order differential solution compared with the traditional MPPT methods which always behave as on order convergence. The simulation based mathematical model is proposed in this study.

D.Dondi *et al.* (2007) [9], Photovoltaic cell modeling for solar energy by using powered sensor networks suitable variable irradiation level strength, variable temperature and incident angle. This study is implemented in the indoor environment.

Noha El-Gohary *et al.* (2008) [10], proposed to obtain the Maximum Power Point tracking by using Microsatellite power system device based on the fuzzy logic based controller.

S.Chowdhury *et al.* (2008) [11], described the mathematical and performance evaluation of the stand-alone PV system with MPPT facility.

Jung-Sik Choi *et al.* (2008) [12], proposed a method to obtain the MPPT using Linear Reoriented Coordinates Method (LRCM) and this track method is mainly used in variable weather condition of commercial moderate programming technique.

Takuya Arayashiki *et al.* (2008) [13], compared the three different conventional method namely Perturbation and Observation method, incremental conductance method and CV algorithm and simulate them in the simulation software to find the MPPT power output of the PV generator. This is also proposed the MATLAB-based simulation method to predict and analyze the MPPT performance of the solar array.

Ye Zhihao *et al.* (2009) [14], gives an approach to design a high performance compensation loop for the PV generator system based on the constant voltage (CV) Maximum Power Point tracking which

are different from the common used DC-to-DC converter. It also used switch average model which are implemented in the buck converter of the PV system module. It also proposed the PI controller for designed the compensated loop. The performance of the PV system with and without return is also proposed and simulated by using Cadence Specter.

Liu Hongpeng *et al.* (2009) [15], designed a double index model of the PV cells in the simulation based using MATLAB environment. It also proposed Maximum Power Point Tracking (MPPT) circuit model based on the double index model. The double index model is combination of the series and parallel connected PV cells. This double index model is also compare with the single circuit; the double index model is more accurate as compared to the single index model. This also present the P and O method of PV system is analyzed and connected with DC-to –DC converter and check its output performance.

R. Ramaprabha *et al.* (2009) [16], designed a solar array modeling and simulation of the Maximum Power Point Tracking (MPPT) by using an artificial technique known as Fuzzy logic technique. In this it design a solar panel in the MATLAB environment at which changing the intensity of the light the output of the system and its internal resistance increases. For tracking the Maximum Power Point (MPP) from the panel, the internal resistance is equal to the load resistance. The MPPT are used to operate a photovoltaic panel at its MPP in order to increase the system efficiency. It is also presented the improved model of the solar system and a back propagation neural network based MPPT for boost converter in a standalone system under variable irradiation and the temperature.

Marcelo Gradella Villalva *et al.* (2009) [17], suggests the analysis and simulation of the Perturbation and Observation Maximum Power Point Tracking algorithm a linearized Photovoltaic array model and improved the output of the system when the electronic device namely converter are correctly controlled. The linearized Photovoltaic (PV) array model is used to obtain the transfer function of the converter and designed a voltage compensator for the converter input. In this proposed work the buck converter.

Ting –Chung Yu *et al.* (2009) [18], analyzed and simulate the characteristics of the Photovoltaic system and track the maximum power from the PV system with the help of P and O algorithm by using MATLAB/ Simulink software . It also designed a DC-to-DC buck-boost converter to extract a maximum power form PV system and improved its efficiency. It proposed an accuracy and practicability of the Photovoltaic simulation system.

R.Sridhar *et al.*(2010) [19], also proposed a modeling and simulation of the Photovoltaic model with temperature variation and sun's irradiance level and also voltage and current characteristics are drawn according to the system input. The P and O algorithm technique is used to track the Maximum Power Point (MPP) which is mainly used for track the peak power to maximize the output power of the system. The P and O algorithm identify a suitable duty cycle ratio which will give to a DC-to-DC converter to obtain the maximum power output.

F.A.O. Aashoor *et al.* (2013) [20], presented a fuzzy logic control (FLC) scheme to extract a maximum power from the Photovoltaic stand-alone system. In this scenario PV generator comprises a solar panel system, a DC-to-DC buck or boost chopper and fuzzy logic MPP tracker. The main purpose of the fuzzy logic control (FLC) system to generate the control signal which is given to the PWM generator to automatically adjust the duty ratio of the DC-to –DC buck converter in which the load impedance match with the PV generator impedance to track the maximum power from the generated system and to increase the efficiency of the PV generator.

Prasenjit Basak *et al.* (2013) [21], presented the Simscape based modeling of the PV generator in micro grid scenario and also perform the fixed load or variable load characteristics with varying the irradiance level and varying the temperature of the solar system. It mainly focused on the inverter based micro grid system on distributed energy resource catering the ac load as sample study of industrial application

Dhaker ABBES *et al.* (2013) [22], worked on an Advanced synthetic study of the Modeling and the simulation of the PV generator. It also presents the same Perturbation and Observation algorithm technique and Incremental conductance method to track the Maximum Power Output (MPP) output of the converter which will be adjusted by the duty cycle and make the system more efficient. A although method is used for determine a PI current controller.

Enrico Dallago *et al.* (2015) [23], proposed the direct algorithm for the PV source with only voltage measurement. In this the direct algorithm accurate detect the Maximum Power Point (MPP) and quickly track in the presence of the irradiance of the solar system. It use the double fed capacitor inverter (DCI), is design to charge the DC link of the inverter and follow the MPP of the PV generator. The method is improve the efficiency of the PV generator.

1.5 Motivation

In order to realize whole rural electrification and reliable power, commercial expansion of non-conventional resources, such as solar cells or the PV generator is essential. The solar energy is a clean

source of energy and mainly depends upon the sun light or radiation as a fuel. Solar power is free and it is practicable to generate power out of the sun radiation falling on the earth. Thus the Solar PV generator System has developed the order of the daylight. The average of the solar irradiation at full sun is assumed to be a 1000 w/m^2 whole of the globe. The irradiation of the solar system changes from day time to till at the evening time so, the output is not constant during the day. A battery is connected with the solar panel with the help of relay and the unidirectional diode. The purpose of the relay is to charge the battery at day time and disconnect the solar system during the night time and the load is supplying from the battery system. The purpose of the diode is to give the unidirectional output to the load. When the output is not constant throughout the day then it is important to extract the maximum power from the solar module at any point of time. To achieve this process, various maximum power point tracker methods are used. In this research work the PV generators is connected to the variable and fixed load resistance and then obtain its characteristics with variation of the temperature and the irradiation level of the solar radiation. In this research work a Simscape based modeling of a PV generator and the MPPT is obtain by using the MATLAB/Simulink software.

1.6 Objective of Work

The objective of this dissertation is to study the Simscape based modeling of the Photovoltaic (PV) generator when connected with the variable load resistance by using MATLAB/Simulink. The effects of irradiation and the temperature variation upon performance of PV generator are investigated. The work explores the response of the PV generator by changing the temperature and solar irradiation level. The objectives of the dissertation are stated below:

- (a) To perform a comprehensive literature survey on the aspect of PV generator technology to be implemented in the system.
- (b) To study the performance of the Photovoltaic generator supplying a fixed or variable resistance through modeling and simulation by using Simscape in MATLAB/Simulink.
- (c) To study the Current versus Voltage (I-V) characteristics and Power versus Voltage (P-V) characteristic of the PV generator with variable resistive load.
- (d) To study the performance of Maximum Power Point tracking (MPPT) of the PV generator by using the Perturbation and Observation (P and O) controller method and artificial intelligence based fuzzy logic control (FLC) method are used.

1.7 Organization of the Dissertation

The work is organized into five chapters and contents of each chapter are summarized below:

- (a) Chapter 1 presents the overview of proposed work, literature review, motivation and objective of the work.
- (b) Chapter 2 presents theory behind the Photovoltaic cells.
- (c) Chapter 3 includes modeling and simulation of the PV generator and its characteristics.
- (d) Chapter 4 includes the simulation of maximum power point trackers (MPPT) of PV generator and its result.
- (e) The conclusion and future scope of research are concluded in chapter 5.

THEORY BEHIND PHOTOVOLTAIC CELL

The solar energy is one of the most important sources of renewable energy. The earth collects large energy from the sun to meet its needs for a year. A Photovoltaic (PV) cell is a semiconductor device that directly converts the solar radiation into the electrical energy. In general, an element that converts sunlight into the electricity is called a PV device. The major PV device is the PV cell, while a number of cells are connected to form a panel or module. As an array either a module or a set of modules can be considered.

The main purpose of this chapter is to provide an introduction of the Photovoltaic solar energy and to present behavior and functioning of the Photovoltaic (PV) device with the intension of providing in-depth analysis of the PV phenomena and the semiconductor device.

2.1 Solar Energy Conversion

Photovoltaic (PV) energy conversion is mainly defined as the direct conversion of solar radiation into electric energy; depend upon the phenomena of photovoltaic effect. Typically, the term photovoltaic effect denotes to the generation of a potential difference at the junction of two different materials in response to visible or other radiation. Thus, the broad study area of solar energy conversion into electric energy is denoted as photovoltaic.

2.1.1 Solar Radiation

As explained in the above section, the simple procedure of solar cell operation is the generation of the electron and hole pairs which is the result of the absorption of visible or other electromagnetic radiation with the help of semiconductor material. The Sun is a source of light having a radiation spectrum that can be related to the spectrum of a black body at temperature of nearly 6000K. A black body absorbs and radiates electromagnetic radiation in all the wavelengths and theoretical distribution of wavelengths can be explained with the help of Planck's law. In Fig. 2.1 the spectral distribution of the black body radiation compared to the extraterrestrial and terrestrial solar radiations is shown. The spectrum of the sunlight which strikes on the of the Earth depends on the different factors, like the variation of temperature on the solar disc and effect of the atmosphere, making the study of the effect of the solar radiation on PV devices quite complicated. The average distance between the sun and earth, the irradiance, the flux of the solar irradiation incident on the surface outside the atmosphere is about 1.373kW/m^2 which can be calculated with the formula of $S_0 = E / (4\pi R^2)$, where S_0 is the solar constant

as describes the average power per unit area of the solar irradiation strikes on the surface of the sphere of radius R around sun. R is the average distance of earth and the sun around 150,000,000,000 m or while radiations on the earth surface is 1 kW/m² [25].

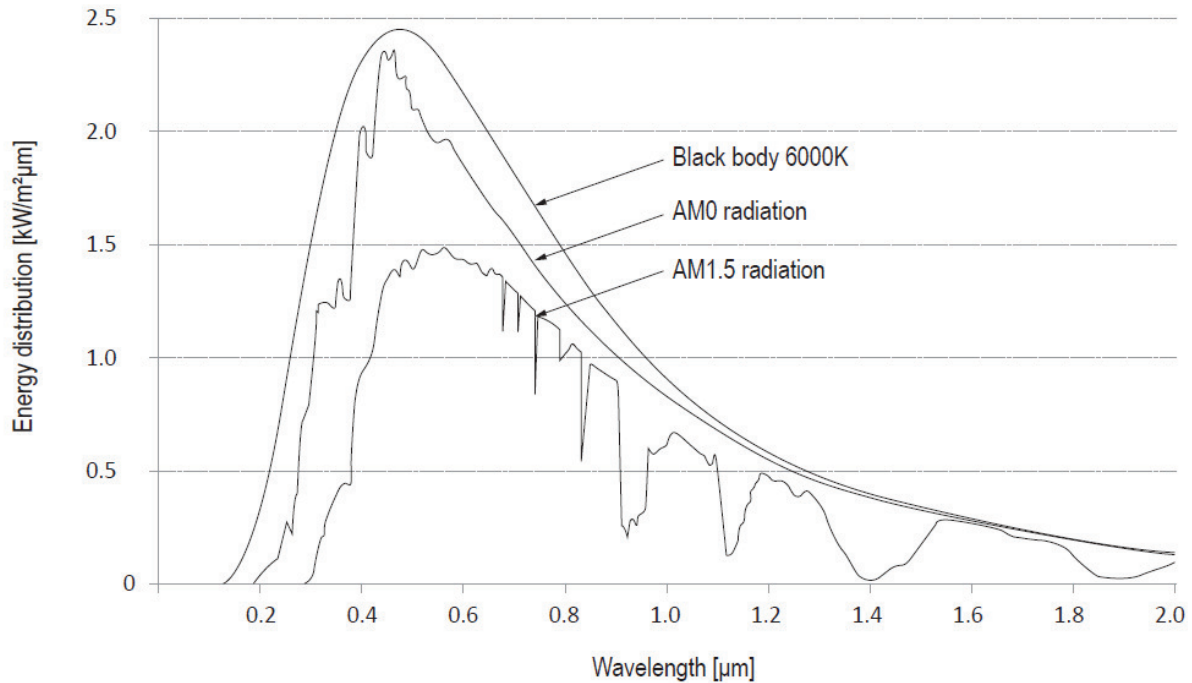

Fig. 2.1. Spectral distributions of the black body radiation and the Sun radiation in the extraterrestrial space (AM0) and on Earth’s surface (AM1.5) [25]

There are two standard terrestrial spectral distributions. One is direct normal and the other a global AM1.5, there both are described by the American Society for Testing and Materials (ASTM). The AM signifies the air mass, further precisely the mass of air between the earth surface and the Sun that effects the spectral distribution and intensity of the sunlight. The term AM1.5 value is described for the Photovoltaic (PV) device with the earth surface at 37° sloped, while facing the Sun [24]. The length of the path of the solar radiation through atmosphere is indicated with the help of AM_x number. Longer the path of radiation leads to more light deviation and absorption. The above phenomena represents an influence on the spectral distribution of the light received by the PV device. The x coefficient the path of the sun light is presented as:

$$x = \frac{1}{\cos\theta_z} \tag{2.1}$$

Where, θ_z is the angle of the Sun with reference to the zenith [3] shown in Fig. 2.2.

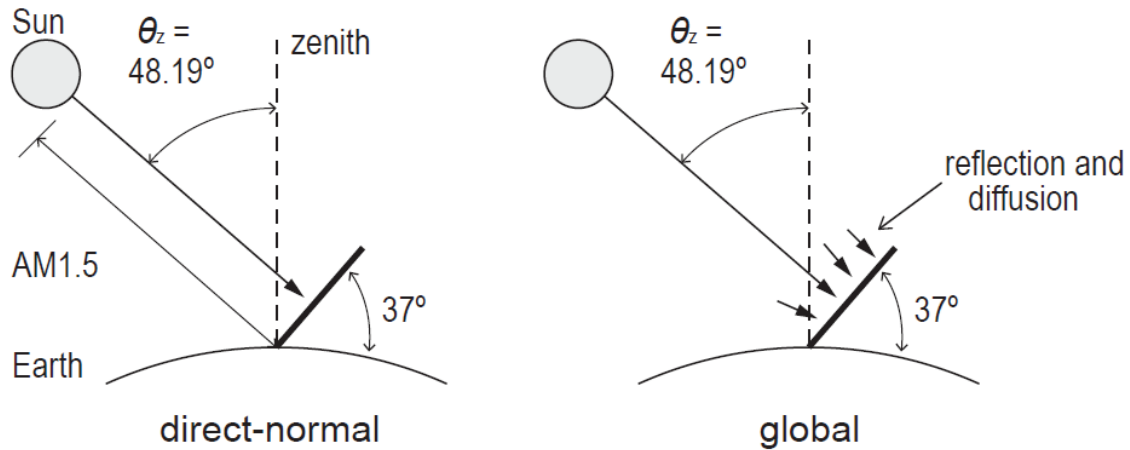

Fig. 2.2. Diagram of the AM1.5 path and the direct-normal and global incident radiations [25]

The larger the value of the x longer the path and greater the air mass between the Sun and the earth surface of the photovoltaic (PV) device. The term AM1.5 distribution relates with the Sun radiation with a solar angle $\theta_z = 48.190^\circ$. The direct-normal path and the global path are shown in above diagram. Depending on the environmental situation like, time, day of the year, weather conditions, composition of the atmosphere, elevation, etc. the total intensity and the spectral distribution of the solar radiation can change. In conclude with all these above conditions the performance and the characteristics of the Photovoltaic devices with respect to the Standard Test Conditions (STC) indicates the irradiance of 1000 kW/m^2 with the temperature of AM1.5 spectrum at 25°C .

2.1.2 Photovoltaic Cell Operation I

A Photovoltaic cell is a semiconductor p-n junction photodiode, which can produce the electric power when exposed to light. There are different types of semiconductor materials which are used for the Photovoltaic cell or PV cells constructions. The most common types of cells which are used known commercially are mono-crystalline, poly-crystalline and amorphous silicon (Si). The principal operation of the PV cells depends on the phenomena of the photovoltaic effect which are shown in Fig. 2.3. This effect can be defined as a phenomena in which due to the absorption of the sun light with the certain wavelength the electrons get ejected from the conduction band by the material either solid, liquid, gas, metallic and non-metallic [25]. Thus, the absorption of the solar energy by semiconductor material is proportional to the radiation strikes on the surface of the PV cells.

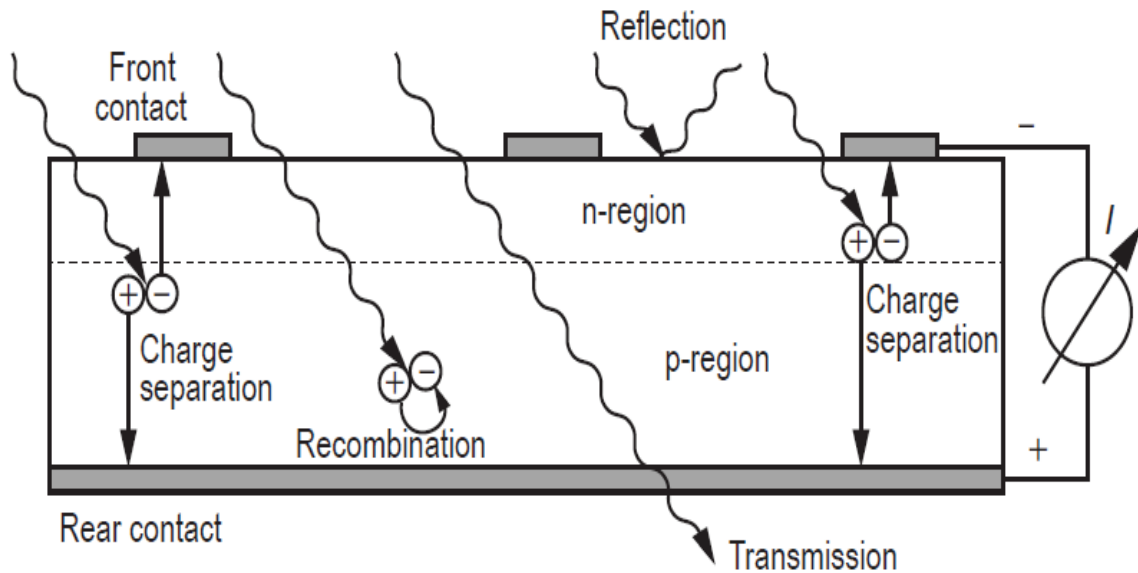

Fig. 2.3. Process in an irradiated solar cell

When the absorbed energy is greater than the bandgap energy of the semiconductor, the electron placed in the valence band moves or jumps to the conduction band. So pairs of the electron- holes are generated in the region of the semiconductor. Therefore electron generated in the conduction band are able free to move in this region. The free electrons have to move in the direction of the electric field present in the PV cells. The moving of free electrons generates a current, which can be drawn for the external use by connecting a metal plate between the top and the bottom edge of the PV cell. Therefore the voltage and the current created because of its built electric field and also generate power .The voltage, current and power is measured by connection the measurement instrument connected with the PV cell [25]. The flux of incident light along with the capacity of absorption of the semiconductor affects mainly the rate of generation of electric carriers. The performance of the cell is dependent on various factors, such as the semiconductor bandgap, reflectance of cell surface, intrinsic concentration of carriers of the semiconductor, the mobility of electrons , the recombination rate and the temperature 25 °C.

2.2 Mathematical Equation of the PV Cell

2.2.1 Ideal PV Cell

To solve the analysis of the Photovoltaic cell in the electrical circuit, the electric model of the PV cell is described. The equivalent circuit of the Photovoltaic cell is shown in Fig. 2.4 [24]. In the single- diode model of the PV cell and the Equivalent circuit for practical PV device consist current source which are driven by the Sun radiation and an ideal diode

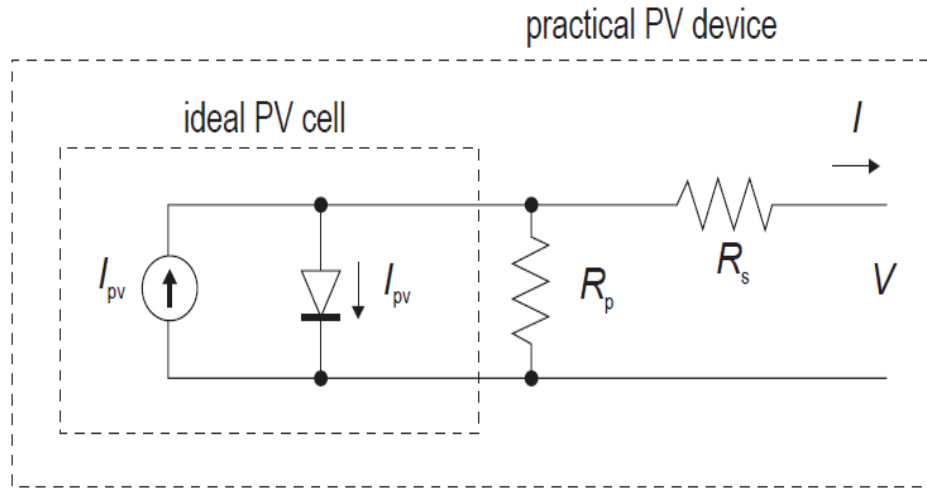

Fig. 2.4. Single diode model of PV cell and equivalent circuit of practical PV device

The mathematical equation of the PV cell is given below.

$$I = I_{PV} - I_0 \left[\exp \left(\frac{qV}{\alpha kT} \right) - 1 \right] \quad (2.2)$$

Where,

I_{PV} = current generated by the incident light and it is directly proportional to the solar irradiance

I_0 = Leakage current of the diode

q = Charge of the electrons ($1.602 \times 10^{-19} \text{C}$)

k = Boltzmann constant ($1.3806 \times 10^{-23} \text{ J/K}$)

T = Temperature of the p-n junction (K)

α = Diode ideality factor

The equation 2.2 represents the Shockley diode current represented with I_d . The net current I of the cell is calculated as the sum of the light generated current I_{PV} by radiations and the diode current I_d .

2.2.2 Construction of PV Modules and Array

The generated output voltage of the single PV cell is relatively very small and relatively a high current, so the large numbers of PV cells are connected in series or parallel enclosed in the common frame to form the module or Photovoltaic panel. The conduction loss in the cable is minimized when the PV cells are connected in series and the output voltage of the Photovoltaic panel is increased. A PV signifies the basic building blocks for huge scale PV power production.

A string of the module can be formed when multiple PV module stacks connected in series. As a result the voltage increases. The PV array is formed by connecting the multiple strings in parallel. For an array to produce well output voltage, all the modules must not be shaded. Then it will act as a load resulting in heat, which may destruct the solar cell. The bypass diode is used to avoid damage of the solar cell, however resulting in an increase in cost. The power level of the PV string can be ranged from a few hundred watts up to 5kW. For the PV array the power rating can be ranged from a few hundred watts up to hundreds megawatts in case of large scale PV plant [26]. The construction of the PV array is shown in Fig. 2.5.

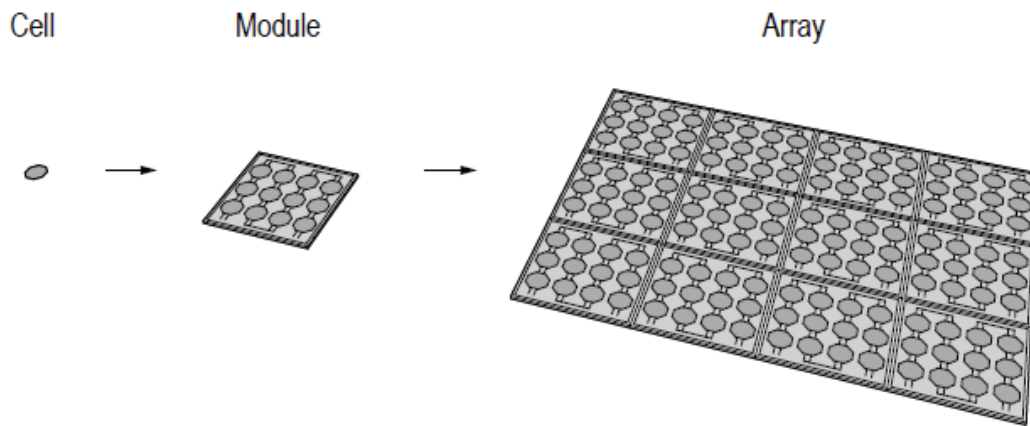

Fig. 2.5. Construction of Photovoltaic array [27]

Conversely, the simple equation of the ideal PV cell does not relate to the I-V characteristic of a practical PV array. The observation of the characteristics at the terminal of the PV array requires also additional parameters shown in the equation (2.3) below:

$$I = I_{PV} - I_0 \left[\exp\left(\frac{V + R_s I}{V_t \alpha} \right) - 1 \right] - \frac{V + R_s I}{R_p} \quad (2.3)$$

Where, I_{PV} = Photovoltaic current [A]

I_0 = Saturation current [A]

V_t = Thermal voltage of array [V]

R_s = Equivalent series resistance of array (Ω)

R_p = Equivalent parallel resistance of array (Ω)

α = Diode ideality constant

The above equation (2.3) describes the single-diode model equation of a PV cell. However for the more precise models have been projected, such as double exponential model with two diode are mainly used. The single - diode model is widely used because it offers the good compromise between simplicity and accuracy.

From the above equation (2.3), the Current versus Voltage (I-V) characteristics and Power versus Voltage (P-V) characteristics of the Photovoltaic (PV) device is explained which is shown in Fig. 2.6

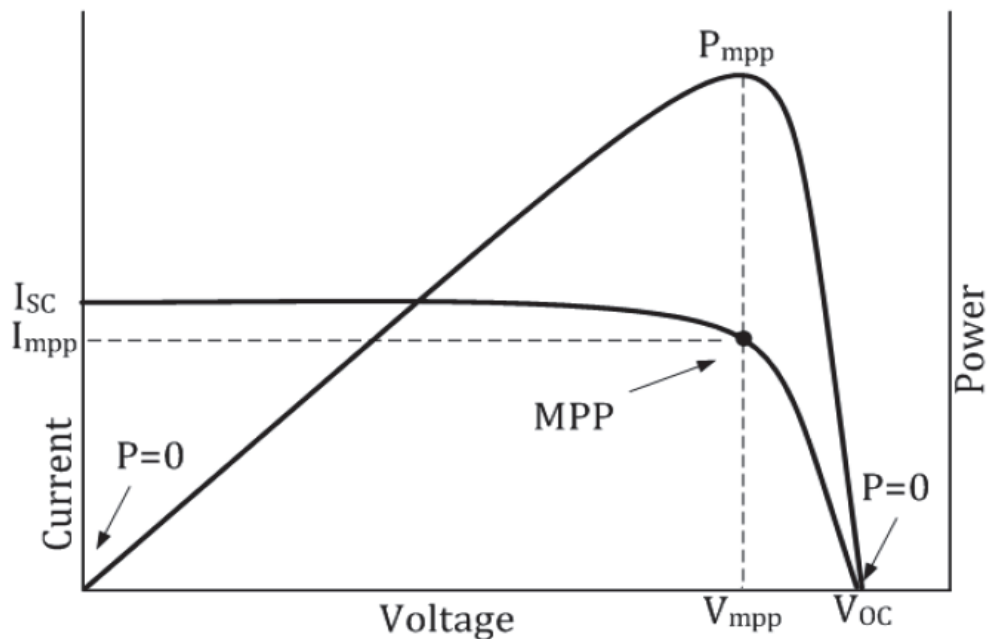

Fig. 2.6. I-V and P-V characteristics of practical PV device [25]

There some points are highlighted of the above figure; the short circuit point $(0, I_{sc})$ at this point the power is zero, the open circuit point $(V_{oc}, 0)$, at this point the power is zero, and the Maximum Power Point (MPP) (V_{mp}, I_{mp}) where the power is maximum[2]. At the specific level of the solar irradiance the PV panel delivers a maximum output power known as a (MPP).

2.3.3 Fill Factor of PV Module

The term fill factor is important. The manufacturers provide some data about the thermal and electrical characteristics of the PV device. The fill factor may be defined as the ratio to the maximum power (P_{mp}) to the open circuit voltage (V_{oc}) and the short circuit current (I_{sc}) of the PV module. The fill factor may be represented by the following equation 2.4.

$$\text{Fill factor (FF)} = \frac{P_{\text{mp}}}{V_{\text{oc}} \cdot I_{\text{sc}}} = \frac{V_{\text{mp}} \cdot I_{\text{mp}}}{V_{\text{oc}} \cdot I_{\text{sc}}} \quad (2.4)$$

In the fill factor the basic information is provided about the PV device, the important information is given in the datasheets are: the nominal short circuit current (I_{sc}), the nominal open circuit current V_{oc} , the current at the MPP (I_{mp}), the voltage at the MPP (V_{mp}), the peak output power at the MPP (P_{mp}) and temperature or irradiance condition of the PV module [27] .

MODELING AND SIMULATION OF THE PV GENERATOR

This chapter presents the modeling of the Photovoltaic (PV) generator connected to the DC load by using the Simscape MATLAB/Simulink environment. The Simscape is also a part of the MATLAB/Simulink but the difference between the Simulink and Simscape is that, in the Simulink blocks denotes the basic mathematical operation. When we connect Simulink blocks together, the resultant diagram is corresponding to the mathematical model, or illustration, of the system under design. In Simscape technology, the network illustration of the system under design is created based on the Physical Network approach. According to this method, each system is signified as consisting of functional elements that interact with each other by swapping energy through their ports. To study the performance of the solar energy based system earlier on-site installation the step by step modeling of the Photovoltaic (PV) is described in detail. Also discussed the DC-to-DC converters connected with the DC load is discussed. The current versus voltage (I-V) and power versus voltage (P-V) characteristics are represented and the simulation scope results are discussed.

3.1 Description of PV Generator Model in Simscape MATLAB/Simulink Environmental

In the modeling of a PV generator first of all create the sub-module, module and array of the solar cell are arranged. This solar cell block is drawn from the Simscape library. In the Simscape library there are set of blocks and features to develop system. In the solar cell there are three terminals one is the positive terminal, second is the negative terminal and third is the insolation or irradiance terminal. The block diagram of a single solar cell is given in Fig. 3.1.

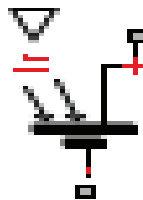

Fig. 3.1. Block diagram of single solar cell

3.1.1 Specification of the Solar Cell

The table 3.1 shows the complete specification of the solar cell.

Table 3.1. Specification table of solar cell [22]

Open circuit voltage V_{oc} of solar cell	0.6V
Short circuit current I_{sc} of solar cell	7 Amps
Quality factor, N	1.5
Maximum Irradiance used for measurement	1000 w/m ²
Series resistance, R_s	0 ohm
Measurement temperature	25 ⁰ C
Energy gap, E_g	1.11eV
Temperature exponent for series resistance	0
Temperature exponent for saturation current	3
First order temperature coefficient for solar induced current	0K ⁻¹

3.1.2 Solar Sub-Module

The output voltage of the single cell is very small about 0.6 volts which does not meet the load demand. To increase the output of the system the solar cells are connected in series or parallel combination and all of them are subjected to the same irradiation level. This is shown in Fig.3.2.

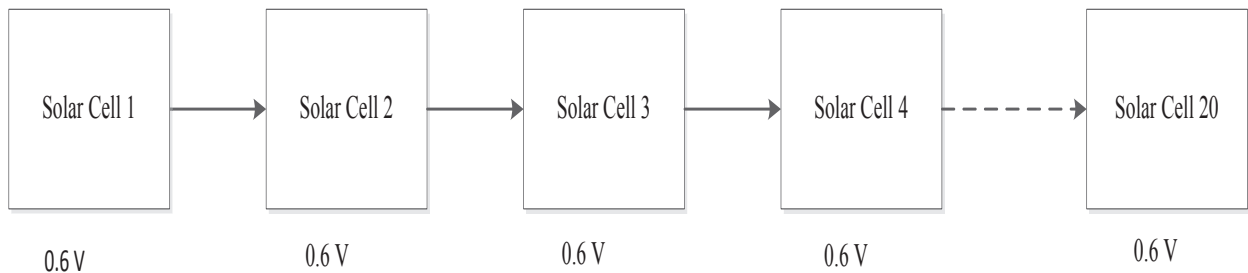

Fig. 3.2. Schematic diagram of solar sub-module

In the sub-module there are total 20 number of solar cell which are connected in a series, each having the open circuit voltage V_{OC} of 0.6 volt. The irradiation level of the solar sub-module is same around 1000 w/m^2 . This irradiation level increases or decreases according to the radiation of the sun. The open circuit voltage V_{oc} of the solar sub-module = (Open circuit voltage of each solar cell) * (total number of cell connected in series) = $(0.6*20)$ Volts = 12 Volts and the short circuit current I_{sc} of solar sub-module is 7 A [21].

3.1.3 Solar Module

In this section the two sub- modules are connected in parallel to create a single solar module. The schematic diagram of the solar module is shown in Fig. 3.3.

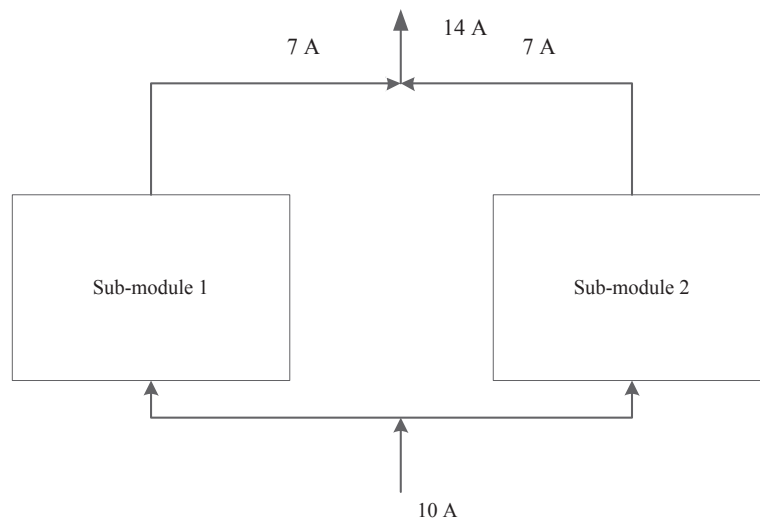

Fig. 3.3. Schematic diagram of the solar module

The open circuit voltage V_{oc} of the solar module is same as 12 volts because these are connected in parallel form and the short circuit current I_{sc} of the solar module = (short circuit current of each sub-module) * (Number of solar sub-module connected in parallel) = $(7 * 2) = 14 \text{ A}$.

3.1.4 Solar Array (PV Array)

Subsequently the Output voltage from one PV cell is very irrelevant to meet the loads; a PV array is made by connecting many such PV cells in series and parallel so as to attain the desired voltage and current. In the PV array there are total 20 numbers of solar modules which are connected in series each having a voltage 12 volts and the current is 7 A. The schematic diagram of the PV array is shown in Fig. 3.4 [2]. The open circuit voltage V_{oc} of PV array = (Open circuit voltage V_{oc} of each solar module) *

(Total numbers of solar modules are connected in series) = $(12 * 20) = 240$ Volt and the short circuit current I_{sc} of the PV array is 7 A. Now create the sub subsystem of the PV array to make the model of the PV generator.

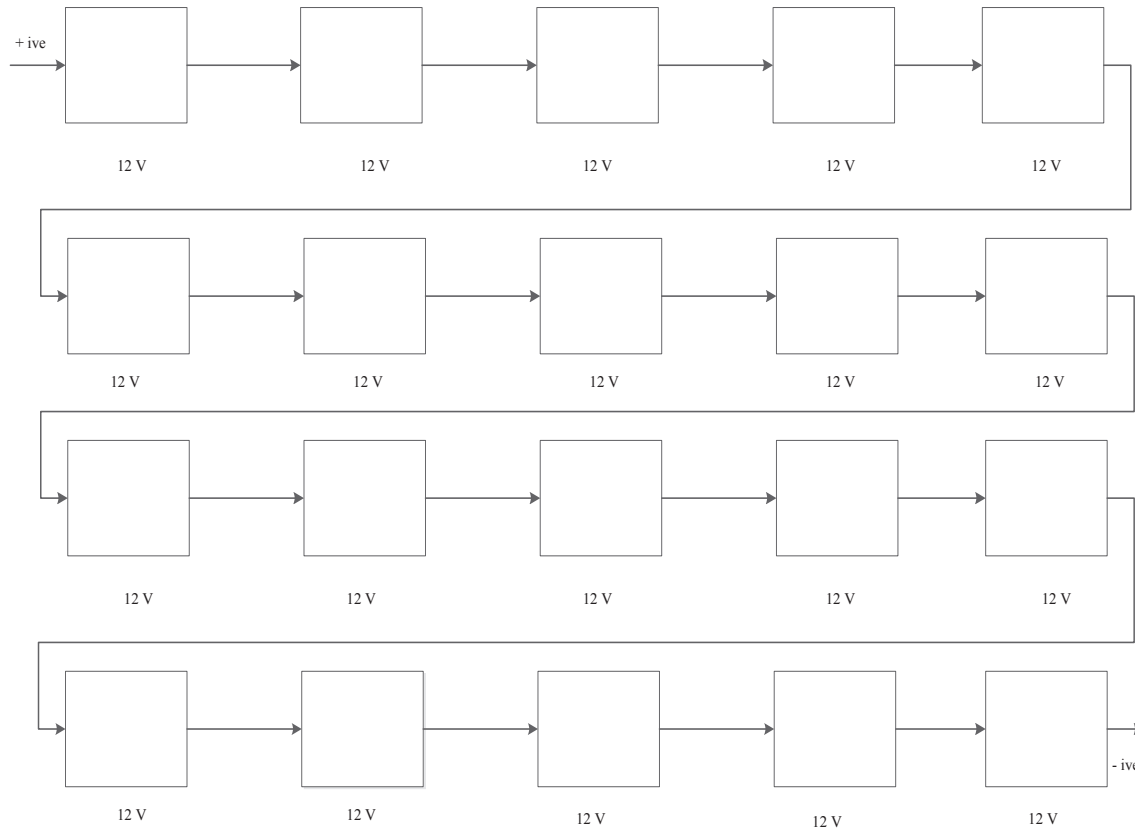

Fig. 3.4. Schematic diagram of solar array

3.2 Simscape Based Modeling and Simulation of PV Generator to Obtain I-V and P-V Characteristics

The Simscape based modeling of the Photovoltaic (PV) generator by using MATLAB/ Simulink software are shown in Fig. 3.5. The different components which are connected in the diagram are described below:

- a) Solver configuration block - The physical network which is represented in Simscape blocks requires the solver setting for the simulation purpose. This block is mainly used to solve all the mathematical equation in system. Each topologically different Simscape block diagram needs correctly one Solver Configuration block to be connected in the circuit .This block is improve the simulation time of the system.

- b) PS constant block - In the diagram this block gives the physical signal to the PV generator. This gives the irradiation signal to the PV generator which is radiations comes from the Sun. This block gives both the positive and negative physical signal.
- c) Converters – In the diagram two converters are used which converts the physical signal to the Simulink output signal known as PS-Simulink converter and the converter which converts the unitless Simulink input to Physical output signal known as S-PS converter. Both the converters have only one output port which is connected to the scope or the other system.
- d) Ramp block – It generates a signal that starts at specific time and value and change with in the specific rate. It also generates the continuously increasing and decreasing signal.

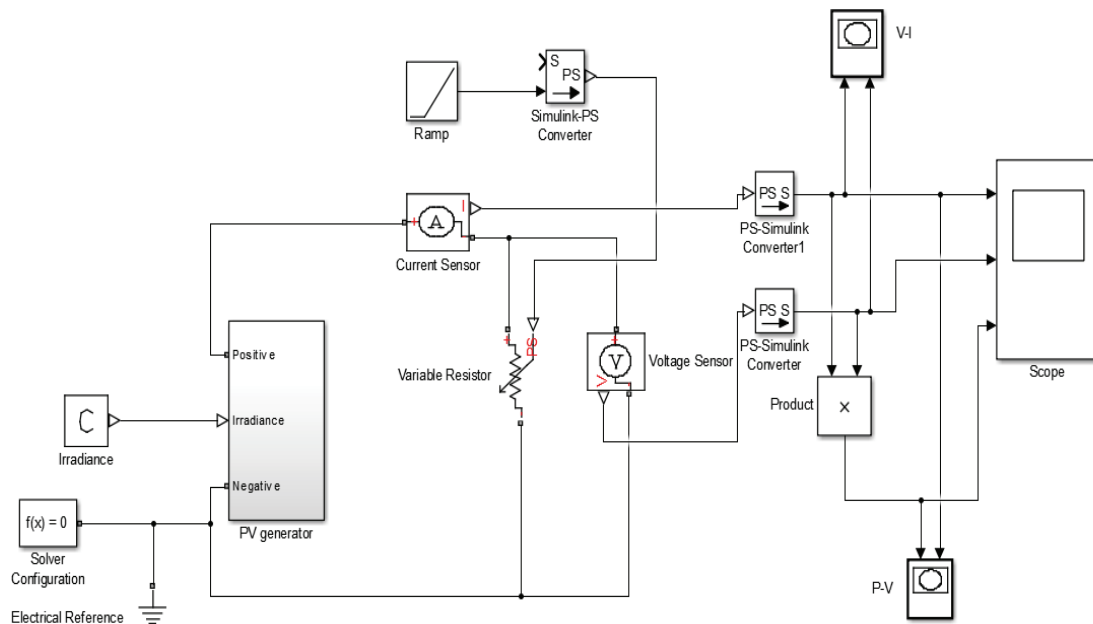

Fig. 3.5. Modeling diagram of the PV generator connected with variable resistance

- e) Variable resistor – A linear variable resistance may be used. This resistance is depend on formula $V = IR$ known as ohm's law. The current is positive across resistance if it flows from positive to negative and the voltage of the across the resistance is the difference between the positive and the negative terminal voltage. The minimum value of the variable resistance is $R \geq 0$.
- f) Voltage sensor – It is a device which converts the measured voltage between the electrical connections into the physical signal extent to the voltage. It is also denoted as an ideal voltage sensor.

- g) Current sensor – It is a device which converts the measured current between the electrical branch in to the physical signal proportion to the current. It is denoted as an ideal current sensor.
- h) PV generator – This is the main supply source which is created by the combination of the solar cell. The open circuit voltage V_{oc} of the PV generator is 240V and the short circuit current I_{sc} is 7A, so the total power deliver by the PV generator is $240*7=1680W$ [28].

3.2.1 Characteristics of the PV Generator

The voltage, current and power which are delivered by the PV generator is mainly influenced by:

- a) Condition of the sun radiations or light, wavelength, angel of incidence, intensity. The visible band gives the maximum power.
- b) Condition of termination, temperature, junction, irradiation level.
- c) External resistance connected in the load.

The rating of the PV generator are specified for a particular reference condition with the help of characteristics.

3.2.1.1 Current versus Voltage (I-V) Characteristic of PV Generator

The I and V is the direct voltage and direct current measured in the PV generator circuit during the full sun radiations or light. The typical Current versus Voltage (I-V) characteristics of the PV generator is shown in Fig. 3.6. In the I-V characteristic of the PV generator the voltage and the current changed according to the change the variable resistance which is connected as a load. When the resistance is very high the condition is called open circuit. At the initial point of the curve the voltage is zero and the current is maximum around 7A. It is the condition of the short circuit [27]. The range of the variable resistance is $R \geq 0$ to maximum. . Due to changes the resistance from zero to maximum then the current versus voltage graph will change and this change is shown in graph with the blue line.

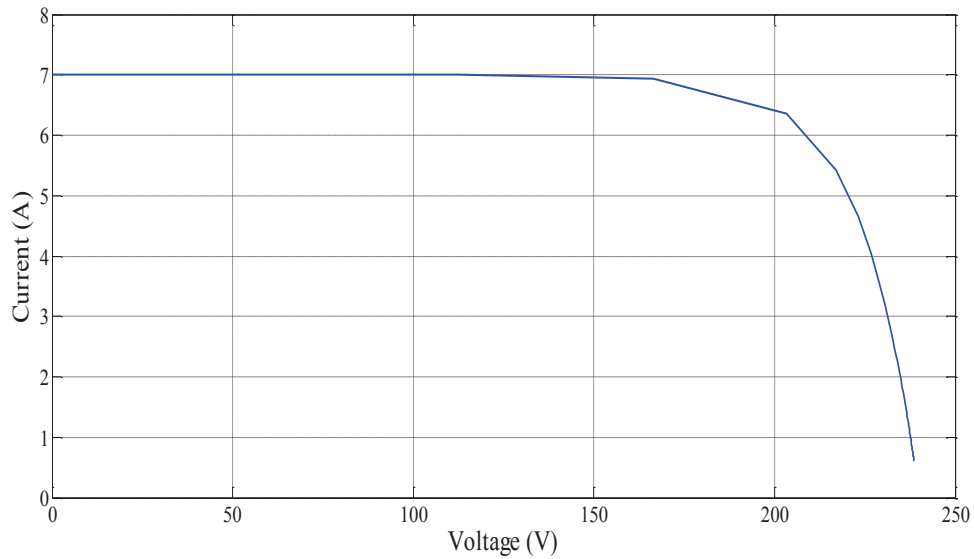

Fig. 3.6. Current versus Voltage (I-V) characteristic of PV generator

3.2.1.2 Power versus Voltage (P-V) Characteristic of PV Generator

The power is the product of voltage and the current according to the ohms law $P = V \cdot I$. At initial point when the voltage is zero then the power is also zero. The voltage is directly proportional to the power according to the formula. The typically Power versus Voltage (P-V) graph as shown in Fig. 3.7.

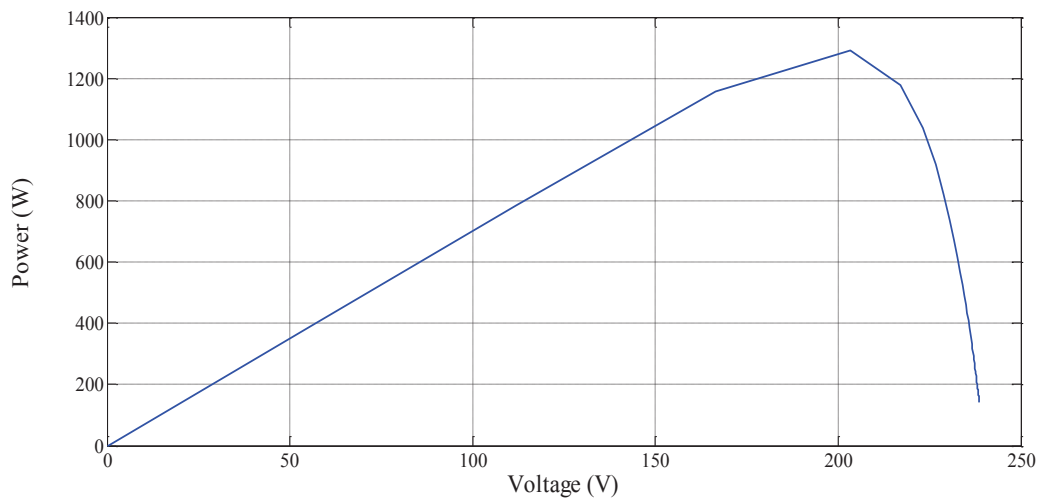

Fig. 3.7. Power versus Voltage (P-V) characteristic of PV generator

The voltage of the PV generator is mainly dependent on the solar irradiation or the temperature. At the full sun light, the solar irradiation is approximately 1000 w/m^2 and the temperature is 25° C . Due to this

condition, a particular operating point is obtained which is known as Maximum Power Point (MPP). In the above graph the blue line shows the power change with respect to voltage.

3.2.1.3 Factor Affecting the Photovoltaic (PV) Generator Characteristic Curve

The electrical characteristics of the PV generator denoted by current versus voltage and power versus voltage curve are represented in Fig. 3.6 and Fig. 3.7 respectively. These totally dependent on the weather condition such as temperature and irradiance. The effect of the different level of irradiance on the characteristic curve of the PV generator is shown in Fig. 3.8 and Fig. 3.9. The irradiation level range for a typical PV generator is varies from 1000 w/m^2 to 200 w/m^2 .

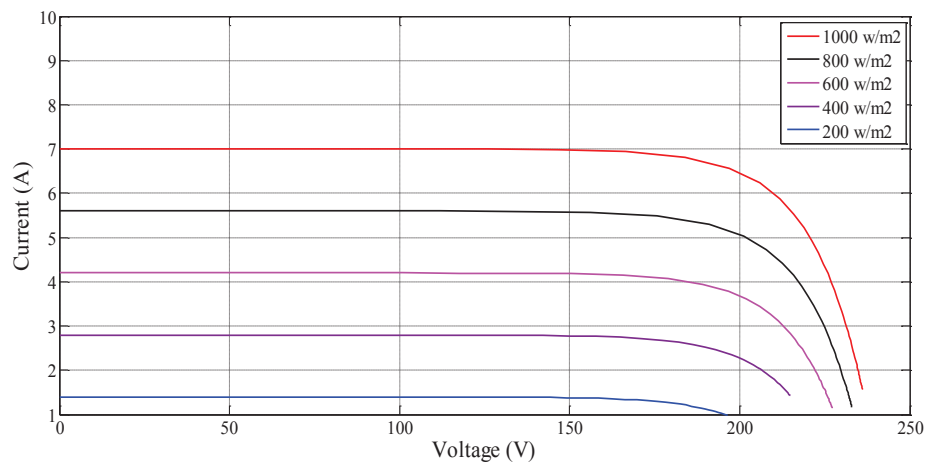

Fig. 3.8. I-V characteristic of the PV generator with different irradiance level

In the above Figure the red line shows the short circuit current as 7A when the irradiation is maximum around 1000 w/m^2 . The black line indicates the short circuit current as 5.8 A when the irradiation is 800 w/m^2 . The pink line indicate the short circuit current 4.2 A when the irradiation is 400 w/m^2 . The purple line indicates the short circuit current 4.8 A when the irradiation level is 400 w/m^2 . The blue line indicates the short circuit current 1.5A when the irradiation level is very low approximately 200 w/m^2 . It is observed that the curves are shifted downward with decrease in Irradiance level.

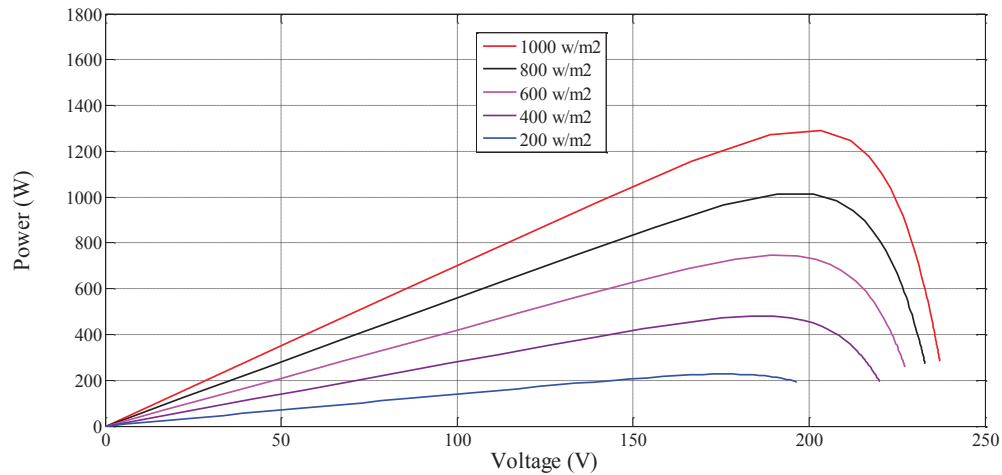

Fig. 3.9. P-V characteristic of the PV generator with different irradiance level

It is clear that the short circuit current I_{sc} is semi-linearly dependent on the irradiance level, although the change in the open circuit voltage V_{oc} is minor. Thus the output power at the Maximum Power Point (MPP) is increased as the irradiance level increased. The different color shows the different curve the PV generator at different irradiance level. More perfectly, the power increases in very large rate than the irradiance and it can be concluded that the efficiency is higher for high irradiance. In practice the irradiance on a PV device is lower, when light concentration is absent. So, the efficiency is usually lower than the rated Value [27].

3.3 Results of Simulation of the PV Generator

The scope block displays the output result with respect to the simulation time. The scope allow to adjust the amount of time and the range of the output value to display. The different scope characteristic with respect to time is given below.

3.3.1 Voltage versus Time Characteristic of PV Generator

The typical voltage versus time characteristic of the PV generator is shown in Fig. 3.10.

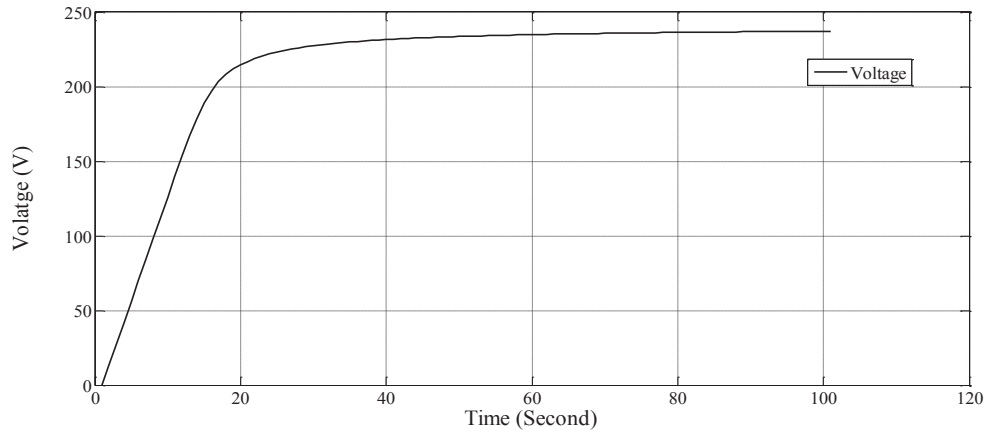

Fig. 3.10. Voltage versus time characteristic graph

The graph shows that the open circuit voltage V_{oc} is changes with time when the variable resistance is connected to the PV generator with a fixed 1000 w/m^2 irradiation level and constant temperature about 25° C . The black line show the increase in open circuit V_{oc} voltage from zero to maximum with respect to the simulation time

3.3.2 Current versus Time Characteristic of PV Generator

The typical voltage versus time characteristic of the PV generator is shown in Fig. 3.11. The graph shows that the short circuit current I_{sc} changes with time when the variable resistance is connected to the PV generator with a fixed 1000 w/m^2 irradiation level and constant temperature about 25° C . In the given graph the blue line indicates the decrease in short circuit current I_{sc} from maximum to zero point with respect to the time.

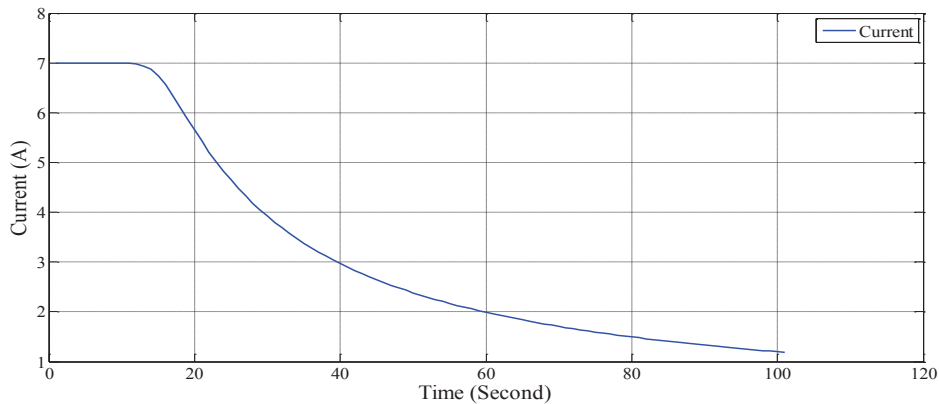

Fig. 3.11. Current versus Time characteristic graph

3.3.3 Power versus Time Characteristic of PV Generator

A typical Power versus Time characteristics graph of the PV generator is shown in Fig. 3.12.

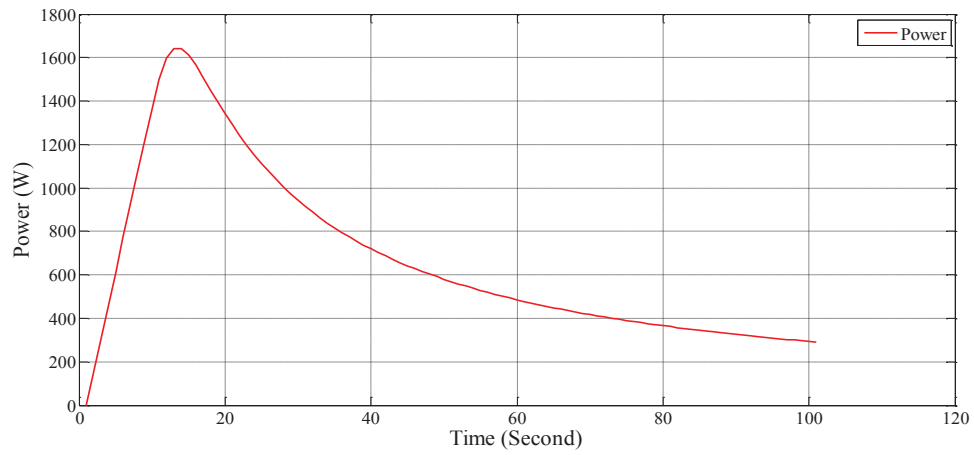

Fig. 3.12. Power versus Time characteristic graph

The power is the product of the voltage and the current ($V \cdot I$). The red line indicates that the power is changing with time when the variable resistance is connected to the PV generator with a fixed 1000 w/m^2 irradiation level and constant temperature about 25° C . This is the maximum power of the PV generator with constant irradiation level.

SIMULATION OF MAXIMUM POWER POINT TRACKER

As discussed in the previous chapter, PV generator have a single operating point where the values of the current (I) and voltage (V) of the generator result in a maximum power output. These values corresponding to the particular resistance, which is equal to V/I , as described by the Ohm's law. In the PV generator there is a combination of the PV cells and there PV cells have an exponential relation between the voltage (V) and current (I), therefore a one optimum point obtained which is known as Maximum Power Point (MPP) on the power voltage (P-V) curve which is discussed in the previous chapter. The MPP changes according to the radiation intensity and the PV cell temperature. In this chapter the complete discussion is based on the Maximum Power Point Tracking (MPPT) controller. A typical solar panel converts only 30 to 40 percent of the incident solar irradiation into the electric energy. The Maximum Power Point Tracking is the technique which is utilized to improve the efficiency of the solar panel.

According to the Maximum Power transfer theorem, the power output of the circuit is maximum when the source impedance is equal to or match with the load impedance.

4.1 Description of PV Generator Connected with DC-to-DC Converter and MPPT Controller

In this section the complete model of the PV generator which are connected with DC-to-DC converter including Perturbation and Observation block, Fuzzy logic block, battery system and then connected with the DC load are represented. In the PV generator there is total 400 cells which are connected in series and generate a voltage of 240 V and the current is 7A. The total output power of the generator is the product of voltage and current which is equal to the $240 \times 7 = 1680$ W. There are some abbreviations which are used in the diagram namely, V_{pv} stands for PV generator voltage, I_{pv} stands for PV generator current, P_{pv} stands for the PV generator power and the D stands for the duty cycle. The Maximum Power Point trackers (MPPTs) uses some control circuit or the logic circuit to reach the optimal point and thus allow the converter circuit to extract the maximum power available from the PV generator. In fact the peak power trackers optimize the operating voltage of the PV generator system to maximize the current. The positive and negative terminal of the PV generator is connected to the DC-to-DC power converter which is used to improve the output voltage so that it can be used for different application. The DC-to-DC converter is mainly used to regulate the unregulated voltage. The block diagram of the PV generator

connected with the DC-to-DC converters and Maximum Power Point Tracking (MPPT) controller is shown in Fig. 4.1.

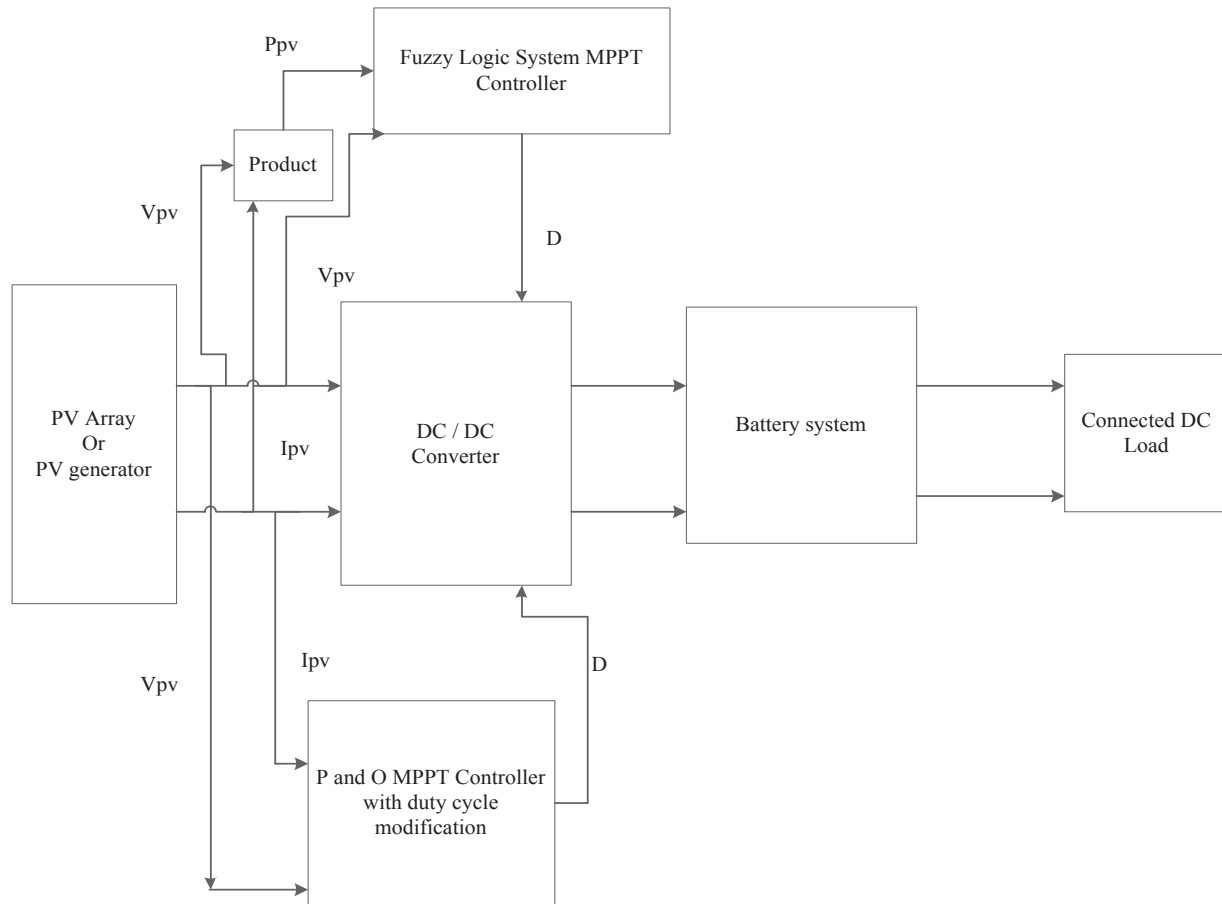

Fig. 4.1. Block diagram of the PV generator connected with the DC-to-DC converter and MPPT Controller

In the above discussion the MPPT is the method to let the controller operate at the optimum operating point. A Maximum Power Point Tracker (MPPT) is the explicit type of the charge controller that applied in the solar panel to its maximum potential. The MPPT compensates for changing the voltage against current characteristics of the PV generator. The Maximum Power Point Tracker (MPPT) monitor the output voltage and current from the PV array and it regulates the operating point that delivers the maximum amount of power available to the batteries or connected load [29].

4.2 Simulation of Photovoltaic Converters

As described in the introduction part, the Maximum Power Point Tracking (MPPT) is generally a load matching phenomena. In order to match the load resistance with changing input resistance of the panel by varying the duty cycle, a converter is required. An ideal converter should be able to supply the maximum power track from the PV device and then gives to the load. In case of stand- alone PV

generator the output voltage must be regulated to the desired value. In this section a different converter topology associated with the PV generator is discussed.

4.2.1 DC-to-DC Converter

The block diagram of a simple PV generator with DC-to-DC converter is shown in Fig. 4.2. In this figure the PV system composed to the PV generator including DC-to-DC converter, battery and the connected DC load are shown. This converter is a switching mode power conversion device. The DC-to-DC converter are used to control the output voltage across the load in case when the input voltage varies [26].

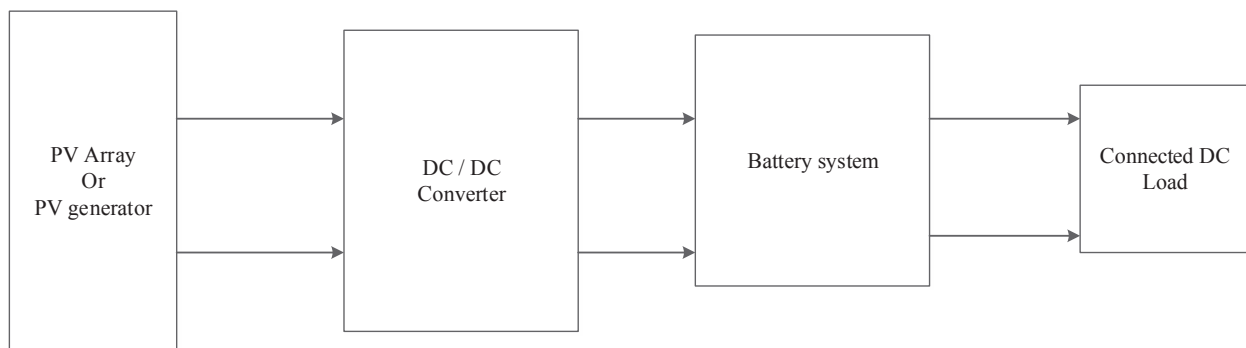

Fig. 4.2. Simple PV generator with DC-to-DC converter

A Maximum Power Point Tracker is a High efficiency DC-to-DC converter that functions as an optimum electrical load for a PV generator or array and converts the power to a voltage or current level that is more appropriate to whatever load the system is intended to drive. There is three different types of DC-to-DC converter which are used and discussed in the next section.

4.2.1.1 Buck Converter

The simplest form of the buck DC-to-DC converter is shown in Fig. 4.3. The element connected to the buck converters are an ideal switch, inductor, capacitor, diode and the resistive load.

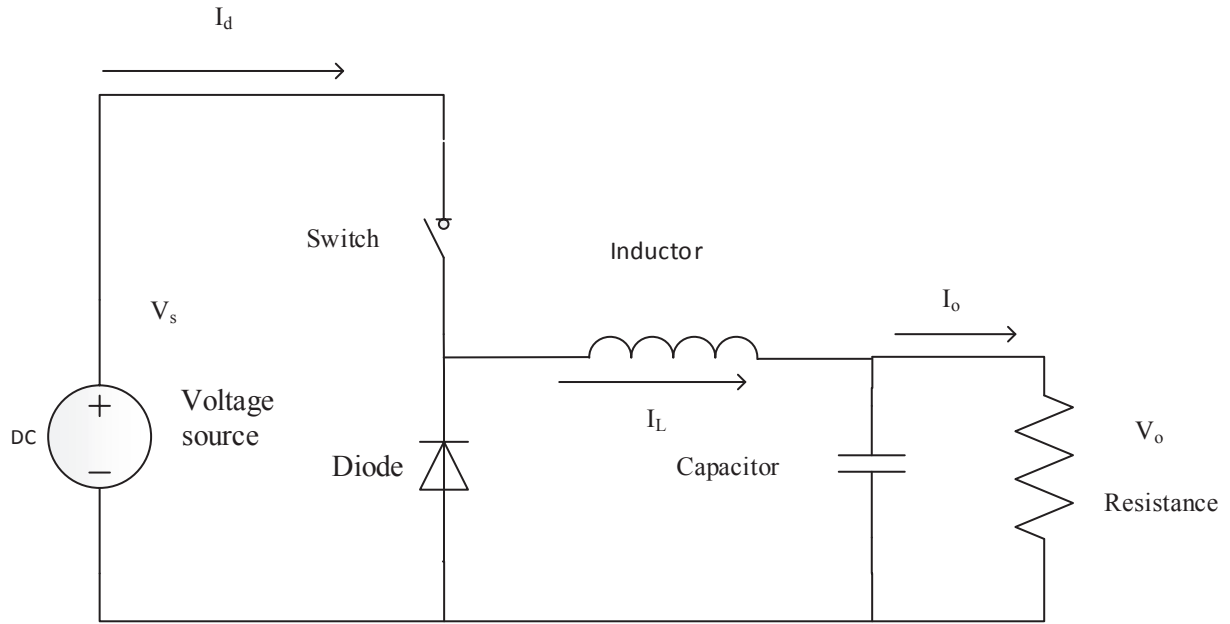

Fig. 4.3. DC-to-DC buck converter

During the on state mode of the switch the input voltage is supplied to the load and when the switch is off and the supply to the load is zero [30]. All the semiconductor switches used in circuit are considered to be an ideal.

The average output voltage of the converter is given below.

$$\frac{V_o}{V_s} = \frac{1}{(1-D)} \quad 4.1$$

Where V_o the output voltage that should be obtained, V_s is the input supply voltage of the converter and D is the duty cycle. The duty cycle should be calculated using the following equation.

$$D = \frac{T_{on}}{T} \quad 4.2$$

Where T_{on} the active time of the signal and the T is the total time period of the switching signal. The duty cycle D is the ratio of the active time of the signal to the total time period of the switching signal. The switching signal is generated from the MPPT controller technique which is discuss in the later section [30]. Therefore

$$V_o = D \cdot V_s \quad 4.3$$

Generally this output voltage have an undesirable harmonic in the converter to reduce this harmonic a filter circuit is required.

4.2.1.2 Boost Converter

In this work the boost converter is mainly used to boosts the output DC voltage to a value higher than the input DC voltage. The circuit diagram of the DC-to-DC boost converter is shown in Fig. 4.4.

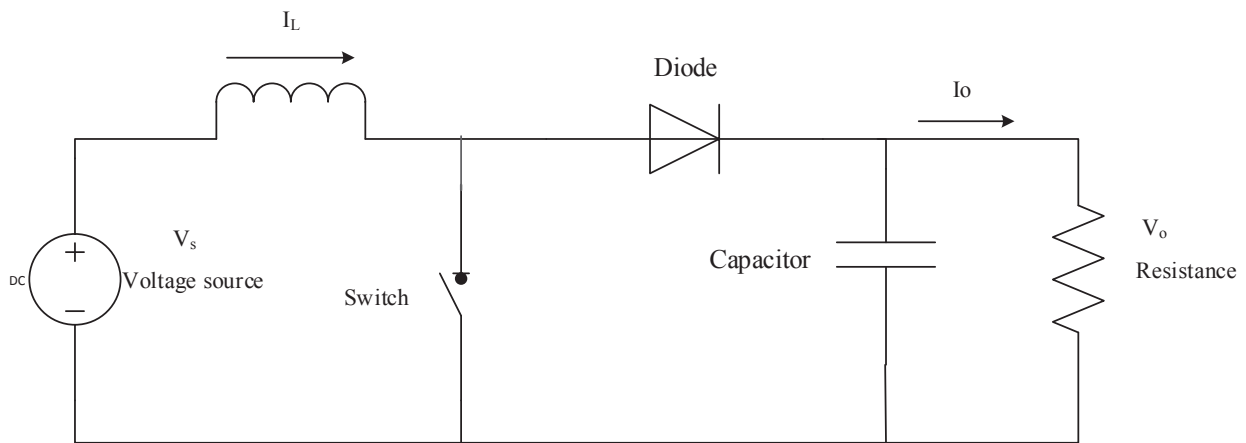

Fig. 4.4. . DC-to-DC boot converter

In the boost converter switching signal has a square shape with inactive and active period. The magnitude of the signal is in the form of the 0 and 1. In this circuit when the signal is active the inductor stores the magnetic energy and the amount of the energy is depended upon the active time of the signal. The signal is generated from the technique which are used to find the Maximum Power Point (MPP) methods known as Perturb and Observe method and fuzzy logic control method. Ther both method is discussed in the next section [31].

In the second part which, signal is inactive then the switch is in open circuit mode then the inductor produces the back electromagnetic field in opposite polarity of the voltage during the active period. In this case two voltages are produced, one is the input voltage coming from the PV generator added to the voltage across the inductor and the second voltage across the load which is higher than the input voltage. Therefore this converter is also known as step up voltage converter. The suitable values of the inductance and proper capacitance of the converter is necessary to reach the system suitable at different level of irradiation. The minimum value of inductance and capacitance value can be calculated as given below.

a) Selection of the inductor (L) – The inductor is selected based on the maximum permitted ripple current when the duty cycle is minimum, D and the input voltage is maximum, V_s . the converter is in continuous conduction mode for the value of the inductance(L) which is greater than the critical inductance(L_b).the formula for minimum inductance is given below

b)

$$L_b = \frac{(1-D)^2 * D * R}{2F_s} \quad 4.4$$

Where L_b is the critical inductance, explained as the inductance at the limit edge between the discontinuous and continuous mode of the converter, F_s is the switching frequency of the ideal switch which is equal to 50 kHz. R is the load resistance.

c) Selection of the capacitor(C) - The large capacitance is required to reduce the ripples in the output voltage .The current which is supply to the RC filter circuit is discontinuous. The formula required to select the minimum value of the filter capacitor that delivers the output DC current to the load when the diode D is in off position is given below

$$C_{min} = \frac{V_o * D}{F_s * \Delta V_o * R} \quad 4.5$$

Where ΔV_o is the ripple output voltage of the converter which is mainly select in the range of 5% less than the output voltage, R is the load resistance is the duty cycle which is generally considered as 0.592 [31].

4.3 Maximum Power Point Tracking (MPPT) Controller

The Maximum Power Point tracking (MPPT) is technique which is generally used to increase the efficiency of the PV generator with respect to varying weather condition. The principle of the MPPT controller of the PV generator is dependent on the load characteristic. With varying the weather condition the optimal variation occurs on at on specific operating point known as Maximum Power Point (MPP). When there is a direct connection between the PV generators and load then output of the PV generator is maximum but it is not optimal. So to overcome this problem it is necessary an additional device, MPPT controller connected with a DC-to-DC converter between the source and the variable load resistance to make the system optimal. The MPPT controller also tracks a new modified curve

whenever the irradiation and the temperature variation occurs. The conventional MPPT method have some drawbacks in terms of efficiency, flexibility and accuracy.

4.3.1 Different Types of MPPT Techniques

There are some different techniques which are used to track the maximum power are given below

- a) Perturbation and Observation method or (P & O method)
- b) Incremental conductance method
- c) Voltage control feedback method
- d) Current control feedback method
- e) Fuzzy logic control (FLC) method

All of the above method is depend on the time of complexity to track the Maximum Power Point (MPP), implementation cost and ease of installation.

In the present scenario only two method is implemented which is mostly used now a days and make the PV generator system more efficient. Here only two methods are discussed is in detail which is mostly used and easy to install.

4.3.1.1 Perturbation and Observation method

In the modern time due to the simplicity and generic nature the Perturbation and Observation method are mostly used to track the MPP. The principle of this controller is to aggravate perturbation by performing (increasing and decreasing) on the duty cycle and observe the effect of output of the PV generator power. In this method only one sensor is used known as voltage sensor to sense the PV generator voltage, so the cost of implementation is less and easy to install and less maintenance. This method is based on the fact that the derivative of the power with respect to voltage is zero at MPP. This method is also known as the hill climbing method due to which the power- voltage curve have only one peak value over the range of the voltage [32]. The time of complexity of this method is very less but reaches very close to MPP and it doesn't stable at Maximum Power Point (MPP) and keeping on perturbing in both the directions. This will happen due to changing the weather condition so the sensor voltage will change and the optimal point increase or decrease on both the sides. If at any instant t_1 , the output power $P_{PV}(t_1)$ & voltage $V_{PV}(t_1)$ are greater than the earlier power then the perturbation is maintained otherwise it is inverted. The algorithm of the Perturbation and Observation controller method is given in Fig. 4.5 as shown below

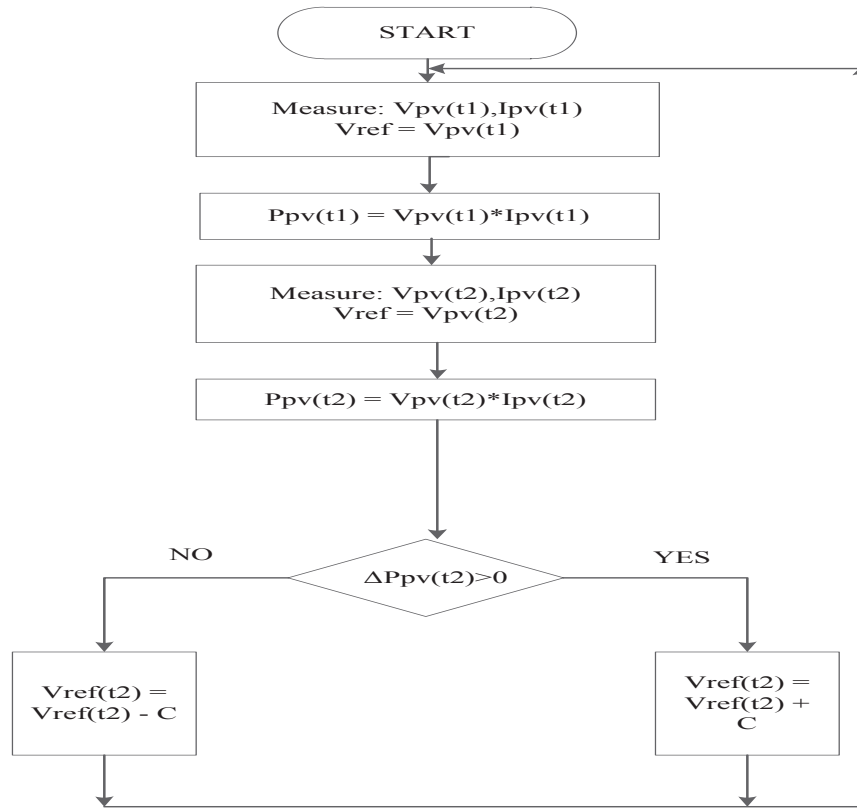

Fig. 4.5. Algorithm of the Perturb and Observe method

At the operating point on the power - voltage curve of the PV generator, if the derivative of power with respect to voltage $dP > 0$ then there is increment in the power then the Perturbation moves the operating point toward the MPP and it is done through $V_{ref}(t2) = V_{ref}(t2)+C$ and if the derivative of power with respect to voltage $dP < 0$ then there is decrease in power and perturbation moves the operating point away from the MPP or opposite direction and it is done through $V_{ref}(t2) = V_{ref}(t2)-C$. If the $dP = 0$ then the perturb is stable and observe operating point is a Maximum Power Point (MPP) which is shown in Fig. 4.6 in the Power-Voltage curve. The Maximum Power Point trackers used different types of the control circuit or the logic to search for this operating point to permit the converter circuit to extract the maximum power available from the PV generator. The block diagram of the Perturb and Observe method controller connected with DC-to-DC converter as shown in Fig. 4.1.

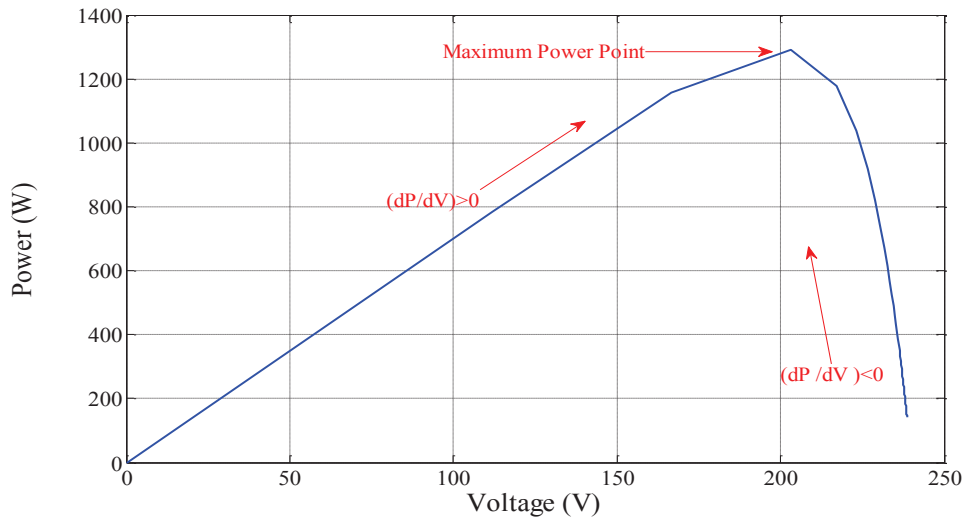

Fig. 4.6. Power versus Voltage curve of PV generator

The output taken from the Perturbation and Observation is in the form of Duty cycle. The duty cycles is given to the ideal switch of the DC-to-DC converter which will gives the maximum power output of the PV generator. This process is recurring until the MPP is reached. The operating point is fluctuating around the MPP. So to overcome this fluctuation the around the artificial intelligent based Fuzzy Logic control (FLC) method is used. The perturbation change the duty cycle of the converter and then detecting the direction of change of PV output. The duty cycle change graph is shown in Fig. 4.7. The red line shows the change in duty cycle with respect to the time. The duty cycle change with the comparison of derivative of power with the respect to power in the weather condition.

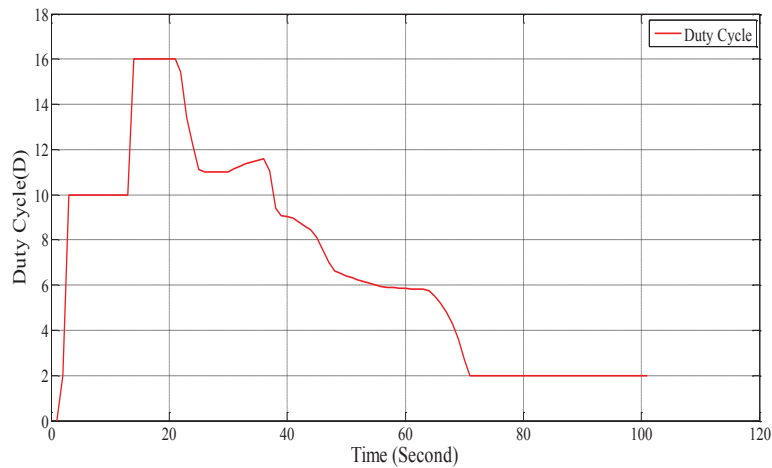

Fig. 4.7. Duty cycle versus Time graph

The output voltage graph of the PV generator with or without Perturb and Observe MPPT controller is shown in Fig. 4.8 and Fig. 4.9.

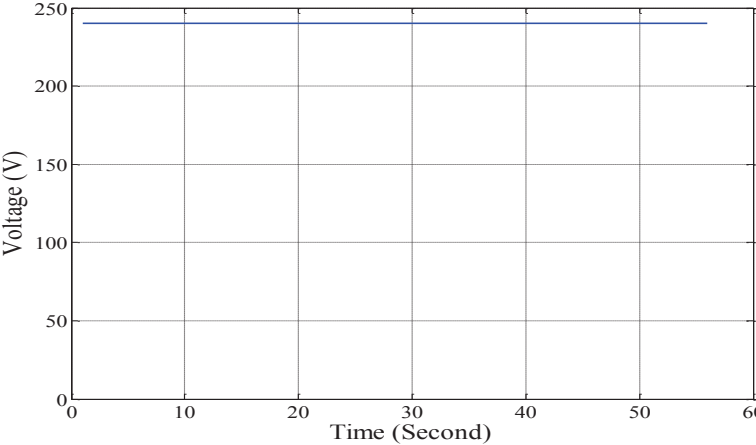

Fig. 4.8. Output voltages of PV generator without P and O controller

In the above Fig 4.8 the voltage is shown when there is no converter connected with PV generator system to control the maximum power output.

The blue line shows the output voltage of the PV generator when there is no MPPT controller is connected to the system [33].

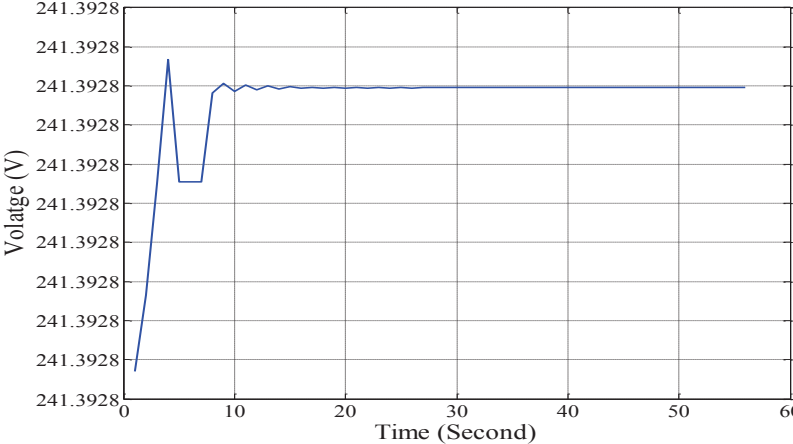

Fig. 4.9. Output voltages of PV generator with P and O controller [34]

The blue line in the above figure shows the improved output voltage of the PV generator when the Perturb and Observe connected with the converter and the resistive load connected to it and changes

according to the weather condition. The main significance of the Perturb and Observe method is to increase the efficiency of the PV system and obtaining the maximum power from the PV system to connected load. Its time of complexity is less but the operating point oscillates around the MPP so the FLC method is preferred which is discuss in the next section.

4.3.1.2 Fuzzy Logic Control (FLC) Method

There are different methods which are used to track the Maximum Power Point (MPP) of the PV generator. In this section the artificial intelligence based Fuzzy logic control (FLC) technique is used to track the Maximum Power Point (MPP) of the PV generator with the help of varying irradiation of the solar system. The advantage of the FLC system is easy to design and can be assumed, no need of accurate mathematical equations and executed with the control theory. The most important advantage of fuzzy logic controller (FLC) method is that the output has minimum oscillation with fast convergence around the desired MPP. The performance of this method is better under the sudden change in the irradiation of the system. In the fuzzy logic controller (FLC) there are three stages namely fuzzification, inference and defuzzification which are describe in the block diagram as shown in Fig. 4.10 [31].

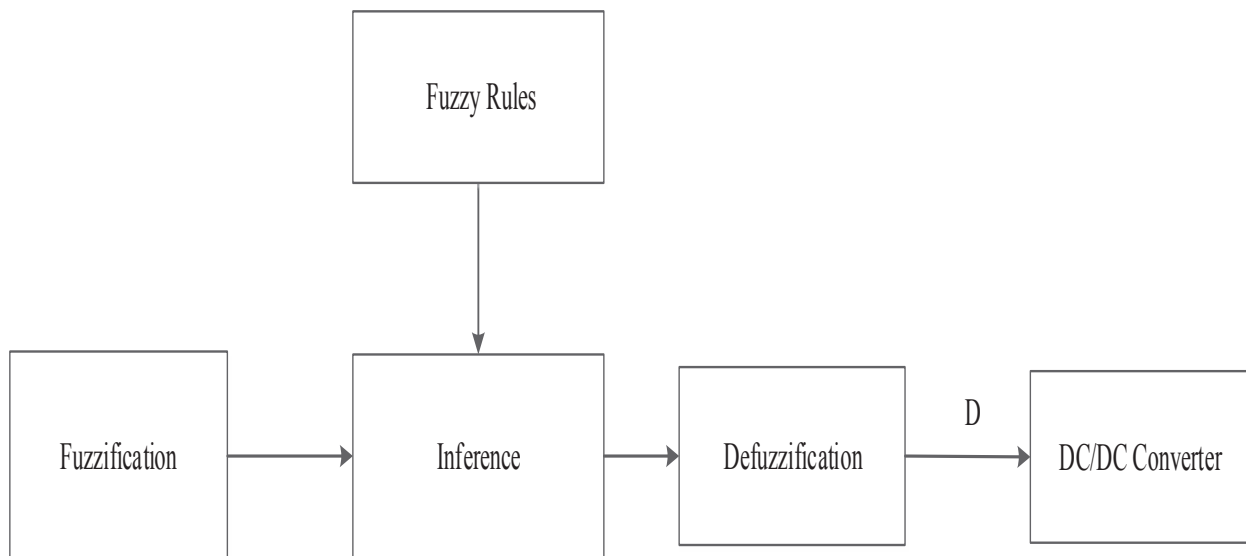

Fig. 4.10. Block diagram of fuzzy logic control (FLC) system

In the fuzzification the fuzzy logic control (FLC) system requires the input and output variable which are expressed in the linguistic level. The linguistic values of each input and output variables split its universe of discourse into adjacent intervals to form the membership functions. The member value represents the level to which a variable belong to a specific level. The process of changing input/output variable to linguistic levels is called as Fuzzification [34].

In the inference the different rules are defined with respect to the input and output variables of the membership functions. When a set of input variables are read each of the rule that has any degree of truth in its statement is excited and donates to create of the control surface by nearly adjusting it. When all the rules are excited, the subsequent control surface is stated as a fuzzy set to represent the restraints output. This process is termed as inference.

The defuzzification is the process which is used to convert the fuzzy quantity to the crisp value. The centroid method is mostly used for the defuzzification. This crisp value are represents the duty cycle of the switching signal that triggers the ideal switch of the DC-to-DC converter.

The fuzzy logic control system are represented in the MATLAB/Simulink software. In the MATLAB/Simulink write the “fuzzy” in the command window and the fuzzy system window will be appear in which there is a Mamdani-type system with two inputs and one output has been established. The Schematic diagram of fuzzy logic system are shown in Fig. 4.11 in which the membership function with triangular shape have been used. In the figure there are two inputs. The input P represents the power and the input ΔV represents the change in voltage of the PV generator and one output D represents the duty cycle which will generate the control signal to the converter of the PV generator.

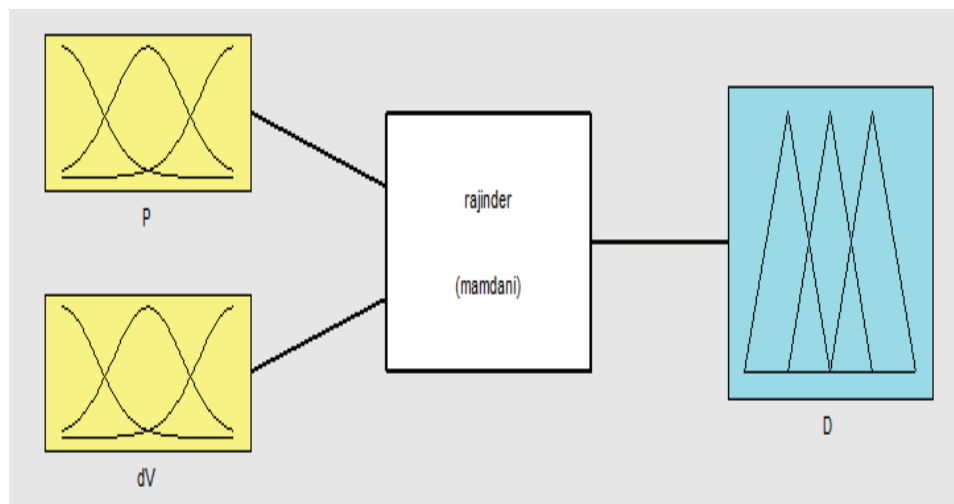

Fig. 4.11. Schematic diagram of fuzzy logic system

The different range of the signals are decided based on the simulation data. In this work the input and output signals are represented into different subsets: Very Low (VL), Low (L), Medium (M), High (H) and Very High (VH). The representation of the input power signal with triangular shape member ship function is shown in Fig. 4.12.

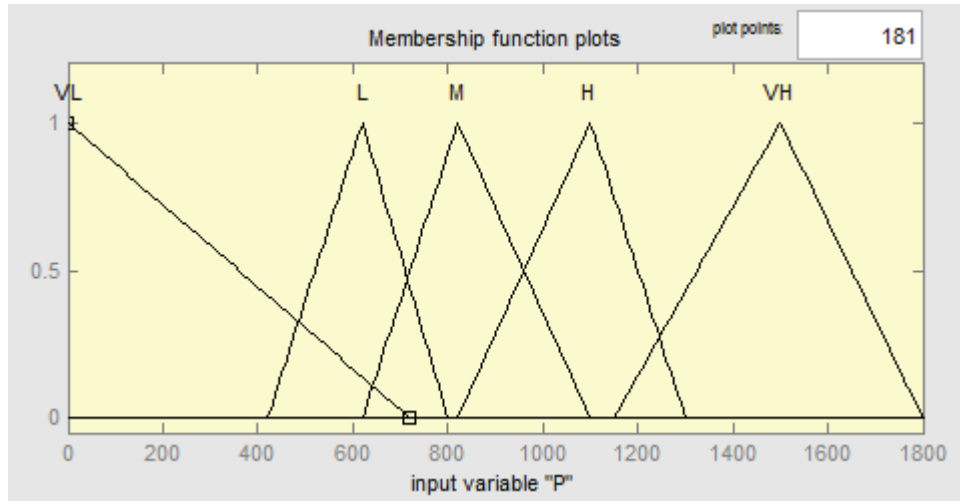

Fig. 4.12. Input Power (P) signal of fuzzy system

The different range of the power will be described with the triangular shape. The degree of membership function is always varies from 0 to 1 show in the vertical line.

The change in voltage ΔV is the ripple voltage which is 5% of the total output voltage of the PV generator input membership function is shown in Fig. 4.13.

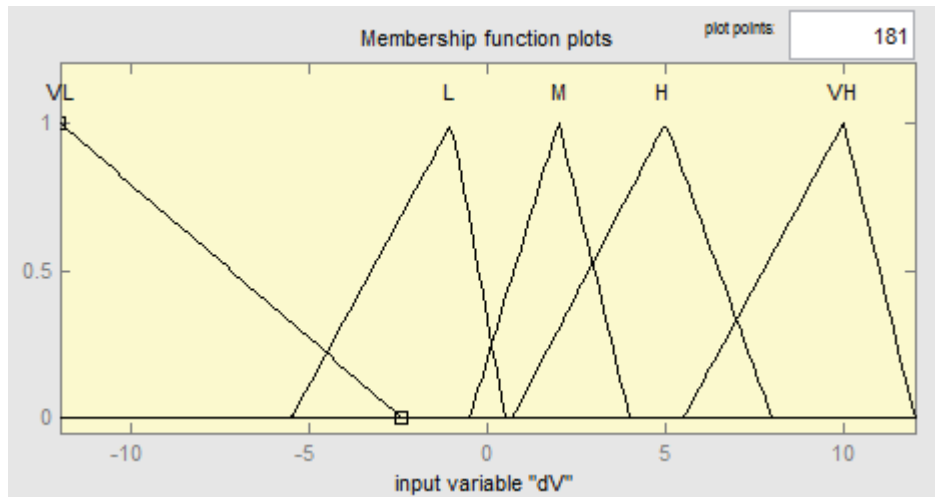

Fig. 4.13. Change in input voltage ΔV signal of fuzzy system

The range of this membership function is also described in the form of the triangular shape. The change in voltage will vary according to the weather condition.

The output of the membership function is described in the form of the duty cycle signal is shown in Fig. 4.14.

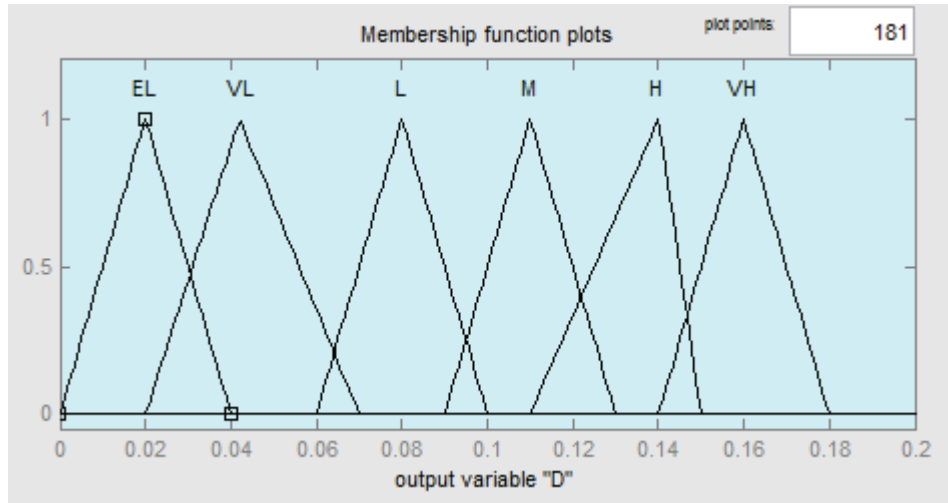

Fig. 4.14. Duty cycle output signal of fuzzy system

With the help of the input and output membership function the rule table is created according to the power and change in voltage ΔV of the PV generator as shown in table 4.1. Simulation data exposes the projected output at different value of inputs depending on some relation and then the rules have been determined according to this relation. In this work, five subsets of each input and the twenty five rules has been used [34].

Table 4.1. Rules of fuzzy logic system

$\Delta V/P$	VL	L	M	H	VH
VL	EL	VL	M	H	VH
L	EL	VL	H	H	VH
M	EL	M	M	M	VH
H	EL	M	H	M	VH
VH	EL	L	M	H	VH

The each input value of the fuzzy logic controller is compared with twenty five rules of the system and are associated with the membership function. The implication has been done through the “and” operator. The different types of mamdani rules are given below:

- a) If (ΔV is VL) and (P is VL) then (D is EL)
- b) If (ΔV is VL) and (P is L) then (D is VL)
- c) If (ΔV is VL) and (P is M) then (D is M)
- d) If (ΔV is VL) and (P is H) then (D is H)
- e) If (ΔV is VL) and (P is VH) then (D is VH)
- f) If (ΔV is L) and (P is VL) then (D is EL)
- g) If (ΔV is L) and (P is L) then (D is VL)
- h) If (ΔV is L) and (P is M) then (D is H)
- i) If (ΔV is L) and (P is H) then (D is H)
- j) If (ΔV is L) and (P is VH) then (D is VH)
- k) If (ΔV is M) and (P is VL) then (D is EL)
- l) If (ΔV is M) and (P is L) then (D is M)
- m) If (ΔV is M) and (P is M) then (D is M)
- n) If (ΔV is M) and (P is H) then (D is M)
- o) If (ΔV is M) and (P is VH) then (D is VH)
- p) If (ΔV is H) and (P is VL) then (D is EL)
- q) If (ΔV is H) and (P is EL) then (D is M)
- r) If (ΔV is H) and (P is M) then (D is H)
- s) If (ΔV is H) and (P is H) then (D is M)
- t) If (ΔV is H) and (P is VH) then (D is VH)
- u) If (ΔV is VH) and (P is VL) then (D is EL)
- v) If (ΔV is VH) and (P is L) then (D is L)
- w) If (ΔV is VH) and (P is M) then (D is M)
- x) If (ΔV is VH) and (P is H) then (D is H)
- y) If (ΔV is VH) and (P is VH) then (D is VH)

After the implication, a surface view is formed showing relation between the fuzzy input and output as shown in figure 4.15. After the relation between input and output membership function of the fuzzy logic system, a duty cycle signal is formed but the simulated model requires the crisp value from the fuzzy logic system then the defuzzification is done with the help of centroid method and changes the signal to crisp value. This crisp value is given to the DC-to-DC converter through the ideal switch to track the Maximum Power Point (MPP) which is shown in the block diagram in Fig. 4.1.

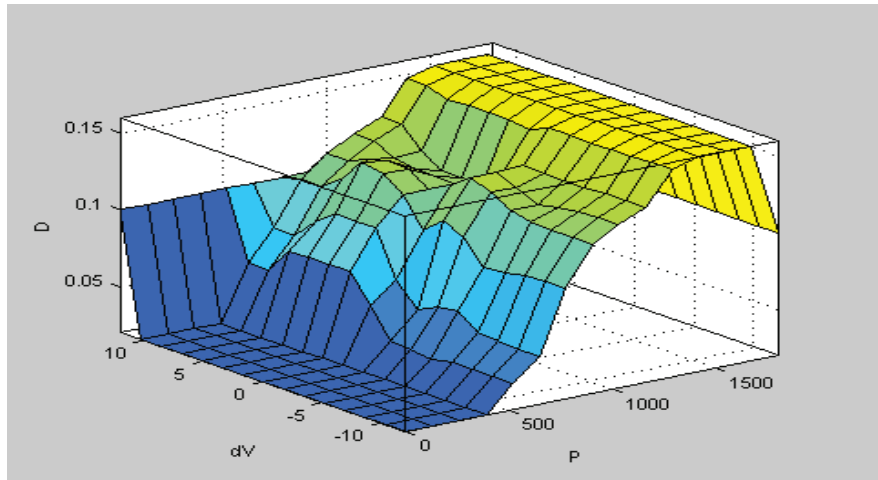

Fig. 4.15. Surface view for the fuzzy logic inputs (P, ΔV) Vs output (D)

The duty cycle of the fuzzy logic control system which change according to the mamdani rules is shown in figure 4.16. The red line shows the duty cycle which is varying with the different rules.

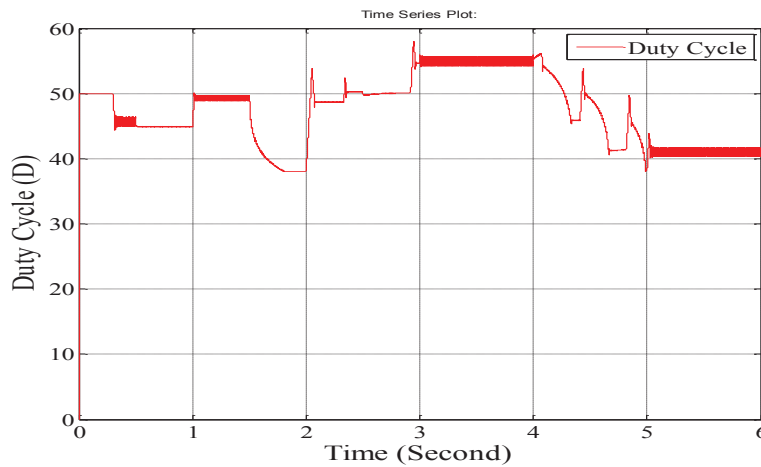

Fig. 4.16. Duty cycle versus Time graph of FLC system

The improved output voltage of the PV generator with the help of fuzzy logic controller is shown in Fig. 4.17.

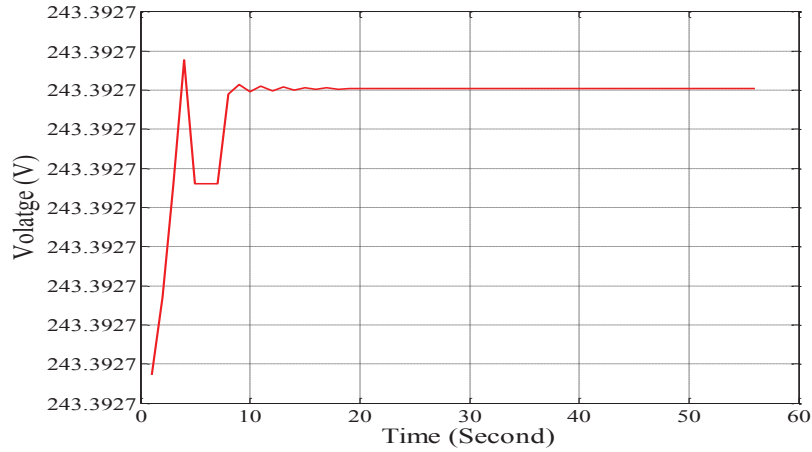

Fig. 4.17. Output voltages with PV generator with fuzzy logic controller

Due to changing the crisp value of the fuzzy logic controller then the output voltage of the PV generator changes because of variation in the irradiation level [31]. After this changes a one operating point is obtained at which the irradiation level is constant around 1000 w/m^2 in full sunlight and the temperature is 25°C then the output voltage of the PV generator is stable or constant as indicated with the red line in the above Fig.4.17.

CONCLUSION AND FUTURE SCOPE OF WORK

5.1 Conclusion

The presented work is mainly about the study of the modeling of the photovoltaic generator connected with the variable load resistance. In this research work two different techniques are implemented namely Perturbation and Observation method or the fuzzy logic control (FLC) method to track the maximum power from the PV generator with the variation of the temperature and the irradiance. It is seen that the efficiency of the PV generator increase by using these method. The I-V characteristic and P-V characteristic of the PV generator is obtained with the variation of irradiation. The contribution of this research is to implement the different MPPT controller method to control the output voltage of PV generator with the help of DC-to-DC converter. The converter output voltage of the PV generator is drawn with MPPT controller and without MPPT controller. The simulation method applied using MATLAB- Simscape software is highly suggested to investigate the performance of the PV generator at the stage of research and development to justify the robustness of the proposed system and reducing the R&D cost prior to onsite installation of the real system.

5.2 Future Scope of Research

The future scope of present research work is identified as

- a) To implement the shading and partial shading effect of the PV generator with variable load.
- b) To find maximum Power Point of the PV generator with the help of different techniques and control the output voltage of PV generator by using converters.

BIBLIOGRAPHY

- [1] K. N. a. L. B, "Sustainable rural electrification in Thailand:analysis of energy consumption and CO2 emissions," in *International Conference and Utility exhibition on Green Energy for Sustainable Development*, Pattaya, Thailand, 2014.
- [2] Z. S. Y. W. Yunchang S., "Development situation and policy suggestion of Chinese renewable energy," in *International Conference on Materials for Renewable Energy & Envirnoment (ICMREE)*, Shanghai, 2011.
- [3] T. Ackermann, "Introduction," in *Wind power in Power Systems*, 2nd edition, United Kingdom: Wiley, 2012, pp. 1-2.
- [4] US Energy Consumption. Available at <http://www.eia.gov>. Accessed 28 February 2015.
- [5] M.-L. C.-C. H. a. J.-R. L. Chiang, "Direct power control for distributed PV power system," in *Power Conversion Conference*, PCC-Osaka , 2002.
- [6] Y. Yusof, "Modeling and simulation of maximum power point tracker for photovoltaic system," in *Power and Energy Conference*, PEC, CHD, 2004.
- [7] C. Meza, "Boost-buck inverter variable structure control for grid-connected photovoltaic systems," *ISCAS*, pp. 1318-1321, 2005.
- [8] A. a. M. J. A. Tariq, "Development of an analog maximum power point tracker for photovoltaic panel," in *Power Electronics and Drives Systems international conference on vol.I*, 2005.
- [9] F. Luo, "A variable step maximum power point tracking method using differential equation solution," in *ICIEA*, Aligarh, 2007.
- [10] D. Dondi, "Photovoltaic cell modeling for solar energy powered sensor networks," in *nternational Workshop on Advances in Sensors and Interface (IWASI)*, 2007.
- [11] N. El-Gohary, "Maximum power point tracking technique for microsatellite power supply system," in *Radio Science Conference (NRSC)*, 2008.

- [12] S. C. S. P. Chowdhury, "Mathematical modelling and performance evaluation of a stand-alone polycrystalline PV plant with MPPT facility," *Power and Energy Society General Meeting-Conversion and Delivery*, pp. 1-7, 2008.
- [13] J.-S. Choi, "Tracking system and MPPT control for efficiency improvement of photovoltaic," in *Control, Automation and Systems, ICCAS*, seoul, korea, 2008.
- [14] T. a. H. K. Arayashiki, "A simulation method for maximum power point tracking against stepped I-V characteristics," in *Sustainable Energy Technologies , ICSET*, 2008.
- [15] Y. a. W. X. Zhihao, "Compensation loop design of a photovoltaic system based on constant voltage MPPT," in *Power and Energy Engineering Conference, Asia-Pacific*, 2009.
- [16] L. Hongpeng, "The maximum power point tracking based on the double index model of PV cells," in *Power Electronics and Motion Control Conference*, 2009.
- [17] R. B. L. M. a. M. S. Ramaprabha, "Solar array modeling and simulation of MPPT using neural network," in *Control, Automation, Communication and Energy Conservation INCACEC*, 2009.
- [18] M. G. J. R. G. a. E. R. F. Villalva, "Analysis and simulation of the P&O MPPT algorithm using a linearized PV array model," in *10th Brazilian Power Electronics Conference*, 2009.
- [19] T.-C. a. T.-S. C. Yu, "Analysis and simulation of characteristics and maximum power point tracking for photovoltaic systems," in *Power Electronics and Drive Systems*, 2009.
- [20] R. Sridhar, "Performance improvement of a photo voltaic array using MPPT (P&O) technique," in *Communication Control and Computing Technologies (ICCCCT)*, 2010.
- [21] F. A. O. a. F. V. P. R. Aashoor, "Maximum power point tracking of photovoltaic water pumping system using fuzzy logic controller," in *Power Engineering Conference (UPEC)*, 2013.
- [22] P. S. C. a. S. P. C. ". Basak, "Simscape based modeling and simulation of a PV generator in microgrid scenario," in *CIREN*, Stockholm, 2013.

- [23] D. Abbes, "Modeling and simulation of a photovoltaic system: An advanced synthetic study," in *Systems and Control (ICSC)*, Algeria, 2013.
- [24] E. Dallago, "Direct MPPT algorithm for PV sources with only voltage measurements," in *ICSC*, Algeria, 2015.
- [25] J. R. G. M. G. Villalva, "Comprehensive approach to modeling and simulation of photovoltaic arrays," *Power Electronics*, vol. 24, pp. 1198-1208, 2009.
- [26] A. M. Said.Sameer, "A Matlab/Simulink based photovoltaic array model employing SimPowerSystems toolbox," *Journal of Energy and Power Engineering*, vol. 6, pp. 1965-1975, 2012.
- [27] A. D. Theocharis, "Equivalent circuit of photovoltaic generator using Newton-Raphson algorithm," *COMPEL-The international journal for computation and mathematics in electrical and electronic engineering*, vol. 31, no. 4, pp. 1224-1245, 31 April 2012.
- [28] D. a. E. M. Rekioua, *Optimization of photovoltaic power systems: modelization, simulation and control*, Springer Science & Business Media, 2012.
- [29] M. G. a. D. P. S. R. Venkateswarlu, "Simscape model of photovoltaic cell," *International Journal of Advanced Research in Electrical, Electronics and Instrumentation Engineering*, vol. 2, 2013.
- [30] U. M. D. S. a. D. T. Patel, "Maximum power point tracking using perturb & observe algorithm and compare with another algorithm," *International Journal of Digital Application & Contemporary research*, vol. 2, no. 2, 2013.
- [31] R. K. Kharb, "Modeling of solar PV module and maximum power point tracking using ANFIS," *International Journal of Advanced Research in Electrical*, vol. 3, no. 1, pp. 602-612, 31 April 2014.
- [32] A. A. K. B. a. M. A.-K. Allataifeh, "Maximum Power Point Tracking Using Fuzzy Logic Controller under Partial Conditions," *Smart Grid and Renewable Energy*, vol. 6, no. 1, 2015.

- [33] R. A. S. a. S. G. Garg, "PV cell models and dynamic simulation of MPPT trackers in MATLAB," in *Computing for Sustainable Global Development (INDIACom)*, 2014.
- [34] M. S. A. a. E. S. Srivastava, "Design and Simulation of Perturb and Observe MPPT Algorithm for 72 Cell Solar PV System," *International Journal of Soft Computing and Engineering (IJSCE)*, vol. 4, no. 6, 2015.
- [35] S. P. R. a. D. D. Karthika, "Fuzzy logic based maximum power point tracking designed for 10kw solar photovoltaic system," *International Journal of Computer Science and Management Research*, vol. 2, no. 2, 2013.