

**PERFORMANCE ANALYSIS OF TYRE MOUNTING HUB LEAKAGE IN JCB
ROBOT 135 MACHINE**

*Thesis Submitted in partial fulfillment of the requirement for
The award of the degree of
Masters of Science
In
Mathematics and Computing*

Submitted by
Jyoti Singh
Reg. No. 301503010

Under the guidance of
Dr. A.K. Lal



**School of Mathematics
Thapar University
Patiala-147004 (PUNJAB)
INDIA
July, 2017**

CERTIFICATE

I hereby certify that the dissertation entitled, “**Performance Analysis of Tyre Mounting Hub Leakage in JCB Robot 135 Machine**” which is being submitted by **Ms. Jyoti Singh** (Roll No. 301503010), in the partial fulfillment of the requirement for the award of the degree of Master of Science in the School of Mathematics, Thapar University, Patiala, comprises of candidates own research work carried out under the supervision and guidance of Dr. A.K. Lal during the period from January 2017 to July 2017. The part of the work presented in this dissertation has not been submitted either in part or in full to this or any other University/Institute for the award of any degree.

Jyoti Singh
(301503010)

This is to certify that the above statement made by the candidate is correct and true to the best of my knowledge.



Dr. A.K. Lal

Supervisor

Associate Professor and Head

School of Mathematics

Thapar University, Patiala

ACKNOWLEDGEMENT

I would like to thank to all the people who have supported and helped me so much throughout this period.

First of all, I offer my sincerest gratitude to my respected supervisor, **Dr. A.K. Lal, Associate Professor and Head, School of Mathematics, Thapar University, Patiala**, who has supported me, inspired me throughout my thesis with his patience and knowledge. His guidance helped me in all the time of research and writing of this thesis.

I cannot write name of each of my friend but I would like to thank all my friends. I feel blessed to have all of you in my life.

Above all, I would like to thank my father and mother for their love, blessings, support, sacrifice and unwavering belief in me. You are always there for me in every good and bad moments. And a big thanks to my brother and sister, they always give inspiration to me for doing good work. Thank you for being there for me.

Thank you everyone!!

Jyoti Singh
(301503010)

Abstract

The name *Reliability* is given to the field of study that attempts to assign numbers to the propensity of a system to fail. It is observed that, most of the times a system fails due to human error. In a more restrictive sense, the term reliability is defined to be the probability of a system performing its mission successfully. Reliability is a function of time. The main aim of any manufacturing industry is to produce reliable items that work under stated conditions without failure. So, a performance study of manufacturing industries is the basic need of time in order to improve production process. Some of the manufacturing systems such as plastic pie, butter-oil manufacturing plant, chemical plant, piston manufacturing plant have earlier considered for their reliability and availability analysis. However, the performance analysis of tyre mounting hub leakage in JCB Robot 135 machine has not been studied so far.

In this Thesis, definition and basic concepts of reliability have been discussed. A brief introduction to the Industry JCB India Pvt. Ltd. is given and We have defined the problems of the machine which the industry actually faces. The Mathematical formulation of one of the problems is carried out using Markov-Method. The Chapman-Kolomorgov differential equations are solved using Runga-Kutta Fourth order method to find out the reliability for various choices of failure and repair rates of the sub-systems. The availability of the system is calculated by solving the system of linear equations using Gauss elimination method. The effect of failure and repair rates on the reliability and availability have been studied in detail with the help of graphs and tables.

Based on the present study, conclusions have been presented in the end.

Contents

Abstract	ii
1 INTRODUCTION	1
1.1 Literature Review	2
1.2 Definitions and basic concepts	3
1.3 Summary of the present work	7
2 BEHAVIOUR ANALYSIS OF TYRE MOUNTING HUB LEAKAGE IN JCB ROBOT 135 MACHINE	9
2.1 JCB Robot 135	10
2.2 Defining the problem	11
2.3 System and Notation	13
2.4 Assumptions for the sub-system R1	14
2.5 Mathematical Model of Tyre Mounting Hub Leakage	16
2.6 Behaviour Study	17
2.7 Analysis of Results	21
3 AVAILABILITY MODEL OF TYRE MOUNTING HUB LEAKAGE SYSTEM	24
3.1 Mathematical Formulation	24
3.2 Numerical Analysis	25
3.3 Analysis of Results	27
3.4 Concluding Observations	27
3.4.1 Industrial Significance of this study	27
3.4.2 Limitations and Future scope of the present study	27
References	29

List of Figures

- 1.1 Series Configuration 5
- 1.2 Parallel Configuration 6
- 1.3 Complex System 7

- 2.1 Pictorial View of steps of testing 12
- 2.2 Flow Chart of Tyre Mounting Hub Leakage 14
- 2.3 Transition Diagram for Sub-system R1 15
- 2.4 Graph 2.1 22
- 2.5 Graph 2.2 22
- 2.6 Graph 2.3 23
- 2.7 Graph 2.4 23

Chapter 1

INTRODUCTION

The name Reliability is given to the field of study that attempts to assign numbers to the propensity of systems to fail. Reliability has gained increasing importance in the last few years in the industries, government communities. Everyone is interested in purchasing the products which have higher reliability and lower maintenance cost. As consumers, we are mainly concerned with buying products that have longer life and cheaper maintenance. Companies are forced to analyze the manufacturing system's performance in the terms of reliability and availability. The reliability analysis is the basic way to establish first and to improve after the efficiency of complex systems.

The Reliability of a system defined as probability that a system will perform a required function for a certain period of time under stated conditions. Failure is certain for everything from which machines, devices or instruments are no exception. These failures are caused due to poor maintenance, bad engineering design, inadequate testing, improper use and there are other reasons too that are causing failures. This analysis is an analytical problem which is dealing with engineering aspects and statistical problems. In the present work, we have chosen JCB's one of the model, JCB Robot 135 and discuss the reliability and availability of tyre mounting hub leakage which is one of the problem industry facing in the respective machine.

This chapter contains the following: Literature survey is discussed in section 1.1. Definitions and basic concepts which are important to study the reliability and availability of the system are discussed in section 1.2. In the next Section, summary of the present work is discussed.

1.1 Literature Review

Growth of reliability has been motivated by various factors including the increased complexity and sophistication of systems and insistence on product quality. New laws and regulations concerning product liability, government contractual requirements to meet reliability, performance, specifications and profit considerations resulting from the high cost of failures, their repairs and warranty programs. The probabilistic theory of reliability has grown out of the experiences in World War II with complex military systems. Complexity and automation equipment used in the war resulted in several problems of maintenance and repair. 'Life testing', 'electronic and missiles reliability' are the problems started to receive a great deal of attention from both statisticians and engineers in early 1950.

In 1952, the US Department of Defence had established the Advisory Group on Reliability of Electronic Equipment (AGREE). This group published its first report on reliability in 1957. Davis (1952) discussed failure data and goodness of fit tests for various competing failure distributions. Dummer and Griffen appeared in literature in 1960 for their first textbook on reliability. Barlow and Hunter (1961) analyzed one-unit system and its reliability. In India Professor R.S. Verma and his student Garg, Mohan and Singla(1962) initiated the study regarding reliability technology in Delhi University. A one unit system with operating and failed states was considered by Hosford(1960) where failure and repair both were stationary type. Then he found the probabilities of the system at an instant of time, either the system is in failure state or repair state. A two unit system with general failure and exponential repair time distributions was considered by Mohan and Garg(1962). By using supplementary variable technique they verified their result by the result of Hosford (1960) by taking it as a special case. Some of statisticians, Linton and Saw (1974) considered (k,n) system and analyze the system's reliability. What effect standby redundancy will have on system's reliability was discussed by Kapoor and Kapoor (1976). Some considered the similar system with a device, named imperfect switch over device. Standby system review was considered by Aggarwal and Kumar (1980). Kumar et al. (1991,92) and Singh et al. (1991,92) worked and studied reliability on some complex industrial systems. Automobile systems which also have complexity were discussed by William (1959) and Dhilon et al. (1981). In the field of reliability, the earlier researchers analyzed the respective system using an analytical method named Laplace transform. The systems were also discussed by these workers which exhibit Markovian properties. Non-Markovian property ex-

hibiting systems can be converted to a system having markovian property using some technique. Some new variables known as supplementary variables were introduced. Cox(1995) analyzed the non-Markovian systems using supplementary variables.

When a system has more than one unit there are chances of complete failure of the system because of single cause. Such failures are termed as common cause failures and these are highly effective as far as reliability analysis of the system is considered. Due to single common cause, Gahloft(1975) defined cause failures in a system with multiple components or units at an instant of time. Some important factor of critical human error which causes complete failure of the system was introduced by Dhilon and Misra (1984).Pawan Gupta et al. (2005) used numerical approach to investigate the behavioral analysis of cement manufacturing plant A. He also analyze the reliability and availability using matrix calculus method of Serial processes of Plastic-Pipe manufacturing Plant in 2007. Shahkuntala et al. (2011) discussed reliability analysis of Polytube Industry using supplementary variable technique. Lata et al. (2013) discussed mathematical analysis of reliability and availability on Piston Manufacturing Plant.

In present study a method is proposed to analyze reliability of Tyre Mounting Hub Leakage in JCB Robot 135 manufactured in JCB India Pvt. Ltd. in Ballabgarh near New Delhi. A chapter wise summary of this work is presented in subsequent section.

1.2 Definitions and basic concepts

The ability of system or component to perform its required functions for a specified period of interval under stated conditions is defined as Reliability. According to Ajit Kumar Verma (2016), this definition brings into focus four key elements, namely, ability, conditions, specified period of time and required functions. These four elements are very important in determining reliability of system or component. The brief discussion of these four is as follows:

Ability: is expressed quantitatively with probability. Reliability is expressed as probability. We all have in our mind that reliability factor of one would mean that there is a guarantee that every component of the system will perform satisfactorily its function but it is not required that the system will perform its job without any failure. There can be a possibility that out of 90 trials,

3 or 5 units may fail, but as the number of trials increases, the ratio of the number of failures to the number of successes is expected to approach zero.

Conditions: Stated conditions are basically referred to environmental conditions of operation. The environmental conditions like shock, humidity, temperature, vibration and so on.

Specified period of time: It provides expected duration of operation. In the defined definitions of this chapter, this is considered to be the most important factor because it represents a measure of the period for which the performance is satisfactory. It happens that many components or systems or devices fail when operated for long periods. Reduction in strength of materials and parts is natural and as a result of which the performance level of the unit or system go down with the time. So, it is required to specify a time limit within which the performances of a unit is to be estimated whether it is satisfactory or unsatisfactory.

Required Functions: It relates to the expected performance. May be there are some examples of the system which are giving satisfactory performance even when one or two of its components are not functioning.

Failure Rate: Ratio of number of failures of the items undergoing test to the test time. Failures per unit time is defined as the failure rate. It can be like failures per day or week or month or year. Also known as Hazard rate or Instantaneous failure rate.

Repair rate: The ratio of the number of repairs of the items undergoing test to the test time is Repair rate. It can be expressed in terms of number of repairs per unit time. Like repairs per hour or day or year. It is also known as the instantaneous repair rate.

MTTF: MTTF is Mean Time To Failure. It is defined as the probable time to failure for a non-repairable system. It is an estimate of the average, or mean time until components first failure or disruption in the operation of the product, process, or procedure occurs. MTTF assumes that the product cannot resume any of its normal operations as it cannot be repaired.

$$MTTF = \int_0^{\infty} R(t)dt \quad (1.1)$$

Availability : It is the probability that a system or product is in operation at a specified time.

$$Availability = \frac{MTTF}{MTTF + MTTR} \quad (1.2)$$

System Configuration: By a system, we mean an arbitrary device which is having several units or subsystems or components assuming that their reliabilities are known. Now it is important that we know the system structures. Some of system structures have been considered as follows:

1. **Series Configuration**: A system having k-units is said to be having series configuration if the failure of an arbitrary component causes the entire system failure.

For example, the aircraft electronic system which is consists of mainly a sensor subsystem, a guidance subsystem, the fire control sub-system and computer subsystem. The aircraft electronic system can operate successfully if all the above defined sub-systems operate simultaneously.

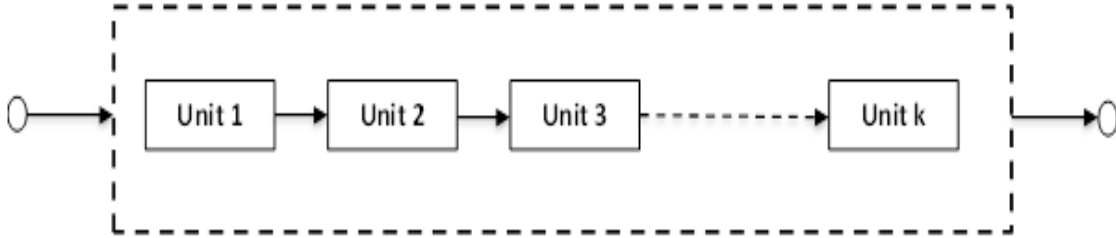

Figure 1.1: Series Configuration

Let $R_j(t)$ be the j^{th} components then the system's reliability is given by:

$$\begin{aligned} R(t) &= P[T > t] = P[\min(T_1, T_2, T_3, \dots, T_k > t)] \\ &= \prod_{j=1}^k P[T_j > t] = \prod_{j=1}^k R_j(t) \end{aligned} \quad (1.3)$$

where T_j is the life time of the j^{th} component of the system.

2. **Parallel Configuration:** In this configuration, all the components in a system are connected in parallel i.e., the failure of the system occurs only when all the components of the system fail.

for example, there is four engine aircraft which is still able to fly with only two working engines.

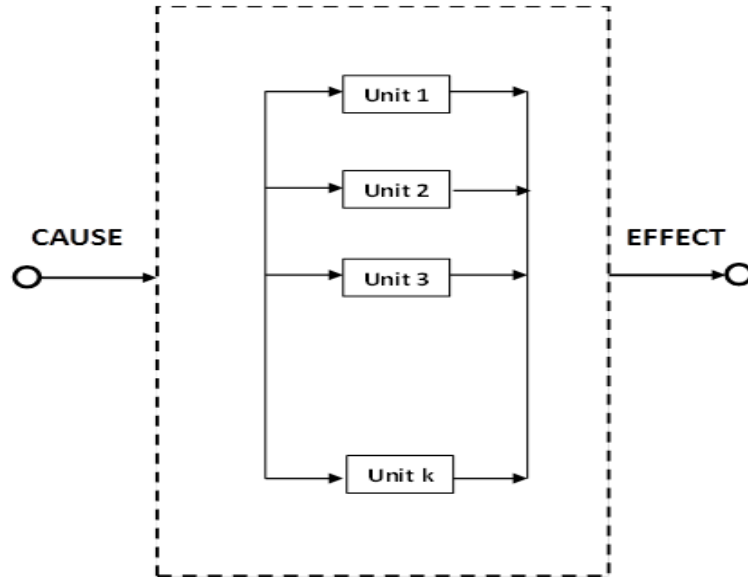

Figure 1.2: Parallel Configuration

Here, $R_j(t)$ and T_j are reliability of j^{th} component and the life time of the j^{th} component in time ' t ' resp., then the system's reliability is given by

$$\begin{aligned}
 R(t) &= P(T > t] \\
 &= P[\max(T_1, T_2, T_3, \dots, T_k) > t] \\
 &= 1 - P[T_1 \leq t, T_2 \leq t, T_3 \leq t, \dots, T_k \leq t]
 \end{aligned} \tag{1.4}$$

If the components function independently, then

$$\begin{aligned}
 R(t) &= 1 - [1 - R_1(t)][1 - R_2(t)][1 - R_3(t)] \dots [1 - R_k(t)] \\
 &= 1 - \prod_{j=1}^k [1 - R_j(t)]
 \end{aligned} \tag{1.5}$$

3. **Complex System:** These are the systems having more complex configuration than the

series and parallel systems. More techniques are required to determine the Reliability of such type of systems.

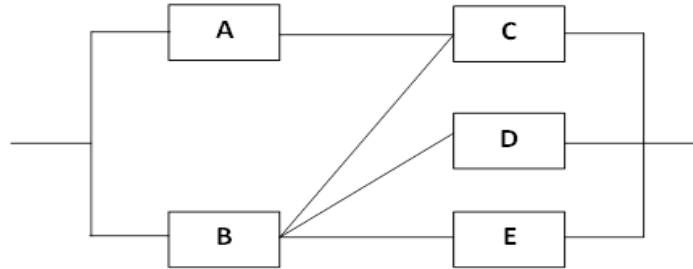

Figure 1.3: Complex System

1.3 Summary of the present work

In the recent work, we have discussed the reliability of tyre mounting hub leakage in JCB Robot 135 machine.

First chapter is introductory in nature. We have briefly given the introduction to reliability and availability of the systems. A brief survey of literature available on this topic is also discussed in this chapter.

In the second chapter, we have discussed the behaviour analysis of the tyre mounting hub leakage. We have briefly given the introduction to the industry. The methodology used for calculating reliability is discussed in this chapter. The whole process consists of five sub-systems, namely Material, Method, Machine, Men and Environment. The mathematical method of this process has been formulated with the help of Markovian method and Chapman-Kolomorgov differential equations which are solved using numerical methods. The effect of failure rates and repair rates on the reliability of the system has been studied in detail with the help of tables and graphs.

Third chapter deals with the availability method of tyre mounting hub leakage system. The

system of linear equations governing the steady state probability is solved numerically. We have analyze the effect of failure and repair rate on availability of the system with the help of tables. Industrial significance and the future scope of the present study have finally been discussed.

Chapter 2

BEHAVIOUR ANALYSIS OF TYRE MOUNTING HUB LEAKAGE IN JCB ROBOT 135 MACHINE

In this chapter, the reliability of tyre mounting hub leakage in JCB Robot 135 has been analyzed with the help of data taken from the industry JCB India Pvt. Ltd. situated in Ballabgarh near New Delhi. An introduction of industry and the problem faced by industry in manufacturing JCB robot 135 machine has been discussed in this chapter. In section 2.3, tyre mounting hub leakage system and notations has been discussed with the help of flow chart. The assumptions taken into account are discussed in section 2.4. In section 2.5, we have developed the mathematical model which determines the reliability of the tyre mounting hub leakage. In section 2.6, behaviour study of the system has been presented. Finally, in section 2.7 certain conclusions based on the present study has been discussed with the help of tables and graphs.

J.C. Bamford Excavators Limited, universally known as JCB, a British multinational corporation. JCB was founded in 1945 by Joseph Cyril Bamford. JCB India Limited is a leading manufacturer of earth moving and construction equipment in India. The company started as a joint venture in 1979 and is now a fully owned subsidiary of J.C Bamford Excavators, United Kingdom. Today, it manufactures a wide range of world-class equipment.

JCB introduced Backhole Loaders in India 35 years ago and has since expanded its product range to over 45 models in eight product categories. The Ballabgarh factory near New Delhi, which is the world's largest factory for Backhole Loaders. This is also the headquarters for JCB

India. The industry also manufactures Skid Steer Loaders, Telehandlers, Diesel Engines and Diesel Generators.

Over the years JCB has invested Rs. 2,000 crores in India and today employs 5,000 people in its Indian operations. It has a network of more than 60 dealers and 650 outlets spread throughout India. These far reaching outlets provide the vital product support to customers for their equipment.

For more than three decades, JCB has remained committed to India. It has launched new and innovative India centric products, opened new factories with customer focus and one global quality being at the core of its operations.

Many of the vehicles produced by JCB are variants of the Backhoe Loader, Compactors, Generators, Skid Steer Loaders, Telescopic Handlers, Tracked Excavators and Wheeled Loaders. From the above mentioned vehicles we have considered the Skid Steer Loader.

2.1 JCB Robot 135



In my present work, I have taken data of JCB Robot 135 machine from the industry. The JCB

Robot 135 Skid Steer Loader is a compact wonder which is designed to work efficiently. This loader has best in class fuel efficiency, lowest maintenance cost and very high productivity among Skid Steers in India. Its unmatched structure and design helps the machine to perform in tougher applications and work in confined areas.

Completely revolutionising the skid steer loader design, the JCB Robot 135 Skid Steer Loader provides the very best productivity, visibility, safety, comfort, versatility and operator access in the market. We have discussed the reliability of Tyre Mounting Hub Leakage in JCB Robot 135 machine.

2.2 Defining the problem

We all know that there is no machine or device which works without any failure. The industry faces some problems while manufacturing and testing the vehicle. The industry has categorized the list of problems in two categories: Category 1 and Category 2. In category 1, they have identified 17 problems in the machine from which they have solved 14 and in category 2, they have identified 39 problems from which 28 are solved. They captured the data related to Leakage and they found out that there are four problems which are contributing 85% in total.

From the four problems there is one problem which is contributing 47% of total. The problem is Tyre Mounting Hub Leakage where Hub is a part on which the tyre is mounted in machine. This problem is captured when the machine goes under testing. A pictorial view of the steps of testing is given in Figure 2.1:

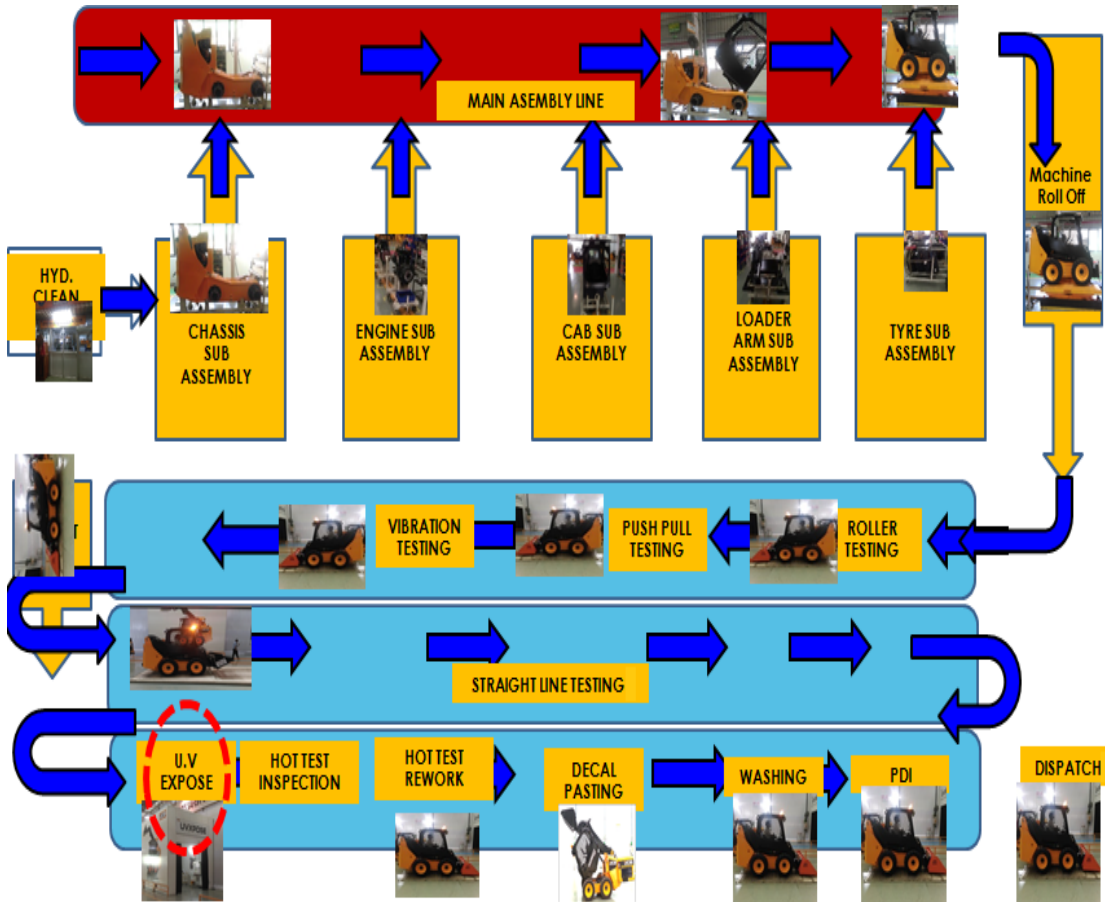

Figure 2.1: Pictorial View of steps of testing

After Tyre assembly on hub, the engineers run the machine in hot test. They found hub joint leak from chassis side. During the Shack hour testing they found oil near Tyre Mounting Hub. Due to this problem the Quality & production suffers.

Tyre Hub Leakage has five components on which it depends, namely, Material, Method, Machine, Men and Environment. In Material, we have five sub-components, namely, Sealant adhesion on paint surface, chain case flatness, hub flatness, O-ring hardness and hub groove depth. In Method, we have techniques used in manufacturing machine in tyre hub case which are Torquing sequence, sealant area defining, proper tapping and surface preparation. In Machine, we have tools which are used in the tyre hub process and those are calibrated torque meter, calibrated torque wrench and tap size. Man is basically the worker and engineer who take care

of the following: torquing, surface cleaning, tapping at 90deg. , applying sealant, sealant time adherence and the sequence to be followed from the SOP. Last is the Environment in which sealant temperature and sealant in air contact comes.

From the five components, there are two components because of which the tyre mounting hub leakage problem is occurring, these two components are Material and Method. In this thesis, we have worked on the reliability and availability of the system. We have verified that after varying Material and Method sub-system's failure and repair rate what effect they will be having on system's reliability and availability.

2.3 System and Notation

1. Sub-system *A* (Material): In Tyre mounting hub leakage, this is the sub-system which is subject to the major and minor failure. Here sealant adhesion on lead free paint surface and chain case flatness are important to take care of.
2. Sub-system *B* (Method) : The sub-system's one of the component Torquing sequence is important to be done in sequence. It is subject to major and minor failure.
3. Sub-system *C* (Machine) : The tools used such as calibrated torque meter, tap size and calibrated torque wrench for torquing comes under this sub-system. The sub-system is considered to be never failed system.
4. Sub-system *D* (Man) : This sub-system has the engineers who follows SOP manual to follow the sequence, to apply sealant, surface cleaning and torquing. It is considered as never failed sub-system.
5. Sub-system *E* (Environment) : This sub-system includes sealant temperature, sealant in air contact. The sealant in sub-system *A* is used as per the weather conditions. This sub-system is a never failed sub-system.

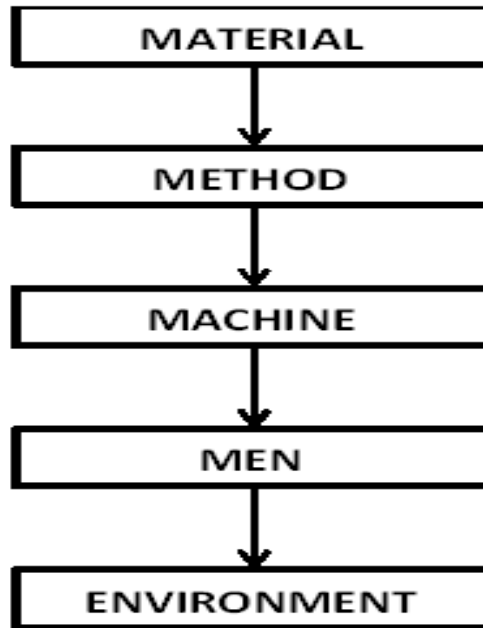

Figure 2.2: Flow Chart of Tyre Mounting Hub Leakage

NOTATIONS : The following notations for system A , B , C , D and E are used to denote good conditions of the system. \bar{A} and \bar{B} indicates that A and B are in reduced states.

α_i ($i=1$ to 4) represents constant failure rates of sub-systems a , b , \bar{A} and \bar{B} .

β_i ($i=1$ to 4) represents constant repair rates of sub-systems a , b , \bar{A} and \bar{B} .

$P_j(t)$ = Probability that system is in j^{th} state at time t , ($j=1,2,3,\dots,8$).

Small letters a , b indicate the failed states of the sub-systems A and B respectively.

2.4 Assumptions for the sub-system R1

1. Failure and Repair rates are independent with each other and their unit is per day.
2. Repair of A and B in reduced state make these sub-systems completely functional.

- 3. C, D and E sub-systems are never failed sub-systems.
- 4. A and B sub-systems fail only through reduced state.

The Transition diagram of the system using the above notations and assumptions is given in Figure 2.4

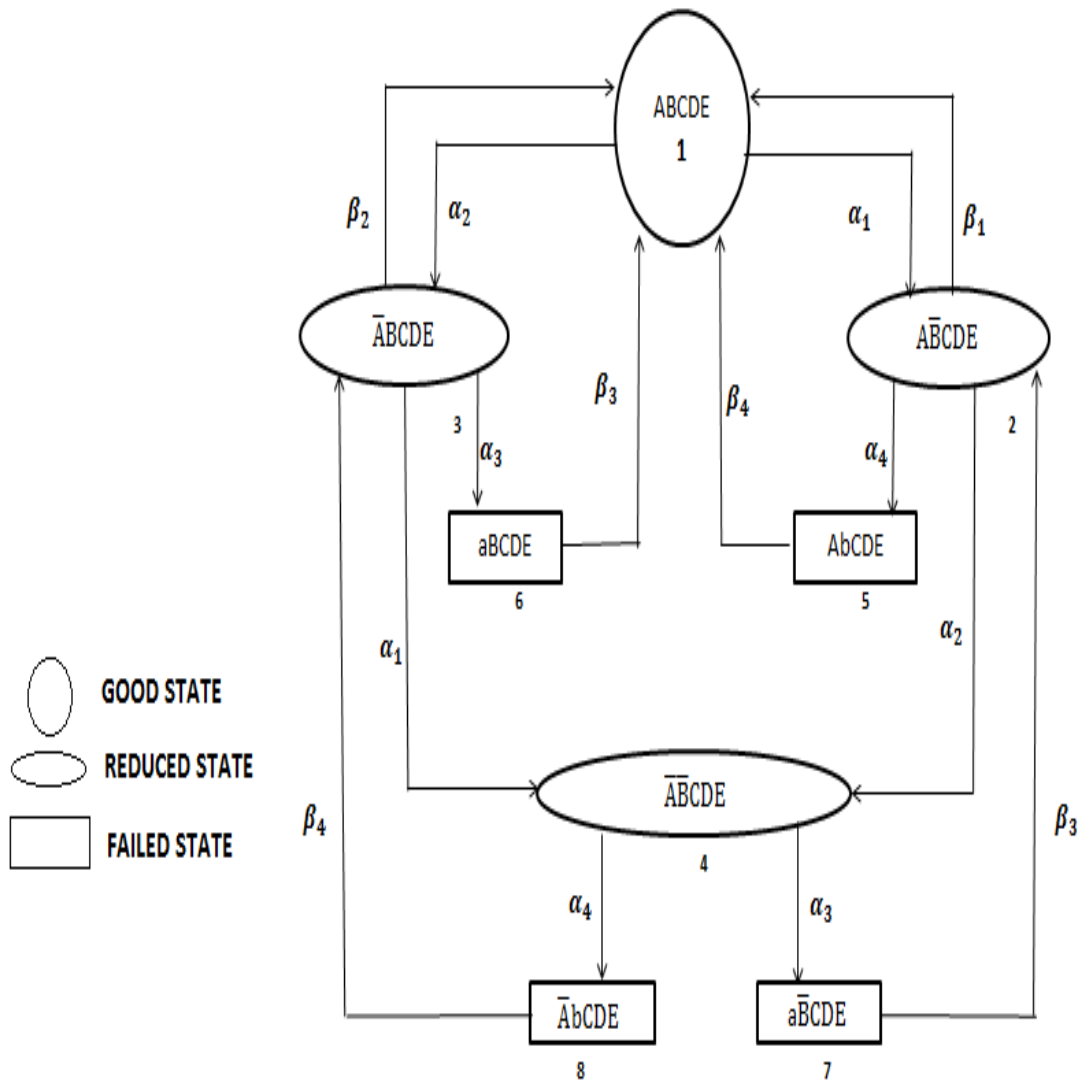

Figure 2.3: Transition Diagram for Sub-system R1

2.5 Mathematical Model of Tyre Mounting Hub Leakage

Mathematical Formulation of the sub-system R1:

The following are first order differential equations associated with the transition diagram of the system given by probability considerations in the transition state.

$$P_1'(t) + \lambda_1 P_1(t) = \beta_1 P_2(t) + \beta_2 P_3(t) + \beta_4 P_5(t) + \beta_3 P_6(t) \quad (2.1)$$

$$P_2'(t) + \lambda_2 P_2(t) = \alpha_1 P_1(t) + \beta_3 P_7(t) \quad (2.2)$$

$$P_3'(t) + \lambda_3 P_3(t) = \beta_4 P_8(t) + \alpha_2 P_1(t) \quad (2.3)$$

$$P_4'(t) + \lambda_4 P_4(t) = \alpha_2 P_2(t) + \alpha_1 P_3(t) \quad (2.4)$$

$$P_5'(t) + \beta_4 P_5(t) = \alpha_4 P_2(t) \quad (2.5)$$

$$P_6'(t) + \beta_3 P_6(t) = \alpha_3 P_3(t) \quad (2.6)$$

$$P_7'(t) + \beta_3 P_7(t) = \alpha_3 P_4(t) \quad (2.7)$$

$$P_8'(t) + \beta_4 P_8(t) = \alpha_4 P_4(t) \quad (2.8)$$

where

$$\lambda_1 = \alpha_1 + \alpha_2$$

$$\lambda_2 = \alpha_2 + \beta_1 + \alpha_4$$

$$\lambda_3 = \alpha_1 + \alpha_3 + \beta_2$$

$$\lambda_4 = \alpha_4 + \alpha_3$$

with initial conditions $P_1(0) = 1$ and 0 otherwise.

As we can see the differential equations (2.1-2.8) are very complex. Finding analytical solution of these equations is very difficult, particularly using the method called Laplace transformation. Therefore, above equations have been solved using numerical method earlier used by Pawan et al (2005,2007). The numerical integration is carried out with $t = 0.005$ considering it as one day. Thus to get the reliability upto 360 days for various combinations of the failure rates and repair rates, we have performed 72000 iterations in the Runge-Kutta Fourth Order Method. The reliability function $R(t)$ of the system is finally computed by

$$R(t) = \sum_{i=1}^4 P_i(t) \quad (2.9)$$

The reliability of the system, as defined in (2.9) has been computed for various values of repair and failure rates. The effects of failure and repair rates of the sub-system on the Reliability of the system have been computed and presented in tables 2.1(a)-2.1(d).

2.6 Behaviour Study

Behaviour Study of sub-system R1

The above defined differential equations of the system with initial conditions has been solved numerically using R.K. 4th order method. The calculations have been executed upto 360 days for various values of failure and repair rates of the sub-systems. Here we have considered the data of failure rate and repair rate as per day. The effect of number of different parameters on system R1's reliability is studied in this section. If the failure and repair rates are altered, the reliability is affected.

(i) Effect of failure rate of Material on reliability of the system: System's reliability is calculated from the following combinations of failure and repair rates. Table 2.1(a) is representing Reliability and the parameter α_3 is taken at the level of 0.00098, 0.00128, 0.00158, 0.00185, 0.00238 and other parameters are taken as: $\alpha_1=0.011666$, $\alpha_2 = 0.01166$, $\alpha_4 = 0.00238$, $\beta_1 = 0.4666$, $\beta_2 = 3.733$, $\beta_3 = 0.2666$, $\beta_4 = 0.0333$. The table 2.1(a) shows the effect of material (α_3) on the reliability of the system. The reliability decreases insignificantly with the increase in failure rate of material from 0.00098 to 0.00238 and by approx. 0.5% with the increase in time from 30 to 360 days.

Table 2.1(a): EFFECT OF FAILURE RATE OF MATERIAL (α_3) ON RELIABILITY OF THE SYSTEM

$\alpha_3 \rightarrow$ Days \downarrow	0.00098	0.00128	0.00158	0.00185	0.00238
30	0.998733	0.998722	0.998711	0.998702	0.998683
60	0.997840	0.997824	0.997808	0.997794	0.997766
90	0.997167	0.997150	0.997133	0.997119	0.997091
120	0.996610	0.996597	0.996584	0.996573	0.996553
150	0.996129	0.996123	0.996117	0.996113	0.996105
180	0.995704	0.995708	0.995712	0.995717	0.995726
210	0.995325	0.995341	0.995358	0.995373	0.995402
240	0.994987	0.9950175	0.995047	0.995073	0.995125
270	0.994684	0.994729	0.994773	0.994812	0.994886
300	0.994413	0.994474	0.994533	0.994584	0.994681
330	0.994171	0.994247	0.994321	0.994385	0.994505
360	0.993953	0.994046	0.994135	0.994211	0.994354

(ii) Effect of failure rate of Method on reliability of the system: The parameter α_4 is taken at the level of 0.00238, 0.00277, 0.00317, 0.00357, 0.00397 and other parameters are taken as: $\alpha_1=0.01166$, $\alpha_2 = 0.01166$, $\alpha_3 = 0.00238$, $\beta_1 = 0.4666$, $\beta_2 = 3.733$, $\beta_3 = 0.2666$, $\beta_4 = 0.3333$. The table 2.1(b) shows the effect of method (α_4) on the reliability of the system. The reliability decreases by approx. 0.08% with the increase in failure rate of method from 0.00238 to 0.00397 and by approx. 0.5% with the increase in time from 30 to 360 days.

Table 2.1(b): EFFECT OF FAILURE RATE OF METHOD (α_4) ON RELIABILITY OF THE SYSTEM

$\alpha_4 \longrightarrow$ Days \downarrow	0.00238	0.00277	0.00317	0.00357	0.00397
30	0.998683	0.998484	0.998281	0.998079	0.997877
60	0.997766	0.997436	0.997100	0.996765	0.996434
90	0.997091	0.996673	0.996249	0.995829	0.995415
120	0.996553	0.996071	0.995586	0.995110	0.994642
150	0.996105	0.995578	0.995049	0.994534	0.994030
180	0.995726	0.995164	0.994606	0.994063	0.993537
210	0.995402	0.994816	0.994236	0.993676	0.993136
240	0.9951252	0.994520	0.993926	0.993356	0.992808
270	0.994886	0.994269	0.993667	0.993091	0.992541
300	0.994681	0.994057	0.993449	0.992871	0.992321
330	0.994505	0.993876	0.993266	0.992689	0.992141
360	0.994354	0.993722	0.993113	0.992538	0.991994

(iii) Effect of repair rate of Material on reliability of the system: The parameter β_3 is taken at the level of 0.2666, 0.2606, 0.2546, 0.2486, 0.2426 and other parameters are taken as: $\alpha_1=0.01166$, $\alpha_2 = 0.01166$, $\alpha_3 = 0.00238$, $\alpha_4 = 0.00238$, $\beta_1 = 0.4666$, $\beta_2 = 3.733$, $\beta_4 = 0.3333$. The table 2.1(c) shows the effect of material (β_3) on the reliability of the system. The reliability of the system decreases by approx. 0.001% with the decrease in repair rate of material from 0.2666 to 0.2426 and by approx. 0.43% with the increase in time from 30 to 360 days.

Table 2.1(c): EFFECT OF REPAIR RATE OF MATERIAL (β_3) ON RELIABILITY OF THE SYSTEM

$\beta_3 \rightarrow$ Days \downarrow	0.2666	0.2606	0.2546	0.2486	0.2426
30	0.998683	0.998681	0.998679	0.998677	0.998675
60	0.997766	0.997763	0.997759	0.997755	0.997751
90	0.997091	0.997087	0.997082	0.997076	0.9970712
120	0.996553	0.996547	0.996541	0.996534	0.996527
150	0.996105	0.996098	0.996091	0.996084	0.996075
180	0.995726	0.995719	0.995710	0.995702	0.9956931
210	0.9954029	0.995394	0.995385	0.995375	0.995366
240	0.995125	0.995116	0.995106	0.995096	0.995085
270	0.9948867	0.994876	0.994866	0.994855	0.994844
300	0.9946818	0.994671	0.994660	0.994649	0.994637
330	0.994505	0.994494	0.994483	0.994472	0.994459
360	0.994354	0.994343	0.994331	0.994319	0.994306

(iv) Effect of repair rate of Method on reliability of the system: The parameter β_4 is taken at the level of 0.0333, 0.0323, 0.0313, 0.0303, 0.0293 and other parameters are taken as: $\alpha_1=0.01166$, $\alpha_2 = 0.01166$, $\alpha_3 = 0.00238$, $\alpha_4 = 0.00238$, $\beta_1 = 0.4666$, $\beta_2 = 3.733$, $\beta_3 = 0.2666$. The table 2.1(d) shows the effect of material (β_4) on the reliability of the system. The reliability of the system decreases by approx. 0.006% with the decrease in repair rate of method from 0.0333 to 0.0293 and by approx. 0.43% with the increase in time from 30 to 360 days.

Table 2.1(d): EFFECT OF REPAIR RATE OF METHOD (β_4) ON RELIABILITY OF THE SYSTEM

$\beta_4 \rightarrow$ Days \downarrow	0.0333	0.0323	0.0313	0.0303	0.0293
30	0.998683	0.99866	0.998655	0.998640	0.998626
60	0.997766	0.997727	0.997687	0.997646	0.997604
90	0.997091	0.997030	0.996966	0.996899	0.996830
120	0.996553	0.996472	0.996388	0.996300	0.996207
150	0.996105	0.996009	0.995908	0.995802	0.995690
180	0.995726	0.995617	0.995502	0.995381	0.995253
210	0.995402	0.995283	0.995156	0.995022	0.994880
240	0.995125	0.994996	0.994859	0.994715	0.994561
270	0.994886	0.994749	0.994604	0.9944511	0.994287
300	0.994681	0.994538	0.994386	0.994224	0.994052
330	0.994505	0.9943563	0.994197	0.994029	0.993850
360	0.994354	0.9941999	0.994036	0.993862	0.993676

2.7 Analysis of Results

The comparative study of the tables 2.1(a) to 2.1(d) shows that the sub-system B (Method) affects the reliability of the sub-system R1 more than the other sub-system A (Material). The sub-system Material is almost equally affects the reliability, which is clear from the above tables. The effect of failure and repair rate of sub-system B of R1 on the reliability of R1 can be verified with the help of Graphs 2.2 and 2.4. Therefore, we will recommend the management that they should pay more attention to sub-system B (Method) to increase the reliability of Tyre Mounting Hub Leakage on JCB Robot 135 Machine.

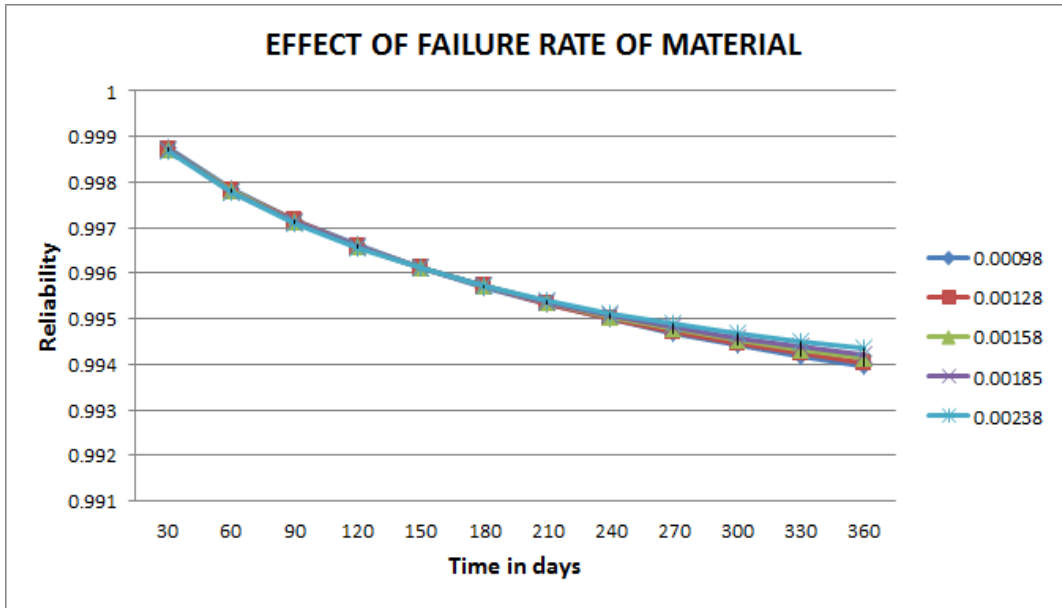

Graph 2.1

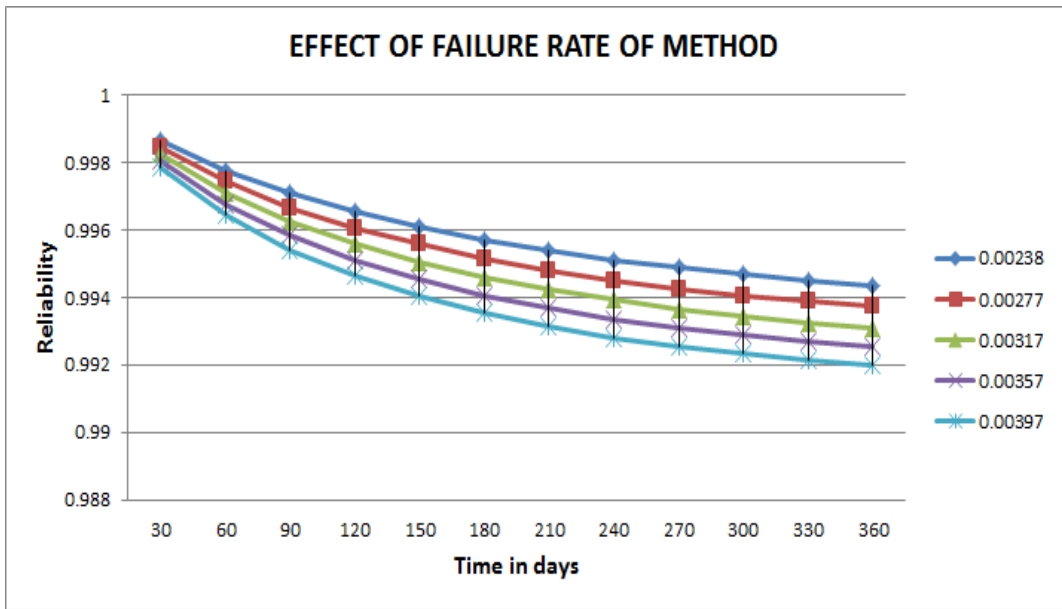

Graph 2.2

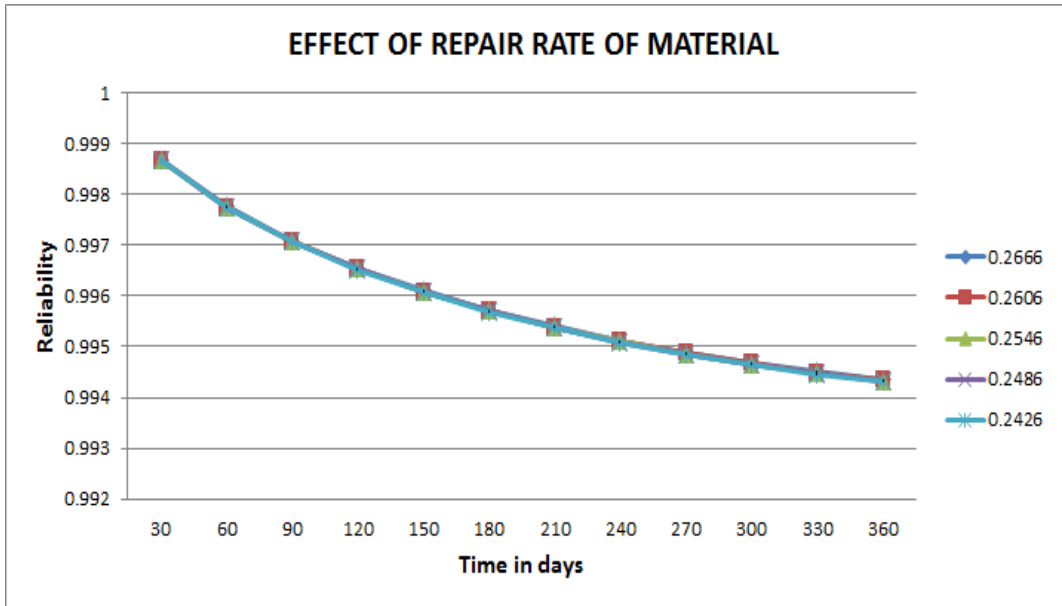

Graph 2.3

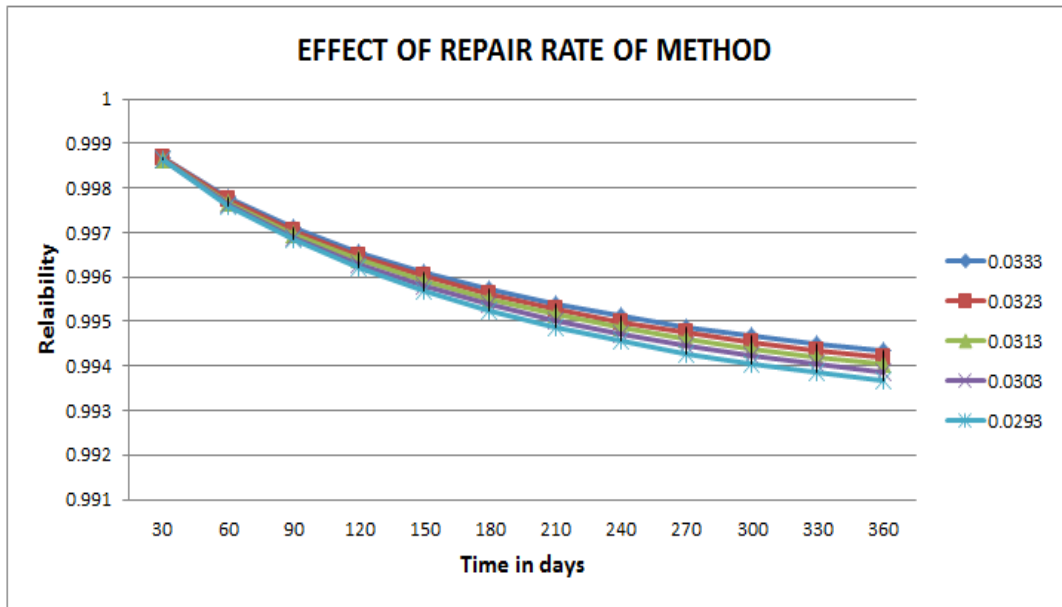

Graph 2.4

Chapter 3

AVAILABILITY MODEL OF TYRE MOUNTING HUB LEAKAGE SYSTEM

3.1 Mathematical Formulation

Management normally is interested in the long run availability of the system in the process industries. The availability of Tyre Mounting Hub Leakage in JCB 135 Robot machine has been obtained by taking different combinations of constant failure and repair rates of the sub-systems collected from the concerned industry. Till now we were dealing with the first order differential equations in the transient state associated with the transition diagram.

For availability, steady state probabilities of the system are required which are obtained by taking $\frac{d(P)}{dt} \rightarrow 0$ as $t \rightarrow \infty$. In the R1 system we have reduce the differential equations (2.1-2.8) to the following system of linear equations.

$$\lambda_1 P_1(t) = \beta_1 P_2(t) + \beta_2 P_3(t) + \beta_4 P_5(t) + \beta_3 P_6(t) \quad (3.1)$$

$$\lambda_2 P_2(t) = \alpha_1 P_1(t) + \beta_3 P_7(t) \quad (3.2)$$

$$\lambda_3 P_3(t) = \beta_4 P_8(t) + \alpha_2 P_1(t) \quad (3.3)$$

$$\lambda_4 P_4(t) = \alpha_2 P_2(t) + \alpha_1 P_3(t) \quad (3.4)$$

$$\beta_4 P_5(t) = \alpha_4 P_2(t) \quad (3.5)$$

$$\beta_3 P_6(t) = \alpha_3 P_3(t) \quad (3.6)$$

$$\beta_3 P_7(t) = \alpha_3 P_4(t) \quad (3.7)$$

$$\beta_4 P_8(t) = \alpha_4 P_4(t) \quad (3.8)$$

where

$$\lambda_1 = \alpha_1 + \alpha_2$$

$$\lambda_2 = \alpha_2 + \beta_1 + \alpha_4$$

$$\lambda_3 = \alpha_1 + \alpha_3 + \beta_2$$

$$\lambda_4 = \alpha_4 + \alpha_3$$

with initial conditions $P_1(0) = 1$ and 0 otherwise.

The system of linear equations (3.1-3.8) with the normalizing equation

$$\sum_{i=1}^8 P_i(t) = 1 \quad (3.9)$$

The Long run Availability $A(\infty)$ of the system can be computed as

$$A(\infty) = \sum_{i=1}^4 P_i(t) \quad (3.10)$$

3.2 Numerical Analysis

In order to solve the system of linear equations (3.1-3.8), we have used Gauss Elimination method. As this is a homogeneous system of linear equations and gives a trivial solution. We have replaced any one equation among (3.1-3.8) by the equation (3.9) to make it non-homogeneous. For different combinations of repair and failure rates, we have solved the system and summarized the results as follows:

The availability as defined in (3.10) is calculated for different values of the repair and failure rates. Computation has been carried by varying the failure and repair rates of Material as: $\alpha_3 = 0.00098, 0.00128, 0.00158, 0.00185, 0.00238$, $\beta_3 = 0.2426, 0.2486, 0.2546, 0.2606, 0.2666$ and

by taking other parameters as fixed: $\alpha_1 = 0.011666$, $\alpha_2 = 0.011666$, $\alpha_4 = 0.00238095$, $\beta_1 = 0.46666$, $\beta_2 = 3.73333$, $\beta_4 = 0.03333$. The computed result as shown in table 3.1(a) reveals that increase in failure rate (α_3) of material has constant long run availability and the repair rate (β_3) increases the availability approx. 0.001%.

Table 3.1(a): EFFECT OF FAILURE RATE (α_3) AND REPAIR RATE (β_3) OF THE SUB-SYSTEM MATERIAL ON AVAILABILITY OF THE SYSTEM

$\alpha_3 \rightarrow$	0.00098	0.00128	0.00158	0.00185	0.00238
$\beta_3 \downarrow$					
0.2426	0.99209	0.99245	0.99276	0.99362	0.99341
0.2486	0.99210	0.99242	0.99277	0.99364	0.99342
0.2546	0.99211	0.99246	0.99279	0.99365	0.99344
0.2606	0.99212	0.99248	0.99280	0.99367	0.99345
0.2666	0.9921	0.99249	0.99281	0.99368	0.9935

Now, computation has been carried by varying the failure and repair rates of Material as: $\alpha_4 = 0.00238, 0.00277, 0.00317, 0.00357, 0.00397$, $\beta_4 = 0.0293, 0.0303, 0.0313, 0.0323, 0.0333$ and by taking other parameters as fixed: $\alpha_1 = 0.011666$, $\alpha_2 = 0.011666$, $\alpha_3 = 0.00238095$, $\beta_1 = 0.46666$, $\beta_2 = 3.73333$, $\beta_3 = 0.26666$. The computed result as shown in table 3.1(b) reveals that increase in failure rate (α_4) of method decreases long run availability approx. 0.25% and the repair rate (β_3) increases the availability approx. 0.08%.

Table 3.1(b): EFFECT OF FAILURE RATE (α_4) AND REPAIR RATE (β_4) OF THE SUB-SYSTEM METHOD ON AVAILABILITY OF THE SYSTEM

$\alpha_4 \rightarrow$	0.00238	0.00277	0.00317	0.00257	0.00397
$\beta_4 \downarrow$					
0.0293	0.99271	0.99207	0.99134	0.99076	0.99021
0.0303	0.99293	0.99231	0.99161	0.99105	0.99052
0.0313	0.99314	0.99253	0.99186	0.99130	0.99081
0.0303	0.99333	0.99275	0.99209	0.99157	0.99107
0.0293	0.99351	0.99295	0.99231	0.99181	0.99133

3.3 Analysis of Results

The comparative study of above tables 3.1(a) and 3.1(b) reveals that the sub-system Method affects the availability of the whole system more than the other sub-system Material. The effect of failure and repair rate of Method on the availability of system has been demonstrated with the help of Table 3.1(b). Therefore, we will recommend the management that they should pay more attention to sub-system B(Method) to increase the availability of Tyre Mounting Hub Leakage on JCB Robot 135 Machine.

3.4 Concluding Observations

3.4.1 Industrial Significance of this study

Reliability, nowadays, has become an extremely important factor for every product in industries, the methodology discussed is designed for studying problems of reliability. These factors are helpful for future planning of industry, to get more profit and for manufacturing more reliable products. Our analysis depends on the actual data of failure and repair rates of the sub-systems. We conclude from the analysis of results that the results are in agreement with the actual performance of the manufacturing industry.

3.4.2 Limitations and Future scope of the present study

In the present work, we have studied and analyzed the effect of failure and repair rates of sub-system A and B on the sub-system R1. The limitation of the present study is that we haven't analyzed the effect of failure and repair rates of other sub-systems on the sub-system R1 be-

cause of insufficient data we got from the industry.

We have used numerical methods to study the effect of failure and repair rate on reliability and availability of one of the component of JCB Robot 135 machine. In future, we can study the effect of failure and repair rate on reliability and availability of each components to increase the reliability of the machine.

REFERENCES

- [1] Aggarwal M., Kumar A. "A review of standby system" IEEE Trans. Reliab. (1980): 290-294.
- [2] Andrews J.D., Moss T.R., Reliability and Risk Assessment, Wiley-Blackwell,(2002).
- [3] Barlow R.E., Hunter L.C. "Reliability analysis of a one-unit system" 9(2) (1961):200-208.
- [4] Davis D. "An analysis of some failure data." Journal of the American Statistical Association 47(258) (1952): 113-150.
- [5] Dhillon B.S., Reliability, Quality, and Safety for Engineers, CRC Press,(2005)
- [6] Dhillon B.S., Singh C. "Engineering reliability: new techniques and applications", New York: Wiley (1981)
- [7] Dhillon B.S., Misra R.B. "Reliability evaluation of systems with critical human error" 24(4) (1984):743-759.
- [8] Elsayed E.A., Reliability Engineering, John Wiley and Sons, vol.88 (2012)
- [9] Gupta P., Lal A.K., Sharma R.K., Singh J. "Numerical analysis of reliability and availability of the serial processes in butter-oil processing plant", International Journal of Quality Reliability Management, 22(3) (2005): 303-316.
- [10] Gupta P., Lal A.K., Sharma R.K., Singh J. "Analysis of reliability and availability of serial processes of plastic-pipe manufacturing plant: a case study", International Journal of Quality Reliability Management, 24(4) (2007): 404-419.
- [11] Hosford, John E. "Measures of dependability." Operations Research 8(1) (1960): 53-64.

- [12] Kapur P.K., Kapoor K.R. "Effect of standby redundancy on system reliability" 25(2) (1976): 120-121.
- [13] Kaur M., Lal A.K., Bhatia S.S., Reddy A.S. "Reliability, Availability, and Maintainability (RAM) Analysis of an Industrial Process" (Doctoral dissertation), 2014.
- [14] Kaur M., Lal A.K., Bhatia S.S., Reddy A.S. "Numerical solution of stochastic partial differential difference equation arising in reliability engineering. Applied Mathematics and computation" 219(14) (2013): 7645-7652.
- [15] Kumar D., Singh J., Pandey P.C. "Behavioural analysis of a paper production system with different repair policies" 31(1) (1991): 47-51
- [16] Lal A.K., Kaur M., Lata S. "Behavioral study of piston manufacturing plant through stochastic models", Journal of Industrial Engineering International 9(1) (2013): 24.
- [17] Lata s., Reliability Analysis of Piston Manufacturing Plant, M.Sc. Dissertation, Thapar University, Patiala,(2009)
- [18] Linton, Darrell G., and John G. Saw. "Reliability analysis of the k-out-of-n: F system" 23(2) (1974): 97-103.
- [19] Mohan C., and Garg R.C. "Dependability of a system with general failure time and exponential repair time distribution", (1962): 243-246.
- [20] Nakagawa T., Stochastic Processes with Applications to Reliability Theory, Springer Science and print media,2011
- [21] Shakuntla, Reliability Modeling and analysis of some process industrial systems, Ph.D. Thesis, Thapar University, Patiala,(2012)
- [22] Shakuntla, Lal A.K., Bhatia S.S., Singh J. "Reliability analysis of polytube industry using supplementary variable technique" 2818(8) (2011): 3981-3992.
- [23] Shakuntla, Lal A.k., Bhatia S.S. "Comparative study of the subsystems subjected to independent and simultaneous failures", 4(58) (2011):63-71
- [24] Sood H. "Reliability and Availability analysis of Timber Processing Plant", M.Sc. Dissertation, Thapar University, Patiala,(2012)

- [25] Verma A.K., Srividya A., Rao K.D., Reliability and Safety Engineering, London: Springer, 43(2010)
- [26] William, H. C. "Automotive Transmission and Power Trans." (1959)