

“Performance Analysis of Super DWDM with OADM and Modulation Formats”

Thesis submitted in the partial fulfilment of requirement

for the award of degree of

Master of Engineering

In

Electronics and Communication Engineering

Submitted by:

Vishant Narang

801061030

Under the guidance of:

Dr. R. S. Kaler

Sr. Professor (ECED) &

DEAN (Resource Planning and Generation)



**ELECTRONICS AND COMMUNICATION ENGINEERING
DEPARTMENT**

THAPAR UNIVERSITY

(Established under the section 3 of UGC Act, 1956)

PATIALA – 147004 (PUNJAB)

JULY 2012

CERTIFICATE

I, Vishant, hereby certify that the work which is being presented in this thesis entitled, **“Performance Analysis of Super DWDM with OADM and Modulation Formats”**, by me in partial fulfillment of the requirements for the award of degree of Master of Engineering in Electronics and Communication Engineering from Thapar University (Deemed University), Patiala, is an authentic record of my own work carried out under the supervision of **Dr. R. S. Kaler**.

The matter presented in this thesis has not been submitted in any other University / Institute for the award of any other degree.

Date: 13th July 2012

Vishant Narang

Roll No. 801061030

It is certified that the above statement made by the student is correct to the best of my knowledge and belief.

Date: 13th July 2012

Dr. R. S. Kaler
Sr. Professor (ECED) &
Dean of Resource
Planning and Generation

Countersigned by:

(Dr. Rajesh Khanna)

Professor and Head ECED

Thapar University, Patiala

Date:

(Dr. S.K. Mohapatra)

Dean of Academic Affairs

Thapar University, Patiala

Date:

ACKNOWLEDGEMENT

A thesis cannot be completed without the help of many people who contribute directly or indirectly through their constructive criticism in the evolution and presentation of this work. A special debt of gratitude is owed to my thesis supervisor, Dr. R. S. Kaler (Sr. Professor ECED, DEAN Resource Planning and Generation) for his gracious efforts and keen pursuit which has remained as a valuable asset for the successful fulfillment of my thesis. His dynamism and diligent enthusiasm has been highly instrumental in keeping my spirits high. His flawless and forthright suggestions blended with an innate intelligent application have crowned my task with success.

I would like to offer my sincere thanks to Dr. R. K. Khanna (Head, ECED) for his motivation and inspiration that triggered me for my thesis work. I am also thankful to all faculty, teaching and non-teaching, of Electronics and Communication Engineering Department (ECED), and staff of central library, TU, Patiala, for their assistance.

I am also thankful to the authors whose works I have consulted and quoted in this work. Last, but not the least, very special thanks to my parents and my friends for their constant encouragement and best wishes. Their patience and understanding without which this study would not have been in this present form, is greatly appreciated.

Vishant Narang

ABSTRACT

Wavelength division multiplexing is an optical technology that employs transmission of multiple data signals over a single optical fiber. Nonlinearities of optical fiber lead to distortion and attenuation of optical signals, resulting in degradation of WDM systems. Common nonlinear optical effect in fibers is due to refractive index. In the first case we demonstrate Quality factor performance resulting from XPM effect for NRZ and RZ soliton transmitting formats at 10 Gb/s with channel spacing of 12.5 GHz. XPM is limiting factor when gain of EDFA is small. RZ soliton is better than NRZ at small distance of 200 km and at large distance of 3200 km. Core effective area is key parameter to get higher Quality factor. In second case, ring optical network has been demonstrated and analyzed at each node with bit rate of 2.5 Gbps, 5Gbps and 10 Gbps for different modulation formats like NRZ rectangular, NRZ raised cosine, RZ soliton, RZ super gaussian, RZ raised cosine and RZ rectangular. The distance between the nodes is set to 120km (SMF+DCF). Semiconductor optical amplifier after each node enhances the power level. The effect of insertion losses for a wide range of 40 dB to 100 dB is analyzed and it seen that RZ-soliton is performing better among all modulation driving schemes. It is seen that by using RZ soliton format system can exist up to 95 dB of insertion loss. The effect of OADM bandwidth is also analyzed and it is seen that after 10 GHz bandwidth there is huge rise in the system performances for NRZ rectangular and RZ soliton In the last we investigate the performance of 256 channel WDM system with channel spacing of 25 GHz and 50 GHz with bit rate of 2.5 Gbps at different distances. We analyze the result at the receiving frequencies like 193.025 GHz, 193.225 GHz, 193.35GHz, 193GHz, 195.2GHz, 195.075GHz, 195.175GHz, 195.425 GHz. We see that performance of the system is better for 50 GHz spacing.

TABLE OF CONTENTS

CERTIFICATE	i
ACKNOWLEDGEMENT	ii
ABSTRACT	iii
TABLE OF CONTENTS	iv-vi
LIST OF FIGURES	vii-ix
LIST OF TABLES	x
CHAPTER 1: INTRODUCTION	1-14
1.1 Introduction to Fiber Optical Commun	1
1.2 Multiplexing	2
1.2.1 Types of multiplexing techniques	2
1.2.1.1 Coarse Wavelength Division Multiplexing (CWDM)	3
1.2.1.2 Dense Wavelength Division Multiplexing (DWDM)	4
1.3 Origins of Nonlinearities	5
1.3.1 Optical Kerr Effect	5
1.3.2 Self Phase Modulation (SPM)	5
1.3.3 Cross Phase Modulation (XPM)	5
1.3.4 Four Wave Mixing (FWM)	6
1.4 Ring Network	6
1.5 OADM	8
1.6 Modulation Formats	11
1.6.1 NRZ Rectangular	12
1.6.2 NRZ Raised Cosine	12

1.6.3 RZ Rectangular	12
1.6.4 RZ Raised Cosine	12
1.6.5 RZ Supergaussian	13
1.6.6 RZ Soliton	13
1.7 OptSim	13
1.7.1 System Requirements for OptSim	14
CHAPTER 2: LITERATURE REVIEW	15-24
2.1 Literature Riview	15
2.2 Motivation	23
2.3 Thesis Objectives	23
2.4 Organization of Thesis	24
CHAPTER 3: Analysis of NRZ and RZ soliton Transmission in DWDM Systems	25-35
3.1 Introduction	25
3.2 Simulation Setup	27
3.3 Results and Discussions	28
3.4 Conclusion	35
CHAPTER 4 Performance Analysis of Ring Optical Network with OADM for different Transmitting Formats	36-48
4.1 Introduction	36
4.2 Theory	37
4.3 Simulation Setup	38

4.4 Results and Discussions	40
4.4 Conclusion	48
CHAPER 5: To investigate the performance of 256 channel WDM system with channel spacing of 25 GHz and 50 GHz	49-57
5.1 Introduction	49
5.2 Theory	51
5.2 Simulation Setup	51
5.3 Results and Discussions	53
5.4 Conclusion	57
CHAPTER 6: CONCLUSION AND FUTURE SCOPE	59
REFERENCES	

LIST OF FIGURES

Figure 1.1	Time division multiplexing	2
Figure 1.2	Wavelength division multiplexing	3
Figure 1.3	Ring Network	7
Figure 1.4	Architecture of a WDM ring network node	8
Figure 1.5	Internal structure of OADM	9
Figure 1.6	Broadcast Selective	10
Figure 1.7	Wavelength Selective	11
Figure 3.1	Schematic diagram of 32 channel WDM system	27
Figure 3.2	Simulation setup of 32 channel WDM system for 200 km	27
Figure 3.3	Simulation setup of 32 channel WDM system for 3200 km	28
Figure 3.4	XPM effect on NRZ and RZ soliton transmission formats for different dispersion values.	29
Figure 3.5	Eye diagram of NRZ format after 200 km	29
Figure 3.6	Eye diagram of RZ soliton format after 200 km	30
Figure 3.7	Eye diagram of NRZ format after 3200 km	30
Figure 3.8	Eye diagram of RZ soliton after 3200 km.	30
Figure 3.9	XPM effect on NRZ format for different effective area and dispersion	31
Figure 3.10	XPM effect on RZ soliton format for different effective area and dispersion	32

Figure 4.1	Block diagram of simulation setup	38
Figure 4.2	Simulation Setup	40
Figure 4.3	Bandwidth v/s Q-factor	41
Figure 4.4	Bandwidth v/s BER	42
Figure 4.5	Bandwidth v/s Q-factor	42
Figure 4.6	Bandwidth v/s BER	43
Figure 4.7	Bandwidth v/s Q-factor	43
Figure 4.8	Bandwidth v/s BER	44
Figure 4.9	Insertion loss v/s Q-factor	45
Figure 4.10	Insertion loss v/s BER	45
Figure 4.11	Insertion loss v/s Q-factor	46
Figure 4.12	Insertion loss v/s BER	46
Figure 4.13	Insertion loss v/s Q-factor	47
Figure 4.14	Insertion loss v/s BER	47
Figure 4.15	Q-factor v/s bit rate for RZ soliton	48
Figure 5.1	Attenuation v/s Wavelength	50
Figure 5.2	Internal structure of Tx-1	52
Figure 5.3	Simulation setup for 256 Channel.	52
Figure 5.4	Fiber with dispersion removing techniques	53
Figure 5.5	Internal Structure of Receiver	53

Figure 5.6	Eye diagrams for 25 GHz spacing	54
Figure 5.7	Q-factor v/s Distance	55
Figure 5.8	Eye diagrams for 50 GHz spacing	56
Figure 5.9	Input Power spectrum	57
Figure 5.10	Input Power spectrum	57

LIST OF TABLES

Table 3.1	Q-Factor v/s Dispersion	33
Table 3.2	Q-Factor v/s Distance	33
Table 3.3	Q-Factor v/s core effective area for different dispersions	34
Table 3.4	Q-Factor v/s core effective area for different dispersions	34

CHAPTER 1

INTRODUCTION

1.1 Introduction to Fiber Optical Communication:

Since the mid 90's, optical fibers have been used for point to point communication at a very high speed. Fiber-optic communication is a method of transmitting information from one place to another by sending light through an optical fiber. Fiber-optic communication systems have revolutionized the telecommunications industry and played a major role in the advent of the information age. Often the optical fiber offers much higher speed than the speed of electronic signal processing at both ends of the fiber. Because of its advantages over electrical transmission, the use of optical fiber has largely replaced copper wire communications in the developed world.

The main benefits of fiber are its exceptionally low loss, allowing long distances between amplifiers or repeaters and its inherently high data-carrying capacity, such that thousands of electrical links would be required to replace a single high bandwidth fiber. Another benefit of fiber is that even when run alongside each other for long distances, fiber cables experience effectively no crosstalk, in contrast to some types of electrical transmission lines. The main advantages of the optical fiber communications are the high speed, large capacity and high reliability by the use of the broadband of the optical fiber. The huge bandwidth of optical fiber communication system can be utilized to its maximum by using multiple access techniques. So to be able to take the full advantage of the speed in optical fibers one of the basics concepts in fiber optic communication is the idea of allowing several users to transmit data simultaneously over the communication channel by simultaneously allocating the available bandwidth to each user. This is called multiple accesses. There are two types of multiple access techniques: Asynchronous and Synchronous. Asynchronous multiple access methods, where network access is random and collisions occur are well suited to LAN's with low traffic demand [1]. However, these asynchronous access methods suffer from cumulative delay as the traffic intensity increases. On the other hand, synchronous accessing methods, where transmissions are perfectly scheduled provide more successful transmissions than asynchronous methods [2].

1.2 Multiplexing

Since the first wires were laid for telegraphs in the 1800's, the drive has been to increase the amount of information that can be sent in a given interval. In the early years of telegraphs, telephones, and other telecommunications, the simple and obvious solution was to add more lines of communication. The increased cost of wire-laying and maintenance quickly built up, however, and a new answer to the problem had to be invented. The answer was multiplexing, in which more than one signal is sent over the same line [3].

1.2.1 Types of multiplexing techniques

The commonly used multiplexing techniques are TDM and WDM.

(a) TDM: Time division multiplexing (TDM) is the least efficient form of multiplexing. In TDM, multiple signals are transferred, but each one is sent in parts, as seen in the figure below:

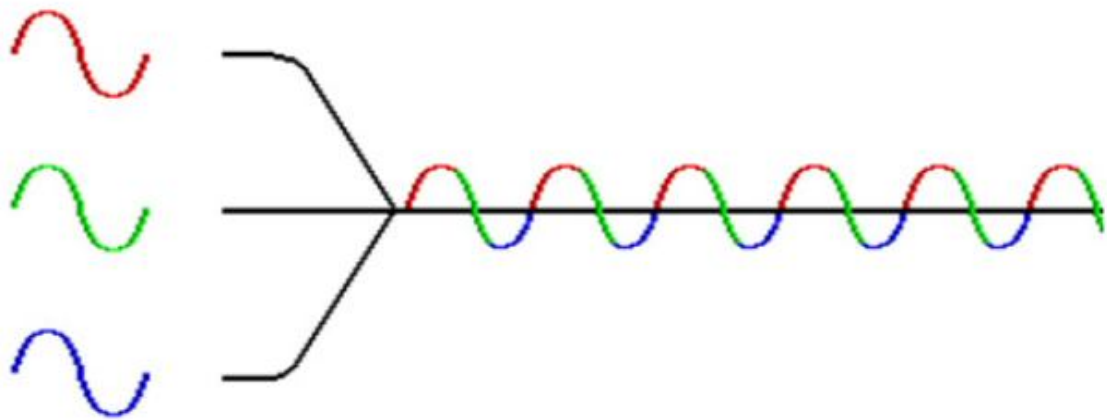

Figure 1.1: Time division multiplexing [3]

It is clear in the figure that two thirds of each signal is lost due to the division of time that gives TDM its name. This form of multiplexing is uneconomical for digital information transfers, as much of the signal from each source is lost. If the number of users on a line is high, or if there are about the same number of users on a line at all times, a new multiplexing scheme should be used [3].

(b) WDM: Since wavelength and frequency are closely related to each other, this form of multiplexing is often called frequency division multiplexing (FDM). Each WDM fiber has a certain bandwidth—the range of frequencies it can carry [2]. One advantage of WDM is that every user can transmit information at the highest rate possible all the time. WDM does not change transfer rates in proportion to the number of users on the line. Another large benefit to WDM is that it increases the amount of information that can be transferred without significant loss of signal integrity. In any two fibers of the same quality, one signal will be lost just as fast as ten or more, so there is nothing to be lost and much to be gained from WDM. Even with the new solution to the bandwidth bottleneck, the ground gained by WDM was lost quickly, and another step forward had to be made [3].

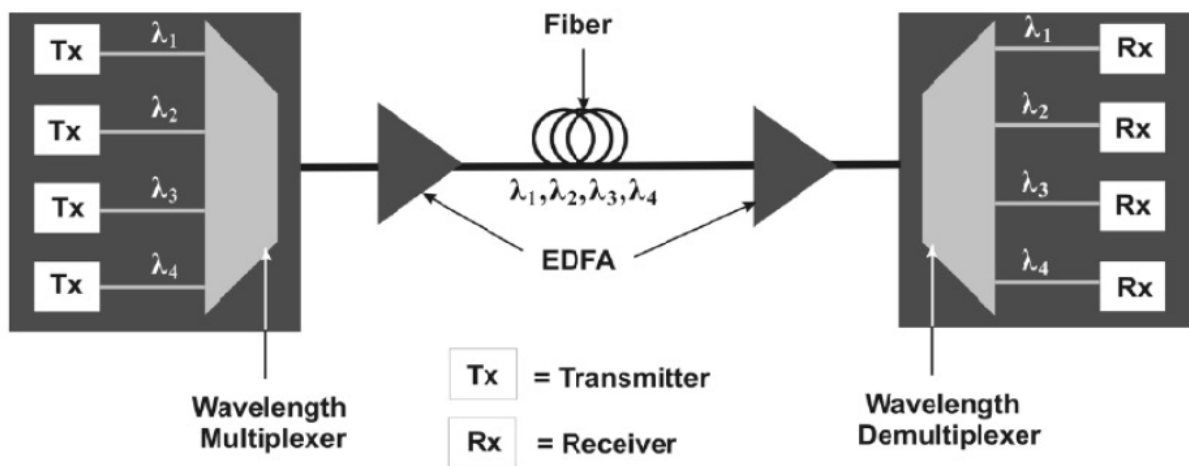

Figure 1.2: Wavelength division multiplexing [3]

Two different version of WDM can be defined below:

- i. Coarse Wavelength Division Multiplexing(CWDM)
- ii. Dense Wavelength Division Multiplexing(DWDM)

1.2.1.1 Coarse Wavelength Division Multiplexing (CWDM)

Coarse wavelength division multiplexing (CWDM) is a method of combining multiple signals on laser beams at various wavelengths for transmission along fiber optic cables, such that the number of channels is fewer than in dense wavelength division multiplexing (DWDM) but more than in standard wavelength division multiplexing (WDM) [4].

CWDM systems have channels at wavelengths spaced 20 nanometers (nm) apart, compared with 0.4 nm spacing for DWDM. This allows the use of low-cost, lasers for CWDM. In a typical CWDM system, laser emissions occur on eight channels at eight defined wavelengths: 1610 nm, 1590 nm, 1570 nm, 1550 nm, 1530 nm, 1510 nm, 1490 nm, and 1470 nm. But up to 18 different channels are allowed, with wavelengths ranging down to 1270 nm. The energy from the lasers in a CWDM system is spread out over a larger range of wavelengths than is the energy from the lasers in a DWDM system. The tolerance (extent of wavelength imprecision or variability) in a CWDM laser is up to ± 3 nm, whereas in a DWDM laser the tolerance is much tighter [4]. Because of the use of lasers with lower precision, a CWDM system is less expensive and consumes less power than a DWDM system. However, the maximum realizable distance between nodes is smaller with CWDM.

1.2.1.2 Dense Wavelength Division Multiplexing (DWDM):

Dense wavelength division multiplexing, or DWDM for short, refers originally to optical signals multiplexed within the 1550 nm band so as to leverage the capabilities (and cost) of erbium doped fiber amplifiers which are effective for wavelengths between approximately 1525-1565 nm (C band), or 1570-1610 nm (L band). EDFAs were originally developed to replace SONET optical-electrical-optical regenerators, which they have made practically obsolete. EDFAs can amplify any optical signal in their operating range, regardless of the modulated bit rate. In terms of multi-wavelength signals, so long as the EDFA has enough pump energy available to it, it can amplify as many optical signals as can be multiplexed into its amplification band. EDFAs therefore allow a single-channel optical link to be upgraded in bit rate by replacing only equipment at the ends of the link, while retaining the existing EDFA or series of EDFAs through a long haul route [4]. Furthermore, single-wavelength links using EDFAs can similarly be upgraded to WDM links at reasonable cost. The EDFAs cost is thus leveraged across as many channels as can be multiplexed into the 1550 nm band. We will discuss about the ring network topology. A ring network is network in which no.of nodes connected in a ring. But no of nonlinearities arise in the channel. These nonlinearities are described below.

1.3 Origins of Nonlinearities

A number of nonlinearities arise in the optical fibers which are the causes of the various unwanted effects in the optical fiber.

1.3.1 Optical Kerr Effect

The optical Kerr effect or AC Kerr effect is the case in which the electric field is due to the light itself. This causes a variation in index of refraction which is proportional to the local irradiance of the light. This refractive index variation is responsible for the nonlinear optical effects of self-focusing and self-phase modulation. This effect only becomes significant with very intense beams such as those from lasers. In fact, phase modulation due to intensity dependent refractive index induces various nonlinear effects, namely, self-phase modulation (SPM), cross-phase modulation (CPM), and four-wave mixing (FWM) [5].

1.3.2 Self Phase Modulation (SPM)

Phase modulation of an optical signal by itself is known as self-phase modulation (SPM). SPM is primarily due to the self-modulation of the pulses. Generally, SPM occurs in single-wavelength systems. At high bit rates however, SPM tends to cancel dispersion. However, consideration must be given to receiver saturation and to nonlinear effects such as SPM, which occurs with high signal levels. SPM results in phase shift and a nonlinear pulse spread. As the pulses spread, they tend to overlap and are no longer distinguishable by the receiver. The acceptable norm in system design to counter the SPM effect is to take into account a power penalty that can be assumed equal to the negative effect posed by XPM [6]. By the SPM-impact new spectral components are generated in the optical signal spectrum resulting in a spectral broadening.

1.3.3 Cross Phase Modulation (XPM)

Cross-phase modulation (XPM) is a nonlinear effect that limits system performance in wavelength Division Multiplexed (WDM) systems. XPM is the phase modulation of a signal caused by an adjacent signal within the same fiber. XPM is related to the combination (dispersion/effective area). XPM results from the different carrier frequencies of independent

channels, including the associated phase shifts on one another. The induced phase shift is due to the walkover effect, whereby two pulses at different bit rates or with different group velocities walk across each other. As a result, the slower pulse sees the walkover and induces a phase shift. The total phase shift depends on the net power of all the channels and on the bit output of the channels. Maximum phase shift is produced when bits belonging to high-powered adjacent channels walk across each other [5].

1.3.4 Four Wave Mixing (FWM)

FWM can be compared to the inter modulation distortion in standard electrical systems. When three wavelengths (λ_1 , λ_2 , and λ_3) interact in a nonlinear medium, they give rise to a fourth wavelength (λ_4), which is formed by the scattering of the three incident photons, producing the fourth photon. This effect is known as four-wave mixing (FWM) and is a fiber-optic characteristic that affects WDM systems [6]. The effects of FWM are pronounced with decreased channel spacing of wavelengths and at high signal power levels. High chromatic dispersion also increases FWM effects. FWM also causes inter channel cross-talk effects for equally spaced WDM channels

1.4 Ring Network:

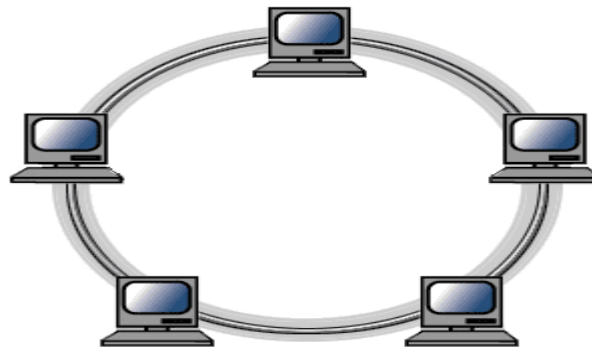

Figure 1.3: Ring Network [7]

SONET is the most widely used optical network infrastructure today. In a SONET ring network, WDM is mainly used as a point-to-point transmission technology. Each wavelength in such a SONET/WDM network is operated at OC-N line rate, e.g., $N = 48$. The SONET system's hierarchical TDM schemes allow a high-speed OC-N channel to carry multiple OC-M channels. The ratio of N and the smallest value of M carried by the network is called

"grooming ratio". Electronic add-drop multiplexers (ADMs) are used to add/drop traffic at intermediate nodes to/from the high-speed channels [7]. With the progress of WDM, over a hundred wavelengths can now be supported simultaneously by a single fiber. It is, therefore, too costly to put the same amount of ADMs (each of which has a significant cost) at every network node since a lot of traffic is only bypassing an intermediate node [8]. With the emerging optical components such as optical add-drop multiplexers (OADM) (also referred to as wavelength add-drop multiplexers (WADM)), it is possible for a node to bypass most of the wavelength channels optically and only drop the wavelengths carrying the traffic destined to the node. Figure 1.4 shows the architecture of a typical node in a SONET/WDM ring network. For some wavelengths, since there is no need to add or drop any of its timeslots, they can be optically bypassed at the node. For other wavelengths (λ_2 and λ_3) where at least one timeslot needs to be added or dropped, an electronic ADM is used. Compared with the wavelength channel resource, ADMs form the dominant cost in a SONET/WDM ring network. Hence, carefully arranging these optical bypasses can reduce a large amount of the network cost. It is clear that using OADMs can decrease the number of SONET ADMs needed in the network and eventually bring down the network cost.

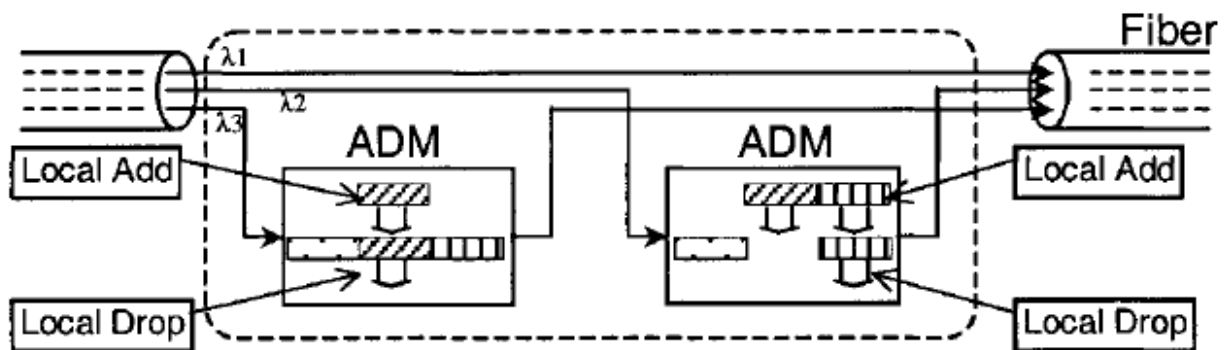

Figure 1.4: Architecture of a WDM ring network node [8]

Metropolitan networks have been attracting much attention as they impose a bandwidth bottleneck between the local access networks and the backbone. The deployed circuit-switched SONET rings are relatively inefficient for dynamic traffic, and although several approaches to adapt circuit-switched techniques to data traffic are in the standardization stage, many efforts are oriented to the design of packet-switched techniques combined with WDM to increase the bandwidth.

There is a limit on the number of nodes in the network. It is difficult to increase the number of nodes M , in the ring since the network needs M wavelength channels and each node needs $M - 1$ receiver to accept dropped optical signals from the ring. The RingO (ring optical network) metro network is a unidirectional fiber ring network that comprises N nodes, where N equals the number of wavelengths each node is equipped with an array of fixed-tuned transmitters and one fixed-tuned receiver operating on a given wavelength that identifies the node. Node j drops wavelength j from the ring. All wavelengths are slotted with the slot length equal to the transmission time of a fixed size data packet plus guard time [9]. Each node checks the state of the wavelength occupation on a slot by slot basis, avoiding collisions by means of a multichannel generalization of the empty slot approach (in the empty slot approach one bit at the beginning of each slot indicates the state of the corresponding slot.. This access mechanism gives priority to in transit traffic by allowing a monitoring node to use only empty slots. Because a ring topology provides only one pathway between any two nodes, ring networks may be disrupted by the failure of a single link. A node failure or cable break might isolate every node attached to the ring. FDDI networks overcome this vulnerability by sending data on a clockwise and a counterclockwise ring in the event of a break; data are wrapped back onto the complementary ring before it reaches the end of the cable, maintaining a path to every node along the resulting C-Ring. An optical ring network using photonic packet switching devices is designed here. The optical ring network consists of optical switching nodes linked by fiber optic cables to form a closed optical path. In ring network at each node we used Optical add drop multiplexer for add/drop of channels. Description of OADM is given below.

1.5 OADM

An optical add-drop multiplexer (OADM) is a device used in Wavelength division multiplexing systems for multiplexing and routing different channels of light into or out of a single mode fiber (SMF). This is a type of optical node, which is generally used for the construction of optical telecommunication networks. "Add" and "drop" here refer to the capability of the device to add one or more new wavelength channels to an existing multi-wavelength WDM signal, and/or to drop (remove) one or more channels, passing those signals to another network path. An OADM may be considered to be a specific type of optical cross connects.

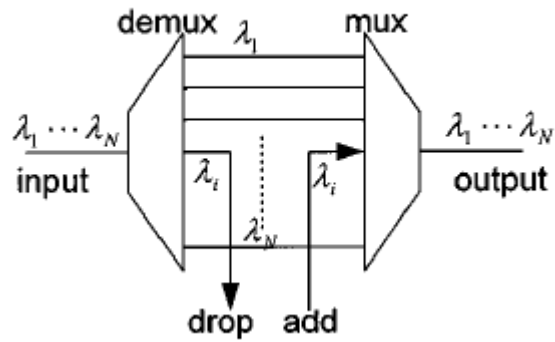

Figure 1.5: Internal structure of OADM [10]

A traditional OADM consists of three stages: an optical demultiplexer, an optical multiplexer, and between them a method of reconfiguring the paths between the optical demultiplexer, the optical multiplexer and a set of ports for adding and dropping signals. The optical demultiplexer separates wavelengths in an input fiber onto ports. The reconfiguration can be achieved by a fiber patch panel or by optical switches which direct the wavelengths to the optical multiplexer or to drop ports. The optical multiplexer multiplexes the wavelength channels that are to continue on from demultiplexer ports with those from the add ports, onto a single output fiber [10]. All the light paths that directly pass an OADM are termed cut-through light paths, while those that are added or dropped at the OADM node are termed added/dropped light paths. An OADM with remotely reconfigurable optical switches in the middle stage is called a reconfigurable OADM (ROADM). Ones without this feature are known as fixed OADMs. While the term OADM applies to both types, it is often used interchangeably with ROADM. A reconfigurable optical add-drop multiplexer (ROADM) is a form of optical add-drop multiplexer that adds the ability to remotely switch traffic from a WDM system at the wavelength layer. This is achieved through the use of a Wavelength selective switching module. This allows individual or multiple wavelengths carrying data channels to be added and/or dropped from a transport fiber without the need to convert the signals on all of the WDM channels to electronic signals and back again to optical signals.

The main advantages of the ROADM are:

- The planning of entire bandwidth assignment need not be carried out during initial deployment of a system. The configuration can be done as and when required without affecting traffic already passing the ROADM.
- ROADM allows for remote configuration and reconfiguration.
- In ROADM, as it is not clear beforehand where a signal can be potentially routed, there is a necessity of power balancing of these signals. ROADMs allow for automatic power balancing.

The switching or reconfiguration functions of a ROADM can be achieved using a variety of switching technologies including MEMS, Liquid crystal, thermo optic and beam-steering switches in planar waveguide circuits, and tunable optical filter technology [6].

Reconfigurable OADMs can be divided into two main generations. The first is mainly applied in linear network configurations and does not support optical path protection, while the second is applied in ring configurations and provides optical layer protection. The two most common examples of fully-reconfigurable OADMs, i.e., wavelength selective (WS) and broadcast selective (BS) architectures, are illustrated in Figure. 1.6 and Figure 1.7

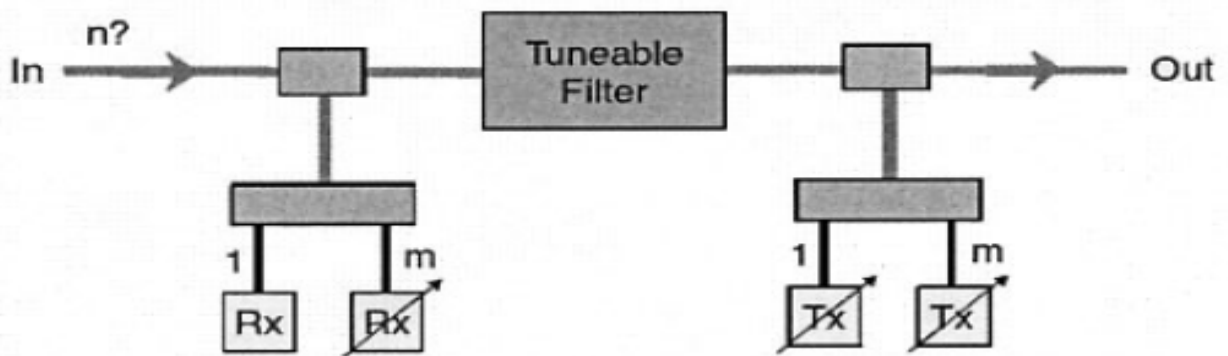

Figure 1.6: Broadcast Selective [6]

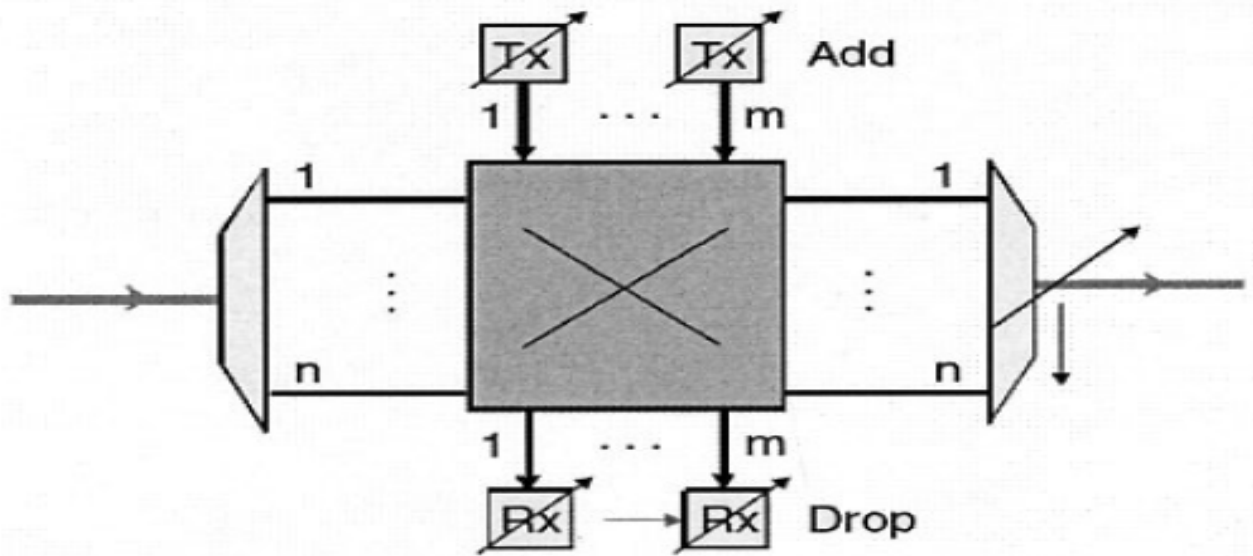

Figure 1.7: Wavelength Selective [6]

The WS architecture utilizes wavelength de-multiplexing/multiplexing and a switch fabric interconnecting express and add/drop ports, while the BS is based on passive splitters/couplers and tunable filters. The overall loss introduced by the through path of the BS solution is noticeably lower than the loss of the WS approach, significantly improving the optical signal-to-noise ratio of the node and therefore its concatenation performance in a practical transmission link or ring. In addition, the BS design offers superior filter concatenation performance, advanced features such as drop and continue, and good scalability in terms of add/drop percentage

1.6 Modulation Formats

This component simulates an electrical driver. It converts the logical input signal, a binary sequence of zeros and ones into an electrical signal. Several mapping laws are available, ranging from simple ones, such as NRZ and RZ rectangular shaped, to NRZ raised cosine, RZ raised cosine, RZ supergaussian and RZ soliton shaped pulses [12].

1.6.1 NRZ Rectangular

This component simulates the NRZ rectangular driver. It has an electrical output signal which can assume one of the two electrical levels depending on the transmitted bit. When a "1" is fed into the driver, the output signal is at the Low Level during the entire bit time. When a "0" is fed into the driver, the output signal is at the High Level during the entire bit time. Switching between the two levels may be instantaneous if the field Time Slope is set to zero, or not otherwise, with the desired time slope.

1.6.2 NRZ Raised Cosine

This component simulates the NRZ raised cosine driver. As for the NRZ rectangular driver the output signal has two levels: one for ones and the other for zeros. Switching between the two levels is not instantaneous: it follows a raised cosine shape with a given roll-off. The difference between this driver and the RZ raised cosine pulse driver lies in the fact that in the RZ modulation the signal is forced to return to the "0" level at the end of the each bit, also if there are two consecutive bits at the "1" level. The raised cosine waveform, when the driver is connected to a linear optical modulator, can shape either the optical amplitude or the optical power.

1.6.3 RZ Rectangular

This component simulates the RZ rectangular driver. It has an output signal that can assume two electrical levels. When a "1" is transmitted, the output signal is at the High Level for a time equal to the product of the duty cycle by the bit time. Then it goes down to the Low Level for the remaining time. When a "0" is transmitted, the output is constant at the low level for the entire bit time. Switching between the two levels is instantaneous with resulting square edges

1.6.4 RZ Raised Cosine

This component simulates the RZ raised cosine driver. As for the RZ rectangular driver, it has an output signal with levels and the typical return to zero of the waveform when one is transmitted after a time dependent from the duty cycle parameter. The difference lies in the

fact that switching between the two levels is not instantaneous: it follows a raised cosine shape with a given roll-off. The raised cosine waveform, when the driver is connected to a linear optical modulator, can shape either the optical amplitude or the optical power.

1.6.5 RZ Supergaussian

This component simulates the RZ supergaussian driver. When "1" is transmitted it generates a pulse with supergaussian shape. When a "0" is transmitted, the output signal is set to the Low Level for the entire bit time.

1.6.6 RZ Soliton

This component simulates the RZ soliton driver. When a "1" is transmitted it generates a pulse with soliton shape. When a "0" is transmitted the output signal is set to the Low Level for the entire bit time. Considering a time origin in the middle of the bit time (where the pulse peak is centered), when a "1" is transmitted.

1.7 OptSim

The core version of OptSim was first developed in 1983 by the Optical Communication Group of Politecnico di Torino [10]. The optical simulation software was originally known as TopSim, a transmission system simulation package, which was developed for mobile and satellite communication. TopSim was further improved with the addition of a library for optical systems and after continuous refinement efforts by the simulation specialists of Politecnico di Torino, the simulation software was later known as OptSim. OptSim is an advanced vectorial fiber simulator tool that takes into account all important phenomena including fiber loss, chromatic dispersion, birefringence, polarization mode dispersion (PMD) and Kerr non-linearity and amplified spontaneous emission accumulation. OptSim is one of the two high-end commercial system simulators that are capable of calculating more than 15,000 km of non-linear fiber with high precision in a reasonable time. The fiber is simulated by solving the nonlinear Schrodinger equation using a modified version of the standard Split-Step Fourier (SSF) method, which solves the problems related to the cyclical numerical convolution effects intrinsic to the standard SSF method by implementing a true

linear numerical convolution by means of component processing techniques (overlap-and-add algorithm) [11]. This method has allowed extremely long fiber links to be simulated on a large window (thousand of bits at standard bit rates) with excellent accuracy. OptSim is actually the fastest simulator because all the simulation components are based on a time domain computation [10]. With OptSim, it is possible to model very closely a “real” ultra-long haul system and achieve realistic results. In addition, continuous refinement of the design parameters can be performed to achieve optimal results, which is difficult to perform in the hardware implementation environment because it can be costly, time consuming and relatively inflexible.

1.7.1 System Requirements for OptSim:

The Windows versions require for OptSim Windows 2000/XP. OptSim is not guaranteed to work under Windows 95/98/NT. OptSim will also run under Linux and various UNIX using X Windows or XFree86 and Motif. Hardware requirements areas follow [12]:

- Pentium II 400 MHz
- Minimum of 64 Mbytes of RAM for data processing. 128 Mbytes of RAM for faster processing time.
- 100 Mbytes of free space for complete OptSim installation.
- A PostScript compatible printer to print the schematics or graphs created with OptSim.
- A Color graphic display with resolution of 1024x768 pixels or higher.

CHAPTER 2

LITERATURE REVIEW

2.1 Literature Review

Charles A. Bracckett [13] reported very broad bandwidth of low-loss optical transmission in a single-mode fiber and the recent improvements in single-frequency tunable lasers have stimulated significant advances in dense wavelength division multiplexed optical networks. This technology, including wavelength-sensitive optical switching and routing elements and passive optical elements, has made it possible to consider the use of wavelength as another dimension, in addition to time and space, in network and switch design. The independence of optical signals at different wavelengths makes this a natural choice for multiple-access networks, for applications which benefit from shared transmission media, and for networks in which very large throughputs are required. In this paper they reviewed recent progress on multi wavelength networks, some of the limitations which affect the performance of such networks, and presented examples of several network and switch proposals based on these ideas.

S. W. Bang et al. [14] demonstrated the Q-factor performance of CPM effects and the FWM power for 32 channels NRZ and optical soliton transmission systems. When increased gain values for the EDFAs were used overall, the Q-factor was improved and the generated FWM power was increased in both the NRZ and optical soliton systems. The Q-factor performance associated with the CPM effect can be improved by using an LPF in both transmission systems. The simulation results indicated that the transmission format most resilient to the fiber nonlinearity was the NRZ format at a fiber length of 200 km. However, the optical soliton format has better performance than the NRZ format for fiber lengths over 1,000 km. Since an optical filter cannot efficiently block the newly generated FWM power introduced along the fiber, the FWM power cannot be suppressed by inserting an optical filter between a preamplifier and an optical communications receiver.

D. G. Daut [15] presented that CPM and FWM are significant nonlinear optical effects in DWDM systems. CPM leads to spectral broadening which may cause severe pulse distortion while FWM is a nonlinear interaction that can occur between several channels of different wavelengths. FWM may result in significant crosstalk among the channels in DWDM systems. Understanding fiber nonlinearities is crucial in order to optimize system performance. The effects of CPM and FWM in conjunction with various signaling formats in 16 channel systems were evaluated. FWM power within a fiber can be suppressed either by increasing dispersion values or by applying an appropriate filter. From simulation results they determined that a DPSK signal is less affected by the generated FWM power than the other signaling formats. For fibers having large chromatic dispersion, the DPSK signaling format was recognized as a reliable transmission scheme for alleviating the FWM effect.

N. Kikuchi et al. [17] analyzed the effect of cross-phase modulation (XPM) on wavelength division multiplexing (WDM) transmissions by experiments and numerical simulations, and provided the XPM limitation in a normalized and closed form formula. They also investigated the effect of XPM on dispersion compensated transmissions. It was shown that the location of dispersion compensators and the amount of Compensation should be determined by considering the XPM effect. They also showed that the XPM can be enhanced by the dispersion compensation and affect the optimum scheme and the amount of dispersion compensation.

Nizar Bouabdallah et al. [18] discussed about the packet-based optical access ring in metropolitan networks and showed how the proposed solution alleviates the performance degradation and the resource sub utilization while achieving fairness among bus nodes. In such a network fairness issues are likely to arise between upstream and downstream nodes competing to access a common data channel. This paper reported a new protocol called TCARD (Traffic Control Architecture using Remote Descriptors), based on a preventive reservation scheme, to alleviate the fairness problems. This paper also provided the analysis of a shared bus network's behavior with asynchronous transmission. They analyzed the system performance in terms of access delay required by each node to inject a packet into the shared medium. The analysis results show that fairness issues are likely to arise between

upstream and downstream nodes. They observed that sharing the available bandwidth fairly and arbitrarily between nodes does not resolve the fairness problem.

Tim Gyselings [19] presented the results of a crosstalk analysis of four optical wavelength division multiplexed (WDM) cross-connect (OXC) topologies. An optimal set of parameters was determined to reduce the total crosstalk. The scalability of the topologies was presented in terms of wavelengths and input fibers. The total crosstalk in function of the number of cascaded OXC's was compared for the four topologies. From the comparison between the different OXC's he conclude that the performance is limited by the filters. Both switch matrixes fulfilled the demand. Wavelength converters improved the system and made the filter requirements less strict. A high input power of the gates resulted in an extra penalty. Optimal results were obtained if filters were used in front of and behind the switch and if wavelength converters are applied. A big difference between coherent crosstalk and non coherent crosstalk has been observed as was expected. He observed that to reduce the coherent crosstalk, phase scramblers could be used. A calculation in case of coherent crosstalk gives an upper boundary on the expected crosstalk, a calculation of the incoherent case results in a lower boundary. If the lower boundary does not meet the requirements better components are necessary.

G. R. Hill et al. [20] presented an approach to the realization of a future broad-band flexible transport network employing an optical network layer. The design methodology for a network demonstrator was presented and a description of the subsystem and component technology developments described. This paper has presented an approach to the realization of a future broadband flexible transport network employing an optical network layer. An important output of the transmission studies has been to gain an appreciation of the factors such as crosstalk and noise build up that will ultimately set a limit to the dimensions of network realizations. These parameters were major design issues for multi-wavelength operation and they will ultimately limit the size of all-optical networks.

Vinod Kumar et al. [6] investigated the effect of inter channel crosstalk at ADM of a ring network at sweeping bandwidth of filters. At the bit rate of 10 Gbps, ADMs at each node was modeled by using WDM add and WDM drop components. The distance between nodes was taken 12.5 and 25 km and an ideal amplifier was inserted just before one of the node to

compensate for the total fiber loss in the ring. Dispersion and nonlinear effects of fibers were disabled to observe the crosstalk effect of ADM at sweeping bandwidth from 10 to 40GHz of fourth-order Bessel filters. The performance of the ring network varied with each sweep iteration, i.e.as the bandwidth of the WDM add and drop multiplexer was increased from 10 to 40 GHz in steps ,the Q factor of the system, the eye opening increased while the minimum BER was further reduced. The crosstalk on the other hand increased with increase in bit rate (speed), the performance of the ring optical network deteriorated. With 10 Gbps the network was more immune to cross talk than 20 or 40 Gbps. Also with increase in length of the optical fiber connected between the nodes, crosstalk and the dispersion effects became more prominent. For a 12.5km fiber length system the eye opening was much wider as compared to that in the 25km fiber length network

Alan E. Willner et al. [23] analyzed the transmission of many wavelength division-multiplexed (WDM) channels through a cascade of Erbium-doped fiber amplifiers (EDFA) in both long-distance links and ring-based networks. For a mega meter long-distance system, optimal operating conditions were found for achieving a high signal-to-noise ratio (SNR) per channel with as small an SNR differential as possible between 20 WDM channels spaced 0.5 nm apart. This paper reported that the link loss was the most critical parameter for narrowing the SNR differential between the 20 channels, and that a 25-dB small signal gain for each amplifier provides the highest overall SNR for the 20 channels transmitted across 4500 km. Additionally, through the incorporation of optical filters in a cascade of EDFA's, they determined the optimal conditions for passively equalizing many WDM channels while maintaining a high SNR for all channels. It was found that if a notch filter, having a 3-dB bandwidth of 2 nm and a center wavelength of 1560 nm, is placed after every group of 20 EDFA's, then an equalized SNR performance for potential mega meter transmission is realized. They also analyzed the critical parameters in an optically amplified WDM ring network which represented an infinite cascade of amplifiers in a closed loop. They found that a ring can accommodate 25 nodes when incorporating an EDFA and a channel-dropping filter in each node, a significant advance over non-amplified rings. They compared several node configurations, and found that the sequence of an EDFA followed by an optical tap and then a channel dropping filter provides the best performance for a wide range in system

variables including input signal power, inter-node link loss and its variability, power-tapping ratio, and small-signal gain. The relative insensitivity to the variability in link loss allows for the realization of limited modular expansion of the network. They analyzed the transmission of many wavelength division- multiplexed (WDM) channels through a cascade of erbium-doped fiber amplifiers (EDFA) in both long-distance links and ring-based networks, with the EDFA non-uniform in a closed loop. A ring can accommodate 25 nodes when incorporating an EDFA and a channel-dropping filter in each node, a significant advance over non-amplified rings. They compared several node configurations, and determined that the sequence of an EDFA followed by an optical tap and then a channel dropping filter provides the best performance for a wide range in system variables including input signal power, inter-node link loss and its variability, power-tapping ratio, and small-signal gain.

Rajneesh Randhawa et al. [24] presented the Ring O (ring optical network) comprising of various nodes and the signal was analyzed as it passed through each node in the network. It had been shown that there is no appreciable signal degradation in the ring network. It was seen that the signal keeps on improving as it passes through the successive nodes. Also when the whole ring structure was iterated with the help of spans, then improvement in the signal was observed. It was also observed that there is no appreciable signal degradation till the length of the fiber is increased up to 250 km. The effect of increasing the input power was also studied further, and it was seen that it can support more number of users by increasing the signal input power. The optical spectrum of the signal was seen at every node, to have the assessment of the add and drop frequencies in the ring. Ring networks can be used to provide a cost effective and an easily implementable way of achieving WDM networks. The coverage of metro area network is possible as ring topology is the main backbone among metropolitan cities. Here in this paper, the analysis of the ring optical network was done by taking four nodes. The signal was analyzed as it passes through each node in the ring optical network. It can be concluded from eye diagrams and jitter values taken at every node that there is no appreciable signal degradation in the network. It was seen that there is an increase in the quality factor i.e. signal keeps on improving as it passes through the successive nodes. This is one of the main advantages of RingO networks. As signal goes from node 1 to node 2 its quality factor value changes from 6.02 to 30.02. When the whole ring structure is iterated

with the help of spans, then improvement in the signal value was seen, as it passes through the various spans. Analysis of the Q factor was done taking different lengths of the fiber. It is seen that there is no appreciable signal degradation till the length of the fiber is increased up to 250 km. But after that a decrease in the quality factor can be seen.

Raza U-Mustafa et al. [25] presented the heuristics for grooming of non-uniform general traffic demands onto a given set of wavelengths available on a unidirectional or bidirectional ring. The objective was to minimize the number of higher layer equipment, like SONET Add/Drop Multiplexers (ADMs), or MPLS routers. Moreover, in the case of bidirectional rings they proposed an approach to route the traffic that reduces the total number of the required wavelengths and ADMs. In this paper, they presented the grooming of the non-uniform traffic on unidirectional and bidirectional rings. They also mapped the unidirectional rings onto a linear topology, and then develop a two-step approach to solve the grooming problem, while minimizing the number of the wavelengths and the ADMs, for the mapped topologies.

Girish V. Chowdhary et al. [26] presented the problem of survivable multicast traffic grooming in WDM bidirectional ring networks. The rapid growth of multicast applications such as video conferencing, distance learning, and online auction, has initiated the need for cost effective solutions to realize multicasting in WDM optical networks. In order to realize multicast traffic grooming in bidirectional ring networks, they proposed a node architecture based on Bidirectional Add Drop Multiplexers (BADM) to support bidirectional add/drop functionality along with traffic duplication at each node. They also proposed two traffic grooming algorithms, namely Survivable Grooming with Maximum Overlap of Sessions (SGMOS) and Survivable Grooming with Rerouting of Sessions (SGRS). Extensive simulation studies reveal that the proposed algorithms consume minimum resources measured in terms of BADM grooming ports, backup cost, and wavelengths. In this paper, they dealt with the problem of realizing survivable multicast traffic grooming in the case of WDM bidirectional ring networks. They proposed a novel solution which, under link failures, makes use of the bidirectional transmission capability of the fibers. They also proposed two algorithms, namely SGMOS and SGRS, to groom multicast sessions with an

objective to efficiently handle available bandwidth, reduce network resources and protect multicast sessions from single link failures. The algorithms proposed in this work for the survivable multicast traffic grooming problem make the assumption that the multicast traffic demands are static.

Ken-ichi Kitayama et al. [28] studied the optical filtering technique for dense wavelength division multiplexing (DWDM) channel allocation of millimeter-wave fiber-radio signals in the optical double-sideband (DSB) format. First, they investigated both theoretically and experimentally the dispersion effect of fiber Bragg grating (FBG) used as the filter on DWDM millimeter-wave optical signal transmissions. This result suggested that the dispersion effect had to be considered in the DWDM channel allocation for millimeter-wave fiber-radio access systems. Next, they proposed a DWDM allocation for millimeter-wave fiber-radio systems, which adopted the optical single-sideband (SSB) filtering technique at the receiver side by using a square response of FBG filter. It could realized the minimum WDM channel interval for optical DSB signals, while it enables the optical frequency interleave between the neighboring channels without any serious signal degradation due to the interchannel interference.

Hung Nguyen Tan et al. [29] proposed and demonstrated a reconfigurable all-optical format conversion from optical time-division multiplexing (OTDM) to wavelength division multiplexing (WDM) providing full flexibility in terms of channel spacing and wavelength allocation. The system consists of a Raman amplification-based multi wavelength pulse compressor and a parametric sampling gate. Four conventionally generated WDM 10 GHz pulse trains are compressed at the same time to around 2.5 ps and, then, used for multi wavelength sampling of a 40 Gb/s 3.49 ps OTDM signal. Simultaneous extraction of all four 10 Gb/s tributaries to WDM channels in WDM grid with tunable channel spacing is demonstrated.

Alberto Aloisio et al. [30] proposed Dense wavelength division multiplexing (DWDM) is an optical technology that allows transmitting across a fiber many wavelengths, which can be added and dropped by means of passive optical components. They presented and discussed

the performance of a complex DWDM network data transmission system that found an application in the NEMO underwater neutrino telescope. The tests cover the qualification of a complete multipoint DWDM network consisting of transponders, fibers, passive optical filters, and an optical amplifier. The behavior of the network is evaluated in the final arrangement by means of bit error ratio (BER) and optical signal-to-noise ratio measurements at 800 Mb/s rate. In order to test the network, a board, developed for the NEMO experiment, had been used. A custom DWDM module, capable of data rates up to 1.4 Gb/s and specifically designed for real-time data acquisition systems, could be hosted by the board.

Jianqiang Li et al. [31] proposed a novel low-complexity coherent receiver solution to improve spectral efficiency in wavelength-division multiplexing (WDM) systems. It is based on the receiver-side partial-response equalization and maximum-likelihood sequence detection (MLSD) in pre filtered WDM systems. The partial-response equalization shapes the channel into an intermediate state with a known partial response which is finally recovered by MLSD without the need of channel estimation. In this scheme, the severe inter symbol interference induced by the pre filtering can be shared between the partial-response equalization and MLSD. Therefore, a tradeoff can be made between complexity and performance.

Anamika et al. [32] presented Closed form formulae to study crosstalk degradation due to cross-phase modulation (XPM) induced crosstalk in periodically amplified and dispersion compensated fiber links. The formulae were used to evaluate the crosstalk performance of different modulation formats especially differential phase-shift keying (DPSK) and ON-OFF keying (OOK) which were widely used in optical communication. Crosstalk sensitivity for different data rates and pulse shapes prevalent in optical data transmission was also evaluated. The study shows that minimum XPM induced crosstalk could be achieved for 40 Gb/s RZ-DPSK signal with 33.3% duty cycle in WDM system

S. Susskind et al. [33] analyzed the transmission limits of a 40 channels DWDM system at 10 Gb/s, without using optical amplification in any part of the system. The channels were distributed between the wavelengths of 1532.7 nm (channel 1) and 1563.9 nm (channel 40).

The strategies used to increase system performance and allow for higher reaching of channels transmitted were the insertion of dispersion compensating fiber (DCF) in the link and low input power in the fiber to reduce the nonlinear effects. Using 6 km of DCF with dispersion of 250 ps/nm.km was possible to achieve the transmission distance of 116 km.

Er. Kawal Preet Singh et al. [36] had analyzed different WDM systems. The WDM system has been affected by dispersion and non-linear effects. They had also analyzed the use of PIN and APD photo detectors. They had designed three WDM system and observed their response using different dispersion values.

2.2 Motivation

According to the literature survey, it has been observed that maximum work has been done in the field by using less no. of channels and for less no. of nodes. The investigation of insertion losses and bit error rate of Optical add drop multiplexer on bit error rate, eye opening and Q-factor has rarely been done. The bit error rate decreases with increasing number of channels/users. Most arguments advocating Cross phase modulation for wavelength conversion in the research literature are qualitative and vague. Various approaches have been suggested for decreasing the fiber nonlinearity named as cross phase modulation. According to ITU-T standards, Cross phase modulation effect has been evaluated above channel spacing of 25 GHz but no evaluation has been done for channel spacing below 25 GHz, yet. In this thesis, comparison of cross phase modulation is done for ultra low values of spacing. As the channel spacing increases, the cross phase modulation effect decreases. The XPM effect on bit error rate, Q-factor, output spectrums and eye opening for different channel spacing; different number of channels and varying each transmitting component in the circuit has not been studied yet.

2.3 Thesis Objectives

In this thesis the research is carried out keeping in view the following objectives:

1. Analysis of NRZ and RZ Soliton transmission in DWDM systems.
2. Performance Analysis of Ring Optical Network with OADM for different Modulation Formats.

3. To investigate the performance of 256 channel WDM system with channel spacing of 25 GHz and 50 GHz.

2.4 Organization of Thesis

This thesis is composed of six chapters and structure of thesis is as follows:

Chapter 1 presents the brief overview WDM network, Ring network with OADM and various modulation formats.

Chapter 2 provides a literature review related to the WDM network and Ring network in order to increase the transmission distance and number of channels and users.

Chapter 3 presents Analysis of NRZ and RZ Soliton transmission in DWDM systems for a distance of 200 km and 3200km.

Chapter 4 includes Performance Analysis of Ring Optical Network with OADM for different Transmitting Formats and results are taken for various bandwidth and insertion losses.

Chapter 5 is based on the investigation of performance of 256 channel DWDM system with channel spacing of 25 GHz and 50 GHz.

Chapter 6 concludes the work carried out in this thesis with the future prospective of DWDM network and Ring network.

Analysis of NRZ and RZ Soliton transmission in DWDM systems

In this chapter we reveal the Quality factor performance resulting from XPM effect for NRZ and RZ soliton transmitting formats at 10 Gb/s with channel spacing of 12.5 GHz and 10 GHz. It is seen that for gain of 10 dB, Quality factor is very low for all dispersion values. RZ soliton is better than NRZ at distance of 200 km and at large distance of 3200 km. It is seen that the performance of the system is affected by core effective area of the fiber. As we increase the core effective area from $10 \mu m^2$ towards $100 \mu m^2$ we get the better Quality factor for both NRZ rectangular and RZ soliton.

3.1 Introduction

Dense wavelength division multiplexing is an optical technology that employs transmission of multiple data signals over a single optical fiber. Nonlinearities of optical fiber lead to distortion and attenuation of optical signals, resulting in degradation of DWDM systems. Common nonlinear optical effect in fibers is due to refractive index. Nonlinearities due to refractive index are known as Kerr nonlinearities [1]. The Kerr nonlinearities results in Self phase modulation, four wave mixing and cross phase modulation.

When optical signals propagate through optical fiber both dispersive and nonlinear optical effects influence their shape and spectrum. Non linear optical effects are more serve for long distance transmission due to nonlinear interaction. Non linear interaction depends on transmission distance and effective core area of optical fiber. Most of the nonlinear effects are results from nonlinear refraction. The refractive index of many materials can be described as

$$\eta = \eta_l + \eta_{nl} I \quad (1)$$

Where η_l and η_{nl} are linear and nonlinear refractive indices, respectively and I is the optical intensity of the field. The numerical value of η_{nl} varies in small range $2.2-3.4 \times 10^{-20}$

m^2/W . Broadening of optical signal while transmitting through optical fiber is known as dispersion. Effect of fiber dispersion is given by Taylor series:

$$\beta(\omega)=\beta_o+\beta_1(\omega - \omega_o)+\frac{1}{2}\beta_2(\omega - \omega_o)^2+\dots\dots\dots (2)$$

Here the first and second term cause phase shift and group delay, respectively. Dispersion of group velocity is represented by parameter β_2 and it is responsible for pulse broadening during propagation inside fiber. The spreading of pulse due to group velocity is known as chromatic dispersion. The dispersion parameter D is commonly given in terms of β_1, β_2 according to[3].

$$D=\frac{d\beta_1}{d\lambda} = -\frac{2\pi c}{\lambda^2} \beta_2 (3)$$

D is chromatic dispersion and expressed in units of Ps/(km-nm). XPM is nonlinear optical effect occurs when effective refractive index governing the phase of one optical signal depends on the intensity of co propagating wave. XPM causes spectral broadening of waves during propagation through fibers, owing to presence of other waves. The motive of this paper is to Q-factor performance of XPM for NRZ and RZ soliton transmission formats in 32 channel DWDM systems. S.W.Bang et al. [14] presented 32 channel DWDM system with XPM and FWM effect at 200km and 3200 km on NRZ and RZ signal formats with channel spacing of 125 GHz. and showed the quality factor at 3200 km that is 17dB & 17.7 dB for NRZ and RZ soliton respectively. D.G.Daut et al. [15] presented 16 channel DWDM systems with XPM and FWM effect for NRZ and RZ soliton formats and showed Q-factor for core effective area 20 to 100.at channel spacing of 50 GHz and 25 GHz.

In this chapter we simulate the 32 channel DWDM system for NRZ and RZ soliton wave formats with channel spacing of 12.5 GHz and show the Q-factor at 200 km and 3200 km for both transmission formats with EDFA gain of 20 dB and 10 dB. Here we show Q- factor performance With respect to core effective area for different values of dispersion at channel spacing of 12.5 GHz &10 GHz.

3.2 Simulation setup:

It is analyzed that 32x10 Gb/s NRZ and RZ soliton transmission formats over fiber length of 200 km and channel spacing of 12.5 GHz. Figure 3.1 shows the experimental setup of DWDM systems. Here input signal power is 0 dbm per channel. Transmitter is 32 channels WDM system with channel spacing of 12.5 GHz. Real modulator excess losses is 3 and extinction ratio is set to 30. Transmitter is followed by a booster which is having fixed power output with flat gain shape. Its maximum small signal gain is 35 dB. Fiber brag grating and Phase conjugation is used to compensate dispersion. Phase shift of phase conjugator is set to 1.57079^0 . In line optical amplifier and pre amplifier is basically fixed gain types amplifiers. At receiving end raised cosine filtering is performed and PIN is used for detection. Figure 3.2 and Figure 3.3 shows simulation setup for 200 km and 3200 km.

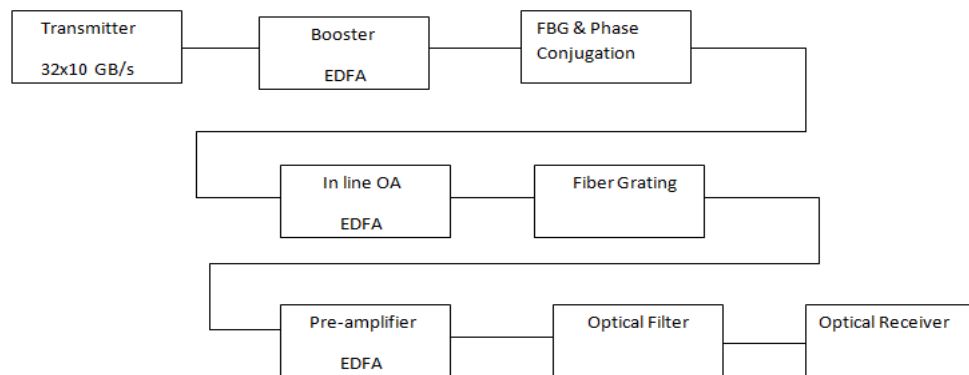

Figure 3.1: Schematic diagram of 32 channel WDM system

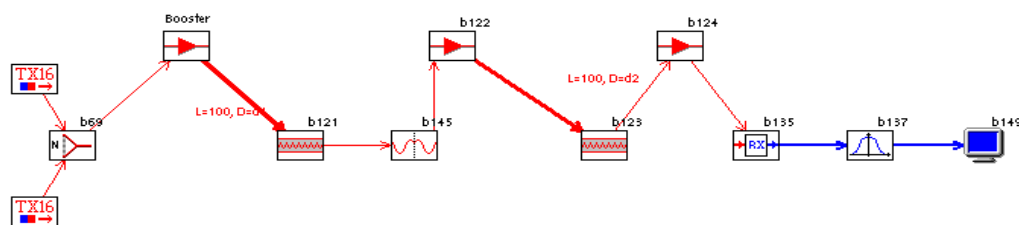

Figure 3.2: Simulation setup of 32 channel WDM system for 200 km

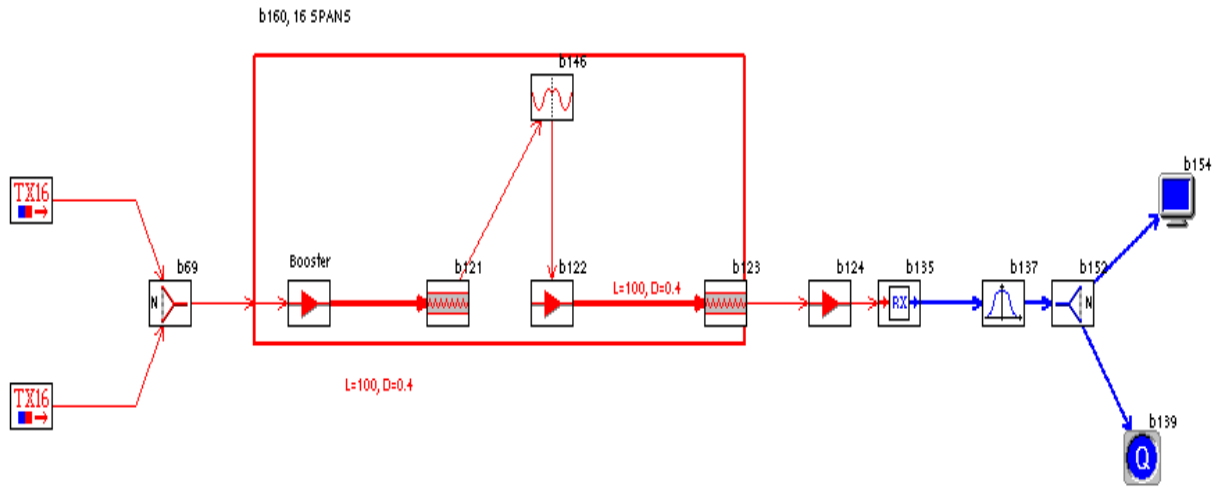

Figure 3.3: Simulation setup of 32 channel WDM system for 3200 km

3.3 Results and Discussions

Figure 3.4 shows the variation of quality factor with respect to different values of dispersion for both NRZ and RZ soliton with EDFA gain of 10 dB and 20 dB. We take the value of dispersion ranging from 0 Ps/nm/km to 4 Ps/nm/km and effective core area is set to $80 \mu m^2$. Simulation is performed at wavelength of 1550 nm, bit rate is set to 10 Gb/s, the fiber loss is .2 dB/km, non linear index coefficient is $2.6 \times 10^{-20} m^2/W$ and two 100 km spans of dispersive optical fiber is used as transmission line. In figure 3.4 we see that Quality factor improves as gain of both EDFA's is increased for both NRZ and RZ soliton. So XPM effect can be limiting factor when gain of EDFA is small. It is seen that for all dispersion range RZ soliton has better Quality factor than NRZ rectangular.

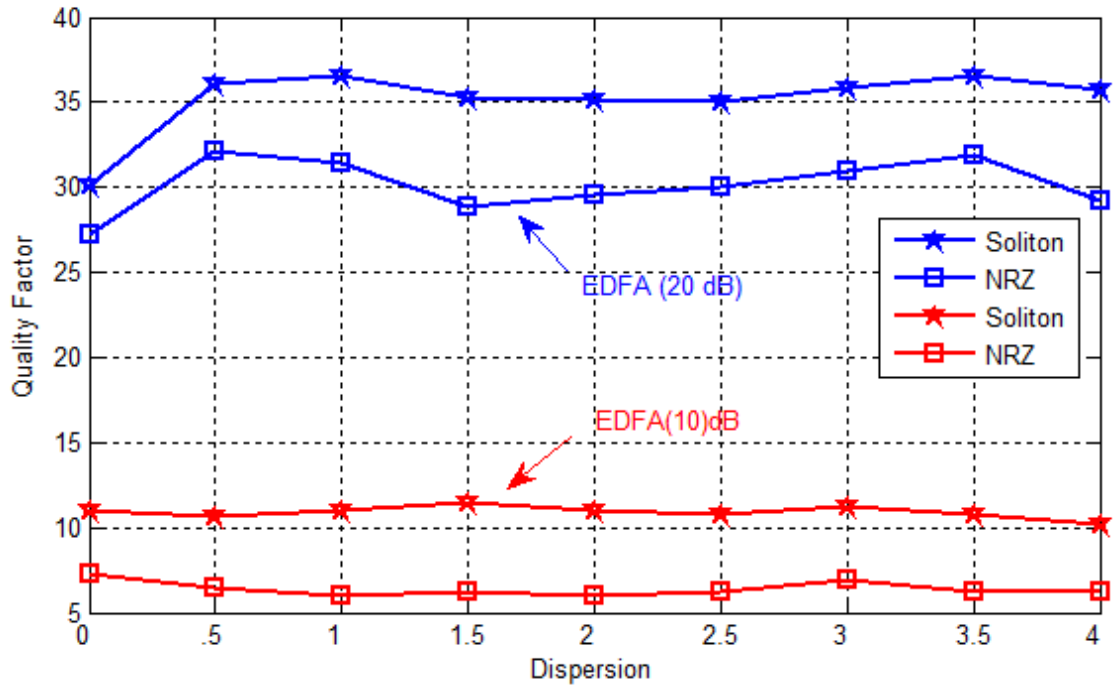

Figure 3.4: XPM effect on NRZ and RZ soliton transmission formats for different dispersion values.

Figure 3.5 to Figure 3.8 shows eye diagrams of signals suffering from XPM for NRZ and RZ soliton transmission formats. We see that with fiber length of 200 km a wide eye opening is obtained as compared to 3200 km for both transmission formats. The Quality factors values are 24.03 dB and 23.93 dB obtained for RZ soliton and NRZ respectively. So based on this output we deduce that RZ soliton has better performance compared to NRZ format.

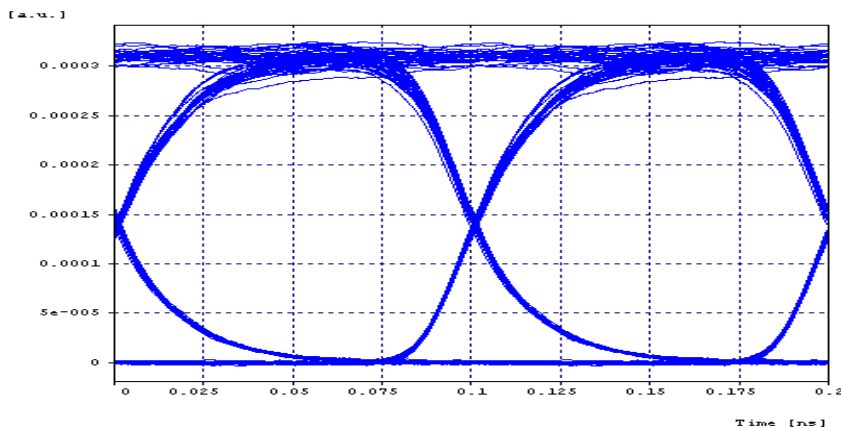

Figure 3.5: Eye diagram of NRZ format after 200 km.

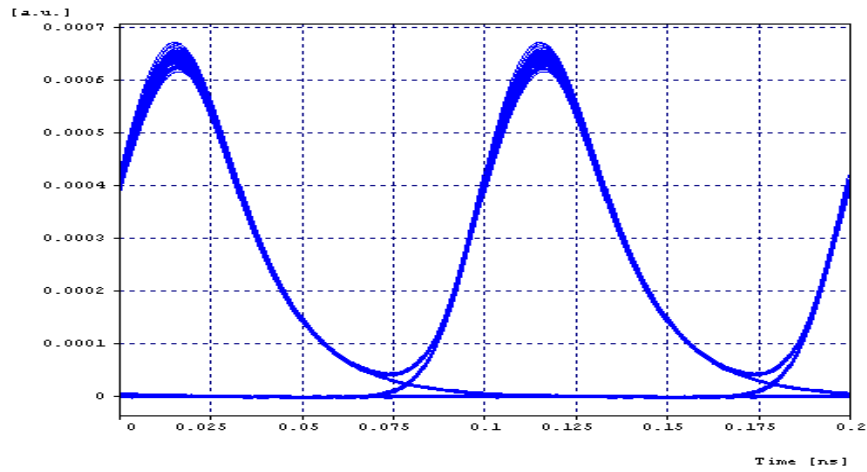

Figure 3.6: Eye diagram of RZ soliton format after 200 km

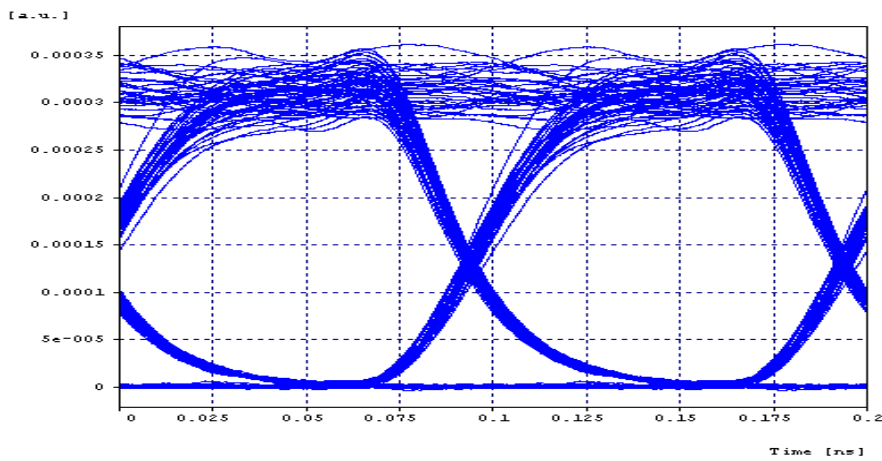

Figure 3.7: Eye diagram of NRZ format after 3200 km

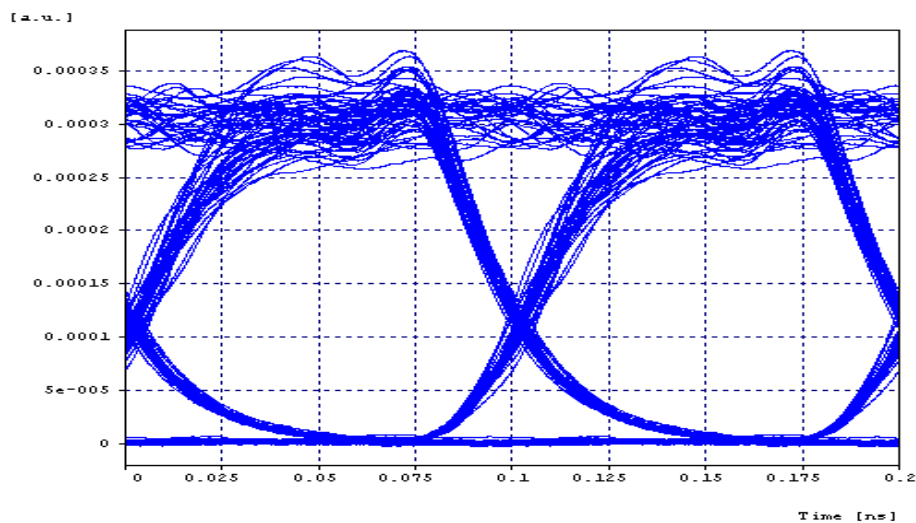

Figure 3.8: Eye diagram of RZ soliton after 3200 km.

Figure 3.9 and Figure 3.10 show the XPM effect on NRZ transmission and on RZ soliton, respectively as a function of core effective area for different values of dispersion. We show the variation of quality factor with respect to effective core area ranging from $10 \mu\text{m}^2$ to $100 \mu\text{m}^2$. Simulation is performed for dispersion values 1 Ps/(km-nm) to 4 Ps/(km-nm) and all other parameters are same as in Figure 3.4.

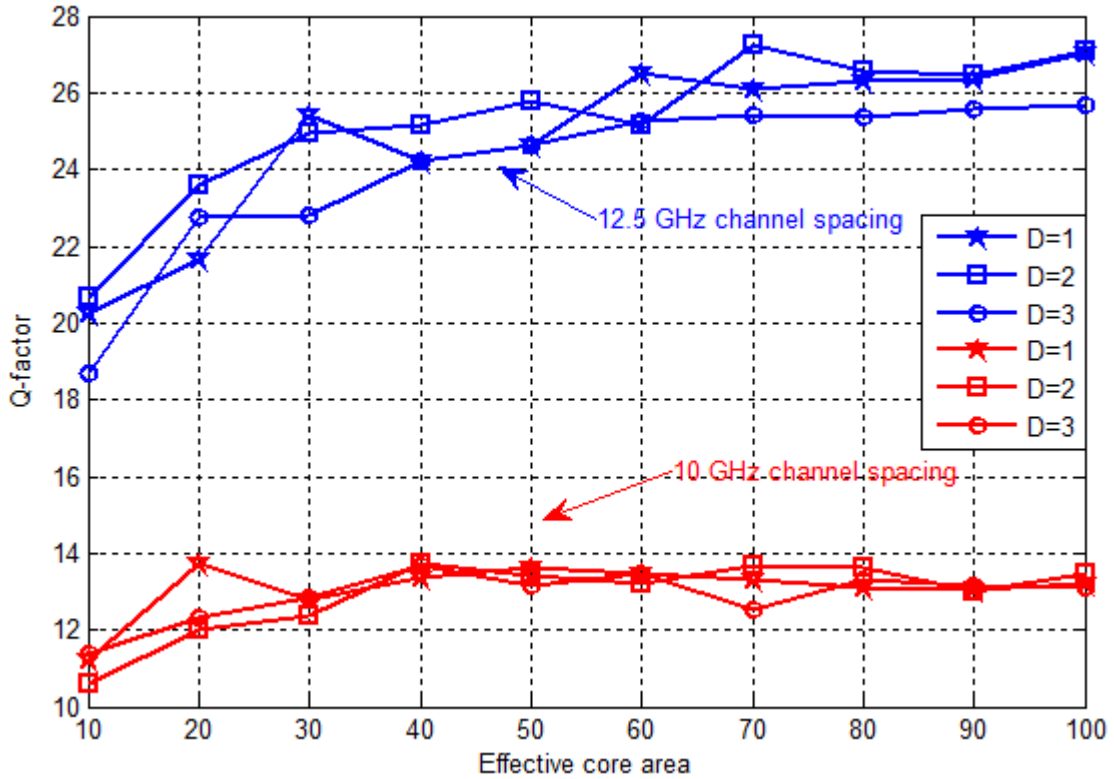

Figure 3.9: XPM effect on NRZ format for different effective area and dispersion

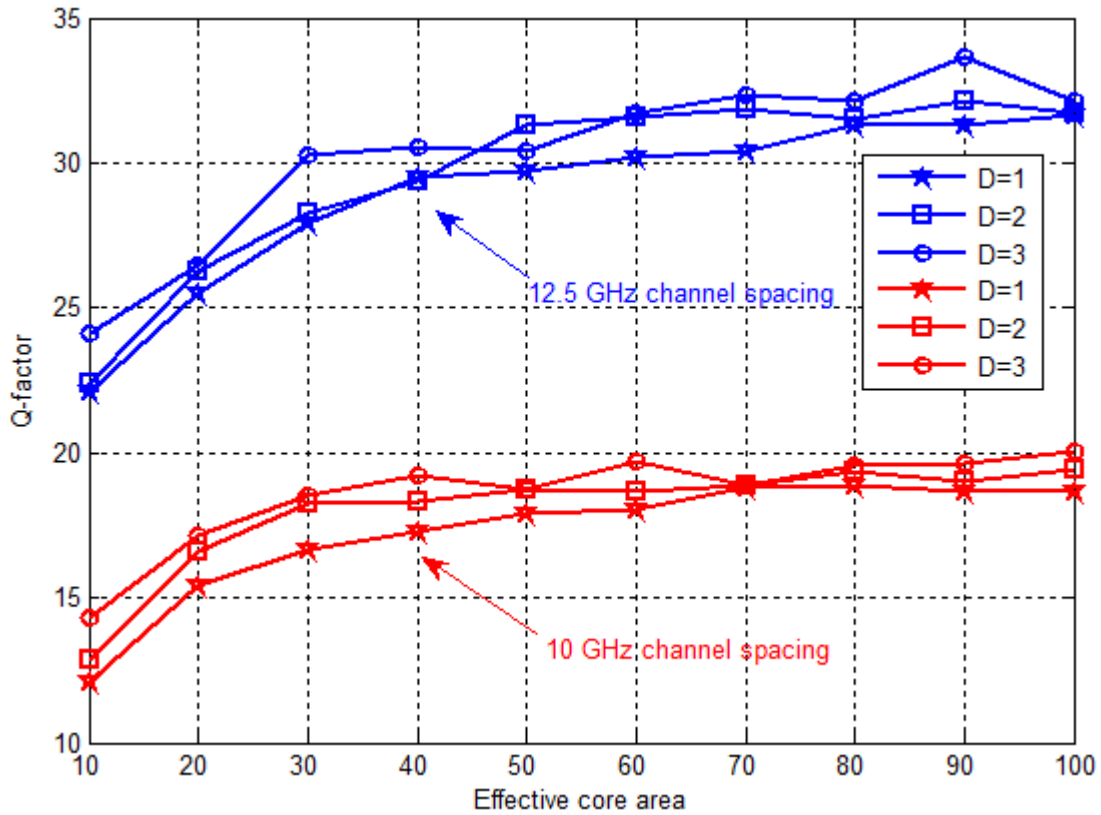

Figure 3.10: XPM effect on RZ soliton format for different effective area and dispersion

In this chapter it is calculated that Q-factor at distance of 200km and 3200 km for NRZ and RZ transmission formats. Figure 3.5 & Figure 3.6 shows eye diagram of NRZ and RZ soliton formats respectively at distance of 200 km. and has quality factor of 31.42380 dB and 34.472827 dB. Figure 3.7 & Figure 3.8 shows eye diagram of NRZ and RZ transmission respectively at 3200 km and Quality factor is 23.93 and 24.03 dB .Fig 9 & 10 shows variation of Quality factor with respect to core effective area for different values of dispersion for NRZ and RZ soliton formats respectively with channel spacing of 12.5 GHz and 10 GHz.

Table 3.1 shows the Q-factor v/s dispersion with EDFA gain of 20 dB and 10 dB for NRZ and RZ soliton modulation format. RZ soliton has more Quality-factor than NRZ modulation format for all dispersions points. For NRZ, maximum value of Q-factor is 31.84 dB at dispersion of 3 dB and EDFA gain of 20 dB. For RZ soliton maximum value of Q-factor is 36.59 dB at dispersion of 1 dB and EDFA gain of 20 dB.

Table 3.2 shows the Q-factor v/s distance for both modulation formats. Here RZ soliton and NRZ both are compared at small distance of 200 km and for large distance 3200 km, for both the cases RZ soliton is better.

Table 3.3 and Table 3.4 investigate the NRZ, RZ soliton format for core effective area $10 \mu m^2$ to $100 \mu m^2$ with channel spacing of 12.5 GHz and 10 GHz. Here we investigate the system for different dispersion values.

Table 3.1: Q-Factor v/s Dispersion

Dispersion Ps/nm/km	NRZ Q-factor(dB)		RZ soliton Q-factor(dB)	
	EDFA (20 dB)	EDFA(10dB)	EDFA (20 dB)	EDFA(10 dB)
0	27.17910	7.22340	30.13269	11.04084
0.5	32.12482	6.45224	36.10018	10.61174
1	31.43149	6.02060	36.59556	11.06008
1.5	28.85360	6.22906	35.31177	11.50809
2	29.56397	6.02060	35.20247	11.03549
2.5	30.0474	6.24708	35.00945	10.81132
3	30.99760	6.96256	35.81933	11.24849
3.5	31.84184	6.26894	36.50424	10.82936
4	29.24364	6.21789	35.77825	10.17558

Table 3.2: Q-Factor v/s Distance

Distance(km)	Q-factor (dB)	
	NRZ	RZ soliton
200	31.432380	34.472827
3200	23.932815	24.030072

Table 3.3: Q-Factor v/s core effective area for different dispersions

Core effective area μm^2	NRZ							
	Q-factor(dB) at12.5 GHz				Q-factor(dB) at10 GHz			
	D=1	D=2	D=3	D=4	D=1	D=2	D=3	D=4
10	20.237	20.690	18.869	19.676	11.205	10.590	11.367	10.760
20	21.664	23.592	22.762	22.557	13.724	12.022	12.331	12.682
30	25.429	24.941	22.794	25.119	12.790	12.352	12.867	13.725
40	24.236	25.182	24.220	24.272	13.367	13.738	13.661	14.469
50	24.609	25.806	24.626	25.354	13.640	13.417	13.136	13.229
60	26.494	25.163	25.264	25.073	13.470	13.196	13.478	13.093
70	26.077	27.218	25.438	25.283	13.337	13.700	12.521	13.341
80	26.280	26.542	25.364	25.972	13.129	13.640	13.317	14.569
90	26.341	26.460	25.575	25.939	13.041	13.011	13.146	13.154
100	27.050	27.087	25.688	26.367	13.228	13.482	13.103	13.752

Table 3.4: Q-Factor v/s core effective area for different dispersions

Core effective area μm^2	RZ Soliton							
	Q-factor at12.5 GHz				Q-factor at10 GHz			
	D=1	D=2	D=3	D=4	D=1	D=2	D=3	D=4
10	22.152	22.378	24.123	24.304	12.090	12.862	14.291	15.101
20	25.515	26.230	26.474	27.823	15.386	16.582	17.173	17.899
30	27.891	28.239	30.238	29.339	16.688	18.259	18.517	18.638
40	29.506	29.391	30.561	29.861	17.306	18.312	19.187	19.818
50	29.723	31.299	30.398	31.146	17.875	18.701	18.717	20.043
60	30.225	31.601	31.709	31.195	18.051	18.679	19.675	19.299
70	30.427	31.837	32.343	30.591	18.792	18.868	18.877	19.841
80	31.297	31.509	32.168	32.245	18.840	19.338	19.588	19.906
90	31.301	32.159	33.675	32.642	18.681	19.030	19.613	19.923
100	31.623	31.746	32.157	31.739	18.654	19.429	20.026	19.808

3.4 Conclusion

In this chapter we concluded that by increasing the gain value of EDFA's, the Quality factor is improved for both NRZ and RZ soliton transmission formats. RZ soliton has better performance than NRZ both at 200km. and at 3200km in terms of Quality factor. XPM effect may reduce by increasing the channel separation. We conclude that RZ soliton is less affected to XPM so it is efficient transmission than NRZ format in 32 channel DWDM system.

Performance Analysis of Ring Optical Network with OADM for different Transmitting Formats.

In this chapter, ring optical network has been verified and analyzed at each node with bit rate of 2.5 Gbps, 5Gbps and 10 Gbps for different modulation formats like NRZ rectangular, NRZ raised cosine, RZ soliton, RZ super gaussian, RZ raised cosine and RZ rectangular. The distance between the nodes is set to 120km (SMF+DCF). Semiconductor optical amplifier after each node enhances the power level. The effect of insertion losses for a wide range of 40 dB to 100 dB is analyzed and it seen that RZ-soliton is performing better among all modulation driving schemes. It is seen that by using RZ soliton format system can exist up to 90 dB of insertion loss. The effect of OADM bandwidth is also analyzed and it is seen that after 10 GHz bandwidth there is huge rise in the system performances for NRZ rectangular and RZ soliton.

4.1 Introduction:

Optical networks are spreading outwards from internet backbones to corporation and even to the home. Optical technologies can meet bandwidth needs with cost-effectiveness. Metropolitan networks impose a bandwidth bottleneck between the local access networks and the backbone [18]. The deployed circuit switched ring networks are inefficient for dynamic traffic. So efforts are being towards designing of Packet switched network combined with WDM to enhance the bandwidth [2]. In ring network inter channel crosstalk can arise from optical add drop multiplexer and from XPM.OADM is used to add and drop any frequency at intermediate nodes without effecting other channels. OADM enhances the capacity of the network as dropped wavelength can be reused [19]. In particular optical cross connects (OXC) and optical add drop multiplexer (OADM) provide wavelength routing capabilities .so that each channel could be optically routed through All optical network (AON) to its own wavelength path [20].

Vinod Kumar et al. [9] presented the results on ring network with 4 nodes only and separation between the node is set to 12.5km and 25 km. he also present performance of ring network at filter bandwidth range 10 MHz to 40 MHz Surinder Singh [22] presented ring topology with 27 nodes with optimized value of SOA and separation between nodes is only 1.1km.he shows that the input power above the saturation power of SOA degrades the performance of the system .Willner et al. [23] reported a ring network accommodate 25 nodes using erabium doped fiber amplifier at a bit rate of 2.5 Gbps. Rajneesh Randhawa et al. [24] reported a ring network having 12 nodes with one channel is added and another is dropped. Analysis of the system is performed at reference bit rate of 10 Gbps

To the date no work is reported for large no. of nodes in ring network and for insertion losses and bandwidth of Optical add drop multiplexer.

In this chapter we simulate 36 node ring network with 120 km separation between successive nodes and use SOA after each node. We vary the bandwidth from 5 GHz to 20 GHZ and vary the insertion loss from 40 dB to 100 dB of OADM and check existence of the system. Insertion loss of OADM and its different values of bandwidth is analyzed in terms of BER, Q-Factor and eye opening

4.2 Theory:

In this chapter we have designed ring architecture for different modulation formats. The brief description of ring network and modulation format is given below.

4.2.1 Ring Network:

The ring optical network is a unidirectional fiber ring network that comprises N nodes, where N is number of wavelengths. Each node is equipped with array of fixed tuned transmitter and one fixes tuned optical receiver operation on wavelength that identifies the node [24]. Any node j drops wavelength j from the ring, so to communicate with node j, another node i have to transmit data with laser operating on wavelength j. All wavelengths are slotted with slot length equal to transmission time of fixed size data packet plus guard time [25]. Because ring topologies provide only one path between any two nodes, so ring network can fail completely

by failure of single link. FDDI overcome this problem by sending data in clockwise and anticlockwise in the event of break [26].

4.2.2 Modulation Formats:

A Modulator driver converts the binary sequence of ones and zeros into electrical signal. Several mapping drivers are available such as NRZ and RZ rectangular, NRZ and RZ raised cosine, RZ super gaussian, RZ soliton.

4.3 Simulation setup:

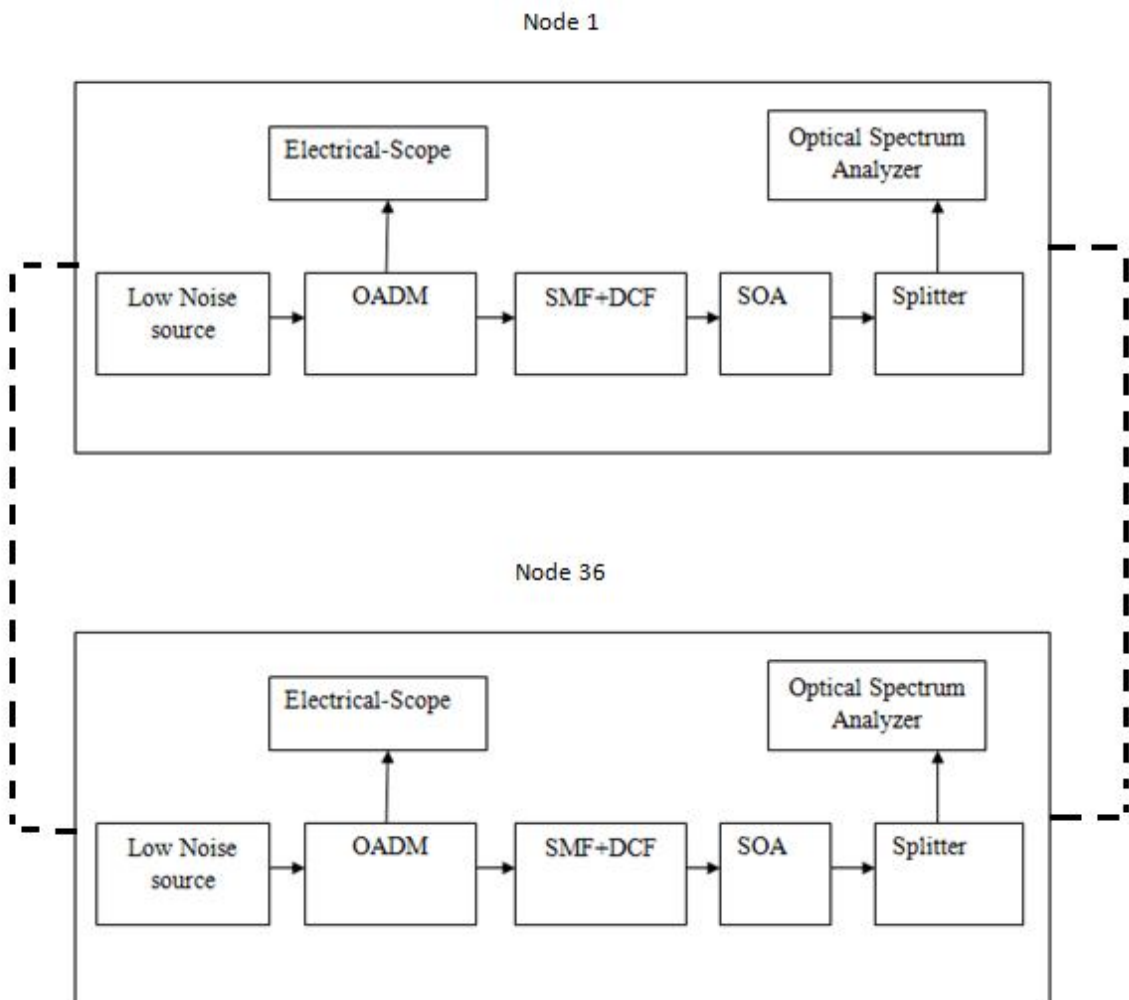

Figure 4.1: Block diagram of simulation setup

Figure.4.1 shows the block diagram representation of 36 nodes ring network with one channel added and another channel dropped at each node. At each node electrical scope and optical spectrum analyzer is attached to analyze the signal in terms of Q-factor, BER, eye opening, jitter and power. Low noise source is used as input source and it is connected to OADM of first node. OADM adds and drop a frequency at each node. After OADM we used a fiber channel, here we used a fiber of length 100km +20km is used between successive nodes. Here 100 km Single mode fiber and 20 km Dispersion compensation fiber is used. SMF have dispersion of 16 ps/nm/km and DCF has dispersion of 80 ps/nm/km. so we used 1/5th length of DCF to compensate dispersion. After each node semiconductor optical amplifier is used to boost the signal. Saturation power of SOA is set to 9.15 mw , input and output insertion losses is set to 3 dB The node composed of optical adds drop multiplexer, transmitter, receiver.

The frequencies of the nodes are f1, f2, f3 and so on up to f36. All these frequencies are used in circular fashion such that at node 1 frequency f1 is added and f36 is dropped and at next node f3 is added and f1 is dropped. Simulation of network is done at reference frequency 193.0 THz at bit rate of 10 Gbps. For OADM laser power is set to 0 dbm. PRBS sequence degree is set to 7, Rx_elt filter bandwidth is 8 GHz, Rx_opt filter bandwidth is set to 40 GHz and crosstalk is fixed at -90 dB. Simulation setup of network is shown in Figure 4.2

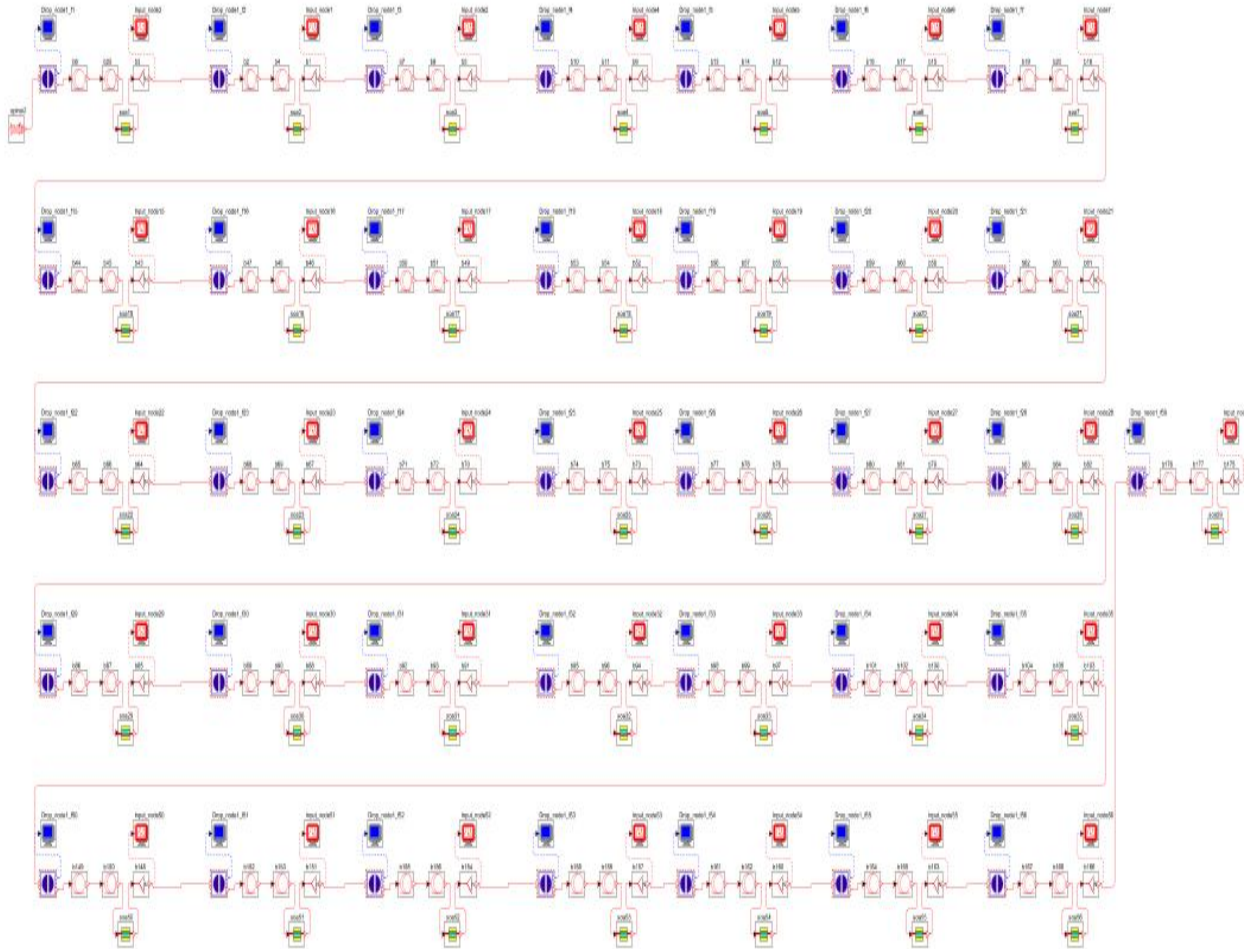

Figure 4.2: Simulation Setup

4.3 Result and Discussions

Simulation is performed at four different Bandwidth of OADM and we get the better result at 20 GHz so that for 20 dB bandwidth we vary the insertion loss of OADM at different bit rates. The results in the form of Q-factor and BER for various bit rates are given below:

Figure 4.3 and Figure 4.4 are Bandwidth v/s Quality factor and Bandwidth v/s BER respectively for bit rate of 2.5 Gbps. Here it is clearly seen that NRZ rectangular and RZ soliton are better than all other formats. For a bandwidth of 20 GHz Quality factor for NRZ rectangular and RZ soliton is 33.69 dB and 33.59 dB. For 10 GHz bandwidth only NRZ rectangular and RZ soliton has survivable BER value. For NRZ rectangular and RZ soliton at 10 GHz BER is $1.61e^{-19}$ and $2.17e^{-15}$ respectively.

Figure 4.5 and Figure 4.6 are Bandwidth v/s Quality factor and Bandwidth v/s BER respectively for bit rate of 5 Gbps. Here we see that as bit rate increases from 2.5 Gbps to 5 Gbps Quality factor slightly reduces to 32.8 and 32.6 for NRZ rectangular and RZ soliton respectively with 20 GHz bandwidth. For bandwidth of 10 GHz only NRZ rectangular and RZ soliton has survivable BER. For NRZ rectangular and RZ soliton at 10 GHz BER is $4.1e^{-14}$ and $2.1e^{-13}$ respectively.

Figure 4.7 and Figure 4.8 shows Bandwidth v/s Quality factor and Bandwidth v/s BER respectively for bit rate of 10 Gbps. Here we see that Q-factor is 29.78 and 29.73 for NRZ rectangular and RZ soliton. Here in is seen that up to bandwidth of 10 GHz no any modulation format has survivable BER. For bandwidth between 10 GHz to 20 GHz NRZ rectangular and RZ soliton become better than rest all.

One other parameter which we analyzed is the insertion loss of the OADM. From Figure 4.9 to Figure 4.14 shows the variation of Q-factor and BER with respect insertion loss for different bit rates.

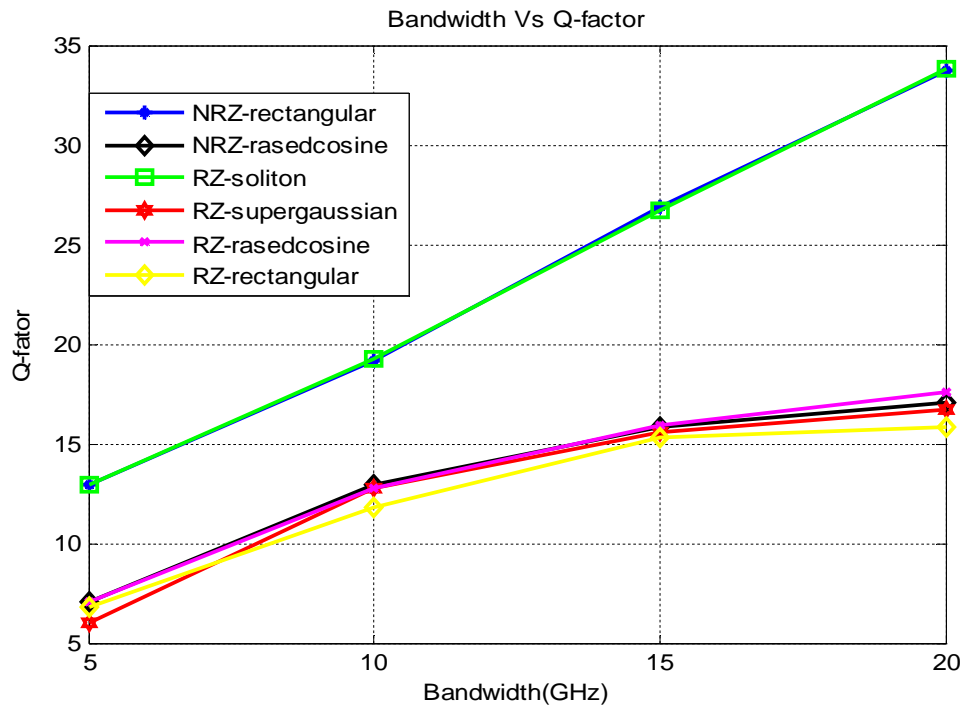

Figure 4.3: Bandwidth v/s Q-factor (2.5Gbps)

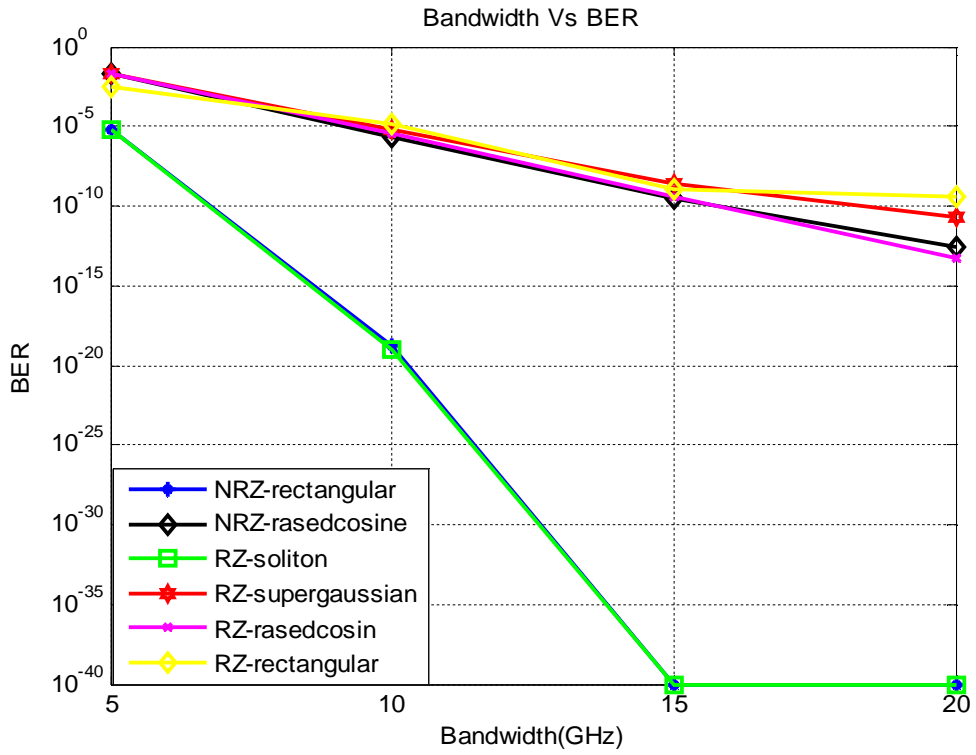

Figure 4.4: Bandwidth v/s BER (2.5Gbps)

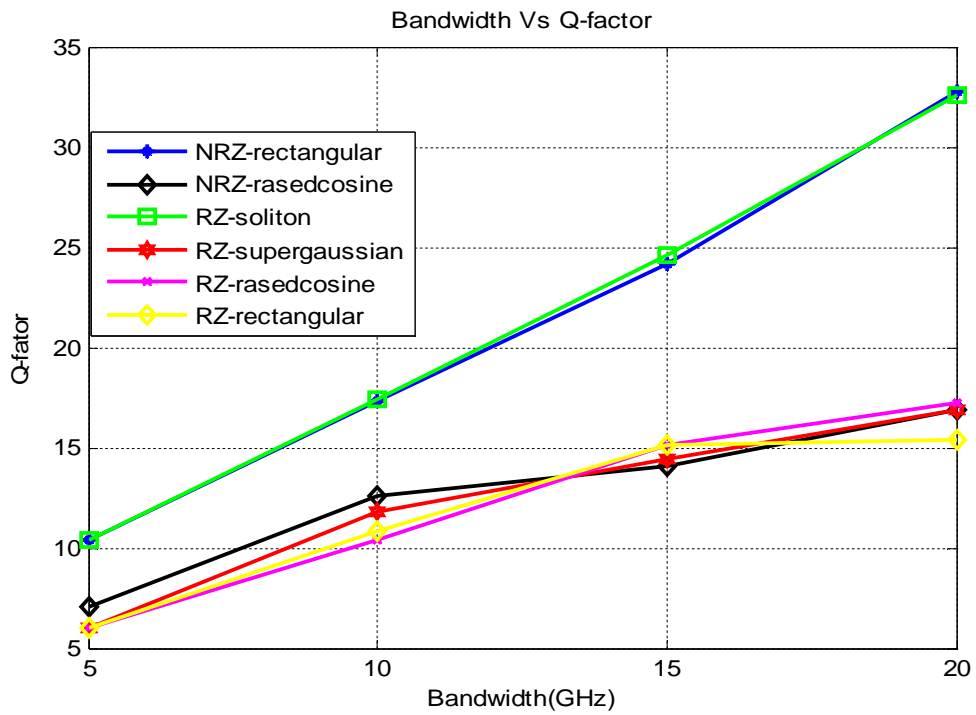

Figure 4.5: Bandwidth v/s Q-factor (5 GBps)

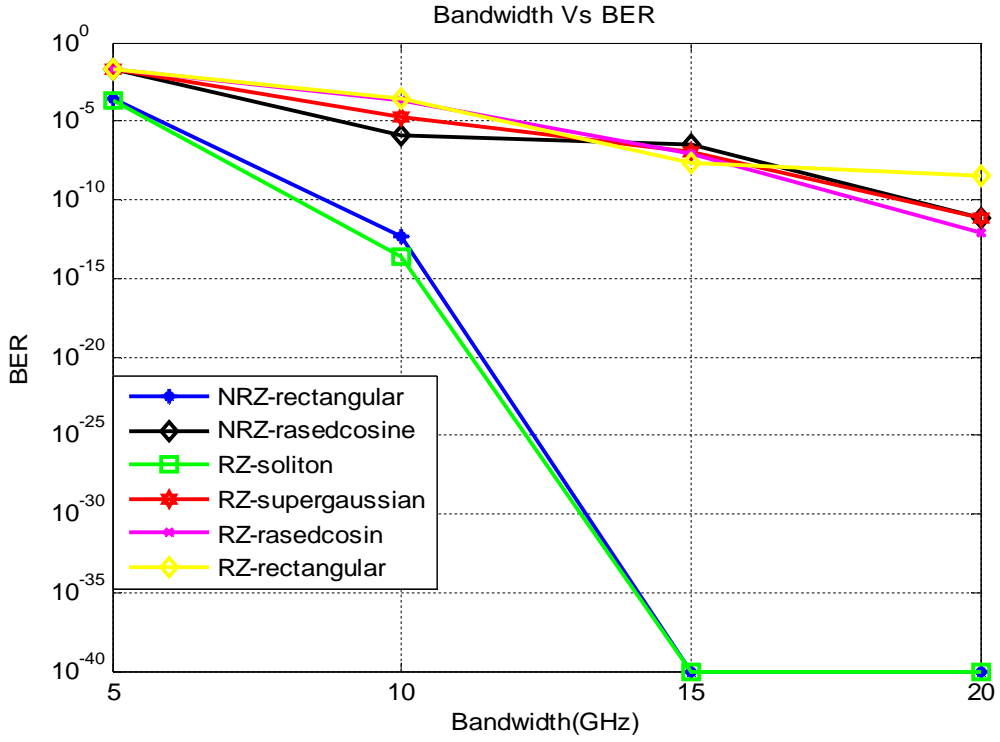

Figure 4.6: Bandwidth v/s BER (5 Gbps)

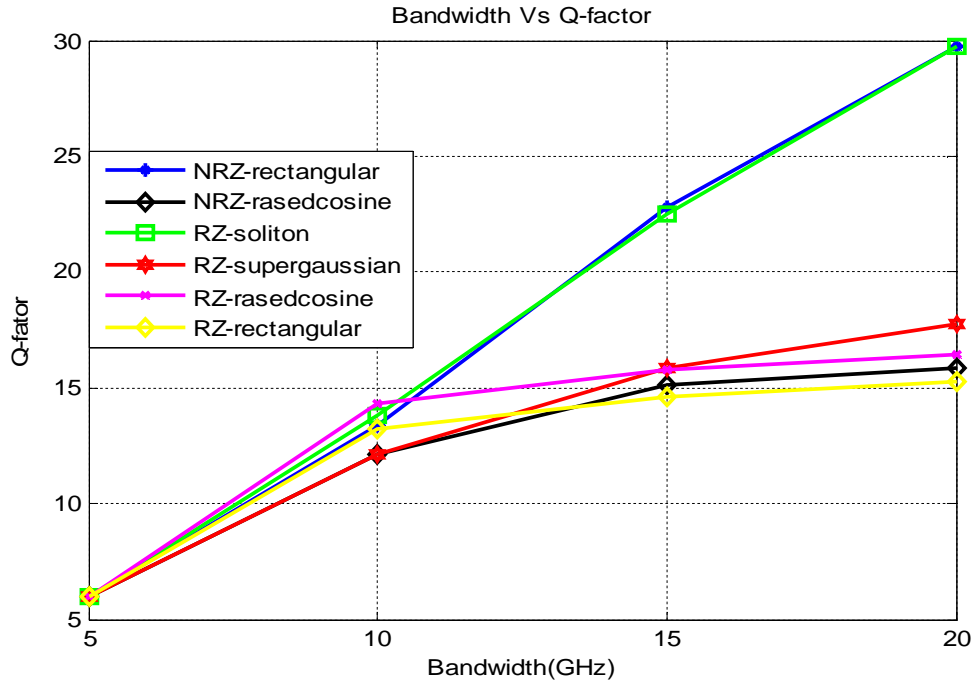

Figure 4.7: Bandwidth v/s Q-factor (10 Gbps)

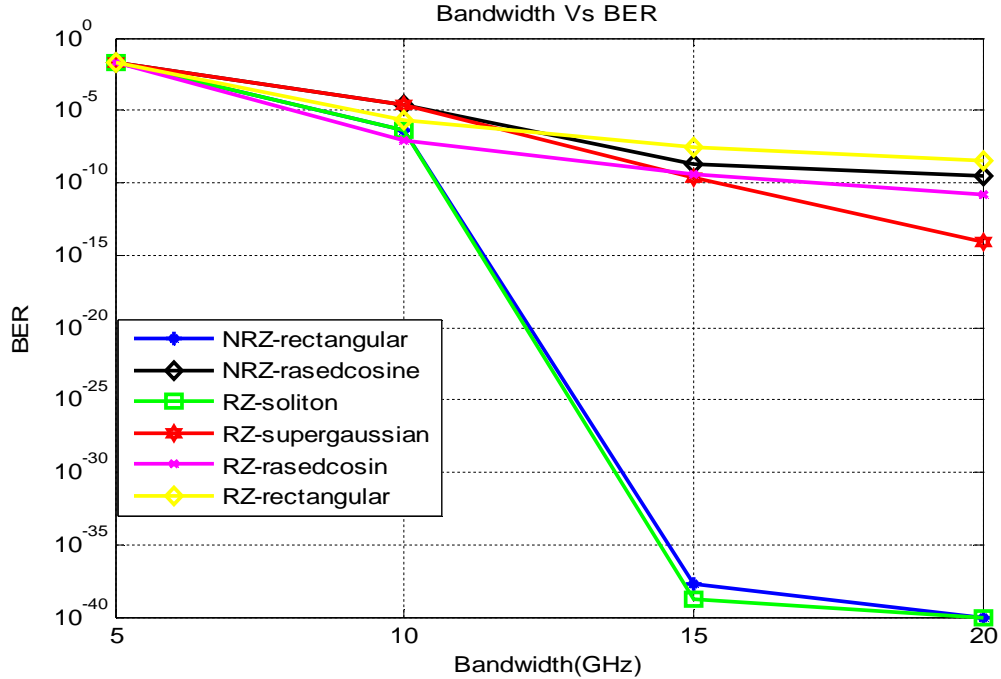

Figure 4.8: Bandwidth v/s BER (10 Gbps)

Figure 4.9 and Figure 4.10 shows the variation of Q-factor and BER with respect to insertion loss for bit rate of 2.5 Gbps. For insertion loss of 40 dB, Q-factor is 33.74 for NRZ rectangular format and RZ soliton and has survivable BER up to insertion loss of 90 dB. Figure 4.3 shows RZ rectangular has worst performance among all modulation formats at 2.5 Gbps here for this format system cannot exist for insertion loss more than 50 dB.

Figure 4.11 and figure 4.12 shows the variation of Q-factor and BER with respect to insertion loss for bit rate of 5 Gbps. For insertion loss of 40 dB, Q-factor is 32.85 and 32.88 for NRZ rectangular and RZ soliton modulation format and has survivable BER up to insertion loss of 85 dB.

Figure 4.13 and Figure 4.14 shows Q-factor and BER with respect to insertion loss for bit rate of 10 Gbps. At such bitrate It is clearly seen that RZ soliton is better among all techniques.

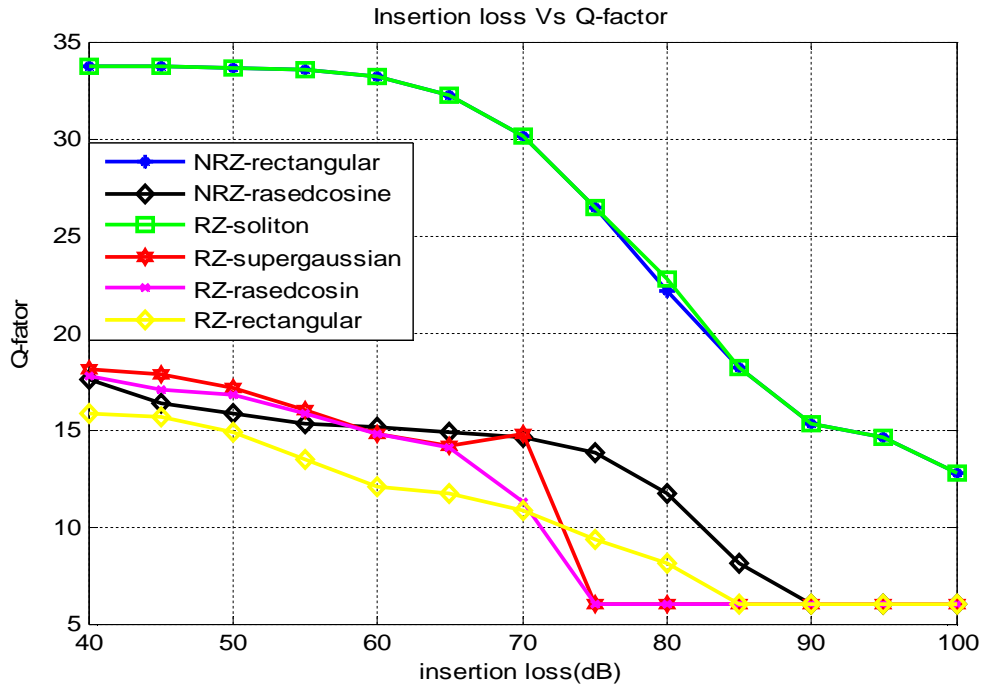

Figure 4.9: Insertion loss v/s Q-factor (2.5 Gbps)

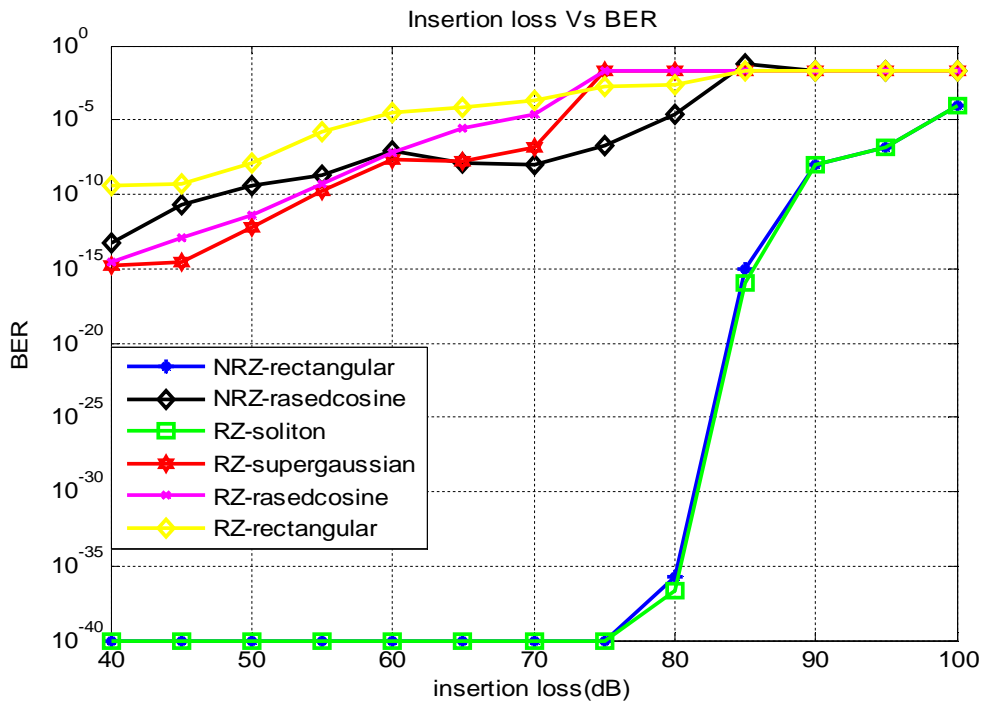

Figure 4.10: Insertion loss v/s BER (2.5 Gbps)

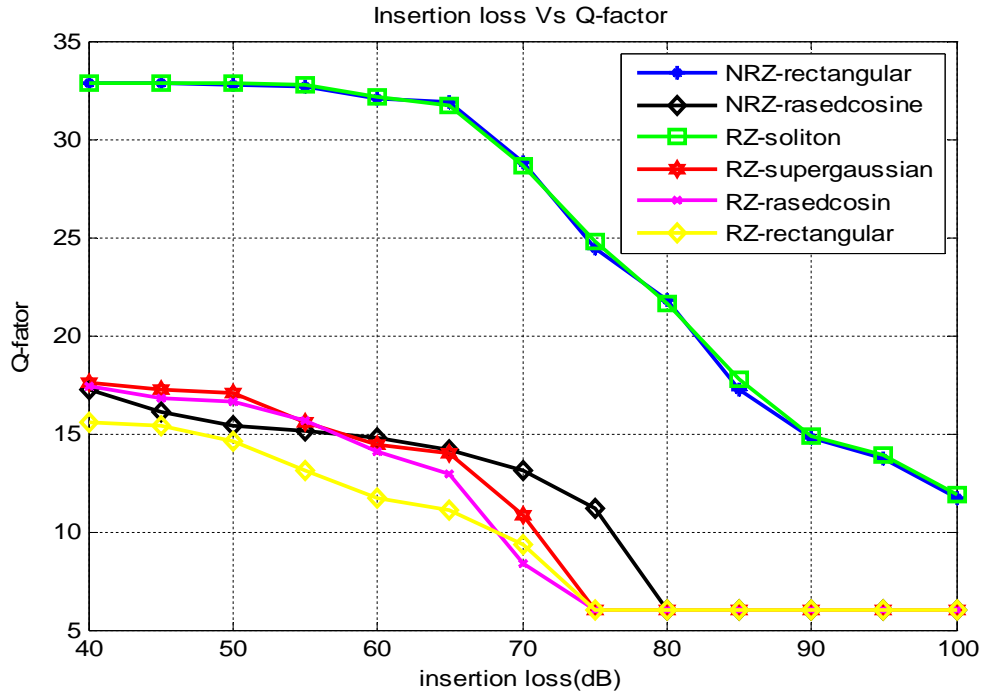

Figure 4.11: Insertion loss v/s Q-factor (5 Gbps)

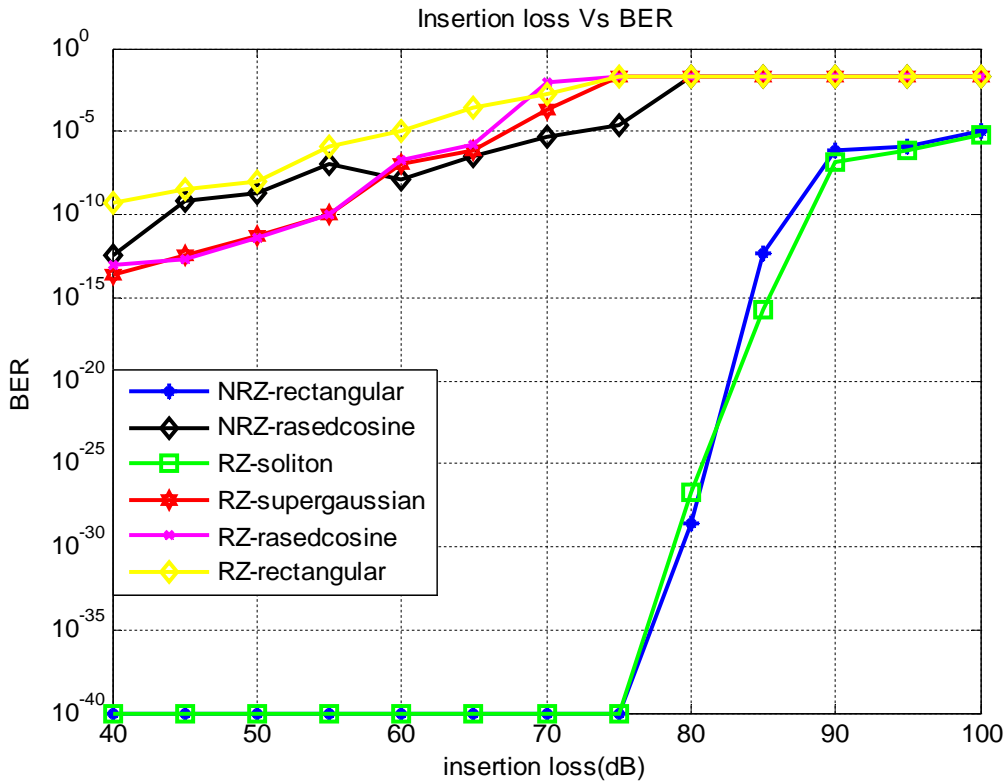

Figure 4.12: Insertion loss v/s BER (5 Gbps)

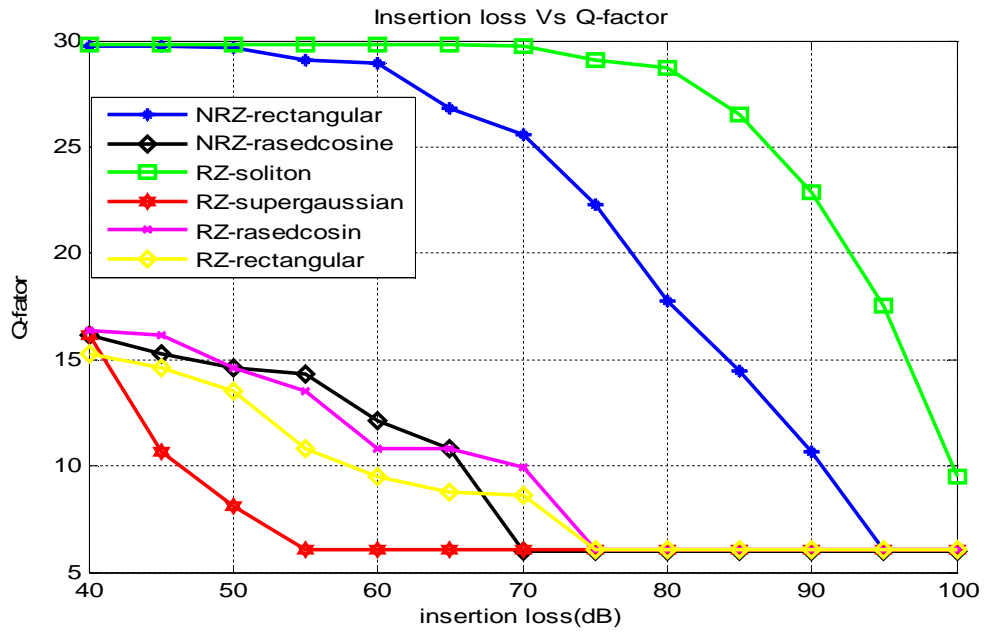

Figure 4.13: Insertion loss v/s Q-factor(10 Gbps)

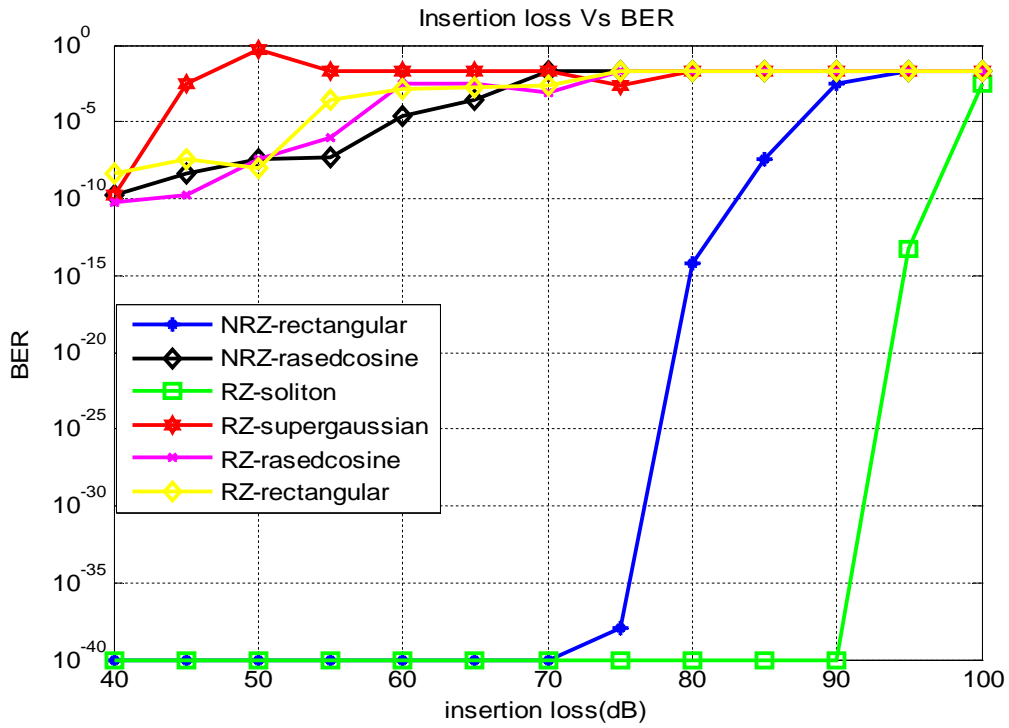

Figure 4.14: Insertion loss v/s BER(10 Gbps)

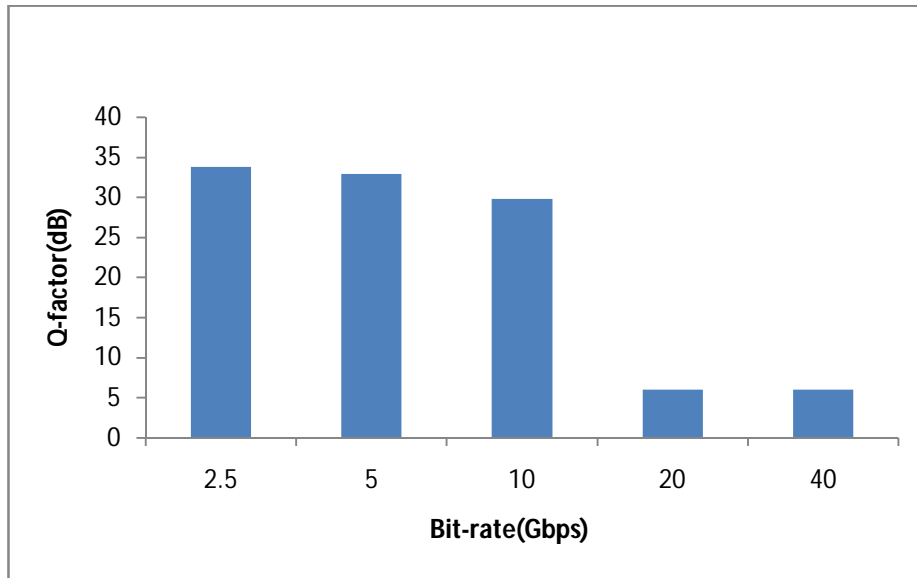

Figure 4.15: Q-Factor v/s Bit-rates for RZ soliton

Figure 4.15 is Quality factor v/s Bandwidth with insertion loss of 40 dB and bandwidth of 20 dB, for RZ soliton. Here Q-factor is shown for bit rate up to 40 Gbps. In is seen that for bit rate of 2.5 Gbps it has maximum Q-factor (33.74 dB) and as we move towards higher bit rates, Q-factor reduces. It is clearly seen that system is not survivable for bit rate of 20 Gbps and 40 Gbps At much higher rates Q-factor is 6.02 dB only.

4.4 Conclusion

In this chapter, various values of bandwidth and insertion losses of OADM are analyzed. It is concluded that at bandwidth less than 10 GHz system can exist for 2.5Gbps and 5Gbps for RZ soliton and NRZ rectangular format. After 10 GHz there is huge rise in the Quality factor of NRZ rectangular and RZ soliton. It is also concluded that system can exist up to 90 dB of insertion loss for RZ soliton modulation with 10 bit rate of 10 Gbps. It is seen that for bit rate of 20 Gbps and 40 Gbps Quality factor for RZ soliton is 6.02 dB.

CHAPTER 5

To investigate the performance of 256 channel WDM system with channel spacing of 25 GHz and 50 GHz.

In this chapter we investigate the performance of 256 channel WDM system with channel spacing of 25 GHz and 50 GHz with bit rate of 2.5 Gbps at different distances. We analyze the result at the receiving frequencies 193.025 GHz, 193.225 GHz, 193.35 GHz, 193 GHz, 195.2GHz, 195.075GHz, 195.175GHz and 195.425 GHz. It is seen that for channel spacing of 25 GHz Quality factor becomes low than 15 dB so after 140 km so system cannot exist after 140 km. on the other hand for 50 GHz Quality factor is more than 15 dB at distance of 140 km.

5.1 Introduction

Wavelength-division multiplexing (WDM) is an approach that can exploit the huge opto-electronic bandwidth mismatch by requiring that each end user's equipment operate only at electronic rate, but multiple WDM channels from different end-users may be multiplexed on the same fiber. Under WDM, the optical transmission spectrum is carved up into a number of non-overlapping wavelength (or frequency) bands, with each wavelength supporting a single communication channel operating at whatever rate one desires, e.g., peak electronic speed[27]. Thus, by allowing multiple WDM channels to coexist on a single fiber, one can tap into the huge fiber bandwidth, with the corresponding challenges being the design and development of appropriate network architectures, protocols, and algorithms.[5] Also, WDM devices are easier to implement since, generally, all components in a WDM device need to operate only at electronic speed; as a result, several WDM devices are available in the marketplace today, and more are emerging[28].

Research and development on optical WDM networks have matured considerably over the past decade. They are being increasingly deployed by telecom network operators all over the

world. The next generation of the Internet is employing WDM-based optical backbones, leading to IP-over- WDM networks [29]. In such a network, end-users - to whom the architecture and operation of the backbone will be transparent except for significantly improved response times - will attach to the network through a wavelength sensitive switching/routing node [30]. An end-user in this context need not necessarily be terminal equipment, but the aggregate activity from a collection of terminals including those that may possibly be feeding in from other regional and/or local sub networks - so that the end-user's aggregate activity on any of its transmitters is close to the peak electronic transmission rate [31].

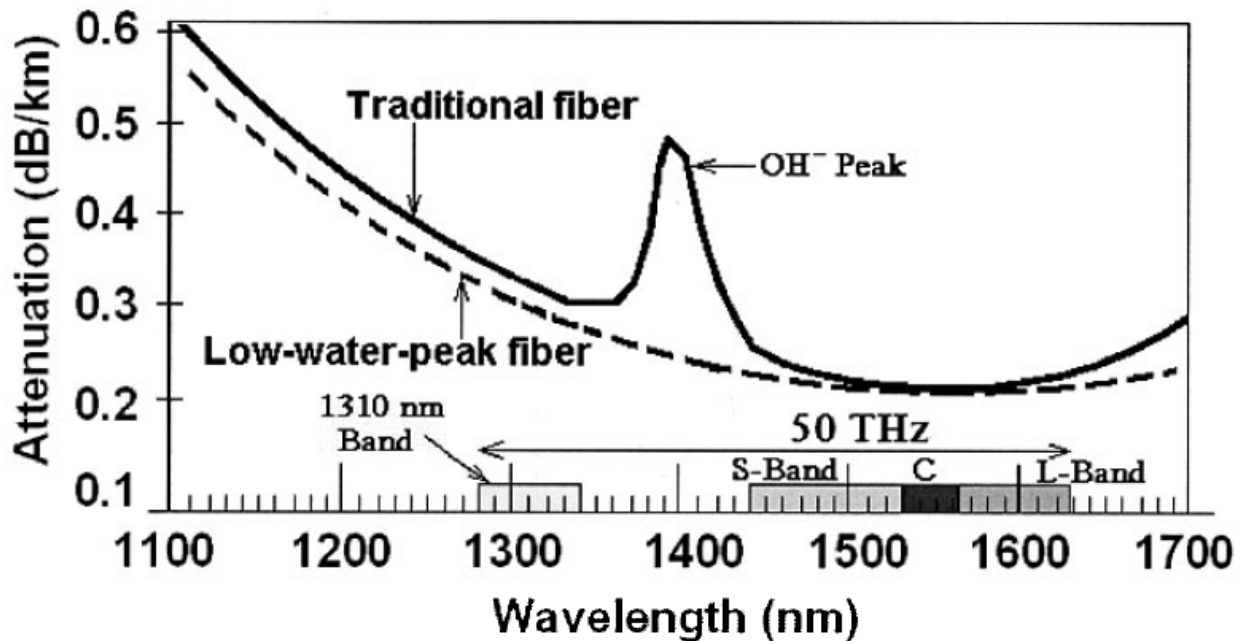

Figure 5.1: Attenuation v/s Wavelength [6]

S. Susskind et al. [32] presented the transmission limits of a 40 channels DWDM system at 10 Gb/s, without using optical amplification in any part of the system. The channels were distributed between the wavelengths of 1532.7 nm (channel 1) and 1563.9 nm (channel 40). Er. Kawal Preet Singh et al. [33] presented different WDM systems. The WDM system has been affected by dispersion and non-linear effects. They have also analyzed the use of PIN and APD photo detectors. They had designed three WDM systems and observed their response using different dispersion values.

Till now no work has done for upto 256 channels in WDM system.

In this implementation we simulate the 256 channel DWDM system for channel spacing of 25GHz and 50 GHz for distance range up to 150 km. we seen the result in the form of Q-factor and bit error rate.

Theory:

Wave division multiplexing (WDM) and dense wave division multiplexing (DWDM) require optics to combine signals generated by separate transmitters at one end and to separate the optical channels for processing in separate optical receivers at the other end [34]. The process of packing channels closely together increases the capacity but also makes the job of separating them much more difficult. Transmission systems based on optical fiber (DWDM) technology have indeed revolutionized the field of communication [35]. This is because the usable transmission bandwidth on the optical fiber is so enormous that it is capable of transmitting multi channels over long distances. The revolutionary growth in Internet traffic is forcing network operators to deploy ever higher transmission capacities in their terrestrial fiber backbone networks [36]. It is anticipated that in the near future, it will be necessary to offer multi terabit capacities over a single fiber, based on the use of this DWDM technology. To cope with this demand, it is likely that the next generation of Wavelength Division Multiplexing (WDM) systems will use a 40 Gbit/s or higher bit rate. DWDM is a technology that uses multiple wavelengths to transport a large number of individual channels, typically at bit rates of 2.5 Gbits/sec or higher [37].

5.2 Simulation setup:

Figure. 5.3 shows the simulation setup of 256 channel WDM system. Here we used 16 sixteen channel transmitters. Each Tx-16 contains 16 Tx-1. The internal structure of the Tx-1 is shown in Figure. 5.2. Here Non return to zero transmitting formats is used and modulator is \sin^2 MZ. Continuous wave Lorentzian is used as laser source. All 256 channels are combined in splitter and then boosted by a booster. After that optical spectrum analyzer is used to get the spectrum of the signal. A single mode fiber is used for transmission of signal. A phase conjugator with fiber grating is used to reduce the dispersion effect. Fixed power EDFA is used to enhance the signal level before reaching to receiving end. At receiving end

numbers of receiver with different frequencies is used to receive the signal. The internal structure of receiver is shown in Figure. 5.5. Here raised cosine filter is used to select the particular frequency and for receiving PIN detection is used. A five pole electrical Bessel filter is used at the end.

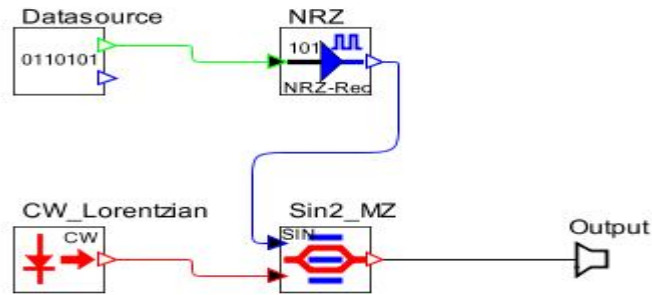

Figure 5.2: Internal structure of Tx-1

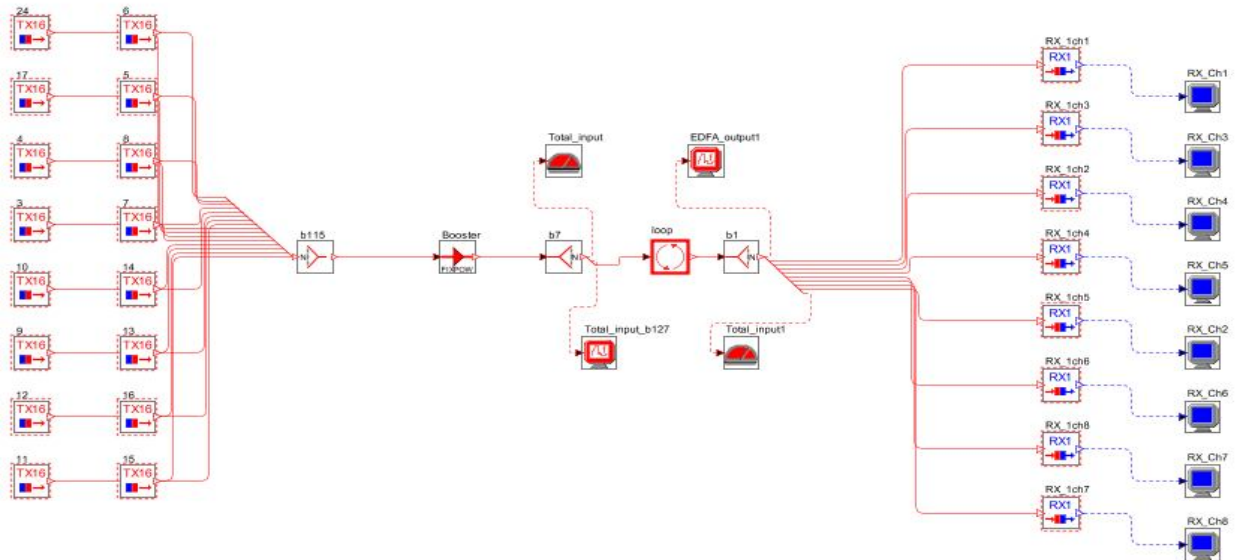

Figure 5.3: Simulation setup for 256 Channel.

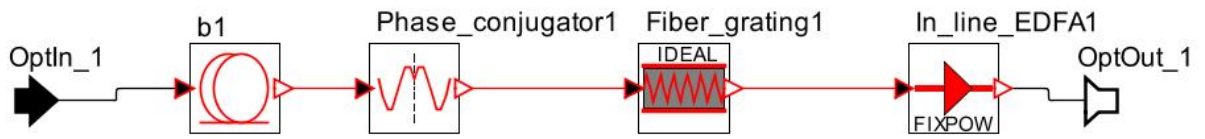
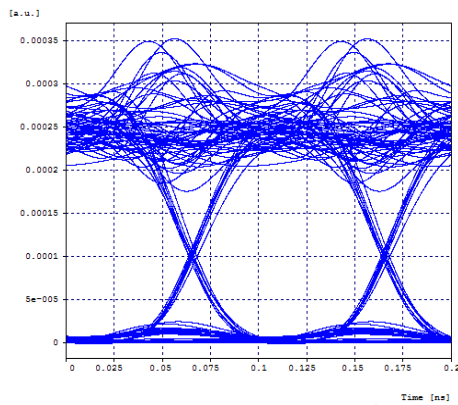

Figure 5.4: Fiber with dispersion removing techniques.

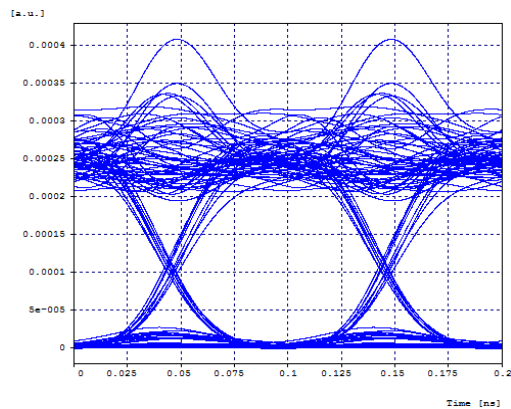

Figure 5.5: Internal Structure of Receiver.

RESULT AND DISCUSSION:



D=30 km(a)



D=60km(b)

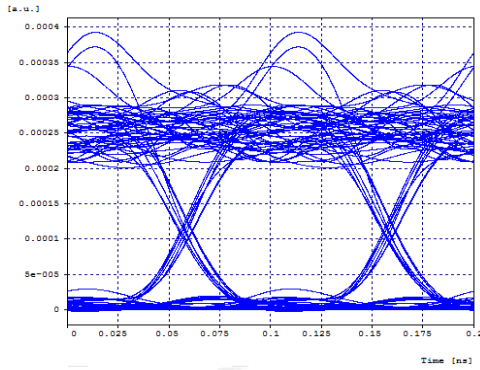

D=90km(c)

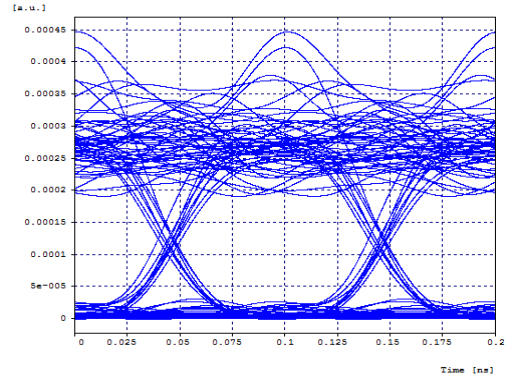

D=120km(d)

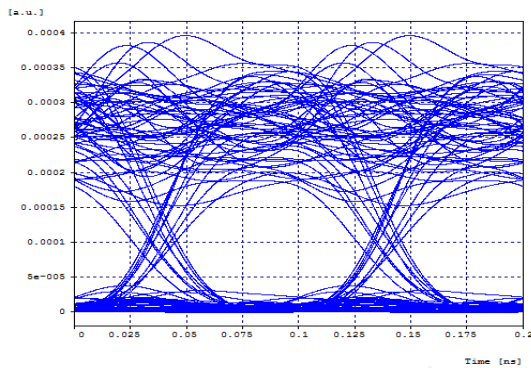

D=150km(e)

Figure 5.6: Eye diagrams for 25 GHz spacing

Figure 5.6 shows the eye diagrams for channel spacing of 25 GHz. Here we vary the length of the fiber from 30km to 150 km and see that as we increase the length of the fiber the opening of eye reduces and so Quality factor reduces. So by using 25 GHz of channel spacing system cannot exist for distance 150 km.

Figure 5.7 shows the eye diagrams for channel spacing of 50 GHz. Here we vary the length of the fiber from 30km to 150 km and see that as we increase the length of the fiber the opening of eye reduces and so Quality factor reduces. So by using 50 GHz of channel spacing up to distance of 150km system can exist.

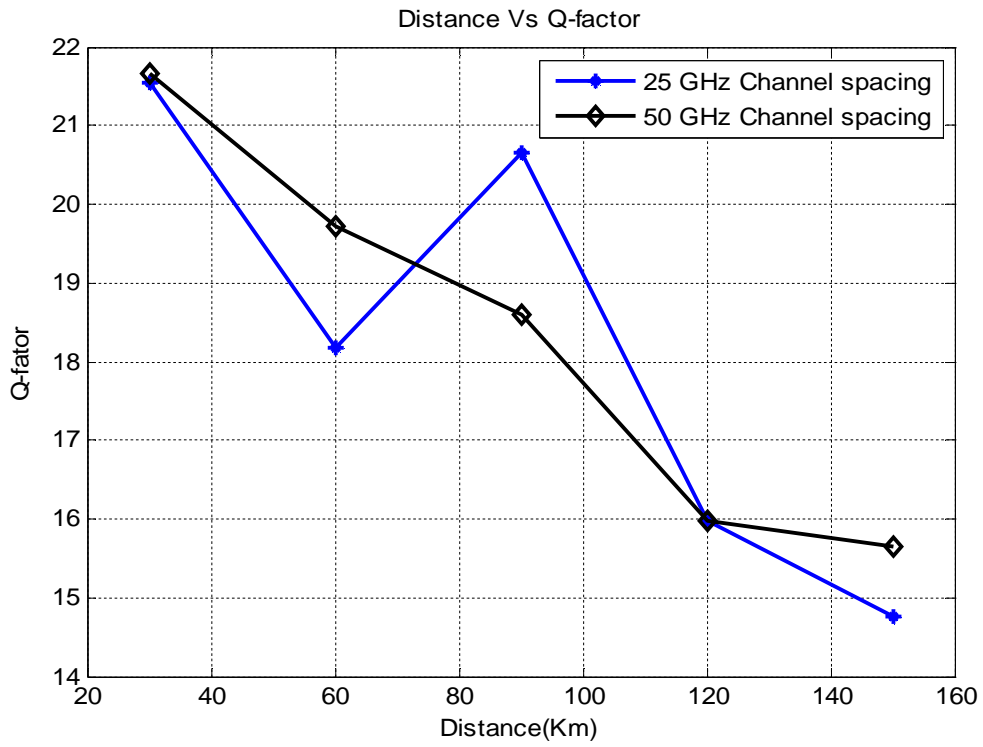
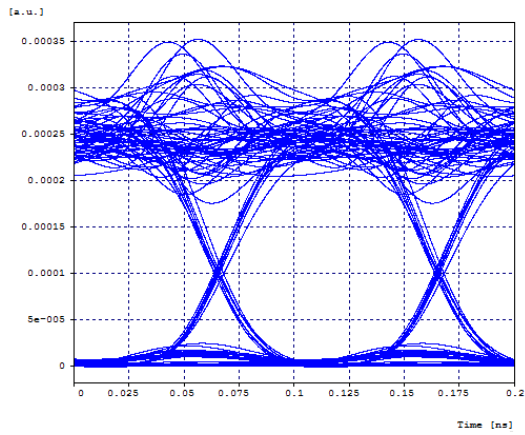
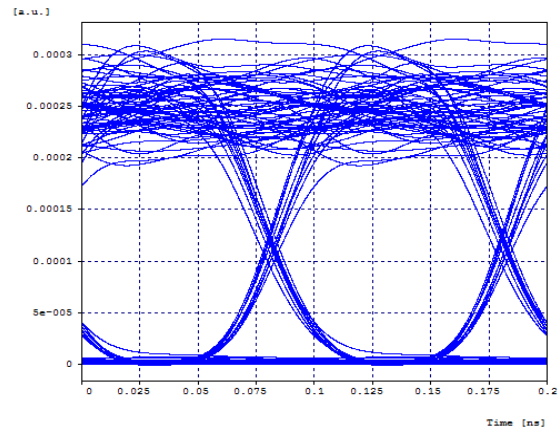

Figure 5.7: Q-factor v/s Distance



D=30km(a)



D=60km(b)

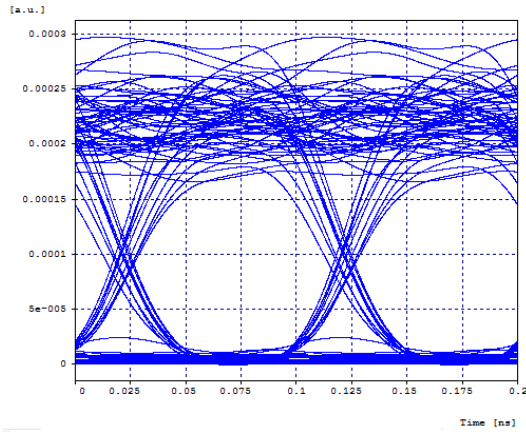

D=90km(c)

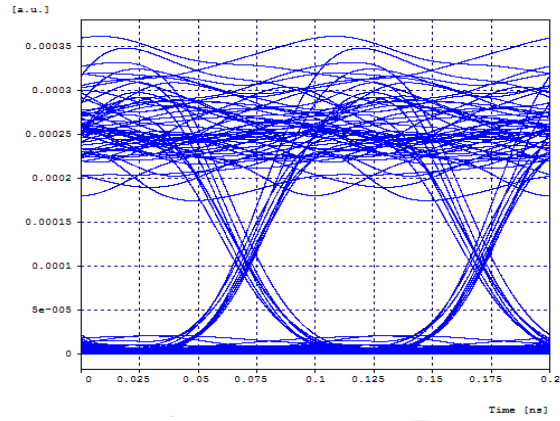

D=120km(d)

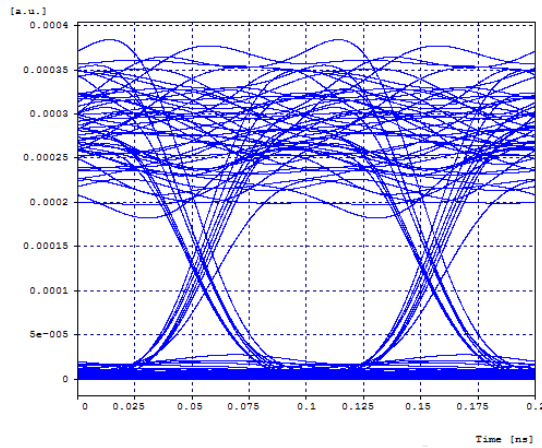

D=150km(e)

Figure 5.8: Eye diagrams for 50 GHz spacing

Figure 5.9 and figure 5.10 are the input and output power spectrum respectively. Here input spectrum is the spectrum before transmission through fiber. After transmission through fiber the spectrum at node 36 is shown in figure 5.10

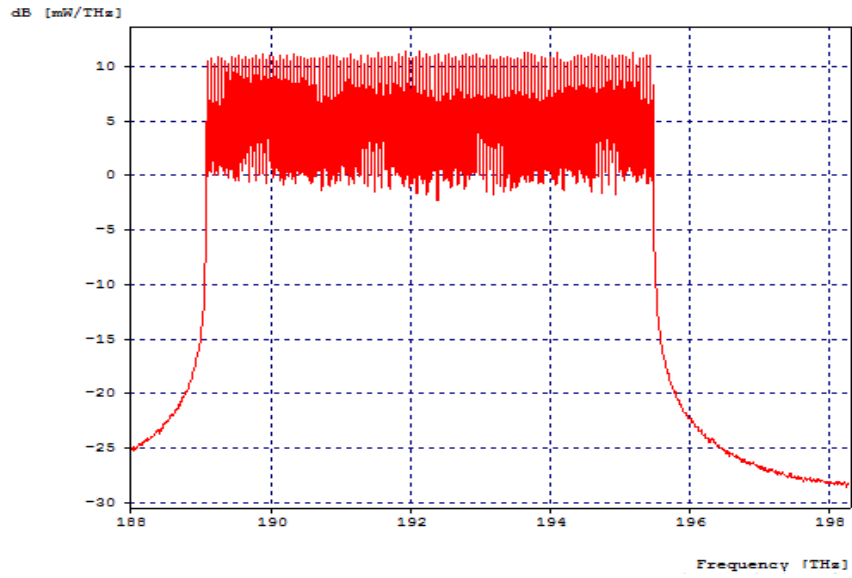

Figure 5.9: Input Power spectrum

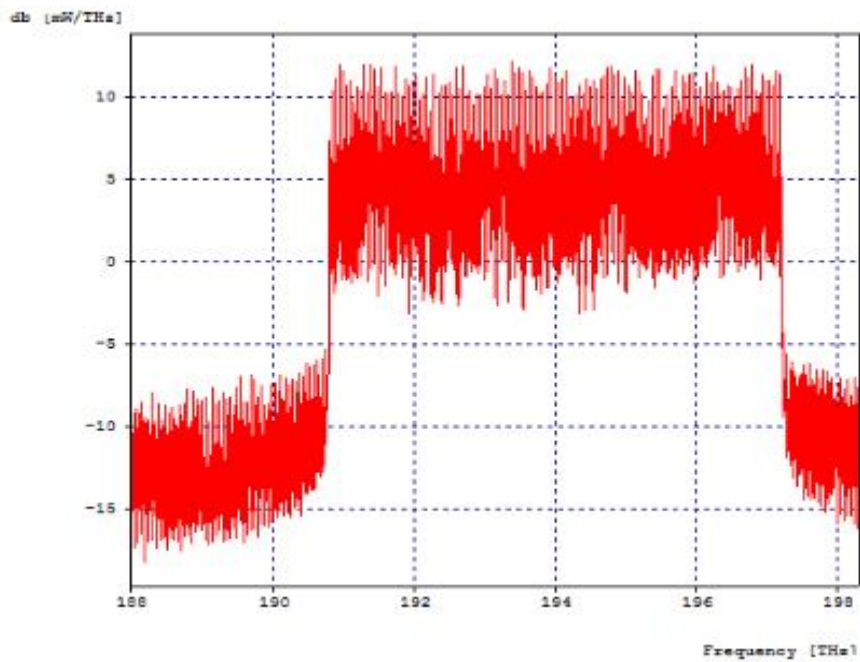

Figure 5.10: Output Power spectrum

Conclusion: The performance of 256 channel WDM system is analyzed at channel spacing of 25 GHz and 50 GHz. We analyze the output at channel of frequency 193.03 GHz. We take the output in the form of Quality factor at distance of 30 km to 150 km. it is seen that for

channel spacing of 25 GHz system cannot exist for distance greater to 140 km, because after 140 km the Q-factor for 25 GHz channel spacing is only 14.77 dB. But for channel spacing of 50 GHz system can exist because here Q-factor for distance 150 km is 15.66dB.

CHAPTER 6

CONCLUSION & FUTURE SCOPE

6.1 Conclusion

The first objective of thesis was to investigate the XPM effect on Q-factor, at different channel spacing. The performance analysis of cross phase modulation in optical communication system for 12.5 GHz and 10 GHz values of spacing has been done. It was found that spacing of 12.5 GHz has the higher Q-factor so better system performance. When we set increased gain value of EDFA's, the Quality factor was improved for both NRZ and RZ soliton transmission formats. RZ soliton has better performance than NRZ both at 200km. and at 3200km. XPM effect may reduce by increasing the channel separation. We conclude that RZ soliton is less affected to XPM so it is efficient transmission than NRZ format in 32 channel DWDM system

In this thesis, ring optical network has been demonstrated and analyzed at each node with bit rate of 2.5 Gbps, 5Gbps and 10 Gbps for different modulation formats like NRZ rectangular, NRZ raised cosine, RZ soliton, RZ super gaussian, RZ raised cosine and RZ rectangular. The distance between the nodes is set to 120km (SMF+DCF). Semiconductor optical amplifier after each node enhances the power level. The effect of insertion losses for a wide range of 40 dB to 100 dB is analyzed and it seen that RZ-soliton is performing better among all modulation driving schemes. It is seen that by using RZ soliton format system can exist up to 95 dB of insertion loss. The effect of OADM bandwidth is also analyzed and it is seen that after 10 GHz bandwidth there is huge rise in the system performances for NRZ rectangular and RZ soliton.

The performance of 256 channel WDM system is analyzed at channel spacing of 25 GHz and 50 GHz. We analyze the output at channel of frequency 193.03 GHz. We take the output in the form of Quality factor at distance of 30 km to 150 km. we seen that for channel spacing of 20 GHz system can not exist for distance of 150 km, because at 150 km the Q-factor for 25 GHz channel spacing is only 14.77 dB. But for channel spacing of 50 GHz system can exist because here Q-factor for distance 150 km is 15.66dB.

6.2 Future Scope

In this thesis, the work is limited to Cross phase modulation. The variation of bit error rate, Q factor, eye opening and output spectrums with Cross phase on changing various parameters like channel spacing, EDFA gain and transmitting formats have been considered. The effect of changing these parameters for self phase modulation, Four wave mixing i.e. other Kerr effects can be studied. Here we have studied ring network for 36 nodes with OADM and vary the bandwidth and insertion loss of the OADM. The other parameters of OADM can also be analyzed like crosstalk. On the other hand we can also use other device instead of OADM like OXC and can study the various parameters of the OXC. In this thesis we also investigate the performance of 256 WDM channel with channel spacing of 25 GHz and 50 GHz. so WDM system can also be analyzed with less channel spacing and a high speed switching element can also be used at channel to study the behavior of channel.

REFERENCES:

- [1] Tomoaki Ohtsuki and Iwao Sasase, "Optical Synchronous CDMA, Encyclopedia of Telecommunications" Editor: John Proakis, Wiley, 2002.
- [2] A.J. Mendez, R.M. Gagliardi, V.J. Hernandez, C.V. Bennett, and W. J. Lennon, "Design and Performance Analysis of Wavelength/Time (W/T) Matrix Codes For Optical CDMA", IEEE Journal of Light wave Technology, Volume 21, Number 11, Pages 2524-2533, November 2003.
- [3] Don Warren and Justin Moore, "Multiplexing in Fiber Optic Connections", Summer Ventures in Science and Mathematics, 2001.
- [4] G. P. Aggarwal, "Fiber-Optic Communication Systems", New York: Wiley Inter science, 2002
- [5] R. Ramaswami and K. N. Sivarajan, "Optical Networks: A Practical Perspective", New York: Morgan Kaufmann, 2001.
- [6] Biswanath Mukherjee, "Optical WDM Networks", Springer, New York, 2006
- [7] WWW.wikipedia.com
- [8] Rajneesh Randhawa et al., " optimum performance and analysis of Ring O networks", Optik-International Journal for Light and Electron Optics, Volume 120, Pages 934– 940, 2009.
- [9] Vinod Kumar et al., "Investigation on inter channel crosstalk at ADM for an optical ring network.", Optik-International Journal for Light and Electron Optics, Volume 121, Pages45– 49, 2011.
- [10] Carena, "A Time Domain Optical Transmission System Simulation Package Accounting for Nonlinear and Polarization-Related Effects in Fiber", IEEE Journal on Selected Areas in Communications, Volume 15, Number 4, Pages 751-765, 1997.
- [11] OptSim Technical Staff, "TDSS: Time Domain Spilt-Step Fiber Simulation Approach", White Paper of Artis Software Corporation, Turin, 1999.
- [12] OptSim User Manual, RSoft Design Group, Page. 6.
- [13] C. A. Brackett, "Dense wavelength division multiplexing networks: Principles and applications," IEEE Journal of Selected Areas Communications, Volume 8, Number 6, Pages 948-964, August 1990.

- [14] S.W.Bang, D.G.Daut, "Comparison between NRZ and soliton transmission with fiber nonlinearities in DWDM systems", International conference on wireless and optical communication networks, Pages 1-5, 2006.
- [15] S. W. Bang and D.G.Daut, "Analysis of CPM and FWM phenomena for various signaling formats in 16 channel DWDM", FIP international conference on internet, Proceedings of ICI05, September 2005.
- [17] N. Kikuchi, K. Sekine, and S. Sasaki, "Analysis of cross-phase modulation (XPM) effect on WDM transmission performance", Electronics Letter, Volume 33, Issue 8, Pages 653-654, April 1997.
- [16] Ajoy K. Ghatak, K. Thyagarajan, "Introduction to fiber optics", Cambridge University Press, June 1998
- [18] Nizar Bouabdallh, Andre-Luc Beylot, Guy Pujolle, "Efficient bandwidth sharing and fair access in single hub WDM rings ", Computer Networks Volume 50, Number 2, Pages 237-250, 2006.
- [19] Tim Gyselings, et al., "Crosstalk analysis of multi wavelength optical cross connects", Journal of Light wave Technology, Volume 17, Page 1273, 1999.
- [20] G.R Hill, et al., "A transport network layer based on optical network elements", Journal of Light Wave Technology, Volume 13, Pages 841-849, 1995.
- [22] Surinder singh, "Performance comparison of optical network Topologies in the presence of optimized semiconductor optical amplifier", Journal of optical and communication networks, Volume 1, Number 4, September 2009.
- [23] A. E. Willner and S. M. Hwan, "Transmission of many WDM channels through a cascade of EDFA's in long distance links and ring networks," Journal of Light wave Technology, Volume 13, Number 5, Pages 802-816, May 1995.
- [24] Rajneesh Randhawa et al., " Comparison of optical network topologies for wavelength division multiplexed transport networks ", Optik-International Journal for Light and Electron Optics, Volume 121, Pages 1096-1110, 2008
- [25] R.UI-Mustafa et al., "Grooming of non uniform traffic on unidirectional and bidirectional rings", Commut. Commun, Volume 29, Number 8, Pages 1065-1078, 2006.

- [26] G.V Chowdhary et al., "A cost effective approach for survivable multicast traffic grooming in bi directional multi wavelength ring networks", *Optical Switching Networking*, Volume 3, Number 2, Pages 89-103, 2006.
- [27] David Norte and Alan E. Willner, "All-Optical Data Format Conversions and Reconversions Between the Wavelength and Time Domains for Dynamically Reconfigurable WDM Networks", *IEEE Journal of Light wave Technology*, Volume 14, Number 6, Pages 1170-1182, June 1996
- [28] Ken-ichi Kitayama et al , "Dispersion Effects of FBG Filter and Optical SSB Filtering in DWDM Millimeter-Wave Fiber-Radio Systems" *IEEE Journal of Light wave Technology*, Volume 20, Number 8, Pages 1397-1407, August 2002
- [29] Hung Nguyen Tan et al. , "Reconfigurable All-Optical OTDM-to-WDM Conversion Using a Multiwavelength Ultrashort Pulse Source Based on Raman Compression" *IEEE Journal of Light wave Technology*, Volume 30, Number 6, Pages 853-863, March 2012
- [30] Alberto Aloisio et al., "Performance Analysis of a DWDM Optical Transmission System" *IEEE TRANSACTIONS ON NUCLEAR SCIENCE*., Volume 59, Number 2, Pages 251-255, April 2012
- [31] Jianqiang Li *et al.* , "Approaching Nyquist Limit in WDM Systems by Low-Complexity Receiver-Side Duobinary Shaping", *IEEE Journal of Light wave Technology*, Volume 30, Number 11, Pages 1664-1676, June 2012
- [32] S. Susskind and E. A. de Souza, "Transmission Limits Analysis of a 40 Channels DWDM System at 10 Gb/s Without Amplification, *IEEE LATIN AMERICA TRANSACTIONS*, Volume 9, Number 3, Pages 284-287, June 2011
- [33] Kawal Preet Singh et al., "Performance Analysis of different WDM systems", *International Journal of Engineering Science and Technology (IJEST)*
- [34] Nayla El Dahdah et al., "1-Tb/s DWDM Long-Haul Transmission Employing a Fiber Optical Parametric Amplifier", *IEEE PHOTONICS TECHNOLOGY LETTERS*., Volume 22, Number 15, Pages 1171-1173, August 2010
- [35] Gabriella Bosco *et al.* , "MLSE-Based DQPSK Transmission in 43 Gb/s DWDM Long-Haul Dispersion-Managed Optical Systems, *JOURNAL OF LIGHTWAVE TECHNOLOGY*.,, Volume 28, Number 10, Pages 1573-1581, May 2010

[36] Anamika and Vishnu Priye, "XPM Induced Crosstalk in Dispersion Compensated Fiber Links for DPSK and OOK Modulation Format" Electronics Engineering, Indian School of Mines.

[37] SUN Xue-ming, "Impact of polarization mode dispersion and nonlinear effect on 40 Gbit/s dense wavelength division multiplexing system", Front. Electr. Electron. Eng. China ,2006