

Reliable Energy Efficient Adaptive Routing Algorithm for Body Area Networks

*Thesis submitted in partial fulfillment of the requirements for the award of
degree of*

**Master of Engineering
in
Software Engineering**

Submitted By
Priya Juneja
(Roll No. 801331021)

Under the supervision of:
Dr. Sushma Jain
Assistant Professor



COMPUTER SCIENCE AND ENGINEERING DEPARTMENT

THAPAR UNIVERSITY

PATIALA – 147004

July 2015

ACKNOWLEDGEMENT CERTIFICATE

I hereby certify that the work which is being presented in the thesis entitled, "*Reliable Energy Efficient Adaptive Routing Algorithm for Body Area Networks*", in partial fulfillment of the requirements for the award of degree of Master of Engineering in *Software Engineering* submitted in Computer Science and Engineering Department of Thapar University, Patiala, is an authentic record of my own work carried out under the supervision of *Dr. Sushma Jain* and refers other researcher's work which are duly listed in the reference section.

The matter presented in the thesis has not been submitted for award of any other degree of this or any other University.

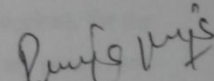

Signature:

(Priya Juneja)

This is to certify that the above statement made by the candidate is correct and true to the best of my knowledge.

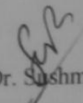

(Dr. Sushma Jain)
Assistant Professor,
CSED

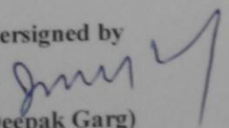
Countersigned by

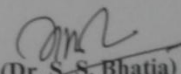
(Dr. Deepak Garg)
Head
Computer Science and Engineering Department
Thapar University
Patiala



(Dr. S. S. Bhatia)
Dean (Academic Affairs)
Thapar University
Patiala

ACKNOWLEDGEMENT

No volume of words is enough to express my gratitude towards my guide **Dr. Sushma Jain**, Department of Computer Science & Engineering, Thapar University, Patiala, who has been very concerned and has aided for all the materials essentials for the preparation of this thesis report. She has helped me to explore this vast topic in an organized manner and provided me all the ideas on how to work towards a research-oriented venture.

I am also thankful to **Dr. S.S. Bhatia**, Dean of Academic Affairs, **Dr. Deepak Garg**, Head of Computer Science & Engineering Department and **Dr. Damandeep Kaur**, P.G. Coordinator, for the motivation and inspiration that triggered me for the thesis work.

I would also like to thank the staff members and my colleagues who were always there at the need of hour and provided with all the help and facilities, which I required, for the completion of my thesis work. Most importantly, I would like to thank my parents and the almighty for showing me the right direction out of the blue, to help me stay calm in the oddest of the times and keep moving even at times when there was no hope.

ABSTRACT

Due to advancement in the telecommunication, wireless communication, wireless sensors, and other technologies a new field of research has been evolved and this area of research is termed as Wireless Body Area Networks. In WBAN miniaturized sensor nodes are implanted in the blood stream or on the human body. These sensor nodes are battery dependent, once the battery dies, node also dies. That's why minimum energy consumption with reliable data transmission is primary requirement in WBAN. To achieve minimum energy consumption there is a need of self-adaptive routing protocol. In this proposed work, a Reliable Energy Efficient Adaptive (REEA) Algorithm has been proposed which considers hop count, link quality and energy consumption for reliable route discovery Energy consumption is minimized in REEA by using the concept of piggyback scheme in which residual energy of different nodes are sent to their neighbors on demand and paths having nodes with low residual energy are skipped. REEA algorithm also uses a self- adaptive approach for even distribution of load in the communication network with minimum number of dead nodes and avoids energy-hole problem. The proposed approach has been applied on the real set data obtained from NICTA and simulated using the Castalia simulator. Obtained results of the proposed approach REEA are compared with AODV and LABILE routing algorithm on the basis of various metrics.

TABLE OF CONTENTS

	PgNo.
Certificate	i
Acknowledgement	ii
Abstract	iii
Table of Contents	iv-vi
List of Figures	Vii
List of Tables	viii
Chapter 1: Introduction	1-14
1.1 Body Area Networks	1
1.2 History of Body Area Networks	3
1.3 Difference between WSN and WBAN	3
1.4 Architecture of Body Area Networks	4
1.4.1 Intra-BAN Communication Tier-I	5
1.4.2 Inter-BAN Communication Tir-2	6
1.4.3 Beyond BAN Communication Tier-3	7
1.5 Applications of Body Area Networks	7
1.5.1 Medical Applications	7
1.5.2 Non-Medical Applications	9
1.6 Research Challenges	9
1.7 Routing Protocols for WBAN	13
1.8 Structure of the Thesis	14
Chapter 2: State of Art	15-21
2.1 Related Research	15
2.2 Routing in Body Area Networks	17

2.3 Current Research Projects on Body Area Networks	21
Chapter 3: Problem Statement	22-23
3.1 Barriers in the previous work	22
3.2 Problem Statement	23
3.3 Objectives of the proposed work	23
Chapter 4: Proposed Work	24-35
4.1 Architecture of Proposed Reliable Energy Efficient Adaptive Algorithm	24
4.1.1 Energy Estimator	24
4.1.2 Hop Count Estimator	25
4.1.3 Link Quality Estimator	25
4.1.4 Routing Table Generator	25
4.2 Implementation of Proposed Reliable Energy Efficient Adaptive Algorithm	26
4.2.1 Modules of Reliable Energy Efficient Adaptive Algorithm	28
4.2.2 Simulation Setup	26
4.3 Mathematical Model	33
4.4 Routing Algorithm for Proposed Reliable Energy Efficient Adaptive Algorithm	34
Chapter 5: Simulation Results	36-41
5.1 Simulation Parameters	36
5.2 Results	37
Chapter 6: Conclusion and Future Scope	42-43
6.1 Conclusion	42
6.2 Future Scope	42
Chapter 7: Reflective Diary	44-48

7.1 January, 2015	44
7.2 February, 2015	45
7.3 March, 2015	46
7.4 April, 2015	47
7.5 May, 2015	48
Chapter 8: Video Presentation	49
References	50-55
List of Publications	56

LIST OF FIGURES

Figure No.	Figure Name	PgNo.
Figure 1.1	Body Area Networks	1
Figure 1.2	Architecture of Body Area Networks	5
Figure 4.1	Architecture of Proposed Reliable Energy Efficient Adaptive Algorithm	24
Figure 4.2	Generic Route Discovery Method	26
Figure 4.3	General Node NED file in Castalia	27
Figure 4.4	Node Composite Module Structure	28
Figure 4.5	Flowchart for TunableMAC	29
Figure 4.6	Communication Module NED file	30
Figure 5.1	Running Simulations	38
Figure 5.2	Generated Castalia Output Files	38
Figure 5.3	Output File (without Temporal Variation)	38
Figure 5.4	Output file (with Temporal Variation)	39
Figure 5.5	Graph representing Packet Reception Ratio	39
Figure 5.6	Graph representing Energy nJ/bit	40
Figure 5.7	TunableMAC packet Breakdown (without temporal variations)	41
Figure 5.8	TunableMAC Packet Breakdown (with temporal variations)	41

LIST OF TABLES

Table No.	Table Name	PgNo.
Table 1.1	Types of Sensors	2
Table 1.3	Infrastructure Based Architecture vs. Adhoc Based Architecture	6
Table 1.2	Bit-Rate for different Applications	11
Table 1.4	Classification of Routing Protocols	14
Table 2.1	Different Routing Protocols	17
Table 4.1	RX Modes Parameters	32
Table 4.2	TX levels Parameters	32
Table 4.3	Delay Transition Matrix	33
Table 4.4	Power Transition Matrix	33
Table 5.1	Simulation Parameters	37

1. Introduction

1.1 Body Area Networks

Body Area Networks(BAN) is a network of miniaturized sensors and actuators which are low in cost, intelligent and can be placed on or implanted in-body(or even in blood stream) to get timely feedback for health monitoring, and for other applications[1]. BAN is composed of number of wireless nodes varies as per the required application. Nodes are the building blocks of WBAN, these heterogeneous nodes communicate with each other using different technologies like Bluetooth, Wi-Fi, ZigBee. Several nodes consist of different components: hardware unit, a processor unit, transmitter, transceiver, memory and battery. Nodes differ from each other according to their functionality or role in the networks. On a broad basis, these can be categorized as sensors, actuators and personal device as demonstrated in figure 1.1.

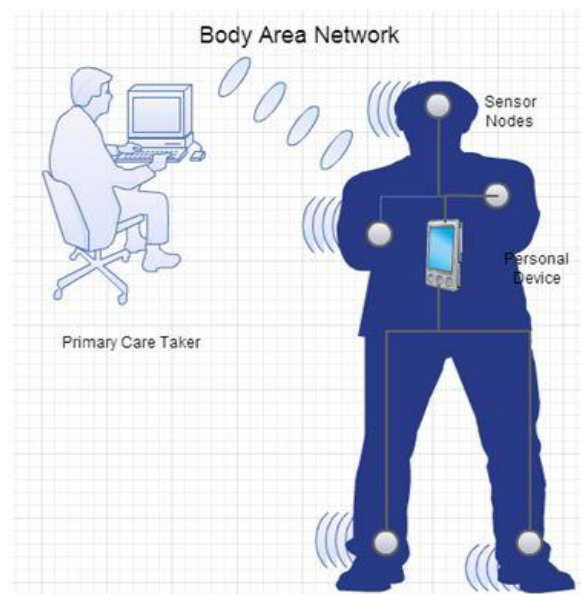

Figure 1.1 Body Area Networks

- **Sensor Node**

Sensor nodes sense the physical stimuli and responds in the form of digital or analog signals. The purpose of using sensors is to collect and process signals based on different parameters like physiological condition, temperature, blood pressure etc. Different types of commercially available sensors are categorized in table 1.1 with their functionality [2].

Table 1.1 Types of Sensors

Sensors	Topology	Functionality
Temperature Sensors	Star	Measure body temperature. Placed over the body.
Optical Sensors	P2P	As light passes from human body, its degree of absorption is measured and analyzed.
Electrochemical Sensors	Star	Measure particular chemical level e.g. Blood glucose sensor monitor glucose concentration in blood.
Bioelectrical Sensors	Star	Bioelectrical sensors measure electrical variations. e.g. ElectroMyoGraph (EMG) sensors measure electrical activity of nerves.
Motion Sensors	Star	Measure human motion based on different orientation. e.g. Accelerometers and Gyroscopes

- **Actuator Node**

Collected signals from the sensors are fed to the actuators. Role of actuator is to provide feedback as per the sensor's data. e.g. in automatic drug delivery system actuators automatically pump required dosage in the body after sensing the required level in the patient's body.

- **Personal Device**

Personal device is also termed as a sink, body gateway or a Body Control Unit (BCU). PD is termed as sink as its job is to collect data from the sensors and actuators and interact with the user whether it is patient or the doctor. Sometimes, smartphones are also used as a personal device.

Based on their placement, according to IEEE 802.15.6, these nodes are even given some special names like Implant node, Surface node, and External node. One more classification is coordinator, relay node, end node [3].

1.2 History of BAN

In the 90's , different groups at MIT (Massachusetts Institute of Technology) start working on wireless personal area network (WPAN) with the aim to communicate between various information devices which are attached to human body either on the body or implanted [3].These groups were intended to use electrostatic field communication technology for data communication and processing. In 2001, Zimmerman [4] presented how electronic devices implanted or on the body can communicate with each other using capacitive coupling picoamp currents. PAN standards do not satisfy the medical requirements for BAN. So, to overcome the shortcomings of IEEE 802.15.1 and 802.15.4, a committee was established in January 2006 named as Wireless Next Generation (WNG) which focuses on new topics on wireless technologies. Later on, IG-WBAN (interest group) was established in May 2006, which was approved as SG-WBAN, a study group. This study group was further certified as TG6 (Task group) in January 2008 under 802.15.In May 2008, all submitted applications to TG6 was compiled into a single document and a draft for BAN was approved in December 2011[3].

1.3 Difference between WSN and WBAN

The field of wireless body area networks has been evolved from the wireless sensor networks. But as bio-sensors in BAN are used in the proximity of our body so, there is large number of variations in the protocols, design techniques or in other features in Body Area Networks as compared to wireless sensor networks [1].

- **Node Placement**

In WSN, nodes are placed at different locations as per the requirement i.e. if these sensors are used for traffic monitoring then, nodes will be placed at different traffic lights etc. While in BAN, nodes are placed only in the proximity of a human body whether implanted in the blood cells or wore on the body as a wearable sensor.

- **Node Density**

Wireless Sensor Networks are node dense since, all nodes are not easily accessible. That's why to cope up with the adverse effects of node failures, redundant nodes are used. But in the case of Body Area Networks, nodes are

implanted in the proximity of a human body and they are easily accessible except the one implanted within the human body. That's why redundant nodes are not required.

- **Physical Access**

Nodes are not easily accessible in case of WSN because they may be placed at miles of km as per the requirement. In case of BAN, wearable nodes are easily accessible but not which are implanted within the body.

- **Security**

In case of WBAN, a highly reliable communication is required to ensure safe transmission of health data in case of health monitoring or in other applications. That's why uncompromising security protocols are required in case of WBAN.

- **Mobility**

Nodes are mobile in nature in WBAN due to human motion but in case of WSN nodes are static in nature.

- **Coverage**

Node coverage is in kilometres in WSN because data has to be sent from distant places while node coverage in BAN is in centimetres because data transmission is limited to human body.

- **Energy scavenging**

Energy scavenging in wireless sensor networks is done through solar and wind power while in BAN body heat, motion and other sources are used.

1.4 Architecture of Body Area Networks

Body Area Networks nodes communicate with each other through a number of wireless technologies like Zigbee, Bluetooth etc.

The architecture of BAN is divided into three tiers which consist of intra-body, inter-body and beyond WBAN communication. This system is composed of personal server and medical server. Different temperature sensors, electrochemical sensors, motion sensors, bioelectrical sensors collect data as per different parameters and send it using some wireless technology to the personal device which act as a coordinator node. Then, through wireless communication, this health related collected data is sent to the medical

server, which is controlled by a medical operator. The architecture of Body Area Networks is divided into three tiers as demonstrated in figure 1.2 [3].

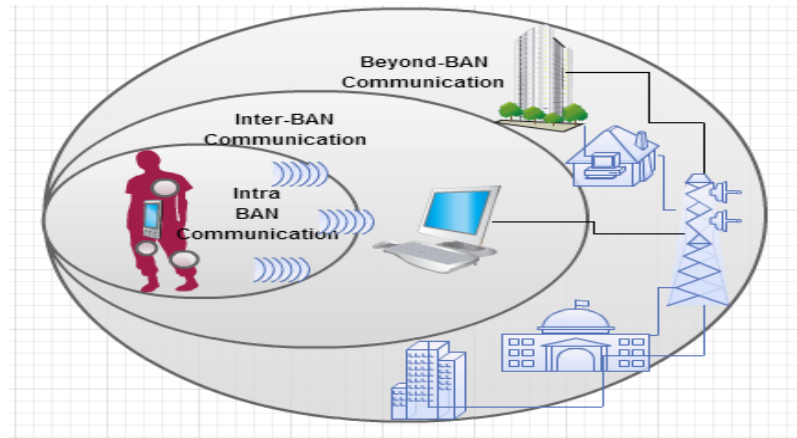

Figure 1.2 Architecture of Body Area Networks

1.4.1 Intra-BAN Communication Tier-1

Intra – BAN communication is tier-1 of the generalized architecture which corresponds to a) Communication between sensor nodes and b) communication between sensor nodes and personal device

Intra-BAN Communication is the communication within the tier-1. All the sensor nodes are implanted within the or on the body which collects data and sends it to the personal server within (~2 meters) transmission range. And then through some wireless technology via Wi-Fi, Bluetooth, ZigBee or other, the sampled data is passed to an access point in tier-2. Design of intra-BAN communication is little bit critical. To avoid number of energy and bit rate challenges, these low-battery sensors and PD can be directly connected to access point, wireless, wired or using different technique as per the application[2].

- Wired Connection between sensor and PD
- Direct Communication between sensors and AP(without PD)
- Wireless connection between sensor and PD(uses Star Topology)
- Wired or wireless connection between sensors and central processor:

Central processor further sends data to the personal device. By using central processor in between size of data to be transmitted to the PD is reduced by the central processor.

1.4.2 Inter-BAN Communication Tier-2

Inter – BAN communication is the communication between tier-1 PD and one or more access points. There is a gateway at the second tier and it acts as an interface between first and third tier to interconnect the WBAN sensors to the various networks so that they can be easily accessed in daily life. All the data passed to the third tier from 1st tier passes through this gateway. The AP’s can be considered as placed dynamically in tier-2 to handle some emergency conditions or can be the part of the infrastructure. On basis of the AP’s whether they are placed dynamically or they are the part of infrastructure, Inter-BAN communication can be divided into two paradigms.

- **Infrastructure Based Architecture**

Many of the projects of the BAN uses inter-BAN infrastructure based architecture like SMART [6] and CARENET [7] in order to avail the benefit of flexibility, centralized control and security management. The AP’s in Infrastructure based architecture can act as database server.

- **Adhoc Based Architecture**

In Adhoc based architecture, multiple AP’s form a mesh construction in order to transmit information to the medical service centres. Due to mesh topology, it allows better coverage as compared to infrastructure based architecture. This kind of communication architecture extends the communication range from two meters to one hundred meters approximately. Due to multi-hop dissemination in the mesh topology it also supports patient’s mobility.

Table 1.2 demonstrates the difference between Infrastructure based architecture and Adhoc based architecture.

Table 1.2 Infrastructure Based Architecture Vs. Adhoc Based Architecture

Infrastructure Based Architecture	Adhoc Based Architecture
Larger Bandwidth	Fast Deployment
Centralized Control	Encounter Dynamic environment
Flexibility	Supports Patient’s Mobility
Security Control	Better Service Coverage Area

1.4.3 Beyond-BAN Communication Tier-3

This tier-3 of Body Area Networks is application specific, all the data accessed from the tier-2 is then sent to the specific applications as per required. Beyond BAN communication can take communication level to one step further by extending it to the health care personnel in order to remotely access the medical data and after analyzing the data, act via sending Short Messaging Service (SMS) to the patient or via call or via some other medium. Tier-3 includes database, which is one of the major component in e-healthcare systems for record keeping of patient's data. This Beyond BAN Communication is developed for metropolitan area networks.

1.5 Applications of WBAN

The main objective of standardizing WBAN by IEEE is to enhance the standard of quality of life of human beings. And that's why WBAN is not only restricted to medical applications, it is not just medical-specific. As today, internet has changed the thinking of the common people, in the same way it is expected that WBAN will change the lifestyle of each and every person by the benefits of this technological advancement in maximum number of applications [3].

BAN applications are diverse as they are equally applicable in the medical field as well as non-medical field. One of the major health applications is remote health monitoring. In the past health monitoring is done through number of electrical equipment's but now due to integration of BAN nodes this electronic health monitoring has become mobile in nature because patient can be in motion while sensor nodes collects the health-related data. That's why eHealth has now been evolved to mHealth [8].

1.5.1 Medical Applications

Wearable Health Monitoring Systems (WHMS) are live examples of applications of BAN in the medical field [2].The sensors employed in these systems collects medical data of the patient and sends it to the external system using the conventional Wi-Fi technology. Medical applications require reduced bit-error rate and quality of service. That's why different algorithms are implemented at PHY and MAC layer to reduce this bit-error rate. Some medical applications are described below.

- **Sleep Staging**

Today there are thousands of people who are facing insomnia issues. It is scientifically proved that if you will not sleep properly, then it can affect your health too. But if some physician wants to monitor your sleep, then it will be quite difficult. Just imagine lots of wire going out through the head, it will be very difficult to sleep in this condition. WBAN sensors can make this analysis comfortable and easy, just some sensors will be there and no wires.

- **Military and Defence**

Network Enabled Capability (NEC) is a program running in our military and defence organization which uses advancement in information systems to achieve more effective military results. BAN sensors can be used both at an individual level for a soldier or for whole squad. At an individual level, soldier fatigue can be monitored using the different parameters like heart-beat and blood-pressure measures sent through the WBAN sensors which are worn by them.

- **Asthma**

Whether it is medical field or non-medical field, BAN brings realism after their deployment in real environment WBAN sensors provide real-time log of the presence of harmful substances in the air and then warns the user about the level of harmful particles present in the air. So, that asthmatic person will be alerted in advance and it can save lives of many people.

- **Cancer Detection**

Events which require pre-diagnosis like tumours and cancer causing cells can be detected using BAN sensors enabled with diffusion based molecular-communication. Due to diffusion based molecular-communication, it is possible to deal with this fatal situation for diagnosing and destroying cancer causing tumours [9].

- **Cardiovascular Diseases**

Cardiovascular diseases are the source of number of deaths each year worldwide. With the help of BAN in this field, this ratio can be decreased by a big amount just by analysing the waveforms of cardio-signals collected which provides better

patient monitoring and early detection of symptoms of diseases. Different WBAN sensors measuring different parameters have different bit-rate requirements as electrocardiogram, electroencephalogram (EEG), electromyogram requires bit-rate of approximately 192 kbps, 86.4 kbps, 1.56 Mbps respectively [10].

- **Diabetes Control**

Glucose-level monitor require bit rate of less than 1 kbps and automatic drug delivery requires a bit rate of approximately less than 16 kbps. WBAN enabled with diffusion based molecular communication can be used in developing automatic drug delivery systems , that is in case of diabetes this system will automatically analyse user's data based on different parameters collected and automatically give him required dosage in case of emergency.

1.5.2 Non-Medical Applications

Some of the non-medical applications of WBAN are as follows:

- Electronic bill payments
- In-car communication (automatically adjustable seats)
- Automatic operations (printer starts when you touch)
- Authentication (automatic opening and locking of door)
- Intelligent buildings
- Entertainment applications (in games)
- Emergency alarms
- Ambient assisted living
- Armature Sports training
- In wars to sense soldiers (whether alive or not)
- Body gesture recognition
- Emotion detection

1.6 Research Challenges

There are some issues which are needed to be dealt while using this new emerging technology. Some of these challenges are discussed below.

- **Environmental Challenges**

Signal Fading: Body Area Networks signals passes through a heterogeneous path when nodes are implanted inside the human body, that's why chances of path loss increases a lot due to absorption of energy. As the body is not static, it is in moving position, so if Body Area Networks nodes are implanted on the surface of the body, then still due to the movement of body chances of data loss increases. But still many techniques are proposed by many researchers to minimize this using multi-hop links as compared to single-hop links in case if data needs to travel a large number of meters.

Antenna Design: The other environmental challenge is an antenna design of Body Area Networks nodes. As there are a lot of movements in the body, so a lot of restrictions need to be faced during antennae design. The antenna design is directly related to the location at which it is implanted. These antennas require non-corrosive material but the challenge is that titanium and platinum are non-corrosive in nature but not as strong as compared to corrosive material. The proper trade-offs between size and efficiency is also considered during antenna design.

- **Security Challenges**

There is quite crucial data is sent over Body Area Networks. There are chances that an adversary can interfere in between this data sending and can change the data in between which may be harmful. For example, take the case when very confidential data related to heart disease is sent over the network and if someone changes this crucial data in between, and then it can prove to be life threatening for someone. So, there is need of secure management of data transfer using encryption and decryption, data integrity, data confidentiality, data authentication all needs to be managed at any cost. Shu-Di Bao uses biometrics scheme information as characteristics to secure Body Area Networks [5].

- **Transport Challenges**

During data transfer, quality of service must be maintained and this is the transport challenge which is mainly faced by Body Area Networks. BAN are used

mainly in real life applications, so these all applications are time-critical. So there must be a proper procedure for timely delivery of data with proper acknowledgement without any loss. These are some issues that tier-2 and tier-3 communication mainly faces in BAN communication.

Bit Rate: The Body Area Networks nodes use many technologies for variety of applications. All of them work on different frequency with different bit rates as demonstrated in Table 1.3. It ranges from 1 kbps to few mbps. So, different protocols whether they are error-corrective or for interference avoidance, they must be capable enough to handle this requirement.

TABLE 1.3: Bit-Rate for different Applications

	Application	Bit-Rate
Medical Applications	Glucose Level Monitor	<1 kbps
	Automatic Drug Delivery	<16 kbps
	EEG	86.4 kbps
	ECG	192 kbps
	Deep brain simulation	<320 kbps
Non-Medical Applications (Entertainment)	Audio Streaming	1 mbps
	Video Streaming	<10 mbps

Mainly BAN nodes communicate with in the proximity of a human body, so single hop topology like star topology is sufficient to implement. But sometimes there are chances of fading of signals due to some obstacles, so to decrease the attenuation in these radio signals multi-hop topology with proper mechanisms for relaying must be implemented.

- **Interoperability**

Wireless Body Area Networks based system sends seamless data using many technologies like Zigbee (IEEE 802.15.4), Bluetooth (IEEE 802.15.1), Wi-Fi (IEEE 802.11). But all these technologies differ from each other, all have

different requirements related to frequency bandwidth, data rate etc. This issue of interoperability must be handled.

- **Cost**

Wireless Body Area Networks is considered to be effective solution for health care problems. But in BAN, the nodes are miniaturized to the level such that the antenna and battery have to fit in compact case and then implanted. This miniaturization can be costly. So, there cost must be optimized to be affordable for all patients.

- **Consistent Performance**

Nodes in BAN can vary at different times in a single operation. So, there must be procedures implemented properly to deal with this association and disassociation of nodes for consistent performance. Wireless Body Area Networks works for life critical problems and all are time dependent. There is no scope of inconsistency it can be life threatening for someone. So, it is required that these systems must perform well consistently.

- **Interference**

There are chances that many people wearing the Body Area Networks sensors come in each other's range which can lead to collision and even the chances of packet loss increases. So, proper evaluation of the performance and the delay caused due to interference must be done. There must be a way so that nodes will recognize that they belong to which network so, that minimum interference will occur. Shu-Di Bao uses biometrics scheme information as characteristics to secure Body Area Networks. Poon *et al.* [5] uses principles of heart beat timing information for this purpose.

- **Battery Lifetime**

Frequent replacement of nodes must be avoided especially when nodes are implanted within the human body because they are not easily accessible. And this is only possible if nodes are equipped with long battery life. So, proper energy efficient solutions must be implemented in order to study the impact of battery lifetime and power consumption. Energy scavenging options can also be implemented using body-heat or body-movements to recharge the dead batteries.

1.7 Routing Protocols in Body Area Networks

Communication in the wireless body area networks depends upon routing protocol. Each node after sensing data routes the packet according to the routing protocol implemented. But developing routing protocol for the wireless body area networks is a challenging task due to following challenges [3-11].

- **Body Mobility & Network Topology Partition**

Different postural movements like sitting, standing, walking, running or other posture causes dynamism in the human body and in response to it network topology connections changes or may disconnects. Sometimes body clothing even become the reason for signal blockage and fading. That's why proposed routing protocol should deal with these signal attenuation issues.

- **Body temperature**

Overheating of nodes may result in rising body temperature which can harm body tissues. So the proposed routing protocol must be temperature sensitive and it should keep the node temperature below the danger level in order to minimise signal interference and avoid tissue damage.

- **Energy Consumption & Network lifetime**

In the medical WBANs, there are number of sensor nodes implanted on or in the blood stream of the patient. Frequent replacement of nodes must be avoided especially when nodes are implanted within the human body because they are not easily accessible. And this is only possible if nodes are equipped with long battery life and network depletion time is as low as possible. That's why routing protocols require reliability, increased network lifetime and reduced energy-consumption for prolong use [12].

- **Limited Hop Count**

Increased number of hops will surely leads to increased energy consumption. So, hop count threshold must be considered during proposing any routing protocol.

Table 1.4 demonstrates the classification of routing protocols on the basis of different parameters.

Table 1.4 Classification of Routing Protocols

Basis of Classification	Classification
Network Administration	1. Static Routing protocol : Fixed Routing table 2. Dynamic Routing Protocol: Regularly updated Routing Table
Network Dimension	1. Interior protocol : For single routing networks 2. Exterior Protocol : For different routing networks
Data Transmission	1. Single Hop Routing : Direct communication between source and sink node 2. Multi Hop Routing : Relay nodes are used
Network Topology	1.Flat Routing protocol 2.Hierarchical Routing Protocol 3.Location aware Routing protocol

1.8 Structure of Thesis

The thesis is structured in six chapters in the following way:

Chapter 1 gives the introduction about the body area networks and discussed how they evolve from wireless sensor networks. This chapter also highlights the architecture, applications, research challenges and routing protocols for wireless body area networks.

Chapter 2 discusses the state of art which involves the research areas of body area networks and discussed in detail about the network layer and wide number of routing protocols for body area networks. This chapter also discussed about the number of research projects working in the field of body area networks. Chapter 3 illustrates the problem statement and objectives of the proposed work. Chapter 4 gives the insight knowledge of the proposed work in detail and depicts how link quality, hop count and residual energy can help in designing a Reliable Energy Efficient Adaptive algorithm.

Chapter 5 discusses the simulation parameters and compares the result obtained from the new proposed routing approach with the existing approaches. Chapter 6 discusses about the conclusion, limitations of proposed work and its future scope.

2.1 Related Research

Body Area Networks is a network of sensor nodes implanted within the blood stream or on the body. Different available sensor nodes have different functionality. The idea of BAN comes from MIT, when different groups at MIT started working with the aim to develop something which can communicate between devices implanted on the human body. With this idea, they come to the fact that electronic devices can communicate through capacitive coupling and eventually Body Area Networks is developed. BAN can be used for both medical and non-medical applications. In case, of medical applications security is a major issue. After some research, it was shown that biometrics scheme can be used to secure BAN communication. To avail security management, some live projects of BAN like SMART and CARENET uses inter-BAN infrastructure based architecture. Due to implanted nodes, BAN nodes even communicate when a person is not static. That's why due to the concept of BAN eHealth has now been evolved to mHealth. Information obtained from BAN sensors can be used to deal with many fatal medical conditions like to diagnose and destroy cancer tumours. Different BAN sensors have different bit-rate as per the requirements. BAN have many requirements but their development is quite challenging [1-11].

Body Area Networks(BAN), this term has been first coined by Dam *et al.* [13].From the day of standardization of BAN, there are lot of researches has been done by different experimenters related to architecture, network lifetime, topology, routing, security and other terms related to body area networks .

General communication architecture for wireless sensor nodes in a Body Area Networks is suggested by Otto *et al.* [12] for health monitoring. In this paper, maximum number of nodes are stated 20 in wireless body area networks but generally they also suggested that number of nodes are not limited. Zasowski, *et al.* [14] conducted some experiments and concluded that maximum number of nodes can be 50 in order to serve 50 orthogonal channels. Various factors affect the reliable communication in the proximity of body in Body Area Networks and network lifetime is one of them. Tachtatzis *et al.* [15] investigated the lifetime of Body Area Network sensor nodes with the help of various

models proposed by IEEE and concluded the importance of either one hop or star topology for medical application of these low power devices with network lifetime.

In the case of network communication in Body Area Networks, mainly research area are design factors, network topology, communication protocol, channel characteristics and channel access control.

- **Design Factors:** Design aspect for BAN sensor nodes should be seriously considered because nodes are very small in size and their miniaturized size affects transmission range and energy consumption. Benny *et al.*[16]worked in this field and designed a sensor node which is of only 92 mm. Due to miniaturized nodes transmission range even become smaller like Esko *et al.* [17] has used ultra-low range transmission of 0.2-1 and 0.2 m.
- **Network Topology:** Network architecture i.e. whether communication topology is single hop or multi hop can also affect the overall performance of any wireless sensor network. Silva *et al.* [18] investigated star network and multi hop network approach based on different parameters for the Body Area Networks like energy consumption, transmission delay, and interference.
- **Physical Layer**

Physical layer of BAN architecture is responsible for signals decoding and coding, bit transmission, generating preamble and specifying media of transmission (i.e. channel selection and channel characterization).

➤ **Channel Characterization**

Fabio *et al.* [19] has analysed number of channel characteristics by measuring narrow band transmission channel. These channel characteristics includes attenuation at small and large scale, path losses due to movement and environment.

Aoyagi *et al.* [20] has used simulation based method for measuring channel characteristics. Leap Frog algorithm is employed in it during simulation of signal transmission.

Reusens *et al.* [21] demonstrated combination of actual measurement and simulation for energy measurement in single and multi-hop network. A path loss model is also depicted.

- **MAC Layer**

Sana *et al.* [22] analysed CSMA/CA protocol and concluded that in case of high traffic on nodes, this protocol have to face very dangerous collision issues. Otal *et al.* [23] have proposed DQMAC Distributed Queuing MAC protocol and results shows that this protocol improves network efficiency. Tan *et al.* [24] have proposed HMAC protocol is which is TDMA based and uses heart-beat rhythm information for synchronization and energy efficiency. Marinkovic *et al.* [25] have proposed WhMAC protocol which is also TDMA based and have low power utilization. Fang *et al.* [26] have proposed BodyMAC protocol which is used to realise the energy efficiency by decreasing radio transmission and controlling packet overhead.

2.2 Routing in Body Area Networks

Table 2.1 will give the overview of routing protocols available for body area networks:

Table 2.1 Different Routing Protocols

Routing Protocol	Example
Cluster-based Routing Protocol	Routing of data is done through heads of different node clusters. 1. Anybody: Watteyne <i>et al.</i> [27] have proposed this self-organizing protocol. In this protocol, step by step routing is done through neighbor discovery, density calculation, contact cluster head, set up backbone and routing path. 2. HIT: Culpepper <i>et al.</i> [28-29] have proposed Hybrid Indirect Transmission, a cluster based routing algorithm. It uses multi-hop parallel transmission within and among clusters. Analysis shows that HIT have smaller energy consumption, high network lifetime with smaller delay.
Probabilistic Routing Protocol	Link state information is used to update cost function periodically and route paths are chosen by minimizing cost function.

	<p>1. ETPA: Movassaghi <i>et al.</i> [30] have proposed Energy Efficient Thermal and Power Aware Routing in which cost function depends upon adjacent nodes received power, temperature of nodes and energy level.</p> <p>2. PRPLC: Quwaider <i>et al.</i> [31] have developed Probabilistic Routing with Postural Link Costs. In this protocol, link likelihood factor is used as a cost function where $L_{i,j}$ denotes probability of connecting link i and j in some time slot .</p> <p>3. DVRPLC: Quwaider <i>et al.</i> [32] have proposed Distance Vector Routing with Postural Link Costs. This protocol specifies a cumulative link cost factor for cost of routing over a link in some time slot.</p> <p>4. OBSFR: Quwaider <i>et al.</i>[33] have proposed On-Body Store and Forward Routing, In this protocol, network partitioning is avoided in a way that if one node gets a packet then it will store it until it find node which is listed in node ids (path form source to destination) of the packet.</p>
<p>Cross-Layer Routing Protocol</p>	<p>Combines network and MAC layer challenges in order to achieve low energy-consumption, increased throughput but still performance is low due to body mobility and path loss.</p> <p>1. WASP: Ruzzelli <i>et al.</i> [34] have proposed Wireless Autonomous Spanning Tree Protocol. In this protocol, spanning tree is set up and time slot is divided into WASP cycles. Routing and media access control is provided using same spanning tree. It does not consider mobility, link quality and 2-way communication.</p> <p>2. CICADA: Braem <i>et al.</i> [35] have proposed Controlling Access with Distributed Slot Assignment Protocol. It includes 2-way communication and improves reliability by considering multi-hop TDMA scheduling.</p>

	<p>3. TICOSS: Ruzzelli <i>et al.</i> [36] have proposed TimeZone Coordinated Sleeping Mechanism. Features of TICOSS are time zoning, shortest path based routing, save energy through V-scheduling.</p> <p>4. BIOCOMM: Bassiouni <i>et al.</i> [37] have proposed Cross Layer MAC and Routing Protocol Co-Design for Biomedical Sensor Networks. Features of BIOCOMM are hop-count strategy routing, less energy consumption, reduced temperature rise.</p> <p>5. AMR: Ababneh <i>et al.</i> [38] have proposed Adaptive Multi-Hop Tree Based Routing, It uses spanning tree strategy in conjunction with RSSI(Received Signal Strength Indicator), battery consumption and hops to achieve balanced energy consumption.</p>
Temperature based Routing	<p>Node temperature is considered as routing metric to avoid tissue damage due to overheating of sensor nodes.</p> <p>1. TARA: Tang. <i>et al.</i> [39] have proposed Thermal Aware Routing Algorithm which follows withdrawal strategy in order to route packets from low temperature paths and reroutes from high temperature areas.</p> <p>2. LTR: Least Temperature Routing, Bag <i>et al.</i> [40] have proposed temperature based LTR routing algorithm. The concept behind LTR is that always least temperature node is chosen for next hop. Nodes with high temperature are termed as hot spots.</p> <p>3. ALTR: Bag <i>et al.</i> [40] have proposed Adaptive Least Temperature Routing. In this protocol, irrelevant loops are not considered and least temperature with least hop count is considered as routing metric.</p> <p>4. LTRT: Takahashi <i>et al.</i> [41] have proposed Least Total Route Temperature algorithm which uses dijkstra algorithm along with nodes weights measured in temperature.</p>

	<p>5. HPR: Bassiouni <i>et al.</i> [42] have proposed Hotspot Preventing Routing. In this protocol, minimum number of hops with no hotspot formation is taken as a routing metric.</p> <p>6. RAIN: Bassiouni <i>et al.</i> [43] have proposed routing algorithm for networks of homogenous and Id-less biomedical sensor nodes, In addition to hotspot prevention, RAIN is fault tolerant and even works properly if some node dies due to energy depletion.</p> <p>7. TSHR: Ahourai <i>et al.</i> [44] have proposed Thermal Aware Shortest Hop Routing. This algorithm is required if some applications require high prioritized delivery of packets to destination.</p>
QoS-based Routing	<p>To achieve different QoS based objectives modular approach is used. Different modules are related to efficient power, reliability, delay and neighbor information.</p> <p>1. LOCALMOR: Djenouri <i>et al.</i>[45] have proposed LOCALMOR algorithm for biomedical sensor applications. Apart from different QOS metrics, scalability is not measured through this algorithm.</p> <p>2. DMQoS: Razzaque <i>et al.</i> [46] have proposed DMQoS, a data centric multi objective QoS aware routing protocol which provides customized QoS services according to different type of traffic generated.</p> <p>3. RL-QRP: Liang <i>et al.</i> [47] have proposed Reinforcement Learning based Routing Protocol with QoS support. In this protocol, concept of geographic location is considered for routing. All the nodes individually implement reinforcement learning algorithm for selection of routes.</p>

2.3 Recent Projects on Body Area Networks

During the last 10 years, there has been number of research is going on and number of projects have been developed till now [3]. MobiHealth is a funded project of the European Commission which was started in May 2002 and completed in February 2004. As the name suggests it has developed a health monitoring system by allowing patients to be mobile. Intra-body communication is done through Bluetooth, inter body communication through Zigbee/Bluetooth and Beyond BAN communication through GPRS in this system. Sensors are used for ECG, heart rate and blood pressure. WiMoCA is one of the existing projects on wireless Body Area Networks. Target application for WiMoCA is gesture detection using wearable sensors. For Intra-BAN communication, it uses star topology and for Inter-BAN communication Bluetooth is used and for beyond BAN communication Wi-Fi, internet, cellular network or Bluetooth can be used. MIMOSA is a European project which stands for “Microsystems platform for Mobile Services and Applications”. Many partners are working on it with a concept to make ambient technology a reality. It uses Bluetooth/Wibree for Intra-BAN communication, GPRS for Inter-BAN communication and internet for Beyond BAN communication. HealthServices24 project is developed with the collaboration of many specialists with expertise in their own field like wireless communication, medical industry etc. HealthServices24 is developed with the concept of mobile health care in order to make human lives easier and decrease health costs. This project surely works for mankind’s benefit. It uses wired connection for intra body communication, GPRS for inter and beyond BAN communication. ASNET (Adhoc Sensor Network) is developed for remote health monitoring. It allows in tracking the patient’s data whether the patient is inside or outside hospital. It uses wired or wireless interface for Intra Body Area Networks communication and Wi-Fi or Ethernet for Inter Body Area Networks communication and internet for beyond Body Area Networks communication. CareNet project is developed for remote healthcare with the concept of two tier communication. It provides reliable human medical data for analysis. It uses Zigbee for inter body area communication and internet for beyond Body Area Networks communication.

3. Problem Statement

3.1 Barriers in the Previous work

Varied characteristics of Body Area Networks has raised number of issues which are necessary to consider during designing efficient routing protocol. Among all of these issues, major challenge of a routing protocol is to provide quality of service (QoS) data transmission with limited resources and low power links. A routing protocol also requires a self-adaptive routing strategy to find multi paths (if some node becomes dead) with high network lifetime, minimum energy consumption, high packet reception ratio and minimum delay. In the context of routing protocols for Body Area Network minimum energy consumption is one of the critical issue because sensor nodes are implanted on the body or within the blood stream and frequent replacement of these batteries is not possible. Routing protocol should also focus on minimizing signal fading because signal fading results in more energy consumption overhead, lower packet reception ratio and increased delay. One another import issue to deal with is hot-spot or energy hole problem. In the hot-spot problem, nodes which are closer to base station are used in most paths which leads to early use of their energy resources. Due to this, path from various nodes to the base station get disconnected and packet loss increases.

Till now, mostly proposed routing algorithm for Body Area Networks works on the basis of Adhoc On-Demand Distance Vector protocol (AODV). AODV protocol was originally proposed in RFC 3965. AODV works on the concept of demand based routing. This protocol uses Route-Request (RREQ) packets, route request flooding only when the source wants to send data to some sink with no known route. The two steps performed in AODV are route discovery and route maintenance. One of the disadvantages of AODV is that sometimes sensor nodes may experience a large delay in route discovery and construction and more bandwidth is consumed. In AODV, routing is mainly done only on the basis of minimum hop-count. But sometimes path with minimum hop-count is not energy efficient and choosing this path for routing causes more energy consumption. Energy-hole problem also exists in AODV as there is no support for minimum energy consumption.

Link quality based algorithms searches routes based on link quality indicator (LQI) which is measured with the help of received signal strength (RSSI). Link quality based algorithm defines a LQI threshold with the help of many experiments performed and then categorizes the links into good or bad. During path discovery, always weak links are rejected and good links are chosen which leads to premature death of good link nodes and the network becomes dead soon. In this way, Link based routing algorithm also lacks major important factor i.e. minimum energy consumption.

3.2 Problem Statement

Major challenging area in the field of Body Area Network is reliable communication over multiple paths with minimum energy consumption. Thus, a Reliable Energy Efficient Adaptive (REEA) Algorithm has been proposed which considers hop count, link quality and energy consumption for reliable route discovery. In REEA algorithm, energy consumption is minimized by using the concept of piggyback scheme in which residual energy of different nodes are sent to their neighbors on demand and paths having nodes with low residual energy are skipped.

The Reliable Energy Efficient Adaptive Algorithm (REEA) is also designed to deal with energy-hole problem. It stores multiple paths from source to destination, and path with optimum energy level is chosen. Additionally, REEA algorithm uses a self- adaptive approach for even distribution of load in the communication network with minimum number of dead nodes.

3.3 Objectives of the Proposed Work

Objectives of proposed methodology are as follows:

- To build an optimized (Minimum energy consumption and maximum network lifetime) routing algorithm for BAN by considering some major metrics i.e. hop-count, residual energy and link quality for route discovery.
- To build a self-adaptive routing algorithm i.e. which stores multiple paths for a single source to destination so that if some node becomes dead then it routes packet from different path.
- To eliminate the hot-spot or energy hole problem in the routing algorithm.

4.1 Architecture of Proposed Reliable Energy Efficient Adaptive Algorithm

Proposed routing algorithm routes packets on the basis of hop count estimation, residual energy and weak links estimation. It is an extension of AODV and link quality based routing algorithm. Additionally it also includes a self-adaptive scheme for network load balancing and avoids the energy hole or hot spot problem. Figure 4.1 demonstrates the components of reliable energy efficient adaptive algorithm.

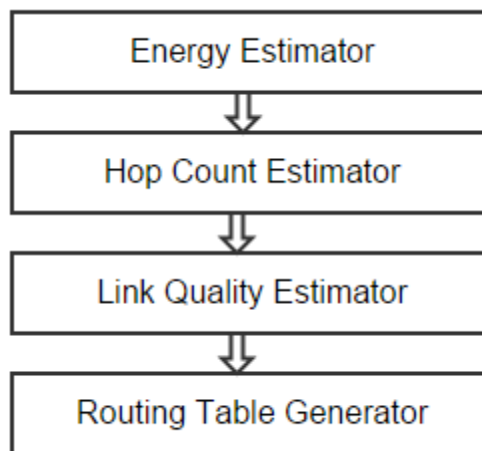

Figure 4.1 Architecture of Reliable Energy Efficient Adaptive Algorithm

4.1.1 Energy Estimator

Main objective of proposing REEA algorithm is energy efficient routing to avoid premature death of sensor nodes. That's why in order to extend AODV algorithm, energy estimation module is added for routing. In Energy Estimation module, a special Energy Advisor (EADV) message is used in order to estimate the residual energy of nodes. There are two components of EADV message i) Source MAC address and ii) Changed Energy Level. EADV message alerts all the neighbors about the current residual energy of the sensor node. Threshold Energy level (TE_{th}) is defined according to result of number of experiments conducted by NICTA [48]. Each node stores its own energy level and after t

time units it compares its energy level with previous one and if difference is greater than the threshold value then, it shows requirement of recharging battery. If there is no recharging source, then node is stated as dead and the corresponding message is sent to neighbors.

4.1.2 Hop Count Estimator

AODV algorithm works on the basis of only hop count. Path having the lesser number of hop counts is chosen for data delivery. But REEA algorithm doesn't depend only upon hop-count. It has three main key metrics hop-count, residual energy, link quality. In case of hop-count, a hop-count threshold level (TH_{th}) is defined which depends upon the network size [48]. The hop-count threshold value is used to determine maximum number of hops that are allowed in a path from source to destination. There may be cases when route A has more number of hop-count but lesser energy consumption and route B has less number of hop count but more energy consumption. In this case, hop-count threshold plays an important role for route discovery. Hop-count of route B is compared with TH_{th} and if it is smaller than TH_{th} then route B is chosen otherwise route A.

4.1.3 Link Quality Estimator

Link quality estimation is also an important metric for route estimation. Link quality is measured with the help of two metric i.e. Received signal strength and Signal to noise ratio. The link quality value ranges from 0 to 255 and according to this range, links are categorized as 0 (worst) and 255 (best). A link quality threshold, TLQ_{th} value is also chosen on the basis of experiments conducted by NICTA [48] . The links having value less than TLQ_{th} are termed as positive links and having value more than TLQ_{th} are termed as negative links. During routing path discovery all the paths are tested and number of negative links counter is generated. After receiving each RREQ (Route Request) message and RREP (Route Reply) message, link quality is updated with each hop count. After updating it is compared with TLQ_{th} and negative links counter is also updated.

4.1.4 Routing Table Generator

Routing table generator works by combining three factors hop count, link quality and residual energy. Routing table of each node contains this information hop count from

source to destination, next hop MAC address, destination MAC address, negative links counter and next hop residual energy. According to the REEA routing algorithm, routing is prioritized on the basis of maximum residual energy with good link quality and at least hop count less than or equal to TH_{th} . Figure 4.2 demonstrates the generic route discovery method. As shown in the figure 4.2, S is source and D is destination. There are two paths from source to destination path A and path B. First of all, it seems that path A must be chosen as there are less number of hops, but if we compare the number of negative links, then there are more negative links in path A. So, if hop count of path B is less than threshold hop count, then path B is chosen for routing.

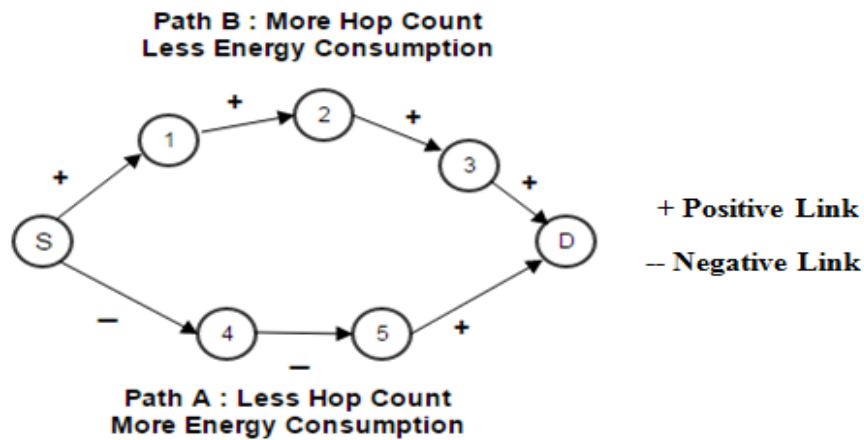

Figure 4.2 Generic Route Discovery Method

4.2 Implementation of Proposed Reliable Energy Efficient Adaptive Algorithm

Proposed Reliable Energy Efficient Adaptive algorithm is implemented in Castalia 3.3. It is an OMNET++ based body area networks simulator majorly used for low-power devices simulation. OMNET++ is an OOPS based framework for modelling discrete event network models. OMNET++ tool is written in C++ and this tool uses Eclipse as an IDE (Integrated Development Environment).

4.2.1 Modules of Reliable Energy Efficient Adaptive Algorithm

In Reliable Energy Efficient Adaptive algorithm each node is composed of following modules. Figure 4.4 demonstrates the general node composite module structure.

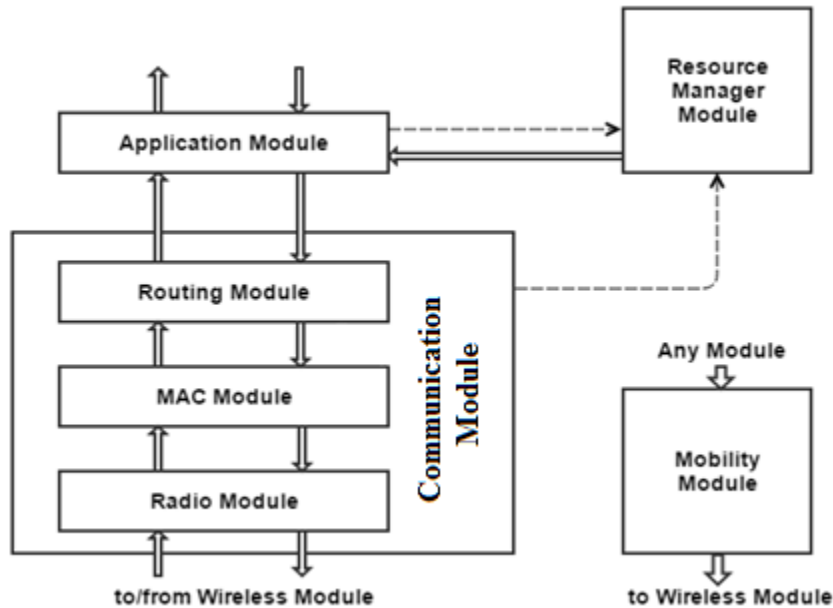

Figure 4.4 Node Composite Module Structure

- **Wireless Module**

Wireless Module is one of the important modules in implementing REEA algorithm. Wireless module provides a realistic simulation environment with the help of realistic path loss models and temporal variations. The main three aspects of wireless module are path loss model, node mobility and temporal variation.

- **Application Module**

Using application module of Castalia, new applications are designed for different requirements. Various parameters like packet size, packet rate etc. can be set here.

- **Communication Module**

Communication Module is further divided into Routing Module, MAC Module and Radio Module.

➤ **Routing Module**

Routing Module generates a routing table on the basis of hop-count, residual energy and positive links and decides the packet transmission paths.

➤ **MAC Module**

MAC Module plays an important role in Castalia. There are different MAC procedures are implemented within the Castalia and one of them is CSMA/CA. In Reliable Energy Efficient Adaptive Algorithm, simple CSMA/CA (TunableMAC) protocol is used.

Figure 4.5 demonstrates the general working of TunableMAC protocol.

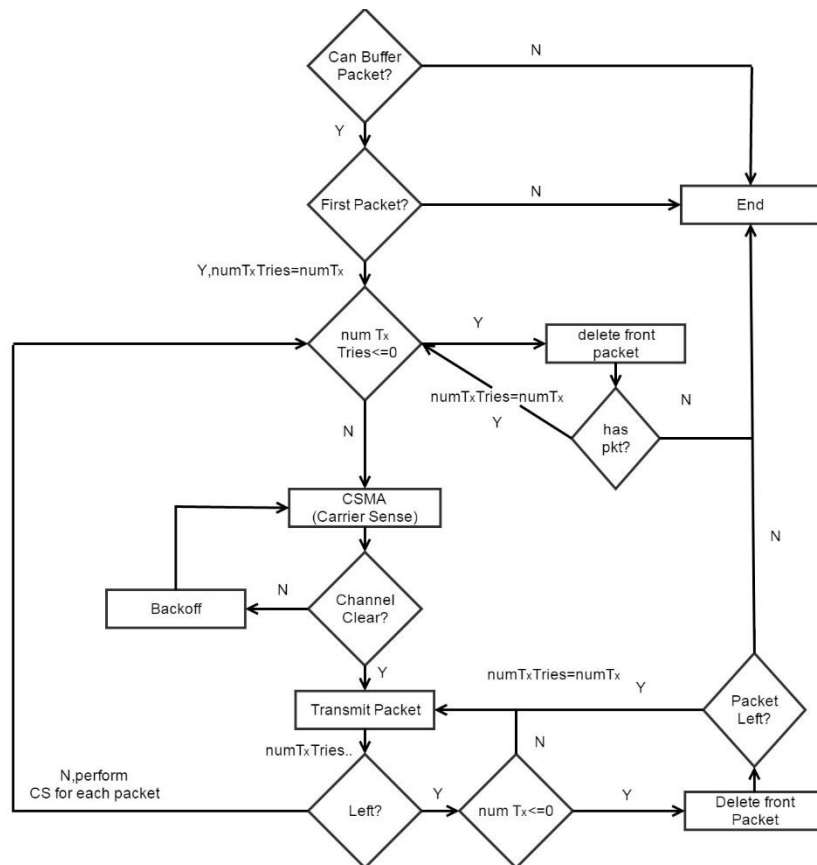

Figure 4.5 FlowChart for TunbaleMAC

Here numTx = Number of copies of packets sent by MAC layer

➤ **Radio Module**

This module contains many important features of low power devices like multiple states a) TX (transmit) b) RX(Receive), Different power levels,

Modulation schemes(already a part of Castalia) , continuous RSSI measurement, power consumption of all the states, Channel Clear Assessment (CCA) capability. .

Figure 4.6 illustrates the communication module network interface descriptor file.

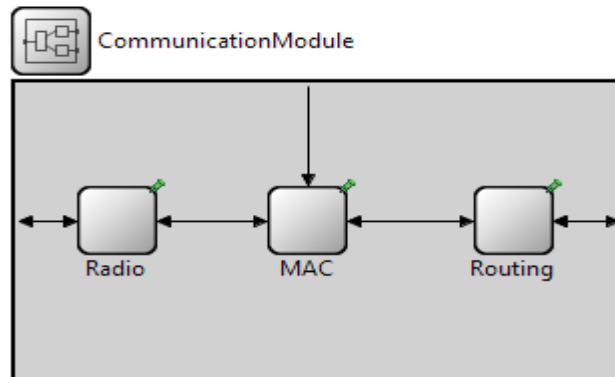

Figure 4.6 Commumication Module NED file

- **Resource Manager Module**

Resource Manager Module keeps all the information about the energy resources. It also helps in calculating the energy spent by each node and updates their residual energy periodically.

- **Mobility Module**

Nodes can be mobile in the case of Body Area Networks. Mobility Module allows the mobile nature of nodes. It holds the location of all the nodes and notifies about the periodical change in their location.

4.2.2 Simulation Setup

Various simulation setup parameters are described below:

- **Environment**

Simulation is carried out using Castalia 3.3 which is a realistic Body Area Networks simulator.

- **Location of Nodes**

6 nodes are implanted on the human body as follows:

Node 0 - Right Hip Node 1 - Left Wrist Node 2 - Right Wrist

Node 3 - Left Ankle Node 4 - Right Ankle Node 5 – Chest

- **Parameters**

Simulation Time Limit , Number of nodes , Path loss File , Temporal Model parameter file , Power Levels , Application packet Rate , Application Packet Size, Maximum Frame Retries , TE_{th} (Threshold Energy Level) , TH_{th} (Threshold Hop Count) , TLQ_{th} (Threshold Link Quality).

- **Body Postures for Experiment**

Two postures for experiment are: 1) Nodes are static, because person is in static condition. 2) Nodes are mobile, because person is moving in the form of running or just walking.

- **Path Loss File**

The path loss data file is collected with some experiments conducted when a man is running on a treadmill and all these 6 sensor nodes are attached to him [48]. It can be understood in the following way, as 0>1:56 means when node 0 sends packets to node 1, a path loss of 56dBm is experienced by it. Path Loss File data is shown below:

```
0>1:56, 2:40, 3:59, 4:54, 5:58
1>0:56, 2:52, 3:52, 4:58, 5:61
2>0:40, 1:52, 3:58, 4:54, 5:61
3>0:59, 1:52, 2:58, 4:50, 5:63
4>0:54, 1:58, 2:54, 3:50, 5:63
5>0:58, 1:61, 2:61, 3:63, 4:63
```

- **BANRADIO File**

BANRADIO file is radio parameter file of Castalia. It consists of RX Modes, TX levels, Delay transition Matrix and Power Transition Matrix. They are described as below:

- **RX Modes**

RX Modes contains these parameters Name (high, low or ideal), data-rate, Modulation type, bits per symbol, bandwidth, noise band-width, noise floor, sensitivity and power-consumed. Name is a string and all other parameters are numeric. Each Name (high, low or ideal) has its own parameters value.

Table 4.1 RX Modes Parameters

Name	High	Low	IDEAL
DataRate(kbps)	1024	512	1024
Modulation Type	DIFFQPSK	DIFFBPSK	IDEAL
BitsPerSymbol	2	1	2
Bandwidth(MHz)	20	20	20
NoiseBandWidth(MHz)	1000	1000	1000
NoiseFloor(dBm)	-104	-104	-104
Sensitivity(dBm)	-87	-91	-87
PowerConsumed(mW)	3.1	3.1	3.1

TX Levels

TX levels has two parameters, Tx dBm and Tx mW. Tx dBm provides output power in dBm for various transmission levels. Tx mW gives the energy spent for each transmission level of Tx dBm.

Table 4.2 Tx Levels Parameters

Tx dBm	-10	-12	-15	-20	-25
Tx mW	3.0	2.96	2.93	2.9	2.9

Delay Transition Matrix

There are three radio states in Castalia: RX (Receive), TX (Transmit) and SLEEP. Delay Transition Matrix gives the delays in milliseconds occurs during switching between these states e.g. it takes 0.194 ms to switch from SLEEP to either RX state or TX state.

Table 4.3 Delay Transition Matrix

--	RX	TX	SLEEP
RX	-	0.02	0.194
TX	0.02	--	0.194
SLEEP	0.05	0.05	--

Power Transition Matrix

Power transition matrix gives the details about the power consumed in mW for different state switches mentioned in delay transition matrix.

Table 4.4 Power Transition Matrix

--	RX	TX	SLEEP
RX	-	3.0	3.0
TX	3.0	--	3.0
SLEEP	1.5	1.5	--

4.3 Mathematical Model

After simulation setup, a mathematical model is applied in it using Castalia to obtain more optimized and accurate results. The major focus is to compare REEA algorithm with existing approaches in terms of energy consumption.

- There are m number of body area networks sensor nodes represented by set $M=\{1,2,.....m\}$.
- Nodes are placed in a predefined topology such that different number of paths are represented by set $X=\{x1, x2... \}$. Nodes can act as information source, sink or relay node.
- Energy of nodes is represented by set E .

- M -represent set of body area networks sensor nodes
- X -represent set of paths
- E -represent set of energy of nodes
- N -represent number of hops
- B -represent number of bits sent
- E_T -represent Transmission Energy
- E_P -represent Processing Energy
- E_R -represent Remaining Energy
- E_I -represent Initial Energy
- L - represent loss of energy

Transmission Energy is given by:-

- $E_T = H * B * E_P * L^2$ (1)

- $E_R = E_I - E_T$ (2)

In general, path loss (returned in DB) is determined by average path loss modelling by:

- $PL(d) = PL(d_0) + 10.\eta.\log\left(\frac{d}{d_0}\right) + X\sigma$ (3)

$PL(d)$ = loss of path at d distance

$PL(d_0)$ = Path loss at a known distance d_0

η = exponent for path loss

$X\sigma$ = Random Variable with zero mean and σ variation

4.4 Routing Algorithm for Proposed Reliable Energy Efficient Adaptive Algorithm

REEA algorithm is described below in steps:

1. Let TE_{th} denotes Threshold Energy Level
2. Let TH_{th} denotes Threshold Hop Count
3. Let TLQ_{th} denotes Threshold Link Quality

4. Let Two available routes are considered \mathbf{R}_A and \mathbf{R}_B

5. Selected Route is \mathbf{R}_A

6. If $\mathbf{R}_A(\text{Energy}) = \mathbf{R}_B(\text{Energy})$

{

 If $\mathbf{R}_A(\text{Hop Count}) \geq \mathbf{R}_B(\text{HopCount}) + \text{TH}_{\text{th}}$

 {

 If $\mathbf{R}_A(\text{Negative Link Counter}) \geq \mathbf{R}_B(\text{Negative Link Counter})$

 {

 ChoosePath (\mathbf{R}_B)

 }

 }

}

7. Else if $\mathbf{R}_B(\text{Energy}) > \mathbf{R}_A(\text{Energy})$

{

 If $\mathbf{R}_A(\text{Hop Count}) + \text{TH}_{\text{th}} \geq \mathbf{R}_B(\text{HopCount})$

 {

 If $\mathbf{R}_A(\text{Negative Link Counter}) \geq \mathbf{R}_B(\text{Negative Link Counter})$

 {

 ChoosePath (\mathbf{R}_B)

 }

 }

}

8. Else if $\mathbf{R}_A(\text{Energy}) > \mathbf{R}_B(\text{Energy}) \ \&\& \ \mathbf{R}_A(\text{Energy}) < \mathbf{R}_B(\text{Energy}) + \text{TLQ}_{\text{th}}$

{

 If $\mathbf{R}_A(\text{Negative Link Counter}) \geq \mathbf{R}_B(\text{Negative Link Counter}) \ \&\&$

$\mathbf{R}_A(\text{Hop Count}) > \mathbf{R}_B(\text{HopCount}) + \text{TH}_{\text{th}}$

 {

 ChoosePath (\mathbf{R}_B)

 }

}

5. Simulation Results

Reliable Energy Efficient Adaptive algorithm is stimulated using Castalia 3.3 simulator. The Castalia framework based simulations are used to analyse the REEA algorithm performance and compared with AODV and link quality based routing algorithm. They are compared on the basis of many network factors. Most important factor is energy consumption and others are network latency, packet delivery ratio and packet loss rate.

5.1 Simulation Parameters

Some experiments were conducted by researchers to set threshold values for Body Area Networks simulation. According to Machado *et. al.* [49], on the basis of extensive experiments conducted, best suitable value for Threshold link quality TLQ_{th} is 220, for Hop Count Threshold Value TH_{th} is 4 and for Threshold energy level TE_{th} is 2. For simulating REEA algorithm, these same threshold values are taken. To get these threshold values extensive experiments were conducted by the researchers in an indoor environment of Computer science Department at Federal University [49]. 9 nodes were fixed on the roof and corridor forming a 3*3 grid topology. This was a real test bed experiment in which even people are moving in the room to get real information in the presence of such interference and noise causing path loss. Most of the applications requires more than 80% packet delivery ratio for quality of service requirements. That's why Threshold link quality was chosen to be 220 because below that packet delivery ratio was less than 80%. To get threshold energy level, real hardware experiments were conducted and it was found that network lifetime starts decreasing, if TE_{th} is greater than 6. TE_{th} is chosen 2, because according to experiments results network lifetime is highest at this value. It was not possible to choose hop count threshold level just by test-bed experiments due to limited number of hops. So, packet delivery ratio for number of hops ranging from 2 to 10 is analysed using some simulations. And it was found that hop count of 4 was best suitable in this case according to network size. A hop count greater than 4 can cause a large number of alternate routes and network overhead increases. Other simulation parameters are summarised in table 5.1

Table 5.1 Simulation Parameters

Parameter	Value
Number of Nodes	6
Sink Node	0
Simulation Time	51s (50 sec data+1 sec Tunable MAC setup)
Delay Time	1 sec
Packet Data Rate	5
Initial Energy	18,729 J (2 AA batteries)
Radio Model	BANRadio
TLQ_{th}	220
TH_{th}	4
TE_{th}	2

5.2 Results

The proposed Reliable Energy Efficient Adaptive algorithm for body area networks is compared with the results of AODV and Link quality based Routing algorithm. The routing algorithms are compared in two conditions:

- i) Without temporal variations
- ii) With Temporal variations

Figure 5.1 shows the Linux view of running simulations. Two output files are generated one for showing results without temporal variations and other for showing results with temporal variations. Figure 5.2 shows the Generated Castalia output files view for both simulations. Both output files without temporal variations and with temporal variations are shown in figure 5.3 and figure 5.4 respectively.

```

Terminal
priya@priya-VirtualBox: ~/Castalia-3.3/Simulations/thesis
priya@priya-VirtualBox:~$ cd Castalia-3.3/
priya@priya-VirtualBox:~/Castalia-3.3$ cd Simulations/
priya@priya-VirtualBox:~/Castalia-3.3/Simulations$ cd thesis/
priya@priya-VirtualBox:~/Castalia-3.3/Simulations/thesis$ ../../bin/Castalia -c
[AODV,LABILE,REEA]
Running Castalia: Configuration 1/3 Run 1/1 Complete 100% T
ime taken 0:00:00.050000
Running Castalia: Configuration 2/3 Run 1/1 Complete 100% T
ime taken 0:00:00.047000
Running Castalia: Configuration 3/3 Run 1/1 Complete 100% T
ime taken 0:00:00.120000
priya@priya-VirtualBox:~/Castalia-3.3/Simulations/thesis$ ../../bin/Castalia -c
[AODV_Temp,LABILE_Temp,REEA_Temp]
Running Castalia: Configuration 1/3 Run 1/1 Complete 100% T
ime taken 0:00:00.073000
Running Castalia: Configuration 2/3 Run 1/1 Complete 100% T
ime taken 0:00:00.076000
Running Castalia: Configuration 3/3 Run 1/1 Complete 100% T
ime taken 0:00:00.120000
priya@priya-VirtualBox:~/Castalia-3.3/Simulations/thesis$ █

```

Figure 5.1 Running Simulations

```

priya@priya-VirtualBox: ~/Castalia-3.3/Simulations/thesis
priya@priya-VirtualBox:~$ cd Castalia-3.3/
priya@priya-VirtualBox:~/Castalia-3.3$ cd Simulations/
priya@priya-VirtualBox:~/Castalia-3.3/Simulations$ cd thesis/
priya@priya-VirtualBox:~/Castalia-3.3/Simulations/thesis$ ../../bin/CastaliaResults
Castalia output files in current directory:
+-----+-----+-----+
| | Configuration | Date |
+-----+-----+-----+
| 150527-161237.txt | [AODV_Temp,LABILE_Temp,REEA_Temp] (1) | 2015-05-27 16:12 |
| 150527-161219.txt | [AODV,LABILE,REEA] (1) | 2015-05-27 16:12 |
+-----+-----+-----+
NOTE: select from the available files by running CastaliaResults FILE [FILE]
priya@priya-VirtualBox:~/Castalia-3.3/Simulations/thesis$ ../../bin/CastaliaResults █

```

Figure 5.2 Generated Castalia Output files

Module	Output	Dimensions
Application	Application level latency, in ms	1x1(31)
	Energy nJ/bit	1x1
	Packets loss rate	1x1
	Packets received per node	1x1
	Packets reception rate	1x1
Communication.MAC Communication.Radio	TunableMAC packet breakdown	6x1(4)
	RX pkt breakdown	6x1
	TXed pkts	6x1
ResourceManager	Consumed Energy	6x1
	Estimated network lifetime (days)	1x1
Simulation	Remaining Energy	6x1
	Execution ratio (simtime/realtime)	1x1
	Execution time, seconds	1x1

Figure 5.3 Output File (without Temporal Variation)

Module	Output	Dimensions
Application	Application level latency, in ms	1x1(31)
	Energy nJ/bit	1x1
	Packets loss rate	1x1
	Packets received per node	1x1
	Packets reception rate	1x1
Communication.MAC	TunableMAC packet breakdown	6x1(4)
Communication.Radio	RX pkt breakdown	6x1(2)
	TXed pkts	6x1
ResourceManager	Consumed Energy	6x1
	Estimated network lifetime (days)	1x1
	Remaining Energy	6x1
Simulation	Execution ratio (simtime/realtime)	1x1
	Execution time, seconds	1x1
wirelessChannel	Fade depth distribution	1x1(14)

Figure 5.4 Output File (With Temporal Variation)

- **Packet Reception Ratio**

Packet reception ratio is the ratio of number of packets received to the total number of packets sent in the network. When all the three routing algorithms are simulated with same simulation parameters and other conditions, it was found that for such simulated network REEA routing algorithm has best packet reception ratio and other protocols AODV and link quality based both are merely same. Following graph shows this comparison in a more descriptive way.

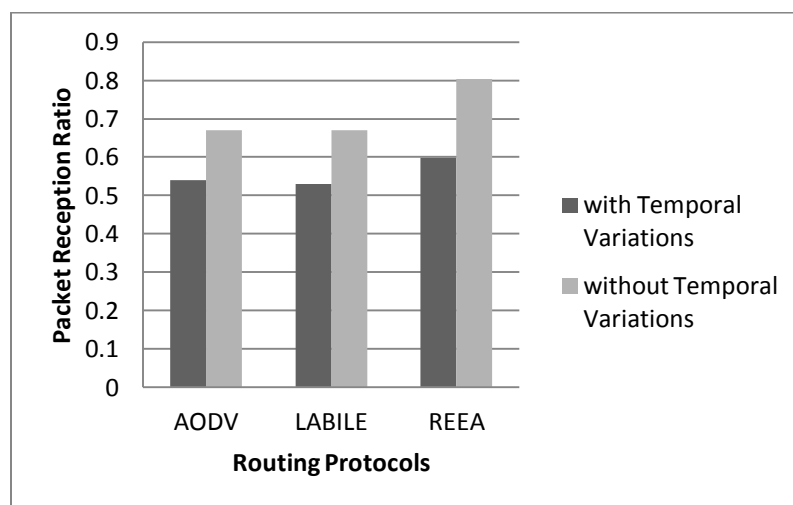

Figure 5.5 Graph representing Packet Reception Ratio

By analysing the above scenario, it was found that in case of without temporal variations there is an increase by 20% in packet delivery ratio and in the presence of temporal variations, there is increase by 13% in packet delivery ratio.

- Energy Consumption**

Minimising energy consumption is the main issue for proposing the reliable energy efficient adaptive routing algorithm. Energy consumption is calculated using total energy consumed divided by number of bits sent in the network. The results of AODV and link quality based protocols are merely same because both algorithms don't take into account the concept of energy management. On analysing the results of energy consumption, it was found that REEA is successful in minimising the energy consumption. There is very small amount of energy saved using REEA because of such small network of just six nodes. Figure 5.6 shows how energy consumption varies in all the three routing algorithm simulation.

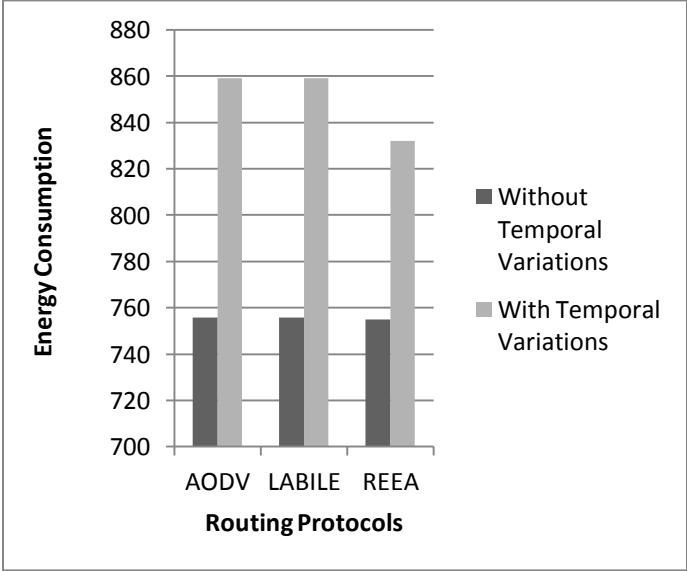

Figure 5.6 Graph representing Energy nJ/bit

In case of without temporal variations, results are approximate same but in case of temporal variations, REEA works better as compared to others. And there is 3%

less energy consumption by REEA which indirectly increases network lifetime also.

- **Packet Breakdown**

Figure 5.7 and 5.8 shows the packet breakdown structure in case of both temporal variations and non-temporal variations.

Communication.MAC:TunableMAC packet breakdown

	Received from App	filtered, other dest	received data pkts	sent data pkts
AODV,node=0	1	0	257	1
AODV,node=1	1	251	6	1
AODV,node=2	1	251	6	1
AODV,node=3	253	0	5	253
AODV,node=4	1	251	6	1
AODV,node=5	1	251	6	1
LABILE,node=0	1	0	257	1
LABILE,node=1	1	251	6	1
LABILE,node=2	1	251	6	1
LABILE,node=3	253	0	5	253
LABILE,node=4	1	251	6	1
LABILE,node=5	1	251	6	1
REEA,node=0	51	0	507	51
REEA,node=1	51	251	256	51
REEA,node=2	51	251	256	51
REEA,node=3	303	0	255	303
REEA,node=4	51	251	256	51
REEA,node=5	51	251	256	51

Figure 5.7 TunableMAC packet Breakdown (without temporal variations)

Communication.MAC:TunableMAC packet breakdown

	Received from App	filtered, other dest	received data pkts	sent data pkts
AODV_Temp,node=0	1	0	227	1
AODV_Temp,node=1	1	240	5	1
AODV_Temp,node=2	1	235	6	1
AODV_Temp,node=3	253	0	5	253
AODV_Temp,node=4	1	242	4	1
AODV_Temp,node=5	1	198	5	1
LABILE_Temp,node=0	1	0	227	1
LABILE_Temp,node=1	1	240	5	1
LABILE_Temp,node=2	1	235	6	1
LABILE_Temp,node=3	253	0	5	253
LABILE_Temp,node=4	1	242	4	1
LABILE_Temp,node=5	1	198	5	1
REEA_Temp,node=0	51	0	467	51
REEA_Temp,node=1	51	244	239	51
REEA_Temp,node=2	51	228	237	51
REEA_Temp,node=3	303	0	229	303
REEA_Temp,node=4	51	241	232	51
REEA_Temp,node=5	51	203	219	51

Figure 5.8 TunableMAC packet Breakdown (with temporal variations)

6. Conclusion and Future Scope

6.1 Conclusion

With the help of hop-count, residual energy and link quality of end-to end paths between the nodes a reliable energy efficient adaptive algorithm has been proposed.

The proposed routing algorithm gives more efficient and reliable outcomes as compared to existing routing algorithms for body area networks. With the help of mathematical formulation of the given problem, energy calculation formula is mathematically presented. Use of piggybacking scheme in which nodes communicates with their neighbor nodes and tells about their residual energy is a good approach for minimizing energy consumption. Amalgamating this piggyback scheme for residual energy with hop count and link quality helps in minimizing energy consumption and packet loss rate. Proposed routing algorithm is self-adaptive as the residual energy keeps on updating itself and RSSI strength helps in evaluating link quality. This algorithm is free from energy-hop or hot-spot problem and has load balancing feature which avoids premature death of closer nodes to the sink.

The proposed algorithm is evaluated using Castalia simulation and compared with existing approaches. Obtained results conclude that the REEA algorithm is far better than existing approaches and has less energy consumption. REEA algorithm for just six nodes increases the packet delivery ratio by 20% in case of without temporal variations and by 13 % in case of with temporal variations and decreases the energy consumption by 3% in case of with temporal variations. The simulation is done for a smaller network, but in the case of larger networks REEA algorithm can be very helpful because reduced energy consumption directly increases the network lifetime.

6.2 Future Scope

These limitations and the future work that can resolve the issues are given as follows:

- Increased network lifetime and decreased energy consumption is one of the major requirement of any successful routing algorithm for low power devices. Proposed

routing algorithm is evaluated on a small network and for a small network it has less energy consumption but there are no changes in the expected lifetime. So, in the future the primary aim will be increasing the network lifetime by utilizing the characteristics metrics more efficiently.

- The proposed algorithm has been evaluated for a small network only because in body area network there is path loss due to movement of nodes and till now, NICTA has provided path loss file only for these six nodes to make experiments realistic [48]. Hardware implementation to get realistic path loss file for larger networks is not possible due to major hardware requirements. Thus in future, the proposed work can be extended by working on larger networks with the help of realistic path loss file
- The proposed work uses the threshold values already given by researchers. In future, the proposed work can be analyzed by varying these thresholds to get some other important results which may be helpful.
- In future, hardware implementation of proposed work can be done to get more optimized results.

7.1 January 2015

- **Descriptive**

It was the initial phase when I started working on my Master's Research. In starting, "research" word seems to be very new to me. It was the phase when first time I felt the difference between doing Master's and Bachelor's. This was the phase when my mentor was helping me to understand the real meaning of "research".

- **The Reflection**

I stated this event because initially when we enter from Bachelor's to Master's, many of us didn't know "what is research?". My mentor guided me in the best way possible and make me understand research is not just related to publish research papers or just writing thesis.

- **The Outcome**

My mentor made me free to choose any research topic in the field of networks. I started doing Google (one of the best friend of an engineering student). Not only this, I even read some survey papers mainly on MANETs, VANETS, Smart Cities and Body Area Networks (BAN). Then, I went to my guide with my initial research.

7.2 February, 2015

- **Descriptive**

This was the time when I and my mentor started discussing on the initial research done by me. We discussed whole week on each and every topic, I had searched in the last month. In starting of this month, I used to have these research sessions with my guide regularly.

- **The Reflection**

I choose this event because I want to emphasize why these kind of research discussions are very important to choose a research topic. These healthy sessions will help you to choose best research topic according to your interest and in the guidance of your mentor. At that time, sometimes these discussions made me very uneasy when our views didn't match. But now, I understood those healthy discussions was my first step towards the world of research. After those discussions, we came on this very demanding research topic "Body Area Networks" and started working in this field. I started searching good journals papers on "Body Area Networks" and shortlisted few of them. In starting, I mainly read survey papers to get an overview of BAN and the related terms. I gained the knowledge about the theoretical stuff and presented to my mentor about what I learnt. But in fact she gave a few more terms which she expected me to come through. And then from survey papers I switched to a book written on BAN to get a thorough knowledge about this field.

- **The Outcome**

I learnt that the time has come to think out of the box. To come with some rational ideas about where such knowledge can be used and how it can be implemented. I just came to a realization to research about the topic thoroughly before presenting anything.

7.3 March, 2015

- **Descriptive**

I am stating this incident because at a point of time during my research I was at a standstill. Thus had no clue where to move or rather to take a move or not. It was the time when I asked my mentor to change my project and I was even ready to give a new start.

- **The Reflection**

This event made me very uneasy but still it was one of the most memorable moments. I was working on my research topic “Body Area Networks” for two months but felt myself got stuck in between. I was learning new tool “Omnet++” and “Castalia” to implement BAN simulations but I was getting lots of issues to understand these tools completely. I joined many Google groups based on these topics and posted my issues but there were no replies. I tried reading through their It was nothing more than a challenge for me to come with a solution.

My mentor boosted me up, for the research I have done and did not wanted that 2 months to just get waste. After few days I came across a reply from the Google group members which gave me a start so that I could move forward.

My patience really paid off and I started working back to the same project.

- **The Outcome**

One must not lose hope. If someone has really worked hard, their hard work pays off. One needs to be open with his/her mentor so that he/she can guide us in right direction.

7.4 April, 2015

- **Descriptive**

It was the first time when I attended an International IEEE conference and presented my views on Body Area Networks. The time when I had to show what I have been doing since last 3 months.

- **The Reflection**

I decided to reflect this event because it was the Big day or memorable day of my life, giving a presentation at such a phase of life, when I was only a postgraduate student. The thing that surprised me was that everyone listened to me very carefully during the presentation. They even clarified their doubts and gave me their suggestions for my further research.

- **The Outcome**

This presentation was different from the presentations given in the undergraduate curriculum. The members came prepared with the background of everyone's research area and gave many helpful suggestions.

This incident erased the fear of presentation from my personality. With this presentation, I learnt that no one should bluff in the presentation. There should be a proper evidence of what he/she is going to present with a conceptual proof.

7.5 May, 2015

- **Descriptive**

This was the last month of my Master's Degree and I had started working on Castalia, BAN simulator in order to finally simulate the algorithm proposed. After that, thesis writing process began which finally ends in the month of June.

- **The Reflection**

In the month of January, I had a different perception in my mind. I was very new to OMNET++ and Castalia, BAN simulators. During this complete thesis phase, many of the times I thought I would not be able to do this work. But then my mentor asked me to just give it a try. I started working on it and explored a lot in this field.

To my surprise it was not that much difficult. I learnt new concepts and finally felt a sigh of relief when i got expected results for my algorithm proposed. In this month, I even communicated one more research paper in order to reflect whole of my thesis work.

- **The Outcome**

I was always bounded to my limited skills before working in Body Area Networks. Before that, I never got a chance to do something new. So, for research or for thesis i would suggest explore and never give up is the key to success.

8. Video Presentation

Video Presentation Link---- <https://youtu.be/ICGu-sajx3o>

References

- [1] B. Latré, B. Braem, I. Moerman, C. Blondia, and P. Demeester, “A survey on wireless body area networks,” *Wirel. Networks*, vol. 17, no. 1, pp. 1–18, 2011.
- [2] M. Chen, S. Gonzalez, A. Vasilakos, H. Cao, and V. C. M. Leung, “Body area networks: A survey,” *Mob. Networks Appl.*, vol. 16, no. 2, pp. 171–193, 2011.
- [3] S. Movassaghi, M. Abolhasan, J. Lipman, D. Smith, and A. Jamalipour, “Wireless Body Area Networks: A Survey,” *IEEE Commun. Surv. Tutorials*, vol. 16, no. 3, pp. 1658–1686, 2014.
- [4] T.G. Zimmerman, “Personal Area networks near field intrabody communication ” , *IBM Systems Journal*, vol. 35, pp. 609-617,1996.
- [5] C.C.Y. Poon, S.D. Bao and Y.T. Zhang, "A Novel Biometrics Method to Secure Wireless Body Area Sensor Networks for Telemedicine and M-Health," *IEEE Communication Magazine*, vol. 44,no. 4, pp. 73-81, 2006.
- [6] D. Curtis, E. Shih, J. Waterman, J. Guttag, J. Bailey, T. Stair, R. a. Greenes, and L. Ohno-Machado, “Physiological signal monitoring in the waiting areas of an emergency room,” *Proc. ICST 3rd Int. Conf. Body area networks*, pp. 1-8 ,2008.
- [7] S. Jiang, Y. Cao, S. Iyengar, P. Kuryloski, R. Jafari, Y. Xue, R. Bajcsy, and S. Wicker, “CareNet: an Integrated Wireless Sensor Networking Environment for Remote Healthcare,” *Proc. BodyNets'08 ICST 3rd Int. Conf. Body area networks*, 2008.
- [8] R. S. H. Istepanaian and Y.-T. Zhang, “Guest editorial. Introduction to the special section: 4G Health--the long-term evolution of m-Health.,” *IEEE Trans. Inf. Technol. Biomed.*, vol. 16, no. 1, pp. 1–5, 2012.

- [9] B. Atakan, O. B. Akan, and S. Balasubramaniam, "Body area nanonetworks with molecular communications in nanomedicine," *IEEE Commun. Mag.*, vol. 50, no. 1, pp. 28–34, 2012.
- [10] C. Cordeiro, "Use cases, applications, and requirements for bans," Doc.: IEEE802, 2007.
- [11] X. Lai, Q. Liu, X. Wei, W. Wang, G. Zhou, and G. Han, "A survey of body sensor networks," *Sensors*, vol. 13, no. 5, pp. 5406–5447, 2013.
- [12] C. Otto and a Milenkovic, "System architecture of a wireless body area sensor network for ubiquitous health monitoring," *Journal of Multimedia* vol. 1, no. 4, pp. 307–326, 2006.
- [13] K. Van Dam, S. Pitchers, and M. Barnard, "Body area networks: Towards a wearable future," *Proc. WWRF kick off meeting, Munich, Germany*, pp. 6-7, 2001.
- [14] T. Zasowski, F. Althaus, M. Stager, a. Wittneben, and G. Troster, "UWB for noninvasive wireless body area networks: channel measurements and results," *IEEE Conf. Ultra Wideband Syst. Technol. 2003*, pp. 285–289, 2003.
- [15] C. Tachtatzis and F. Di Franco, "An energy analysis of IEEE 802.15. 6 scheduled access modes," *IEEE GLOBRCOM Workshops (GC Wkshps)*, pp. 1270–1275, 2010.
- [16] B. P. L. Lo, S. Thiemjarus, and R. King, "Body Sensor Network – A Wireless Sensor Platform for Pervasive Healthcare Monitoring," *Proc. of the 3rd International Conference on Pervasive Computing, Munich, Germany*, vol. 13, no. 2–3, pp. 77–80, 2005.
- [17] E. Strömmer, M. Hillukkala, and A. Ylisaukko-oja, "Ultra-low power sensors with near field communication for mobile applications," *Proc. of Wireless Sensor*

and Actor Networks IFIP WG 6.8 (WSAN'07), Albacete, Spain, vol. 248, pp. 131–142, 2007.

- [18] A. Natarajan, M. Motani, B. de Silva, K.-K. Yap, and K. C. Chua, “Investigating network architectures for body sensor networks,” *Proc. 1st ACM SIGMOBILE Int. Workshop on Systems and networking support for healthcare and assisted living environments, New York, USA*, pp. 19-24, 2007.
- [19] F. Di Franco, C. Tachtatzis, B. Graham, D. Tracey, N. F. Timmons, J. Morrison, P. Road, and C. Donegal, “On-body to On-body Channel Characterization,” *Sensors*, pp. 908–911, 2011.
- [20] T. Aoyagi, Iswandi, M. Kim, J. Takada, K. Hamaguchi, and R. Kohno, “Body motion and channel response of dynamic body area channel,” *Proc. 5th Eur. Conf. Antennas Propag.*, pp. 3138–3142, 2011.
- [21] E. Reusens, W. Joseph, B. Latré, B. Braem, G. Vermeeren, E. Tanghe, L. Martens, I. Moerman, and C. Blondia, “Characterization of on-body communication channel and energy efficient topology design for wireless body area networks,” *IEEE Trans. Inf. Technol. Biomed.*, vol. 13, no. 6, pp. 933–945, 2009.
- [22] S. Ullah, D. Kwak, C. Lee, H. Lee, and K. S. Kwak, “Numerical analysis of CSMA/CA for pattern-based WBAN system,” *Proc. 2009 2nd Int. Conf. Biomed. Eng. Informatics, BMEI 2009*, pp. 5–7, 2009.
- [23] B. Otal, L. Alonso, and C. Verikoukis, “Energy-efficiency analysis of a distributed queuing medium access control protocol for biomedical wireless sensor networks in saturation conditions,” *Sensors*, vol. 11, no. 2, pp. 1277–1296, 2011.
- [24] H. Li and J. Tan, “Heartbeat-driven medium-access control for body sensor networks,” *IEEE Trans. Inf. Technol. Biomed.*, vol. 14, no. 1, pp. 44–51, 2010.

- [25] S. Marinkovic and E. Popovici, "Ultra Low Power Signal Oriented Approach for Wireless Health Monitoring," *Sensors*, vol. 12, no. 6, pp. 7917–7937, 2012.
- [26] G. F. G. Fang and E. Dutkiewicz, "BodyMAC: Energy efficient TDMA-based MAC protocol for Wireless Body Area Networks," *9th Int. Symp. Commun. Inf. Technol.*, pp. 1455–1459, 2009.
- [27] T. Watteyne, I. Augé-Blum, M. Dohler, and D. Barthel, "AnyBody: a self-organization protocol for body area networks," *Proc. Second Int. Conf. Body Area Networks BodyNets*, 2007.
- [28] B. J. Culpepper, "Design and Analysis of Hybrid Indirect Transmissions (HIT) for Data Gathering in Wireless Micro Sensor Networks," *Communications*, vol. 3, no. 1, pp. 61–83, 2003.
- [29] M. Moh, B. J. Culpepper, L. Dung, T. S. Moh, T. Hamada, and C. F. Su, "On data gathering protocols for in-body biomedical sensor networks," *GLOBECOM - IEEE Glob. Telecommun. Conf.*, vol. 5, pp. 2991–2996, 2005.
- [30] S. Movassaghi, M. Abolhasan, and J. Lipman, "Energy Efficient Thermal and Power Aware (ETPA) Routing in Body Area Networks," *2012 IEEE 23rd Int. Symp. Pers. Indoor Mob. Radio Commun. -*, pp. 1108–1113, 2012.
- [31] M. Quwaider and S. Biswas, "Probabilistic routing in on-body sensor networks with postural disconnections," *Proc. 7th ACM Int. Symp. Mobil. Manag. Wirel. access - MobiWAC '09*, pp. 149–158, 2009.
- [32] M. Quwaider and S. Biswas, "DTN routing in body sensor networks with dynamic postural partitioning," *Ad Hoc Networks*, vol. 8, no. 8, pp. 824–841, 2010.
- [33] M. Quwaider and S. Biswas, "On-body Packet Routing Algorithms for Body Sensor Networks," *Ist Int. Conf. on Networks Commun.(NETCOM '09)*, pp. 171–177, 2009.

- [34] B. Braem, B. Latr'e, I. Moerman, C. Blondia, and P. Demeester, "The wireless autonomous spanning tree protocol for multihop wireless body area networks," *In proc. 3rd Annu. Int. Conf. on Mobile and Ubiquitous Systems: Networking Services*, pp. 1–8, 2006.
- [35] B. Braem, B. Latre, C. Blondia, I. Moerman, and P. Demeester, "Improving Reliability in Multi-hop Body Sensor Networks," *Second Int. Conf. Sens. Technol. Appl. (sensorcomm 2008)*, pp. 349–354, 2008.
- [36] A. G. Ruzzelli, R. Jurdak, G. M. . O'Hare, and P. Van Der Stok, "Energy-Efficient Multi-hop Medical Sensor Networking," *Proc. 1st ACM SIGMOBILE Int. Work. Syst. Netw. Support Healthc. Assist. living Environ. - Heal. '07*, pp. 37–42, 2007.
- [37] A. Bag and M. a. Bassiouni, "Biocomm – a cross-layer medium access control (MAC) and routing protocol co-design for biomedical sensor networks," *Int. J. Parallel, Emergent Distrib. Syst.*, vol. 24, no. 1, pp. 85–103, 2009.
- [38] A. M. Ortiz, N. Ababneh, N. Timmons, and J. Morrison, "Adaptive routing for multihop IEEE 802.15.6 wireless body area networks," *20th Int. Conf. on Software, Telecommunications and Computer Networks (SoftCOM)*, pp. 1–5, 2012.
- [39] Q. Tang, N. Tummala, S. K. S. Gupta, and L. Schwiebert, "Communication scheduling to minimize thermal effects of implanted biosensor networks in homogeneous tissue," *IEEE Trans. Biomed. Eng.*, vol. 52, no. 7, pp. 1285–1294, 2005.
- [40] A. Bag and M. a. Bassiouni, "Energy efficient thermal aware routing algorithms for embedded biomedical sensor networks," *IEEE Int. Conf. Mob. Ad Hoc Sens. Syst. MASS*, pp. 604–609, 2007.

- [41] D. Takahashi, Y. Xiao, F. Hu, J. Chen, and Y. Sun, "Temperature-aware routing for telemedicine applications in embedded biomedical sensor networks," *EURASIP Journal on Wireless Commun. Netw.*, 2008.
- [42] A. Bag and M. a Bassiouni, "Hotspot Preventing Routing Algorithm for Delay-sensitive Biomedical Sensor Networks," *IEEE Int. Conf. on Portable Information Devices (PORTABLE07)*, pp. 1–5, 2007.
- [43] A. Bag and M. a. Bassiouni, "Routing algorithm for network of homogeneous and id-less biomedical sensor nodes (RAIN)," *IEEE Sensors Applications Symp. (SAS)*, pp. 68 –73, 2008.
- [44] M. Tabandeh, M. Jahed, F. Ahourai, and S. Moradi , "A thermal-aware shortest hop routing algorithm for in vivo biomedical sensor networks," *6th Int. Conf. Inf. Technol. New Gener. (ITNG'09)* , pp. 1612–1613, 2009.
- [45] D. Djenouri and I. Balasingham, "New QoS and geographical routing in wireless biomedical sensor networks," *Sixth Int. Conf. Broadband Commun. Networks, Syst.*, 2009.
- [46] A. Razzaque, C. S. Hong, and S. Lee, "Data-centric multiobjective QoS-aware routing protocol for body sensor networks," *Sensors*, vol. 11, no. 1, pp. 917–937, 2011.
- [47] I. Balasingham, "A Reinforcement Learning based Routing Protocol with QoS Support for Biomedical Sensor Networks," *First Int. Symp. Appl. Sci. Biomed. Commun. Technol.*, pp. 1–5, 2008.
- [48] NICTA research data (online) , <http://www.nicta.com.au/>, (Acessed:1 April 2015).
- [49] K. Machado, D. Rosário, E. Cerqueira, A. Loureiro, and A. Neto, "A routing protocol based on energy and link quality for internet of things applications," *Sensors* ,pp. 1942-1964,2013.

List of Publications

1. Priya Juneja and Dr. Sushma Jain, “Tree Based Energy Efficient Routing Scheme for Body Area Network”, 2015 International Conference on Advances in Computer Engineering and Applications (ICACEA),IEEE Explore,2015, [Accepted]
2. Priya Juneja and Dr. Sushma Jain, “Reliable Energy Efficient Adaptive Routing Algorithm for Body Area Networks” [To be communicated]