

# Integration of Animal Power with other Renewable Energy Systems for Off-Grid Stations

A Dissertation submitted in fulfillment of the requirements for the degree  
of

**MASTER OF ENGINEERING**

*in*

**Electronic Instrumentation and Control Engineering**

*Submitted by*

Harpreet Sharma  
(801451008)

*Under the guidance of*

Mr. Mooninder Singh  
Assistant Professor,  
EIED, Thapar University,  
Patiala



**Electrical And Instrumentation Engineering Department  
Thapar University, Patiala**

*(Declared as Deemed-to-be-University u/s 3 of the UGC Act., 1956)*

**Post Bag No. 32, Patiala 147004**

**Punjab (India)**

**July, 2015**

# DECLARATION

I hereby certify that the work which is presented in dissertation entitled, "*Integration of Animal Power with other Renewable Energy Systems for Off-Grid Stations*", in fulfillment of the requirements for the award of the degree of Master of Engineering in Electronics and Instrumentation Control, submitted to Electrical & Instrumentation Engineering Department of Thapar University, Patiala is as authentic record of my own work carried under the supervision of Mr. Mooninder Singh. It refers others researchers work which are duly listed in the reference section. The matter contained in this dissertation has not been submitted, neither in part nor in full to any other degree to any other university or institute except as reported in text and references.

Place: Patiala

Date: 20/07/2016

Harpreet Sharma  
(Harpreet Sharma)

Roll No.:

801451008

It is certified that the above statement made by the student is correct to the best of my knowledge and belief.

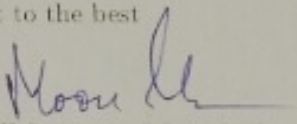
  
(Mr. Mooninder Singh)

Assistant Professor  
Electrical & Instrumentation Engineering Department  
Thapar University, Patiala

Date: 20/07/2016

Countersigned by:

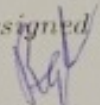
  
(Dr. Ravinder Agarwal)  
Head  
Electrical & Instrumentation Engineering Department  
Thapar University,  
Patiala

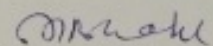
  
(Dr. S.S. Bhatia)  
Dean (Academic Affairs)  
Thapar University,  
Patiala

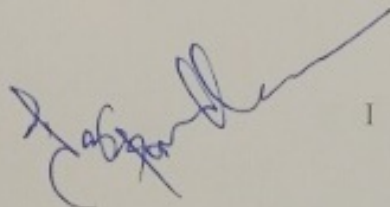
  
1

# CERTIFICATE

Certified that the dissertation entitled, **Integration of Animal Power with other Renewable Energy Systems for Off-Grid Stations**, which is being submitted by Harpreet Sharma in fulfillment of the requirements for the award of the M.E. in Electronic Instrumentation Control, to Thapar University, Patiala, is a bona-fide record of the candidates own work carried out by him/her under our/my supervision and guidance. The matter contained in this dissertation has not been submitted, neither in part nor in full to any other university or institute for award of any degree.

Date:

Mr. Mooninder Singh

Place:

Assistant Professor

Head, Elcetrical and instrumentation Engg Dept.

Dean of Academic Affairs

# ACKNOWLEDGEMENT

I would like to take the opportunity to express my gratitude to some people who were involved in this dissertation work. First, I owe my gratitude to my mentor **Mr. Mooninder Singh (assistant professor)** Electrical and Instrumentation department, for doing everything from the inception of the work idea to giving incredible suggestions at every step.

I am also thankful to **Dr. Ravinder Agarwal**, Head of the Department and **Mr. Nirbhowjap Singh**, PG Coordinator as well as all the faculty members and staff of the Department of Electrical and Instrumentation Engineering for being very supportive to me. I am also thankful to **Dr. Mandeep Singh (associate professor)** Electrical and Instrumentation department, for the motivation and inspiration that triggered me to work. I would also like to thank all my batchmates especially **Inderjeet Singh** for motivating me all the time whenever I needed them and giving me useful tips. I thank all those who have contributed directly or indirectly to this work.

Lastly, I would also like to thank my parents for their years of unyielding love and encourage. They have always wanted the best for me and I admire their determination and sacrifice.

Harpeet Sharma  
801451008



# CONTENTS

---

Declaration . . . . .	I
<b>1 INTRODUCTION</b>	<b>1</b>
1.1 Motivation . . . . .	1
1.2 Micro Integrated Power System . . . . .	4
1.3 Software Simulation . . . . .	5
1.4 Objectives of Study . . . . .	6
1.5 Outline of Thesis . . . . .	6
<b>2 LITERATURE SURVEY</b>	<b>7</b>
<b>3 CASE STUDY: Experimental Study on Animal Powered Mechanical Device for Home Lighting System</b>	<b>17</b>
3.1 System Description . . . . .	17
3.2 Component Sizing . . . . .	19
<b>4 SIMULATION AND MODELLING</b>	<b>23</b>
4.1 Dynamic Simulation and Modelling . . . . .	23
4.2 Software Environment . . . . .	24
4.3 Simulation Models . . . . .	24
4.3.1 Photovoltaic Generator . . . . .	25
4.3.2 Alternator . . . . .	25
4.3.3 Converter . . . . .	26
4.3.4 Fuzzy Controller . . . . .	27
4.3.5 Lead-Acid Batteries . . . . .	29
4.3.6 PWM based Inverter Model . . . . .	30
<b>5 RESULTS AND DISCUSSION</b>	<b>33</b>
<b>6 CONCLUSION</b>	<b>35</b>
<b>7 FUTURE SCOPE</b>	<b>37</b>



## LIST OF FIGURES

---

1-1	Electricity index of various states . . . . .	2
1-2	Generalised model of fuzzy controller . . . . .	3
1-3	Generalised model of Micro Integrated System . . . . .	3
3-1	Bull Powered Generator . . . . .	18
3-2	Components used in Bull Powered Generator . . . . .	19
3-3	Battery and Alternator Connections . . . . .	21
4-1	Block-Oriented data flow . . . . .	23
4-2	Intensity Variations . . . . .	25
4-3	VI Characteristics of Photovoltaic Generator . . . . .	26
4-4	Single phase Alternator . . . . .	26
4-5	Fully controlled Converter . . . . .	27
4-6	Simulink Block of Fuzzy Controller . . . . .	28
4-7	Fuzzy GUI . . . . .	28
4-8	Battery . . . . .	29
4-9	Simulink block of Battery . . . . .	30
4-10	PWM based Inverter . . . . .	30
5-1	Simulink model of Complete Integrated System . . . . .	33
5-2	Voltage of DC Link . . . . .	34
5-3	Output AC voltage . . . . .	34



## LIST OF TABLES

---

1.1	Details of Bullocks by Sex, Age and Use in Rural Areas for Male (19TH LIVESTOCK CENSUS-2012 . . . . .	5
3.1	Animal speeds, Output powers and weight . . . . .	18
4.1	Battery Parameters . . . . .	29

# ABSTRACT

The described study comprises of modelling with the dynamic simulation of micro integrated power system. Intended to provide electricity for remote off-grid stations by using animal power integrated with other renewable systems. Although the number of draught animals is huge, but their potential for power generation has not been considered. This work provides novel approach for generation and control of power. It consists of a Photovoltaic generator, Diesel generator set, high output alternator, fully controlled converter, fuzzy controller, battery bank and an inverter. All the simulation required for the system is implemented using MATLAB/Simulink simulation environment. Animal power serves not only as alternative source for power generation but also provides stability to the system. Fuzzy logic based controller is applied to control and maintain the DC output from converter at constant value by controlling the firing angle of converter. Fuzzy logic controller has been found appropriate for controlling the output DC link .With the use of this simulation model, virtual experiments are carried out that give graphical results which mimics the experimental results. Successful simulation of generation and control of power has been achieved. The power at output can be stored in batteries or can be used directly after conversion to AC voltage using inverter. This proposed method is free from emission, low installation cost, low maintenance, long life and any skilled or unskilled person can run the system

# CHAPTER 1

## INTRODUCTION

---

*“Initiative is doing the right thing without being told” -Victor Hugo*

### 1.1 Motivation

Animal power is of worthy consideration in family of renewable source for stationary and flexible applications. Animal energy is readily available and it is being used from the beginning of civilisation for various agricultural works or for carrying loads. Draught power is the major source for rotary and tractive power. In 1961 the benefaction of the draught animals to the total power requirements in the sector of farming was 71%, which came down to 23%.<sup>3</sup>by the year 1991. But with increasing mechanisation in every field the population of draught animals is declining. India owns the supreme breeds of draught animals. Among all the animals bullocks Table 1.1 are the most productive and used. The bullock pair is known as the backbone of Indian agricultural works as presently in India there are 63 million draught animals Table ?? and each animal is capable of producing power of 0.5 hp. Thus using draught animal power for electricity generation can approximately produce 31 million hp. The use of animal power is in need to be promoted as the use of fossil fuels is not eco-friendly, sustainable and even it is leading to higher costs of agriculture. Animal energy is not getting full attention leading to extreme economic conditions in our country which is forcing farmers to commit suicide. Draught animal power has taken Indian agriculture to higher levels in the past but with passing time the use of animal power is dwindling. This leads to economic crisis creating huge disturbance by leaving male animals of no use. In this context animal power generators can be of significant importance as it is completely renewable, eco-friendly reducing the use of petroleum products.

The breach between increasing demand and availability of electricity in our country is an issue of great concern. The first step towards development of universal energy access is to bridge the gap between action and policy. There are countless remote rural areas with poor availability of electricity. The scarcity of electricity in such remote areas is such that it is not even sufficient for home lighting. Directly or indirectly effecting the countrys economy as lack of home lighting directly leads to poverty,

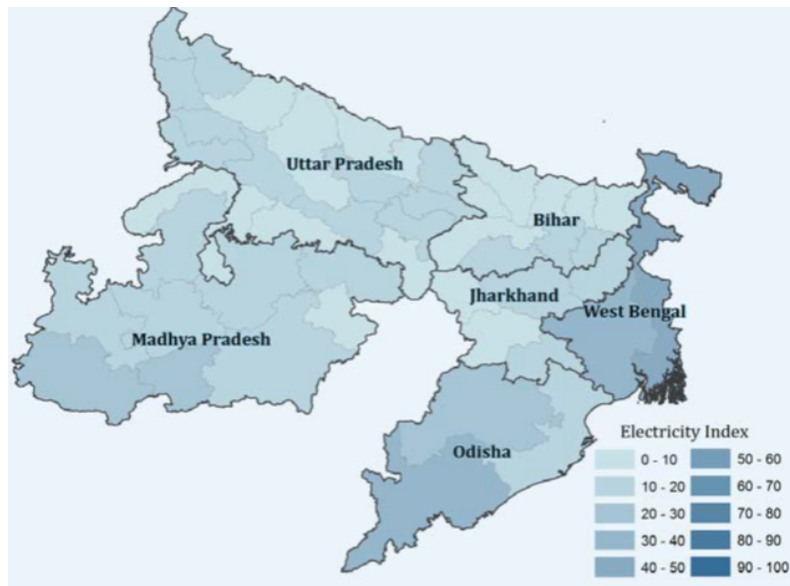

**Figure 1-1:** Electricity index of various states

health problems and illiteracy. In that context over 1.5 billion people figure 1-1 still rely on kerosene for lighting resulting in environmental pollution. It is a very costly and difficult operation to provide grid power for remote isolated areas. Figure 1-1 shows the variability of electricity index of various states of India. Darker shades represent areas of better electricity access. Most of the areas suffer from poor availability of electricity are the ones with lighter shades.

The renewable energy sources for electricity production are very much cost effective and emission free in comparison to non-renewable sources. As the non-renewable sources suffer various expenditures from:

- Fuel Costs
- Capital costs of machines and energy
- Supervision costs
- Maintenance costs

The requirement of control system Figure 1-2 is very critical. When there is variation in the output from stand-alone or an integrated system for power generation such as variation from loads, or due to variation in speed of animal stability is disturbed. Fuzzy logic based control system is applied to achieve the stability of the whole integrated system. MAMDANI type of fuzzy inference system is used to implement the

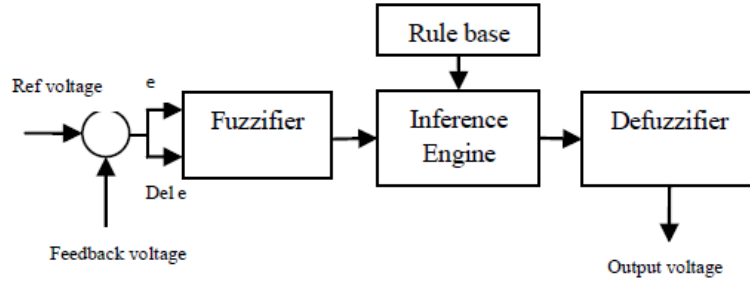

Figure 1-2: Generalised model of fuzzy controller

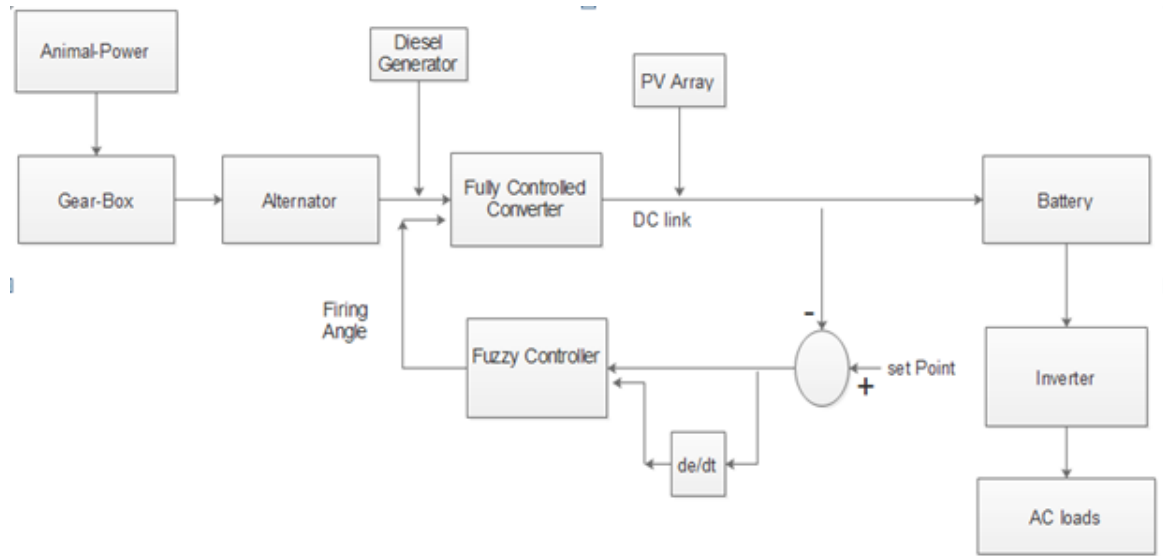

Figure 1-3: Generalised model of Micro Integrated System

control strategy. This system works with processing of Voltage error and error rate by keeping a check on the difference between the rated voltage and generator output. The fuzzy logic based controller is used to fix the output of generator to maintain it at a comparatively constant value by observing the difference between the output voltage and reference voltage.

Fuzzy logic based controller is a decision algorithm of non-mathematical type based on operators experience. This control strategy is well suited for no-linear processes such as synchronous generator. This type of control algorithm is used to exhibit non-linearity in between armature voltage and field current. Fuzzy logic based control has three parts: base rule, fuzzification, and defuzzification. Fuzzy logic based control has two inputs: error, rate of error and one output.

- Fuzzification: Conversion of real value to a fuzzy value using different types of membership functions known as fuzzifiers. Linguistic variables of fuzzy are used

for presenting various qualities covering a particular spectrum.

- Defuzzification: In this process quantifiable output in crisp logic is produced, with given fuzzy sets and equivalent membership degrees. Fuzzy control systems need defuzzification in their operation.
- Fuzzy Inference System: This system uses fuzzy logic theory to plot inputs (that consists of features of fuzzy classification) to outputs (that consists of classes of fuzzy classification). Examples of fuzzy inference system are MAMDANI and SUGENO.
- Rule Base: Fuzzy logic is linguistic rule based with IF-THEN instructions with general form of IF A THEN B in which A and B are collection of propositions those contain linguistic variables. A is known as premise and B is the result of the rule. The effect of usage of fuzzy IF-THEN rules and linguistic variables results in exploitation of tolerance for uncertainty and imperfection.

## 1.2 Micro Integrated Power System

There are a significant number of people who still rely on traditional power sources for the fulfilment of their energy requirement. But due to poor availability of electricity in remote areas the graph of quality of life is on declining side. Need to invention only arises when the level of extinction of resources is on the verge.

The non-renewable sources have drawbacks such as carbon emission, high investment and huge land requirement that motivate us towards the use of more and more renewable sources and integrated systems. Utilisation of renewable sources results in reduction of environmental pollution that helps in saving non-renewable resources and thus put mankind towards the sustainable power supply systems. The integration of animal power with solar power and diesel engine incorporated with a control system serves two objectives; firstly it provides an alternative source of power. Secondly provides stability to the entire system whenever there is a disturbance due to load, variation in animal speed and output of other sources.

The animal power generator Figure 1-3 consists of gear box, alternator, converter, control system, battery bank and an inverter. Bull power is converted to low torque

**Table 1.1:** Details of Bullocks by Sex, Age and Use in Rural Areas for Male (19TH LIVESTOCK CENSUS-2012)

SNo.	State/ UT	Male						Total Male
		Upto2 Years	Over 2 Years			Others		
			Used for Breeding only	Used for Drought only	Used for both Draught and Breeding			
1	ANDAMAN & NICOBAR ISLANDS	673	154	2393	718	97	4035	
2	ANDHRA PRADESH	1073548	69747	126844	28173	12506	1310818	
3	ARUNACHAL PRADESH	557	254	1025	433	328	2597	
4	ASSAM	43869	10465	91229	21527	3833	170923	
5	BIHAR	657268	51652	91671	35158	113558	949307	
6	CHANDIGARH	315	25	3	0	2	345	
7	CHHATTISGARH	102501	15923	604539	31660	9864	764487	
8	DADRA & NAGAR HAVELI	253	175	1304	140	43	1915	
9	DAMAN & DIU	43	14	0	5	0	62	
10	GOA	2557	1004	1459	689	193	5902	
11	GUJARAT	595926	82962	68711	24638	22868	795105	
12	HARYANA	751950	16842	66473	40297	7042	882604	
13	HIMACHAL PRADESH	52480	3562	342	312	2730	59426	
14	JAMMU & KASHMIR	51560	10831	9815	5265	690	78161	
15	JHARKHAND	85710	20351	389470	61244	7245	564020	
16	KARNATAKA	280562	17796	38021	4715	3948	345042	
17	KERALA	52172	1724	2548	790	9156	66390	
18	LAKSHADWEEP	0	0	0	0	0	0	
19	MADHYA PRADESH	916881	121797	145357	31361	24145	1239541	
20	MAHARASHTRA	361343	52014	124891	22935	4123	565306	
21	MANIPUR	8530	3543	6333	8131	784	27321	
22	MEGHALAYA	2032	2415	3395	5001	1617	14460	
23	MIZORAM	598	147	363	476	26	1610	
24	NAGALAND	4125	2595	4658	2817	701	14896	
25	NCR OF DELHI	17191	769	567	483	1032	20042	
26	ODISHA	59738	14037	235185	17655	3039	329654	
27	PUDUCHERRY	38	9	8	0	0	55	
28	PUNJAB	432913	16958	27069	32749	2424	512113	
29	RAJASTHAN	1370626	86493	37029	20954	17409	1532511	
30	SIKKIM	117	14	1	8	0	140	
31	TAMIL NADU	58737	12844	6113	3102	3452	84248	
32	TRIPURA	1436	489	1307	816	184	4232	
33	UTTAR PRADESH	3260194	160533	1015392	182460	101696	4720275	
34	UTTARAKHAND	82965	7188	17014	3048	482	110697	
35	WEST BENGAL	37164	7471	282439	7126	1430	335630	
	<b>Total</b>	<b>10366572</b>	<b>792797</b>	<b>3402968</b>	<b>594886</b>	<b>356647</b>	<b>15513870</b>	

high speed from high torque low speed by gear box. The motion is geared up and it runs the alternator at 1500-1600 RPM. Electricity in AC form from the connected generator output is converted to DC through a fully controlled converter. A control system either fuzzy logic based or a PID controller is used in a closed loop system to maintain the output from the converter at constant value. Battery is fed with the constant DC output from converter after the application of control action. Electricity can be stored in batteries for later use or can be directly coupled to load after conversion of DC voltage to AC voltage through inverter. This Bull powered generator is integrated with Photovoltaic system and diesel engine powered generator for continuous power supply. Control system also responds to the variations due to load and other integrated systems.

### 1.3 Software Simulation

It is predominantly seen that the platforms for experimental setups are costly and time consuming affairs. Computer simulation is a cost-effective and time saving procedure that can be employed for system design, optimisation, and control strategy and performance analysis prior to setting of experimental platform. This helps to predict the behaviour of real systems and can be modified if needed before implementation.

Simulation programs can be categorised into two groups such as dynamic models and static models. Dynamic models give the precise look at system operation and are used to empower the study of control strategies and power management. The static models are employed especially for economic analysis, performance predictions and for component sizing. Block oriented MATLAB Simulink is incorporated. Simulink is a graphical language developed by MATLAB. It is a multidisciplinary environment which provides simulation, analysing and modelling of dynamic systems. The main advantage of Simulink is that it has inbuilt library for various domains of science and engineering.

## 1.4 Objectives of Study

A Simulink realisation was undertaken. The aim of the system is to analyse the performance and design of the system through computer simulation and modelling before practical experiment. Particularly the objectives may be presented as follows:

- Feasibility analysis of draught animals
- Mathematical modelling using MATLAB Simulink
- Integration of various renewable energy systems for continuous power supply
- Development of the control system to provide stability for the integrated system

## 1.5 Outline of Thesis

**Chapter 1** Provides the introduction to the concept of micro integrated power system, motivation towards the system, need for simulation and objectives of study.

**Chapter 2** Presents a brief literature review of related work. **Chapter 3** Confers an experimental study of animal powered generator, discusses the draught animal power profiles and describes the component sizing and operation. **Chapter 4** Depicts the simulation and modelling of the system using MATLAB Simulink. **Chapter 5** Gives the results of simulation and discussion. **Chapter 6** We conclude the entire dissertation work.

## CHAPTER 2

### LITERATURE SURVEY

---

In the recent past an era of development of renewable energy sources has begun to meet the increase in energy demand and to reduce environmental damage. The availability of animal power and energy requirement of remote areas motivated various scientists, researchers and innovators towards the utilisation of animal power and integrated systems for power production. Some researchers have used an intermediate energy storage system such as battery bank, or hydrogen gas based fuel cell system. They have succeeded to utilise the animal power for power production with different methodologies such as, use of pressurised air to run the generator and most are with the traditional way of using animal power through circular motion to run the alternator. The relevant studies related to this field are presented in the following section:

Virk S. Jatinder [1] presented how animal power can be utilised to meet the problems of energy crisis as the traditional sources are depleting on higher rate. The Author also explained the need to use renewable sources of energy for generation of electricity mainly for the loads that are off grid or far from stations. As the demand of power is increasing that is putting more and more pressure on conventional sources for power generation. The Author presents an innovative idea to generate electricity for off grid stations using cattle power. The proposed design consists of a gear box, coupling shaft and a generator which can produce up to 300W. The whole method is completely renewable energy bases and is free from any kind of emissions. This unique aspect of cattle driven electric generator can be cost effective as compared to other conventional methods. The output as electricity from this system is sufficient to fulfil the demands of the farmer.

The Kanpur Gaushala Society [2] studied the increasing demand of electrical energy and focusing the areas of power crisis in India. The society reported the need of 24 hours electricity for the development of the country. The Poor availability of electric power in rural areas has inspired the society towards the invention of cattle driven electric generator. The Kanpur society in association with Durga engineering works developed the complete hardware for the cattle driven electric generator. This study also gives the comprehensive comparison between operating cost of the cattle

power generator and the diesel engine generator. The Diesel engine is very much costlier as the investment on cattle driven is very much negligible in comparison. For the generation of 1MW of electricity in case of diesel engine generator can cost up to 4 crore. Whereas the expense of producing electric power with the use of cattle power generator is negligible. One pair of bullock can charge two batteries of 12 volts each if they work for 3-4 hours. The cost of food for the cattle can be balanced by selling dung of the cattle. This can be used in compost or the urine in pesticides. This methodology can be useful as it is safe, maintenance free, low cost and eco-friendly.

The Vinayaka Energy Tech [3] is inspired after reading the use of animals in ancient books. The inspiration then leads him towards the design of animal driven power generation system to endure the needs of power in rural areas. As mainly the system is being installed for the use of household applications it can generate up to 2KW. This much power is sufficient for running 1HP tubewell pump which can provide up to 1500 litre per hour of water. The major components of the design includes a gear box is coupled with a permanent magnet generator and powered by pair of bullocks. By incorporating one more pair the system can be upgraded to produce 4KW. The obtained electric output from the system can be directly connected to load or can be saved in batteries. The system is maintenance free, low price and prolonged life.

Paras et.al [4] proposed a modified version of the traditional system of using animal power for generation of electricity. The proposed design uses a two stage conversion for generating electricity. Firstly the bull power is used to produce pressurised air which is then stored in the air tank. Further the stored air is used to run the air engine which ultimately runs the permanent magnet generator. This approach eliminates the use of storage battery as in case of the conventional system of power generation. The author focuses on the running cost to be negligible. The elimination of storage battery from the conventional system itself reduces the cost of RS 3,000-4,000 annually. The author unveils the tabular description of respective speeds, power outputs attainable from various draught animals. The author also talks about the feasible duration of time for which animals can work for an appreciable output i.e. 3-6 hours per day.

Fuller et.al [5] argues with the fact that the human and animal power should be included in the renewable sources mentioning that the efficiency can be increased with miscellaneous methods. According to him the animal and human power is probably

twice of wind power and approximately 13% of hydro power. The author discusses the contribution of power from traditional sources on global scale is nearly 17.9% for progressing countries and virtually 80% for small emolument countries. But there is still need to improve the supply for those which depends on conventional sources to improve their livelihood. The use of renewable sources should increase so to reduce the environmental damage and to proceed towards sustainable development. The author explores the premises that there are chances of minimising the plodding, improve health and income and to escalate skill levels either by upgrading the existing methods or by initiating new foot or hand powered technology for off grid stations. The author puts forward the case of animal and human power to be considered in the renewable source family. Tabular description of data for rural areas demonstrates the dominance of biomass energy as main energy source which supplies nearly 83%. From which the share of human and animal power is 12% of the total. From the total energy consumed the fossil fuel contribution is just 4% in rural areas. The force employed by the running animal is roughly equals to 10-12% of its existing weight. That means a buffalo has a power output of 300W or 5.4 MJ per day if it works for 5 hours per day. A 400Kg animal needs roughly 44MJ/d in food to be healthy and fit for work. Lastly the author concludes that there should be an investment towards human and animal power sources as they can proved to be cost-effective than various famous renewable technologies.

D.L.Soni [6] experimentally studied a hybrid power system synthesizing animal power and solar power to provide uninterrupted supply for home lighting system and other low power applications for off-grid stations. Animal power in form of high torque low speed is converted to low torque high speed through mechanical configuration to drive the electrical generator. The output can be saved in batteries and can be used for home lighting by converting direct current to alternating current using inverter. The photovoltaic powered system is the primary source whereas animal powered system is the secondary source which can be used when needed but mainly in absence of sunlight. The author also emphasises on the point that this system can work with or without the availability of sunlight. Due to this system there is decline in use of fossil fuels thus protecting environment from harmful effects. The author illustrates the configuration of solar panel installed i.e. 250W rated. Constant voltage of 12V has

been obtained with this system when the alternator reaches the ideal speed despite in variations of animal speeds. With the primary source the photovoltaic system battery can be charged in 7-10 hours considering the variations in temperature from morning to evening.

Gomez and Nacer [7] modifies the conventional method of using animal (horse) power. Electricity is generated in this design by increasing the rate of speed of an animal on a motor driven device indirectly or directly fastens to the hoof or variant part of the limbs of the source i.e. animal. The pressure put in by the muscle contraction of animal and force of gravity is used to make wheels spin in association with the electricity generator. Different configurations of gear segments are used to increase the revolutions per minute on the shaft of the alternator. The author reveals this system to be superior to treadmill based driven system. The author provides the diagrammatical description with all the required specifications of the system including the animal movement with all the limbs and foot link connections. According to the manifestation of this invention with the use of different gear segments 50 revolutions per second can be achieved. To generate one megawatt of electricity the proposed system is skilled by using multiple horses or various gear segments that results in increase of force, voltage and higher revolutions.

Udaysankar et.al [8] disclosed the process of converting the animal power to electrical or mechanical energy to be used in transportation of goods, people or other purposes. The configuration of this practice comprises of a chassis to accommodate to the animal at a fixed position. Several set of cranks, pedals for the accommodation of front and hind legs of the animal and various sets of cranks, pedals for the rider are installed to convert the animal power a to the power that will drive the alternator. A weight bearing machine is established to bear bulk of the weight with minimum weight on feet of the animal so to make pedalling easier for the animal against gravity. The author provides the schematically representation of the system from various angles. The pedalling and treadmill configuration can be used alternatively for animal cart. The existing mechanism can be modified with additional features like bicycle including braking, acceleration and suspension mechanism. This cycle mechanism can be powered with human, animal, electric or fuel powered. Successful transportation or electrical output has been obtained with this configuration.

Gokul Aashram [9] emphasises on the dependency of humans on animals and their need for food or transportation. The society is concerned about the reduced application of bull power due to invention and application of machinery in ploughing, electrical pumps or transport. A healthy bull needs continuous work and in absence of work farmers are left only with methods of reproduction that are also decreasing steadily. The society analyses the current situation of availability of electricity is worst in remote rural areas thus affecting the livelihood. Various government projects are planned but it takes several years for such projects and they require very huge investment. For such establishments land requirement is on higher level which causes significant migration of people. Most of them are nuclear or coal based resulting in environmental pollution. The design of this mechanism has a 15KVA unit that needs 4 bulls at one time for operation. 1MW of electricity can be obtained by using 6 such units of 15KVA capacity with required number of bulls. The society comparatively studies the installation or maintenance cost with the net saving using this same configuration. This process can be beneficial in producing electricity for 24 hours, employment for nearly 100 persons, and increase in cultivable land.

The society [10] designed the product to supply electricity in the most simple and sustainable way for localised remote areas. The output electricity can be utilized for home lighting, water lifting, battery charging and multimedia education for empowering villages with income generation. This approach has capacity to set off the revolution in the clean and green and can lead the country towards self-reliance. This technology can produce up to 30000MW of electricity for villages in remote areas. The society briefs about the contribution of animal power in national economy such as animal power contributes almost 50% of the total power consumed in farming sector saving diesel of approx. 21500 crore. It carries nearly 15% of the complete load transfer by transport sector. Animal power provides almost 100 million tons of dung yearly which can yield up to 5000 crore per year. Tabular representation of average power potential of animal has also been shown. With this conventional method for power generation using one pair of bullocks can light up to 40-50 CFL each of 20 watts and can be used for charging batteries.

The Rural technology action group (RuTAG), [11] IIT Delhi has experimented successfully to harness the animal power for sustainable agriculture. The group analysed

the benefit of draught animals to Indian agriculture as they can provide approximately 27 million Megawatts of electrical energy to Indian agriculture. The application of animal power is a tested process as a renewable source for sustainable agriculture so the group emphasises on the increase of usage of animal power in agriculture. The use of rotary mechanism for agricultural works can increase the on-going utilization of animal power. An animal driven prime mover configuration with step up gear segments driven by pair of bullock can be used as multi-purpose equipment for various other applications as well as water pumping, chaff cutting, castor, oil expelling, winnowing, etc.

Pathak et.al [12] has invented a device that powers a mechanical device for water desalination using animal power. The author reveals that this system is more than useful for obtaining clean drinking water from brackish salinized water. Animal power at high torque low speed is converted to low torque speed configuration using speed increaser to trigger the high pressure pump. The author emphasises on the main aspect of the conversion of animal energy to hydraulic energy. The reverse osmosis mechanism is applied for the conversion of brackish water to portable water. Efficiency of this mechanism is higher being a two stage conversion process in comparison to a conventional process which is a three stage conversion.

Agbossou et.al [13] depicts the necessity to increase the usage of integrated renewable energy systems for lighting remote stations. Generation of electricity is done with the integration of wind turbine and photovoltaic system. The process of electrolysis is used to produce hydrogen which is then stored when there is excess of power from renewable energy sources. When the power from the integrated systems is not sufficient electricity is then regenerated from stored hydrogen using a proton exchange fuel cell. This system prioritize the use to store excess energy from integrated systems in the form of hydrogen but not in batteries as they lose 1-5% of power per hour. Control algorithm composed of a dc bus and a power controller is applied which provides stability to the entire system. The fuel cell system being a highly efficient, clean, eco-friendly and a reliable system effectively produces output with efficiency better than 42% and power of average 4KW with favourable weather conditions.

Santarelli et.al [14] discussed the development of power systems on account of integration of renewable systems with utilization of hydrogen for storage purposes.

Three different systems have been installed for this process such as solar irradiance (from photovoltaic modules), hydraulic energy (from micro-hydro turbine), and wind energy (from micro wind generator). The important feature of this system is to supply power throughout a complete year of execution using the combination of hydrogen based energy system and battery bank (for short term power supply). Hydrogen powered system is used to support the three systems during the period when power from the renewable systems is not sufficient. Hydrogen based systems are preferred because of their higher efficiency because hydrogen can be directly feed to the fuel cell for electricity generation. A bus bar of 48V is designed in the system to distribute the electricity produced to the different components. A control system is used for the management during excess and lack periods of power. The control system functions by feeding power directly to inverter and in case of excess power firstly power is sent to the battery bank and then to electrolyser for hydrogen production. Graphically and schematically analysis has been done for all the three different systems.

Enjeti et.al [15] framed the approach to eliminate the abnormal harmonics of considerable magnitude being generated at input and output terminals of PWM based ac to dc converter. This control algorithm is introduced here to remove the lower order harmonics by assessing the components of unbalanced input power and adjusting the PWM gate signals accordingly. This procedure of eliminating harmonics offers various attributes such as high quality dc output and sinusoidal current at input with unity power factor. Due to such attributes ripples in current are reduced and reducing ac voltage distortion in the system contributing to a high improved performance. It is important to employ the control technique because remote electric systems are more prone to unbalanced voltages at instant of utilisation due to non-uniform distribution of single phase loads among three phases. A comprehensive mathematical modelling of PWM based ac to dc Converter has been provided with diagrammatic representation of input and output waveforms of converter.

Niketa et.al [16] aims to provide stability or voltage control for alternator with a fuzzy logic based voltage regulator. The terminal voltage tends to vary with the variation in alternator load due to the voltage drop in armature reaction and armature. This system works with processing of Voltage error by keeping a check on the difference between the rated voltage and generator output. The fuzzy logic based controller

is used to fix the output of generator to maintain it at a comparatively constant value by observing the difference between the output voltage and reference voltage. Mathematical modelling of alternator is done determining all the parameters and a hydraulic turbine is used as a prime mover for the alternator. Operator observation is used to analyze non-mathematical algorithm in fuzzy control based voltage control. The simulation is performed on MATLAB Simulink.

Majumder et.al [17] investigates various aspects of stability in microgrids for different microgrid applications. Microgrid consists of distributed energy resources integrated as a single energy system. The main focus of the author is to encircle stability criteria for remote connected microgrids depending on control strategy, ways of operation, network parameters, and sources for microgrid. Existing methods of microgrid stability are discussed with scope of improvements and different industry solutions. The traditional stability analysis of microgrids presented by the author facilitates a better way to implement micro source operation, frequency control, load shedding criteria, microgrid controller design and islanding procedure. The system stability depends on certain factors as control algorithm of the voltage source convertors, storage protection, compensation, micro sources etc. Block diagrams of various stability issues for different microgrids, methods of stability enhancement has been provided. Methods like Lyapunov function and P-V, Q-V curves are used for transient and voltage stability respectively. These investigations of stability are conferred with several control methods, time domain and Eigen value analysis to justify different aspects.

Kamel et.al [18] has developed a complete model to simulate the running performance of the microgrid. The development of microgrid helps to increase energy efficiency and reduce greenhouse gas. Different micro sources such as flywheel, micro turbine, two photovoltaic systems, solid oxide fuel system and a wind generator system all are integrated together as a microgrid. The author studied two cases, first to investigate running performance of microgrid when islanding occurs, second to investigate running performance when large power is exported by the microgrid to main grid. Micro sources are interfaced to microgrid using three different control strategies of inverter. First model is PQ, which controls the active and reactive power fed by inverter in to microgrid. The second model is PV model, which keeps the voltage of the inverter constant controls the active power. Third model is VF model, maintains the

frequency value within limits even after disturbances and keeps the voltage constant. Complete Simulink model is provided mentioning all different micro sources and their relation to different inverter based control techniques.

Most of the work that has been done so far is dedicated towards the generation of power or mostly storage of generated power. But control of output due to various variations such as variation due to load, due to variation of animal speed has not got sufficient attention. In this work, an effort has been made to provide stability to the entire integrated system by providing fuzzy logic based control strategy.



### CASE STUDY: EXPERIMENTAL STUDY ON ANIMAL POWERED MECHANICAL DEVICE FOR HOME LIGHTING SYSTEM

---

#### 3.1 System Description

Chandrakar et.al [19] imparts his concern over kerosene oil still being used for home lighting resulting in environmental pollution. He also talks about the need for renewable sources as generating power for off grid stations is a costly affair. As animal power is being used from the beginning of mankind the author puts forward the proposal of use of animal power for power generation. Tabular illustration of weight, output powers and speed for various animals is discussed.

The author used the idea of a device called Bellan to channel animal power Figure 3-1 to high torque low speed configuration. The design comprises of a speed increaser which consists four spur gear segments used to convert high-torque low-speed to high-torque low speed configuration.

As the animals are a great source even with low speed at least can efficiently provide electricity for 4 hours (6p.m.-10p.m.) with this design. This configuration comprises of:

- A high power Generator
- Speed Increaser
- Gears
- Belt and pulley transmission unit
- Lead-Acid automotive battery

In numbers there are 300 million draught animals and if we consider number of working animals the number may vary. There is an immediate need to look for renewable sources for power production as demand is increasing on a higher scale for which animal power utilisation is in focus. Animal power is comparable with tractor with efficiency of above 30% but due to waling and maintenance problems there efficiency may reduce significantly to nearly 10%. While this study indicates



**Figure 3-1:** Bull Powered Generator

utilisation of animal power is a complex task it may require human involvement for tasks such as milking, guiding, harnessing, and herding. A working animal can exert force approximately 10-12% of its weight. For example if the animal works for 5 hours per day we can have power output of about 300W or 5.4 MJ/d. Tabular representation Table 3.1 is provided which includes the speeds, output powers and the weights of different animals. The output from the animal may vary depending on certain factors such as malnutrition, difficult ground, stress, malnutrition etc. the most significant from them is poor nutrition because underfed, sick, unhealthy animals will not be able to provide acceptable output. Output can decline up to levels like 50% in buffalo and oxen.

**Table 3.1:** Animal speeds, Output powers and weight

Animal	Typical Weight KN (kgf)	Pull weight Ratio	Typical Pull N (kgf)	Typical working speed m/s	Power output W	Working Hours Per Day	Energy Output per day MJ
Ox(Bullock)	4.5(450)	0.11	500(50)	0.9	450	6	10
Buffalo	5.5(550)	0.12	650(65)	0.8	520	5	9.5
Horse	4.0(400)	0.13	500(50)	1	500	10	18
Donkey	1.5(150)	0.13	200(20)	1	200	4	3
Mule	3.0(300)	0.13	400(40)	1	400	6	8.5
Camel	5.0(500)	0.13	650(65)	1	650	6	14

Animal power in state of high torque low speed is transmitted to speed increaser using a device known as bellan which comprises of mechanical link and an external pipe for transmission. Speed increaser consists of on input shaft installed with 68 teeth

gear and one output shaft installed with 15 teeth gear for conversion of animal power which is in form of high torque low speed to low torque high speed. A belt and pulley system is for transmitting output from speed increaser in form of mechanical energy to generator. Further generator converts the mechanical energy from speed increaser to electrical energy. This study explores the argument that there are possibilities to reduce the drudgery, improvement in health, income and to raise the skill levels by introducing power production methods for remote areas. The author emphasises on animal power to be considered or recognised as member of renewable family and he worries about the animal energy to be used only for domestic and agriculture use and not for non-domestic applications.

### 3.2 Component Sizing

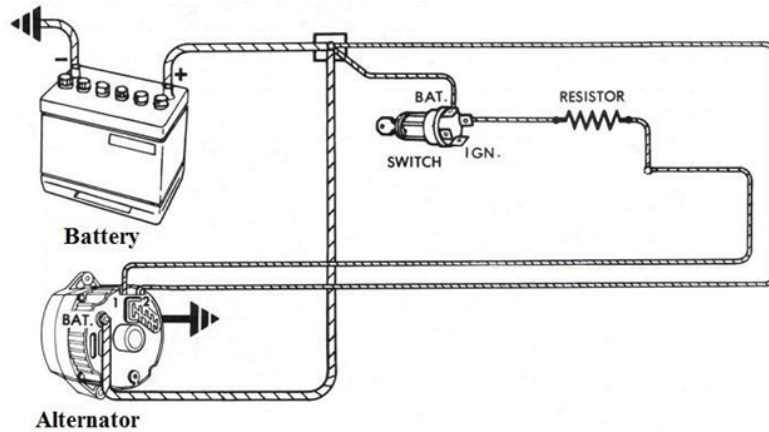

**Figure 3-2:** Components used in Bull Powered Generator

- Draught animal: The main aspect of this study is to utilise animal energy for power generation and the use animal power in agricultural works if from ancient times. The author uses two bullocks for study of this experiment of weights 456kg and 478 kg. The pair of bullocks pulls a device known as Bellan fitted with the mechanical link. Bellan is made of wood weighs about 105 kg. Figure 3-2

- Mechanical link: It is made up of mild steel with specifications of 230 mm length and 52 mm diameter with 3000 mm long strong GI pipe, thickness of 4.5 mm and is capable of transmitting animal energy to speed increaser. When animal powered bellan connected with mechanical link starts moving the mechanical link starts moving in 5m diameter circular path. With speed nearly of 60m per minute the bullock moves in the circular path. With bullock moving with the speed of 60m per minute completes one round of circular path powers the speed increaser with 3.8 revolutions per minute.
- Speed increaser: It is a set of four spur gears boarded in a frame of mild steel. Speed increaser has configuration of mild steel angles as 690mm 690mm at the top side and 780mm 780 mm at the bottom side. With gear ratios of 1:4:5 the speed increaser has 4 stages. The input shaft 1500mm length and is of 50mm diameter of mild steel material and output shaft of 1000m in length and having 50mm diameter. Speed increaser is specially installed to transfer animal power after conversion to high speed low torque to generator through mechanical link.
- Gears: For transmitting the power between parallel shafts four sets of gears are used which are made up of cast iron with module of 5mm. The spur gear has 68 teeth whereas 15 teeth for spur pinions (at output shaft). In a single stage of conversion the speed ratio of 1:4:5 is achieved.
- Belt and Pulley arrangement: This arrangement is used to increase the final speed. Speed can be increased up to ratio of 1:3 by boarding one pulley of 228.6mm on output shaft of the speed increaser and other counter pulley of 76.2mm on alternator. The belt selected is of A type belt according to Indian standard code having power ranges from 0.7KW-3.5KW.
- Generator: The car alternator of Lucas-TVS of 12V and 95Amp is used in this experimental for generation of electricity. Lucas-TVS alternator needs high rpm for better performance and it produces high current as RPM is high and produces constant voltage. The alternator rotor can rotate in any of the direction either in clockwise or in anticlockwise as the spin orientation of alternator has no effect on output power. The alternator must be connected to battery circuit for storage of output power. The circuit is shown below.

- Battery and storage application: A Rechargeable automotive battery Figure 3-3 of 12V, 150Ah is selected for storage process in this experiment. A lead-acid battery is selected. The time battery takes to charge depends on resting voltage and capacity of the battery.
- Home Lighting system: The main objective of this invention is to produce power for home lighting at remote rural areas and to reduce the consumption of kerosene. For the conversion of dc power to ac power a Microtek inverter of 750VA, 230V at 50 Hz is used. This system comprises of 6 CFL bulbs of 25 watt and 6 dc bulbs of 60 watt.



**Figure 3-3:** Battery and Alternator Connections

Animal speed is variable can change very quickly and it depends on the force applied by shepherd and load subjected. Due to this variability in speed as animals get puzzle the readings are taken with precision after every four minutes. Graphical representation of speed vs. time and speed vs. current shows the change in average speed of alternator and alternator producing high value of current after reaching ideal range of high RPM respectively. This study shows animals take little time to reach their average speed of 0.8 m/s to 1.0 m/s. When the animal reaches its ideal speed the alternator produces constant voltage of 12V. When 6 bulb of 60 watt Dc are loaded the battery takes approximately 2 hours to discharge 50% With inverter and battery efficiency of more than 80% for 4 hours per day (6pm-10pm) the home lighting is achieved.



## 4.1 Dynamic Simulation and Modelling

Distinctive modelling languages have been established over the recent time to facilitate simulation and modelling of various systems. There are specifically two different categories of languages in this domain namely block-oriented language and object oriented language.

Block-Oriented languages Figure 4-1 are widely used and popular. In such environments the blocks represent the system and the arrows the data flow. Mathematically, a block diagram relates to a system of ordinary differential equations in obvious form. The relationship of cause and effect is obvious in case of such ordinary differential equations. Input and state variables are used to define the output quantities.

The other class of language is object-oriented language in which the model emphasises on the interconnection various components of the system that has to be modelled. Depending on the objective to be achieved simulation models can be built and modify in many different ways. Important factors to be considered during simulation are:

- Level of generalization of the system is indicated from the step-time response of component models.
- Length of simulation running i.e. range of interest
- Supposition to be made e.g. factors influencing environment such as altitude, atmospheric pressure, ambient temperature etc.

The main focus of this work is to simulate control and power flow in a micro integrated power system. The time range is considered in between few seconds to several hours.

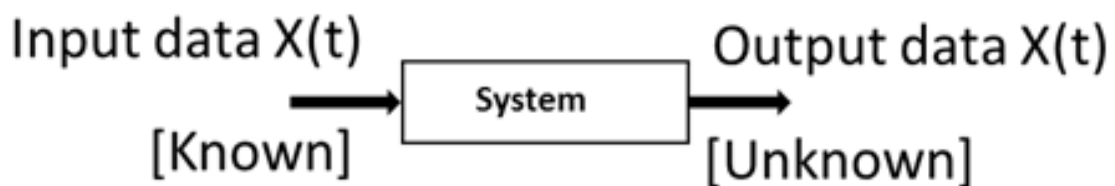

Figure 4-1: Block-Oriented data flow

The simulation consequently reduces to system level difficulty, where only the macroscopic behaviour of components is taken into consideration. This approach leads to a reasonable durations, which is always an issue with dynamic simulations. Internal component behaviour is not taken into consideration that means some physical quantities that rapidly changes are not modelled. Some of them are:

- The instantaneous magnitude of voltage and current on the 240 ac/50 Hz bus.
- The dynamics of power switches in converters
- Transients e.g. during the start of electric loads and inverters

## 4.2 Software Environment

Simulation and modelling of the micro integrated power system has been done using MATLAB Simulink. Simulink provides the medium as a graphical user interface for building block diagrams and models. We can view the system from outer higher level or can go down to see increasing levels of models by double clicking on the block diagrams. It is predominantly seen that the platforms for experimental setups are costly and time consuming affairs. Computer simulation is a cost-effective and time saving procedure that can be employed for system design, optimisation, and control strategy and performance analysis prior to setting of experimental platform. This helps to predict the behaviour of real systems and can be modified if needed before implementation. Simulation programs can be categorised into two groups such as dynamic models and static models. The static models are employed especially for economic analysis, performance predictions and for component sizing. Block oriented MATLAB Simulink is incorporated. It is a multidisciplinary environment which provides simulation, analysing and modelling of dynamic systems.

## 4.3 Simulation Models

Simulink blocks can be modelled as mathematical functions, look-up tables, or s-functions etc. The models that are measurement based are modelled in Simulink as look up tables. Models that are analytical or physical in nature are modelled as mathematical functions. The models that are combination of physical and practical

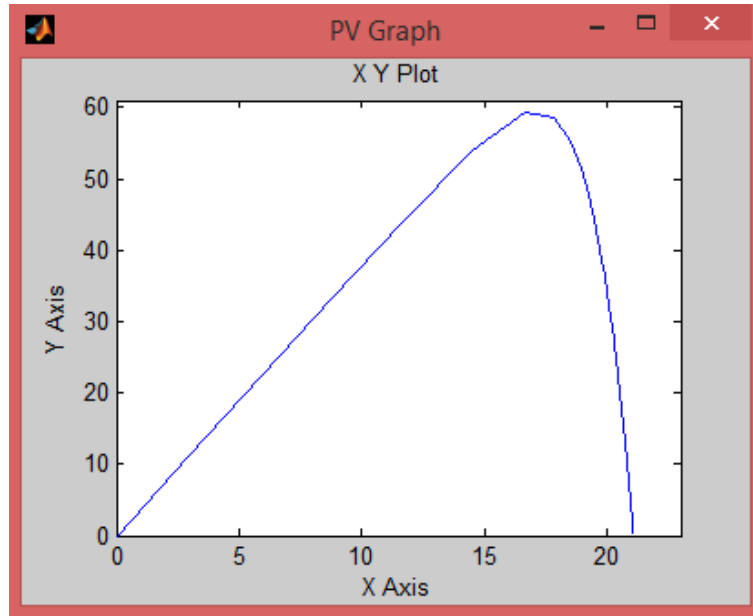

**Figure 4-2:** Intensity Variations

models including the control functions can be modelled as system functions. Some inbuilt blocks or libraries of Simulink are very slow to process. When they are used, the process of simulation is very slow. The system functions used in the Simulink can be compiled using visual C++ programming, which provides run time improvements.

### 4.3.1 Photovoltaic Generator

The precise knowledge of all the details of photovoltaic system is required to experiment the system in outdoor conditions. The main aim is to create a model where the independence between environmental conditions and the electrical parameters of a photovoltaic module is established Figure 4-2 4-3. Power outputs from photovoltaic systems can be predicted in spite of different weather, climates, or different seasons with the help of Simulink. Simulations are used to predict the amount of energy yield from the photovoltaic system.

### 4.3.2 Alternator

A machine converting mechanical energy to electrical energy by electromagnetic induction is known as electric generator. The word alternator Figure 4-4 comes from two words alternating and generator because a generator produces alternating cur-

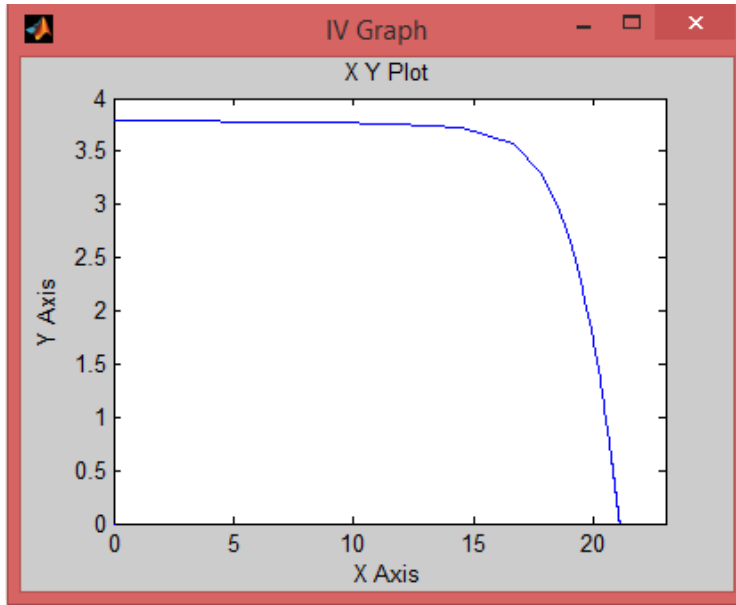

Figure 4-3: VI Characteristics of Photovoltaic Generator

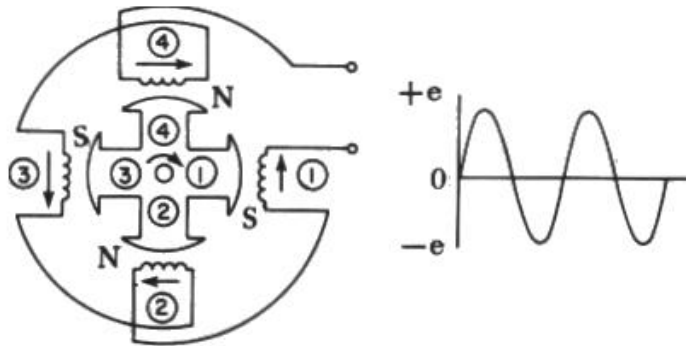

Figure 4-4: Single phase Alternator

rent. Most of the alternators uses rotating magnetic field with a stationary armature. EMF is produced due to relative movement of conductor with magnetic field. The reversal of polarity of EMF occurs when it moves under the magnetic poles that are of opposite polarity. The rotating magnet is known as rotor and an iron core that has set of conductors wound in coils known as stator. Generation of EMF results when field cuts across the set of conductors and the mechanical input causes rotor to run.

### 4.3.3 Converter

AC voltage is converted to DC voltage using single phase fully controlled converter. Four thyristors are applied to provide full control. Thyristors are the semiconducted

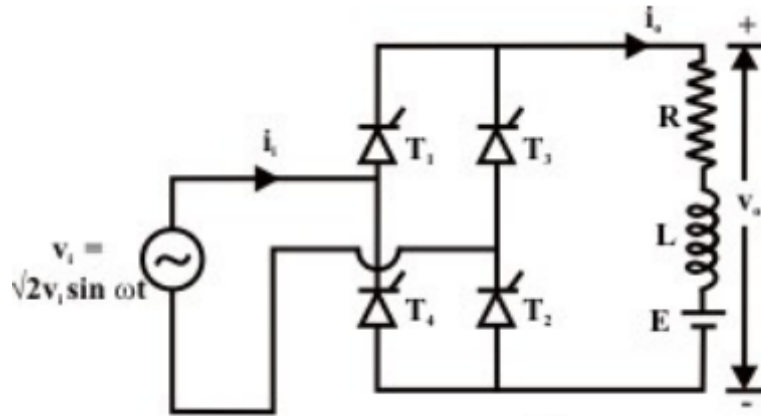

Figure 4-5: Fully controlled Converter

devices which can be turned on with application of current at its gate terminal. However, turning off of thyristors is not from the gate signals. Figure 4-5 The continuous exhibition of current waveforms and load dependent output voltage is same in both controlled and uncontrolled converters. The thyristors can block output voltage, forward voltage, or current magnitude can be controlled by controlling the firing angle of thyristors. Full Wave Bridge is most popular configuration used with the single phase fully controlled converters.

#### 4.3.4 Fuzzy Controller

Fuzzy logic based controllers are the non-linear type of controllers which uses linguistic variables. Fuzzy logic is swiftly becoming a feasible alternative approach for such conventional PID controllers. These controllers are becoming more and more attractive for solutions of real time control situations. . This control system is applied to achieve the stability of the whole integrated system. MAMDANI type of fuzzy inference system is used to implement the control strategy. This system works with processing of Voltage error and error rate by keeping a check on the difference between the rated voltage and generator output. Simulink provides the graphical user interface for the implementation of the fuzzy logic Figure 4-6. It is a very handy tool for the users. It provides an opportunity to define input and output variables and fuzzy logic in a single window. Figure4-7 The fuzzy logic based controller is used to fix the output of generator to maintain it at a comparatively constant value by observing the difference between the output voltage and reference voltage.

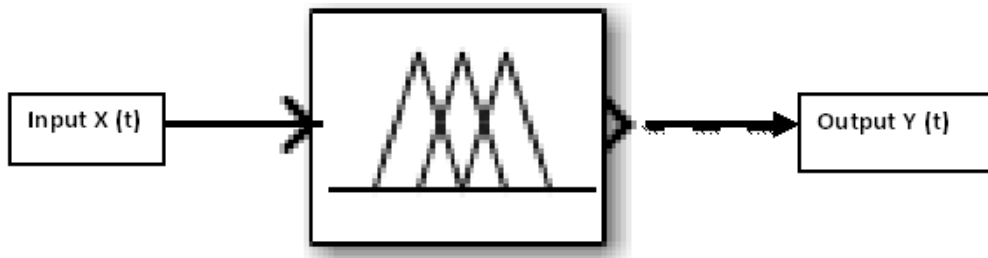

Figure 4-6: Simulink Block of Fuzzy Controller

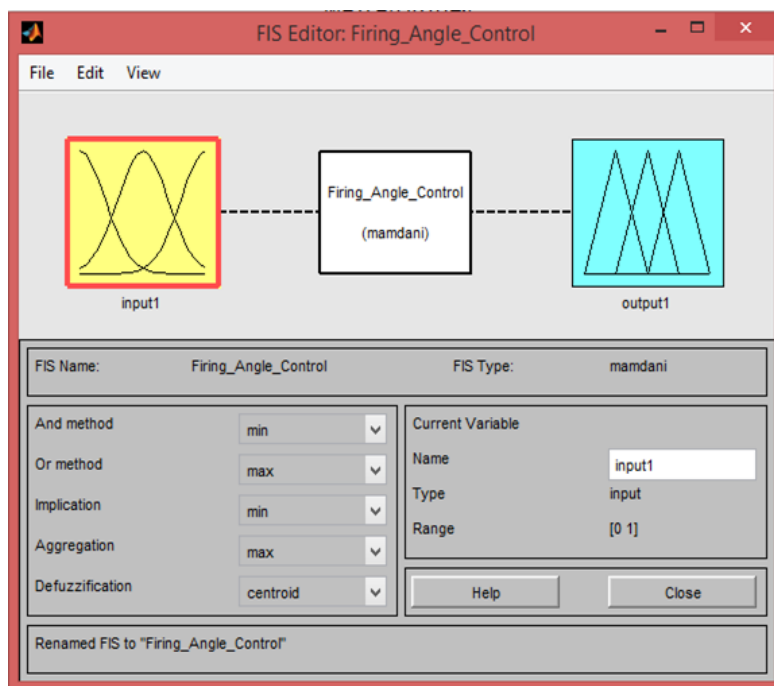

Figure 4-7: Fuzzy GUI

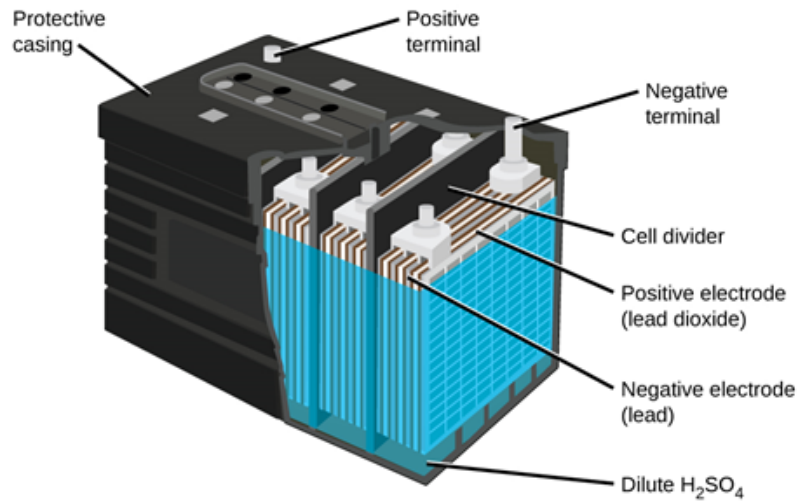

Figure 4-8: Battery

### 4.3.5 Lead-Acid Batteries

Lead-acid batteries Figure 4-8 comprises of flat lead plates submerged in pool of electrolyte. These batteries require regular water addition for proper functioning. Lead-acid batteries are made up of number of single cells that are connected in series with each cell producing approximately 2.1 volts. A 12 V battery consists of six Table 4.1 single cells producing an output voltage of 12.6 volts. Single cell of battery consists of a positive plate with a covering of lead dioxide paste and a negative plate that is made up of sponge lead and an insulating medium in between. The electrolyte is a mixture of water and sulphur in which plates are submerged after enclosing them in plastic battery case Figure 4-9. Each single cell has the capability of storing 2.1 volts.

Table 4.1: Battery Parameters

S.NO	Parameters	Rated Value
1	No. of cells	6
2	Nominal Voltage	12 V
3	Rated Capacity	150 Ah
4	Fully Charged voltage	12.6 V

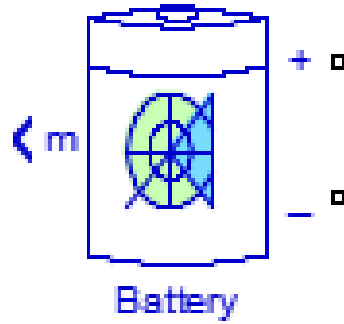

Figure 4-9: Simulink block of Battery

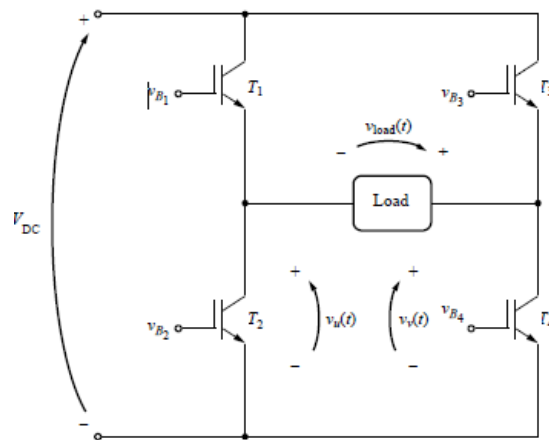

Figure 4-10: PWM based Inverter

### 4.3.6 PWM based Inverter Model

A PWM inverter Figure 4-10 changes states so many times during single cycle of resulting voltage at output. If the frequencies of 12 KHZ are used in PWM inverters, the components in the PWM inverter will change states nearly 24,000 times per second. Fast switching means PWM inverters need faster components with high frequency and high power. The components with high frequency and high power namely: IGBTs, GTO thyristors, and/or power transistors for exact operation. IGBTs have the upper hand due to features of high power switching, high speed, so they are preferred among all components for building PWM inverters.

Pulse width modulation is a technique of altering the width of pulses in a pulse train in proportion directly to a small control signal. More and more widely the resulting pulses become as greater the control voltage will hold. Sinusoid of the

desired frequency is used as the control voltage for PWM circuit. A two-level carrier-based PWM method is used. The comparison and sampling of the modulating signal is done using a symmetrical triangle carrier. Three different bridge type switching devices can be controlled by this block such as single phase full bridge, single phase half bridge.



## CHAPTER 5

### RESULTS AND DISCUSSION

Modelling and simulation has been done in MATLAB and Simulink. The main results are presented in the form of simulations of Battery voltage and AC Current. Bull power is geared up using gear box and is fed to alternator as mechanical input. The ac output from alternator is converted to dc voltage using fully controlled converter. The DC link is also supported by the photovoltaic array. The output DC voltage at DC link is maintained at constant value using fuzzy controller. The constant DC voltage is fed to battery bank for storage purposes. Which can be further connected to PWM based inverter for conversion of DC voltage to AC voltage to feed the AC loads Figure 5-3. The simulation results Figure 5-1 show the output at DC link Figure 5-2 remains constant at 23V (approximately) in spite of variations due to load, bull speed and output of PV array. Feasibility of integration of bull power with other renewable energy systems and control of DC output voltage using fuzzy controller is obtained in the present work.

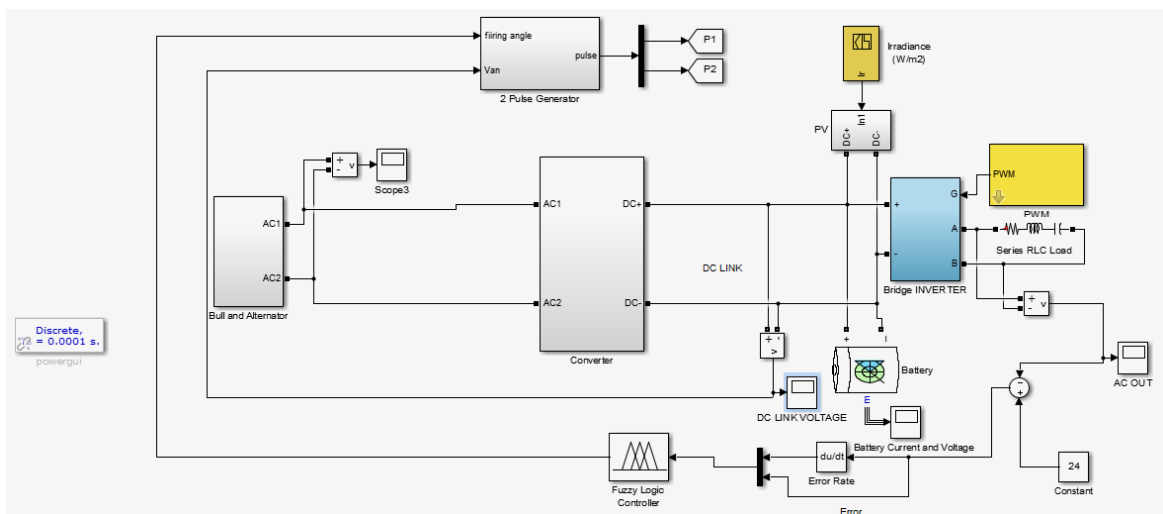
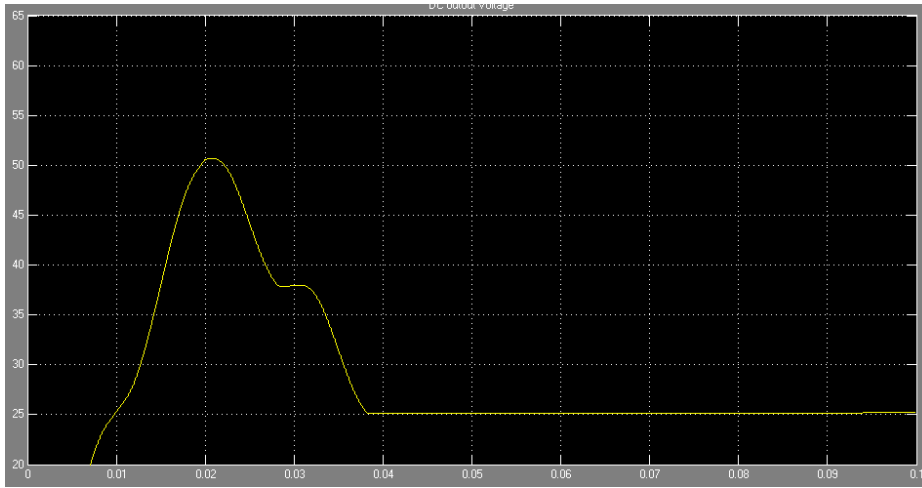
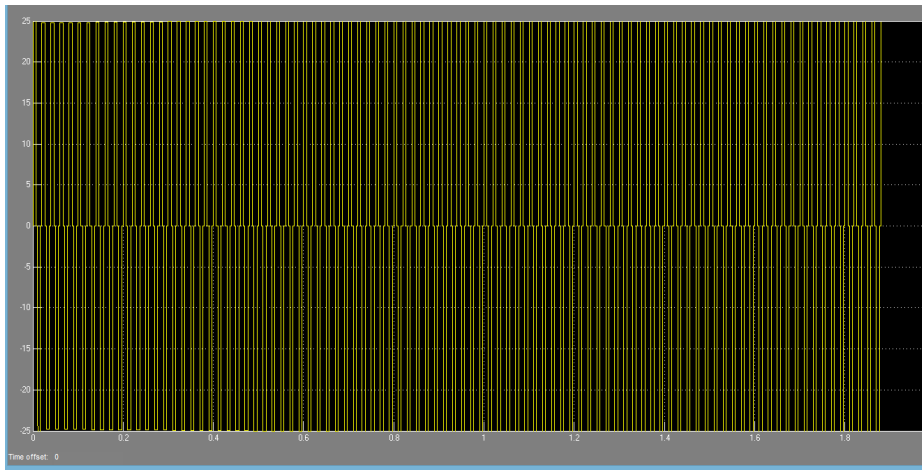

Figure 5-1: Simulink model of Complete Integrated System



**Figure 5-2:** Voltage of DC Link



**Figure 5-3:** Output AC voltage

## CHAPTER 6

### CONCLUSION

---

Simulation and Modelling is used to consider several feasible scenarios in a micro integrated power system designed for home lighting at remote locations. The main emphasis has been laid on the aspect of simulation.

1. Simulation results reveal that the animal power can be effectively integrated with other renewable energy systems.
2. Fuzzy controller can provide stability to the whole system by maintaining the dc link voltage at constant value.
3. The enite system is immune to several variations due to load and animal power.



## CHAPTER 7

### FUTURE SCOPE

---

*“To communicate the truths of the History is an act of Hope for the Future” -Daisaku Ikoda* The trend of providing power for remote locations using renewable energy systems is expected of gaining popularity. As renewable sources are on higher demand, therefore animal power can be considered as a potential source.

- The future scope of the present work includes in finding an efficient way to incorporate more and different animals to increase generation of power without affecting the cost
- Further the simulation results can be tested against the experimental results.
- There is also a possibility of integrating more such systems together to provide sufficient power for entire remote area.



## BIBLIOGRAPHY

---

- [1] virk jatinder singh, “alternator-the alternate way,” *Journal of electronics engineering*, vol. 4, no. 2, pp. 177–179, 2012.
- [2] Kanpurgaushalasociety, “Animal driven electrical generator cum battery charger.” [Online]. Available: <http://vinayakaenergytech.com/bullgenerator.html>
- [3] Vinaykaenergytech, “Bull driven generator.” [Online]. Available: <http://vinayakaenergytech.com/bullgenerator.html>
- [4] V. Paras, A. Chaudhary *et al.*, “Generation of electricity by utilization of power of draught animal,” *Indian Research Journal of Extension Education*, vol. 12, no. 2, pp. 150–153, 2016.
- [5] R. Fuller and L. Aye, “Human and animal power—the forgotten renewables,” *Renewable energy*, vol. 48, pp. 326–332, 2012.
- [6] D. Soni, “Electrical power uses for rural areas animal powered device hybrid with solar energy in place of conventional fuel,” *IJARSE*, vol. 4, no. 01, 2015.
- [7] M. Gomez-Nacer, “Animal powered electricity generator,” Mar. 24 2004, uS Patent App. 10/808,558.
- [8] U. Devanaboyina, “System for driving an animal powered vehicle,” Dec. 22 2011, uS Patent App. 13/159,434.
- [9] gorakshyamtrust, “ox powered electricity generator.” [Online]. Available: <http://www.gorakshyamtrust.org/project/ox-power-electricity-generator.html>
- [10] Udhyanbharti, “green power ruralportable generator.” [Online]. Available: <http://www.greenenergysolutions.co.in/ruralportablegenerator.html>
- [11] RUTAG, “Evaluation and standardisation of animal driven water pump.” [Online]. Available: <http://rutag.iitd.ac.in/rutag/?q=projects/animal-driven-water-pump>

- [12] N. Pathak, P. K. Ghosh, S. L. Daga, V. J. Shah, and S. N. Patel, “Animal powered mechanical device for water desalination,” Jun. 17 2008, uS Patent 7,387,728.
- [13] K. Agbossou, R. Chahine, J. Hamelin, F. Laurencelle, A. Anouar, J.-M. St-Arnaud, and T. Bose, “Renewable energy systems based on hydrogen for remote applications,” *Journal of Power Sources*, vol. 96, no. 1, pp. 168–172, 2001.
- [14] M. Santarelli, M. Cali, and S. Macagno, “Design and analysis of stand-alone hydrogen energy systems with different renewable sources,” *International Journal of Hydrogen Energy*, vol. 29, no. 15, pp. 1571–1586, 2004.
- [15] P. N. Enjeti and S. A. Choudhury, “A new control strategy to improve the performance of a pwm ac to dc converter under unbalanced operating conditions,” *IEEE transactions on Power Electronics*, vol. 8, no. 4, pp. 493–500, 1993.
- [16] N. Niketa *et al.*, “Design and modeling of fuzzy logic based voltage controller for an alternator,” 2013.
- [17] R. Majumder, “Some aspects of stability in microgrids,” *IEEE Transactions on power systems*, vol. 28, no. 3, pp. 3243–3252, 2013.
- [18] R. M. Kamel, A. Chaouachi, K. Nagasaka *et al.*, “Detailed analysis of micro-grid stability during islanding mode under different load conditions,” *Engineering*, vol. 3, no. 05, p. 508, 2011.
- [19] S. K. Chandrakar, D. L. Soni, D. K. Yadav, and L. K. Sahu, “Experimental study on animal powered mechanical device for home lighting system,” *International Journal of Environmental Engineering and Management*, vol. 4, pp. 471–482, 2013.

# Harpreet\_Thesis

## ORIGINALITY REPORT

15%

SIMILARITY INDEX

11%

INTERNET SOURCES

4%

PUBLICATIONS

6%

STUDENT PAPERS

## PRIMARY SOURCES

1	<a href="http://dahd.nic.in">dahd.nic.in</a> Internet Source	3%
2	<a href="http://www.ripublication.com">www.ripublication.com</a> Internet Source	3%
3	Submitted to Thapar University, Patiala Student Paper	3%
4	<a href="http://dspace.thapar.edu:8080">dspace.thapar.edu:8080</a> Internet Source	1%
5	Submitted to Universiti Teknikal Malaysia Melaka Student Paper	1%
6	Submitted to Visvesvaraya Technological University Student Paper	1%
7	Submitted to Jamia Milia Islamia University Student Paper	<1%
8	<a href="http://www.worldwideflood.com">www.worldwideflood.com</a> Internet Source	<1%
9	Leena, N., B. Durai Raj, and R. Gunabalan. "Computer-based laboratory teaching tools:	<1%

An overview of LabVIEW and MATLAB",  
2012 IEEE International Conference on  
Engineering Education Innovative Practices  
and Future Trends (AICERA), 2012.

Publication

---

- |    |  |      |
|----|--|------|
| 10 | Submitted to Bury College<br>Student Paper   | <1 % |
| 11 | Chandrakar, Sharad Kumar, D.L. Soni, D.K. Yadav, and Chandrashekhar Kurre.<br>"Experimental Study of Micro Industry of Animal Powered Mechanical Device for Battery Charging", Procedia Technology, 2014.<br>Publication | <1 % |
| 12 | Agbossou, K.. "Renewable energy systems based on hydrogen for remote applications", Journal of Power Sources, 20010601<br>Publication  | <1 % |
| 13 | file.scirp.org<br>Internet Source  | <1 % |
| 14 | Submitted to University of Newcastle upon Tyne<br>Student Paper  | <1 % |
| 15 | Submitted to Swansea Metropolitan University<br>Student Paper  | <1 % |
| 16 | cipit.org<br>Internet Source   | <1 % |
-

17	S.A. Choudhury. "A new control strategy to improve the performance of a PWM AC to DC converter under unbalanced operating conditions", PESC 91 Record 22nd Annual IEEE Power Electronics Specialists Conference, 1991 Publication	<1 %
18	Submitted to University of Johannesburg Student Paper	<1 %
19	Kamel, Rashad M., A. Chaouachi, and Ken Nagasaka. "Detailed Analysis of Micro-Grid Stability during Islanding Mode under Different Load Conditions", Engineering, 2011. Publication	<1 %
20	<a href="http://eprints.fbme.utm.my">eprints.fbme.utm.my</a> Internet Source	<1 %
21	<a href="http://www.coursehero.com">www.coursehero.com</a> Internet Source	<1 %
22	<a href="http://scholar.lib.vt.edu">scholar.lib.vt.edu</a> Internet Source	<1 %
23	<a href="http://ee.washington.edu">ee.washington.edu</a> Internet Source	<1 %
24	<a href="http://china-motor-company.com">china-motor-company.com</a> Internet Source	<1 %
25	<a href="http://www.actapress.com">www.actapress.com</a> Internet Source	<1 %

26

Giesselmann, Michael, Attila Karpati, István Nagy, Dariusz Czarkowski, Michael Ropp, Eric Walters, and Oleg Wasynczuk.  
"Inverters", Industrial Electronics, 2001.

Publication

<1%

---

EXCLUDE QUOTES OFF

EXCLUDE MATCHES < 7 WORDS

EXCLUDE  
BIBLIOGRAPHY ON