

Plant Classifier based on Leaf Shape and Texture features
*Thesis submitted in partial fulfillment of the requirements for the award
of degree of*

Master of Engineering
In
Computer Science

Submitted by:

Gaurav Suniara

(Roll No. 801532015)

Under the Supervision of:

Dr Rupali Bhardwaj
(Assistant Professor)



Computer Science Engineering and Department
Thapar University
Patiala – 147004

July 2017

Certificate

I hereby certify that the work which is being presented in the thesis report entitled, "**Plant Classifier based on Leaf Shape and Texture features**", submitted by me in partial fulfillment of the requirements for the award of the degree of Master of Engineering in Computer Science and Engineering at Computer Science and Engineering department of Thapar University, Patiala is an authentic record of my own work carried out under the supervision of *Dr Rupali Bhardwaj* and refers other researcher's work which are duly listed in reference section. The matter presented in this thesis has not been submitted for the award of any other degree of this or any other university.

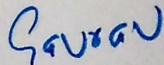
(Gaurav Suniara)

This is to certify that the above statement made by the candidate is correct and true to the best of my knowledge.

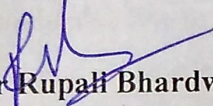
(Dr. Rupali Bhardwaj)
Assistant Professor
CSED, Thapar University
Patiala

Acknowledgement

I express my sincere and deep gratitude to my guide Dr Rupali Bhardwaj, Assistant Professor, Computer Science and Engineering and Department, Thapar University, Patiala for the invaluable guidance, support and encouragement. He provided me all the resources and guidance throughout the thesis work.

I am also thankful to Dr. Maninder Singh, Head of department, Computer Science and Engineering Department for his kind help and cooperation. I express my gratitude to all the staff members of Computer Science and Engineering Department for providing me all the facilities required for the completion of my thesis work.

I will be failing in my duty if I don't express my gratitude to **Dr. S.S. Bhatia**, Senior Professor and Dean of Academic Affairs, Thapar University, for making provisions of infrastructure such as library facilities, computer labs equipped with net facilities, immensely useful for the learners to equip themselves with the latest in the field.

I would also like to express my appreciation to my good friend for the timely motivation and providing interesting environment. It was great pleasure in working with them during the thesis work.

Last but not the least I would like to thank God and my parents for not letting me down at the time of crisis and showing me the silver lining of the dark clouds.

(Gaurav Suniara)

(801532015)

Abstract

The recognition of plants has become an active area as per the research many plants taxonomic group are at hazard of extermination. To preserve the endanger species new technique are been developed by the researchers. With the great advancement in the technology these days become the key factor for the identification the product and preserve that product with the help of mobile. The area of recognition of plants is trending nowadays because of the fact there are many more plant that need to be identify. More and more advancements are in progress to quickly and efficiently identify the plant. Today's world is all about speed and accuracy of the results. In this thesis, an efficient method of learning is used for the purpose of classification. In this thesis, we are using two approaches to identify the leaf and both approach consists of three Phases such as pre-processing, extraction of classification and execution phase. And of them first approach is shape based and second approach is texture based. The pre-processing phase involves a representation of image processing steps such as grayscale transformation and limits improvement. The main contribution of shape based approach is the probabilistic neural network (PNN) classification for the efficient recognition of the leaves whereas in texture based approach support vector machine (SVM) classify efficient recognition of leaves. In shaped based approach 13 sheet characteristics that they are extracted and orthogonalized into 6 main variables given as an input vector to the different methods and in texture based local binary pattern (LBP) use to extract features depending upon radius and nearest neighbour.

Table of Contents

Certificate	ii
Acknowledgement	iii
Abstract	iv
Table of contents	v
List of figures	vii
List of Tables	viii
Abbreviations	ix
Chapter 1: Introduction	01
1.1 Introduction	01
1.1.1 Why Plant Dataset	01
1.2 Why Plant Classification	03
1.3 Theoretical Framework	04
1.3.1 Acquisition of Leaf Image	05
1.3.2 Image Enhancement	08
1.3.3 A Segmentation Techniques	09
1.3.4 Extraction of Leaf Feature	10
Chapter 2: Literature Survey	12
2.1 Related Work	12
2.1.1 Work on Leaf Shapes	12
2.1.2 Work on Leaf Texture	16
2.1.3 Work on Both Shape and Texture	19
2.1.3 Other Related Work	19
Chapter 3: Problem statement	24
Chapter 4: Methodology	26
4.1 Software	26
4.2 Acquisition of Leaf Image	27
4.3 Image Leaf Segmentation	29
4.3.1 Units	30
4.3.2 Improvement of limits	30

4.3.3 Image Enhancement	32
4.4 Feature Extraction	33
4.4.1 Shape Based Approach	33
4.4.2 Texture Based Approach	35
4.5 Classification Based on Proposed Methods	37
Chapter 5: Experimental Results	41
5.1 Shape Based Approach	41
5.1.1 Accuracy Results	41
5.1.2 Execution time	41
5.2 Texture Based Approach	42
5.2.1 Accuracy of LBP	42
5.2.2 Execution time of LBP	43
Chapter 6: Conclusion and Future Scope	44
6.1 Conclusion	44
6.2 Future work	45
References	46
Current Proceeding	50

List of Figures

Fig 1.1: Commonly characterized leaf acknowledgment stages	06
Fig 1.2: Acer Palmaturu	06
Fig 1.3: Leaf database overview	08
Fig 4.1: Binary images	31
Fig 4.2: Chromosomal chains	31
Fig 4.3: Stem remove	32
Fig 4.4: Features	33
Fig 4.5: Represent major axis l and minor axis m of a leaf	34
Fig 4.6: Convex Hull	34
Fig 4.7: Shows the radius and number of points	36
Fig 4.8: histograms works	37
Fig 4.9: Process	37
Fig 4.10: Network Structure of PNN	39

List of Tables

Table 4.1: List of 1 st half species	28
Table 4.2: List of 2 nd half species	29
Table 5.1: Comparison of the classification of the Accuracy	42
Table 5.2: Comparison of the Execution time	42
Table 5.3: Comparison of the classification of the Accuracy	42
Table 5.4: Comparison of the Execution time	43

Abbreviations

PNN	Probabilistic Neural Network
SVM	Support Vector Machine
K-NN	K-Nearest Neighbor
LBP	Local Binary Pattern
OLBP	Orientation of the Local Binary Pattern
RBFINN	Radial Basis Function Network

1.1 INTRODUCTION

1.1.1 Why Plant Dataset.

Plants assume an indispensable part in the earth. There won't be presence of the environment of the land without plants. All things considered, recently, a few types of plants are at danger of annihilation. Keeping in mind the end goal to ensure plants and index species of diversity of flora, a database of plants essential.

There is an immense volume of plant species around the globe. Keeping in mind the end goal to oversee such volumes of data, the improvement of a quick and skilful arrangement procedure has turned out to be dynamic research. Likewise, together with the protection, the acknowledgment of plants has additionally been they are basic to adventure its medicinal properties and option wellsprings of vitality, for example biofuel. Exist different approaches to perceive a plant, such as flower, root, leaf, organic product and so on. As of late, PC vision and example acknowledgment methods have been connected to the automate acknowledgment of plants. The classification of the leaves of the plants is a chemical mechanism Flora and in drink and different manufacture.

In addition, the morphological characteristics of the leaves are for the classification of plants or for early diagnosis helps certain plants disorder. The identification of plants is a challenging task. Recognition of leaves [7] plays a role classification of the plant and it is a key problem lies in whether the characteristics are constant and have a good ability to discriminate various types of leaves. The recognition procedure is very timely consumer. Computer assisted plant acknowledgment is static very ambitious task in computer vision due to inefficient representation models and approaches. The main the objective of the plant recognition is to evaluate the geometry Morphological. This The data is very important to identify the different kinds of plants.

This work actualizes an algorithm of acknowledgment of simple to abstract features and high proficient acknowledgment algorithm. The fundamental segments of this research are: Extraction of characteristics and classification. All functions are Extracted from the digital

picture of the leaves. In shape based approach the classifier used in this Focus on Probabilistic neuronal network (PNN) [1] [4] [5] for its fast speed and improved recognition and in texture based approach classifier focus is on SVM [2] for simple and fast recognition.

Vision calculations have been actualized in lot of research zones, one of these territories are the agronomy one. The improvement of vision frameworks that naturally distinguish and recognize distinctive plants is a present test that has a few applications. These can extend basic ID, bother recognition, infections discovery, ID of plants by traditions staff, recognizable proof of a plant for care and security of pesticides, and so forth. As of late, advancement of programmed calculations to leaves recognizable proof has been guided by a few analysts. Be that as it may, plants distinguishing proof is not a simple employment, since plants recognizable proof include diverse issues, for example, leaf highlights; the immense measure of various plants; many plants have as well as offer at least one properties, for example, shape, estimate, surface, shading, notwithstanding when they are distinctive plants, a few attributes like shading and surface in plants leaves are altered by the development of the leaves, mugginess, maladies, and so on. In most recent couple of years, analysts have created diverse procedures to distinguish plants from takes off. A large portion of these frameworks have concentrated on acquiring geometric, textural and chromatic, elements to distinguish takes off.

This exploration has been persuaded of these disservices. The proposed calculation utilizes a hereditary calculation to get the most accommodating characteristics for arrangement's precision. The proposed calculation lessens the commotion acquainted with the classifier with the element dimensionality. The proposed method exploits from the hunt limit of the hereditary calculations, this pursuit is guided utilizing distinctive execution measurements. Gotten exploratory outcomes demonstrates that proposed calculation can enhance execution of the classifier.

In Agriculture, vegetables plants have turned into a vital wellspring of vitality and wellspring of living of Filipino ranchers. Effectively distinguishing a vegetable leaf enables agriculturists to separate between vegetables and also a vegetable seedling and weed in the garden. With such a variety of assortments of verdant greens originating from our neighbourhood ranchers every week, it can be hard to make sense of which will be which. In spite of the fact that these leaves may seem comparative initially, they are very one of a kind fit as a fiddle, Texture and Color. What's more, with the expanding utilization of imaginative PC innovation, digitalized

ways have turned into a probability for plant distinguishing proof. There is an instrument in programming that have the capacity to build up a framework where, simply having a picture, can perceived a picture and match it with the data in the database. This device may explain a case in deciding effectively the vegetables right through the photo of their leaves and it is called picture handling. Picture handling is a strategy to change over a photo into cutting edge casing and play out a couple of operations on it, remembering the true objective to get an updated picture or to focus some supportive information from it. It is a kind of banner allocation in which data is picture, like video packaging or photograph and yield may be picture or properties related with that photo. For the most part, Image Processing system consolidates viewing pictures as two-dimensional signs while applying formally set banner taking care of methodologies to them. With the assistance of picture preparing, engineers' can now do investigate consider wherein it includes design acknowledgment and programmed arrangement devices that will decide the types of the subject. What's more, Leaf Recognition is currently rising for research purposes.

1.2 Why Plant Classification.

Leaf acknowledgment innovation assumes an essential part in plant order and its key issue lies in whether chose elements are steady and have great capacity to segregate various types of clears out. It is notable that the right approach to concentrate plant highlights includes plant acknowledgment in light of leaf pictures. Specifically, ID process is done by social event leaves segregated from the plants, treated and recolored preceding the imaging. The initial step of the calculation is the seclusion of the leaf by thresholding. In the accompanying, the picture is changed from RGB to dim scale and continues to the strategy for removing and coordinating. The fundamental target of the review, A leaf recognition of plants utilizing Matlab, is to make an informative plant's leaf recognition utilizing Matlab to help the ranchers, botanist and agricultural researchers in distinguishing a vegetable and its regular points of interest in an advantageous and dependable way. For the particular goals, scientists thought of the accompanying: to investigate the periods of which the picture leaf experience; to configuration leaf recognition that can decide the plants personality through their Leaves; to code a leaf recognition utilizing Matlab as the essential dialect; to test the program to figure the precision and dependability of the framework; and to execute a framework that may help

understudy specialists. This review covers mechanized distinguishing proof of a leaf of plants as it were. To be particular, the caught picture of a leaf will experience through picture handling in the propose framework and in few moments, it gives the consequence of what sort of plant is the leaf. Some portion of the outcome would likewise comprise of the plants' common name, description. For the restriction, the leaf recognition may experience issues in perceiving a picture where position and point of the picture is not settle with the arrangement of criteria in taking the photograph. What's more, quite possibly the program won't ready to perceive a leaf that has a harm part. Additionally, the review concentrates just to the set number of plants. This review exhibited by the scientists to profit the botanist researchers even standard individuals in perceiving a plant through a picture of its leaf in a less demanding and a proficient way and future specialists in their own particular scholastic works and can contribute in the building up their own framework. The review is likewise open for improvement.

1.3 Theoretical Framework

PC Vision is the train of extricating data from pictures, inverse of computer graphics. There is a cover with Image Processing in regards to essential systems, and a few creators utilize both terms conversely. The fundamental objective of computer vision is to make models and concentrate information and data from pictures, while picture processing is about applying changes to the pictures, for example, differentiating, among others. The accompanying area clarifies the diverse computer vision methods and concentrates identified with leaf acknowledgment to date. Most creators separate the leaf acknowledgment handle in into five stages [4] leaf picture procurement, picture improvement, picture division, leaf highlight extraction, also, delineates these five stages and their relating items. Human capacity to perceive any question in a picture, paying little heed to how these items are put some time recently, is one that we people underestimate. For a machine, in any case, questions that been meant another position in the picture, pivoted or scaled up or down speak to totally new protests. All together for a machine to perceive the two questions as being comparative, calculations should be produced that can effectively accommodate protest id paying little heed to where they are situated in the picture or whether they are scaled or pivoted. Plants assume a basic part on human life. This part incorporates nourishment, solution, industry and condition. The earth has an enormous number of plant species and in this way id of every

species is hard. A snappy and precise acknowledgment and recognizable proof of a plant is fundamental for researchers in the territory of horticulture, organic science and condition. Plant species distinguishing proof has been done by botanists and plant pro for a long time utilizing distinctive plant highlights like leaf shapes, fruits, blossoms and shading.

Plants assume a basic part in safeguarding the fragile adjust of the earth. Sadly, the staggering improvement of human progress has upset this parity to a more prominent degree than we understand. It is one of our greatest duties to spare the plants from different dangers, re-establish the assorted qualities of the plant group and set everything back to adjust. A mechanized plant recognizable proof framework can be extremely useful in greenhouse or common save stop administration, new plant species revelation, plant scientific classification, colourful plant recognition, consumable/harmful plant ID et cetera

1.3.1 Acquisition of Leaf Image

Leaf Data

Existing database of leaf acknowledgment normally utilize pictures of single leaves on a consistently hued foundation, which makes it less demanding to distinguish the leaf. For example, the creators of Leaf Snap utilize Expectation-Maximization method to bunch pixels process into leaf or non-leaf classifications, yet this must be done if the picture is as of now arranged with a uniform foundation. There are few open data for leaf acknowledgment, however none has turned into a generally acknowledged by the visionary computer people group yet. The accompanying is the

Leaf Image Acquisition
<ul style="list-style-type: none"> • Fresh leaf images with uniform background
Image Enhancement
<ul style="list-style-type: none"> • Images with noise and artifacts removed • Images converted to other color domains
Leaf Segmentation
<ul style="list-style-type: none"> • Leaf pixels separated from background pixels
Leaf Feature Extraction
<ul style="list-style-type: none"> • Curvature • Shape • Texture
Similarity Search / Species Classification
<ul style="list-style-type: none"> • Supervised Machine Learning Classification (kNN, PNN, SVM)

Figure 1.1: Commonly characterized leaf acknowledgment stages



Figure 1.2: *Acer palmatum*

most widely known as:

The Swedish Dataset comprises of fifteen species with seventy five pictures. Pictures are adjusted to diminish revolution. Just a single side of the leaf is caught. This picture dataset offers high between species likeness.

Flavia Dataset contains 3,621 leaf with 32 species pictures with white foundations. This data utilizes new leaf snapshot.

Image CLEF 2013 incorporates 250 types of trees and herbs from France. It incorporates pictures of leaves, blossoms, natural products, stem and the entire plant. It involves both pictures with white foundation and pictures taken specifically in the field (new test leaves) with complex foundations, commotion and lighting. In past, a long-time other comparable dataset was likewise accessible.

Database Description

The present database includes 40 non-identical plant species. Elements of every plant's scientific name and quantity of leaflet examples accessible by species. Species number from 1 to 15 what's more, from 22 to 36 display straightforward fond and generation number from 16 to 21 and also 37 to 40 have complex structure of leaves. Each leaf example was captured over a shaded foundation. The 24-bit RGB pictures recorded have a determination of 720x920 pixels. Parallel variants are accommodated straightforward takes off.



Figure 1.3: Leaf database overview

1.3.2 Image Enhancement

When pictures are obtained, the following stage comprise of pre-processing the picture to upgrade vital elements. This progression incorporates dark scale change, commotion lessening and other shading area transformations. The objective is to erase undesired commotion what's more, bends that may influence the accompanying stages.

Gray scale Conversion transforming the picture to dim scale powers is extremely normal, since a large portion of the component extraction strategies work better on dark scale. To change over a RGB (Red Green Blue) picture to gray scale.

Leaf/Non-Leaf Validation Some investigations additionally created versatile applications amid their look into, to give clients the alternative to catch a leaf picture progressively. By enabling the clients to transfer pictures, another issue emerges which comprises of recognizing if the picture has a leaf inside by any means, to stay away from additionally preparing for

invalid images. Hence, creators have prepared classifiers, for example, SVM [2] (Support Vector Machines) to recognize if there is a leaf inside the caught picture. In database a poor dimensional portrayal of the given scene utilizing A poor dimensional portrayal of the given scene, which does not require any type of division descriptors utilized as list of capabilities.

1.3.3 A Segmentation Techniques

Once database is made, the pictures cleaned, and the commotion is sifted through, the subsequent stage is to remove the leaf from the picture [17]. Most examinations manage clean leaf pictures, with uniform foundations, and utilize shading bunching strategies to separate the leaf.

Thresholding A parallel picture is the consequence of changing over an ordinary picture to a two-esteem picture (ordinarily highly contrasting, or when all is said in done two hues just) [19]. A few thinks about utilize procedures that require twofold pictures, particularly for shape [1-6,8-9,14-16] and texture [10,12,13,17,18,19] extraction.

Desire Maximization it is an iterative calculation used to discover the most extreme probability appraisals of parameters when the model relies on upon in secret inactive factors [15]. It bunches the pixels into two gatherings: leaf pixels and non-leaf pixels. Connected to leaf division in [1-6], it is utilized with the accompanying numerical models Chart Cut Very couple of studies manage a leaf dataset that has complex foundations or, then again uncontrolled conditions, for example, light, commotion, and different questions inside the picture. A few issues emerge from complex foundation pictures [14], for example, on intelligent frameworks, for example, portable applications, the calculations must be quick.

Compound leaves are amazingly hard to fragment because of their mind-boggling division limits. Leaf pictures display common varieties in lighting, which makes shadows that include clamour contemplate how a semi-controlled light condition influences conventional bunching calculations to remove the leaf from the picture given that it produces undesired shadows. They pick to perform shading grouping, as on their past work, trailed by a Graph-Cut (otherwise called Min-Cut), which finds the worldwide ideal division arrangement. It depends on the possibility that that a chart can be divided in two disjoint sets by just evacuating edges interfacing them both. It is imperative to take note of that this strategy does not manage any uncontrolled situation, but rather just with semi-controlled lighting settings.

1.3.4 Extraction of Leaf Features

When leaf pictures are perfect and leaf pixels have been separated, the subsequent stage is to remove a list of capabilities of the leaf that is sufficiently discriminative to decide its species. A large portion of the element extraction strategies specified in writing depend on various morphological qualities by utilizing PC inspirational strategies [1-5]. Some utilization shapes or form [1], others surface [19], and even shading [5,7,11] and texture [10,12,13]. Leaves as a rule display no less than two favourable circumstances over blossoms and organic products when it comes to programmed species order. As a matter of first importance, they are two dimensional. Also, they are accessible amid all year. Since we utilize surface extraction in this exploration, we should take note of the surface has diverse implications in Botany and PC inspirational. In Botany, surface can be characterized as the physical surface of the leaf, which means how it feels against class. In PC inspirational notwithstanding, the meaning of surface contrasts since it is the example of non-uniform spatial dissemination of various imaging forces [11]. In this examination, we utilize the PC Vision definition, as we are searching for pixel examples and relations between them. Once the district has been portioned its elements are separated. Highlight extraction enables us to speak to the picture utilizing an arrangement of numerical esteems with high discriminative power, wiping out excess elements and lessening the dimensionality of the picture. The attributes acquired can relate fundamentally the same as reaches to comparable pictures, relate diverse extents to various pictures, the components got are invariant to scaling, revolution and interpretation, empowering the classifier to perceive objects notwithstanding having distinctive size, position and introduction. Every one of these elements assume an essential part in the calculation execution and enable the classifier to separate between various classes in a proper way. More profound data regarding the matter can be found in [2,10].

Geometric Features Geometric components are the most crucial and used visual components to aggregate plants. The key geometric qualities delineate the basic properties of the region to see, these are; zone, roundness of the leaf edge, length of the leaf, expansion described by the length and width of the leaf, x and y bearings of the gravity centre, thickness, portrayed by the length of the edges of the leaf. Nevertheless, a beneficial course of action structure should allow to see leaves paying little notice to their presentation, territory and size, i.e. it must be invariant to scaling, upheaval and exchange.

Textural Features The extraction counts of textural highlights scan for key dull cases with irregular or self-assertive structures in pictures. These structures offer climb to a property that may be fineness, smoothness, et cetera. Since a repeat a case along a surface are invariant to expulsion, this elucidates why the visual impression of a surface is free of the position. These extractors consider the dissemination of drive regards in the region, by getting the mean and extent of the going with factors.

Chromatic Features Chromatic components give information of the shading energy of a divided district. These traits can be determined for each power channel, for example, red, green, blue, grayscale, tone (Hue), (Saturation) and drive (Value), et cetera.

2.1 Related Work

The segment recaps past work on the leaf acknowledgment utilizing computer inspiration strategies. It involves a few works applying strategies for leaf include extraction and picture arrangement.

2.1.1 Work on Leaf Shapes

[1] Stephen Wu and Forrest Bao state that utilize PNN with picture and data taking care of frameworks to realize an extensively helpful mechanized leaf affirmation for plant arrange. 12 leaf highlights are isolated and orthogonalized into 5 essential components which contain the data vector of the PNN. The PNN is set up by 1800 leaves to portray 32 sorts of plants with a precision more significant than 90%. Differentiated and different methodologies, our estimation is a correct synthetic mental ability approach which is fast in execution and straightforward in utilization.

[2] Arunpriya and Balasaravanan state that unique—recognition of plants has turned into a dynamic territory of look into as the vast majority of the plant species are at the risk of disposal. This paper uses a viable machine learning approach for the request reason. This proposed approach contains three phases, for instance, preprocessing, incorporate extraction and portrayal. The preprocessing stage incorporates a normal picture get ready strides, for instance, changing to dull scale and point of confinement change. The part extraction arrange construes the typical DMF from five key segments. The essential duty of this approach is the SVM arrange for capable leaf affirmation. 12 leaf highlights which are evacuated and orthogonalized into 5 basic elements are given as data vector to the SVM. Classifier attempted with flavia dataset and a veritable dataset and differentiated and k-NN approach, the proposed approach makes high precision and takes less execution time.

[3] Manisha Amlekar state that plants are especially noteworthy segment of biological community. Plants can be utilized as foodstuff, in meds and in numerous businesses for

assembling different items. Recognizing those guarantees the assurance and survival of all characteristic life. Plant distinguishing proof can be performed utilizing a wide range of procedures. As plant leaves are all the more promptly accessible, it is proficient to distinguish and arrange plants by utilizing their clear out. Plant arrangement by utilizing leaves requires distinctive biometric highlights. This paper introduces the audit on different techniques for plant grouping in view of leaf biometric highlights. For plant characterization customarily, the prepared taxonomist and botanist had required to perform set of different assignments. The taxonomist as a rule arranges the plants in light of blossoming and acquainted wonder. It was discovered that this procedure was tedious and troublesome for following different undertakings. The biometric components of plants leaf, for example, shape and venation make this characterization simple. This audit study may help the rustic individuals for effortlessly recognizing notwithstanding characterizing the plant in view of the leaf highlights. This plant characterization strategy incorporates two essential undertakings leaf biometric include extraction and grouping of plants in view of these components.

[4] Boran Sekeroglu, Yucel Inan state that leaf acknowledgment has been picked up a significance since the augmentation of astute applications in various stages, for example, desktop and portable. Each leaf contains special unmistakable example on it that gives viable contribution to neural systems keeping in mind the end goal to perceive the kind of the leaf effectively. In this paper, smart acknowledgment framework is exhibited to perceive and recognize 27 unique sorts of leaves utilizing back engendering neural system and results demonstrate that the created framework is better than late inquiries about with the better acknowledgment rate

[6] Trishen Munisami, Mahesh Ramsurn state that robotized frameworks for plant acknowledgment can be utilized to group plants into proper scientific classifications. Such data can be helpful for botanists, industrialists, nourishment designers and doctors. In this work, an acknowledgment framework equipped for recognizing plants by utilizing the pictures of their leaves has been created. A portable application was likewise created to enable a client to take pictures of leaves and transfer them to a server. The server runs pre-preparing and include extraction methods on the picture before an example matcher contrasts the data from this picture and the ones in the database so as to get potential matches. The distinctive elements that are separated are the length and width of the leaf, the territory of the leaf, the edge of the leaf, the body range, the structure edge, a separation outline the vertical and even tomahawks, a shading histogram and a centroid-based outspread separation delineate. A k-Nearest

Neighbor classifier was executed and tried on 640 leaves having a place with 32 distinct types of plants. An exactness of 83.5% was gotten. The framework was additionally improved by utilizing data acquired from a shading histogram which expanded the acknowledgment exactness to 87.3%. Besides, our framework is easy to utilize, quick and profoundly versatile.

[8] Patil Bhagya, Anupama Pattanshetty and Suvarna Nandyal state that plant species grouping utilizing leaf tests is a testing what's more, critical issue to tackle. This paper presents another informational index of sixteen specimens each of one-hundred plant species; and depicts a strategy intended to work in conditions of little preparing set size and potentially fragmented extraction of components. This spurs a different preparing of three component sorts: shape, surface, and edge; consolidated utilizing a probabilistic system. The surface and edge highlights utilize histogram amassing, while a standardized depiction of form is utilized for the shape. Two beforehand distributed strategies are utilized to produce isolated back likelihood vectors for each component, utilizing information related with the k-Nearest Neighbor device. The joined back assessments create the last arrangement (where missing components could be precluded). We appear that both thickness estimators accomplished a 96% mean exactness of order when consolidating the three elements in this route (preparing on 15 tests with inconspicuous cross approval). Furthermore, the system can give an upper bound of the Bayes Risk of the characterization issue, and along these lines evaluate the exactness of the thickness estimators. In conclusion, the superior of the technique is shown for little preparing set sizes: 91% exactness is seen with just four preparing tests.

[9] Akhil Arora, Ankit Gupta state that programmed plant identification assignments have seen expanded enthusiasm from the machine learning group as of late. This paper portrays their cooperation in the Plant Identification Undertaking, sorted out by combined lab evaluation forum where the test was to identification plant generation in view of leaf snapshots. Wrest order the different sorts of pictures and afterward utilize a assortment of novel pre-processing techniques, for example, shadow and foundation revision, petiole evacuation and programmed leaf division for distinguishing the leaf blobs. We next utilize complex system structure alongside novel tooth recognition strategy and morphological operations to process a few helpful elements. At long last, we utilize some arbitrary backwoods for classification. In view of the proposed approach.

[14] Pushpa BR, Anand C and Mithun Nambiar P state that programmed acknowledgment of plant species acknowledgment is a testing issue in the zone of example acknowledgment and

PC vision. A productive plant acknowledgment framework will be gainful to numerous divisions of society which incorporates restorative field, botanic looks into and plant scientific categorization think about. Manual distinguishing proof process requires earlier information and furthermore it is a extensive process. This paper proposes a straightforward and proficient approach for Ayurvedic plant arrangement utilizing advanced picture preparing and machine vision innovation. The three real stages in proposed system are pre-handling, include extraction and arrangement. Pre-handling is done in request to highlight the significant elements to be utilized as a part of the proposed technique and also to lessen undesirable clamor from the information picture, which diminishes the shot of getting ideal element esteems. In include extraction stage, diverse morphologic components, for example, mean, standard deviation, arched body proportion, isoperimetric remainder, whimsy and entropy are removed from the pre-handled leaf picture. In the third stage, another way to deal with characterize ayurvedic plant species is received to perceive plant species by figuring the leaf factor of the info leaf utilizing the extricated include qualities and it is contrasted and the prepared esteems that are put away in the database. An awesome exactness is gotten for the proposed approach.

[15] Wang, Chi and Feng displayed a proficient two-organize approach for leaf picture recovery by utilizing basic shape highlights including centroid-form separate bend, flightiness and point code histogram . The erraticism of a protest can speak to the worldwide shape include for coarse recovery and is straightforward for ordering. Then again, the edge code histogram is received for portraying nearby elements, (for example, swells) of plant takes off. It has been exhibited that these components are interpretation invariant and centroid-form separate bend can accomplish scaling and pivot invariance subsequent to being standardized and adjusted at beginning stages. Our approach has been tried on 1400 leaf pictures with sensibly great outcomes.

[16]. Hassan Hajjdiab and Iman AI Maskari exhibited a PC vision based strategy to perceive plants utilizing the shape of the plant clears out. The form of a leaf first is removed at that point handled and a component 'Vector is defined. The element 'Vectors are put away in a database to be utilized for recognizing plants in the worksite. A picture of the leaf is in the first place sustain to the PC, the element 'Vector is then removed from the leaf and the species is distinguished by coordinating the leaf highlight vector with the component vectors put away in the database. Probes 10 leaf shapes have been directed to test the technique on leaves of diverse shapes and sizes. The primary favourable position of our proposed technique is that

exclusive form components are utilized as a part of the coordinating procedure, the strategy is scale invariant and computationally effective.

[20] R.Janani and A.Gopal state that recognizable proof of appropriate restorative plants is very testing and it is an ideal opportunity to secure therapeutic plants since a few plant animal types are getting to be noticeably wiped out. Leaves are the key segments of a plant. Here we have proposed a technique for the extraction of shape, shading and surface components from leaf pictures and preparing a fake neural system classifier to identification the correct leaf class. The key issue lies in the choice of legitimate picture input elements to accomplish high productivity with less computational multifaceted nature. We tried the precision of the system with various mix of picture highlights. The test comes about on 63 leaf pictures uncovers that this strategy gives awesome precision with at least eight information highlights. This approach is all the more encouraging for leaf distinguishing proof frameworks that have least information and request less calculation time. This work has been executed utilizing the picture handling and neural system tool compartments in MATLAB.

2.1.2 Work on Leaf Texture

[10] Arun, Sam Emmanuel and Christopher state in this paper displays a mechanized framework for perceiving the restorative plant leaves that are taken from suburbia of the western ghats areas. The information incorporates 250 particular leaf pictures, of five species. Surface examinations of the leaf pictures have been done in this work using the component count. The components consolidate dim surfaces, diminish tone spatial dependence systems and LBP (Local Binary Pattern) overseers. For each leaf picture, a component vector is created from the quantifiable regards. 70% of the photos in the dataset are the get ready dataset and the rest are fused into the test set. Six particular classifiers are used to orchestrate the plant leaves in view of incorporate esteems. Right when highlights are joined with no pre-preparing, it yielded a decent portrayal execution.

[12] Anant Bhardwaj, Manpreet Kaur and Anupam Kumar state given paper displays an essential and computationally incredible procedure for plant species affirmation using leaf pictures. Affirmation of plant pictures is one of the examination purposes of PC vision. The usage of shape for seeing items has been adequately considered since the begin of question affirmation. A couple of makers suggest that challenge shape is more instructive than its appearance properties, for instance, surface and shading vary between question events more

than the shape. At to begin with, we have separated leaf pictures which are two dimensional in nature and divided the photos by logical morphological division and after that removed the high repeat highlight of picture. For clearing the clutter, the photo has been changed over into parallel, at that point supplemented and expanded by filtered picture. We quantitatively set up the usage of surface for distinguishing proof diverse leaf pictures of same tree that are troublesome by other built up procedures for picture planning. Energize we use Nearest Neighborhood arrange strategy to describe plant leaf. In this paper we focuses essentially on picture change, picture division, high repeat highlight extraction, upheaval remove from establishment, volume part, speak differentiate minute, minute invariant and morphological segment, for instance, an area convexity.

[13] Rashad, Desouky and Khawasik state that paper presents an method of plant grouping which depends on the portrayal of surface properties. We utilized the joined classifier learning vector quantization. We arbitrarily took out 30 squares of every surface as a preparation set furthermore, another 30 hinders as a testing set. We found that the consolidated classifier strategy gave an elite which is a prevalent than other tried strategies. The test comes about showed that our calculation is appropriate and its normal rectify acknowledgment rate was incredible.

[17] Nanni, Iamini and Brahmam state the point of this work is to locate the most ideal route for portraying a given surface utilizing a LBP based approach. Initial a few diverse methodologies are looked at, at that point the best combination approach is tried on various datasets and contrasted and a few methodologies proposed in the writing (for reasonable correlations, when conceivable we have utilized code shared by the first writers). Our trials demonstrate that a combination approach in view of uniform nearby quinary design and a turn invariant nearby quinary design, where a container choice in light of fluctuation is performed and Neighborhood Preserving Embedding include change is connected, acquires a strategy that performs well on all tried datasets. As the classifier, we have tried a remain solitary help SVM and an irregular subspace troupe of SVM. We look at a few surface descriptors and demonstrate that our proposed approach combined with irregular subspace outfit beats other late cutting-edge approaches. This conclusion depends on broad examinations led in a few areas utilizing six benchmark databases.

[18] Ferrer, Morales and U.Pal state that script recognizable proof is an essential stride in multi-script archive examination. As different surfaces show in content fragment of a script are the

guideline unmistakable segments of the script, in this paper, we proposed another count for printed script recognizing evidence in perspective of surface examination. Since neighborhood plans is a uniting thought for ordinary truthful and assistant strategies of surface examination, here the basic idea is to use the histogram of the close-by cases as portrayal of the script stroke orientation dissemination which is the typical for each script. As close-by illustration, the basic adjustment of LBP and a changed variation of OLBP are proposed. The arrangement has been affirmed on two databases. The first or get ready database is a database with two hundred sheets of ten particular scripts. The scripts content style is given by the translator. The second or test database has been gotten by analyzing unmistakable day by day papers and books. It contains five fundamental scripts among ten extraordinary scripts of the chief database. From the examination, we procured enabling happens.

[19] T.Ojala, Matti Pietkanien and Topi Maenpaa state in this paper introduces a hypothetically extremely straightforward yet effective approach for dim scale and turn invariant surface grouping in light of neighborhood paired examples and nonparametric separation of test and model conveyances. The proposed approach is exceptionally powerful as far as dim scale varieties, since the administrators are by definition invariant against any monotonic change of the dim scale. Another favourable position is computational effortlessness, as the administrators can be acknowledged with a couple of operations in a little neighbourhood and a query table. Amazing trial comes about acquired in two genuine issues of turn invariance, where the classifier is prepared at one specific pivot point and tried with tests from other revolution edges, show that great segregation can be accomplished with the measurements of basic turn invariant nearby twofold examples. These administrators portray the spatial arrangement of neighborhood picture surface and the execution can be additionally enhanced by joining them with pivot invariant change measures that describe the difference of nearby picture surface. The joint dispersions of these orthogonal measures are appeared to be intense devices for revolution invariant surface examination.

2.1.3 Work on Both Shape and Texture

[5] Abdul Kadir, Lukito Edi Nugroho state that a few strategies to recognize plants have been proposed by a few scientists. Regularly, the strategies did not catch shading data, since shading was not perceived as an imperative viewpoint to the ID. In this examination, shape and vein, shading, and surface elements were joined to group a leaf. For this situation, a neural system

called Probabilistic Neural system (PNN) was utilized as a classifier. The test result demonstrates that the technique for arrangement gives normal precision of 93.75% when it was tried on Flavia data, that it contains 32 sorts of different plant takes off. It implies that the strategy gives better execution contrasted with the first work.

[7] Mallah, Copes and Orwell state that plant species grouping utilizing leaf tests is a testing what's more, critical issue to tackle. This paper presents another informational index of sixteen specimens each of one-hundred plant species; and depicts a strategy intended to work in conditions of little preparing set size and potentially fragmented extraction of components. This spurs a different preparing of three component sorts: shape, surface, and edge; consolidated utilizing a probabilistic system. The surface and edge highlights utilize histogram amassing, while a standardized depiction of form is utilized for the shape. Two beforehand distributed strategies are utilized to produce isolated back likelihood vectors for each component, utilizing information related with the k-Nearest Neighbor device. The joined back assessments create the last arrangement (where missing components could be precluded). We appear that both thickness estimators accomplished a 96% mean exactness of order when consolidating the three elements in this route (preparing on 15 tests with inconspicuous cross approval). Furthermore, the system can give an upper bound of the Bayes Risk of the characterization issue, and along these lines evaluate the exactness of the thickness estimators. In conclusion, the superior of the technique is shown for little preparing set sizes: 91% exactness is seen with just four preparing tests.

[11] Thibaut Beghin, James S Cope state in this paper displays a novel strategy for arrangement of plants utilizing their takes off. Most plant species have one of a kind leaves which contrast from each other by qualities, for example, the shape, shading, surface and the edge. The technique acquainted in this investigation proposes with utilize two of these elements: the shape and the surface. The shape-based technique will separate the form signature from each leaf and after that compute the dissimilarities between them utilizing the Jeffrey-disparity measure. The introductions of edge angles will be utilized to investigate the full-scale surface of the leaf. The consequences of these strategies will then be consolidated utilizing an incremental grouping calculation.

2.1.4 Other Related Work

[21] Sapna Sharma, Chitvan Gupta state that it is a testing undertaking to examine plant leaf pictures by a layman in light of the fact that there are exact moment varieties in a few plant

leaf pictures and bigger informational collection for investigation. It is a very hard to build up a robotized acknowledgment framework which could handle on a substantial data and give a right estimation. Fake neural systems have been effectively connected to issues in design acknowledgment, order and picture examination. In the paper, multilayer energize forward frameworks are readied using back spread learning figuring. The guideline objective of this paper is to develop a portrayal system for agriculture and ayurvedic plants by picture pre-get ready, leaf frame, incorporate extraction, mastermind get ready and portrayal. In our proposed count, we attempted 440 leaves of different 16 classes and the system yields.

[22] C.S.Sumathi, A.V Senthil Kumar state that an electronic strategy for perceiving plant leaf in view of their pictures is proposed. Plant characterization depends on leaf ID which has wide application on inevitable in arrangement and cultivation. Plant leaf pictures contrasting with six plant sorts are taken using an automated camera which are broke down using three different exhibiting strategies, first in perspective of MLP (Multi-Layer Perceptron) Neural framework and second on NCS-FNN (Normalized Cubic Spline Feed Forward Neural framework) and third on proposed NCS-FNN for veritable data. Relationship based component assurance is considered to make a situated once-over of characteristics. Matlab is used to isolate the leaf components, for instance, edge and surface. Edge and surface are the basic visual characteristic which can be used to delineate the pixel relationship in a photo. Further to construct the precision in NCS-FNN the neural framework is readied using a back spread regulate by back causing bungles and changing weights of center point. The dataset contains 197 pictures which are apportioned into six classes.

[23] Hassan Hajjdiab and Iman AI Maskari state that plants significantly affect human's life and advancement. Plant species recognizable proof is fundamental for researchers working in the rural and ecological fields. Perceiving an animal groups is not a paltry assignment because of immense amount of plant generations that exist on earth. This paper can introduce a PC inspiration based procedure to perceive plants utilizing the shape of the plant takes off. The shape of a leaf initially is removed at that point handled and an element vector is figured. The component vectors are put away in a database to be utilized for distinguishing plants in the worksite. For a researcher to perceive a plant, a picture of the leaf is first nourish to the PC, the component vector is then separated from the leaf lastly the species is recognized by coordinating the leaf include vector with the element vectors put away in the database. The adequacy of the proposed technique is shown by a trial.

[24] Laura D. Jalili, Alfredo Morales state that the advancement of vision frameworks to plant leaves recognizable proof from pictures is a critical current test. One of the fundamental lines of research is the change in execution. The execution of programmed ID frameworks is straightforwardly connected to the separated highlights. The extricated highlights permit to distinguish or characterize the question. Be that as it may, once in a while a high number of elements presents commotion which influences the execution. In this exploration, a hereditary calculation is proposed to extricate the most discriminative components. The proposed strategy diminishes the dimensionality of the informational collection and enhances the execution to distinguishing plants. In the test comes about, the proposed strategy is contrasted and include choice exemplary strategies. Test comes about demonstrate that the proposed method gets a huge change in the execution in correlation with different strategies.

[25] Bernhard E. Boser state that in preparation calculation that expands the edge between the preparation designs and the choice limit is introduced. The procedure is proper to a wide collection of the gathering limits, including perceptrons, polynomials, and radial basis functions. The convincing number of parameters is adjusted normally to organize the versatile nature of the issue. The arrangement is communicated as a straight mix of supporting examples. These are the subset of preparing designs that are nearest to the choice limit. Limits on the speculation execution in view of the forget one strategy and the VC-measurement are given. Trial comes about on optical character acknowledgment issues show the great speculation acquired when contrasted and other learning calculations.

[26] Chaki ,Jyotismita, Parekh, Ranjan state in this paper proposes a mechanized framework for perceiving plant species in view of leaf pictures. Plant leaf pictures comparing to three plant sorts, are investigated utilizing three diverse shape demonstrating procedures, the initial two in view of the M-I (Moments-Invariant) display and C-R (Centroid-Radii) demonstrate and the third in light of a proposed method of B-S (Binary-Superposition). For the M-I demonstrate the underlying four central institutionalized minutes have been considered. For the C-R exhibit an edge marker has been used to recognize the breaking point of the leaf shape and 36 radii at 10-degree dapper division have been used to create the shape vector. The proposed approach includes taking a gander at parallel versions of the leaf pictures through superposition and using the total of non-zero-pixel estimations of the resultant as the segment vector. The enlightening record for experimentations involves 180 pictures parceled into get ready and testing sets and connection between's them is done using Manhattan, Euclidean what's all the more, crossing point measures. Exactnesses got using the proposed framework

as far as anyone knows is a change over the M-I and C-R based frameworks, and commensurate to the best figures declared in surviving written work.

[27] Sethulekshmi A V, Sreekumar K state that there are a ton of procedures pertinent for the reason mechanized leaf acknowledgment for plant grouping. Numerous calculations have been presented in the previous decade and accomplished great execution. Endeavors have centered upon numerous different fields however properties of elements have not been well researched. A gathering of elements is chosen ahead of time however vital element properties are not very much used to highlight choice. In this paper the execution of various elements extraction strategies are thought about, various blends of highlights and various classifiers connected for leaf recognizable proof process are additionally talked about.

[28] Hammel, Prusinkiewicz, and Wyvill proposed a technique for displaying compound of leaves in the plants. The design of leaf projections is caught by a spreading skeleton created utilizing a L-framework. The leaf edge is then followed around the skeleton. At last, the surface limited by the edge can be twisted and supplemented with an alleviation, if these elements are found in the genuine leaf. The paper concentrates on the determination and following of the edge, and incorporates references to the strategies depicted in the writing for playing out alternate assignments. The edge is characterized as an understood form — a one-dimensional partner of verifiable surfaces utilized already in PC designs. All through this paper, leaves were seen as two-dimensional surfaces. In all actuality, they are three-dimensional articles, and at any rate at the veins, their thickness is not unimportant. Demonstrating slight articles utilizing verifiable surfaces is an open issue, albeit a few outcomes toward this path have been acquired.

[29]. Yan , Zheru , and Feng built up an intuitive apparatus which makes a difference botanist to separate the vein framework with its various levelled properties with as meagre client connection as would be prudent. In this paper, another venation extraction technique utilizing autonomous part examination. Another preferred standpoint of vein highlight extraction is that an herbal understanding of leaves needs the information to be in a shape that permits correlations between diverse tree takes off. The prevalent and productive Fast ICA calculation is connected to patches of leaf pictures to take in an arrangement of direct premise capacities or elements for the pictures and after that the fundamental capacities are utilized as the example outline vein extraction. In this investigation, the preparation sets are haphazardly produced from various leaf pictures. The preparation set comprised of haphazardly produced

50,000 12x12 pixel patches from 12 sub-pictures, taken from 21 sorts of tree leaf pictures. Trial comes about exhibit that ICA is a promising method for separating leaf veins and edges of items. ICA, in this manner, can assume an essential part in naturally distinguishing living plants.

[30] Naoufel Werghi, Stefano Berretti and Alberto del Bimbo state in this paper, we display a novel and unique structure, which we named work nearby double example LBP, for figuring neighborhood paired like-designs on a triangular-work complex. This system can be adjusted to all the LBP variations utilized in 2D picture examination. All things considered, it permits stretching out the related methods to work surfaces. Subsequent to depicting the establishments, the development and the principle components of the work LBP, we infer its conceivable variations and show how they can expand the vast majority of the 2D-LBP variations to the work complex. In the analyses, we give confirmation of the nearness of the consistency viewpoint in the work LBP, like the one seen in the 2D-LBP. We likewise report repeatability tests that affirm, specifically, the turn invariance of work LBP descriptors. Besides, we break down the capability of work LBP for the errand of 3D surface grouping of triangular-work surfaces gathered from open informational indexes. Correlation with cutting edge surface descriptors, and additionally with 2D-LBP partners connected on profundity pictures, likewise proves the viability of the proposed structure. At last, we delineate the power of the work LBP concerning the class of work anomaly run of the mill to 3D surface-digitizer checks.

[31] T.Ojala, M.Pietkainen and T.Maenpaa recently a hypothetically exceptionally straightforward, yet productive, multiresolution way to deal with dark scale and revolution invariant surface order in light of nearby twofold examples and nonparametric segregation of test and model circulations. The technique depends on perceiving that specific nearby double examples, named "uniform," are major properties of neighbourhood picture surface and their event histogram is ended up being an effective surface component. We determine a summed up dark scale and turn invariant administrator introduction that takes into consideration identifying the "uniform" examples for any quantization of the exact space and for any spatial assurance and presents a methodology for joining different managers for multiresolution examination. The proposed approach is to a great degree intense with respect to dull scale assortments since the manager is, by definition, invariant against any monotonic change of the diminish scale. Another good position is computational ease as the director can be recognized with two or three operations in a little neighborhood and an inquiry table. Trial

comes to fruition show that incredible isolation can be proficient with the occasion estimations of fundamental rotate invariant neighborhood.

Chapter 3 Problem Statement

Herbaria keep a lot of dry and mounted specimens of the existing plants to help logical investigate. As verified that once a leaf come to its final stage of dry and also mounted, some natural qualities of a leaf, for example, shading might be lost, however vein designs are kept in place. Veins will likewise tend to emerge much more than typical. Besides, leaf dataset has roughly 200 plant species. The species distinguishing proof prepare is manual, moderate, repetitive, and mistake inclined. There have been pioneer endeavours to mechanize the ID procedure with lessened areas [4; 24], in any case none has been tried. Super differing locales, for example, the Neotropic require apparatuses to recognize both known and obscure species in a proficient, programmed or self-loader path, so as to better comprehend and ration the world biodiversity.

The leaf dataset is collected then using MATLAB to create and calculate the features of the processed leaf image then after dataset of features is calculated and then organised families of the plant data set is use by the approach methods PNN, SVM, k-NN to get results.

Chapter 4 Methodology

This part covers the procedures, instruments and analysis configuration utilized as a part of this examination. Manual undertakings, for example, picture digitalization of new caught leaves from the field were required for the reference dataset. Programmed species recognizable proof calculations required programming improvement errands. Procedure of proposed framework is appeared in Fig. 4.1. Initial steps are normal in any arrangement of acknowledgment from attributes. In tests, geometric and textural highlights were gotten. Because of space conditions, it is quickly characterized the means that are basic in order frameworks and furthermore are connected by proposed technique. In the first place, the pictures are pre-prepared and portioned. Self-ruling division is a standout amongst the most troublesome undertakings in picture handling. In pictures of leaves, regularly they are encompassed by greenery out of sight. Notwithstanding, the pictures utilized, were leaves absolutely in a controlled situation (pictures with just leaf and white foundation). Division tests were finished utilizing versatile fringe division calculations and division utilizing a period of central part examination and no contrasts between them were gotten by the idea of the dataset, so at long last calculation was utilized for division.

4.1 Software

So as to execute the models for machine learning tools and the LBP model, we made utilization of a few existing libraries. By utilizing existing usage, we decreased advancement time and enhanced the execution's heartiness. The accompanying is a rundown of the key libraries utilized for this exploration:

Photoshop CS: Utilized Photoshop to physically tidy the leaf snapshot. And cleaned Background, shadows, clean, and any undesired protest or clamour from all pictures. This procedure was connected to a segment of the dataset, not to everything, keeping in mind the end goal to encourage leaf division. This application is not open source.

MATLAB (Matrix Laboratory): Matlab plays an important role in this experiment or implementation of the paper. Matlab provides large number of inbuilt models and algorithms and to save our time on implementing and writing full code all by us, because sometime

writing difficult code turn out to be more time consuming and headache job, therefore Matlab provide us the safe platform to execute our problem and get our results.

4.2 Acquisition of Leaf Image

A key component to this exploration was the securing of leaf pictures. Since for old data there was no appropriate dataset with uniform foundations that we could utilize, so we look for more database. Moreover, to quantify the viability of modular and flow in addition to surface approach, we likewise required datasets to benchmark our discoveries. For benchmarking we utilized the leaf dataset.

Class	Scientific Name
1	<i>Quercus suber</i>
2	<i>Salix atrocinera</i>
3	<i>Populus nigra</i>
4	<i>Alnus sp.</i>
5	<i>Quercus robur</i>
6	<i>Crataegus monogyna</i>
7	<i>Ilex aquifolium</i>
8	<i>Nerium oleander</i>
9	<i>Betula pubescens</i>
10	<i>Tilia tomentosa</i>
11	<i>Acer palmatum</i>
12	<i>Celtis sp.</i>
13	<i>Corylus avellana</i>
14	<i>Castanea sativa</i>
15	<i>Populus alba</i>
16	<i>Acer negundo</i>
17	<i>Taxus bacatta</i>
18	<i>Papaver sp.</i>
19	<i>Polypodium vulgare</i>
20	<i>Pinus sp.</i>

Table 4.1: List of 1st half species.

Class	Scientific Name
21	Fraxinus sp.
22	Primula vulgaris
23	Erodium sp.
24	Bougainvillea sp.
25	Arisarum vulgare
26	Euonymus japonicus
27	Ilex perado ssp. azorica
28	Magnolia soulangeana
29	Buxus sempervirens
30	Urtica dioica
31	Podocarpus sp.
32	Acca sellowiana
33	Hydrangea sp.
34	Pseudosasa japonica
35	Magnolia grandiflora
36	Geranium sp.
37	Aesculus californica
38	Chelidonium majus
39	Schinus terebinthifolius
40	Fragaria vesca

Table 4.2: List of 2nd half species

4.3 Image Leaf Segmentation

With a specific end goal to dispose of a few elements that don't add to the classifier execution, in this exploration, a hereditary calculation was utilized to extricate the best blends of elements. In the proposed calculation, each arrangement of components per leaf, adjusts a vector characterized by the quantity of descriptors or elements. The quantity of elements of every informational index characterizes the measure of every parallel string expected to actualize the hereditary calculation. The connection between every double string with the list of capabilities, is that 1 is taken as a utilized component and 0 as the nonattendance of that

element. The bent of every individual is taken from the exactness acquired by grouping the set comparing to that chain.

In the proposed system, the person with better fitness is taken and it passes in place to the people to come, it was utilized two-point crosses and transformation. Figure 4.2 demonstrates a case of chromosomal chains utilized and the classifier execution when highlights marked one are utilized. The dimensionality of the informational collection is an imperative classifiers execution factor. Some of the time improper characteristics can influence the execution of the classifier. Elements choice enhances the execution of a classifier. This issue has been tended to by a few creators, this issue is regular in design acknowledgment and it is usually called course of dimensionality. A critical factor when diminishing qualities, is to dispense with those that are not imperative to the classifier or discover the mix of characteristics that upgrades the execution of the classifier.

This approach consists of two leaf identification approaches that are Shape based approach and texture based approach both approach comprises of three stages, i.e. the pre-preparing, extraction of qualities and characterization, classification. Pre-preparing pictures is the trademark extraction stage required in this Recognition approach.

4.3.1 Units

The picture of the sheet is acquired through scanners or computerized Cameras All pictures of the leaves are in resolutions of 800 x 600. A RGB the picture is initially changed over to a grayscale picture. Eq1 is used to change over the RGB estimation of a pixel to its grayscale esteem.

$$\text{Grayscale} = 0.2989 R + 0.587G + 0.114B \quad (1)$$

Where R, G, B match to the colour of the pixel

4.3.2 Improvement of limits

The edge of a sheet is exceptionally attentive around this pre-processing. A picture pre-processing instance is demonstrated In Figure 4.2.



Figure 4.1 Binary images

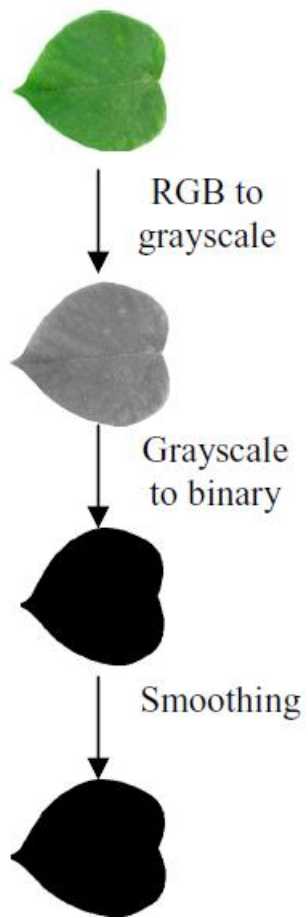

Figure 4.2 Chromosomal chains

4.3.3 Image Enhancement

After division of the leaf utilizing existing techniques, some additional work was expected to tidy up a few false positives ranges.

Removing undesired objects

Despite uniform establishment pictures were properly used, starting division become adequate when a photo contained the undesired items. Little fragments were commonly clean, little bugs or bits of leaves, notwithstanding different things. At the point when each and every little part was eradicated, if remaining part was only a solitary then we took that to be the leaf. The considering behind this is to discard parts that were not centered around the photo, which tend to be non-leaf objects. Finally, the fragment with the best locale from the rest of the parts was taken as the leaf.

Removing Stems

In the event that the stem was left in place, it would add commotion to the model of shape, given all the conceivable sizes it might take. First, every associated part was computed from the divided picture, and furthermore their quantity (heuristically, a stem does not influence what number of unique associated segments there are). When all stem competitors were figured, the one with the greatest zone and biggest viewpoint proportion was been the stem.



Figure 4.3 Stem remove

Resize Image

The model and flow was influenced adversely since the measure of shape pixels differed essentially. Our execution of the resize was connected to the entire cut picture, however the computations of tallness and width of the picture relied upon the leaf range. This implies coming about pictures may had diverse sizes, however the inner leaf ranges were the same or practically the same.

4.4 Feature Extraction

4.4.1 Shape Based Approach

Diameter: Diameter supposed to be the longest dividing or separating distance across two points or between two most concern points in the edge.

Leaf Area: The estimation of the area of leaf is anything but difficult to appraise, just checking the quantity of pixels of the binary value 1 in smoothing picture of the leaf. The area of leaf is known as A.

Leaf Perimeter: Perimeter of leaf is spoken to as P, Perimeter of leaf is figured by tallying the number of pixels that incorporates the margin of leaf.

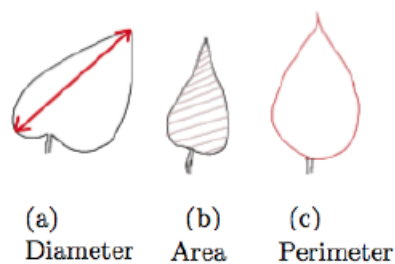

Figure 4.4 features

Major axis: The line section associating the base and the tip of the sharp edge is the fundamental pivot.

Minor axis: The max width, that is vertical to major axis, is the smallest shaft of leaf.

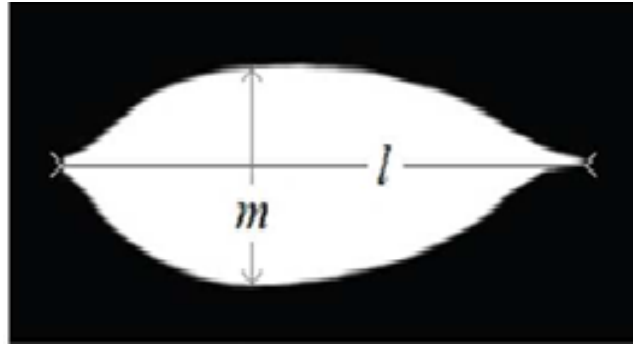

Figure 4.5 Represent Major axis l and
Minor axis m of a leaf

Convex Hull: Calculation of convex hull requires two spatial parameters. To start with the territory that of leaf and the second part of the convex hull on the leaf. The territory of the leaf is thought to be as the amount of pixels in given closer view and the part of the convex hull is computed as the quantity of pixels in the frame.



Convex Hull

Figure 4.6 Convex Hull

Eccentricity: Eccentricity of the ellipse with major axis m and minor axis l is defined as.

$$\text{Eccentricity} = \sqrt{\frac{l^2 + m^2}{l^2}}$$

Aspect Ratio: It is the ratio of the major axis m to minor axis l , therefore m / l .

Elongation: The elongation is obtained as the relation $2d_{\max} / D$ is the Ratio of the border of image and the diameter of the image. And border of the image is centre.

Solidity: The ratio $S = A / H$, that can be understood as a measure of convexity. Measure how well It is a curved shape.

Stochastic Convexity: The following variable explain the usual notion regarding the convexity in topological excessing the sampling for calculation to be performed. The object is regrading estimation of random segment's probability which is totally present in Image.

Isoperimetric Factor: Extraction of the isoperimetric remainder required extraction of the area and the perimeter of leaves. Given a binary leaf picture, the area is computed as the number of pixels in the closer view.

$$\text{Isoperimetric Factor} = \frac{4\pi A}{p^2}$$

Maximum indentation Depth: The C and L denote the centroid and arc length of image. The indent functions. It can be defined as Maximum indentation depth = C / L . It is displayed in one-degree intervals.

4.4.2 Texture Based Approach

Local Binary Pattern: There exist a few strategies for removing the most helpful elements from (pre-processed) leaf pictures to perform leaf acknowledgment. One of these element extraction techniques is the Local Binary Pattern (LBP) [19] [30] technique. This relative new approach was presented in 1996 by Ojala et al [30,19]. With LBP, it is conceivable to portray the surface and state of a computerized picture. This is done by partitioning a picture into a few little locales from which the elements are separated

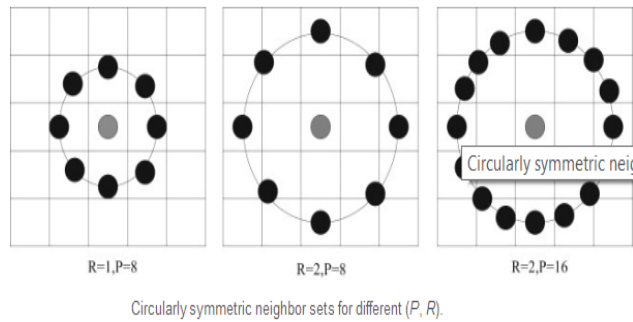

Figure 4.7 Shows the Radius and number of points

In the LBP approach, a "nearby pattern" portrays the connections between a pixel and its neighbours. The classic LBP administrator is characterized by looking at the gray value of focal pixels with its 8 nearby neighbourhood pixels. All neighbours that have esteem higher or equivalent to the estimation of focal pixels are given an estimation of 1, while each one of those lower values given an estimation of 0. The double values related with the neighbours are then gained consecutively, clockwise, to frame a parallel number which might be utilized to portray the nearby surface.

Histograms

Much the same as the LBPV created histograms that can be utilized for closeness seek. A few histograms were created at various span sizes and diverse perimeter pixel testing, so as to approve which blends gave the best outcomes. The Matlab execution restored a histogram of the element counts, where position i compares the include of pixels the leaf surface that had code i . Likewise, given that the usage is a LBPV, non-uniform codes are not utilized, in this manner, the container number i is the i^{th} include, not only the parallel code i . Figure 4.8 depicts in abnormal state how the way toward removing the nearby examples histograms works. To begin with, the picture is changed over to a dark scale picture. At that point, for every pixel inside the portioned leaf region, we ascertained the neighbourhood design with various sweep and circuit utilizing the usage. Finally, every illustration was consigned to a bowl inside the resulting histogram. The utilization of LBPV associated with the internal pixels of the leaf is capable. It takes around 1 up to 3 seconds to figure, depending of the variety of LBPV figured, and moreover the measure of the locale of the lead inside the photo.

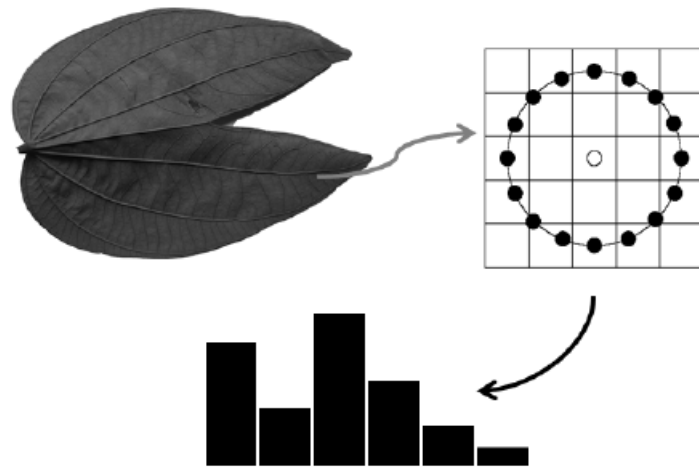

Figure 4.8 histograms works

4.5 Classification Based on Proposed Methods

When all elements were prepared and standardized, a machine learning calculation needed to be utilized to arrange inconspicuous pictures into species. We executed a similar grouping plot utilized by others.

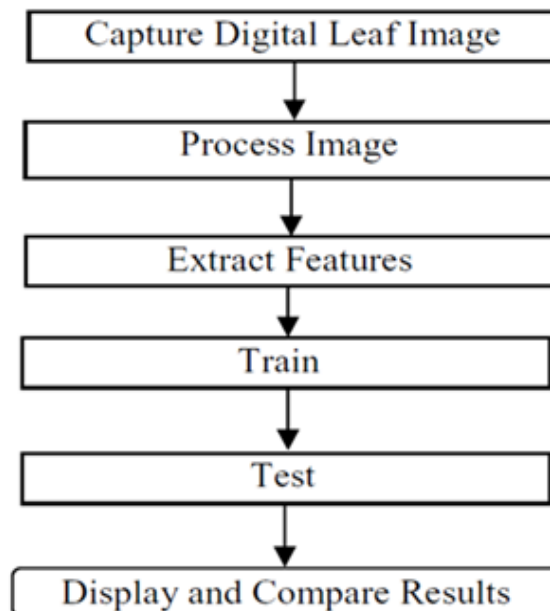

Figure 4.9 Process

Probabilistic Neural Network

The PNN [1] [3] – [6] is gotten from the RBFNN which is a simulated neuronal structure Using RBF. PNN has preparing speed commonly speedier than a BP spread system. Probabilistic Neural systems can be utilized for arrangement issues. Exactly when a data is accessible, the spiral base layer learns distances of the information vector to the planning input vectors and produces a vector whose parts exhibit the entrance is to an arrangement entrance. The competitive layer adds these duties regarding each class of commitments to make as its framework output a vector of probabilities. Finally, at the yield of the second layer the most extraordinary of these probabilities is picked, and produces a 1 for that class and a 0 for exchange classes.

PNN is grasped for it has many purposes of intrigue [1,3]. Its readiness speed is usually speedier than a BP organize. PNN can approach a Bayes perfect result under certain successfully met conditions [3-6]. Also, it is generous to disturbance cases. We pick it similarly for its direct structure and planning way. The most basic favored angle of PNN is that planning is basic and prompt [3-6]. Weights are not "readied" but instead doled out. Existing weights will never be substituted however so to speak new vectors are implanted into weight matrices while get ready. Thus, it can be used as a piece of progressing. Since the arrangement and running strategy can be completed by system control, the speed of PNN is fast. The framework characterizes input vector into a specific class since that class has the most extraordinary probability to be correct.

In this paper, the PNN has three layers: The Input layer, Radial Basis Layer and the Competitive Layer. Radial Basis Layer surveys vector expels between input vector and line weight vectors in weight structure. These partitions are scaled by Radial Basis Function nonlinearly. By then, the Competitive Layer finds the most concise partition among them, and along these lines finds the arrangement configuration closest to the information configuration in light of their different.

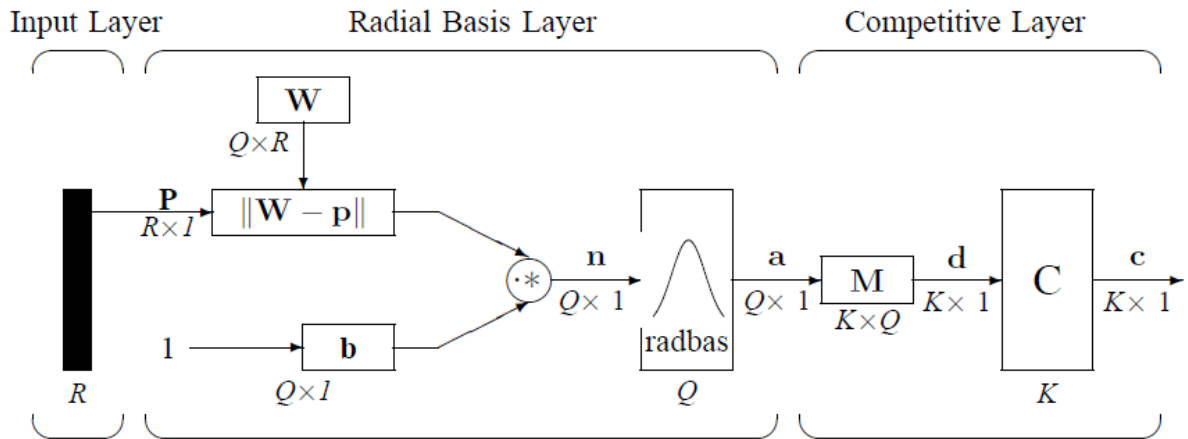

Figure 4.10 Network Structure of PNN

The system structure in our purposed plot is represented in Fig. 4.10. We embrace images and documentations utilized as a part of the book Neural Network Design. These images and documentations are additionally utilized by MATLAB Neural Network Toolbox. Measurements of clusters are set apart under their names.

The network classifies input vector Q into a specific class K because that class has the maximum probability to be correct. This PNN model has three layers: the Input layer, Radial Basis Layer and the Competitive Layer. At Radial Basis layer Q input is transposed to P' then evaluates vector distances between input vector and row weight vectors in weight matrix. These distances are scaled by Radial Basis Function nonlinearly. An input vector close to a training vector is represented by a number close to 1 in the output vector a . If an input is close to several training vectors of a single class, it is represented by several elements of a that are close to 1. Then the Competitive Layer weights are set to the matrix T of target vectors. Each vector has a 1 only in the row associated with that particular class of input, and 0s elsewhere. The multiplication Ta sums the elements of a due to each of the K input classes. Finally, it produces a 1 corresponding to the largest element of d , and 0s elsewhere. Thus, the network classifies the input vector into a specific K class because that class has the maximum probability of being correct.

Support Vector Machine

SVM [2] is a kind of classifier that it is a social event of related administered learning designs utilized uniquely to sort purposes. SVM will make a separating hyperplane in space, one that constructs the outskirts between the two game plans of data. Remembering the true objective to define up the limit, two comparative hyperplanes are conveyed, one in each of the hyperplane of parcel among the two arrangement of data.

For SVM, a data point is implied as a p -dimensional vector, and it is vital to isolate in case you can hole such focuses with a $p-1$ -dimensional hyperplane. This is alluded to as straight sorter as help vector machines are direct classifiers that can locate the perfect hyperplane that extends the Separation between designs, this trademark makes SVM as a possible hugeness for gathering purposes. At to start with, the entire educational file is confined into preparing (T1) and Test (T2) data heedlessly. The qualities of T1 are prepared using SVM classifier and attributes in T2 is Tested. Coordinate course of action shows that the decision surfaces are immediate components of the data vector and along these lines, are portrayed using dimensional hyperplanes inside the dimensional information space. A raised work is portrayed as an endless limit whose motivating force at the midpoint of each break in its region does not go past the calculating mean of its regards at the terminations of the between time. Since its neighborhood perfect course of action is overall perfect plan, the game plan is remarkable. A comprehensive perfect plan is the one in which there are no other possible game plans with better target work regards.

k Nearest Neighbor

The closest k -neighbor's calculation (k -NN) [2] is a non-parametric strategy used for grouping and relapse. In the two cases, the support involves the k preparing cases closest to the part space. The yield depends endless supply of whether k -NN is used for grouping or relapse. In the k -NN arrangement, yield is a class enlistment. An inquiry is masterminded by a bigger part vote of its neighbors, with the protest allotted to the most understood class among its k nearest neighbors (k is a positive whole number, regularly little). If $k = 1$, at that point the protest is fundamentally consigned to the class of that closest neighbor. In the relapse k -NN, the yield is the estimation of the property for the protest. This regard is the ordinary of the estimations of its k closest neighbors.

Chapter 5 Experimental Results

This section covers the outcomes gotten amid this exploration. A few trials were executed, measuring precision of our usage of the model of ebb and flow what's more, the model for texture. And report the exactness comes about acquired from primarily several tests. The data set cast-off in this method is leaf dataset. For each plant type in the leaf data set, 5-6 pieces of the sheets of the test groups are used to check the algorithm.

5.1 Shape Based Approach

5.1.1 Accuracy Results

Table 5.1 demonstrates the exactness of the ordered algorithms in dataset. The correctness of the planned PNN Ranking methodology is contrasted through the closest k-NN and SVM classification approach. It is seen from the i.e. PNN classification method exceeds the k-NN and SVM. The precision acquired by PNN in leaf information is 88.6% while the exactness of k-NN is 86% and by SVM is 80%.

Approach	PNN	k-NN	SVM
Accuracy	88.6%	86%	80%

Table 5.1 Comparison of the Classification of the Accuracy

5.1.2 Execution time

Table 5.2 shows execution time of each algorithm, k-NN 0.34 seconds for the execution, while the PNN takes only 0.18 seconds and SVM takes 1.34 seconds.

Approach	PNN	k-NN	SVM
Execution Time	0.18 s	0.34 s	0.4s

Table 5.2 Comparison of the Execution Time

5.2.1 Texture Based Approach

5.2.1 Accuracy of LBP

Table 5.3 demonstrates the exactness of the ordered algorithms in dataset. The accuracy of the proposed SVM Ranking methodology is contrasted with the closest k-NN and PNN classification methods. In table R means Radius and N means number of nearest neighbours.

Approach (Accuracy)	SVM	k-NN	PNN
R = 1 N = 8	84%	68%	63%
R = 2 N = 8	70%	67%	52%
R = 2 N = 16	84%	68%	44%

Table 5.3 Comparison of the classification accuracy

5.2.2 Execution time of LBP

It can be observed from Table 5.4 that in the leaf database, k-NN classifier takes less execution time, while the SVM takes mild time and PNN takes more execution time.

Approach (Execution Time)	SVM	k-NN	PNN
R = 1 N = 8	1.1 s	0.509 s	2.30 s
R = 2 N = 8	0.52 s	0.109 s	2.05 s
R = 2 N = 16	0.56 s	0.11 s	1.09 s

Table 5.4 Comparison of the Execution Time

6.1 Conclusion

The discoveries of this examination are the sorts of leaf highlights that ought to be removed, outside elements that must be considered before the extraction procedure, sorts of extraction and order techniques that can be utilized for plant acknowledgment and order. In other words, the aftereffects of this examination can be utilized as a particular of leaf highlights that must be considered for plant acknowledgment and arrangement purposes. Three classifiers have been chosen for testing and future advancement. The choice will be in light of sort of leaf highlights that can be extricated and perceived and capacity of the pre-handling strategy to handle the commotion or other outside variables in the picture. A proficient machine Learning approach for the recognition of the leaves of the examination. The approach comprised of three stages: Pre-processing stage, extraction period of Classification stage and execution. There are two approaches for classification recognition of leaf i.e. shape based and texture based approach. In shape based PNN classifier [1] is received for the classification method as it gives the better precision, faster preparing rate and straightforward structure whereas in texture based SVM classifier perform better as in faster rate and simple structure and also in accuracy. 13 features and LBP i.e. LBP [19][30] with different radius and neighbor are extracted and handled to frame the different classification algorithms input vector.

The interpretation of the advised approach is overviewed on the start of precision and final execution time. PNN, k-NN and SVM method, the advised calculation delivers more amazing precision and it requires significantly less time for execution. For encourage examination, by joining gainful piece works, the execution of the sorter can be pushed ahead. Leaf division become a key part of leaf acknowledgment calculation. The division approach executed in this examination, ought to be enhanced to be more exact, since it has coordinate ramifications on both model and flow and surface model exhibited in this examination. Model and flow is by all accounts considerably more influenced by false divisions, making a surface based model stronger to clamor caused by incorrect division. The coming about pictures were appropriate for leaf acknowledgment executed by people, be that as it may not for the displayed

calculations. This caused the picture catching from those physical examples to wind up plainly pointless for this examination.

6.2 Future Scope

These days the experts accountable for Herbaria catch pictures of physical examples that are not reasonable for momentum computer inspiration explore. We trust they should begin producing snapshot of the whole example, as well as of takes off, organic products, surfaces, and whatever other valuable piece of the plant for programmed acknowledgment in isolate pictures. This could affect emphatically the Biodiversity Informatics people group. The pictures ought to likewise be caught previously, then after the fact the squeezing/drying prepare.

References

- [1] Wu, Stephen Gang, et al. "A leaf recognition algorithm for plant classification using probabilistic neural network." *Signal Processing and Information Technology, 2007 IEEE International Symposium on*. IEEE, 2007.
- [2] Priya, C. Arun, T. Balasaravanan, and Antony Selvadoss Thanamani. "An efficient leaf recognition algorithm for plant classification using support vector machine." *Pattern Recognition, Informatics and Medical Engineering (PRIME), 2012 International Conference on*. IEEE, 2012.
- [3] Amlekar, Manisha, et al. "Leaf features based plant classification using artificial neural network." *IBMRD's Journal of Management & Research* 3.1 (2014): 224-232.
- [4] Şekeroğlu, Boran, and Yücel İnan. "Leaves Recognition System Using a Neural Network." *Procedia Computer Science* 102 (2016): 578-582.
- [5] Kadir, Abdul, et al. "Leaf classification using shape, color, and texture features." *arXiv preprint arXiv:1401.4447* (2013).
- [6] Munisami, Trishen, et al. "Plant leaf recognition using shape features and colour histogram with K-nearest neighbour classifiers." *Procedia Computer Science* 58 (2015): 740-747.
- [7] Mallah, Charles, James Cope, and James Orwell. "Plant leaf classification using probabilistic integration of shape, texture and margin features." *Signal Processing, Pattern Recognition and Applications* 5.1 (2013).
- [8] Patil, Bhagya, Anupama Pattanshetty, and Suvarna Nandyal. "Plant classification using SVM classifier." (2013): 519-523.
- [9] Arora, Akhil, et al. "A Plant Identification System using Shape and Morphological Features on Segmented Leaflets: Team IITK, CLEF 2012." *CLEF (Online Working Notes/Labs/Workshop)*. 2012.

- [10] Arun, C. H., WR Sam Emmanuel, and D. Christopher Durairaj. "Texture feature extraction for identification of medicinal plants and comparison of different classifiers." *International Journal of Computer Applications* 62.12 (2013).
- [11] Beghin, Thibaut, et al. "Shape and texture based plant leaf classification." *International Conference on Advanced Concepts for Intelligent Vision Systems*. Springer, Berlin, Heidelberg, 2010.
- [12] Bhardwaj, Anant, Manpreet Kaur, and Anupam Kumar. "Recognition of plants by leaf image using moment invariant and texture analysis." *International Journal of Innovation and Applied Studies* 3.1 (2013): 237-248.
- [13] Rashad, M. Z., B. S. El-Desouky, and Manal S. Khawasik. "Plants images classification based on textural features using combined classifier." *International Journal of Computer Science and Information Technology* 3.4 (2011): 93-100.
- [14] Pushpa, B. R., C. Anand, and P. Mithun Nambiar. "Ayurvedic Plant Species Recognition using Statistical Parameters on Leaf Images." *International Journal of Applied Engineering Research* 11.7 (2016): 5142-5147.
- [15] Wang, Zhiyong, Zheru Chi, and Dagan Feng. "Shape based leaf image retrieval." *IEEE Proceedings-Vision, Image and Signal Processing* 150.1 (2003): 34-43.
- [16] Hajjdiab, Hassan, and Iman Al Maskari. "Plant species recognition using leaf contours." *Imaging Systems and Techniques (IST), 2011 IEEE International Conference on*. IEEE, 2011.
- [17] Nanni, Loris, Alessandra Lumini, and Sheryl Brahmam. "Survey on LBP based texture descriptors for image classification." *Expert Systems with Applications* 39.3 (2012): 3634-3641.
- [18] Ferrer, Miguel A., Aythami Morales, and Umapada Pal. "Lbp based line-wise script identification." *Document Analysis and Recognition (ICDAR), 2013 12th International Conference on*. IEEE, 2013.

- [19] Ojala, Timo, Matti Pietikäinen, and Topi Mäenpää. "Gray scale and rotation invariant texture classification with local binary patterns." *European Conference on Computer Vision*. Springer, Berlin, Heidelberg, 2000.
- [20] Janani, R., and A. Gopal. "Identification of selected medicinal plant leaves using image features and ANN." *Advanced Electronic Systems (ICAES), 2013 International Conference on*. IEEE, 2013.
- [21] Sharma, Sapna, and Chitvan Gupta. "Recognition of plant species based on leaf images using multilayer feed forward neural network." *International Journal of Innovative Research in Advanced Engineering* 2.6 (2015): 104-110.
- [22] Sumathi, C. S., and AV Senthil Kumar. "Neural Network based Plant Identification using Leaf Characteristics Fusion." *International Journal of Computer Applications* 89.5 (2014).
- [23] Jalili, Laura D., et al. "Improving the Performance of Leaves Identification by Features Selection with Genetic Algorithms." *Workshop on Engineering Applications*. Springer, Cham, 2016.
- [24] Hajjdiab, Hassan, and Iman Al Maskari. "Plant species recognition using leaf contours." *Imaging Systems and Techniques (IST), 2011 IEEE International Conference on*. IEEE, 2011.
- [25] Boser, Bernhard E., Isabelle M. Guyon, and Vladimir N. Vapnik. "A training algorithm for optimal margin classifiers." *Proceedings of the fifth annual workshop on Computational learning theory*. ACM, 1992.
- [26] Chaki, Jyotismita, and Ranjan Parekh. "Designing an automated system for plant leaf recognition." *International Journal of Advances in Engineering & Technology* 2.1 (2012): 149.
- [27] Sethulekshmi, A. V., and K. Sreekumar. "Ayurvedic leaf recognition for Plant Classification." *Journal of Computer Science and Information Technologies* 5.6 (2014): 8061-8066.

- [28] Hammel, Mark S., Przemyslaw Prusinkiewicz, and Brian Wyvill. "Modelling compound leaves using implicit contours." *Visual Computing*. Springer, Tokyo, 1992. 199-212.

- [29] Li, Yan, Zheru Chi, and David D. Feng. "Leaf vein extraction using independent component analysis." *Systems, Man and Cybernetics, 2006. SMC'06. IEEE International Conference on*. Vol. 5. IEEE, 2006.

- [30] Werghi, Naoufel, Stefano Berretti, and Alberto Del Bimbo. "The mesh-lbp: a framework for extracting local binary patterns from discrete manifolds." *IEEE Transactions on Image Processing* 24.1 (2015): 220-235.

- [31] Ojala, Timo, Matti Pietikainen, and Topi Maenpaa. "Multiresolution gray-scale and rotation invariant texture classification with local binary patterns." *IEEE Transactions on pattern analysis and machine intelligence* 24.7 (2002): 971-987.

2017 4th International Conference on Signal Processing, Computing and Control (ISPC) - Track 1: Signal Processing # (1570374370): *Plant Classifier based on Leaf Shape and Texture features*