

DISSERTATION

On

**Dynamic Analysis and Control of Semi Active Suspension System for a
Heavy Vehicle: A Bond Graph Approach**

***Submitted in partial fulfillment of the requirement
for the award of degree of***

Master of Engineering

in

Production & Industrial Engineering

Submitted By :

JAGJIT SINGH

Roll No. 801182010

Under The Guidance of

Dr. Tarun Kumar Bera

Assistant Professor

Department of Mechanical Engineering

Thapar University, Patiala



DEPARTMENT OF MECHANICAL ENGINEERING

THAPAR UNIVERSITY

PATIALA-147004, INDIA

JULY-2013

This Thesis is dedicated to

My Respected Teacher

Dr. Tarun Kumar Bera

DECLARATION

I hereby declare that work done in this Thesis Report entitled, “**Dynamic Analysis and Control of Semi active Suspension System for a Heavy Vehicle: A Bond Graph Approach**” submitted towards partial fulfillment of requirement for award of **Master of Engineering** degree in **Production & Industrial Engineering** in **Mechanical Engineering Department** of **Thapar University, Patiala**, is an authentic record of work carried out by me under the supervision and guidance of **Dr. Tarun Kumar Bera, Assistant Professor** of **Mechanical Engineering Department, Thapar University, Patiala**.

This matter embodied in this report has not been submitted in part or full to any other university or institute for the award of any degree.



Jagjit Singh

This is to certify that above declaration made by the student concerned is correct to the best of my knowledge & belief.



Dr. Tarun Kumar Bera

Assistant Professor

Mechanical Engineering Department

Thapar University, Patiala

Countersigned by:



Dr. Ajay Batish

Head of ME Department

Thapar University, Patiala



Dr. S.K. Mohapatra

Dean of Academic Affairs

Thapar University, Patiala

ACKNOWLEDGEMENT

I take the opportunity to express my heartfelt adulation and gratitude to my supervisor Dr. Tarun Kumar Bera for his unreserved guidance, constructive suggestions, thought provoking discussions and unabashed inspiration in the nurturing work. It has been a benediction for me to spend many opportune moments under the guidance of the perfectionist at the acme of professionalism. The present work is testimony to his activity, inspiration and ardent personal interest, taken by him during the course of his work in its present form. I am grateful to Dr. Ajay Batish, Professor and Head, Mechanical Engineering Department for providing the facilities for the completion of the work and always being a shelter in the odd days.

I would like to express my sincere gratitude to all who directly or indirectly helped me for the successful completion of my thesis work.

Finally, I will always remember the best wishes from my brother Ravi kumar and blessings of my parents concerning this venture. Without their encouragement, patience and moral support it would not have been possible for me to complete my thesis.

Jagjit Singh
Jagjit Singh

Roll No.- 801182010

ABSTRACT

Automotive industry is working very fast to improve rider comfort and vehicle stability by using technology from electronics, electrical and material science engineering. A highly controlled suspension system will provide good isolation from noise and vibration. The semi active actuators are tremendous part of the vibration isolator in the vehicle suspension system. In the semi active suspension system, the damping coefficient can be varying to enhance the comfort for passengers and high vehicle handling. The detailed bond graph model of passive, skyhook and semi active suspension systems are developed. Bond graph model of bicycle vehicle model is developed and in this model, passive and semi active suspension systems are attached and a comparison of both the systems for evaluating the heave and pitch motion of vehicle is done. R-S control strategies are used in semi active suspension system to control the vehicle from varying road disturbance. Solenoid valve is modelled as a bond graph modelling technique and is used in bicycle vehicle model as semi active solenoid valve and the performance of vehicle is evaluated with the use of appropriate control strategy.

Keywords: Semi active suspension system, Bicycle vehicle model, Solenoid valve, R-S control, Bond graph.

LIST OF ABBREVIATIONS

BBM	Black Box Model
C	Capacitance
CATS	Computer Active Technology Suspension
De	Effort Detector
Df	Flow Detector
DOF	Degrees of Freedom
ECASS	Electronically Controlled Active Suspension Systems
GY	Gyrator
I	Inertance
LPV	Linear Parameter Varying
MSE	Modulated Sources of Effort
MSF	Modulated Sources of Flow
MTF	Modulated Transformer
MR	Magneto Rheological
MGY	Modulated Gyrator
NNOE	Neural Network Output Error
PI	Proportional Integral
PID	Proportional Integral Derivative
R-S	Rakheja-Sankar
RMS	Root Mean Square
R	Resistance
SE	Source of Effort
SF	Source of Flow
SMC	Sliding Mode Control
SDOF	Single Degree of Freedom
TF	Transformer
VSC	Variable Structure Control

VDC

Vehicle Dynamics Control

NOMENCLATURE

a	Distance between the car centre of gravity and front axle (m)
A_v	Area of Valve (m^2)
b	Distance between the Car Centre of Gravity and Rear axle (m)
B	Stiffness Factor
c	Damper (N.s/m)
C	Shape Factor
C_d	Discharge Coefficient
C_{FV}	Foot Valve Discharge Coefficient
d	Difference between the Front and Rear axle (m)
d_1	Initial Distance of Car from Bump (m)
D	Peak Value
E	Energy (J)
F	Force (N)
F_s	Semi Active Force (N)
F_d, F_k	Damping and Spring Force (N)
G	Gear ratio
h	Height of Bump (m)
J_C	Polar Moment of Inertia of Car ($kg \cdot m^2$)
k, k_w	Stiffness of Spring (N/m)
k_f, k_r	Stiffness of Front and Rear Spring (N/m)
k_v	Stiffness of Valve Spring (N/m)
l	Length of Bump (m)
L_s	Length of Solenoid (m)
m	Mass (kg)
m_w	Mass of Wheel (kg)

m_p	Mass of Piston (kg)
M_b	Sprung Mass of Quarter Car Body (kg)
M_w	Un-sprung Mass of Wheel (kg)
P_c, P_E	Compression and Extension Chamber Pressure (N/m^2)
P_{0gas}	Initial Gas Chamber Pressure (N/m^2)
Q_{FV}	Flow Rate of Foot Valve (m^3/s)
R_r	Radius of the Piston Rod (m)
R_{eqv}	Equivalent Radius (m)
R_{motor}	Resistance of Motor (Ω)
R	Resistance (Ω)
U	Road Displacement (m)
v	Velocity (m/s)
v_{ref}	Reference Velocity (m/s)
V_{0gas}	Initial Gas Volume (v^3)
V_1, V_2	Velocity of Sprung and Un-sprung (m/s)
X	Displacement of Mass Movement (m)
X_1, X_2	Movement of Mass (m)
X_2	Road Displacement (m)
\ddot{X}_1	Acceleration of Mass (m/s^2)
\dot{x}, \dot{y}	Velocity (m/s)
\dot{x}, \dot{z}	Velocity of two Directions (m/s)
τ	Torque
ω	Frequency (rad/sec)
$\dot{\theta}$	Angular Velocity (rad/sec)
μ_{motor}	Motor Torque Constant (N.m/A)
β	Bulk Modulus of Fluid (N/m^2)
ρ	Density of Fluid (kg/m^3)

SUBSCRIPTS

b	Body
c	Car
C	Compression
d	Discharge
eqv	Equivalent
E	Extension
f	Front
FV	Foot Valve
k	Spring
p	Piston
r	Rear
ref	Reference
s	Solenoid
v	Valve
w	Wheel
0gas	Initial Value of gas

LIST OF FIGURES

<u>FIGURE NO.</u>	<u>TITLE</u>	<u>PAGE NO.</u>
1.1	Passive Suspension System	5
1.2	Active Suspension System	6
1.3	Semi Active Suspension System	8
1.4	Solenoid Valve Semi Active Suspension System	9
1.5	Quarter Car Model of Semi Active Suspension System	11
3.1	Word Bond Graph of Engine to Wheel	32
3.2	Word Bond Graph of Wheel Sensor	32
3.3	(a) Exchange of Power and (b) Causality in Bond Graph Representation	33
3.4	Word Bond Graph Motor to Wheel	33
3.5	Causality of Inertia and Compliant Element	34
3.6	Causality of R element	34
3.7	Causality of Transformer	34
3.8	Causality of Gyrator	35
3.9	Causality of Junction Element	35
3.10	Differential Causality of C and I Element	37
3.11	Spring Mass System and its Causalled Bond Graph	37
3.12	Passive Suspension System	38
3.13	Bond Graph Model of Passive Suspension System	38
3.14	Transmissibility of Passive Suspension System	39
3.15	Ideal Skyhook Suspension System	40
3.16	Bond Graph Model of Skyhook Suspension System	41
3.17	Transmissibility of Skyhook Suspension System	42
3.18	Semi Active Suspension System	43
3.19	Bond Graph Model of Semi Active Suspension System	43

3.20	Transmissibility of Semi Active Suspension	44
4.1	Schema of Planar Vehicle	46
4.2	Bond Graph Model of Planar Vehicle Body with No Drive	47
4.3	Bond Graph Model of Planar Vehicle with Passive System	48
4.4	Heave and Pitch Motion of Vehicle with Passive System	50
4.5	Passive Suspension Outputs	50
4.6	1-DOF Quarter Car Model	51
4.7	Bond Graph Model with Semi Active Suspension System	52
4.8	Heave Motion of Vehicle with Bump Excitation	54
4.9	Pitch Motion of Vehicle with Semi Active System	55
4.10	Vehicle's Velocity with Semi Active System	55
4.11	Semi Active Suspension System Outputs	56
4.12	Semi Active Solenoid Valve	57
4.13	Bond Graph of Semi Active Solenoid Valve	58
4.14	Bond Graph of Planar Vehicle Model with Solenoid Valve	60
4.15	Heave Motion of Planar vehicle with solenoid Valve Model	61
4.16	Pitch Motion of Vehicle Body with Semi Active Solenoid Valve	61

LIST OF TABLES

<u>TABLE NO.</u>	<u>TITLE</u>	<u>PAGE NO.</u>
3.1	Power Variables in Different Energy Domains	30
3.2	Definition of Bond Graph Elements	31
3.3	Definition of Signal Bonds and Sensors	36
3.4	Parameter Values of Passive Suspension System	39
3.5	Parameter Values of Skyhook Suspension System	42
3.6	Parameter Values of Semi Active Suspension System	44
4.1	Parameter Values for Planar Vehicle Model with Passive System	49
4.2	Parameter Values for Outputs of Passive Suspension System	50
4.3	Parameter Values Used in Simulation of Planar Vehicle Model	53
4.4	Parameter Values for Outputs of Semi Active Suspension System	56
4.5	Parameter Value of Vehicle Model with Solenoid Valve	60

TABLE OF CONTENTS

DECLARATION	ii
ACKNOWLEDGEMENT	iii
ABSTRACT	iv
LIST OF ABBREVIATION	v
NOMENCLATURE	vii
LIST OF FIGURES	x
LIST OF TABLES	xii
CHAPTER 1: INTRODUCTION	1
1.1. Background and Motivation	1
1.2. Suspension System	2
1.2.1 Objective of Suspension System	3
1.3. Classification of Suspension System	4
1.3.1. Passive Suspension System	4
1.3.2. Active Suspension System	5
1.4. Types of Active Suspension System	7
1.4.2. Hydraulic Actuated Suspension	7
1.4.2. Electromagnetic Recuperative Suspension	7
1.5. Semi Active Suspension System	8
1.5.1 Types of Semi Active Suspension System	9
1.5.1.1 Solenoid or Valve Actuated	9
1.5.1.2 Magneto-Rheological	10
1.6. Basic Model of Quarter Car Model	10
1.7. Semi Active Control Algorithms	11
1.7.1. PID controller	12

1.7.2. Adaptive Control	12
1.7.3. Robust Control	13
1.8. Contribution of Thesis	14
1.9. Organization of the Thesis	14
CHAPTER 2: LITERATURE REVIEW	16
2.1. Introduction	16
2.2. Bond graph Modeling	16
2.3. Bond Graph Modeling of Vehicles	17
2.4. Semi Active Suspension System	18
2.5. Literature Gap	26
2.6. Objective of the Present Work	26
CHAPTER 3: PRINCIPLE OF WORK	28
3.1. Introduction	28
3.2. Bond Graph	28
3.2.1 Junction	32
3.2.2. Causality	32
3.2.3 Activation	35
3.2.4. Sensors and Actuators	35
3.2.5. Differential Causality	36
3.2.6. Example on Assignment of Causality	37
3.3. Passive Suspension System	37
3.4. Skyhook Suspension System	40
3.5. Semi Active Suspension System	42
CHAPTER 4: DEVELOPMENT AND CONTROL OF SEMI ACTIVE SUSPENSION SYSTEM	45
4.1. Introduction	45
4.2. Planar Vehicle Model	45
4.2.1. Kinematic Relation	46
4.2.2. Bond Graph Model	46
4.3. Vehicle Model with Passive Suspension System	47

4.3.1. Simulation Result for Passive System	49
4.4. R-S Control Method	51
4.5. Vehicle with Semi Active Suspension System	52
4.6. Performance Analysis	53
4.7. Solenoid Valve Semi Active Damper	56
4.7.1. Modeling of Solenoid Valve	56
4.7.2. Bond Graph Model of Solenoid Valve	57
4.7.3. Simulation Results	59
CHAPTER 5: CONCLUSIONS	62
5.1. Conclusion	62
5.2. Scope of Future Work	62
REFERENCES	63
CURRICULUM VITAE	69

The research on vehicle dynamics is a current trend now-a-days. The modern vehicle consists of different components such as vehicle chassis, wheel, two wheel or four wheel steering system, active, semi active or pneumatic suspension, different control systems *etc.* The suspension system is a mechanical system that consists of the springs and shock absorbers to connect the wheels and axles to the chassis of the vehicle. The function of suspension system is to maximize the friction (damping force) and to carry the static weight of the vehicle between the tyres and the road surface and smooth out of a bumpy road for the comfort of the passengers and steering stability with good handling performance.

1.1 BACKGROUND AND MOTIVATION

The suspension system consists of spring and shock absorber. Three types of suspension system are used in vehicles: active suspension, passive suspension and semi active suspension system. Passive suspension system consists of spring and damper. Spring is used for energy storing element and damper dissipate the energy to the system. It has fix characteristics. Active suspension system consists of spring and here damper is replaced with force actuator. In active system, force actuators are used to add or dissipate the energy from system. Appropriate control strategies are used to control the system. This system gives the better performance than the passive system. In semi active suspension system, passive damper are replaced with variable damping coefficient. The damping coefficient is determined based on the control strategy used in the system. Damping coefficient should be automatically changed or adjusted at desired level. By using the semi active suspension system in a bicycle vehicle model, the performance is evaluated due to improvement of ride comfort, vehicle stability for road disturbance. Semi active systems are more well performer than the passive and active suspension system. Therefore, the semi active suspension systems are used in bicycle vehicle model to improve the vehicle stability. The performance of passive, skyhook, and semi active systems are evaluated by obtaining the transmissibility and output of the system. Semi

active suspension systems are used in the bicycle vehicle model and after that another type of semi active suspension system *i.e.*, semi active solenoid valve is used in the system for making the model more comfortable. The performance of semi active and passive systems is compared with heave and pitch motion of vehicle by using the appropriate control strategy. Semi active solenoid valve is designed and implemented on the bicycle vehicle model. The motivation of advanced suspension system is that, it can be used to produce the good ride handling and comfort for the passengers. In semi active suspension system, Rakheja-Sankar (R-S) control strategy is used in the system to provide good isolation from vibration.

1.2 SUSPENSION SYSTEM

The suspension system consists of springs, shock absorber, arm rods and axle and ball joints. Out of these spring is a flexible component of the suspension. The main purpose of suspension system is to free from the vibration and bump road during the motion of vehicle. There are many types of springs to isolate the vibration; these springs are leaf spring, coil springs and torsion bars. Modern vehicles use the light coil springs. Light commercial vehicles have heavier springs than the passenger vehicles at which coil spring are at the front and leaf springs are attached at the rear suspension system. But the heavy commercial vehicles usually use the leaf springs or air suspension and in heavy vehicles solid beam and axles are connecting the wheels on each side.

The suspension system provides the effective isolation of passengers and load disturbance. Soft suspension provides the good ride comfort for passenger and requires stiff suspension for insensitivity to the loads. The suspension system is designed in such a way that a good compromise between the ride comfort, vehicle handling and load carrying capacity could be done. The automation suspension has two goals: comfort for passenger and vehicle handling. Comfort is provided by isolating the vehicle from the bumps. Handling of vehicle is achieved from rolling and pitching and good contact between the road and wheel.

Today, the suspension uses the hydraulic damper and spring for absorbing the motion from the bump and minimizes the motion of vehicle. Generally suspension has two components *i.e.*, spring and damper. Spring is flexible components and is chosen

based on the weight of vehicle while damper defines the suspension placement on compromise curve. Damper provides the isolation at low frequency road disturbance and absorb at high frequency road disturbance. Out of these, low frequency disturbances are best when damping is high. Three types of suspension are reviewed *i.e.*, passive, active and semi active suspension. Spring and damper are basic components of passive suspension system. Spring stores the energy and damper dissipates the energy and both are fixed in nature. If the damper is replaced with force actuator, suspension becomes active. In the semi active suspension, damper is replaced with semi active damper and changes the damping coefficient with time. Control algorithms are used to control the vehicle.

There are many properties of suspension system which is achievable for handling or road holding, comfort and vibration isolation. These properties are spring rate or suspension rate, roll couple percentage, weight transfer, wheel rate, jacking forces, damping, camber control, roll center height.

1.2.1 OBJECTIVE OF SUSPENSION SYSTEM

- i) System provides the good ride and handling performance and it evaluates the following aspects:
 - The wheels follow the road profile
 - Little tyre load fluctuation
 - Vertical compliance provide the chassis isolation
- ii) Ensure that the steering control is maintained
 - Maintain the wheels in the proper position with respect to road surface
- iii) To ensure that the vehicle responds favourably to control the forces produced by the tyres during the following aspects:
 - Longitudinal braking
 - Accelerating forces
 - Lateral cornering forces
 - Braking and accelerating torques
 - The suspension geometry to be designed in such a way that to resist squat, dive and roll of the vehicle body

iv) Providing the isolation at high frequency vibration from tyre excitation and following aspect are followed:

- Appropriate isolation is required in the suspension joints
- Prevent transmission of 'road noise' to the vehicle body

1.3 CLASSIFICATION OF SUSPENSION SYSTEM

There are three types suspension system

- Passive Suspension system
- Active Suspension System
- Semi-Active suspension system

1.3.1 Passive Suspension System

This is a conventional suspension system in which two basic elements are used. These two elements are spring and damper. The function of spring in a suspension system is to control the static weight of the vehicle and it can be used for an energy storing elements. The function of damper is to dissipate the vibration energy. It has significantly limitation for completely controlling the vehicles. The passive suspension is a fix characteristic, if the designer design the heavy suspension damped, it will be good vehicle handling but on the contrary, road disturbance will be more to the vehicle. If the suspension is lightly damped, it will be more comfortable but this suspension will reduce the vehicle stability while turning. Different type of spring and damper can be used by the designer, but the passive type suspension is considered as spring and damper are parallel to each other. This spring damper unit called strut is shown in Fig. 1.1. This type of suspension can not add energy to the system and so this suspension is called the passive. To improve the performance of this kind of suspension system, another element means, roll spring are attached to increase the stiffness of roll motion. This suspension system can be used to control the dynamics of vertical motion of the body. This system leads to compromise between the ride and handling. Figure 1.1 shows the passive suspension system which consists of spring and damper.

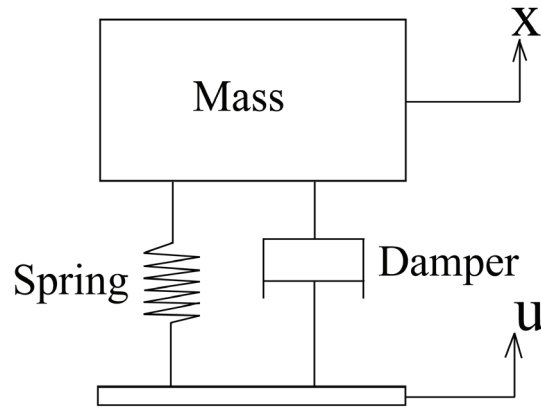

Fig. 1.1 Passive Suspension System

1.3.2 Active Suspension System

Active suspension system has ability to vertical changes in the road disturbance. In active suspension, damper is replaced with a force actuator. Basic components of system are shown in Fig. 1.2. The function of force actuators add energy or dissipate energy from the system. The force actuator can be controlled with various types of controllers by designer. The force actuator can apply the force independent to the relative displacement and velocity. Therefore, the correct control policy will give better improvement of ride comfort and stability of vehicle as compared to passive suspension system. Due to use of an active suspension system, reduction of vertical acceleration of sprung mass is large.

Design of the road and load disturbance responses are independently considered in the active suspension system. Therefore, this technology will give better ride quality and vehicle handling to the passenger by keeping the tyres perpendicular to the road. Figure 2.2 describes the basic components of active suspension system. In this system, the controllers modify the system for improving the vehicle stability by activating the actuator. For improving the performance of vehicle, the road input (disturbance) may be modelled as white noise velocity input. In this study active suspension system can reduce the root mean square (RMS) acceleration of sprung mass. Active suspension has control over the attitude of the vehicle. The effect of braking can be reduced and as a result, vehicle to nose dive. By using this suspension, it reduces the rolling of vehicle during cornering-maneuvers.

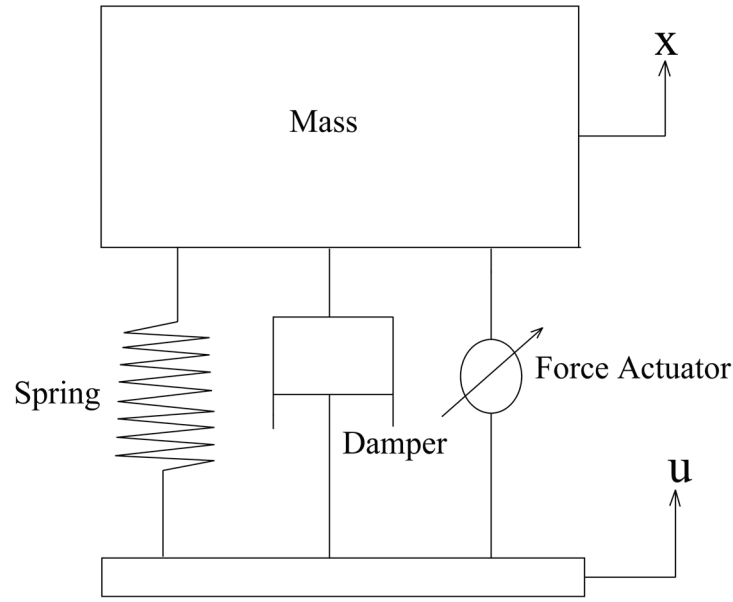

Fig. 1.2 Active Suspension System

Active suspension system has its own advantage and disadvantage. The performance is better than the passive suspension system because of passive system has a fix design of suspension and it has an open loop control system. This type of system does not give any feedback signal for correcting the error. Therefore, this suspension will not give the improving ride comfort and vehicle stability. But in active suspension, it will give better ride comfort because the force actuator is controlled by the controller. Active suspension system is a close loop control system. According to this controller, it will correct the error or give the output at the desired goal.

Right control strategy in this suspension system is to ride quality and handling performance should be optimized. Overall, the active suspension system has a capability to changing the road condition to extend the design parameters of system by monitoring and adjusting the input. But in active suspension system, force actuator will need a large power requirement. Due to this large power requirement, the overall performance of the vehicle will be decreased. Another drawback in active suspension system is that they have an acceptable failure mode. Therefore, due to the failure of the actuator the vehicle would be left un-damped. The active suspension system has high cost and very complicated structure. They need the maintenance due to some implementation. This

system maintenance is problematic and only a factory authorized dealer will have the tools and mechanics to repair for the active suspension system.

1.4 TYPES OF ACTIVE SUSPENSION SYSTEM

1. Hydraulic actuated Suspension
2. Electromagnetic recuperative suspension

1.4.1 Hydraulic Actuated Suspension

Hydraulic actuated suspension systems are controlled by the hydraulic servomechanism. Servo supplies the hydraulic pressure by a high pressure radial piston hydraulic pump. The ride level, vehicle stability and any body movement of system should be continually monitored by the sensor which is connected to the computers. Computers receive all the processing data and then it operate the hydraulic servo, which is mounted on each wheel. These servo-suspensions generate the forces to lean, dive, and squat. The feature of this suspension system is that it has a height adjustable and desired self leveling suspension system. Computer Active Technology Suspension (CATS) is the best for balance between ride quality and vehicle handling by analyzing the road condition. The electronically control policies are achieved for this purpose.

1.4.2 Electromagnetic Recuperative Suspension

This type of suspension system is a linear electromagnetic motor that are attached to each wheel of the vehicle. It has very fast and quick response and power can be generated by utilization motor as generators. The hydraulic suspension system has a slow process response and large power consumption to operate the system. Therefore, this system is operated for fast response and less power consumption. This type of suspension is developed by L-3 Electronics system. Electronically controlled active suspension systems (ECASS) are patent by University of Texas center for electro-mechanism in the 1990. This type of suspension system is used for the military vehicles. The electronically controlled active suspension system exceeds the performance specification for the evaluation of all performance in terms of power to the ride quality, vehicle stability and vehicle operator.

1.5 SEMI ACTIVE SUSPENSION SYSTEM

Semi active suspension system was first introduced in 1970. This system does not provide any energy but the damper is replaced by a controllable damper. It provides the rapid change of damping coefficient. The damping coefficient should be determined based on the control strategy which is used in this suspension system. The damper should be automatically changed or adjusted at desired level based on control strategy. It is a feedback controlled system and actuator is controlled for the energy dissipation. External power is needed to operate this type of suspension. Actuator or sensors are added to this system to detect the road profile. Schema (Fig. 1.3) shows the basic components of semi active suspension system.

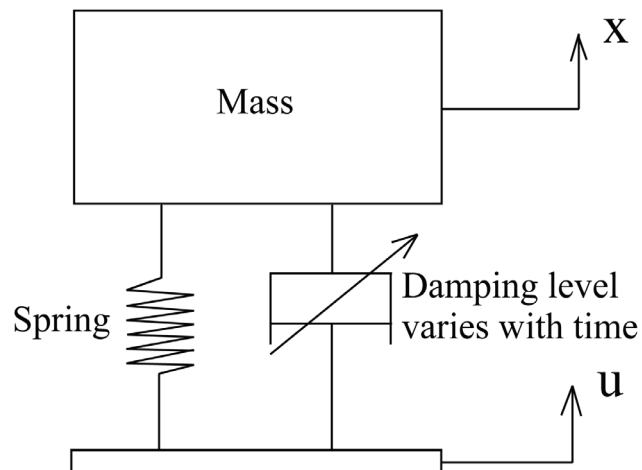

Fig. 1.3 Semi Active Suspension System

The behaviour of this system is non linear because of switching process and performance properties of semi active suspension is based upon the computer simulation. Such simulations are followed by frequency analysis in order to accurately represent the actual operation of such system. Control law must be derived for this simulation. Damping coefficient of shock absorber should be varied. Semi active suspensions are less expensive as compared to active suspension system and consume less energy.

1.5.1 Types of Semi Active Suspension System

1. Solenoid or valve actuated
2. Magneto rheological damper

1.5.1.1 Solenoid or Valve Actuated

This is a basic type of semi active suspension system. It consists of solenoid valve which is used to flow of hydraulic medium inside the shock absorber; therefore, it will need to change the damping characteristics of the suspension system. The solenoid is wired which is controlled by computer for sending the command depending on the control algorithms. Hydraulic dampers are designed in such a way that controlled force is proportional to the velocity. The controllable valve requires some characteristics in semi active suspension damper application. The solenoid valve handles the maximum velocity flow rate to the volume of fluid in the damper. The solenoid valve suspension system is simple in design and less expensive. Solenoid valve can be used for two or three dampers. Due to opening and closing the valves, the characteristics between the hard damping and soft damping should be changed. These dampers are used for improvement of the ride quality with appropriate control strategy. Figure 1.4 shows the basic components of solenoid valve.

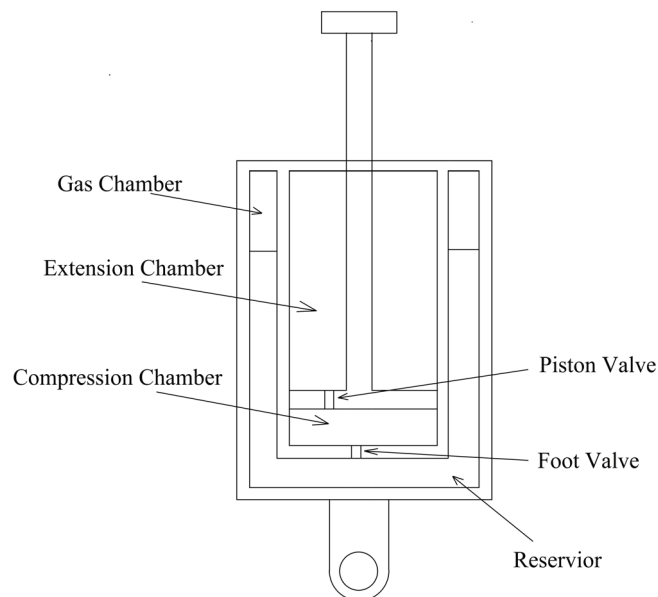

Fig. 1.4 Solenoid Valve Semi Active Suspension System

1.5.1.2 Magneto Rheological Damper

It was first developed by Delphi Lord Corporation and firstly semi active suspension system is upgraded and namely automatic road sensing suspension. The characteristics of damper are controlled by an electromagnet. It introduces the application of magneto rheological (MR) fluid for a controllable damper. MR fluid changes the rheological properties *i.e.*, elasticity, plasticity, viscosity, when magnetic field is applied on it. Small voltage and low current are required for the MR fluid. Therefore it has another name *i.e.*, smart fluid.

For control of vibration application, it is possible to apply the effect of hydraulic damper. The MR fluid controls the damping force by replacing mechanical valves. MR fluids are manufactured by ferromagnetic particles and kerosene oil, silicon oil and synthetic oil can be used for MR fluid. In the Semi active suspension, system-sensors continuously monitor the operating conditions of the vehicle body and according to the base excitement the signals obtained by the sensors and prescribed voltage applied across the flow (Rheological Fluid) of the fluid in a shock absorber, the damping force can be controlled. Due to control strategy, the force in the actuator is modulated to achieve improved ride and handling. Two basic technologies are used for MR damper modelling. These two technologies are Parametric model and Non parametric model. In Parametric model, Bingham model, Bouc Wen model and hysteretic model are used. In Non parametric model, Black Box Model (BBM) is used.

The minimum external power is required in the semi active suspension system. It has low cost and weight as compared to active suspension system. Semi active systems can only change the viscous damping coefficient of the shock absorber and do not add energy to the suspension system. It is a less expensive to design and consume less energy for operating the system.

1.6 BASIC MODEL OF QUARTER CAR MODEL

A quarter-car as the name suggests comprises of the quarter portion of the car. It consists of wheel, variable damper, damper and spring set.

Quarter car model of semi active suspension system is shown in Fig. 1.5. The mass acting on the suspension system can be classified into sprung mass (M_b) and

unsprung mass (M_w). The sprung mass (M_b) is the mass of body which is damped by suspension system. The value of the sprung mass is $1/4^{\text{th}}$ in case of quarter car model. The unsprung mass (M_w) is the mass of wheel, brakes *etc.* The suspension system *i.e.*, spring and damper are parallel to each other.

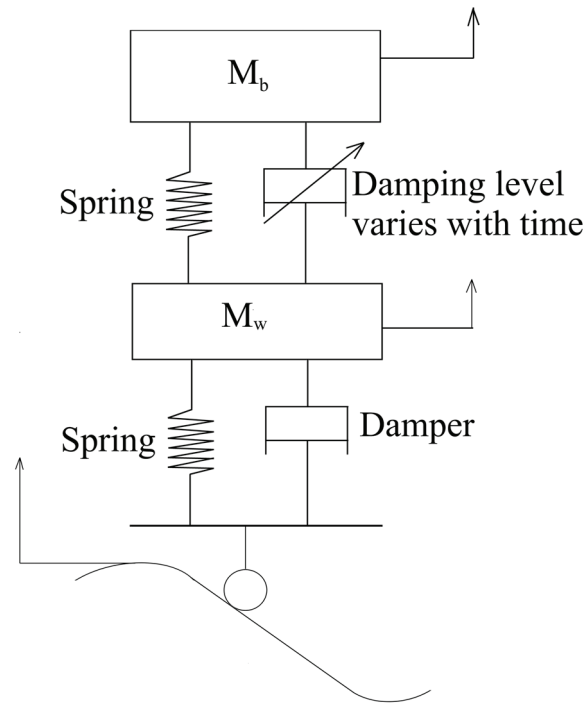

Fig. 1.5 Quarter Car Model of Semi Active Suspension System

1.7 SEMI ACTIVE CONTROL ALGORITHMS

The effect of the feedback control on the natural frequency, stability and its transient response is different in the dynamics of the system. These effects are carefully studied when a close loop control system is designed. Therefore a correct control algorithm is studied while designing the semi active suspension system. Another name of control algorithms is ‘brain’ of the semi active suspension system.

The control fundamentals (PID, adaptive and robust) are firstly provided on a variable structure control with a particular focus and then robust control algorithms may be analyzed. The semi active suspension damper control algorithms will be significance on balance logic (R-S control strategy).

The control algorithms can be classified into three groups

- PID controllers
- Adaptive controllers
- Robust controllers

1.7.1 PID Controller

PID controllers are Proportional Integral Derivative which is used in a wide range of application. To the known frequency domain and hypothesis of linearity of any system, this type of controllers are designed by the designer. If the hypothesis is very close to actual behaviour of system, these controllers work well. The linear system is defined in the frequency domain by its transfer function and as a result linearization of model. The actual response of PID controller depends on that how close the linear model represents the actual behaviour of system. Linear model depends on the sources *i.e.*, time delay of system, operating point changes, all parameters changes, input disturbance and modelled dynamics. PID controller does not perform well when its result is different from it has been designed and its performance should be optimized by using the robust design and adaptive control loop. A controller is said to be robust when its lower sensitivities is stable and always meet the specification, when a different parameter variation is used. Robust control design meets the control specification in the presence of uncertainties parameters.

By using the PID controller, several designs and tuning method are developed. The basic tuning methods are Ziegler and Nichols rules. The design of PID controller is based upon the linear frequency domain method and non linear control method namely adaptive and robust control algorithms.

1.7.2 Adaptive Control

The non linear system is used in adaptive control method. This control strategy is opposite to robust control. Adaptive controllers are used, when parameters of process are time varying. This method is based upon the estimated on uncertain parameters. The parameters are depends on the basis of measured plant signal. In that system, uncertain parameters are constant or slowly changes then control strategy are improved in their response.

The target of the adaptive control is to try the best performance in the system with unknown variation in its parameters. A controller with fixed parameter becomes inaccurate and unstable for large parameter variation then an adaptive controller is added to PID controller for improving the performance. The typical applications of adaptive control are Robotics, electrical power system or process control system. Two main approaches are used in adaptive controller. These two approaches are model-reference adaptive control and self tuning control. The first approach, model-reference control is used to set the ideal response of the system. Second approach *i.e.*, self tuning control method is used for the estimation of parameter by measuring the input and output of the system.

1.7.3 Robust Control

This control is meant to provide the reasonable level of performance in the system. The parameters are used as uncertain parameters for this control. The uncertain parameter in this system has no matter how the uncertainty parameter varies, but it requires the knowledge of bounds of uncertainty. The structure of robust law is composed of the feedback state or inverse model control and uncertainty model.

Robust control can be used with PID controller. It is associated with H_∞ control and variable structure control (VSC). The feature of VSC is that it changes the structure of system according to the assigned law. VSC is obtained by the switching on and scheduling gain. By using the VSC, it is easily to take the best out of several different systems by using the switching from one to another. The principles of adaptive and robust control are discussed. According to this principle no control system is more suitable for a particular type of system controlled. In broad, adaptive control perform better then robust control because adaptive control is work with constant or slowly varying parameters. The adaptive control improves the performance by using the adaptation procedure, whereas robust controller only attempt to keep good performance. Some advanced controllers are used for which the combination feature of adaptive or robust control strategy. This type of controller is known as robust adaptive controllers.

1.8 CONTRIBUTION OF THE THESIS

The main contribution of the thesis as follows:

- The detailed bond graph model of passive, skyhook and semi active suspension systems are developed.
- Bond graph model of bicycle vehicle model is developed and in this model, passive and semi active suspension systems are attached and a comparison of both the systems for evaluating the heave and pitch motion of vehicle is done.
- R-S control strategies are used in semi active suspension system to control the vehicle from varying road disturbance.
- Solenoid valve is modelled as a bond graph modelling technique and is used in bicycle vehicle model as semi active solenoid valve and the performance of vehicle is evaluated with the use of appropriate control strategy.

1.9 ORGANIZATION OF THE THESIS

The five chapters are included in this thesis. Overview and all information included into these chapters are given in the following:

A comprehensive literature review is presented in the Chapter 2. The literature pertaining to bond graph modelling of multi body system and bond graph modelling of vehicles system. The literature on semi active suspension system with different control strategies are also discussed in this chapter.

Chapter 3 details the principle of work of bond graph and suspension system. It gives details of the modelling of all multi body systems. Detailed review of bond graph with different energy domains and all bond graph elements are included. The model of skyhook, passive and semi active suspension systems are introduced and their transmissibility and output of each system are introduced in this chapter.

The bond graph model of semi active suspension system and bicycle vehicle model are developed in the Chapter 4. It includes the development and control of semi active suspension system. The bond graph model of bicycle vehicle model running at constant speed or electric vehicle modelled with passive system and semi active suspension system are presented in this chapter. The control strategy of semi active suspension or semi active solenoid valve is used to develop the vehicle performance.

Conclusions are presented in last chapter *i.e.*, Chapter 5. This chapter presents the list of all references. All the references are cited in this chapter of the thesis.

2.1. INTRODUCTION

In this chapter, the literature review on bond graph modelling, bond graph modelling of vehicle and semi active suspension system are presented. The bond graph modelling is used in vehicle dynamics and is best suitable for designing the mechatronic system. The literature on bond graph modelling of vehicle with semi active suspension system is discussed. In semi active suspension system various control strategies are used for making the best performance, ride comfort, vehicle stability for a four-wheel and bicycle vehicle model.

2.2. BOND GRAPH MODELLING

A bond graph is a graphical modelling tool which represents the system dynamics. It is useful for identification of system compared with sub systems in different energy domains. Bond graph is a more powerful in modelling system with different energy domain. Physical system is represented in bond graph by symbols, lines and identification of power flow path. Bond graph has been used in system with different energy domain and exchange information when sensor, actuator and control system are used in the model [1–3]. Bond graph are more powerful in modelling the complex system with interaction of different systems in several energy domains and the system can be modelled in a unified manner based on energy and flow of information [4]. It is a numerical tool to represent the systems structure. It is very flexible in modelling and formulates the equation of systems. Bond graph is formulation of classical system dynamics with many complicated structure and stimulates the imagination and abstract idea in integrated forms.

Bond graph modelling is suitable for designing the mechatronic system [5–6]. The virtual realities applications are used in this graphical system and simulation of various hardwires in loop are obtained by using modelling of bond graph [7–9]. The modelling of large systems is easily modelled by creating the sub model. After that each sub model is joined to form the actual system. Modelling of multi body systems are simplified in bond graph modelling [10]. Multi bond graph with kinetic loops is controlled and satisfies the equation of systems in different energy domains represented in bond graph [11]. Bond

graph model is used in mechatronic system for different applications. These applications relate the estimation, fault identification, fault detection *etc* [12–17]. The semi active suspension system with semi active solenoid valve, hydraulic actuator and six degree of freedom system (DOF) dynamics, four wheel vehicle and bicycle vehicle model with aerodynamic forces and tyre forces are introduced in bond graph approach.

2.3. BOND GRAPH MODELLING OF VEHICLES

Bond graph are best suitable for designing the mechatronic system for estimation, identification and fault diagnosis. Modelling and simulation of physical system are very important in engineering science. The main steps for modelling of physical system by using the bond graph are writing the equation for each physical system and then these equations are implemented in the solver. When the system is very complex and multi disciplinary, this approach is a time consuming for evaluating each parameter of physical system. Bond graph is a common tool as a unified approach to the physical modelling of various disciplines [18–21]. The simulation of vehicle is very important in study and research area. Three type of driving simulator *i.e.*, high level, medium level, and low level are used. High level simulator are those in which full vehicle system, large motion platform and 360 degree projection screen; in low level simulation simple cab, driving control and graphical method are used. Medium level simulator lies between the two simulators. Multi bond graph are best for representing the complex multi body system [10, 22]. The bond graph of any physical structure is controlled by the effective control algorithms [23–26]. Each physical system has its control policy to give the better performance of the vehicle.

Bond graph modelling is extremely used in vehicle dynamics [27–28]. The four wheel vehicle body with non linear dynamical model and controller with different control algorithms are modelled by bond graph approach. These control algorithms with electrically controlled brake and steering performance are developed in [29]. Three dimension dynamics of coupled body are developed by [30] and engine model with drive train model are developed by [31]. In full vehicle body with six degree of freedom for vehicle chassis and six degree of freedom of each wheel with tyre force are considered in [32] and these tyre forces are used to calculate the lateral, vertical and longitudinal forces

and motion. The vehicle model is able to receive all the driven inputs *i.e.*, steering angle, torque, gear change and accelerator *etc.* Bond graph is used to model the vehicle with different configurations *i.e.*, size, shape, weight, type of tyre, tyre pressure, type of brake, engine *etc.*

2.4 SEMI ACTIVE SUSPENSION SYSTEM

Shiao *et al.* [33] described the analysis and control of semi active suspension system for light vehicles and proposed a self tuning Fuzzy-controller for variable damping semi active suspension system. The components are designed in semi active suspension system to show non linear dynamic characteristic, Fuzzy controller. To make the system adaptive, the self tuning fuzzy controller is used with scale factor. By the use of Self Tuning Fuzzy controller with scale factor, the semi active suspension system have better performance to control the vehicle displacement, velocity, acceleration and frequency spectrum of acceleration.

Collette *et al.* [34] described the high frequency energy transfer in semi active suspension system. By using the sky hook algorithms, the isolation properties of a semi active suspension in a simple model of quarter car, show the isolation provided by the suspension degraded by non linearity of semi active algorithms and has a result to generate the high frequency components at harmonics of un-sprung mass resonance. This high frequency vibration generates noise through the excitation of flexible mode of vehicle. The semi active algorithms show the smooth variation to damping coefficient and the isolation at high frequency is greater than that of continuous semi active sky hook. By using the better damping of wheel resonance, the RMS value of sprung mass acceleration is reduced.

Mailat *et al.* [35] described an application of semi active system on automotive suspension. The vibratory behaviour of the system with motion dependent suspension force is considerably different than that of damping system with constant magnitude suspension force. In case of semi active, the damping force can be controlled and suspension force can be estimated during the motion. This problem is ill posed and optimization technique is applied to find the well posed problem. The solution is based upon the wavelet *i.e.*, (Haar wavelets). The wavelets are those approaches to find the

parameters for controlling and also for finding the good compromise between the performance criteria. Haar wavelets are better in comparing the performance to other approximation because it is simple to be applied, stable and at small cost time.

Leluzzi *et al.* [36] described the development process and overall performance of a semi active suspension control for a heavy truck. For this, control software is developed, debugged and preliminary tuned with Mat lab. After the preliminary evaluation, by using the rapid prototyping techniques application, the system performance is then tested on a real prototype truck. Experiment results show the goodness of development process and semi active damping strategy reaches the improvement in the comfort and handling. The improvement could be integration of time control system, ride comfort and handling. With the high band width actuator, installed on cabin suspension to dedicated as ride comfort and secondly placed on the frame suspension dedicated to the vehicle handling behaviour where low band width adjustable damper and frequency do not exceed 1-2 Hz.

Vassal *et al.* [37] described that the methodology for optimal performance of a semi active suspension system is evaluated both in terms of handling comfort and performance. To reach this aim semi active suspension system is modelled as the quarter car system with a controllable damper based on the theory of model prediction control and using the mixed integer programming. The passive suspensions have dual performance at low frequency, the better comfort performances are ensured and whereas the best comfort damping is low at mid and high frequency. This trade off can be overcome with an optimal control of damping. By the definition of methodology, this is useful for the benchmarking any of the semi active control algorithms with respect to the best performance.

Fang *et al.* [38] investigated that the semi active suspension system of a full vehicle model is based on double loop control. It was based upon on seven degree of freedom full body dynamics vehicle model with semi active suspension system. It consists of inner loop control and outer loop control. The inner loop controller was obtained by using fuzzy control method to isolate the sprung mass vibration from unsprung mass oscillation. The outer loop controller is obtained by the attitude of vehicle body as the principal source of control. Its linear control stabilizes the motion. A variable converter was also designed to connect the inner loop and outer loop and to complete the

coordinate control for a full vehicle. The simulation result shows that at the centre of gravity the semi active suspension system was more effective in the heave, pitch, roll acceleration of the vehicle body and greater performance index than that of semi active suspension system using fuzzy control and passive system under two kinds of road condition, white noise road input and bump input.

Vassal *et al.* [39] described the analysis of new semi active suspension controller through LPV (Linear Parameter Varying) technique. Semi active suspension control strategy that satisfies the principal limitation of a semi active suspension actuator is introduced by the Linear Parameter varying (LPV). A new approach which gives them some advantages *i.e.*, implementation, performance flexibility and robustness *etc.* are compared with already existing method. Such an approach is compared to existing ones for Flexible design, only possible way is to apply the pole placement, mixed criteria and for Measurement, only suspension deflection sensor is required and for Implementation, a solution tractable for any kind of semi active actuators is needed.

Eslaminasab *et al.* [40] described the non linear analysis of switched semi active controlled system. Semi active suspension system improves the suspension performance of the vehicles more effectively than that of passive system due to improving ride comfort and road handling. Semi active system also improves size, weight, price and performance advantage gained over the active as well as passive system. A semi active system neglects the on-off control strategy and adds the non linearity effect. The non linearity of on-off semi active control policy is discussed by using the one DOF system. To analyze and compare the performance of switched semi active controlled system, linearization method is needed to make the conventional performance index. R-S controlled system namely (method of averaging) is used to analyze the conventional semi active controlled system. The applicability and performance of the linearization method are discussed using the method of averaging. A modified semi active controller is used to eliminate the adverse effect of high harmonic for added non linearity. This new semi active control system can easily be adopted.

Ahmadian *et al.* [41] described the non dimensionalized closed form parametric analysis of semi active vehicle suspension using the quarter car model. This study evaluates the response characteristics of two degree freedom quarter car model by using

the passive and semi active dampers. The semi active vehicle suspension behaviour is evaluated using skyhook. Ground hook and hybrid control policy and compare with passive suspension. The relationship between suspension deflection, road holding and vibration isolation is studied and RMS value were used as measure of vibration isolation (comfort index), measure of road holding quality and measure of rattle space requirement. Hybrid control strategy gives the better comfort than a passive suspension, to increasing the suspension displacement and without reducing the road holding. Hybrid control policy gives the better comfort, road holding and suspension travel requirement than that of skyhook and ground hook policy.

Chen *et al.* [42] described the sliding mode control for semi active suspension with actuator dynamics. Sliding mode control gives the ride comfort and handling performance. The SMC is designed based on linear quarter car model with actuator dynamics parametric used in linear model obtained from the non linear McPherson strut suspension model. Kalman filter is designed on the linear model with actuator dynamics. The sliding surface consists of tyre deflection and sprung mass acceleration. The SMC can be suppress the tyre deflection and sprung mass acceleration while going on the speed bump. The sliding mode control system can reduce the sprung mass acceleration without increasing the tyre deflection, for the frequency response.

Igor *et al.* [43] described the control design of semi active seat suspension system. The vibration of semi active control strategy is based on the inverse dynamics of spring and damper element. The control system strategy discusses the overall structure of the semi active seat suspension. The vibro-isolation properties can be adjusted by the optimization procedure. Due to controller setting the stiff suspension can be converted into a soft suspension. The control system of semi active suspension allows finding dynamics behaviour of seat suspension by machine operator.

Hedrick *et al.* [44] described the analysis of active and semi active suspension for heavy truck to reduce the pavement damage. The effect of heavy truck suspension pavement is damaged by using the flexible pavement simulation program. It investigate that the dynamic effect of heavy truck suspension an pavement response and dynamics characteristics of active and semi active have been investigated to reduce the pavement degradation due to vehicle dynamics. The tyre force at all mode *i.e.*, low frequency

modes, short rocker mode, high frequency mode can be reduced by using the semi active suspension. The entire suspension reduces the pavement damage when compared with optimal passive suspension and performance of semi active suspension as good as active suspension.

Kamalakannan *et al.* [45] described the performance analysis and behaviour characteristics of semi active suspension in quarter car model. Semi active suspension uses an adaptive damper whose damping property varies with road condition under the influence of an electromagnet. The semi active suspension system uses the superior damping property over a wide load range. It also eliminates the compromise between the ride comfort and handling. Development of a simple and cheaper semi active suspension system is allowed to fit in affordable car.

Spelta *et al.* [46] described the experimental analysis and development of a control system of a motor cycle semi active rear suspension. The semi active electro-hydraulic controlled shock absorber used and locate in the rear suspension of the motor bike. A single sensor layout was designed for this kind of application. That strategy implemented in electronic control unit of bike test both on the test bench and on road.

Margolis [47] described the semi active heave and pitch control for ground vehicles. The semi active suspension is compared with totally active suspension and these systems are more superior to the passive suspension system. Control strategy is implemented for developing active suspension system and vehicle isolation is demonstrated. These active controllers are modified for implement the semi active system and superior vehicle isolation than active system. No power is provided to the vehicle from the controller. The heave pitch motion of two wheel vehicle is tested for frequency response. Result shows the better high frequency isolation of semi active suspension system than the passive and active suspension system.

Margolis [48] analyzed the semi active control of wheel hop in ground vehicles. Two degree of freedom vehicle is developed by composing of passive, active and semi active suspension system. By using the analytically understandable configuration, a linear model is used to compare the passive and active system. The semi active suspension is non linear system and compared with other computer simulation. Passive suspension system does not give better vehicle isolation of sprung and un-sprung weight. Active

system is compromised in provided both function. Semi active suspension is an excellent job than passive and active system.

Hassan [49] described the fundamental studies of passive, active and semi active automotive suspension system. These systems are investigated on basis of simple vehicle model subjected to input choose to represent road surface of different qualities. The vehicle response represents the comfort ride and dynamics tyre load with the implication of suspension design. Linear analysis method is used for development of passive and active suspension system and non linear method are best suitable for semi active suspension system. Linear optimal control theory is used to determine the optimal parameter of active suspension system. The behaviour of semi active suspension system is evaluated on the basis of optimal active parameters.

Witters *et al.* [50] described the black box model identification for a continuously variable, electro- hydraulic semi active damper for a passenger car. The non linear damper is described by the neural network output error (NNOE) model structure. For identify the system, optimal experiment design, model parameters and regression vector are estimate. Data measured from the optimized excitation is more accurate than the data obtained by using conventional random phase multi sine excitation.

Vassal *et al.* [51] described the survey and performance evaluation on some automotive semi active suspension control method *i.e.*, single corner model. The performance of semi active control policy is proposed control algorithms based on road holding and comfort performance, structure properties of the single corner model. The main interest of the presented result in a complete methodology is the bench marks of any semi active control algorithms. The suspension is modelled by using the single corner system and optimization problem which is based on the theory of model predictive control and mixed integer programming. The semi active suspension provides the great comfort performance and low complexity.

Song [52] described the cost effective skyhook control for semi active vehicle suspension application. Skyhook control is widely used in suspension controlling by using the sensors to measure sprung mass acceleration and relative displacement. These two measures are converted into velocity which is employed to decide the desired damping level. This system reduces the cost and improves the reliability of system by

using the semi active system. The model of full car suspension system is used to determine the effectiveness of one sensor which is used in skyhook control and passive suspension. The proposed skyhook gives better ride comfort performance than the traditional skyhook.

Rashid *et al.* [53] analyzed the development of a semi active car suspension control system using magneto-rheological damper model. The semi active suspension of an quarter car model is developed by using fuzzy based control. The quarter car model is described by two degree of freedom of non linear system which is excitation for different road profile. The suspension system is control by using the fuzzy controller and road model is used to control the force by the electromagnetic shaker. Magneto- rheological damper is used to adjust the damper. It is very effective to vibration control and control the damping force with small power supply. To provide the better vehicle isolation, road handling, and comfort for the ride quality in the semi active system, neural fuzzy logic and fuzzy hybrid controller are used in the system.

Ping *et al.* [54] described the integrated control of semi active suspension and vehicle dynamics control system. In semi active system, controlled damper and spring is used to improved the vehicle ride performance and vehicle dynamics control (VDC) are used in the system for stability of vehicle and handling through the traction control and braking forces vehicle dynamics model is based on ADAMS which is used to predict the dynamics performance of vehicle. For VDC, fuzzy logic controllers are used for semi active suspension. Skyhook controller is established by using the Matlab Simulink.

Georgiou *et al.* [55] described the multi- objective optimization of quarter car model with a passive or semi active suspension system. The multi objective methodology is applied in the suspension damping and stiffness parameters of two degree of freedom quarter car model. The optimization process is related to ride comfort, suspension travel and road holding of the vehicle, these techniques shows that the semi active system are more comfort for passenger than passive suspension system.

Valasek *et al.* [56] described that ground hook was the new concept of semi active control of truck's suspension. Ground hook is used in semi active system to minimize the tyre road forces. The main concept of ground hook is to decrease the criteria of road damage and increase the driver's comfort when road is unevenness. The control law

parameters are generally determined by non linear parameter optimization. The damping rate and time constant of shock absorber are taken into account.

Vanderaa *et al.* [57] described constrained optimal control of semi active suspension system with preview. The semi active suspension system is used in control strategy for improving the tyre force, damper range and suspension travel. Information on coming road elevation (preview) is available. The wheel forces and suspension travel are used in the quadratic performance index. The trade off between conflicting requirements has to make and constraint on tyre force and suspension travel play a role, with the semi active suspension system. Two approaches are used to handle this constraint *i.e.*, soft approach and hard approach. Soft approach does not work satisfy in optimal control strategy. The hard constraints approach handles this situation because it gives the non linear performance of a semi active suspension with preview.

Mori *et al.* [58] described that the adaptive semi active control of suspension system with magneto-rheological damper. The proposed model consists of two adaptive controls: first is adaptive inverse control and second is adaptive reference control. The non linear hysteretic dynamics of the magneto-rheological damper is controlled by adaptive inverse method which can be realized by identity the forward model of MR damper and calculate the input voltage to generate the reference damping force. The adaptive reference control gives the desired damping force to a reference dynamics in the presence of unknown mass and spring constant.

Lauwerys [59] described the design of controller for active and semi active suspension system for passenger's cars. The design focus is lead to flexible and tunable control structures of the system. The control design method is applied in inner loop for linearizing the system and outer loop is better in the system dynamics. The linearization of inner loop is based on non linear input transformation and outer loop control is designed by robust control design method based on H_∞ and μ -synthesis. For developing the semi active suspension system, flexible and transparent control structure is used to improve the comfort and vehicle handling performance.

Rao *et al.* [60] described the analysis of passive and semi active controlled suspension for ride comfort in an omnibus passing over a speed bump. The modelling and testing of skyhook and semi active suspension control strategies are developed. The

control policy of three degree of freedom quarter car model with semi active suspension system is developed in the Matlab. A parameter adaptive suspension control for designing is developed after review the condition of different suspension control. Comparing the performance of passive, skyhook, modified skyhook, the modified skyhook control has high reduction of peak displacement than passive system and modified skyhook method has optimum robust solution in term of human comfort.

Kyongsu *et al.* [61] described the observer design for automotive semi active suspension control. Semi active suspension system shows the bilinear model and an observer is described that estimation errors are independent of unknown external disturbance. The proposed observer easily measures the acceleration, suspension deflection and velocities. Therefore, the semi active suspension is described with good accuracy by proposed observer. The sprung and un-sprung mass velocity can easily be evaluated by using the proposed observer. The observer controller performed very well for improvement of ride quality and comfort.

2.5 LITERATURE GAP

After doing detailed study of literature on vehicle dynamics, bond graph modelling, semi active suspension, it is known that many researchers have worked on semi active suspension. They have also developed different control strategies for the suspension. As per my knowledge I have come to know that no researcher has used bond graph aided model of semi active suspension *i.e.*, solenoid valve damper which may be used in the vehicle to enhance safety, traffic management and space optimization inside the confined space. So, research may be carried on bicycle vehicle model with semi active suspension system. Different control strategies are used in vehicle model for control the vehicle and improve the performance of vehicle with ride comfort, vehicle stability, road disturbance.

2.6 OBJECTIVE OF THE PRESENT WORK

According to the literature review, it is found that bond graph method is useful for modelling the control algorithms and simulation of physical system of vehicle. By using the bond graph modelling of bicycle vehicle model with semi active suspension is discussed for bump excitation to the front and rear wheel of vehicle. Therefore, the lack

of literature is analysis and control of semi active suspension for a heavy vehicle. The objective of present work is formulated and summary of these objectives are:

- To develop the bond graph for a complex multi body physical system.
- To develop the bond graph in modelling of system with different energy domain
- To develop the control strategy of semi active suspension system such as R-S control.
- To test the control performance while vehicle used passive suspension system and semi active solenoid valve.
- To test the control performance of bicycle vehicle model which is used to developing the vehicle model with road condition, parameters and engine parameters.
- To develop the performance of semi active solenoid valve.
- To develop the model of heave and pitch motion of bicycle vehicle model.

3.1 INTRODUCTION

Bond graph is extremely used in the vehicles dynamics study and best suitable for designing the mechatronic system for estimation, identification and fault diagnosis. The bond graph has been used in the system lying in different energy domains and exchanges the information when different sensors and control systems are used in the model. The main steps for the modelling of system by using the bond graph are writing the equation for each physical system and then these equations are solved in the solver. Passive, skyhook and semi active suspension systems are modelled by using the bond graph in this chapter. Transmissibility and outputs of passive, skyhook and semi active suspension systems are plotted with appropriate control strategy. Results show that semi active suspensions are better than the passive suspension system. Semi active suspension system improves the ride comfort, vehicle stability and handling of the system.

3.2 BOND GRAPH

Bond graph is a graphical modelling tool which is a pictorial representation of different dynamics of system. Bond graph represents the bidirectional flow for the energy of any physical system. Bond graph is similar to block diagram or signal flow graph of any physical system. But the block diagram and signal flow graph represent the unidirectional flow information of physical system. Bond graph is used to identification of simple and complex system which is composed of sub systems or sub models with different energy domain and exchange the information when control system, sensors, and actuator are included in the model. Bond graph is used to formulate the system dynamics with many complexities in it; is simulated due to imagination of modeler and gives ideas in integrated form. The physical systems are represented in bond graph form by symbols, lines and identification of power flow path.

Bond graph is more powerful in modelling of complex systems with interaction of several energy domains. It is a graphically representation of physical systems with dynamics forces. Bond graph is neutral and multi domain system. Bond graph is

composed of bond of each element. Bond consists of single port, double port and multi port of each element. Each bond has its own flow of energy and power. Bond graph is used in mechatronic systems for estimation, identification, fault detection *etc.* The bond inter-connects the lumped parameter elements *i.e.*, resistance, capacitance, and inertance in a systematic form and computer can be performed to do it. ENPORT, SYMBOLS Shakti, Camp-G, Dymola, 20-sim are the software to perform the modelling and simulation of physical systems. Each bond has its own power variable. For example, the bond graph of a mechanical system represents the flow of mechanical energy and their power variables are represented as force and velocity. The power variable of each system is divided into two types *i.e.*, effort (e) and flow (f). In each system, effort is multiplied by flow to produce the power. In bond graph modelling power is transmitted between converted component by the combination of generalized effort & generalized flow in different physical domains. Power is always used as generalized coordinate to model systems in different energy domains. In different systems, the example of efforts are force, torque, voltage or pressure and example of flows are velocity, current, volumetric flow, volume change rate *etc.* Table 3.1 shows the power variables are used in different energy domain.

In bond graph theory basic elements are represented by I, C, and R. Source of inputs are represented by SE or SF. The portrayal systems represent the constrained structure and binding the atomic elements or sources. The elements are connected by line segments called bond. The bond gives the path of power within the structure. In bond graph symbols can be divided into four groups:

1. Three basic single port passive elements *i.e.*, inertance (I), capacitance (C) and resistance (R).
2. Two basic active source elements *i.e.*, source of effort (Se or SE) and source of flow (Sf or SF).
3. Two basic two port conversion elements *i.e.*, gyrator (GY) and transformer (TF).
4. Two basic junction elements *i.e.*, constant effort junction (0) and constant flow junction (1).

Table 3.1: Power Variables in Different Energy Domains

Systems	Efforts (e)	Flow (f)
Mechanical	Force (N)	Velocity v ($m \cdot s^{-1}$)
	Torque τ ($N \cdot m$)	Angular velocity ω ($rad \cdot s^{-1}$)
Hydraulic	Pressure p ($N \cdot m^{-2}$)	Volume flow rate \dot{Q} ($m^3 \cdot s^{-1}$)
Electrical	Voltage (V)	Current (i)
Thermal	Temperature (K)	Entropy change rate \dot{s} ($W \cdot K^{-1}$)
	Pressure ($N \cdot m^{-2}$)	Volume change rate \dot{v} ($m^3 \cdot s^{-1}$)
Chemical	Chemical potential μ ($N \cdot m \cdot mol^{-1}$)	Mass flow rate ($mol \cdot s^{-1}$)
	Entropy h	Mass flow rate \dot{m} ($kg \cdot s^{-1}$)
Magnetic	Magnetic- motive force (A)	Magnetic flux rate ($Wb \cdot s^{-1}$)

The basic variables are the effort (e), the flow (f), time integral of effort (p) and time integral of flow (Q). The assignment of power direction may be fixed at the coordinate system. The power direction is shown by half arrow at the end of bond. The assignment of bond number is fixed as the name of elements and junction. Table 3.2 gives the definition of bond graph [62]. The transformer element is different from some other work. The transformer does not create or store energy.

In bond graph, power is transmitted between the different components of system by the combination of effort and flow. The word bond graph defines the system as well as sub system. Figure 3.1 shows the word bond graph of engine to wheel. Engine is connected to a wheel through the shaft and power is transmitted in mechanical domain. In mechanical domain, effort is torque (τ) and flow is angular velocity. Half arrow shows the sign convention and the value of τ and ω are in positive when engine is doing any work. Figure shows that engine gives power to wheel and wheel gives some output, *i.e.*, τ and ω are positive in nature.

Table 3.2: Definition of Bond Graph Elements

Type	Name	Symbol	Definition	
			Linear	Nonlinear
Storages	Inertance		$f = \frac{1}{m} \int_{-\infty}^t e dt$	$f = \psi_I \left(\int_{-\infty}^t e dt \right)$
			$e = m \frac{df}{dt}$	$e = \phi_I \left(\frac{df}{dt} \right)$
	Capacitance		$e = K \int_{-\infty}^t f dt$	$e = \phi_C \left(\int_{-\infty}^t f dt \right)$
Dissipation	Resistance		$f = e / R$	$f = \psi_R (e)$
			$e = R f$	$e = \phi_R (f)$
Transducers (ideal)	Gyrator I		$e_2 = r f_1$ $e_1 = r f_2$	$e_2 = r(x) f_1$ $e_1 = r(x) f_2$
	Gyrator II		$f_1 = \frac{1}{r} e_2$ $f_2 = \frac{1}{r} e_1$	$f_1 = \frac{1}{r(x)} e_2$ $f_2 = \frac{1}{r(x)} e_1$
	Transformer I		$f_2 = \mu f_1$ $e_1 = \mu e_2$	$f_2 = \mu(x) f_1$ $e_1 = \mu(x) e_2$
	Transformer II		$f_1 = \frac{1}{\mu} f_2$ $e_2 = \frac{1}{\mu} e_1$	$f_1 = \frac{1}{\mu(x)} f_2$ $e_2 = \frac{1}{\mu(x)} e_1$
Sources	Source of effort		$e = e(t)$	
	Source of flow		$f = f(t)$	
Junctions	Zero (0)		$e_1 = e_2 = e_3$ $f_1 + f_2 = f_3$	
	One (1)		$f_1 = f_2 = f_3$ $e_1 + e_2 = e_3$	



Fig. 3.1 Word Bond Graph of Engine to Wheel

Figure 3.2 shows the word bond graph of wheel sensor. According to this figure, full arrow shows the signal bond and is used to measurement any output from the wheel. The power is flowing through the signal bond significantly and is used to calculate the motion of any physical system. The amount of any information from wheel is measured by using the sensor connected to wheel. Techometer is used to measure the RPM of the wheel.



Fig 3.2 Word Bond Graph of Wheel Sensor

3.2.1 JUNCTION

In bond graph, there are two kinds of junction *i.e.*, 0 junction and 1 junction.

- In 0 junction, sum of flows are zero and efforts are same. According to this junction, all the forces are equal in all the electrical and mechanical or any other systems.
- In 1 junction, sum of efforts are zero and flows are equal. It correponds to the electrical loop, or in mechanical system force is bilinear at a mass.

3.2.2 CAUSALITY

Bond graph has a notion of causality [63] and bond determines the instantaneous effort and instantaneous flow. Causality defines the effort and causes relationship between two factors of power. If the system is energetically closed, the notion of causatiuon is used to define the predictive relation in the form of differential or integration equation or in the combination of both. The physical system model is limited in such a way that greater part of universe remains outside its boundaries from which it imparts power or reject to it [63]. The notion of causality defines in all aspects *i.e.*, integration with exterior, storage or constraints. The flow of information *i.e.*, input and effort information *i.e.*, output of physical system are determined by causal stroke which is shown by the small transverse line at the end of bond in bond graph. The generalized effort and generalized flow signals are directed towards the causal stroke at the end of bond. An example of causality is

show in Fig. 3.3. Figure 3.3(a) shows the exchange of power between the A and B elements and Fig. 3.3(b) shows the causality of these two elements in bond graph theory. Two elements or junction are connected by bond. Figure shows that A receives the flow information and gives the effort information to B and on the other hand, B receives the effort and gives flow to A.

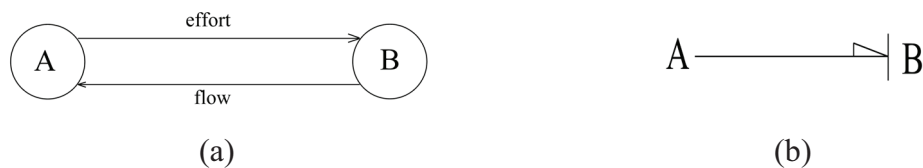

Fig. 3.3(a) Exchange of Power and (b) Causality in Bond Graph Representation

The proper causality elements (I or C) *i.e.*, inertance or capacitance elements also are called the independent energy storage elements which yield to state variable. This causality is called integral causality *i.e.*, the causes are integrated to generate the effect. The state variable in bond graph is generalized momentum (p) and generalized charge (q).

The relationship of causality is symmetric relationship. One side of system causes the effort and other side causes the flow. Active component of a system represents the voltage or current source. These two sources are causal in nature. A causal stroke *i.e.*, input of system are added to one side of power bond and output is represented at another side of bond. This side called the effort of the system. Let us consider that a motor gives torque to drive the wheel *i.e.*, also known as source of effort (SE). Figure 3.4 shows the word bond graph of motor to wheel.

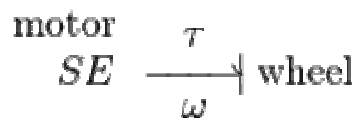

Fig. 3.4 Word Bond Graph Motor to Wheel

The side of wheel is known as causal stroke which indicates the effort for the bond. In the system, only one end of power bond and one end of bond can define the effort and causal stroke. The time dependent components of system *i.e.*, inertance I and capacitance C can have only one port of causation. I component determines the flow and C component determines the effort of the system. J is the any junction and describes the

legal configuration for I and C elements. Figure 3.5 show the proper causality of inertia and compliant element.

$$J \text{ ---} \downarrow I \quad \text{and} \quad J \text{ ---} \uparrow C$$

Fig. 3.5 Causality of Inertia and Compliant Element

The inertia or I element defines the causes as effort and gives flow *i.e.*, velocity or current. Therefore, in compliant or C element defines the causes as flow and gives the effort *i.e.*, force or voltage *etc.*

A resistor R is not a time dependent variable, therefore, it applies voltage or force *i.e.*, efforts are applied on the system and flows *i.e.*, velocity or current are obtained. The resistor applies the velocity or current (flow) on the system and effort (force or voltage) is obtained. The causality of R element is shown in Fig. 3.6. R element does not introduce any improper causality in the model system. R element has a flexible causal structure. It has two forms: Junction causalled form and Element causalled form. The junction causalled form in bond graph is shown in Fig. 3.6(b) and element causalled form in bond graph is shown in Fig. 3.6(a).

$$J \text{ ---} \downarrow R \quad \text{and} \quad J \text{ ---} \uparrow R$$

(a) (b)

Fig. 3.6 Causality of R element

Transformer does not dissipate or store any energy. In the transformer, there are two power ports and bonds are connected. The flow of one bond is converted into flow of another bond. Likewise, the effort on one bond changes to effort of another bond. Transformer gives flow to flow and effort to effort in the model. The causality of transformer is shown in Fig. 3.7.

$$\text{---} \downarrow \dot{T} \dot{F} \text{ ---} \quad \text{or} \quad \text{---} \dot{T} \dot{F} \text{ ---}$$

Fig. 3.7 Causality of Transformer

Gyrator is also a two port ports or bonds element. In gyrator, the flow in bonds is proportional to the effort in another bond and effort of one bond is proportional to the flow of other bond. Therefore, in gyrator, flow changes to effort and effort changes to

flow. In gyrator, flow is causalled in one side and effort is causalled in other side. Figure 3.8 shows the causality of gyrator.

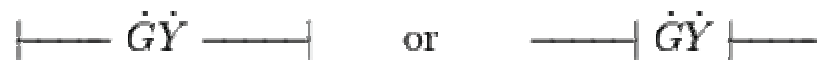

Fig. 3.8 Causality of Gyrator

In bond graph, efforts are equal in 0 junction and flows are equal in 1 junction. Therefore, the causality of bond in 0 junction only one bond has effort causality. In 1 junction only one bond has flow causality. If the causality of one junction bond is known, the causality of another junction is also known. This bond is called the strong bond and other bonds along with the strong bond are called the weak bond. Figure 3.9 shows the causality of junction element.



Fig. 3.9 Causality of Junction Element

3.2.3 ACTIVATION

In bond graph, bond gives the exchange of power and information to the flow or effort. Some bond in bond graph gives only exchange of information. This type of bond is also called an activated bond. There are two types of activated bonds: flow activated bond and effort activated bond. These bonds are not power bonds, which mean that these types of bonds do not interact with the system. This type of bond represents the velocity, force information, acceleration, displacement and any type of motion in the system and in the bond represent a force sensor and information of flow must be masked. In the causal stroke, a full arrow shows that some information is passed and some information is masked (refers to Table 3.3).





3.2.4 SENSORS AND ACTUATORS

In bond graph, pseudo state is used to measure any power by using the pseudo storage elements. A flow activated C element which shows integral causality would observe the flow. An effort activated I element which shows the integral causality would observe the effort and consequently generalized momentum. The integrally causal C element shows

the Df *i.e.*, detector of flow and I element shows the De *i.e.*, detector of effort. These elements do not interfere in the dynamics of the system. The symbols for the effort and flow detectors are shown in Table 3.3 [62]. Detector Df and De are weak bond at the connected junction. Therefore, the flow detector is usually connected to 1 junction whereas the effort detector is usually connected to 0 junction.

Activation bonds are used in modulated sources and non linear relation of one port and two port elements. These are called modulated sources. One port and two ports elements and their bond graph notation are given by prefixing M. The output of any physical system is determined by using the signal from sensor (*i.e.* detector of flow Df and Detector of effort De) through the activation bond from the junction. MSe and MSf are emanating the modulator source of effort and flow, whose output depend on the type of modulating signal. If modulating signals are more, outputs are more; if signals are less, outputs are less. If the modulated signal has two ports *i.e.*, modulated transformer MTF and modulated gyrator MGY, the modulated signal input is going to two ports besides it two powers.

Table 3.3: Definition of Signal Bonds and Sensors

Name	Type	Symbol	Definition
Signal Bond	Effort		$e = e(t), f = 0$
	Flow		$f = f(t), e = 0$
Sensors (Detectors)	Effort	 De : e	$e = e(t), f = 0$
	Flow	 Df : f	$f = f(t), e = 0$

3.2.5 DIFFERENTIAL CAUSALITY

The reverse of an integrated causal orientation on storage element is called the differential causality or also known as differential causal orientation. The causal structure of junction elements does not allow more than one strong bond. The R elements have flexible causalities, therefore, these elements are avoiding in that situation. But model showing the reverse causal orientation, may be avoided without using the extension or reduction of the model. On the other hand, differential causality arises in the system, when storage elements are not dynamically independent. The parameter of these storage

elements do not appear in equation. Differential causality of an element C and I is shown in Fig. 3.10.

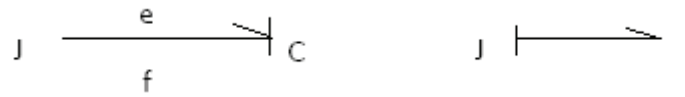

Fig. 3.10 Differential Causality of C and I Element

3.2.6 EXAMPLE ON ASSIGNMENT OF CAUSALITY

A spring mass system and its causalised bond graph are shown in Fig. 3.11.

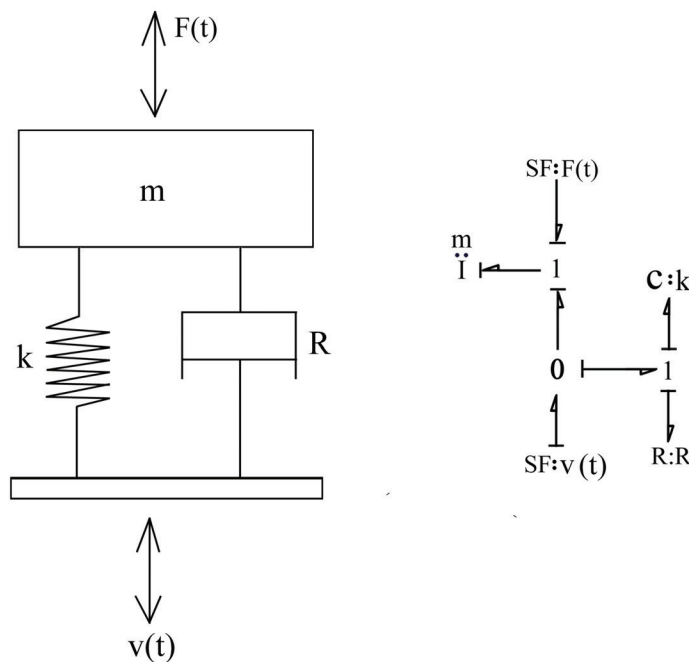

Fig. 3.11 Spring Mass System and its Causalised Bond Graph

3.3 PASSIVE SUSPENSION SYSTEM

The passive suspension system with single degree of freedom is used on heavy vehicles. Components of passive system are spring and damper and these components are fixed in nature. Their characteristics are determined by the design of suspension system for achieving the desired goals. The design of the passive system is to achieve the compromise between the vehicle handling and comfort ride. The passive suspension system with single degree of freedom is modelled as shown in Fig. 3.12.

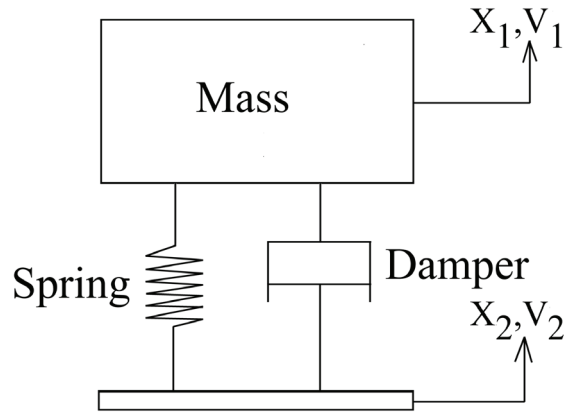

Fig. 3.12 Passive Suspension System

Two basic elements used in passive system are spring and damper. Spring is used as energy storing element and can be used to control the static weight of system. Damper dissipates the energy. The bond graph model of passive suspension system is shown in Fig. 3.13. The line with half arrow shows the power bond and full arrow shows the information bond. The $(I : m_b)$ are inertia of body which lies in moving frame and converted into the inertial frame by pseudo forces.

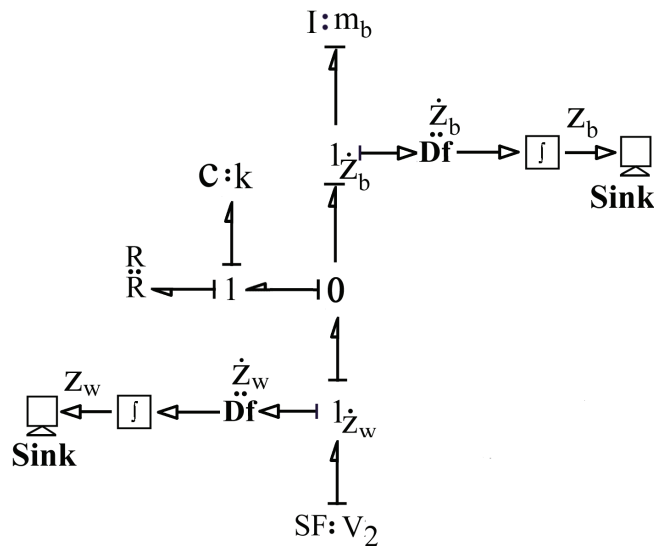

Fig. 3.13 Bond Graph Model of Passive Suspension System

The flow detector *i.e.*, Df is used to know the velocity and displacement of suspension system. In bond graph model the flow V_2 called the SF is also known as source of flow which are applied as input to the suspension system through wheel. The stiffness of spring k and resistance R are attached at 0 junctions in bond graph. The

transmissibility of the system can be calculated using bond graph model. From the bond graph model, the equation of motion of passive suspension is given by

$$m_b \ddot{X}_1 + k(X_1 - X_2) + c(\dot{X}_1 - \dot{X}_2) = 0 \quad (1)$$

If $z = X_1 - X_2$, the overall solution of above expression is

$$z = Ze^{-\zeta\omega_n t} \sin(\sqrt{1-\zeta^2} \omega_n t - \phi) \quad (2)$$

The transmissibility of passive suspension system is given by

$$\frac{X_1}{X_2} = \sqrt{\frac{1 + 2\zeta \frac{\omega}{\omega_n}}{\left[1 - \left(\frac{\omega}{\omega_n}\right)^2\right]^2 + \left[2\zeta_s \left(\frac{\omega}{\omega_n}\right)\right]^2}} \quad (3)$$

Where, ζ is the damping ratio of passive suspension system. Figure 3.14 shows the transmissibility with ω/ω_n for various damping ratio for a SDOF passive suspension system. Table 3.4 shows the parameter values those are used for simulation of the transmissibility of passive suspension system.

Table 3.4: Parameter Values of Passive Suspension System

$k = 2000 \text{ N/m}$	$m_b = 20 \text{ kg}$	$\zeta = 0.2 \text{ to } 1.2$	$\omega = 0 \text{ to } 50 \text{ rad/s}$
------------------------	-----------------------	-------------------------------	---

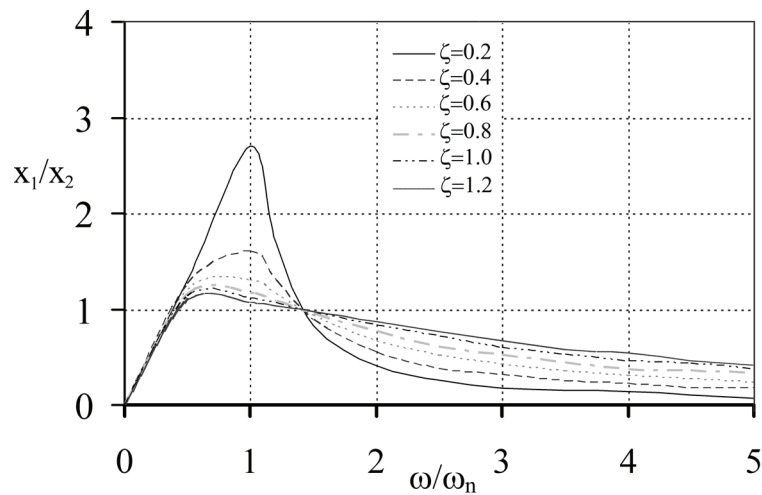

Fig. 3.14 Transmissibility of Passive Suspension System

Transmissibility shows that when damping ratio (ζ) is low, the resonant transmissibility is high. But when damping ratio is high, then frequency transmissibility is quite low. At low damping ratio, the resonant transmissibility is quite high but frequency transmissibility is quite low. On increase the damping ratio, tradeoff occurs between the resonant and frequency transmissibility.

3.4 SKYHOOK SUSPENSION SYSTEM

To eliminate the tradeoff between the resonance and frequency transmissibility, an ideal skyhook suspension system may be used. Figure 3.15 shows the ideal skyhook suspension system. In skyhook system, damper is attached at the inertial reference in the sky *i.e.*, fixed in the vertical direction.

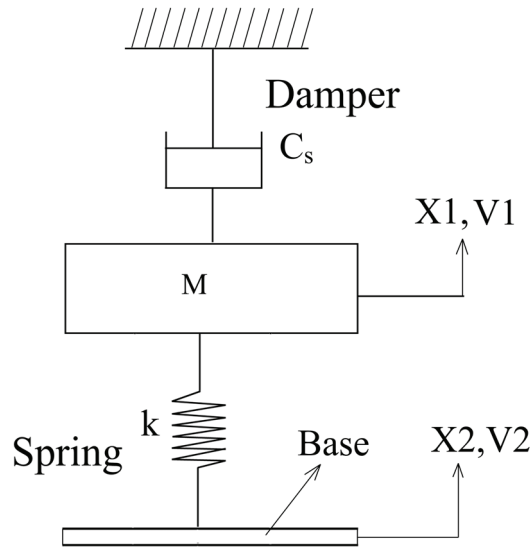

Fig. 3.15 Ideal Skyhook Suspension System

The mass acting on the suspension system called the sprung mass which is connected between the damper and spring of the system. Spring is attached at the base excitation of the system. X_1 and X_2 are used to know the displacement and V_1 and V_2 are used to know the velocity of the system. The transmissibility of skyhook suspension system is shown in Eq. (4).

$$\frac{X_1}{X_2} = \frac{1}{\sqrt{\left[1 - \left(\frac{\omega}{\omega_n}\right)^2\right]^2 + \left[2\zeta_s \left(\frac{\omega}{\omega_n}\right)\right]^2}} \quad (4)$$

In this equation, ζ_s is the skyhook damping ratio. The bond graph model of skyhook suspension system is shown in Fig. 3.16. The half and full arrow line show the power and information bond respectively. Information bond gives the displacement and velocity of the system. m_b be the inertia of the body. The only difference in passive and skyhook system is that, in passive system, resistance element are attached at spring and in skyhook system, resistance element, R element is attached at the inertial reference of sky above the mass of body. Df, detector of flow bond is used to indicate the information *i.e.*, displacement, velocity *etc.*

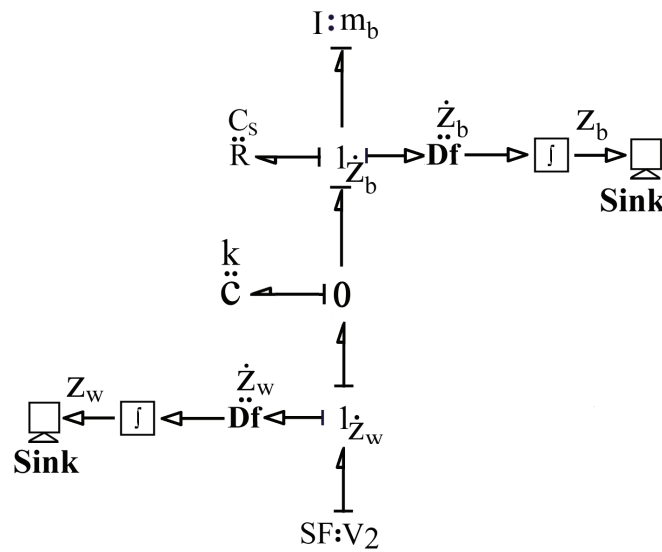

Fig. 3.16 Bond Graph Model of Skyhook Suspension System

Figure 3.17 shows the transmissibility with ω/ω_n for the skyhook suspension system. It shows that the increase of damping ratio, removes the tradeoff resonant and frequency transmissibility because the transmissibility does not increase. Skyhook suspension is an optimal control strategy but this is not an actual system. This system can be assumed. The optimal control policy indicates that its ability to isolate the suspended mass from the base excitation. To improve the damping force, the passive suspension system *i.e.*, spring and damper can be removed and replaced it with a force generator. This system is called the active suspension system but this system is very complex and requires a large amount of power. Therefore, another method of improving the skyhook damping force is semi active damper.

Table 3.5 shows the parameter values those are used to simulate the transmissibility of skyhook suspension system.

Table 3.5: Parameter Values of Skyhook Suspension System

$k = 2000\text{N/m}$	$m_b = 20\text{ kg}$	$\zeta = 0.2\text{ to }1.2$	$\omega = 0\text{ to }50\text{ rad/s}$
----------------------	----------------------	-----------------------------	--

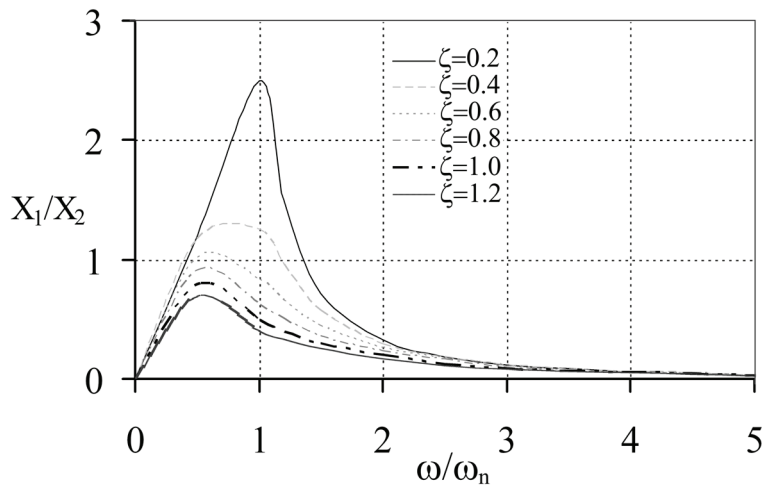

Fig. 3.17 Transmissibility of Skyhook Suspension System

3.5 SEMI ACTIVE SUSPENSION SYSTEM

In semi active suspension system, the damping coefficient can be changed between the high and low level of damping value. Fig. 3.18 shows the single degree of freedom semi active suspension system. The bond graph model of semi active suspension system is shown in Fig. 3.19. According to this system, the damping coefficient is change with time *i.e.*, R element is replaced with some source of effort SE. It is used to change the damping coefficient of the system. V_2 is used as input given to the system by road disturbance. In bond graph, k_w be the stiffness of the tyre of the wheel and k is the stiffness of spring. m_w is the inertia element of the wheel and m_b is the mass of the vehicle body as shown in the bond graph. The bond graph model is used to calculate the transmissibility of the system.

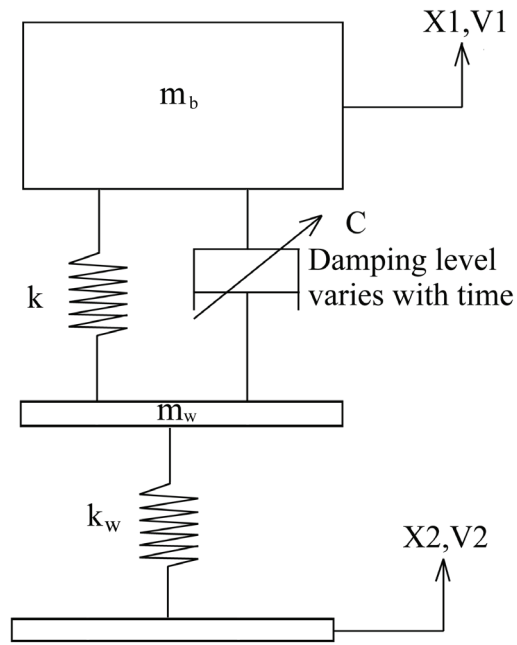

Fig. 3.18 Semi Active Suspension System

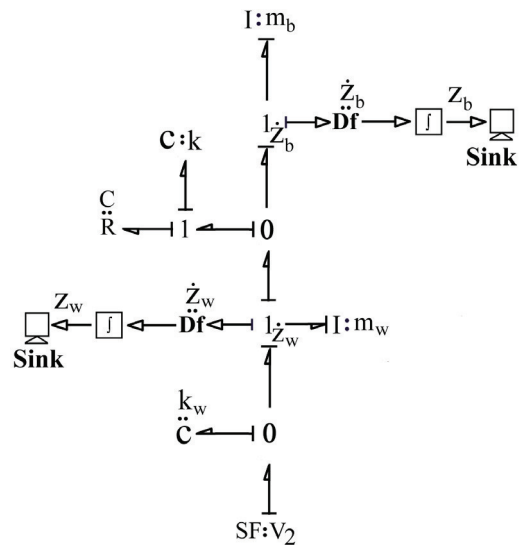

Fig. 3.19 Bond Graph Model of Semi Active Suspension System

The control policy for controlling the damping force (F_s) of semi active system as written in Eq. (5) is given by

$$\begin{aligned}
 F_s &= CV \quad \forall V_1 V_{12} > 0 \\
 &= 0 \quad \forall V_1 V_{12} < 0
 \end{aligned}
 \tag{5}$$

Figure 3.20 shows the transmissibility of semi active suspension system as function of ω/ω_n . Table 3.6 shows the parameter values used for the simulation of transmissibility of semi active suspension system.

Table 3.6: Parameter Values of Semi Active Suspension System

$k = 2000\text{N/m}$	$m_b = 20\text{ kg}$	$\zeta = 0.2\text{ to }1.2$	$\omega = 0\text{ to }50\text{ rad/s}$	$F_{\min}/F_{\max} = 0.1$	$m_b/m_w = 5$
----------------------	----------------------	-----------------------------	--	---------------------------	---------------

The transmissibility graph shows that on decreasing the damping ratio ($\zeta = 0.2$), the resonant transmissibility becomes quite high and on increasing the damping ratio ($\zeta = 1.2$), the resonant transmissibility becomes quite low. This low transmissibility should be lower than that of passive suspension system. Therefore semi active suspension system is better than the passive suspension system.

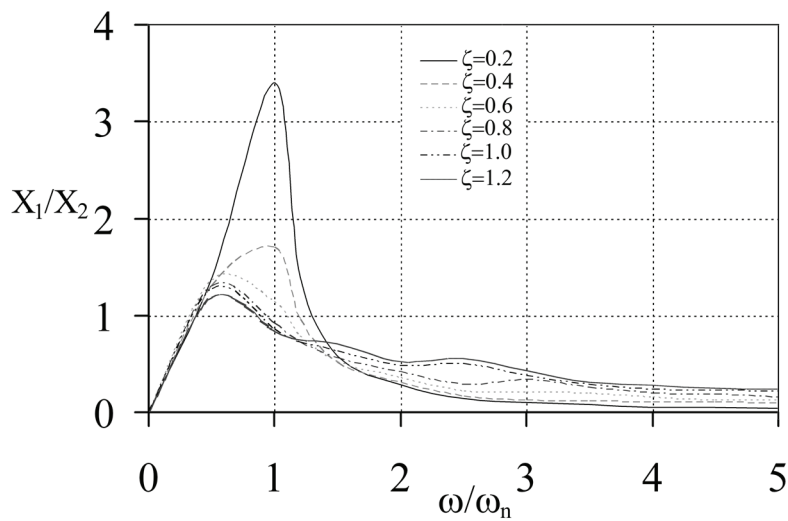

Fig. 3.20 Transmissibility of Semi Active Suspension

4.1 INTRODUCTION

This chapter introduces the planar vehicle model with passive, semi active suspension system and semi active solenoid valve damper. Bond graph model of planar vehicle with passive, semi active system and semi active solenoid valve is developed. Heave and pitch motions are considered to compare between the passive and semi active system and this compares the system which provides better isolation for the heavy vehicle model. Semi active solenoid valve is introduced for better comfort and vehicle handling for a vehicle model. This is hydraulically actuated damper and used for better performance of vehicle. In bond graph model of vehicle body, a capsule (sub-model) of semi active solenoid valve is used. Result shows that the use of semi active solenoid valve, gives better vibration isolation and vehicle stability and handling.

4.2 PLANAR VEHICLE MODEL

A bicycle model of the vehicle was used for the initial study. This model does not take into account the roll, yaw and sway motions but the suspension dynamics is considered. Thus, the load transfer during maneuvering cannot be included in this model. The semi active systems that are attached in the front and rear wheel of the planar vehicle body are shown in Fig. 4.1. Support parameters that are used in the vehicle are estimated and their response to road excitation is studied. The bond graph of this schematic vehicle is shown in Fig. 4.2.

The bond graph model of the planar vehicle system is a standard example, which is found in the introductory chapters of any book on bond graph modelling. The vehicle is supported by the front and rear wheels through suspensions. A bump of length l and height h excites the vehicle as it passes over bump. The initial distance of the car from the bump is d_1 . It is assumed that the vehicle goes over the bump at a constant speed v , without slowing down. The distances between the front and rear suspension system from the centroid are a and b , respectively.

4.2.1 Kinematic Relation

The kinematic relations are used to construct a major part of the model. It is assumed that bicycle vehicle model lies in the x-z plane. Therefore the normal and tangential velocity of the front suspension reference point is

$$\left. \begin{aligned} v_{\text{nfr}} &= (\dot{z} + \dot{\theta}_{cy} a) \\ v_{\text{tfr}} &= \dot{x} \end{aligned} \right\} \quad (4.1)$$

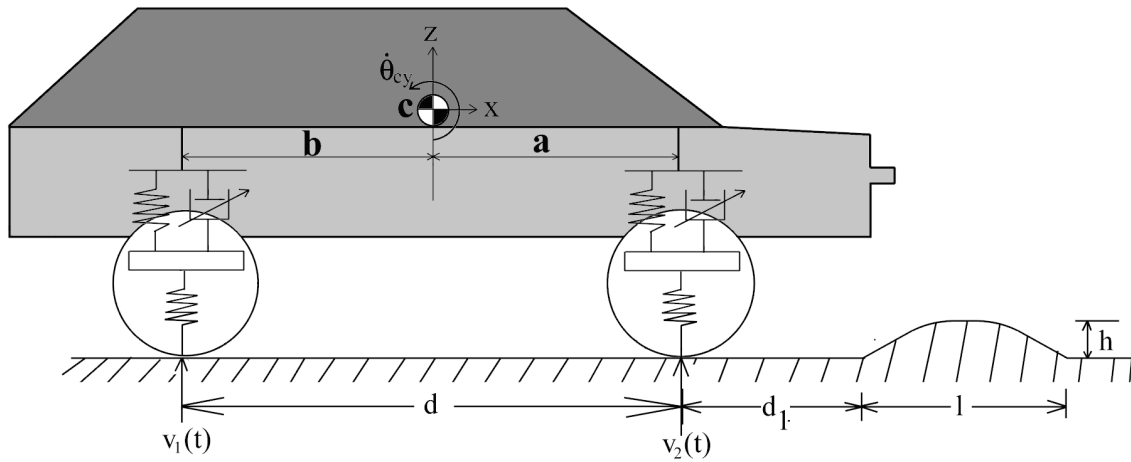

Fig. 4.1 Schema of Planar Vehicle

Similarly, normal and tangential velocity for rear suspension reference point is

$$\left. \begin{aligned} v_{\text{nrr}} &= (\dot{z} - \dot{\theta}_{cy} b) \\ v_{\text{trr}} &= \dot{x} \end{aligned} \right\} \quad (4.2)$$

From Newton Euler Equation, one obtains

$$\left. \begin{aligned} m_c \ddot{x} &= m_c \dot{\theta}_{cy} \dot{z} + \sum F_x \\ m_c \ddot{z} &= -m_c \dot{\theta}_{cy} \dot{x} + \sum F_z \end{aligned} \right\} \quad (4.3)$$

4.2.2 Bond Graph Model

The bond graph model of a vehicle considering only heave and pitch motion is shown in Fig. 4.2. The simple vehicle model considered here does not include the drive, transmission system and tire dynamics, *etc.* The drive is considered later. The vehicle control parameter is the linear speed. The longitudinal speed of the vehicle is an external

system are modelled. The simple vehicle model considered here includes the drive. The drive is electrical. In this model, the motor is attached at the rear wheel of the car to produce the torque for purpose of moving the vehicle. The voltage of motor is denoted by SE element and the transmission ratio is described by TF element. The Pacejka's magic formula is implemented by the forces F_3 and F_4 (SE elements) for rear and front wheels. Longitudinal slip velocity develops longitudinal force F_x whereas side slip velocity and camber angle γ generate side force F_y and self aligning moment M_z . Pacejka's magic formula states that longitudinal force, side force and the self-aligning moment are functions of longitudinal slip and side slip, respectively. It is given as

$$y_o = D \sin \left[C \tan^{-1} \left\{ Bx_i - E \left(Bx_i - \tan^{-1} (Bx_i) \right) \right\} \right] \quad (4.4)$$

Ply-steer, rolling resistance, conicity effects may cause slight variation in the function in Eq. (4.4), but these variations are may be neglected. The constant parameters can be determined by measuring the tyre forces and moments by sophisticated equipments.

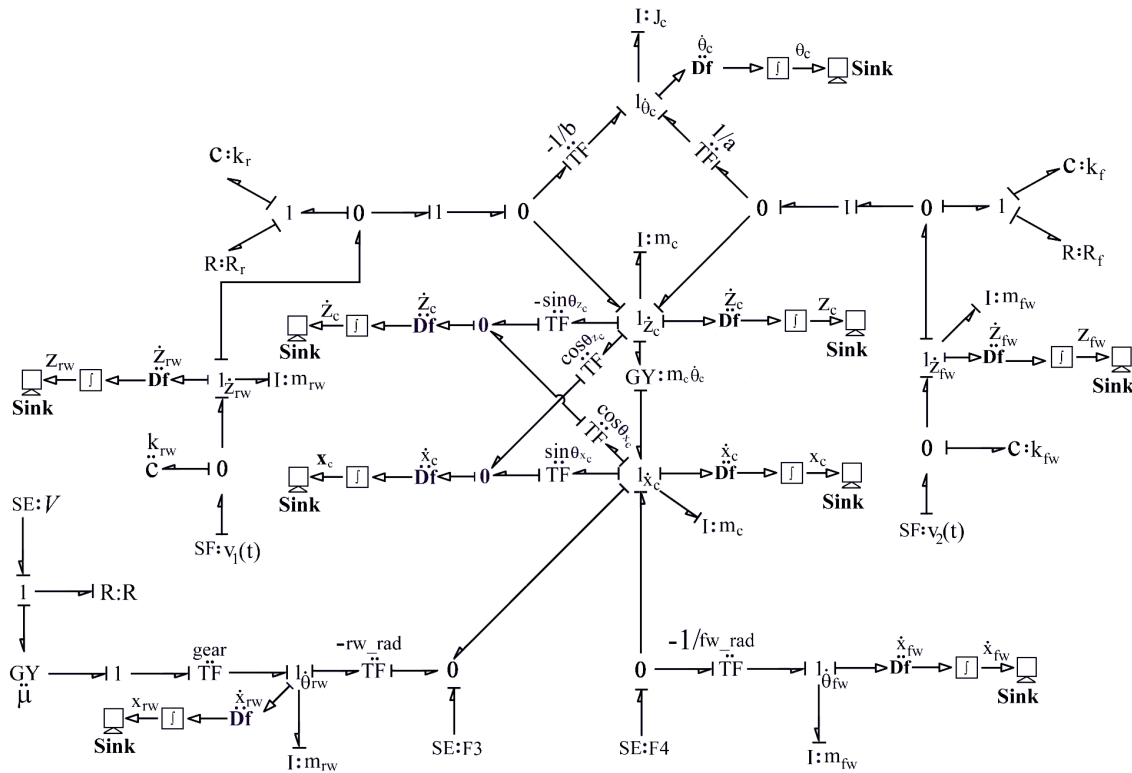

Fig. 4.3 Bond Graph Model of Planar Vehicle with Passive Suspension System

k_{fw} and k_{rw} connected to 0 junction, to indicate the stiffness of wheel and k_f and k_r show the stiffness of front and rear spring which is connected to 0 junction. The bump excitation is denoted by the SF element which is calculated by the Equation (4.5- 4.6). Bump excitation of front wheel when the vehicle moves with constant speed of v m/s is

$$\begin{aligned} \dot{Z} &= \pi hv/l \cos(\pi v/l(t - d_1/v)) \text{ when } d_1/v \leq t \leq (d_1 + l)/v \\ &= 0 \text{ when } t > (d_1 + l)/v \end{aligned} \quad (4.5)$$

Bump excitation of rear wheel is

$$\begin{aligned} \dot{Z} &= \pi hv/l \cos(\pi v/l(t - (d_1 + d)/v)) \text{ when } (d_1 + d)/v \leq t \leq (d + d_1 + l)/v \\ &= 0 \text{ when } t > (d + d_1 + l)/v \end{aligned} \quad (4.6)$$

4.3.1 Simulation Result for Passive System

Planar vehicle model are simulated to determine the heave and pitch motion of vehicle using the passive suspension system. Heave and pitch motion of planar vehicle model with passive suspension system is modelled. The parameter values are given in Table 4.1.

Table 4.1: Parameter Values for Planar Vehicle Model with Passive System

Subsystem	Parameter values			
Vehicle body	$a = 1 \text{ m}$	$b = 1 \text{ m}$	$m_{\text{car}} = 200 \text{ kg}$	$J_{\text{car}} = 20 \text{ kg m}^2$
	$k_r = 2 \times 10^5 \text{ N/m}$	$k_f = 2 \times 10^5 \text{ N/m}$	$\zeta = 1.2$	$v_{\text{ref}} = 1 \text{ m/sec}$
Wheel	$m_w = 20 \text{ kg}$	$J_{wf} = 5 \text{ kg m}^2$	$J_{wr} = 5 \text{ kg m}^2$	$k_w = 2 \times 10^7 \text{ N/m}$
	$r_w = 0.3 \text{ m}$			
Motor	$V = 400 \text{ V}$	$R_{\text{motor}} = 0.1 \text{ Ns/m}$	$G = 8$	$\mu_{\text{motor}} = 0.4 \text{ Nm/A}$
Road	$h = 0.1 \text{ m}$	$l = 0.3 \text{ m}$	$d_1 = 5 \text{ m}$	$d = 2 \text{ m}$

Heave and pitch motions are shown in Fig. 4.4. The first simulation of the integrated model architecture was performed for time duration of 15s. In the plot for heave and pitch motion, it is found that the result is satisfactorily acceptable for the heave as well as for the pitch motion (Fig. 4.4).

Table 4.2 shows the parameter used for plot the graph of displacement, velocity, force and acceleration. Figure 4.5 shows the output of the passive suspension system. Here relative displacement, relative velocity, damping force and mass absolute

acceleration are plotted as a function of time for the sinusoidal input. Passive is a steady state response of the system and show the system is a sinusoidal excitation.

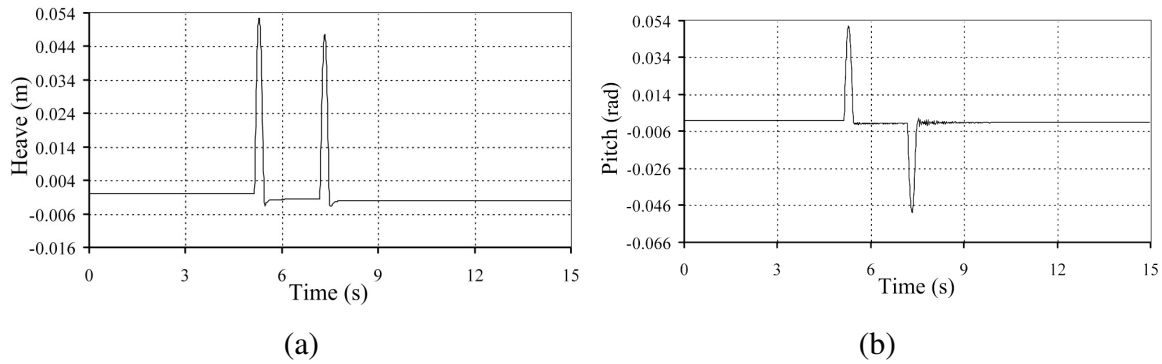

Fig. 4.4 Heave and Pitch Motion of Vehicle Body with Passive Suspension System

Table 4.2: Parameter Values for Outputs of Passive Suspension System

Subsystem	Parameter values			
Vehicle body	$a = 1 \text{ m}$	$b = 1 \text{ m}$	$m_{\text{car}} = 1000 \text{ kg}$	$J_{\text{car}} = 20 \text{ kg m}^2$
	$k_r = 10^5 \text{ N/m}$	$k_f = 10^5 \text{ N/m}$	$\zeta = 0.2$	$\omega = 0 \text{ to } 50 \text{ rad/s}$
Wheel	$k_w = 10^7 \text{ N/m}$	$m_w = 50 \text{ kg}$		

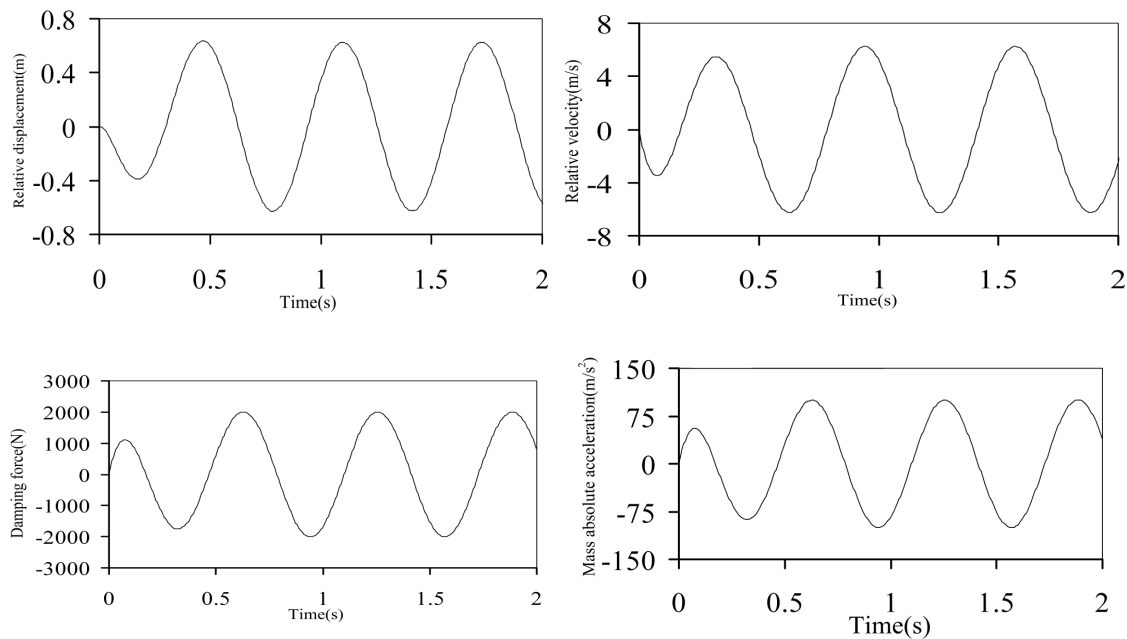

Fig. 4.5 Passive Suspension Outputs

4.4 R-S CONTROL METHOD

Rakheja-Sankar control algorithm is described considering the one degree of freedom (DOF) quarter car model. The 1-DOF car model is shown in Fig. 4.6.

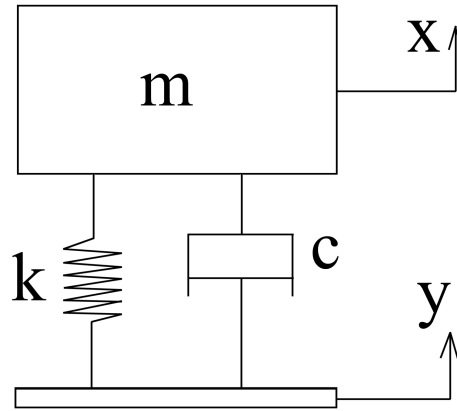

Fig. 4.6 1-DOF Quarter Car Model

The equation of motion single DOF system is given by

$$m\ddot{x} + k(x - y) + c(\dot{x} - \dot{y}) = 0 \quad (4.7)$$

In this system m represents the vehicle mass, k is the stiffness of suspension spring and c represents the damping coefficient of the damper. x is the movement of mass and y represents the road disturbance. The wheel is not considered in this system. The acceleration of the vehicle is given by

$$\ddot{x} = \frac{1}{m}(-F_d - F_k) \quad (4.8)$$

F_d and F_k represent the damping and spring force, respectively. This equation represents that when damping and spring force lie in the same direction, the damping force increases the acceleration of the vehicle body. In semi active damper, when no damper force is required, spring force and damper force act in the same direction but when minimum amount of damping force is required and spring and damping force lie in the opposite direction, the acceleration transmissibility is minimum.

To know the damping force, a control strategy developed by Rakheja-Sankar is known as R-S control strategy. This control strategy is defined as

$$F_d = \left. \begin{array}{l} F_{\max} \quad \forall (x - y)(\dot{x} - \dot{y}) \leq 0 \\ F_{\min} \quad \forall (x - y)(\dot{x} - \dot{y}) > 0 \end{array} \right\} \quad (4.9)$$

$$F_{\min} = \beta F_{\max} \quad (4.10)$$

Equation (4.9) is the R-S control law which is used in semi active suspension system to improve the stability of vehicle body and decrease the transmissibility of vehicle. β is a constant value.

4.5 VEHICLE WITH SEMI ACTIVE SUSPENSION SYSTEM

The semi active suspension systems are attached in the front and rear wheel of the bicycle vehicle body. Support parameters that are used in semi active suspension system are estimated by using the bond graph and their response to road excitation is studied. Heave and pitch motion of planar vehicle model are estimated using the semi active system. The bond graph of planar vehicle model with semi active suspension system is shown in Fig. 4.7.

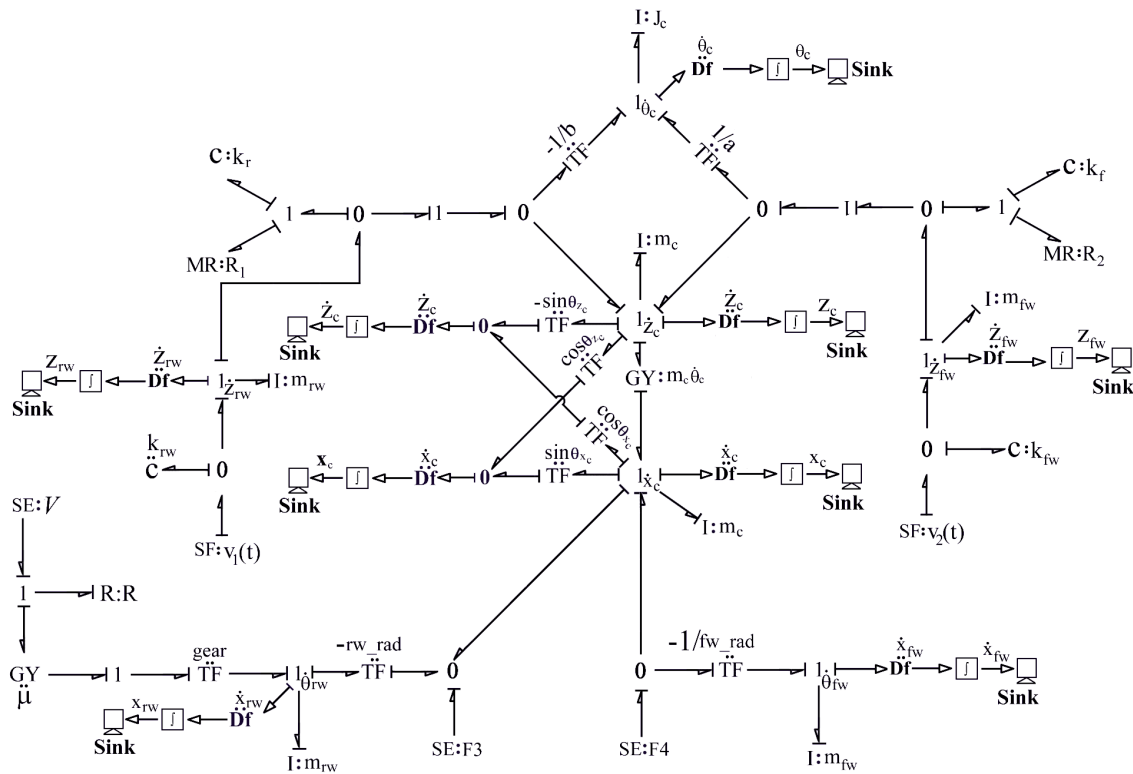

Fig. 4.7 Bond Graph Model with Semi Active Suspension System

From the Newton-Euler equations, it is known that $m_c \dot{\theta}_{cy} \dot{z}$ and $-m_c \dot{\theta}_{cy} \dot{x}$ are the pseudo forces which can be implemented by the gyrator (GY) element in bond graph.

The line with half arrow shows the power bond and full arrow shows the information bond. The $I: m_c$ are the inertia of car in the moving frame and these can be converted into the inertial frame by the pseudo forces. $I: J_c$ is polar moment of inertia. Equation (4.1) & (4.2) are used to calculate the normal and tangential velocities of wheel using the transformer (TF) elements. The flow detector (Df) connected to the inertial frame is used to know the velocity and displacement of vehicle moving in the x and z direction.

In this model, voltage of motor is denoted by SE element and motor is attached at the rear wheel of the car for the purpose of moving the vehicle. The Pacejka's magic formula are implemented by the forces F3 and F4 (SE elements) for the rear and front wheel.

The velocities $V_1(t)$ and $V_2(t)$ are represented by SF elements connected to 0 junction which are used for ground excitation of front and rear wheel of planar vehicle model. The R_1 and R_2 are the damping coefficient of modulated damping elements (MR) and this damping force can be controlled by Rakheja-Sankar (R-S) control strategy. The modulated dampers are modulated by the linear velocity and displacement of the wheel.

4.6 PERFORMANCE ANALYSIS

Table 4.2 shows the parameters which are used in the simulation of vehicle bicycle model. Implementation of semi active suspension system on the bicycle model and testing the control strategy can be done in this methodology.

Table 4.3: Parameter Values Used in Simulation of Planar Vehicle Model

Subsystem	Parameter values			
Vehicle body	$a = 1 \text{ m}$	$b = 1 \text{ m}$	$m_{\text{car}} = 200 \text{ kg}$	$J_{\text{car}} = 20 \text{ kg m}^2$
	$k_r = 2 \times 10^5 \text{ N/m}$	$k_f = 2 \times 10^5 \text{ N/m}$	$\zeta = 1.2$	$v_{\text{ref}} = 1 \text{ m/sec}$
Wheel	$m_w = 20 \text{ kg}$	$J_{\text{wf}} = 5 \text{ kg m}^2$	$J_{\text{wr}} = 5 \text{ kg m}^2$	$k_w = 2 \times 10^7 \text{ N/m}$
	$r_w = 0.3 \text{ m}$	$\beta_f = 0.002$	$\beta_r = 0.002$	
Motor	$V = 400 \text{ V}$	$R_{\text{motor}} = 0.1 \text{ Ns/m}$	$G = 8$	$\mu_{\text{motor}} = 0.4 \text{ Nm/A}$
Road	$h = 0.1 \text{ m}$	$l = 0.3 \text{ m}$	$d_1 = 5 \text{ m}$	$d = 2 \text{ m}$

All simulation process is performed in SYMBOLS Shakti software [65]. In bond graph model, the equation of motion of physical system is derived by the SYNBOLS software.

The simulation of bicycle vehicle model with semi active suspension system and passive suspension, while moving with velocity 1 m/s and their responses of bump excitation to front and rear wheel are shown in Fig. 4.8. Heave motion of the centroid of the vehicle body as a function of time is shown in Fig. 4.8, to show the comparison between the semi active and passive system of vehicle bicycle body. The result shows that heave motion of semi active system is smaller than that of passive system. So Semi active system is better than that of passive system. Pitch motion and velocity as a function of time using the semi active suspension system in planar vehicle model are shown in Fig. 4.9 and Fig. 4.10, respectively.

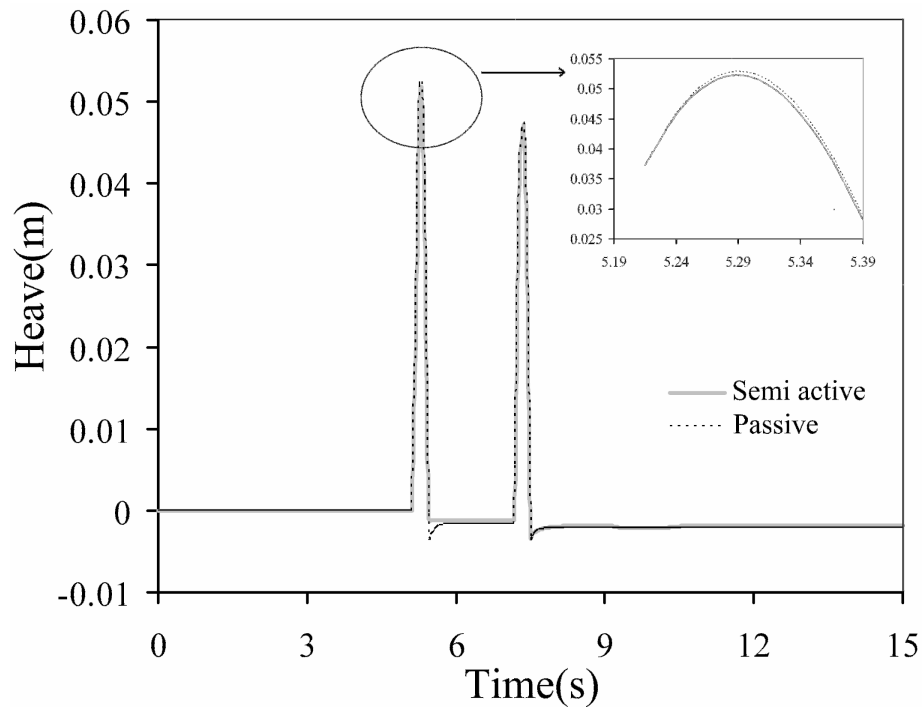

Fig 4.8 Heave Motion of Vehicle (Passive and Semi Active) with Bump Excitation

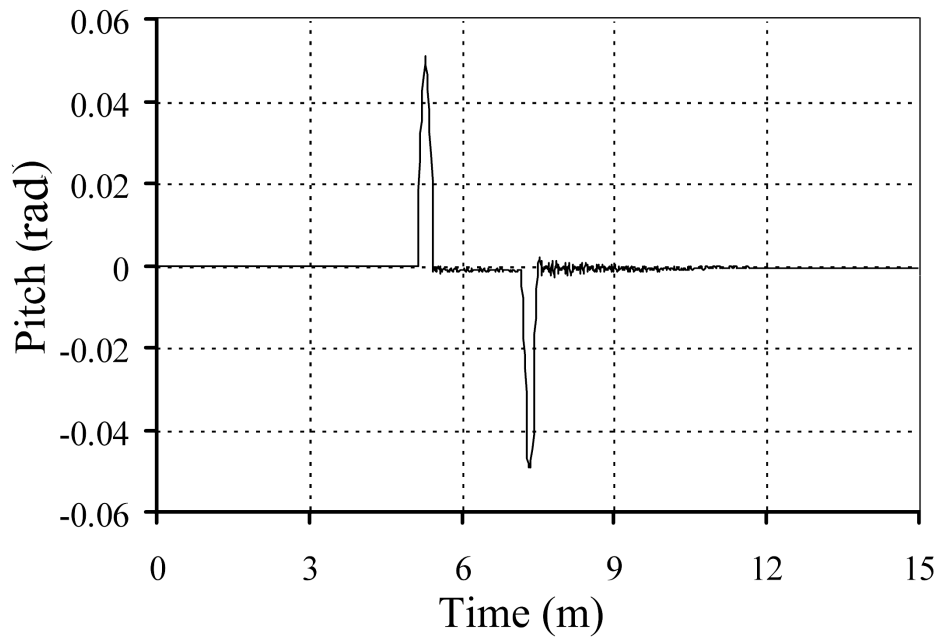

Fig. 4.9 Pitch Motion of Vehicle with Semi Active System

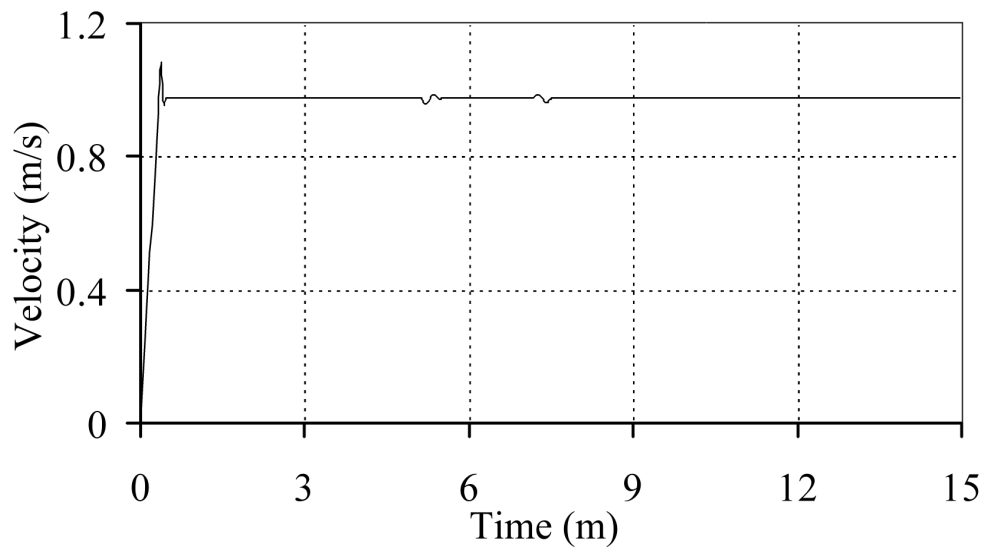

Fig. 4.10 Vehicle's Velocity with Semi Active System

The semi active suspension system shows the non linearity effect of the system. Due to the non linearity effect of the system, these systems are not sinusoidal because the system has discontinuous mass, acceleration as well as damping force. Fig. 4.11 shows the output of the semi active suspension system. Here relative displacement, relative

velocity, damping force and absolute acceleration is plotted as a function time. Table 4.4 shows the values that are used for the outputs of semi active suspension system.

Table 4.4: Parameter Values for Outputs of Semi Active Suspension System

Subsystem	Parameter values			
Vehicle body	$a = 1 \text{ m}$	$b = 1 \text{ m}$	$m_{\text{car}} = 1000 \text{ kg}$	$J_{\text{car}} = 20 \text{ kg m}^2$
	$k_r = 10^5 \text{ N/m}$	$k_f = 10^5 \text{ N/m}$	$\zeta = 0.2$	$\omega = 15 \text{ rad/s}$
Wheel	$m_w = 50 \text{ kg}$	$k_w = 10^6 \text{ N/m}$	$\beta_f = 0.5$	$\beta_r = 0.5$

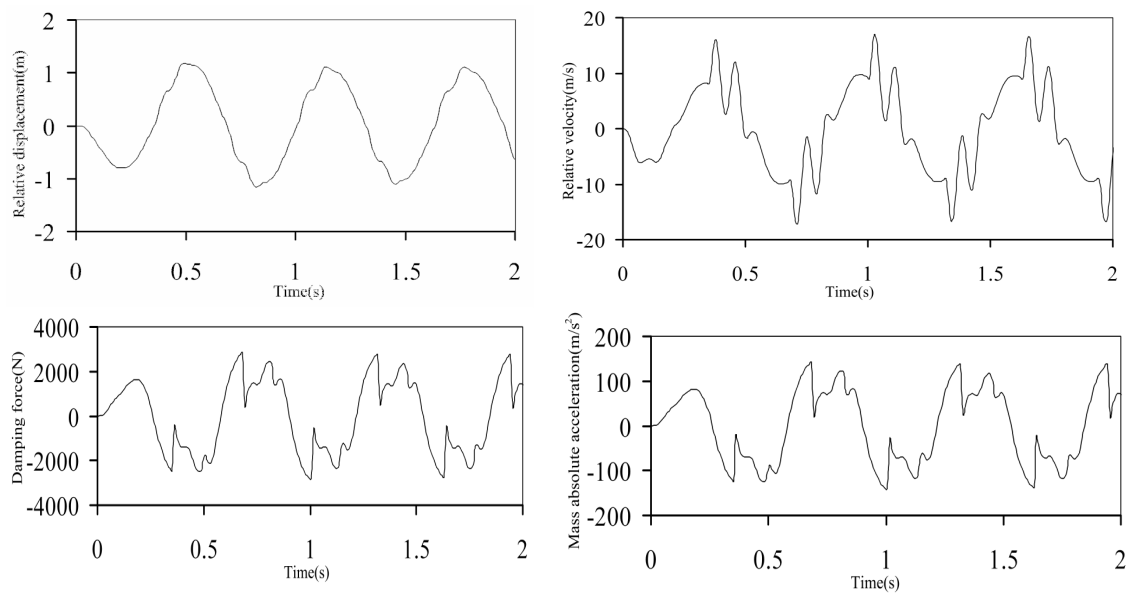

Fig. 4.11 Semi Active Suspension System Outputs

4.7 SOLENOID VALVE SEMI ACTIVE DAMPER

4.7.1 Modelling of Solenoid Valve

Figure 4.12 shows the solenoid valve which is used to development of semi active damper in the planar vehicle model. It consists of reservoir chamber, compression chamber, foot valve, piston valve, gas chamber and piston. The main concept of solenoid valve is to find the damping velocity and solenoid valve current for the damper force and their performance could be analyzed with different parameters and parts [66].

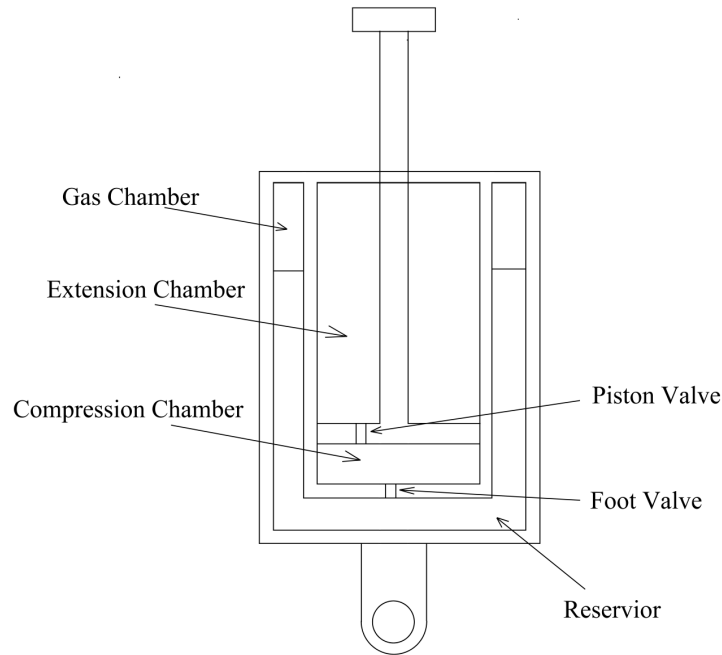

Fig. 4.12 Semi Active Solenoid Valve

When external force is applied, piston moves downwards and fluid flows from the compression chamber into the extension chamber through the piston valve. When piston moves downward then pressure is created and fluid flows from compression chamber to the reservoir chamber through foot valve also. This fluid flow pressurizes the gas especially nitrogen inside the gas chamber. The pressure of gas is equal to the pressure of fluid in the reservoir.

4.7.2 Bond Graph Model of Solenoid Valve

The bond graph model of semi active solenoid valve as shown in Fig. 4.13, that system represents the hydraulic system. P_C And P_E are the pressure of compression and extension chamber represented at 0 junctions. The bulk modulus of compression and extension chamber is represented by C elements *i.e.*, k_e and k_c . The solenoid piston mass m_p is indicated at the 1 junction. To know the movement of piston and piston valve, the flow detector (DF) is connected in the moving frame *i.e.*, piston valve and piston.

$$Q_1 = A_v C_d \sqrt{\frac{2|P_E - P_C|}{\rho}} \quad (4.14)$$

$$Q_2 = A_1 C_d \sqrt{\frac{2|P_E - P_C|}{\rho}}, \quad A_1 = \pi R_{eqv}^2 \quad (4.15)$$

Where A_v is the area of valve. R_{eqv} be the equivalent radius of orifice, C_d is discharge of coefficient.

Spring force is modelled by the SE element at the 1 junction. It is linear force can be calculated as follows:

$$F_{spring} = k_v v \quad (4.16)$$

k_v is the stiffness of valve spring and v be the movement of spring. At compression chamber pressure, the pressure of gas is equal to te pressure of fluid flows in the reservoir. The fluid flows from the compression chamber into the reservoir chamber through the foot valve. In bond graph, the pressure of gas is modelled as SE elements indicate at 1 junction. The flow rate of foot valve can be obtained by the following equation:

$$Q_{FV} = C_{FV} (P_C - P_{gas}) \quad (4.17)$$

C_{FV} be the foot valve discharge coefficient and pressure of gas can be calculated by the following equation:

$$P_{gas} = P_{0gas} \left(\frac{V_{0gas}}{V_{0gas} - x(\pi R_r^2)} \right)^{1.4} \quad (4.18)$$

P_{0gas} is initial gas chamber pressure and V_{0gas} be the initial gas volume and x is the movement of piston and R_r denotes the radius of the piston rod.

4.7.3 Simulation Results

To develop bicycle vehicle model with semi active solenoid valve, the capsule (sub program) of bond graph model of solenoid valve is attached with the bicycle vehicle model along with motor. The capsule of solenoid valve is replaced with the semi active suspension system as shown in Fig. 4.14. Table 4.5 shows the various parameter values those are used for the simulation of bicycle vehicle model with solenoid valve.

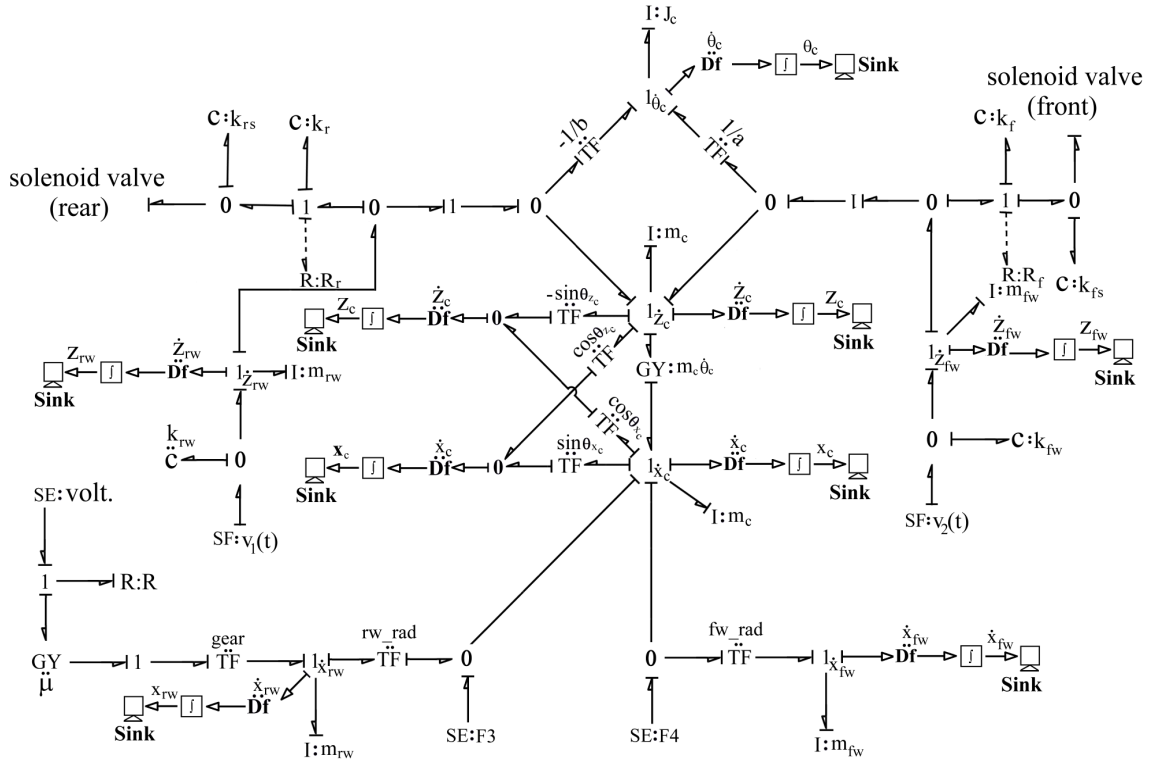

Fig. 4.14 Bond Graph of Planar Vehicle Model with Solenoid Valve

Table 4.5: Parameter Values of Vehicle Model with Solenoid Valve

Subsystem	Parameter values			
Vehicle body	$a = 1 \text{ m}$	$b = 1 \text{ m}$	$m_{\text{car}} = 200 \text{ kg}$	$J_{\text{car}} = 20 \text{ kg m}^2$
	$k_r = 2 \times 10^5 \text{ N/m}$	$k_f = 2 \times 10^5 \text{ N/m}$	$v_{\text{ref}} = 1 \text{ m/sec}$	
Wheel	$m_w = 20 \text{ kg}$	$J_{\text{wf}} = 5 \text{ kg m}^2$	$J_{\text{wr}} = 5 \text{ kg m}^2$	$k_w = 2 \times 10^7 \text{ N/m}$
	$r_w = 0.3 \text{ m}$			
Motor	$V = 400 \text{ V}$	$R_{\text{motor}} = 0.1 \text{ Ns/m}$	$G = 8$	$\mu_{\text{motor}} = 0.1 \text{ Nm/A}$
Road	$h = 0.1 \text{ m}$	$l = 0.3 \text{ m}$	$d_1 = 10 \text{ m}$	$d = 2 \text{ m}$
Solenoid valve	$A_v = 0.1 \text{ m}^2$	$L_s = 0.5 \text{ m}$	$R_r = 0.0127$	$R_p = 0.0317$
	$V_{\text{fluid}} = 1 \text{ m/s}$	$\theta = 1.20427 \text{ rad}$	$C_d = 0.6$	$R_{\text{equ}} = 0.0001$
	$F_1 = 10 \text{ N}$	$m_p = 1 \text{ kg}$	$P_E = 100 \text{ Pa}$	$P_C = 1000 \text{ Pa}$
	$C_{fv} = 0.001$	$P_{0\text{gas}} = 1.379 \times 10^6$	$V_{0\text{gas}} = 0.0019$	$\beta'_r = 2000 \text{ Pa}$
	$\beta'_f = 2000 \text{ Pa}$	$k_v = 20 \text{ N/m}$	$k_s = 10^6 \text{ N/m}$	$\rho = 875 \text{ kg/m}^3$

Heave and pitch motion as a function of time is shown in Fig. 4.15 and Fig. 4.16. Result shows that semi active solenoid valve has a better vibration isolation and road

handling. Use of solenoid valve in planar vehicle model is better comfort for passenger than the passive suspension system in the vehicle.

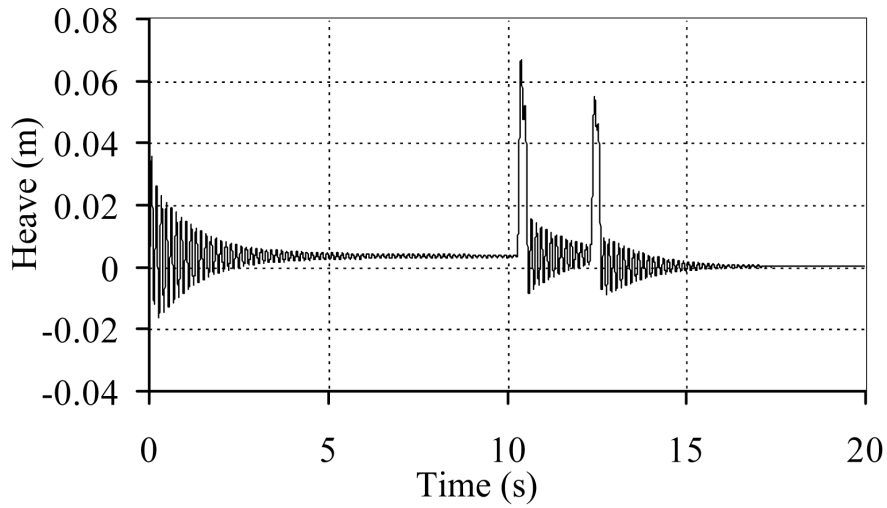

Fig. 4.15 Heave Motion of Planar vehicle with solenoid Valve Model

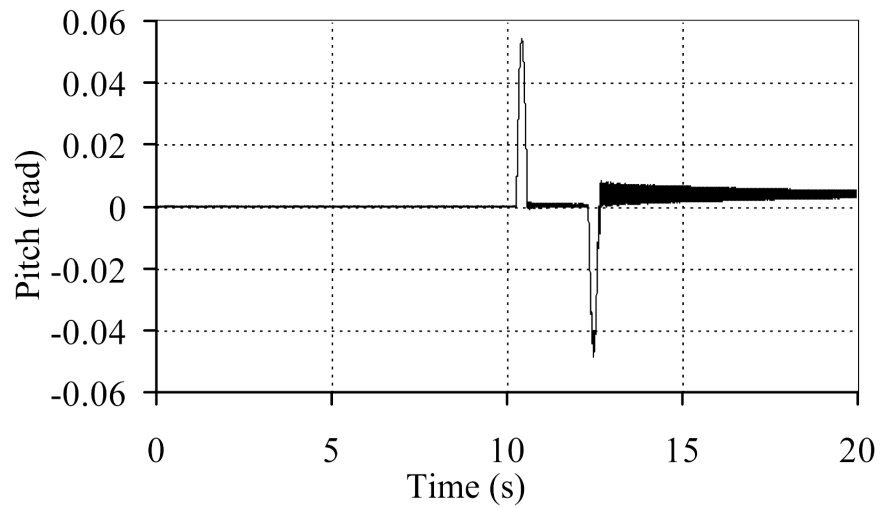

Fig. 4.16 Pitch Motion of Vehicle Body with Semi Active Solenoid Valve

The overall performance of planar vehicle model is that semi active solenoid damper has better and great performance than that of passive suspension system. It improves the vehicle handling and ride comfort for passenger.

5.1 CONCLUSION

The main objective of this thesis was to develop the semi active solenoid valve suspension model. Using bond graph, this suspension system was modelled with variable damping coefficient for a bicycle vehicle model to improve the comfort of vehicle. Appropriate control law *i.e.*, R-S control strategy was used in semi active suspension for the simulation of bicycle vehicle model. By using this control law, vehicle should be improved due to vibration isolation, vehicle stability and handling, ride comfort for passengers. This system shows the non linearity characteristics. Semi active suspension system is better than passive suspension system.

Bond graph modelling of multi body system and bond graph modelling of vehicle are considered in Chapter 2. Bond graph modelling of semi active suspension system with appropriate control law is considered in the literature survey. The bond graph implementation in passive, semi active, skyhook system and semi active solenoid valve and details review about the bond graph and their sub system are considered in Chapter 3. Transmissibility and output of skyhook, semi active and passive is studied with bond graph model of each system. For improvement of vehicle body, the development and control of semi active suspension system and semi active solenoid valve with control law are described in Chapter 4. Heave and pitch motion of vehicle body is considered for showing the better performance of vehicle.

5.2 SCOPE OF FUTURE WORK

Based on this thesis, the following area of work are suggested for further exploration

- R-S control strategy and semi active solenoid valve may be used in four wheel vehicle body to give the better performance of vehicle body as the load transfer during maneuvering in a curved path is not possible for the bicycle vehicle model.
- MR fluid damper along with this control strategy may used to perform the heave and pitch motion of the bicycle vehicle model and four- wheel vehicle body.

REFERENCES

- [1] Margolis, D. L., and Shim, T. A bond graph model incorporating sensors, actuators, and vehicle dynamics for developing controllers for vehicle safety. *Journal of the Franklin Institute*, 2001, **338**, 21–34.
- [2] Dauphin-Tanguy, G., Rahmani, A., and Sueur, C. Bond graph aided design of controlled systems. *Simulation Practice and Theory*, 1999, **7** (5–6), 493–513.
- [3] Gawthrop, P. J. Physical model-based control: A bond graph approach. *Journal of the Franklin Institute*, 1995, **332** (3), 285–305.
- [4] Samantaray, A. K., and Ould Bouamama, B. *Model-based Process Supervision*, 2008 (Springer Verlag, London).
- [5] Gawthrop, P. J. Bond graphs: A representation for mechatronic systems. *Mechatronics*, 1991, **1** (2), 127–156.
- [6] Granda, J. J. The role of bond graph modelling and simulation in mechatronics systems: An integrated software tool: CAMP-G, MATLAB–SIMULINK. *Mechatronics*, 2002, **12** (9–10), 1271–1295.
- [7] Gawthrop, P. J, Neild, S. A., Gonzalez-Buelga, A., and Wagg, D. J. Causality in real-time dynamic substructure testing. *Mechatronics*, 2009a, **19** (7), 1105–1115.
- [8] Lin, C. F., Tseng, C.Y., and Tseng, T. W. A hardware-in-the-loop dynamics simulator for motorcycle rapid controller prototyping. *Control Engineering Practice*, 2006, **14** (12), 1467–1476.
- [9] Bruns, F. W., and Erbe, H. H. Mixed reality with hyper-bonds—A means for remote labs. *Control Engineering Practice*, 2007, **15** (11), 1435–1444.
- [10] Cho, W. A Bond Graph Approach to the Modelling of General Multibody Dynamics Systems. *KEME International Journal*, 1998, **12** (5), 888–898.
- [11] Marquis-favre, W. and Scavarda, S. Bond Graph representation of Multibody Systems with Kinematic Loops. *Journal of the Franklin Institute*, 1998, **335B** (4), 643–660.
- [12] Gawthrop, P. J., and Ronco, E. Estimation and control of mechatronic systems using sensitivity bond graphs. *Control Engineering Practice*, 2000b, **8** (11), 1237–1248.

- [13] Merzouki, R., Ould-Bouamama, B., Djeziri, M. A., and Bouteldja, M. Modelling and estimation of tire–road longitudinal impact efforts using bond graph approach. *Mechatronics*, 2007a, **17** (2–3), 93–108.
- [14] Gawthrop, P. J., Jones, R. W., and Mackenzie, S. A. Identification of partially-known systems. *Automatica*, 1992, **28** (4), 831–836.
- [15] Merzouki, R., Medjaher, K., Djeziri, M. A., and Ould-Bouamama, B. Backlash fault detection in mechatronic system. *Mechatronics*, 2007b, **17** (6), 299–310.
- [16] Ould Bouamama, B., Medjaher, K., Samantaray, A. K., and Staroswiecki, M. Supervision of an industrial steam generator. Part I: Bond graph modelling. *Control Engineering Practice*, 2006, **14** (1), 71–83.
- [17] Ould Bouamama, B., Medjaher, K., Bayart, M., Samantaray, A. K., and Conrard, B. Fault detection and isolation of smart actuators using bond graphs and external models. *Control Engineering Practice*, 2005, **13** (2), 159–175.
- [18] Karnopp, D. C., Margolis, D. L., and Rosenberg, R. C. *System Dynamics, Modelling and Simulation of Mechatronic Systems*, 2000 (John Wiley & Sons, NY).
- [19] Borutzky, W. *Bond Graphs-A Methodology for Modelling Multidisciplinary Dynamic Systems*, 2004 (SCS Publishing House, Erlangen, San Diego).
- [20] Mukherjee, A., Karmakar, R., and Samantaray, A. K. *Bond Graph in Modelling, Simulation and fault Identification*, 2006 (CRC Press, FL).
- [21] Samantaray, A. K., and Ould Bouamama, B. *Model-based Process Supervision*, 2008 (Springer Verlag, London).
- [22] Bos, A. M. *Modelling Multibody Systems in terms of Multibond Graphs, with application to a motorcycle*, PhD thesis at Twente University, 1986.
- [23] Gawthrop, P. J. Physical model-based control: A bond graph approach. *Journal of the Franklin Institute*, 1995, **332** (3), 285–305.
- [24] Dauphin-Tanguy, G., Rahmani, A., and Sueur, C. Bond graph aided design of controlled systems. *Simulation Practice and Theory*, 1999, **7** (5–6), 493–513.
- [25] Pathak, P. M., Kumar, R. P., Mukherjee, A., and Dasgupta, A. A scheme for robust trajectory control of space robots. *Simulation Modelling Practice and Theory*, 2008, **16** (9), 1337–1349.

- [26] Ngwompo, R. F., and Gawthrop, P. J. Bond graph-based simulation of non-linear inverse systems using physical performance specifications. *Journal of the Franklin Institute*, 1999, **336** (8), 1225–1247.
- [27] Hrovat, D., Asgari, J., and Fodor, M. *Automotive Mechatronic Systems, In: Mechatronic Systems Techniques and Applications*. 2000 (Gordon and Breach Science Publishers, Amsterdam), 1–98.
- [28] Filippini, G., Nigro, N., and Junco, S. Vehicle dynamics simulation using bond graphs. *International conference on integrated modelling and analysis in applied control and automation (IMAACA 2007)*, Buenos Aires, Argentina.
- [29] Margolis, D. L., and Shim, T. A bond graph model incorporating sensors, actuators, and vehicle dynamics for developing controllers for vehicle safety. *Journal of the Franklin Institute*, 2001, 338, 21–34.
- [30] Pacejka, H. B. Modelling Complex Vehicle Systems Using Bond Graphs. *Journal of the Franklin Institute*, 1985, **319** (1/2), 67–81.
- [31] Louca, L. S., Stein, J. L., and Rideout, D. G. Generating Proper Integrated Dynamic Models for Vehicle Mobility Using a Bond Graph Formulation. *Proceedings of the 2001 International conference on Bond Graph Modelling (ICBGM'01)*, Phoenix, AZ, 2001, **33** (1), 339–345.
- [32] Pacejka, H. B. *Tyre and Vehicle Dynamics*, 2002 (Butterworth Heinemann, Oxford).
- [33] Shiao, Y., Lai, C. C., and Nguyen, Q. A. The Analysis of a Semi-Active Suspension System. *SICE Annual Conference 2010*, The Grand Hotel, Taipei, Taiwan.
- [34] Collete, C., and Preumont, A. High frequency energy transfer in semi-active suspension. *Journal of Sound and Vibration*, 2010, **329**, 4604–4616.
- [35] Mailat, f., and donescu, S., AND Chiroiu, V. On The Automotive Semi-Active Suspensions *Proceedings Of The Romanian Academy, Series A*, Volume 5, Number 1/2004.
- [36] Leluzzi, M., Turco, P., and Montiglio, M. Development of a heavy truck semi-active suspension control. *Control Engineering Practice*, 2006, **14**, 305–312.

- [37] Vassal, C. P., Savaresi, S. M., Spelta, C., Sename, O., and Dugard, L. A Methodology for Optimal Semi-Active Suspension Systems Performance Evaluation *49th IEEE Conference on Decision and Control (CDC 2010), Atlanta, Georgie : United States*, 2010.
- [38] Fang, Z., Shu, W., Du, D., Xiang, B., He, Q., and He, K. Semi-active Suspension of a Full-vehicle Model based on Double-loop Control. *Procedia Engineering*, 2011, **16**, 428 – 437.
- [39] Vassal, C. P., Sename, O., Dugard, L., Gaspar, P., Szabo, Z., and Bokor, J. A new semi-active suspension control strategy through LPV technique. *Control Engineering Practice*, 2008, **16**, 1519– 1534.
- [40] Eslaminasab, N., Vahid A, O., and Golnaraghi, F. Non linear analysis of switched semi active controlled systems. *Vehicle System Dynamics* ,2011, **49**, 291–309.
- [41] Ahmadian, M., and Blanchard, E. Non dimensionalised closed form parametric analysis of semi active vehicle system using a quarter car model. *Vehicle System Dynamics*, 2011, **49**, 219–235.
- [42] Chen, B., Shiu, Y., and Hsieh, F. Sliding-mode control for semi-active suspension with actuator dynamics. *Vehicle System Dynamics*, 2011, **49**, 277–290.
- [43] Maciejewski, I., and Krzyzynski, T. control design of semi-active seat suspension systems *Theoretical And Applied Mechanics*, 2011, **49**, 1151–1168.
- [44] Yi, K., and Hedrick, J. K. Active and Semi-Active Heavy Truck Suspensions to Reduce Pavement Damage. *University of California and transportation centre, SAE technical Paper series*, 1989.
- [45] Kamalakannan, K., ElayaPerumal, A., Mangalaramanan, S.,and Arunachalam, K. Performance Analysis and Behaviour Characteristics of CVD (Semi Active) in Quarter Car Model. *Jorden Journal of Mechanical and Industrial Engineering*, 2011, **5**, 261–265
- [46] Spelta, C., Savaresi, S., and Fabbri, L. Experimental analysis of a motorcycle semi-active rear suspension. *Control Engineering Practice*, 2010, **18**, 1239–1250.
- [47] Margolis, D.L. Semi-Active Heave and Pitch Control for Ground Vehicles. *Vehicle System Dynamics*, 1982,**11**, 31–42.

- [48] Margolis, D.L. Semi-Active Control of Wheel Hop in Ground Vehicles *Vehicle System Dynamics*, 1983, **12**, 317–330.
- [49] Hassan, S. A. Thesis on fundamentals studies of passive, active and semi active automotive suspension system. 1986
- [50] Witter, M., Swevers, J. Black-box model identification for a continuously variable, electro-hydraulic semi-active damper. *Mechanical Systems and Signal Processing*, 2010, **24**, 4–18.
- [51] Vassal, C. P., Spelta, C., Sename, O., Savaresi, S.M and Dugrad, L. Survey and performance evaluation on some automotive semi-active suspension control methods: A comparative study on a single-corner model. *Annual Reviews in Control*, 2012, **36**, 148–160.
- [52] Song, X. Cost-Effective Skyhook Control for Semiactive Vehicle Suspension Applications *The Open Mechanical Engineering Journal*, 2009, **13**, 17–25.
- [53] Rashid, M.M., Hussain, M. A., Rahim, N. A., and Momoh, J.S. Development of a semi active car suspension control system using magneto- rheological damper model. *International Journal of Mechanical and Materials Engineering (IJMME)*, 2007, **2**, 93–108.
- [54] Ping, H., Wang, Y., Zhang, Y., Liu, Y., and Xu, Y. Integrated control of semi-active suspension and vehicle dynamics control system. *International Conference on Computer Application and System Modelling (ICCASM)*, 2010.
- [55] Georgiou, G., Verros, G. and Natsiavas, S. Multi-objective optimization of quarter-car models with a passive or semi-active suspension system. *Vehicle System Dynamics*, 2007, **45** (1), 77–92.
- [56] Volasek, M., Novak, M., Sika, Z. And Vaculin, O. Extended Ground-Hook - New Concept of Semi-Active Control of Truck's suspension. *Vehicle System Dynamics*, 1997, **27**, 289–303.
- [57] Vanderaa, M. A. H., Muijdarman, J. H. E. A., and Veldpaus, F. E. Constrained Optimal Control of Semi-Active Suspension Systems with Preview. *Vehicle System Dynamics*, 1997, **28**, 307–323.

- [58] Mori, T., Nilkhamhang, I. and Sano, A. Adaptive semi active control of suspension system with MR damper. System Design Engineering, keio university yokohama, japan, 223–8522.
- [59] Lauwerys, C. Ph.D thesis on Control of active and semi-active suspension systems for passenge cars. Katholieke Universiteit Leuven, Belgium, 2005.
- [60] Rao, T. R. M., Rao, G. v., Rao, K.S. and purushottam, A. Analysis of passive and semi active controlled suspension systems for ride comfort in an omnibus passing over a speed bump. *IJRRAS*, 2010, **5** (1).
- [61] Kyongsu, Y. and Song, B.S. Observer Design for Semi-Active Suspension Control. *Vehicle System Dynamics*, 1999, **32**, 129–148.
- [62] Bera, T. K. Ph.D thesis on bond graph aided trajectory tracking and impedance control of parallel manipulators. IIT Kharagpur, 2011.
- [63] Mukherjee, A, Karmakar, R and Samantaray, A. K. *Bond graph in modelling, simulation and fault identification*. Boca Raton, FL: CRC Press, 2006.
- [64] Bera, T.K., Bhattacharya,K. and Samantaray, A.K. Evaluation of antilock braking system with an integrated model of full vehicle system dynamics. *Simulation Modelling Practice and Theory*, 2011, **19**, 2131–2150.
- [65] Smbols User’s Manual, High Tech Consultants. <http://www.htcinfo.com>
- [66] Eslaminasab, N. Ph. D thesis on Development of a Semi-active Intelligent Suspension System for Heavy Vehicles. Waterloo, Ontario, Canada, 2008.

CURRICULUM VITAE

Jagjit singh did his graduation from Sant Baba Bhag Singh Institute of Engineering & Technology in Bachelor of Mechanical Engineering (B. Tech), in the year 2010. After that he has worked as Lecturer in Guru Nanak Institute of Technology Polytechnic college, District-Hoshiarpur, Punjab in the year 2010–2011. In the year 2011, he joined in the Master of Engineering (Production & Industrial Engineering) Programme at Thapar University, Patiala, Punjab. His ME thesis work is in the area of Dynamic Analysis and Control of Semi Active Suspension System for a Heavy Vehicle: A Bond Graph Approach. One paper was published from his research work.

Proceeding of International Conference

- Bera, T. K. and Singh, J. “Analysis and Control of Semi Active Suspension System for a Bicycle vehicle model: A Bond Graph Approach”. Second International Conference on Intelligent Robotics, Automation and Manufacturing (IRAM), IIT Indore, 2013 (under review).