

# **DESIGN OF FRACTAL ANTENNA FOR WLAN AND UWB APPLICATIONS**

*A Thesis submitted in partial fulfilment of the requirements for the award of Degree  
of*

**Master of Engineering  
in  
Electronics and Communication Engineering**

Submitted by  
**Deepti Singh**  
**Roll No. 801361007**

Under guidance of  
**Mr. Sukhwinder kumar**  
**Lecturer**



**Electronics and Communication Engineering Department  
THAPAR UNIVERSITY**

(Established under the section 3 of UGC Act, 1956)

**PATIALA-147004 (PUNJAB)**

**July, 2015**

## DECLARATION

I hereby declare that the dissertation entitled "Design of fractal antenna for WLAN and UWB applications" is an authentic record of my study carried out as partial requirement for the award of degree of M.E. (ECE) at Thapar University, Patiala, under the supervision of Mr. Sukhwinder Kumar, Lecturer, ECED and refers other researcher's work which are duly listed in the reference section.

The matter embodied in this thesis has not been submitted for award of any other degree at this or any other university.

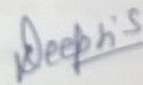

Deepti Singh

Roll No.: 801361007

It is certified that the above statement made by the student is correct to the best of my knowledge and belief.

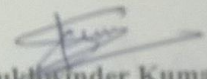

Mr. Sukhwinder Kumar

Lecturer, ECED

Thapar University, Patiala

Countersigned by:

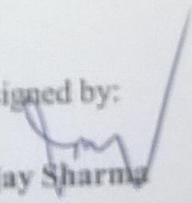

Dr. Sanjay Sharma  
Professor and Head (ECED)  
Thapar University, Patiala

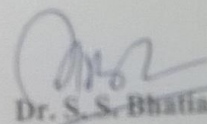

Dr. S. S. Bhatia  
Dean, Academic Affairs  
Thapar University, Patiala

## ACKNOWLEDGEMENT

---

I would like to express my gratitude to my guide Mr.Sukhwinder Kumar, Lecturer, Electronics and Communication Engineering Department, Thapar University, Patiala for his patient guidance and support throughout my work. I am truly very fortunate to have the opportunity to work with him. I found his guidance to be extremely valuable. His depth of knowledge really surpass all imaginable barriers and still he is kind hearted and modest.

I am also thankful to Dr. Sanjay Sharma, Head of the Department, Dr. Amit Kumar Kohli, P.G. coordinator, Electronics and Communication Engineering Department, entire faculty and staff of Electronics and Communication Engineering Department. I would also like to thank my friends who devoted their valuable time and helped me in all possible ways towards successful completion of this work. I thank all those who have contributed directly or indirectly to this work.

At last, I would like to thank my parents and siblings for their unconditional support and encouragement.

Deepti Singh  
Registration No.: 801361007

The wireless revolution is transforming the existing global telecommunications networks into an integrated system that will provide a broad class of ubiquitous communications services to customers anywhere, anytime, in motion or fixed. Antenna is an important device in WLAN communication system because its performance will directly impact on the quality of wireless communications. The continuous decrease in the size of electronic equipments demands smaller size antenna elements so that they can be properly fit in wireless devices without compromising the other radiation properties of the antenna. In this respect fractal antennas are quite an obvious choice. This project started by identifying two main disadvantages of the typical microstrip antenna that are the low gain and narrow bandwidth. These two major drawbacks have limited its application despite of other advantages as compared to the conventional antenna. Several antenna configurations were proposed and from the simulation result, the antenna bandwidth was improved from the typical 8 ~ 9 % up to 36 % by using these two techniques using a simple coaxial probe feeding without any matching network. A fractal antenna consists of radiating patch placed on the dielectric material with self-repeating structure. Feed line used is microstrip feedline technique. The different types of slots on the patch and the stacking help in increasing the bandwidth and give the efficient results. In this thesis report various antenna designs are given and then study the various effects of different parameters like patch length, patch width, substrate height, and dielectric constant for WLAN applications. The antennas are designed using CST 2014 microwave studio. The antenna parameters like return loss, bandwidth, resonating frequency, directivity, gain and VSWR are calculated for each antenna design in order to get the best antenna.

## Table of Contents

Declaration	i
Acknowledgement	ii
Abstract	iii
Table of contents	iv
List of Figures	vii
List of Tables	ix
List of Acronyms	x
Chapter1:Introduction	1
1.1 Fractal geometry	2
1.2 Fractal dimension	2
1.3 Properties of fractals	3
1.4 Application of fractals	4
1.4.1 Applications in Electrical Engineering	4
1.4.2 Applications in Electrical Engineering	5
1.4.3 Fractals in Stock Market	5
1.5 Types of Fractals	6
1.6 Parameters for measuring antenna's performance	8
1.6.1 Effective height	8
1.6.2 Gain and directivity	8
1.6.3 Front to-Back Ratio	8
1.6.4 Input impedance	9
1.6.5 VSWR	9
1.6.6 Frequency bandwidth	9
1.6.7 Radiation pattern	10
1.7 Advantages and disadvantages	11

1.8 Why fractals are space filling geometries	11
1.9 Fractal shaped antenna elements	12
1.10 Thesis objectives	14
Chapter 2: Literature Review	16
2.1 Fractal antenna element	16
2.2 Research on Sierpinki antenna	17
2.3 Research on Fractal tree	18
2.4 Hilbert curve antenna	18
2.5 Research on fractal patch antenna	19
2.6 Research on random fractal array	20
2.7 Optimization of antennas	21
Chapter 3:Fractal antenna	22
3.1 Introduction	22
3.2 Microstrip line feed	23
3.3 Design consideration for Sierpinski fractal antenna	23
3.3.1 Selection of substrate	24
3.3.2 Element width and length	24
3.3.3 Feed point location	24
3.4 Calculation of design parameters	24
3.5 Antenna design	25
3.6 Simulation result	27
3.6.1 Return loss	27
3.6.2 Smith chart	28
3.6.3 Directivity	29
3.7 Conclusion	29
Chapter 4: Design of novel microstrip feed square triangular corner fractal antenna for UWB applications	
4.1 Introduction	30
4.2 Antenna design	30

4.3 Dimensions of triple band antenna design	31
4.3.1 Ground plane	32
4.4 Simulation	32
4.4.1 Return loss	32
4.4.2 Directivity	33
4.5 Conclusion	34
Chapter 5:Design of crown shaped fractal antenna	35
5.1 Introduction	35
5.2 Antenna design	35
5.3 Dimension of designed antenna	36
5.4 Simulation results	37
5.4.1 Return loss	37
5.4.2 Directivity	37
5.5 Conclusion	38
Chapter 6:Fabrication ,testing and result discussion of fractal antenna	
6.1 Introduction	59
6.2 Simulated antennas resonating at 4.88 GHz	59
6.3 Fabrication process for micro strip patch antenna.	59
6.4 Fabricated antenna design	41
6.5 Testing of antenna	41
6.6 Network analyzer	42
6.7 Results	43
6.8 Conclusion	44
Chapter 7:Conclusion and future scope	
7.1 Conclusion	45
7.2 Future scope	46
References	48
List of Publications	54

- Figure 1.3** : Measured coast line with half the length of ruler
- Figure 1.4** : Block Diagram of Fault Locator
- Figure 1.5** : Construction process of the triad Koch curve
- Figure 1.6** : Radiation pattern of antenna
- Figure 1.7** : Several Stages of sierpinski fractal antenna
- Figure 1.8** : Initial stages of Koch fractal antenna
- Figure 1.9** : Initial stages of Hilbert curve
- Figure 1.10** : A stage Ternary Fractal Tree
- Figure 1.11** : Hierarchical Antenna classification
- Figure 3.1** : Basic procedure for designing fractal antenna
- Figure 3.2** : Micro strip line feed
- Figure 3.3** : Iteration zero of designed antenna
- Figure 3.4** : Iteration first of designed antenna
- Figure 3.5** : Iteration second of designed antenna
- Figure 3.6** : S parameter for zero iteration
- Figure 3.7** : S parameter for first iteration
- Figure 3.8** : S parameter for second iteration
- Figure 3.9** : Smith Chart for designed antenna
- Figure 3.10** : Simulated 2D Directivity
- Figure 4.1** : Zero iteration of designed antenna
- Figure 4.2** : First iteration of designed antenna
- Figure 4.3** : Second iteration of antenna
- Figure 4.4** : Third iteration of designed antenna
- Figure 4.5** : Partial ground plane of the stimulated design
- Figure 4.6** : Simulated Return losses
- Figure 4.7** : Simulated 2D Directivity

**Figure 5.1** : Stimulated antenna design

**Figure 5.2** : S parameter for designed antenna

**Figure 5.3** : 2D directivity of designed antenna

**Figure 6.1** : S parameter for antenna resonating at 4.88 GHz

**Figure 6.2** : Flow chart for process of fabrication of antenna

**Figure 6.3** : Front view of designed antenna

**Figure 6.4** : Back view of designed antenna

**Figure 6.5** : Instrument used for testing

**Figure 6.6** : Devices that can be tested by a Network Analyzer

**Figure 6.7** : Generalized Block Diagram of a Network Analyzer

**Figure 6.8** : Tested results of antenna design

**Table 3.1** : Dimensions of the Patch Antenna Design

**Table 3.2** : Simulated Results of antenna at 8.608 GHz

**Table 4.1** : Parameters for designed antenna

**Table 4.2** :Summary of the Antenna Parameters of Designed Antenna

**Table 5.1** : Parameters for antenna design

**Table 5.2** : Summary of the Antenna Parameters of Designed Antenna at  
4.5 GHz frequency

**Table 6.1** : Tested Results of Antenna Design at 4.88 GHz Frequency

**Table 7.1** : Comparison of all designed Antenna Parameters Values

## List of Acronyms



---

<b>BW</b>	: Band Width
<b>GPRS</b>	: General Packet Radio Service
<b>MPA</b>	: Micro strip Patch Antenna
<b>PC</b>	: Proximity Coupled
<b>RF</b>	: Radio Frequency
<b>Q factor</b>	: Quality Factor
<b>RL</b>	: Return Loss
<b>UHF</b>	: Ultra High Frequency
<b>UWB</b>	: Ultra Wideband
<b>VHF</b>	: Very High Frequency
<b>VSWR</b>	: Voltage Standing Wave Ratio
<b>WiMAX</b>	: Worldwide Interoperability for Microwave Access
<b>CST</b>	: Computer Simulation Technique

Wireless communication is witnessed as the most efficiently and largely growing segment of communication industry, over the last decade we could see the large growth in the utilization of cellular system and approximately around two billion people are using it around the globe. The explosive growth of wireless system along with mushrooming of laptop, palm top computers and cellular phones indicate a bright future for antennas in wireless network [1].

Due to the increase in this trend antennas have become important and essential to modern day human communication [2]. Most of the antennas are required to be robust, small in size and less in weight. These features enable them to be easily placed on the communicating system for enhancement in the portability and for maintaining the performance of the system. As per the tradition an antenna was designed for a particular purpose and each of them were to operate at single or dual band .To find solution to the problem multiband antennas were designed which could be operated at different frequencies. Most antenna for modern wireless communications are complex in structure with irregular metal patches and finite dielectric substrates [3], but some applications demanded the miniaturization of antenna with mounting the large size antenna.

Fractal geometry was considered as the solution to the problem of self similarity property and space filling property of fractal antenna were considered beneficial for multiband or ultra wideband feature and antenna miniaturization respectively. It can be said that the self similarity property of the fractal antennas were transferred into its electromagnetic behaviour [4].This lead into discovery of different types of space filling antennas and their consequences were also considered [5]. This space filing geometry was firstly discovered by B.B Mandelbrot in year 1975 [6].

The word fractal means an object which is fragmented into similar space filling geometry. This branch of geometry had intensive study in late 70's.in mid 90's it came into existence that properties of such space filling geometry could be used to design antennas which had properties such as frequency selective structure ,multiband and wideband etc [7].

## **Fractal geometry**

Fractal geometry was established due to Benoit Mandelbrot. Fractals were discovered as mathematically define structures. The dimension of these structures was not limited to whole numbers.

Benoit Mandelbrot coined the term fractal in 1975 which was derived from Latin word 'fractus' which means made up of broken or irregular fragments. These geometries were used to classify the structures in nature which were not definable with Euclidean geometries .example of such geometries are branches of tree, density of clouds, length of coastline [7].

Fractals represents a group of geometry with unique property that was very useful for antenna designers. Fractals had properties due to which their electrically large features were efficiently packed into small areas [8].

Fractal antennas are said to be augmentation of classical antenna which are based on fractal geometry. Thus the fractal geometry and antenna theory from the background of fractal antenna.

### **1.2 Fractal dimension**

A fractal dimension is an index for distinguishing fractal patterns by quantifying their dimensions as a ratio of change in detail to change in scale [9]. Mandelbrot explained the dimensions of fractal geometry by taking in consider the question "how long is the coast of British".

The coastline can be said to be fractal on shape it was asymmetrical ,so to democrat it with straight ruler, as shown in figure 1.1 provided an estimate the calculated length  $L$  which was equal to the length of ruler  $R$  multiplied by  $n$  the no. Of such rulers needed to cover the coastline .in figure 1.2 a part of coastline was demarcated twice but the ruler in figure 1.3 is half to that used on figure 1.2.even if we halved the scale we will get similar result, a longer estimate of  $L$ .in general length of ruler is inversely proportional to length to be measured. so if length of ruler is small the length of coastline to be measured will get large. Due to this the concept of length began to make less sense .for example of coastline it could be concluded that dimension of coastline is greater than 1 but less than 2.More wiggly the coastline, more it is near to 2.Such lines can be described as space filling curve because it nearly fills a space the line must have dimension close to 2.



Figure1.1 Coastline of British

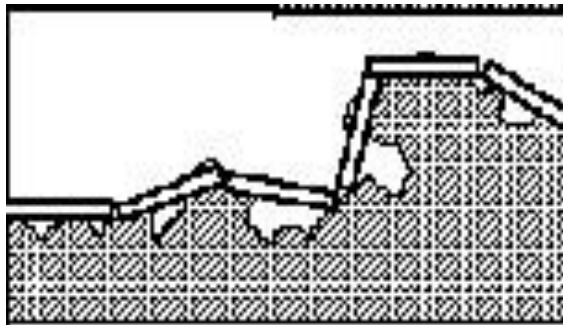

Figure 1.2 Measured coast line with ruler

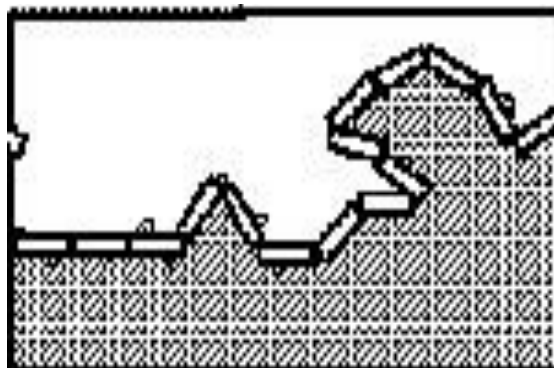

Figure 1.3 Measured coast line with half the length of ruler

### 1.3 Properties of fractals

Fractals come under class of geometry with very useful properties that are as follow:

- Self repeating
- Fractal dimension
- Formation by iteration
- Space filling.

## 1.4 Application of fractals

The application of fractals in the engineering sciences is increasing rapidly. Through the output of this research it can be seen that in real industrial situations with recent progress is made in areas such as chemical engineering, internet traffic, physics and finance. Image processing continues to be a major field of application for fractal analysis.

### 1.4.1 Applications in Electrical Engineering

There are various applications of fractals in electrical and electronics engineering field some are:

#### 1.4.1.1 Impedance Fault Detection in Power Systems,

High impedance faults are very difficult to be predicted as when they occur they do not extract enough current which is required for detection system to operate. Phase currents and voltages in a distribution power system are affected when high impedance faults (HIFs) occur. So concepts of fractal geometry is used to analyze chaotic properties of these faults. These faults also fail to establish return path. When fault occurs. It melts conductor due to which arc is produced, soil is displaced etc. This causes current very chaotic. FD is used for measuring this fault as shown in Figure 1.4 [10].

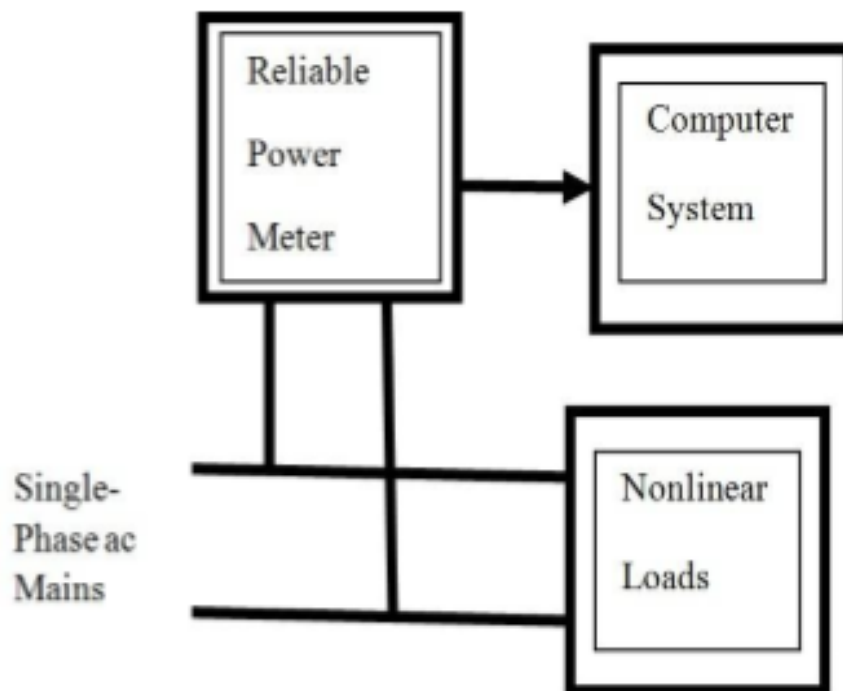

Figure 1.4 Block Diagram of Fault Locator

### **1.4.1.2 Fractal capacitor**

The density of a fractal capacitor can be increased using scaling. The dimension of the fractal is one of the factor on which the capacitance per unit area of a fractal structure depends .as fractals are said to be space filling contour so fractals with large dimensions should be used. Fractals also allow the capacitance density to be adjusted for a lower series resistance. The effective series inductance can be reduced by the use of fractals, as fractals randomize the direction of current flowing through them [10].

## **1.4.2 Applications In Electronics Engineering**

### **1.4.2.1 Fractal Encoding in Communication**

Fractal-coded images are seen to have low complexity decoding scheme [11]. The fractal-based compression uses local self repetition in images of textures and natural scenes. Both storage and transmission bandwidth are saved due to the use of fractal image texture. Fractal compression/decompression could pass the JPEG standard in mobile applications.

### **1.4.2.2 Fractal Image Compression**

The algorithm used in compressing of an image is

- Detecting the bits available and distortion (tolerable error) parameters for the image to be compressed.
- Image data is then divided into various groups, based on their importance.
- Available bit budget is divided into these groups, in such a way that the distortion is a minimum.
- Quantization of each group is done separately using the bit allocation information derived in above step
- An entropy coder is used to encode each group separately and write to the file.

### **1.4.3 Fractals in Stock Market**

Fr Benoit Mandelbrot, who is known as the father of fractal geometry, used the principals of fractals to explain stock markets [11].

A study on stock market say that they are non predictable. The change in market on some days is very small but on some days we can see a huge leap change. This kind of random change could only be explained using fractals.

Mandelbrot explained many market bubbles and market crashes. He explained that fractal techniques can be the most powerful technique to analyse risk, and so they can be applied to financial data for better estimation for risk .so fractal notions can be used to study the principles on how stock markets work. So, by computing the fractal dimension of data charts it can be examined whether the day was of high turbulence and volatility. Fractal dimension of data chart can be varied from 1.15 to 1.4. The high fractal dimension of a data chart denotes that the day (or period) had high turbulences and volatility. On the chart we can observe the up and down of the line.



Figure 1.5 graph of Indian stock market 2014-2015

### 1.5 Types of Fractals:

Fractal comes into two major variations [13]

- Deterministic fractal
- Random fractal

The deterministic fractals are those fractals that are composed by severely iterated and rotated to form self similar copies, such as Koch curve .They are also known as geometric fractals. Julia set also comes under same category. The whole set can be derived by using a non-linear iterated map which is applied to all small section of it. They are also said to be algebraic fractals. Hence both algebraic and geometric

fractals are classified under deterministic fractals. Since the generation of such fractal requires mapping or a certain rule which is repeated over and over again, they possess the property of self repeating.

The second category (Random Fractals) includes those fractals which have high degree of randomness which allows them for simulation of natural phenomenon, so they show the property of statistical self similarity. [12]

**Geometric Fractals:** The fractals of this category are ocular. In two-dimensional case they are shown as broken lines (or of a surface in three-dimensional case) which are called the generator. Each part of fractal is replaced by broken line generator at corresponding scale for forming an adequate algorithm. As a result of never-ending repeating of geometrical broken lines fractal arises.

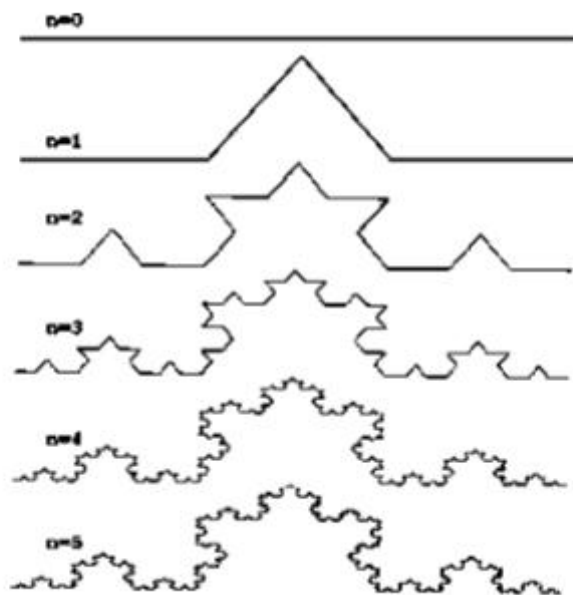

Figure 1.6 Construction process of the triad Koch curve

Construction process begins with the use of segment of single length (Figure 1.6). It is said to be the zero iteration of the Koch curve. Then each segment (one segment in zero iteration) is substituted by an element defined on the figure 1.6 as  $n=1$ . Due to the substitution the next iteration of the Koch curve is derived. Then in the same way next three sections are derived and are successively reduced by  $1/3$  length of the first iteration. Thus, to construct the next iteration, all pervious iteration is substituted by self similar curves scaling down itself at particular rate which is  $1/3$  in this case. The

curve of x-th iteration is known as prefractal when x is finite number. When x is infinite number the curve formed is said to be a fractal object [14].

**Algebraic fractals:** Algebraic fractals form the largest group of fractals. They are formed by applying different nonlinear processes in x-dimensional spaces.

**Stochastic fractals:** The stochastic fractals are formed by applying accidental parameters to the iterating processes. It uses the same process as the natural fractals are created. Two dimensional stochastic fractals are used for designing surface of sea or relief modelling [15].

## **1.6 Parameters for Measuring Antenna's Performance**

### **1.6.1 Effective Height**

The effective height of an antenna is defined by how effective an antenna can act as a transmitter or receiver of Electromagnetic wave energy. It indicates how far an antenna is the effective in transmitting and receiving the electromagnetic energy. In telecommunication, the effective height of an antenna is the height of the antenna's centre of radiation above the ground. It is defined as the ratio of the induced voltage to the incident field.

### **1.6.2 Gain and Directivity:**

Antenna gain is measured by antenna's ability to direct or concentrate radio frequency energy in a required direction or pattern. Gain helps in making the apparent power greater than the actual transmitted power of an antenna in the required direction.

Directivity is a measure of performance of an antenna. Directivity is defined as the relation of the maximum radiation intensity to the average radiation intensity. Antenna with directivity 1 will radiate equally in all the directions, such kinds of antennas are called isotropic radiators, but practically no such antenna exists. Gain becomes equal to directivity if the efficiency achieved by antenna comes out to be 100 percent. Generally  $D > 1$  except in case of an isotropic antenna. As in isotropic antenna  $D = 1$ . an antenna which has directivity  $D \gg 1$  is known as directive antenna.

### **1.6.3 Front to-Back Ratio (FBR)**

Gain received from front of the antenna is not equal to gain received from the back of the antenna in a directional antenna. Difference calculated in the power gain from front of antenna to rear of the antenna is called front to back isolation ratio of

antenna.FBR is an important measure to keep in notice when the antenna is to be placed in an crowded frequency band.

#### **1.6.4 Input Impedance**

For antenna to dissipate all the power present, impedance needs to be purely resistive. For this condition maximum power transfer should be achieved which can be done by matching the input impedance of antenna input impedance of transmission line. It should be noted that the input impedance of antenna should be resistive so that the power input to the antenna is equal to power output from the antenna. Input impedance is represented by real and imaginary parts and its general form is:

$$\mathbf{Z_{in}=R_{in} + jX_{in}} \quad (1.1)$$

Where in R represents the resistance or power radiating, X represents the reactive portion or power storage component of the impedance. Power dissipated depends on the following

- Ohmic or heating losses dissipated from the antenna.
- Powers in the form of electronic electromagnetic waves also get dissipated at the given frequency.

#### **1.6.5 VSWR**

Impedance mismatching between the antenna and transmission line is represented by voltage standing wave ratio (VSWR). A perfect matching is achieving when the results obtained are 1:1 and worst case is achieved when results obtained are  $\infty$ :1.

#### **1.6.6 Frequency Bandwidth (FBW)**

The bandwidth of an antenna is an essential factor for deciding the frequency range. Bandwidth and frequency are measured in the same units: Hz, also known as cycles per second. Roughly speaking, bandwidth is the difference between the highest and lowest frequency transmitted over a channel. With this definition, it is clear that the bandwidth cannot be larger than the highest transmit frequency. Usually the bandwidth is much, much smaller than the transmit frequency and is sometimes given as a percentage. When the FCC or other regulatory body allocates portions of the spectrum for use, they specify many things, including the allowed bandwidth. The commercial radio transmitters have narrow bandwidth as they generally transmit on single bandwidth whereas the receiver antenna should have large bandwidth so that it

could be operated on the other bandwidth as well. Antennas depending on the frequency range they work are divided into three classes

- Narrow band: These antennas cover a small range of the order of few percent around the designed operating frequency.
- Wideband or broadband – these antennas cover an octave or two range of frequencies.
- Frequency Independent- These antennas cover a ten to one or greater range of frequencies.

### 1.6.7 Radiation pattern:

A radiation pattern is the deviation of the power radiated from an antenna as with respect to the direction in which the antenna is radiating [16]. It is the measure of antennas power or radiation distribution with respect to a particular type of coordinates. Ideal antenna is supposed to radiate in a spherically symmetrical pattern. However in practical cases antenna is not omni-directional but have a radiation maximum along one particular direction [17].

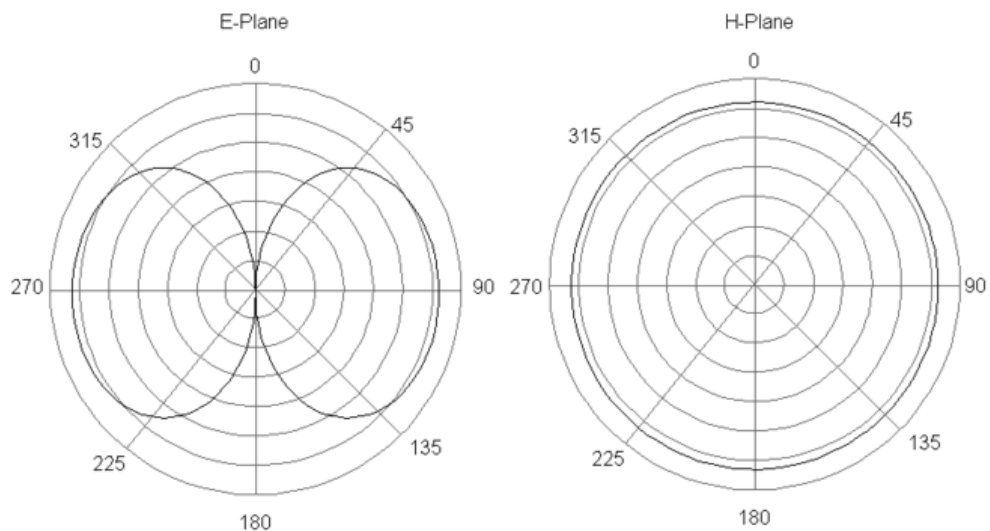

Figure 1.6 Radiation pattern of antenna

The radiation pattern plot is useful for quickly evaluating the usefulness of an antenna for a certain application. For example, Gain, directivity are parameters that a radio systems engineer would use to choose an antenna for a specific job, i.e. an Omni-directional antenna would be used for wide area coverage, like for a television

transmitter, while an antenna with a narrow beam width would probably be used as a television receiver antenna because of its large gain in one direction and its ability to screen out interference from the sides and back.

### **1.7 Advantages and Disadvantages**

There are many benefits when we applied these fractals to develop various antenna elements. By applying fractals to antenna elements:

#### **1.7.1 Advantages of fractal antenna:**

- Antenna size can be reduced so it lowers the cost and increases the desirability.
- Achieve resonance frequencies that are multiband.
- May be optimized for gain.
- Multi band and wideband frequency band can be achieved. Due to this we use 1 antenna instead of many antennas.
- Fractal antennas are specially designed for harshest conditions so are used by military and commercial customers.
- These antennas have low mutual coupling due to which close packing of antennas are possible. This makes the arrays with excellent steer ability

#### **1.7.2 Disadvantages of fractal Antenna:**

- Loss in the Gain.
- It has numerical limitation.
- It is very complex.
- After few more iterations, it degrades the antenna parameters.

Further investigations and new developments in this field may be helpful in overcoming these disadvantages.

### **1.8 Why Fractals are space filling geometries:**

Euclidean geometries are limited to points, lines, sheets & volumes, Fractal include geometries that fall in between these distinctions .Therefore, a fractal can be line that approaches a sheet. These space filling properties lead to curve that are electrically very long [18], but fit into a compact physical space. This property leads to miniaturization of antenna elements. Fractals could be used to define the spacing in arrays for thinning or to define radiation pattern [19]. With successive iteration the

length of Koch increases by 1/3 of the original length. Length of Koch after nth iterations:

$$l_n = l_0 \left(4/3\right)^n \quad (1.2)$$

Where  $l_n$  and  $l_0$  are the length after nth iteration and original length (without any iteration) respectively.

For Sierpinski Triangle with each iteration the area of the holes and circumference of solid pieces changes. If the area of original triangle is 1, then first iteration removes 1/4 of the area, second iteration removes a further 3/16 and third iteration 9/64.

Then total area removed after the nth iteration

$$A_N = 1/3 \sum_{i=1}^N (3/4)^i \quad (1.3)$$

If circumference of original triangle is 1, then after first iteration the circumference increases by 1/2. After second iteration it increases by 3/4, after nth iteration. This means gasket has no area but boundary is of infinite length.

$$C_N = 1 + 1/3 \sum_{i=1}^N (3/2)^i \quad (1.4)$$

$$C_\infty = \infty \quad (1.5)$$

## 1.9 Fractal Shaped Antenna Elements

As with several other areas, the nature of fractal geometries has been the area of interest of antenna designers, primarily as a past-time. This has led to the introduction of new types of antennas, called fractal shaped antennas. Cohen has experimented and find out the usefulness of different types of fractal geometries. Koch curves, Murkowski curves, Sierpinski gasket are types of fractal shapes. The first fractal that was evaluated was the popular Sierpinski gasket [20]. The initial stages in the construction of the Sierpinski gasket are shown in Figure 1.7 Another popular fractal is the Koch snowflake as shown in Figure 1.8 [21]. Initiator of this fractal is a solid

equilateral triangle in the plane, as shown in of Figure 1.7 number of shapes and designs based on periodic or random fractal trees has also proven to be extremely useful in developing new design methodologies for antennas and frequency selective surfaces. An example of a deterministic ternary (three branches) fractal tree is shown in Figure 1.10. Due to the space-filling properties of the Hilbert curve and related curves make them attractive candidates for designing of fractal antennas. The first four steps in the designing of the Hilbert curve are shown in Figure 1.9. The Koch snowflakes and islands have been primarily used to develop new designs for miniaturized-loop as well as Micro-strip Patch Antennas. New designs for miniaturized dipole antennas have also been developed based on a variety of Koch curves and fractal trees. Finally, the self-repeating and similar structure of Sierpinski gaskets and carpets has been used to develop multi-band antenna elements as can be seen below in the figures

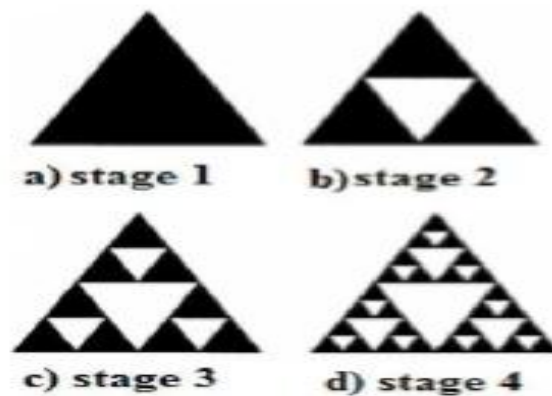

Figure 1.7 Several Stages of Sierpinski fractal antenna

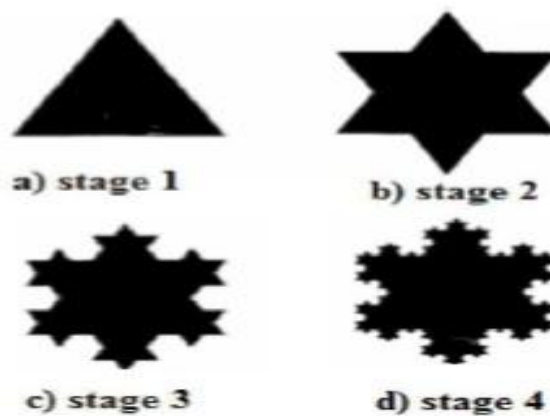

Figure 1.8 Initial stages of Koch fractal antenna

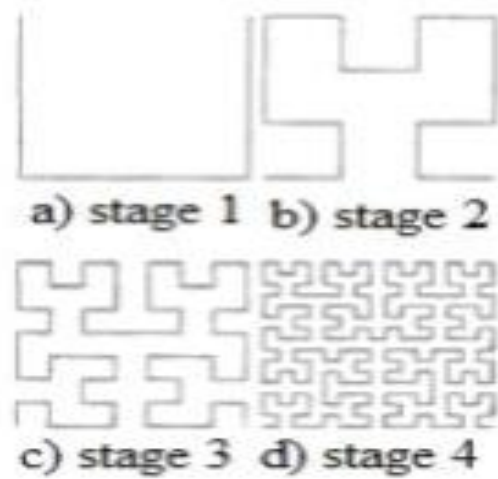

Figure 1.9 Initial stages of Hilbert curve

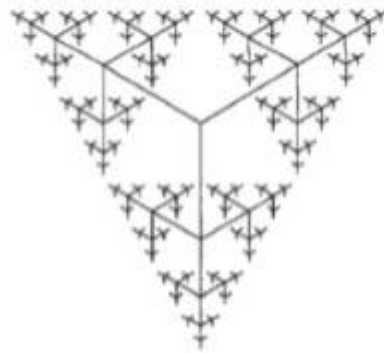

Figure 1.10 A stage Ternary Fractal Tree

These geometries are made up of tips and corners, this fact help them to improve antenna efficiency. Fractal trees when explored further were found to have multiband characteristics. Self-similarity of the geometry was one of the sole reasons for the multiband characteristics of these antennas.

### **Thesis objectives**

- The main objective of this thesis is to design ,fabricate and testing of the fractal patch antenna using different feeding techniques
- The other job is to improve return loss and gain of the fractal shaped antenna.
- To plot frequency versus return loss plot of fractal antenna at different iteration to show multiband behaviour of fractal antenna
- To plot improved radiation pattern of fractal antenna at different iteration.
- To design fractal antenna of reduced size and multiband characteristics.

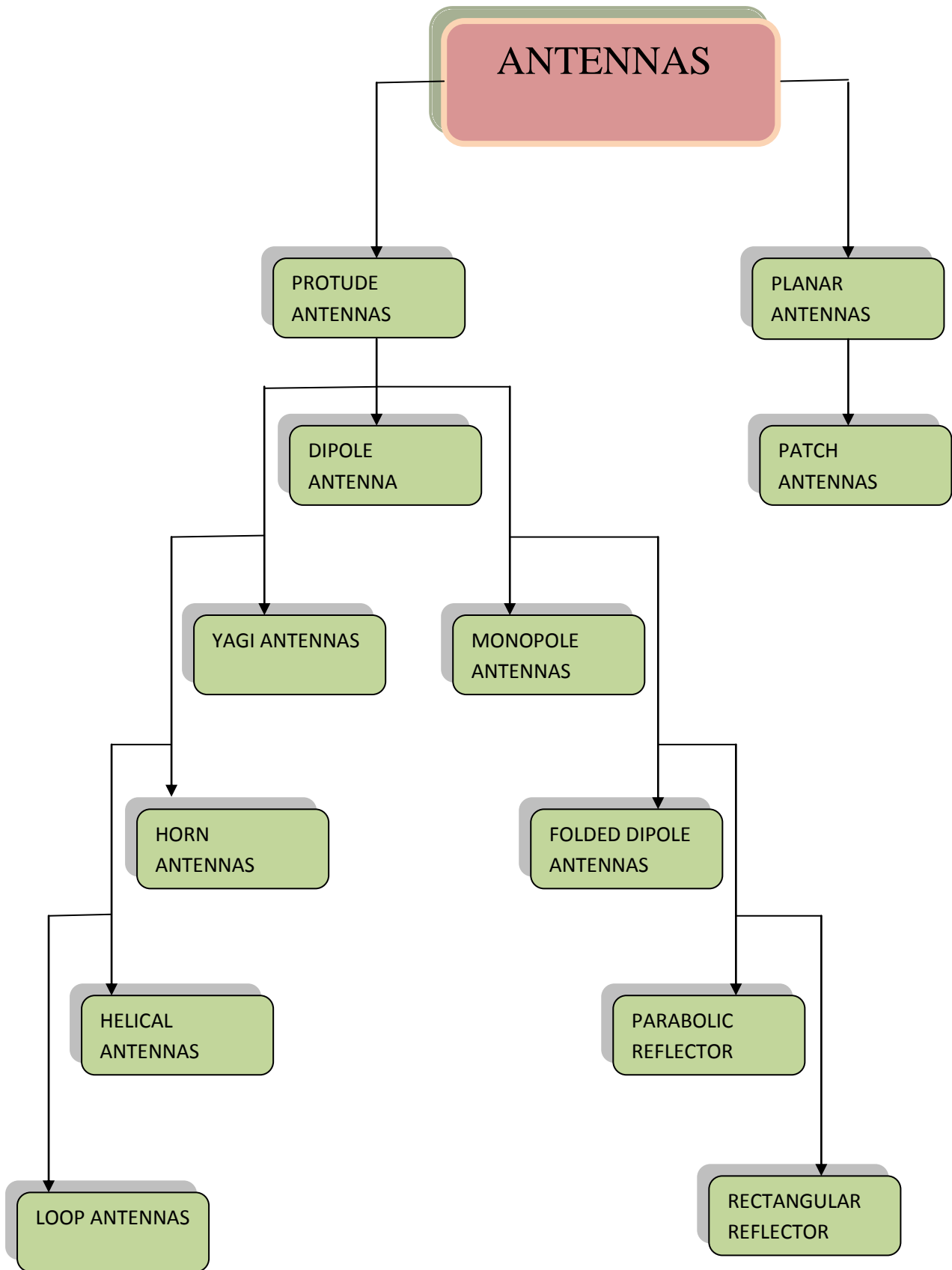

Figure 1.11 Hierarchical Antenna classification

In this chapter advances in fractal antenna are studied. Since last decade contribution of fractal geometry in design of antenna in order to make it multiband and smaller in size. A number of designs studied and researched by various researchers included in this chapter. Applications to wireless communication systems in different fields have been reviewed. An account of some research in optimizing such antenna is also presented.

#### 2.1 Fractal Antenna Element

##### Early Work on Fractal Loop, Dipole, and Monopole Antennas

**In 1986 Y.kim *et al.* [22]** presented publically for the first time a new approach to random array synthesis .This new approach was based on the application of underlying self similarity property in random fractals to the problem of antenna array theory. Different examples that discussed the synthesis procedure and its advantage in presenting robust, low side lobe arrays.

**In 1995 N Cohen [23]** presented first scientific publication on fractal antenna. In this he presented the application of fractal geometry for designing of antenna elements. This was achieved by bending the wire in order to form miniaturized antenna designs.

**In 1996 C. Puente *et al.* [24]** discovered a new method based on fractal structures for multiband operation. The same was presented by two different approaches i.e. for fractal spatial arrangement of array elements and for fractal design of array factors. Such structures were found beneficial for designing low side lobe array .fractal array factors demonstrated kept the same shape at different bands due to their self similarity property.

**In 1997 N Cohen [25]** finally studied that applying fractals to antenna elements allow them to be optimized for gain and for multiband /broadband. He proved that fractal antenna were worthwhile and had high performance in many application .Moreover they were also discovered to be versatile in the field of wireless application.

In 1999 N Cohen [26] finally studied the effects of various types of symmetries on the performance of Koch dipole antennas.

## 2.2 Research on Sierpinski

In 1996 Puente *et al.* [27] designed a sierpinski gasket based fractal multiband antenna .it was experimented and results were commuted to show the multiband behaviour of new fractal sierpinski antenna. The antenna worked over five bands and the behaviour was shown due to the self similar shape of the fractal antenna which means that the shape of antenna is repeating and similar at different scales this helped to discover more new ways for designing new multiband and frequency independent antenna .An equilateral triangle is chosen as the initiator /generator for generating triangular sierpinski gasket antenna .antenna is mounted upside down in order to simplify the antenna feeding scheme. Antenna produced self similar shape at 5 different scales spaced by factor of 2. Both stimulated and experimented results showed that self repeating properties of fractal shape are translated into electromagnetic behaviour.

In 2000 Baliarda *et al.* [28] explained the multiband behaviour of sierpinski fractal antenna. He explained that the fractal antenna shows multiband behaviour because of its self repeating nature. This property was used to predict the behaviour of antenna when flare angle was modified.

In 2001 J romeu *et al.*[29] presented further discoveries in multiband behaviour of sierpinski which lead to the new set of fractal multiband antennas. These antennas were called mop-p sierpinski gasket antennas. He showed that mop-p sierpinski fractal antenna was derived from Pascal triangle and showed same log periodic behaviour as sierpinski fractal antenna. Mop-p sierpinski fractal antenna constitutes a generalization of classical sierpinski antenna.

In 2000, J. Soler *et al.* further discovered and presented the reduced size dual band sierpinski fractal antenna [30].

In 1998 C. Puente *et al.*[31] showed that with change in flare angle change in input parameter and radiation pattern could be seen by decreasing the flare angle deviation from multiband behaviour is obtained.

### **2.3 Research on fractal tree**

In 1996 C. Puente [32] was the first to introduce and use the term fractal tree. It was presented that fractal tree structure antenna was generated by electrochemical deposition. New antenna formed had denser distribution in comparison to sierpinski fractal antenna.

In 1999 M sindou [33] considered the calculated and experimented results to present that input reflection coefficient of a fractal tree antenna exhibited a multiband behaviour which were generated due to the element of successive iteration levels. These further results into large number of elements at the last iteration which results in wideband response of antenna.

In 1999 D.H Werner *et al.* [34] presented the multiband electromagnetic behaviour of fractal tree antenna. A three band monopole structure was considered to calculate the required results. Tree fractal antenna showed properties that were better and not similar to that of sierpinski monopole counterparts.

In 2002 S. Petko *et al.* [35] further studied to show the ways to miniaturizing the antenna by making required changes in fractal tree .the tree antenna was employed at ends loads by increasing the number of branches which means that the fractal dimension of the antenna was higher.

In 2004 S. Petko [36] investigated a new design for miniaturizing and reconfiguring the 3D fractal tree antenna. It was discovered that the density and elevation angle act as some main factors for effective design of miniature 3D fractal tree antennas. Other multiband and reconfigurable fractal tree antenna which had LC traps or RF switches placed at branches and/or along trunk of tree antennas were also presented. Using this technique 57% in size reduction of centre frequency and tunable bandwidth up to 70% could be achieved.

### **2.4 Hilbert curve antennas**

In 2001 K. J. Vinoy *et al.* [37] studied Hilbert curve, which was then one of the most recent geometries to be studied. Discovered the Hilbert curve fractal antenna with configurable characteristics. The predictable orders of the Hilbert curve antenna make it easy to be generated and reproduce in comparison to other miniaturised antenna.

Changes in radiation pattern could be noticed only by adding interconnecting segments to the antenna designs. RF switches are one of those added segments which made the radiation pattern reconfigurable it was shown that in the same way if we connect the switches in series along the length of antenna then it results in frequency tuning characteristics.

In 2002 J. Anguera *et al.* [38] introduced a novel miniature antenna which was based on Hilbert fractal curve. In this he showed that the fractal length of the Hilbert curve antenna could be made smaller by high increase in the fractal iteration. Many fractal shaped Hilbert curve monopoles were designed, experimented and compared with classical  $\lambda/4$  monopole. It was seen that the wire length of the Hilbert monopole which was increasing at each iteration and calculated as

$$L(n) = \frac{4^{n+1} - 1}{2^{n+1} - 1} \quad (2.1)$$

In 2005 Xue sang yang [39] proposed novel reconfigurable Hilbert curve patch antenna. The patch was designed up to 3<sup>rd</sup> order Hilbert curve. Different radiation patterns were achieved by introducing some slots to the antenna curve. Radiation patterns were reconfigured MEMS antenna. This produced application in the Telecommunication systems or radar systems.

In 2007 N. Prombutr [40] proposed the Hilbert curve antenna that received and transmitted at many frequency resonances but the first frequency resonance was 1.8 GHz band and others were higher than it. By experimenting and calculating we found out that percentage(%) of difference for the given antenna is measured to be lower than 4.6%. so this empirical model is helpful to design Hilbert curve fractal antennas. The antenna characteristics were found to be dictated by the outer dimension.

## 2.5 Research on fractal patch antenna

In 2000 J. Romeu *et al* [41] presented a design for multiband sierpinski micro strip patch antenna. This was done in order to enhance the multiband behaviour of the radiation patterns by reducing the effects caused by high order modes of antenna.

In 2001 Zhengwei du *et al* [42]. Investigated and found the square micro strip fractal patch antenna and the effects were thus analysed. Results thus obtained showed the

multiband frequency. Operation of the propose antenna result from driven element and not from parasitic fractal elements.

In **2002 Liu ying *et al.* [43]** did further advancement in this field and proposed a design for three band operation. This type of antenna had great application in wireless satellite and mobile communication application.

In **2001 Jaume anguera *et al.* [44]** proposed fractal shaped antenna with more improved and better performance were noticed in the size, gain or multiband behaviour of fractal shaped antenna.

In **2014 N. Rao *et al.* [45]** presented the first report on novel mushroom type electromagnetic band gap structures which consisted of fractal periodic elements which was used for increasing the gain and directionality of the fractal patch antennas. ebg substrates are used for the fractal as ebg are said to be good in suppressing surface wave which causes higher gain. Thus the gain was improved from 6.38 dBi to 10.5 dBi.

## **2.6 Research on random fractal array**

In **1986 Y. Kim *et al.* [46]** introduced a new method of random array synthesis. The new property depends on self repeating property of random fractals. Different fractal shapes were used as example for synthesis of the procedure. This was enhanced and preferred due to its robustness and low side lobe array.

In **2004 J. S. Petko *et al.* [47]** presented a new class of arrays which include both the properties of fractal and random array .The two main types in which arrays can be divided are periodic array and random array. Periodic array decreases the radiation pattern side lobes just by using few numbers of elements but it is more prone to element failure where as random array are robust to element failure but are not good in suppressing side lobes.

In **2009 J. S. Petko *et al.* [48]** further presented in the paper that mutation was performed again and again on each member of population and new result is perturbed by small amount. To obtain the best required solution the process was repeated again and again. It was thus shown that generator mitosis when progressively used give

external multiple generator fractal random array from deterministic array with large element counts.

## **2.7 Optimization of antennas**

**In 2010 E. oliversia *et al.* [49]** proposed an optimization of the input impedance of Koch triangular quasi fractal antennas using an efficient genetic algorithm. Inset fed is used for the purpose of impedance matching and this in turn minimizes the return loss. The excitation to the antenna is given by micro strip line. The new structures which are optimized by genetic algorithms show enhanced results. The return loss for the same are shown below -40dB at resonant frequency.

### 3.1 Introduction

In this chapter, the basic procedure for designing a sierpinski triangular shaped fractal antenna has been presented. The design of the antenna has been explained in four major steps. In the initial step the fractal Antenna is designed using CST studio 2014. Antenna is simulated on CST and the design parameters are verified. The best result obtained is used such that fractal geometry is incorporated into the design. The final step involved studying the characteristics of sierpinski fractal antenna. The basic design procedure for fractal antenna is explained below flow chart:

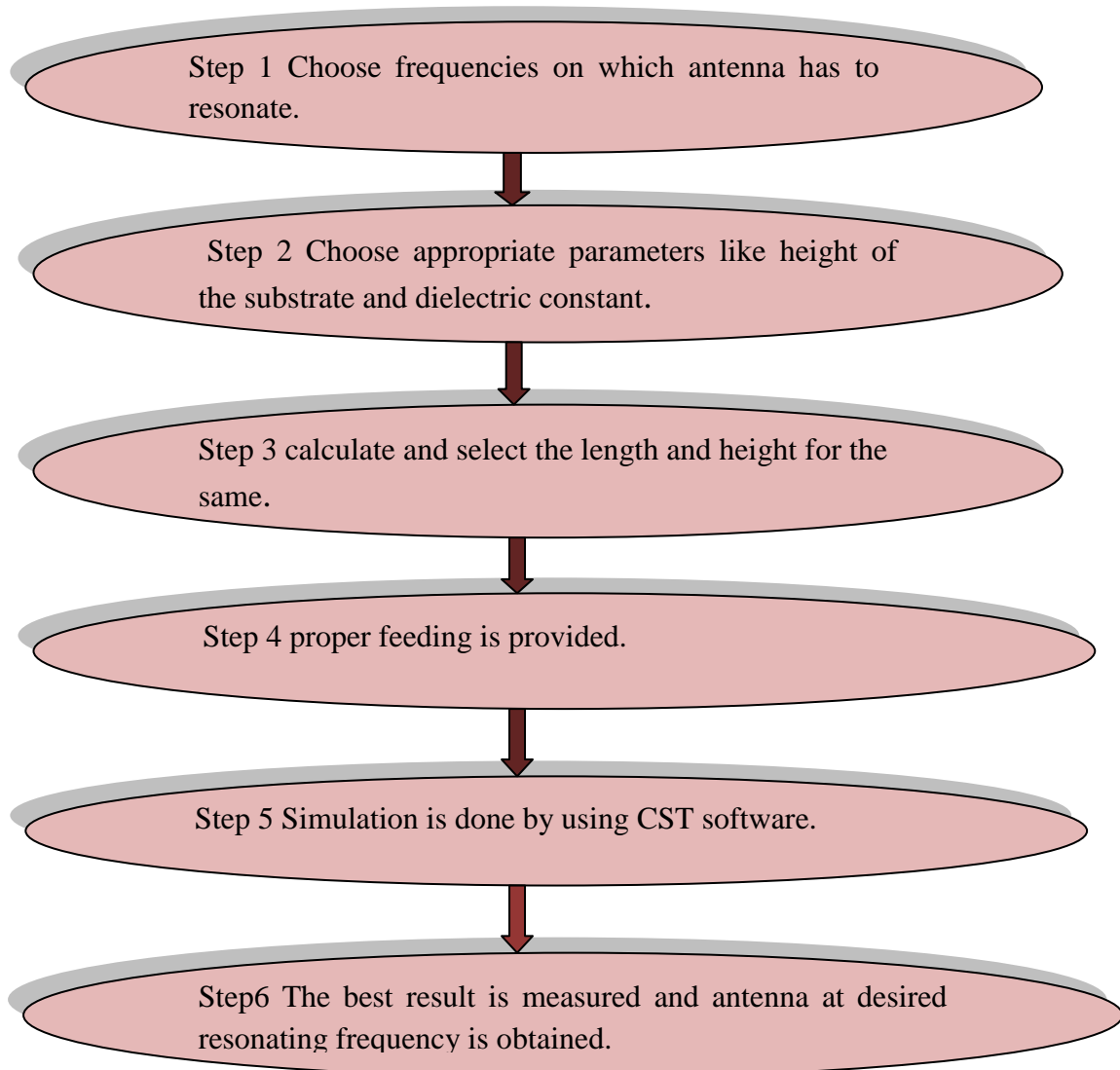

### 3.2 Micro strip Line Feed

This kind of feed technique is shown in the structure below i.e. in Figure 3.2. A conducting strip is connected directly to one end of the patch. Width of this conducting strip is smaller in comparison to the patch. This kind of feed arrangement has the advantage of this kind of feed arrangement is that the feed can be etched on the same substrate. This provides a planar structure to the antenna.

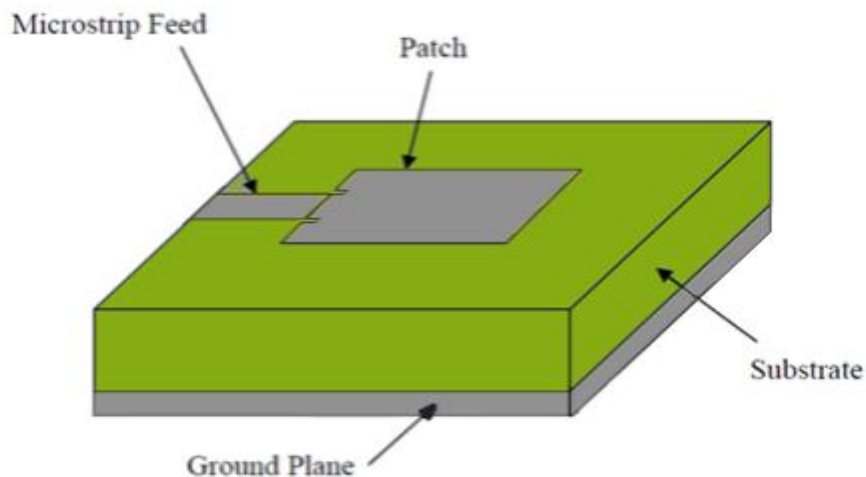

Figure 3.2: Micro strip line feed [50].

The inset cut that can be seen in the patch has a purpose to match the impedance of the feed line to the patch without the requirement for any additional matching element. This is achieved by properly designing the position of the inset. Hence this is an easy feeding scheme, since the process of fabrication is easier in this kind of feed line in comparison to other feed lines. It is simpler in modelling as well as in impedance matching. However; an increase in thickness of the dielectric substrate, gives an increase in surface waves and spurious feed radiation, this hampers the bandwidth of the antenna. The feed radiation also leads to undesired cross polarized radiation [51].

### 3.3 Design Considerations for sierpinski fractal Antennas

Based on the requirement, the length and width of sierpinski gasket for a given dielectric constant and resonant frequency of the antenna is chosen and the patch size is designed accordingly. A sierpinski antenna element can be used alone or in combination to form an array. In either case, the designer should follow a step-by-step design procedure. Usually, the main motive of a design is to achieve the require

performance characteristics at a stipulated operating frequency. If a sierpinski antenna configuration can achieve these required goals, then the first decision is to select suitable antenna geometry. A sierpinski gasket can be designed using the procedure described in the next subsection.

### **3.3.1 Selection of substrate**

The first step in the process of designing the antenna is to choose a suitable dielectric substrate with appropriate thickness  $h$  and loss tangent. A thicker substrate, is not only mechanically strong, but also increases the radiated power. It also reduces the conductor loss, and improves impedance bandwidth of the antenna. However, due to this the weight, dielectric loss, surface wave loss, and extraneous radiations from the probe feed increases. The substrate dielectric constant  $\epsilon_r$  plays a role similar to that of substrate thickness. If the value of  $\epsilon_r$  for the substrate is decreased then fringing field at the patch periphery is increased, and thus the radiated power. Therefore, substrates with  $\epsilon_r = 4.4$  are preferred. Here substrate thickness  $h=1.6\text{mm}$  and dielectric constant  $\epsilon_r=4.4$  are considered for the desired antenna.

### **3.3.2 Element Width and Length**

Based on the simplified formulation, a design procedure is followed which leads to practical designs of fractal antennas. The procedure assumes that the given information includes the dielectric constant of the substrate ( $\epsilon_r$ ), the resonant frequency ( $f_0$ ), and the height of the substrate  $h$ .

### **3.3.3 Feed Point Location**

After selecting the length and width of a patch for a given substrate, the next important task is to determine the appropriate feed point so that a good impedance match between the generator impedance and the input impedance of the patch element could be achieved. It can be seen that the change in feed location gives rise to a change in return loss. The feed line in micro strip feed line technique should end below the patch.

## **3.4 Calculation of Design parameters**

The subsection below contains the calculation of various parameters and dimensions required for designing of antennas to resonate at desired frequencies. Equations pertaining to design sierpinski antennas are also presented in this chapter.

Calculation of the width W of antenna, which is given by:

$$f_o = c / 2\sqrt{\left\{\epsilon_{reff} \left[ \left( \frac{m}{L} \right)^2 + \left( \frac{n}{W} \right)^2 \right]^{1/2} \right\}} \quad (3.1)$$

Where m and n are modes along L and W respectively, fo is the resonance frequency and W is the width of patch.

Calculation of effective dielectric constant,  $\epsilon_{reff}$ , which is given by:

$$\epsilon_{reff} = \left( \epsilon_r + 1 \right) / 2 + \left( \epsilon_r - 1 \right) / 2 \left[ 1 + 12W / h \right]^{1/2} \quad (3.2)$$

Where  $\epsilon_{reff}$  is effective dielectric constant,  $\epsilon_r$  is dielectric constant of substrate, h is height of dielectric substrate, W is width of the patch.

Calculation of the effective length,  $L_{eff}$  which is given by:

$$L_{eff} = L + 2\Delta L \quad (3.3)$$

Calculation of the length extension,  $\Delta L$ , which is given by:

$$\Delta L = 0.412h \left( \epsilon_{reff} + 0.3 \right) \left[ W / h + 0.264 \right] / \left( \epsilon_{reff} - 0.258 \right) \left[ W / h + 0.8 \right] \quad (3.4)$$

Ground plane dimension LS and WS which are given by

$$L_g = 6h + L \quad (3.5)$$

$$W_g = 6h + W \quad (3.6)$$

### 3.5 Antenna Design

We have calculated the parameters required for designing the square from equations described in Section 3.5. The radiating patch is printed on the upper side of the substrate. The length of the generating square is 17.7 mm. The substrate used for designing the antenna is made up of FR4. The FR4 substrate used is having dielectric constant of 4.4 and height of the substrate is 1.6 mm. The feed line of the designed

antenna is etched on the upper side of the substrate. The length of feed line is 11.6mm.

Variable	Value
Total Length of substrate	35.4mm
Total Width of substrate	35.4mm
Height of substrate	1.58mm
Width of feed line	4mm

Table 3.1 Dimensions of the Patch Antenna Design

The designed antenna is simulated using CST 2014 studio. It is shown below:

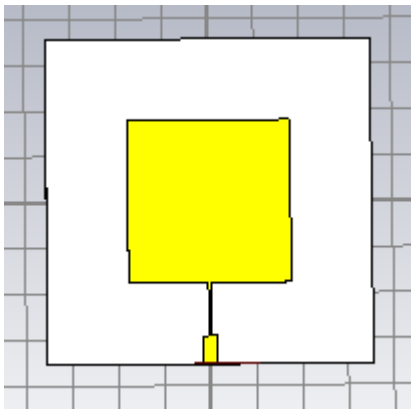

Figure 3.3 Iteration zero

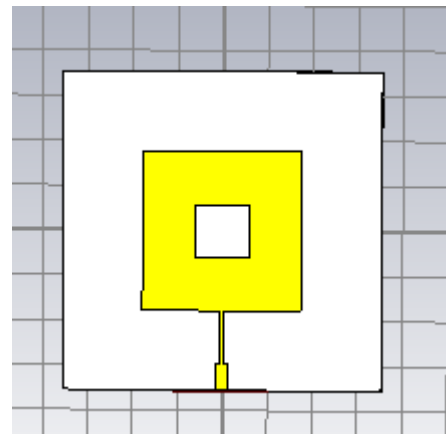

Figure 3.4 Iteration first

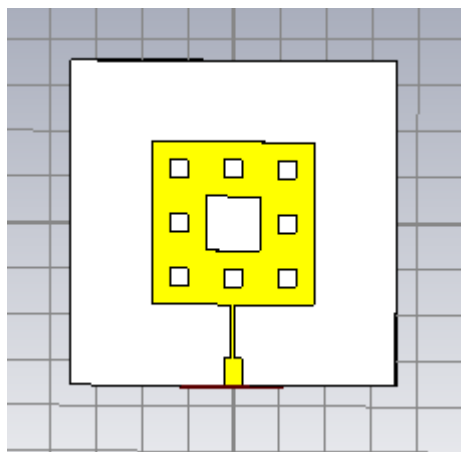

Figure 3.5 Iteration second

### 3.6 Simulation Results

#### 3.6.1 Return loss

The designed antenna is stimulated using CST 2014 for different parameters like return loss, impedance, gain, directivity and VSWR.

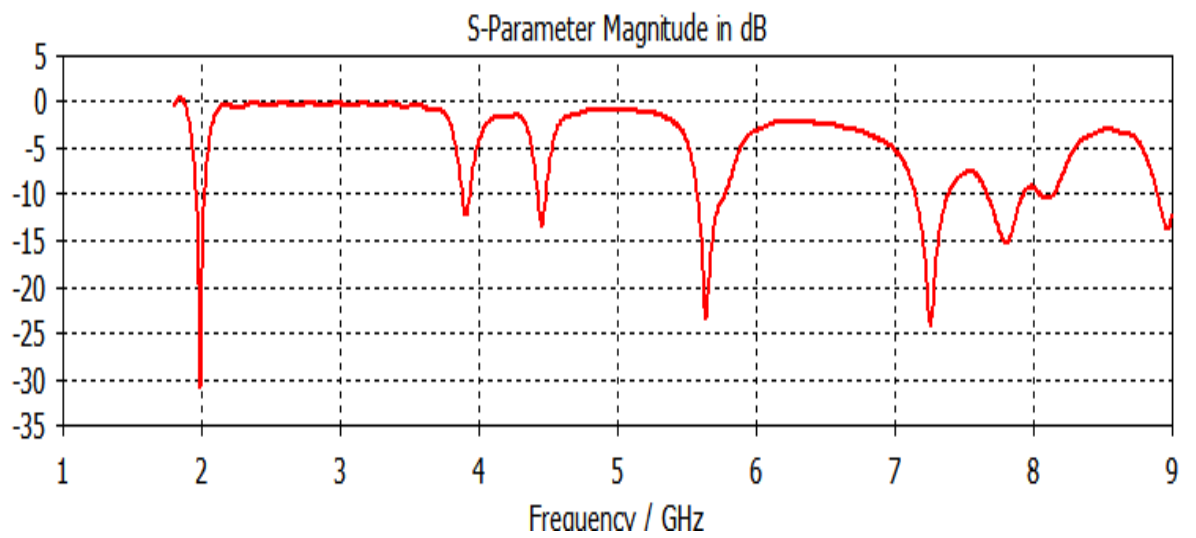

Figure 3.6 S parameter for zero iteration

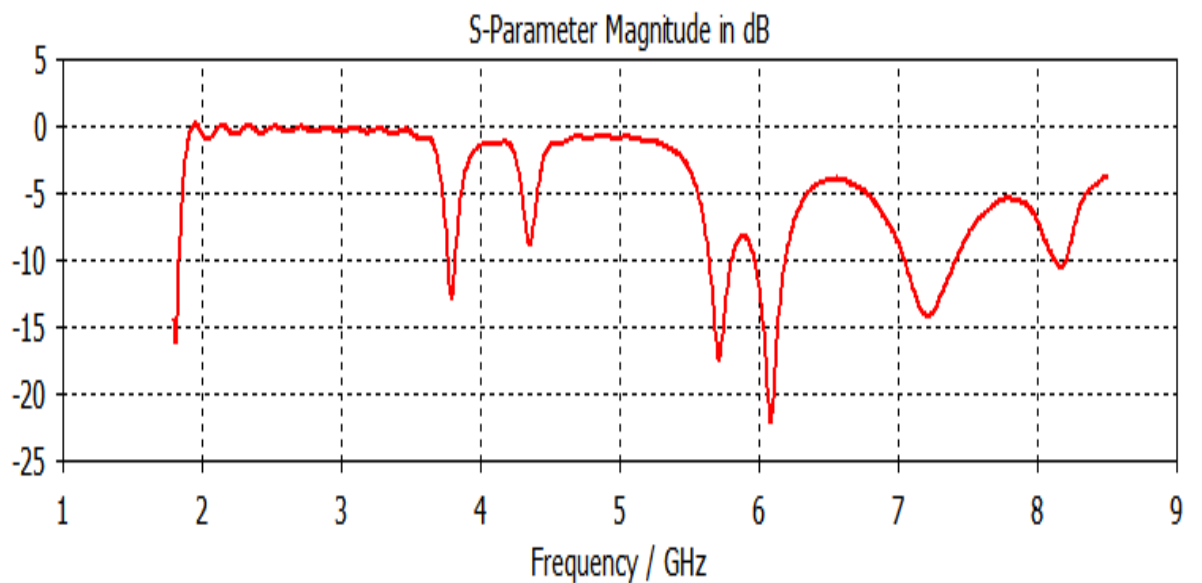

Figure 3.7 S parameter for first iteration

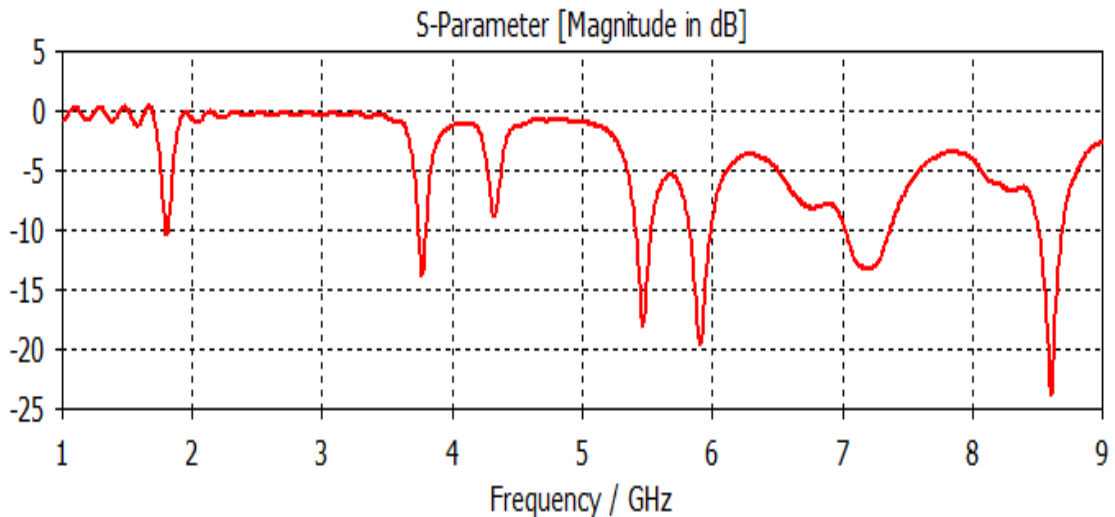

Figure 3.8 S parameter for second iteration

The antenna designed is shown above in figure 3.5. Antenna exhibits a good return loss approximately -24dB at a frequency of 8.608 GHz which is a good result. This antenna resonates at 8.6 GHz frequencies and gives a decent bandwidth of 0.2GHz. The bandwidth is calculated by subtracting lower frequency from the upper frequency at -10dB and it comes out be 8.6 GHz in this specific case.

The proposed antenna design gives good impedance of approximately 50 ohms which shows that the antenna is perfectly matched and the power loss is minimal. The results obtained for the designed antenna is given below.

### 3.6.2 Smith Chart

Markers 1 and 2 show the bandwidth at resonant frequency 8.608 GHz.

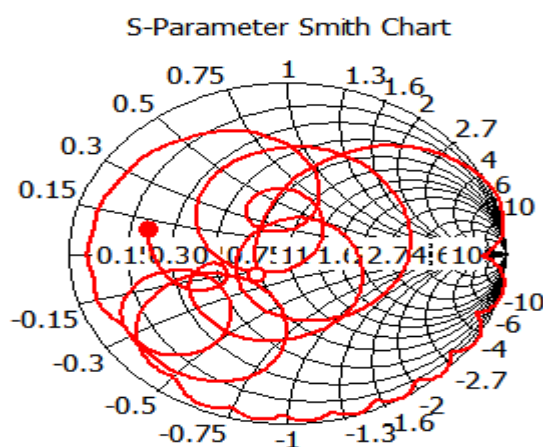

Figure 3.9 Smith Chart for designed antenna

### 3.6.3 Directivity

The simulation results of Directivity in 2D are given below

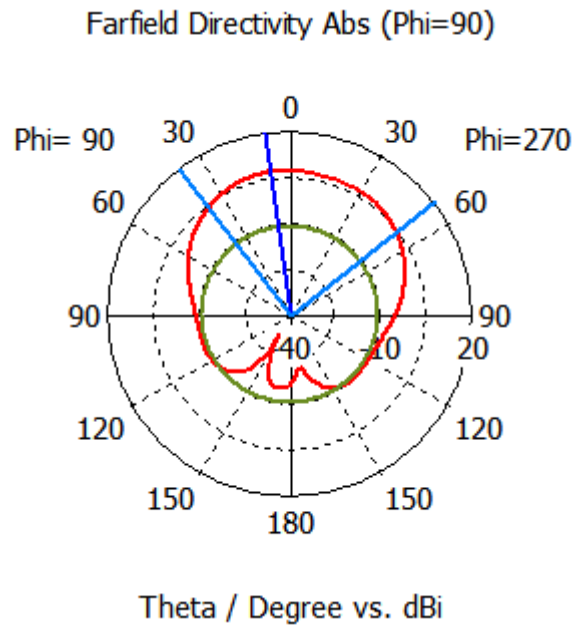

Figure 3.10 Simulated 2D Directivity

### Conclusion

In this chapter we have design wideband antenna for applications at 8.608 GHz and we have achieved wideband antenna which resonates at 8.608 GHz and having bandwidth approximately 0.2 GHz. The Designed Antenna has good impedance and return loss.

Parameters	Value
Operating frequency	8.608GHz
Return loss	-24 GHz
Impedence	50 ohms
Bandwidth	0.2 GHz

Table 3.2 Simulated Results of antenna at 8.608 GHz

## Design of Novel Micro strip Feed Square Triangular Corner Fractal Antenna for UWB Applications

### 4.1 Introduction

The aim of this chapter is to design a square triangular corner Fractal Antenna. In this chapter, square is taken as the initiator. Square and triangle shapes are used at different scales to form square triangular shape geometry. Square triangular shape geometry has been applied to micro-strip patch antenna to reduce its overall size. It can be seen that as the iteration number and iteration factor increases, the resonant frequency decreases which provides the UWB application.

### 4.2 Antenna Design

The dimensions of the square shaped patch used as the initiator is 41.08mm. The radiating square triangular shaped patch is printed on the upper side of the substrate. The substrate is made up of material having dielectric constant 4.4 and height of the substrate is 1.57mm. Feed line is placed between the middle of the patch to the end of the substrate. The width of the feed line is 10mm and the length of 39.41mm from the centre of the micro strip towards the patch axis along the positive Y direction to end. Partial ground plane is used for this antenna design. The following parameters for designed antenna are calculated:

<b>Variables</b>	<b>Values</b>
<b>Width of patch</b>	41.08mm
<b>Length of patch</b>	41.08mm
<b>Width of substrate</b>	90mm
<b>length of substrate</b>	120mm
<b>Height of substrate</b>	1.57mm
<b>Length of ground plane</b>	120mm
<b>Width of ground plane</b>	40mm

Table 4.1 parameters for designed antenna

### 4.3 Dimensions of triple Band Antenna Design

The Figures below shows the simulated antenna design using CST 2014 studio and represents three different iterations.

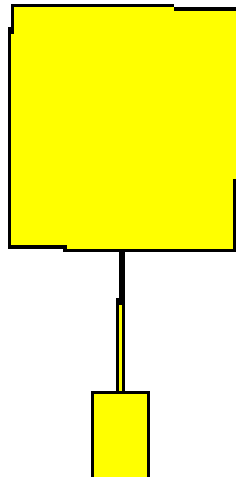

Figure 4.1 Zero iteration

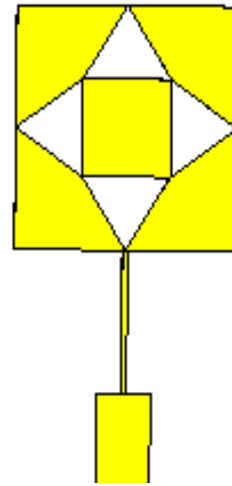

Figure 4.2 First iteration

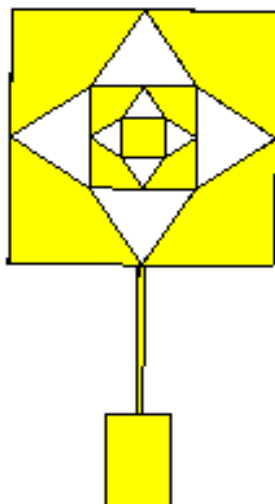

Figure 4.3 Second iteration

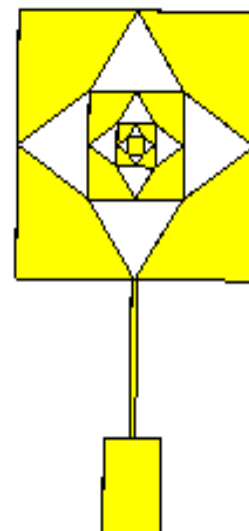

Figure 4.4 third iteration

### 4.3.1 Ground Plane

Ground plane used in the designing of antenna is a modified partial ground plane made up of copper. Ground plane is stretched horizontally. length of the ground plane is 120mm and width 40mm.

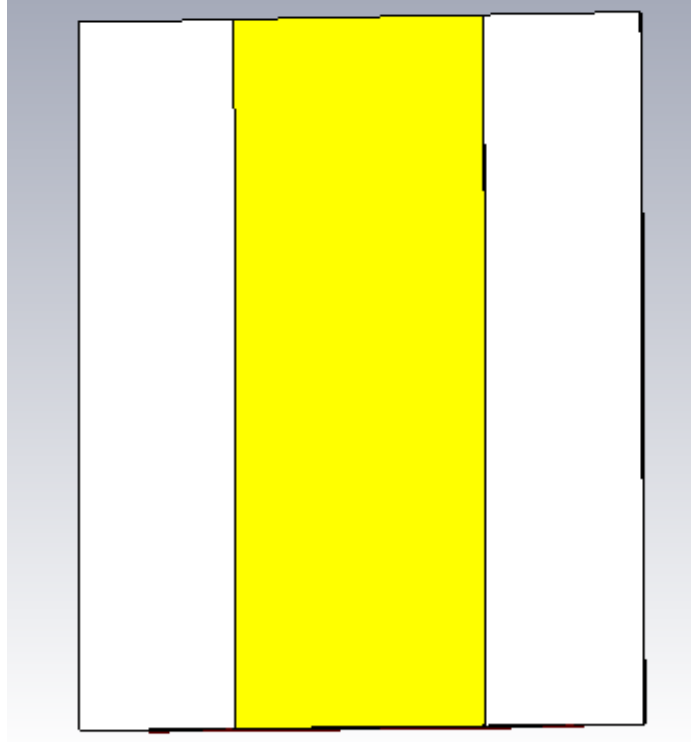

Figure 4.5 Partial ground plane of the stimulated design

## 4.4 Simulation Results

### 4.4.1 Return loss

The return loss (RL) indicates the amount of power which is lost due to the load and is not return as reflection. As already known, waves get reflected which leads in the formation of standing waves when impedance of both the transmitter and antenna do not match. Hence the RL is the parameter similar to VSWR to calculate how well the matching between the transmitter and the antenna has been done. According to results it included that designed antenna resonates at four different frequencies i.e. at 1.95 GHz, 3.6 GHz, 4.8 GHz, and 6.4 GHz respectively and shows application in ultra wide band frequencies .The experiment results of fractal antenna shows ultra wideband characteristics from frequency range of 1.8GHz to 6.5 GHz and thus exhibits a decent bandwidth. The simulated results of the return loss of designed antenna are given in the Figure 4.6 below:

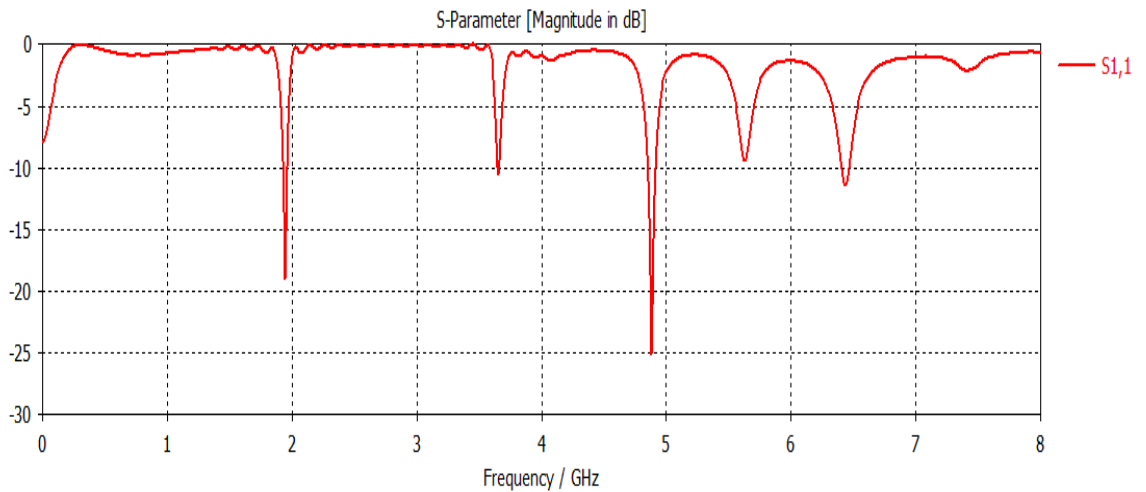

Figure 4.6 Simulated Return losses

The designed antenna resonates at multiple frequencies which are mentioned below with their applications:

- At resonant frequency of 1.95 GHz for personal communication satellites (PCS) Applications.
- At resonant frequency of 3.6 GHz for WiMax and GSM applications.
- At resonant frequency of 4.8 GHz for WLAN (IEEE802.11) applications.
- At resonant frequency of 6.4 GHz for satellite applications.

#### 4.4.2 Directivity

The simulation results of Directivity in 2D are given below:

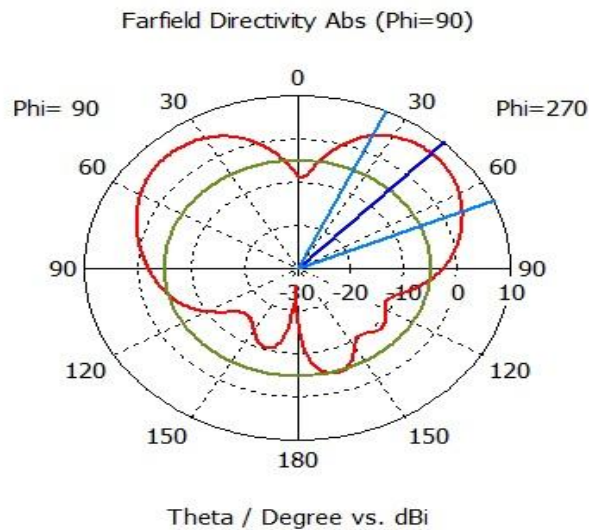

Figure 4.7 Simulated 2D Directivity

## Conclusion

The aim of this chapter was to design and simulate a fractal antenna for UWB applications. The simulated results of the above designed antenna have been calculated and discussed above. It is seen that a Bandwidth of 0.2 GHz, gain of 7.9 dB and return loss of -25dB is obtained for this antenna which proves to be good for UWB applications.

<b>Variables</b>	<b>Values</b>
<b>Operating frequency</b>	4.88 GHz
<b>Return loss</b>	-25 GHz
<b>Impedence</b>	50 ohms
<b>Bandwidth</b>	0.2GHz
<b>Directivity</b>	6.503dB
<b>Gain</b>	5.92dB

Table 4.2 Summary of the Antenna Parameters of Designed Antenna at 4.88 GHz frequency

### 5.1 Introduction

In this chapter, the general procedure for designing of novel micro strip feed crown shaped fractal antenna for WLAN application is presented. Simulated results of this antenna exhibit ultra wideband characteristics from frequency **GHz** to **GHz**. Consequently, this antenna covers the IMT, WLAN, C Band communication satellite and narrowband PCS Service application. It can be seen that as number of iteration increases, resonant frequency lowers which gives WLAN and other applications.

### 5.2 Antenna Design

The final antenna designed with micro strip feed is shown in Figure 4. There are three important parameters for the designing of designed antenna: height of substrate, dielectric material of substrate and resonant frequency. The designed crown monopole antenna is printed on FR-4 Epoxy substrate (dielectric constant 4.4) with substrate thickness of 1.57 mm and length and width of substrate at 120mm and 80mm respectively. The designed antenna is then designed on the substrates by etching rhombus shape on the top of the substrate with length of the rhombus as  $w_1=30\text{mm}$ . This rhombus shaped is called initial iteration or the generator shape. The first iteration of this fractal antenna is designed by adjusting the square shape inside the rhombus which is of same length and dimension as that of the initial rhombus. The square fitted in the first iteration of the designed antenna divide each length of rhombus into equal halves by intersecting at the midpoint of the each side of the rhombus side by the corners of the square. This square dimension is then removed from the rhombus. The 2<sup>nd</sup> iteration is made by fitting the rhombus of length  $w_2$  of 15 mm of side and inscribed square of same side length is removed from this inner rhombus. Further two iteration are done in the same way by scaling down the next iterations at the factor of 2. the same design is the mirror imaged vertically along the x axis by taking same dimensions as before. Feed line is placed at the centre of both patches and ending at the middle of the length of the substrate. Bottom of the substrate is covered with copper ground plane. The following parameter for antenna designed are shown in below Table 5.1

Variables	Value
Dielectrical Material	FR4_EPOXY
Substrate Height	1.57mm
Relative permittivity	4.40
Length of substrate(L)	120mm
Width of substrate (W)	80mm
Length of micro strip feed (Lf)	40mm
Width of micro strip feed (wf)	4mm
Loss tangent	0.009
Side of rhombus w1	30mm
Side of rhombus w2	15mm
Side of rhombus w3	7.5mm
Side of rhombus w4	3.25mm

Table 5.1 parameters for antenna design

### 5.3 Dimensions of designed antenna

The Figure below shows the simulated antenna design using CST 2014 studio with substrate height of 1.57mm and relative permittivity 4.4.

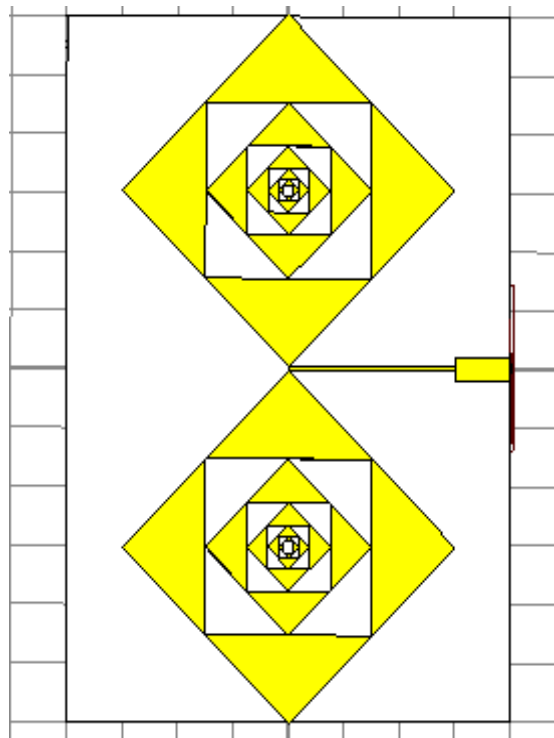

Figure 5.1 Stimulated antenna design

## 5.4 Stimulation results

The simulation results of designed antenna are obtained using CST studio 14.  $S_{11}$  parameter i.e. Return Loss and directivity is calculated.

### 5.4.1 Return loss

The designed fractal antenna is simulated starting from the zero iteration i.e. the generator to fourth iteration. Return loss and directivity is shown in the figure 5.2. The final iteration of designed antenna shows excellent bandwidth from 1.3 GHz to 5.2 GHz and shows multiband behaviour. The simulated results of the return loss and given in the Figure5.2 below:

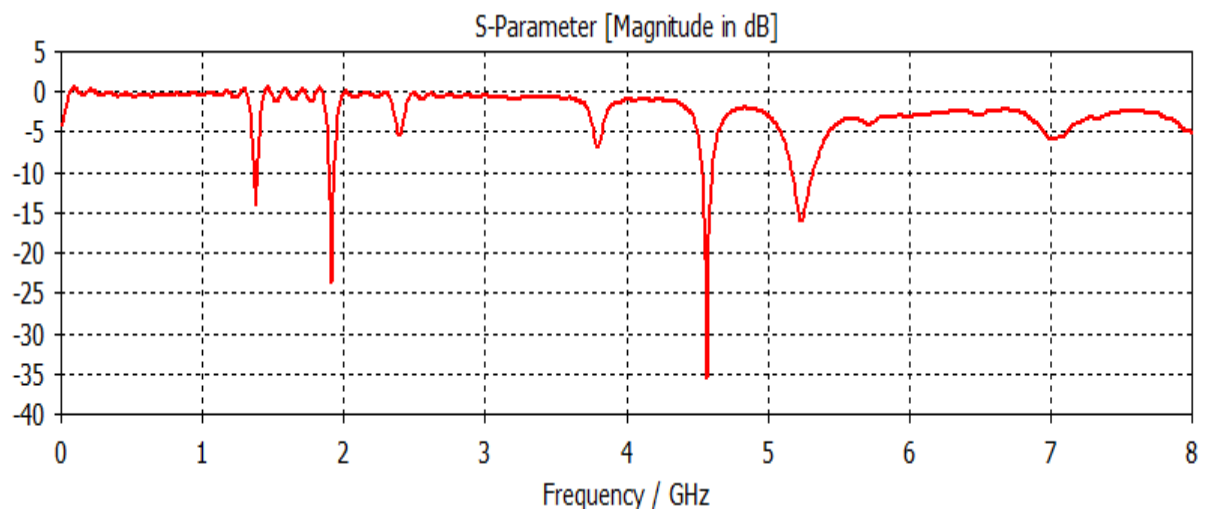

Figure 5.2 S parameter for designed antenna

### 5.4.2 Directivity

The above designed antenna gives a directivity of 4.31dBi at 4.5 GHz frequency.

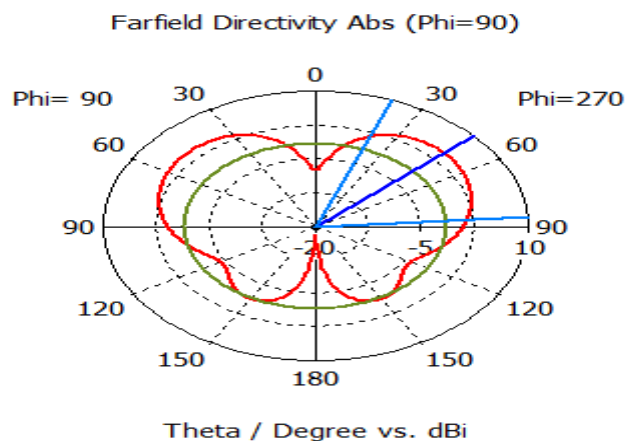

Figure 5.3 2D directivity of designed antenna

## Conclusion

The aim of this chapter was to design and simulate a compact antenna for WLAN applications. The simulated results for various parameters of designed antenna have been discussed above. It is seen that a Bandwidth of 3.24 GHz and Directivity of 4.31 dB is obtained for this antenna which proves that it is good for WLAN applications. The simulated values of parameters show that antenna results are good for practical WLAN and other UWB applications.

<b>Variables</b>	<b>Values</b>
<b>Operating frequency</b>	4.5 dB
<b>Return loss</b>	-35 dB
<b>Impedence</b>	50 ohms
<b>Bandwidth</b>	3.24 GHz
<b>Directivity</b>	4.31 dBi

Table 5.2 Summary of the Antenna Parameters of Designed Antenna at 4.5 GHz frequency

## Fabrication, Testing and Result Discussion of Fractal Antenna

### 6.1 Introduction

In this chapter, fabrication of triple band antenna operating at ultra wide frequency bands has been done. The simulation has been done using CST 2014 software and the fabrication is carried out using PCB fabrication process. The results are measured using VNA.

### 6.2 Simulated Antennas Resonating At 4.88 GHz

By referring to the Section 4.3 and section 4.4 for the Design of an Antenna resonating at 4.88 GHz, we have calculated the following parameters for simulation using CST 2014. The simulated results of the return loss of the antenna design resonating at 4.88 GHz for UWB applications are given below:

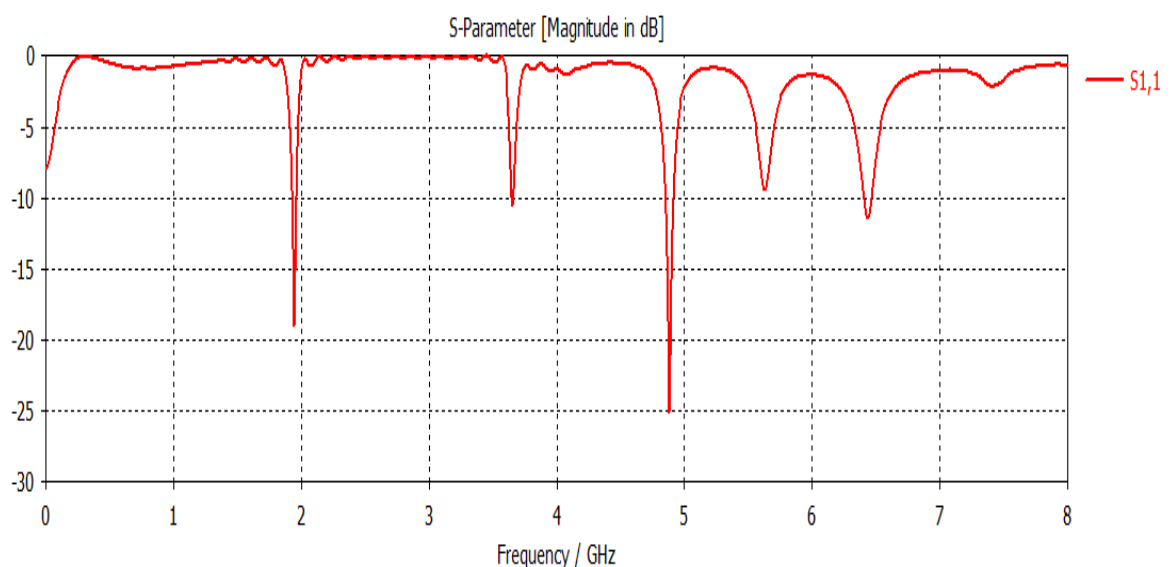

Figure 6.1 S parameter for antenna resonating at 4.88 GHz

### 6.3 Fabrication Process for micro strip patch antenna

In this topic, the whole fabrication procedure of Antenna using novel micro strip Feeding technique is covered. The process of fabrication of the antenna is carried out in few steps which are mentioned briefly in the flow chart which makes it easier to understand the fabrication procedure. The flow chart for the antenna fabrication process is given:

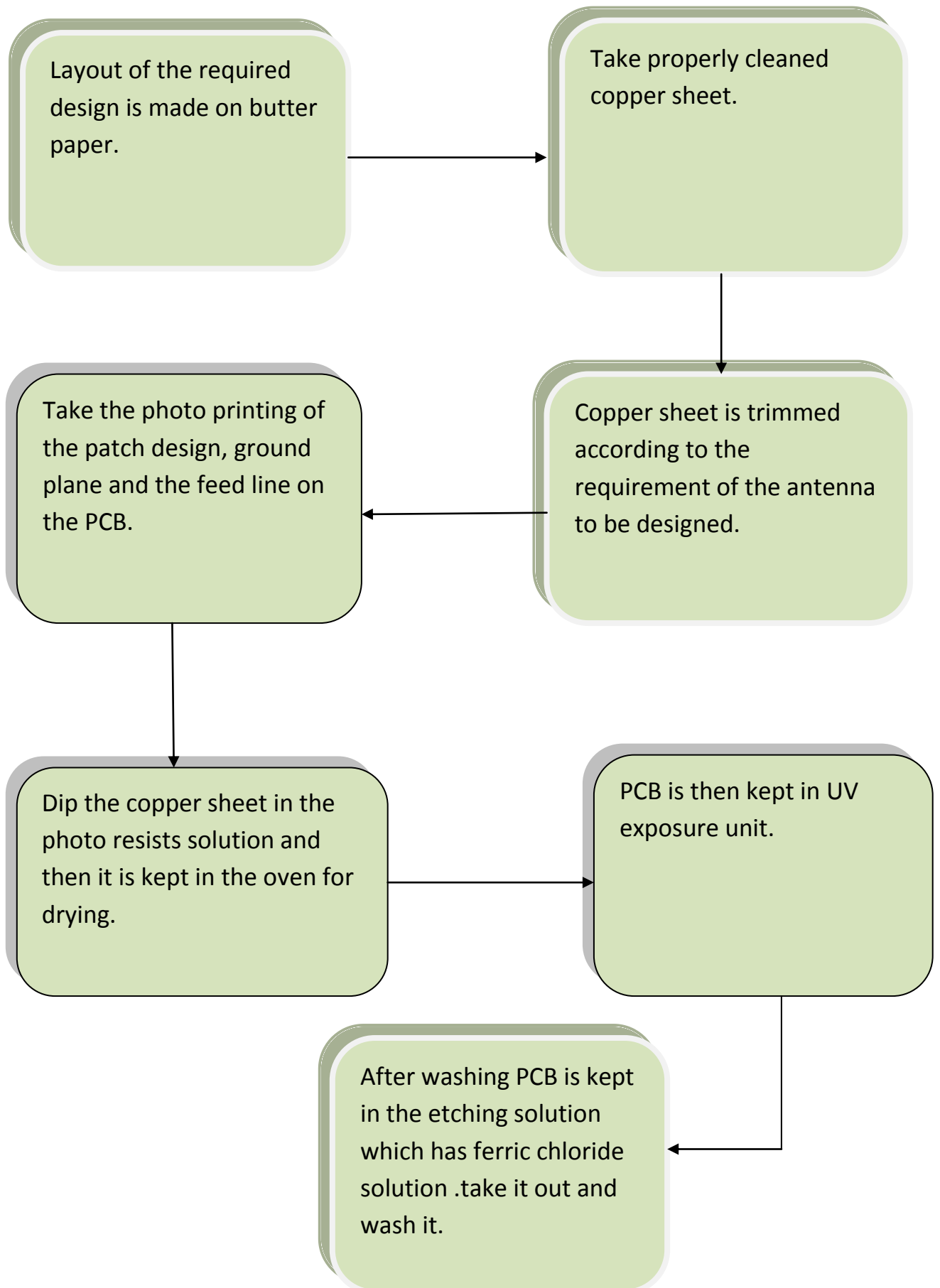

Figure 6.2 Flow chart for process of fabrication of antenna

## 6.4 Fabricated Antenna Design

The fabricated design of the fractal antenna is given in the Figures below:



Figure 6.3 Front view



Figure 6.4 Back view

## 6.5 Testing of Antenna

The testing of antenna can be done by using Network Analyser VNA model no: E5071C, frequency range is 9.5 KHz – 8.5 GHz which analyses one port and two port networks. The Figure below shows the network analyser:



Figure 6.5 Instrument used for testing

## 6.6 Network Analyzer

Network analyzer is used to measure and test different types devices and components. The examples of such the types of devices that can be tested with network analyzers are shown in Figure 6.5. This includes both passive devices and active devices (and some that have characteristics of both). All these devices need to be categorized for both linear and nonlinear behaviour. It is not possible to completely characterize all of these devices with just one piece of test equipment.

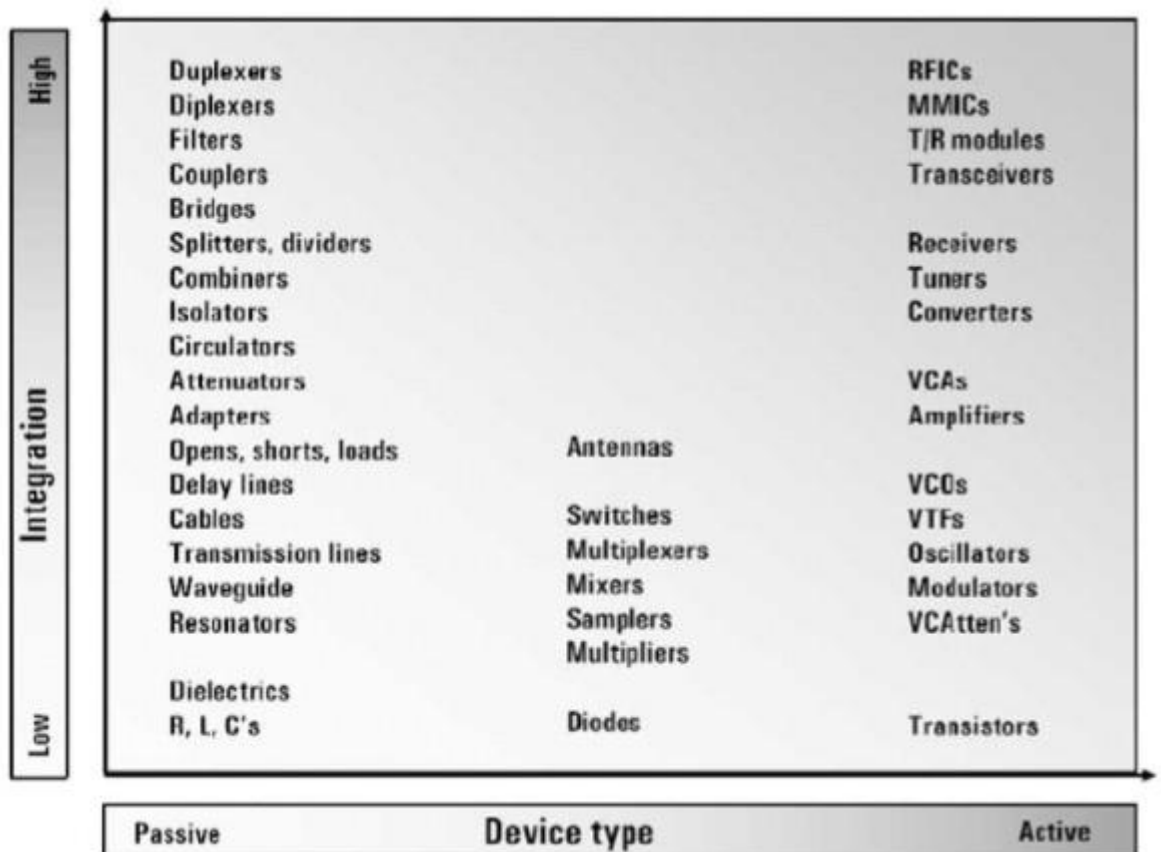

Figure 6.6 Devices that can be tested by a Network Analyzer

Network analyzers are used to measure components, devices, circuits, and subassemblies. They contain source as well as multiple receivers, and generally display ratio of amplitude and phase information (frequency or power sweeps). Though with network analyzers, we do not get the exact and accurate display, but it is very easy to interpret the results. With vector-error correction combined with network analyzers gives much higher accuracy in measurement in comparison to spectrum analyzers.

The generalized block diagram of a network analyzer (figure 6.6), shows the major signal processing sections. For measuring the incident, reflected and transmitted signal, four sections are required:

- 1) Source
- 2) Signal-separation devices
- 3) Receivers to detect the signals
- 4) Processor / display for calculating and displaying the results

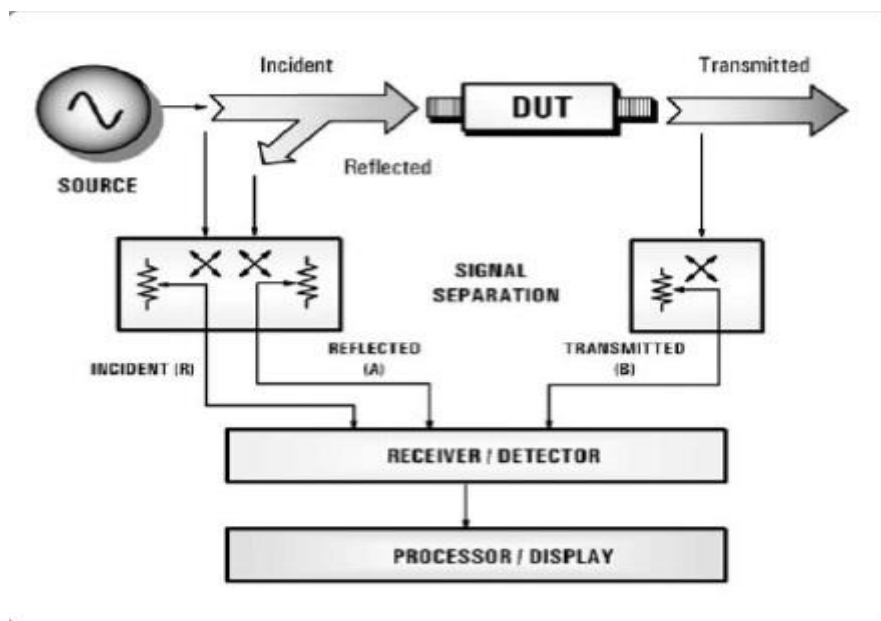

Figure – 6.7 Generalized Block Diagram of a Network Analyzer

## 6.7 Results

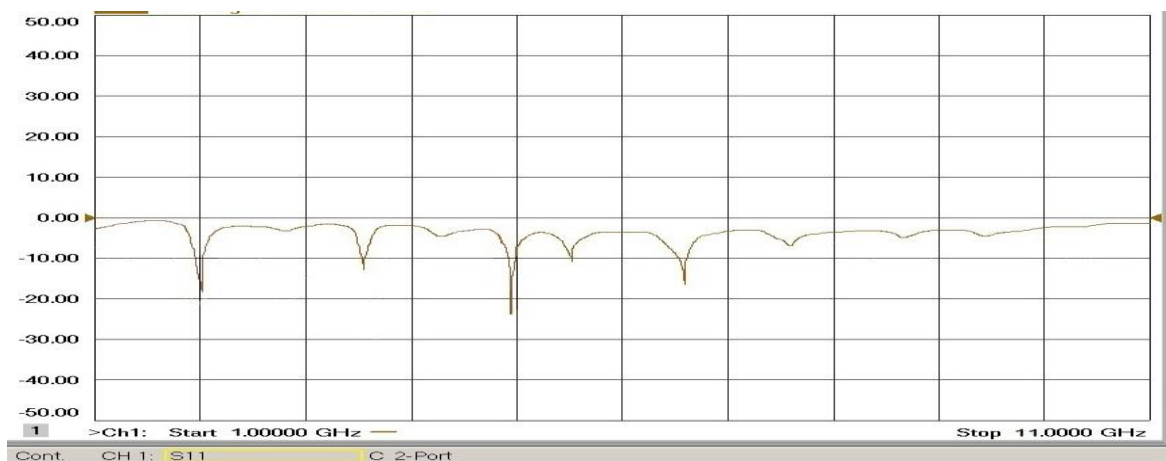

Figure 6.7 Tested results of antenna design

The table below shows the comparison of the simulated and the tested results of the designed antenna and the results are 90% matched.

<b>Parameters</b>	<b>Simulated Results</b>	<b>Tested Results</b>
<b>Return loss</b>	-25dB	-23dB
<b>Resonating Frequency</b>	4.88GHz	4.9GHz

Table 6.1 Tested Results of Antenna Design at 4.88 GHz Frequency

### **Conclusion**

The simulated and tested results are 90% matched; the 10% losses which can be seen are may be due to lose soldering connections, due to presence of air or due to lose SMA connector connections. After these small variations in the results due to some reasons the results are still acceptable.

---

**CONCLUSIONS AND FUTURE SCOPE**

---

**7.1 Conclusion**

The aim of this thesis report is to design antennas with multiband resonance for the applications to cover the recently available communication services. Among the large number of trials, three antenna designs have been designed and their performances are evaluated and found to satisfy the different aspects of the aim of the thesis. These three configurations of Fractal Antenna using micro strip feeding technique are given for ultra wideband applications. The first is the typical design of square sierpinski fractal antenna, the second is the triple band square triangular shaped fractal antenna and the third is the multi-band crown shaped fractal antenna using micro strip feeding technique. Different antenna parameters such as return loss, impedance, VSWR, directivity, gain, bandwidth and operating frequency are studied for antenna designing. The effect of physical values on the antenna parameters are also observed in this thesis.

Thesis initially introduces to fractal antenna and describes various parameters and measures of fractal antenna which proceeds with study of literature survey and work done until today. Literature survey is then concluded with the gaps in research of fractal antenna

**Chapter 3** presents the designing of the square sierpinski shaped Fractal Antenna operating at 8.6 GHz for WLAN applications. Thus efficient results are obtained from the designed sierpinski Antenna. The results gives return loss of approximately -24 dB and band width of 0.2 GHz. The antenna has various applications in mobile phones, electronic devices like microwave ovens, satellite communication etc.

**Chapter 4** contains a triple band square triangular shaped fractal antenna is designed using novel micro strip feeding technique. Triangular-shaped slot on the patch helps in optimizing and improving the results. The designed antenna resonates at 4.8 GHz. The proposed antenna can be used for various applications like personal communication satellites (PCS), WiMax and GSM applications, WLAN, satellite applications.

**Chapter 5** represents the multi band antenna for applications of ultra wideband. The crown shaped patch helps in improving the results, bandwidth and gives the multiple

bands. The patch length, width and the position of the patch are varied in order to obtain the optimized results of the antenna. The designed antenna efficiently resonates at 1.4GHz, 1.8GHz, 4.5GHz and 5.2GHz and gives the optimized results.

It can also be seen that physical parameters like width, length of patch and feed line width etc. effects in the results of the antenna. It can be observed that on varying these parameters in the right manner optimized results can be obtained for a desired resonant frequency operation.

The results of the designed antennas are summarized in the following table:

<b>Parameters</b>	<b>Sierpinski square fractal antenna</b>	<b>Square triangular shaped fractal antenna</b>	<b>Crown shaped fractal antenna</b>
<b>Operating frequency</b>	8.6GHz	4.8GHz	4.5GHz
<b>Return loss</b>	-24dB	-25dB	-35dB
<b>Impedence</b>	50 ohms	50 ohms	50 ohms
<b>Bandwidth</b>	0.2GHz	0.2GHz	0.33GHz
<b>Feeding technique</b>	Micro strip feed line	Micro strip feed line	Micro strip feed line

Table 7.1 Comparison of all designed Antenna Parameters Values

## 7.2 Future Scope

Since fractal antenna engineering research is still in its starting stage, there are many possibilities of further research work in this work. However, many possible fractal structures exist that shows desirable properties. Thus, a possible approach for future work in fractal engineering is to investigate other types of fractals for antenna applications. A novel development is the designing of antenna arrays using fractal structure. Fractal antennas can be studied in different areas. One of which is development in implement of fractal antennas for current requirements and technologies in practical situations such as expanding wireless market. For this application an analysis of the polarization of these antennas will need to be looked.

Another benefit that can be explored is lower covered area of resonant loop antennas. This may lead to antenna with lower cross sections. Also, fractals can be used as micro strip antennas designing of Wideband antenna using Sierpinski gasket has been shown to have decent bandwidth. However currently it is limited to microwave frequencies only. If it can be reduced to VHF/UHF bands, a large number of potential applications arise. However this requires more flexibility in choosing material systems. But in some cases improvement in bandwidth causes decrease in antenna efficiency, calling for a compromise between the two. Antenna size miniaturization is obtained due to iterating property of fractal geometries which is often related with low input resistance. Although this can be improved by changing the location of antenna feed accordingly, though the radiation efficiency of the antenna does not improves. Hence for implementing this approach practically, it may require the employ of different fractal geometries. It would be of interest to have an integrated design approach whereby, given the specifications of antenna performance, a suitable geometry and its dimensions are determined. In this work, the fractal dimension is identified as important factor in influencing antenna characteristics. Though it may not be the only factor. Another important advantage of fractal geometries are their repetitive nature. Several difficult calculations can possibly be done by making use of fractal nature of the antenna into the formulation. Extensive design optimization was necessary if antenna configuration was to be synthesizing for a particular radiation design.

Still there is enough scope for improvement and further research. Some such works are briefly mentioned below.

Other fractal geometries like V-Koch, Hilbert curve, Sierpinski gasket and Multi-band fractal antenna can be used for designing of fractal antennas. Sierpinski antenna with micro strip feed can be optimised by changing the shape of ground plane rather than just perturbing the geometry itself.

A novel CPW feed Sierpinski carpet antenna can be designed, simulated and compared. Stacked fractal antenna Engineering is another area that can be explored and worked upon future. Fractal antennas using Meta materials could be designed.

Meta-materials: A meta-material is a metallic or semiconductor substance whose properties depend on its inter-atomic structure rather than on the composition of the

atoms themselves. Certain meta-materials can bend visible light rays in the opposite sense from traditional refractive media. Some meta-materials can also exhibit behaviour at infrared (IR) wavelengths. Possible applications of transparent meta-materials with negative indices of refraction include red and IR lasers, optical communications systems, spectrometry, monitoring systems to detect trace gases in the atmosphere, medical diagnostic equipment and optical cloaking devices. In meta-materials both  $\epsilon_r$  and  $\mu_r$  are negative.

The work on done on fractal antenna design using micro strip feed can be extended to:

- Using different structure designs, the use of different dielectric substrate material as well as combination of substrates in one structure.
- Using different slots designs on the patch and the ground, the use of different shape of patch with larger radiating area.
- Using impedance matching network so that impedance bandwidth could be improved.

Other Feeding Techniques: The other feeding techniques of fractal antenna like coaxial feeding, aperture coupling and CPW can also be used to design the same fractal antennas.

- [1] Andrea goldsmith, "wireless communication", *Cambridge university press*, 2005
- [2] Al-Mously, S.I.; Abousetta, M.M., "A Novel Multi-Wideband Antenna Using a 3-D Multi-Branch Monopole Structure for GSM-Family and Other Cellular Applications," *Telecommunications in Modern Satellite, Cable and Broadcasting Services, 2007. TELSIKS 2007. 8th International Conference on*, vol., no., pp.577, 580, 26-28 Sept. 2007
- [3] Kishk, A.A.; Xuan Hui Wu; Ryu, K.S., "UWB antenna for wireless communication and detection applications," *Ultra-Wideband (ICUWB), 2012 IEEE International Conference on*, vol., no., pp.72, 76, 17-20 Sept. 2012
- [4] H. Y. Lai, Z. Y. Lei, Y. J. Xie, G. L. Ning, and K. Yang, "UWB Antenna With Dual Band Rejection For WLAN/WIMAX Bands Using CSRRs," *Progress in Electromagnetic Research Letters*, Vol. 26, pp. 69 - 78, 2011.
- [5] Badamchi, Nourinia, Ghobadi and V. Shahmirzadi, "Design of compact reconfigurable ultra-wideband slot antenna with switchable single/dual band notch functions," *IET Microwaves, Antennas & Propagation*, Vol. 8, Issue 8, pp. 541 - 548, 2014.
- [6] B. B. Mandelbrot, "The Fractal Geometry of Nature" *W.H Freeman and Company, 1983*.
- [7] D. H. Werner and S. Ganguly, "An Overview of Fractal Antenna Engineering Research," *IEEE Antennas and Propagation Magazine*, vol.45, no.1, pp.38-57, February 2003.
- [8] J. P. Gianvittorio, *Fractals, MEMS, and FSS Electromagnetic Devices: Miniaturization and Multiple Resonances*, PhD Thesis, *University of California*, 2003
- [9] Vinoy, K.J.; Abraham, J.K.; Varadan, V.K., "Fractal dimension and frequency response of fractal shaped antennas," *Antennas and Propagation Society*

*International Symposium, 2003. IEEE, vol.4, no., pp.222, 225 vol.4, 22-27 June 2003*

- [10] A. Tiwariissn, "Fractal Applications in Electrical and Electronics Engineering," *IJESAT, Vol. 2, Issue 3, pp. 406 – 411, 2012.*
- [11] S. Lin, T. Li and X. Tang, "Achieving Low-Power Consumption by Using Fractal Coding in PVP," *Proceedings of the 2007 IEEE International Conference on Mechatronics and Automation.*
- [12] Petko, J.S.; Werner, D.H., "The autopolyploidy enhanced evolution of large-N fractal-random arrays," *Radar Conference, 2005 IEEE International, vol., no., pp.922, 926, 9-12 May 2005*
- [13] Jampala, S., "Fractals: classification, generation and applications," *Circuits and Systems, 1992., Proceedings of the 35th Midwest Symposium on , vol., no., pp.1024,1027 vol.2, 9-12 Aug 1992*
- [14] J. Feder, "Fractals", *Plenum Press, New York 1988*
- [15] Tewfik, A.H.; Deriche, M., "Maximum likelihood estimation of the fractal dimensions of stochastic fractals and Cramer-Rao bounds," *Acoustics, Speech, and Signal Processing, 1991. ICASSP-91., 1991 International Conference on , vol., no., pp.3381,3384 vol.5, 14-17 Apr 1991*
- [16] T. Rappaport, *Wireless Communications: Principles & Practice, second edition Prentice-Hall, 2002.*
- [17] D. H. Werner, "An Overview of Fractal Electrodynamics Research," *Proceedings of the 11<sup>th</sup> Annual Review of Progress in Applied Computational Electromagnetic (ACES) Vol. 11, pp. 964-969, March 1995,*
- [18] Kravchenko F. and A.A. Potapov, 2001 "New class of Atomic fractal functions & their applications", *Physics and Engineering of millimeter and Sub Millimeter Waves, vol.1, pp.102-107.*

- [19] Gianvittorio, J.P.; Rahmat-Samii, Y., "Fractal antennas: a novel antenna miniaturization technique, and applications," *Antennas and Propagation Magazine, IEEE*, vol.44, no.1, pp.20, 36, Feb 2002.
- [20] H. O. Peitgen, H. Jurgens, and D.Saupe, "Chaos and Fractals: New Frontiers of Science," New York, *Springer-Verlag, Inc.*, 1992.
- [21] S. E. El-Khamy, M. A. Aboul-Dahab, and M. I. Elkashlan, "A Simplified Koch Multiband Fractal Array Using Windowing and Quantization Techniques," *IEEE International Symposium on Antennas and Propagation Digest, Volume 3*, Salt Lake City, Utah, July2000, pp. 1716-1719
- [22] Y. Kim, D. L. Jaggard, "The fractal random array," *Proceedings of the IEEE* , vol.74, no.9, pp.1278,1280, Sept. 1986
- [23] N. Cohen, "Fractal Antennas: Part 2," *Communications Quarterly, summer*, 1995, pp.53-66.
- [24] C. P. Baliarda, R. Pous, "Fractal design of multiband and low side-lobe arrays," *IEEE Transactions on Antennas and Propagation*, vol.44, no.5, pp.730-746, May 1996.
- [25] N. Cohen, "Fractal Antenna Applications in Wireless Telecommunications," *Proceedings of the Electronics industries Forum of New England, 1997*, pp. 43-49.
- [26] R. G. Hohlfeld and N. Cohen, "Self-Similarity and the Geometric Requirements for Frequency Independence in Antennae," *Fractals*, 7, I, March 1999, pp. 79-84.
- [27] C. Puente, L. Romeu, R. POUS, and A. Cardania, "On the Behaviour of the Sierpinski Multiband Fractal Antenna," *IEEE Transactions on Antennas and Propagation*, pp. 517-524, April 1998.
- [28] C. P. Baliarda, C. B. Borau, M. N. Rodero, and J. R. Robert, "An iterative model for fractal antennas: application to the Sierpinski gasket antenna," *IEEE Transactions on Antennas and Propagation*, vol.48, no.5, pp.713-719, May 2000.

- [29] J. Romeu, J. Soler, "Generalized Sierpinski fractal multiband antenna," *IEEE Transactions on Antennas and Propagation*, vol.49, no.8, pp.1237-1239, Aug 2001.
- [30] J. Soler, J. Romeu, "Dual-band Sierpinski fractal monopole antenna," *IEEE Society International Symposium Antennas and Propagation*, vol.3, pp.1712-1715, July 2000.
- [31] C. Puente, M. Navarro, J. Romeu, and R. Pous, "Variations on the Fractal Sierpinski Antenna Flare Angle," *IEEE International Symposium on Antennas and Propagation Digest*, Vol. 4, Atlanta, Georgia, pp. 2340-2343, June 1998.
- [32] Puente, C.; Romeu, J.; Pous, R., "Multiband properties of a fractal tree antenna generated by electrochemical deposition," *Electronics Letters*, vol.32, no.25, pp.2298, 2299, 5 Dec 1996.
- [33] M. Sindou, G. Ablart, and C. Sourdois, "Multiband and wideband properties of printed fractal branched antennas," *IEE Electron. Lett.* vol. 35, no. 3, pp. 181–182, Feb. 1999.
- [34] D. H. Werner, A.R. Bretones, B. R. Long, "Radiation characteristics of thin-wire ternary fractal trees," *Electronics Letters*, vol.35, no.8, pp.609-610, 15 Apr 1999.
- [35] J. S. Petko, and D. H. Werner, "Dense 3D fractal tree structures as miniature end-loaded dipole antennas," *IEEE Society International Symposium Antennas and Propagation*, vol.4, pp.94-97, 2002.
- [36] J. S. Petko, and D. H. Werner, "Miniature reconfigurable three-dimensional fractal tree antennas," *IEEE Transactions on Antennas and Propagation*, vol.52, no.8, pp.1945-1956, Aug. 2004.
- [37] K. J. Vinoy, K. A. Jose and V. K. Varadan, "Hilbert curve fractal antennas with reconfigurable characteristics," *IEEE MTT-S International Microwave Symposium Digest*, vol.1, pp. 381-384, May 2001.

- [38] J. Anguera, C. Puente, J. Soler, "Miniature monopole antenna based on the fractal Hilbert curve," *IEEE Society International Symposium Antennas and Propagation*, vol.4, pp. 546-549, 2002.
- [39] X. Yang, B. Wang and Y. Zhang, "Reconfigurable Hilbert curve patch antenna," *IEEE International Workshop on Antenna Technology, Small Antennas and Novel Metamaterial*, vol. 6, pp. 521-524, March 2005.
- [40] N. Prombutr, P. Akkaraekthalin, "Model of Hilbert Curve Fractal Antenna Fed by Coplanar Waveguide for Multi-band Wireless Communications," *Asia-Pacific APMC Microwave Conference*, pp. 1-4, Dec. 2007.
- [41] J. Romeu, C. Borja, S. Blanch, and I. Girona, "High Directivity Modes in the Koch Island Fractal Patch Antenna," *IEEE International Symposium on Antennas and Propagation Digest*, Vol. 3, pp. 1696-1699, Salt Lake City, Utah, July 2000,
- [42] Zhengwei Du; Ke Gong; Fu, J.S.; Baoxin Gao, "Analysis of microstrip fractal patch antenna for multi-band communication [by FDTD]," *Electronics Letters*, vol.37, no.13, pp.805, 806, 21 Jun 2001
- [43] L. Ying, G. Shu-xi and F. De-min, "Micro strip fractal patch antenna for multi-band communication," *International Conference on ICMMT Microwave and Millimetre Wave Technology*, vol. 3, pp. 600-602, Aug. 2002.
- [44] J. Anguera, C. Puente, C. Borja and R. Montero, "Bowtie microstrip patch antenna based on the Sierpinski fractal," *IEEE Society International Symposium Antennas and Propagation*, vol.3, pp. 162-165, July 2001
- [45] N. Rao, K. V. Dinesh, "Gain enhancement of microstrip patch antenna for Wi-Fi applications," *Antennas and Propagation Conference (LAPC), Loughborough*, pp. 312-315, Nov. 2014.
- [46] Kim, Y.; Jaggard, D.L., "The fractal random array," *Proceedings of the IEEE*, vol.74, no.9, pp.1278,1280, Sept. 1986

- [47] J. S. Petko, D. H. Werner, "Progressive evolution of fractal random arrays by generator mitosis," *IEEE Antennas and Propagation Society International Symposium*, vol.3, pp. 2305-2308, June 2004.
- [48] J. S. Petko, D. H. Werner, "Interleaved Ultrawideband Antenna Arrays Based on Optimized Polyfractal Tree Structures," *IEEE Transactions on Antennas and Propagation*, vol. 57, no.9, pp. 2622-2632, Sept. 2009
- [49] C. Eldervitch, G. D'Assuncao, C. R. M. Silva, "Optimization of the input impedance of Koch triangular quasi-fractal antennas using genetic algorithms," *IEEE Conference on Electromagnetic Field Computation (CEFC)*, pp. 1-6, May 2010.
- [50] C. A. Balanis, "Antenna Theory: Analysis and Design", third Edition, *John Wiley & Sons*
- [51] G. Kumar, and K. P. Ray, "Broadband Micro strip Antennas", *Artech House, Inc., Boston, London*