

# **EFFICIENCY ENHANCEMENT OF MICROWAVE OVEN**

A Dissertation submitted in fulfillment of the requirements for the Degree  
of

## **MASTER OF ENGINEERING** *in* **Power Systems**

*Submitted by*

Ankur Singhal  
(Reg. No. 801742005)

*Under the Guidance of*

**Dr. Parag Nijhawan**  
Associate Professor  
EIED  
TIET, Patiala

**Dr. Amrita Sinha**  
Assistant Professor  
EIED  
TIET, Patiala

**Mr. Kamlesh Rai**  
Manager  
R&D, LGEIL  
Greater Noida



**THAPAR INSTITUTE**  
OF ENGINEERING & TECHNOLOGY  
(Deemed to be University)

**2019**

**Electrical and Instrumentation Engineering Department**  
**Thapar Institute of Engineering & Technology, Patiala**  
*(Declared as Deemed-to-be-University u/s 3 of the UGC Act., 1956)*  
**Post Bag No. 32, Patiala – 147004**  
**Punjab (India)**

**LG Electronics India Pvt. Ltd.**

Plot No. 51, Udyog Vihar, Surajpur-Kasna Road, Greater Noida - 201306(U.P.) India  
T: 91 - 120-2560 900/40 F: 91 - 120-2560 921/26 Website: [www.lgindia.com](http://www.lgindia.com)

*Certificate of Internship - 2019*

*This is to certify that*

**Mr. ANKUR SINGHAL**

**A student of THAPAR UNIVERSITY, PATIALA  
has undergone his internship in our Organisation.**

**Duration:- 17 dec 18 to 21 jun 19**

**Work Area:- Development Deptt in MFG.**

**Project Title:- EFFICIENCY ENHANCEMENT OF MICROWAVE OVEN**

**We wish him Success in all his Future Endeavours.**

**For L.G. Electronics :**

**NEERAJ KUMAR SINGH  
HR & MS**

**Since this is a system generated mail hence does not require any signature.**

# DECLARATION

I hereby certify that the work which is presented in dissertation entitled, "**EFFICIENCY ENHANCEMENT OF MICROWAVE OVEN**", in partial fulfillment of the requirements for the award of the degree of Master of Engineering in Power Systems, submitted to Electrical & Instrumentation Engineering Department of Thapar Institute of Engineering & Technology (Deemed to be University) is as authentic record of my own work carried under the supervision of Dr. Parag Nijhawan, Dr. Amrita Sinha & Mr. Kamlesh Rai. It refers others researcher's work which are duly listed in the reference section. The matter contained in this dissertation has not been submitted, neither in part nor in full to any other degree to any other university or institute except as reported in text and references.

Place: Patiala  
Date: 20/08/19

  
**Ankur Singhal**  
Roll No.: 801742005

It is certified that the above statement made by the student is correct to the best of my knowledge and belief.

Date:

  
**Dr. Parag Nijhawan**  
Associate Professor  
EIED  
TIET, Patiala

  
**Dr. Amrita Sinha**  
Assistant Professor  
EIED  
TIET, Patiala

  
**Mr. Kamlesh Rai**  
Manager  
R&D, LGEIL  
Greater Noida

# ACKNOWLEDGEMENT

I would like to express my profound exaltation and gratitude to my industry mentor Mr. Kamlesh Rai (Manager), LG Electronics R&D, Greater Noida and faculty mentor Dr. Parag Nijhawan (Associate Professor) & Dr. Amrita Sinha (Assistant Professor), EIED, TIET, Patiala for their candid guidance, constructive propositions and overwhelming inspiration in the nurturing work. It has been a blessing for me to spend many opportune moments under the guidance of the perfectionist at the pinnacle of professionalism. The present work is the testimony to their activity, inspiration and ardent personal interest, taken by them during the course of his work in its present form.

I am also thankful to Dr. R.S. Kaler (Professor & Head) and Ms. Manbir Kaur (Associate Professor), EIED for his assistance and support.

I would like to express my gratitude to Mr. Manjeet Chawla (DGM), Team Leader of MWO R&D, for his guidance and providing facilities in successful completion of this work. I thank to all those who have contributed directly or indirectly to this work.

Finally, I must express my very profound gratitude to my parents for providing me with unfailing support and continuous encouragement throughout my years of study and through the process of researching and writing this thesis.

  
Ankur Singhal  
(801742005)

# TABLE OF CONTENTS

	<b>Page</b>
<b>DECLARATION</b>	i
<b>ACKNOWLEDGEMENT</b>	ii
<b>LIST OF TABLES</b>	v
<b>LIST OF FIGURES</b>	vi
<b>LIST OF SYMBOLS</b>	viii
<b>LIST OF ABBREVIATIONS</b>	x
<b>ABSTRACT</b>	xi
<b>CHAPTER-1 INTRODUCTION</b>	<b>1-3</b>
1.1 Introduction	1
1.2 Need Analysis	2
1.3 Aim and Objectives of Thesis	3
1.4 Organisation of Thesis	3
<b>CHAPTER - 2 LITERATURE SURVEY AND PROBLEM FORMULATION</b>	<b>4-12</b>
2.1 Earlier Works – An Overview	4
2.2 Gap of Study	11
2.3 Formulation of Objectives	11
2.4 Expected Deliverables	11
2.5 Novelty of Work	12
<b>CHAPTER - 3 THEORY, STANDARD AND CONSTRAINT</b>	<b>13-37</b>
3.1 Microwave Oven	13
3.2 Brief History of Microwave Oven	13
3.3 Components of Microwave Oven	14
3.3.1 High Voltage Transformer	14
3.3.2 Voltage-Doubler Circuit	15
3.3.3 Magnetron	16
3.3.4 Waveguide	17
3.3.5 High Voltage Fuse	17
3.3.6 Cooling Fan	17
3.3.7 Plug and Power Cord	18

3.3.8	Thermostat	18
3.3.9	Bulb Holder and Bulb	18
3.3.10	Turntable Plate and Turntable Motor	19
3.4	Magnetrons	19
3.4.1	Magnetron History	20
3.4.2	Structure of Magnetron	21
3.4.3	Cylindrical Magnetron Operation	24
3.4.4	Magnetron Applications	31
3.5	CST Particle Studio	33
3.5.1	Particle-In-Cell Simulation Technique	34
3.6	HV Supply for Microwave Generator	35
3.6.1	Modelling of The Nonlinear Inductances	36
<b>CHAPTER – 4</b>	<b>TEST ON MICROWAVE OVEN AS PER IEC 60705</b>	<b>38-40</b>
4.1	Determination of Microwave Power Output	38
4.4.1	General Test Condition	38
4.1.2	Test Method	38
<b>CHAPTER – 5</b>	<b>DESIGN METHODOLOGY</b>	<b>41-46</b>
5.1	Proposed Work Flow/ Methodology	41
<b>CHAPTER – 6</b>	<b>RESULT AND DISCUSSION</b>	<b>47-52</b>
6.1	Simulation Results	47
6.2	Discussions/ Inferences Drawn	51
<b>CHAPTER – 7</b>	<b>CONCLUSION AND FUTURE WORK</b>	<b>53-53</b>
7.1	Conclusion	53
7.2	Future Work	53
	<b>LIST OF PUBLICATIONS</b>	<b>54</b>
	<b>REFERENCES</b>	<b>55</b>

# LIST OF TABLES

<b>Table No.</b>	<b>Caption</b>	<b>Page</b>
Table 5.1	HVT Parameters	45
Table 5.2	Voltage Doubler Circuit	46
Table 5.3	Microwave Generator Parameters	46
Table 6.1	MGT Input Parameters Values	51
Table 6.2	Performance of the MWO with Different Cases	51

# LIST OF FIGURES

Figure No.	Caption	Page
Figure 1.1	Range of Microwaves	1
Figure 3.1	Block Diagram of Microwave Oven	13
Figure 3.2	Radarrange Developed Microwave Oven	14
Figure 3.3	High Voltage Transformer and High Voltage Fuse	15
Figure 3.4	Schematic Diagram of a Voltage-Doubler Circuit	15
Figure 3.5	High Voltage Capacitor and a Diode Used in a Microwave Oven Assembly	15
Figure 3.6	Structure of a magnetron and its sub-assemblies	16
Figure 3.7	Waveguide in The Microwave Oven	17
Figure 3.8	Cooling Fan Mounted to a Microwave Chassis	18
Figure 3.9	Electrical Plug and Power Cord	18
Figure 3.10	Thermostat in Microwave Oven	18
Figure 3.11	Bulb and Bulb Holder Assembly	19
Figure 3.12	Turntable Motor and Plate in Microwave Oven	19
Figure 3.13	Types of Magnetrons	20
Figure 3.14	Magnetron Design model Used in Microwave Oven	22
Figure 3.15	Different Types of Cavities Used in Magnetron	23
Figure 3.16	Schematic Diagram of a Cylindrical Magnetron	24
Figure 3.17	Electron's Path Under Lorentz Force	25
Figure 3.18	Setup of Electron Cloud in Case of Magnetron	25
Figure 3.19	Interaction of Electron and RF Field in the Cathode and Anode Gap	26
Figure 3.20	Electron Spokes	26
Figure 3.21	Path of Electron According to Various Magnetic Fields	27
Figure 3.22	Diagram of Hartree Threshold Voltage in Case of 8 Cavity Magnetron	29
Figure 3.23	Electrical Equivalent Circuit in Case of 8 Cavity Magnetron	29
Figure 3.24	Dispersion Diagram Representing 8 Cavity Magnetron	30
Figure 3.25	Lines of Force For 8 Cavity Magnetron in $\pi$ -Mode	31
Figure 3.26	Magnetron With $\pi$ -Mode (At Right Side) And $2\pi$ -Mode (At Left Side)	34
Figure 3.27	6- Coupled Cavity Electron Spoke in $\pi$ -Mode	35

Figure 3.28	High Voltage Supply Circuit for Magnetron	36
Figure 3.29	Equivalent Circuit of HV Power Supply for Microwaves Generator	36
Figure 3.30	B-H curve for SF19	36
Figure 3.31	Block Diagram of Non- Linear Inductance	37
Figure 4.1(a)	Power Meter	38
Figure 4.1(b)	Thermocouple	38
Figure 4.1(c)	Ambient and Cavity Temperature Reading on Testing PC	38
Figure 4.2	Cylindrical Container	39
Figure 4.3	Experimental Arrangement for the Testing of Microwave Oven	40
Figure 5.1	Mechanism for Resonant Drifting Electrons Interaction with a Traveling Wave	41
Figure 5.2	Magnetron Anode Vane	42
Figure 5.3	Simulink Model for High Voltage Supply for Magnetron	43
Figure 5.4	Simulation Circuit of Voltage Doubler Circuit	43
Figure 5.5	Simulation Circuit of Nonlinear Inductance	44
Figure 5.6	Flux Vs Current Curve of Primary and Secondary Side	44
Figure 5.7	Flux Vs Current Curve of Shunt in HVT	45
Figure 6.1	Electron Distribution at 14.37 ns	47
Figure 6.2	Spokes in Magnetron at 90.42 ns	47
Figure 6.3	Particle Distribution in Old Magnetron	48
Figure 6.4	Particle Distribution in Proposed Magnetron	48
Figure 6.5	Evolution of Output Voltage with Time	48
Figure 6.6	Anode Voltage for Case 1 (a) Experimental; (b) Simulated	49
Figure 6.7	Anode Voltage for Case 2 (a) Experimental; (b) Simulated	49
Figure 6.8	Anode Voltage for Case 3 (a) Experimental; (b) Simulated	49
Figure 6.9	Anode Voltage for Case 4 (a) Experimental; (b) Simulated	50
Figure 6.10	Anode Voltage for Case 5 (a) Experimental; (b) Simulated	50
Figure 6.11	Anode Voltage for Case 6 (a) Experimental; (b) Simulated	50

# LIST OF SYMBOLS

$\vec{F}$	Lorentz force governs the motion of an electron
$\vec{v}$	velocity of electron
$\vec{E}$	radial Electric field
$\vec{B}$	Axial Magnetic Field
$q$	Charge of electron
$\vec{v}_d$	Drift velocity of electron
$r_c$	Cathode Radius in Magnetron
$r_a$	Anode Radius in Magnetron
$V_h$	cut-off cathode-anode voltage in Magnetron
$B$	cut-off static magnetic field
$\omega_e$	angular frequency of electron
$\omega$	Angular frequency of the RF Field.
$\omega_g$	resonator oscillation frequency
$C$	Capacitor of the resonant cavity
$L$	Inductance of the resonant cavity
$V_m$	RF Voltage Amplitude
$N$	Number of Resonant Cavity
$c$	Speed of light
$r_v$	Vane Radius
$f_n^o$	frequency when there is no axial mode effect
$h$	cavities axial length
$g$	axial mode number
$U_1$	Primary winding voltage in HVT
$U_1'$	Primary winding voltage referred to secondary in HVT
$i_1'$	Primary current referred to secondary
$i_2$	Secondary current
$r_1'$	Primary winding resistance referred to secondary
$r_2$	Secondary winding resistance
$n_1$	Number of primary coil turns
$n_2$	Number of secondary coil turns

$U_2$	Secondary winding voltage
$L_p'$	Primary inductance referred to secondary
$L_s$	Secondary inductance
$L_p$	Primary inductance
$i_p'$	Circulating current in inductance $L_p'$
$i_s$	Circulating current in inductance $L_s$
$i_{sh}'$	Circulating current in shunts referred to secondary
$(L_{Sh}')^e$	Air-gaps shunt inductance referred to secondary
$(L_{Sh}')^f$	Iron shunt inductance referred to secondary
$(L_{Sh}')$	Shunt equivalent inductance referred to secondary
$P$	Microwave output power (W)
$\eta$	Efficiency of microwave oven
$T_0$	Initial temperature of water ( $^{\circ}\text{C}$ )
$T_A$	Ambient Temperature ( $^{\circ}\text{C}$ )
$T_1$	Final Temperature of water ( $^{\circ}\text{C}$ )
$m_c$	mass of the container (g)
$m_w$	mass of the water (g)
$T$	heating time (s), excluding the heating up time required by magnetron filament
$W_{in}$	input Energy including the heating of magnetron filament
$\phi$	flux by turn
$S$	Section of the unbound core in HVT
$L$	average portion's length in HVT

# LIST OF ABBREVIATIONS

<b>MWO</b>	Microwave Oven
<b>HVT</b>	High Voltage Transformer
<b>BEE</b>	Bureau of Energy Efficiency
<b>MGT</b>	Magnetron
<b>VDC</b>	Voltage Doubler Circuit
<b>CW</b>	Continuous Wave
<b>GHz</b>	Gega Hertz
<b>PM</b>	Permanent Magnets
<b>EMF</b>	Electromagnetic Field
<b>DC</b>	Direct Current
<b>RF</b>	Radio Frequency
<b>ATC</b>	Air Traffic Control
<b>LINAC</b>	Linear Accelerator
<b>VMAT</b>	Volumetric Modulated Arc Therapy
<b>IMRT</b>	Intensity-Modulated Radiation Therapy
<b>IGRT</b>	Image Guided Radiation Therapy
<b>SBRT</b>	Stereotactic Body Radio Therapy
<b>DWR</b>	Doppler Weather Radar
<b>WSR</b>	Weather Surveillance Radar
<b>ATCRBS</b>	Air Traffic Control Radar Beacon System
<b>PIC</b>	Particle in Cell
<b>HV</b>	High Voltage
<b>LUT</b>	Lookup Table
<b>IEC</b>	International Electrotechnical Commission
<b>MW</b>	Mega Watt

# ABSTRACT

Nowadays, due to the concern regarding the environment, energy-efficiency enhancement in microwave ovens are required. This dissertation works presents the efficiency enhancement of a domestic microwave oven. The performance of the oven is calculated by using the test procedure discussed in IEC 60705. According to this standard, Efficiency of oven mainly depends upon the power output and output power depends upon the rise of water temperature. The temperature rise can be achieved by more microwave absorption by the load which intern can be achieved by increasing the number of waves generated by magnetron. As per the literature, 3-D particle in cell modelling in CST studio suite software is used for the modelling of the magnetron to examine the performance of the magnetron. The geometrical parameters of the magnetron are changes to achieve the desired efficiency for the oven. Further, modelling of the  $\pi$  quadruple model of a non-linear transformer with doubler circuit has been done in MATLAB Simulink environment. The simulated and experimental data has been collected and compared. It is found that there is less than 5% variation in the simulated and the experimental results. Also, the performance of the oven has been enhanced by approximately 4.5%.

**Keywords:** Microwave oven, Magnetron, High voltage circuit, Doubler Circuit,  $\pi$  Quadruple Model.

### 1.1 Introduction

Due to increasing real-estate prices, smaller kitchens are preferred by many consumers in their houses. For efficient use of space, the modular kitchen is opted by consumers, which enhance the demand for cooking appliances. Due to the development of the country, small kitchen appliances such as stove, cooker, etc., is expected to grow at a critical speed. With the improvement in lifestyle, high incomes, busy schedules, egress of double income families and rising in the women’s working culture have generated the market for the microwave oven (MWO). From the last century, the radio and microwaves are generally used for broadcasting and communication applications but after the invention of the microwave oven, it is used for the heating purposes. Electromagnetic waves having a frequency range between 300 MHz and 300 GHz and corresponding wavelength from 1m to 1mm are known as Microwaves as shown in Figure 1.1 [1]. There are many applications where microwave energy is used such as rubber vulcanization, communication, food processing, chemical reactions, drying and medical related fields [2].

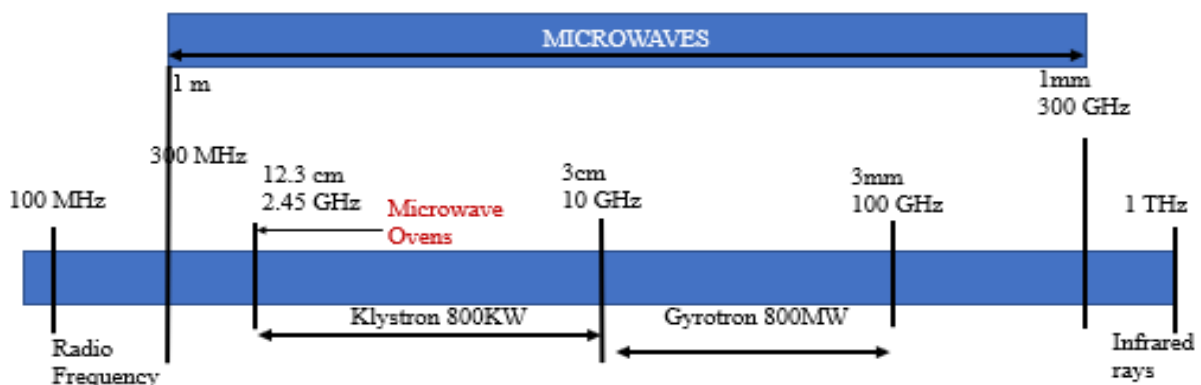

Figure 1.1: Range of Microwaves

In Microwave ovens, heating is taking place using microwaves. The conversion of electromagnetic energy into thermal energy is known as Microwaves heating. Microwaves heating have many applications such as cooking, tempering, sterilization, blanching baking and drying [3].

The principle of microwave heating is based on the dielectric heating. In dielectric heating, water molecules act as a dipole magnet due to the partial positive and negative charge. The microwaves i.e. fast-changing field present in the MWO cavity is faced by the water molecules. This produces friction between the water molecules and hence generated the heat.

The energy present in microwaves is directly transferred to the material through the interaction of molecules with the electromagnetic field.

Microwave oven is made up of the following mechanical and electrical components such as a high voltage transformer (HVT), magnetron (MGT), voltage doubler circuit, cooling fan motor, cooling fan, turntable motor, turntable plate, high voltage fuse, waveguide cover, plug, power cord, bulb, thermostats, micro switches, cooking chamber, upper and lower case. HVT with voltage doubler circuit is known as high voltage circuit in the microwave oven. Doubler circuit helps to increase the magnitude of the incoming voltage. This voltage act as input to the magnetron. The microwaves are generated with the help of magnetron and move to the cavity of the oven through a waveguide. MGT is also known as a microwave generator. Food which is acting as load present in the cavity. Microwaves penetrate inside the food and produce vibration in the water molecules hence heats the food.

## **1.2 Need Analysis**

In today's era, a different organization including government and private are much focusing on the generation of the most efficient product. This is because of the direct linking of energy generation with the environment and the global warming issues. Global warming and policies for environmental protection have to turn out an important issue that remains in international discussions. In this situation, Energy efficient products play a major role in reducing the energy losses. Government of India has been taking steps for the efficiency enhancement of the appliances that are used in day to day life. Bureau of energy efficiency (BEE) come with an important step i.e. a labelling program for the high energy consumption products [4]. The Objectives of the labelling program is to give choice and knowledge about the energy saving product to the consumer and thereby enhance the cost-saving capacity of the market and other equipment [5]. It is expected that by launching the star rating program, approximately 3 Billion units of electricity could be saved by 2030 [6]. Till now, most of the appliance are labelled as per the energy star rating such as refrigerator, Air conditioner, etc., but microwave ovens are not. Therefore, it is required to provide an energy star rating for the ovens so that more energy efficient product will be purchased by the consumer and devote their contribution for the saving of energy and helps for the environment protection.

### **1.3 Aim and Objectives of Thesis**

The ambition of this dissertation is in the direction of efficiency enhancement of microwave oven with the help of more efficient type continuous wave magnetron and the high voltage circuit.

Objectives of the thesis includes,

1. The more efficient microwave oven.
2. To improve the magnetic field uniformity in between the interaction space of magnetron.
3. To improve the particle interaction with the electromagnetic wave inside the cathode-anode cavity.
4. The optimized design of microwave generator i.e. vanes type continuous wave magnetron.
5. Simulation of the magnetron in CST particle in cell simulator.
6. To reduce the operating time for the stabilization of voltage in the magnetron.
7. Impedance matching in between High voltage circuit and Microwave generator.

### **1.4 Organisation of Thesis**

This thesis is divided into 7 chapters:

**Chapter 1** contains the introduction, need analysis, and objectives of the thesis.

**Chapter 2** presents the overview of earlier work on the microwave oven and its components. This chapter also includes the gap in the study with the formulation of objective and the novelty in the work that has been done in this thesis.

**Chapter 3** includes the detail description of each component in the microwave oven. It also includes a brief description of the design and modelling of the magnetron and high voltage circuit.

**Chapter 4** presents the efficiency and power output testing method on the oven as per IEC standard.

**Chapter 5** presents the design methodology, constraint and assumption of the proposed system.

**Chapter 6** contains the result and discussion on the proposed system.

**Chapter 7** contains the conclusion of the thesis work along with scopes for the future research work.

### LITERATURE SURVEY AND PROBLEM FORMULATION

---

#### 2.1 Earlier Works – An Overview

From last century, radio and microwaves are used for communication and broadcasting applications. During World War II, Dr. Percy LeBaron Spencer accidentally found the effect of heating by microwaves. Hence microwaves are used for heating purposes such as in microwave oven & industrial heating. The first microwave oven was produced by Raytheon Corporation in 1946. Further the advancement in technology and earlier work on microwave oven has been discussed below:

C. J. Budd *et al.* [7] discussed the heating problem in the microwave oven to the foodstuff, allowing for drying and phase change. The approximation has been derived for the field that contains both an oscillatory component and exponential decay term using the Lambert law. Using these approximations, it is found that the foodstuff temperature is in good relation as in previous cases. The drying effect has been studied and it is found that the dielectric properties of the material changes by using this process. An accurate and fast numerical method for smoothing the phase transition is also derived.

M. E. C. Oliveira *et al.* [8] presented the microwave power absorption in a model by determination of Maxwell's equation and then use these terms as a source in the transient heat equations. Heating of foodstuff using microwaves is simulated by the proposed methodology. Governing equations were discretized using the finite element method. After the simulation, it is found that the heating through microwaves mainly depends upon the shape and size of the sample. The penetration of radiation and absorption of power is significant at lower frequencies. The power distribution using Lambert's and Maxwell's equation has been calculated and compared. It is found that the limit in the Lambert is higher for the cylinder with respect to the slab. Different materials are simulated which result in different power distribution are represented.

J. M. Osepchuk [9] presented the detailed history, future, and current trends during the evolution of the microwave oven. It also discussed the allegations regarding neglecting the contribution for magnetron and radar in Japan and Europe. Different conclusions have been derived using the history of the microwave oven. It is concluded that for accurate history, continuous inputs from the knowledgeable persons is required.

J. M. Osepchuk [10] reviewed the development in the heating application of microwaves.

The residential and commercial use of microwave oven starts after world war II. It was seen that in early sixties microwave power owns a new market and as a result, there were a creation of International Microwave Power Institute. The rise in the business of oven has been discussed and the limitation for the future development of the microwave oven due to the environmental regulation related to the compatibility of electromagnetic waves has been incorporated in this paper.

D. Calmettes *et al.* [11] discussed the invention of the high voltage transformer that is used for the supply of a magnetron. It describes the different parts, material used for the designing of the transformer and offered the drawings of each part with its explanation.

P. Redhead [12] discussed the development in the magnetron at the time of second world war. It also discussed the fetching of magnetron from the UK to North America. Different type of cavity magnetron and their impacts has been incorporated in this paper. Different application for magnetron such as for the kitchen, radar system, air system, etc. has been discussed.

G. Churyumov *et al.* [13] presents the theoretical and experimental investigation of Ku and X range magnetron with cold secondary emission cathode and two RF energy output. It is found that the tuning frequency range for the magnetron lies above the 200 MHz. Microswitch with p-i-n diodes are used for the controlling of the tuning frequency. It also represents the droop and front anode voltage pulses. The possibility for the expansion of such magnetron has been discussed.

I. Araz *et al.* [14] presented the simulation of vane type magnetron that has been done on CST- PIC solver with its electromagnetic effect. The RF frequency of the 18 anode vanes without straps have been chosen in X band and simulated the results. It is concluded that by adjusting the magnetic field and applied voltage values along with the cavity dimensional values would improve the magnetron simulation.

A. W. Hull [15] deduced the equations for the electron motion between anode and cathode in the cylindrical magnetron. The magnetic field is considered as constant in nature. Current with constant magnitude curves as a function of a magnetic field has been demonstrated for different filament temperature, voltages, and anode diameters. These curves are in error limits with respect to the theoretical analysis.

H. Boot *et al.* [16] presented the importance of the magnetron invention. Early research and the developments in the magnetron have been elaborated. Different types of magnetrons, strapping effects and magnetron operation has been discussed.

D. Andrey *et al.* [17] simulated and built a prototype of slot and hole type magnetron with

four cavity that had already been created during 1936-37 using modern computer codes. First magnetron with 4 cavity generated 300 W of power generated with 20% efficiency and operates at 9 cm. SUPERFISH code is used to analyse the "cold" resonance frequencies. Cold resonance frequencies are used to calculate the Hull and Hartree thresholds voltages that are showing in the operational domain of the magnetron. MAGIC code is used for the PIC simulations by creating a virtual prototype of the magnetron. The simulation result shows the designed magnetron in centimetre band produces high power microwaves.

E. C. Megaw *et al.* [18] describes the events and amount of work has been done after the war that results in the development of first high-power pulsed magnetron having 10 cm wavelength. Gutton developed the large oxide cathode whereas Boot and Randall developed the multi-resonator type magnetron. A new magnetron is designed using the above properties with a permanent magnet that fulfil the airborne service requirement. The life and pulse power enhanced by a factor of 10 with a reduction in the weight of the magnet. At the early period of expansion in the magnetron, there were fundamental difficulties in the design of multi-segment magnetron and, the experimental study and ideas of that time were very incomplete.

M. Leconte [19] discussed the technical development of magnetron with respect to the war within the organization named as young radio. Patents registered by companies; inventors have been presented with their classification. The strategical study by the companies helps the technical enhancement of magnetron. Additionally, a method is proposed for the patent classification can be considered as a heuristic for such queries.

R. Chandra *et al.* [20] simulated and designed a relativistic magnetron with axial power extraction. Further relativistic magnetron design features are presented. Constitute a Linear Induction Accelerator that uses magnetic switches for high repletion rate. 100 MW power output is expected when magnetron operates at full rating. It is found that the output power mainly depends upon the applied current and voltage.

C. Ernest *et al.* [21] discussed the different type of magnetron. The invention is related to the microwave generator and other devices that have the microwave range frequency or ultra-high frequency or the devices that have 1 - 100 centimetres wavelength.

A. Andreev *et al.* [22] presents the simulation of ultra-high frequency non-relativistic strap magnetron in particle in cell simulator. The functional and dimensional parameter's value of this magnetron is near to the industrialized heating high powered magnetron that generates CW- Microwave power of approximately 75-100 kilowatt. PIC simulation has an important feature that includes the progression, the development and the beginning of the MW

oscillations without the use of priming by artificial Resonant Frequency. Electromagnetic — noise because of the electron interaction in the electron cloud inside magnetron has been simulated. The result shows that there are maximum and minimum input voltages above and below which the microwave generator fails to oscillate under  $\pi$ -mode even if there is no mode competition i.e. no other operating mode is excited.

K. W. Dudley *et al.* [23] disclosed the traveling wave crossed field device. This device has a dual set of cathode electrode which is conductive in nature. Dual sets include the emitter and the control element. The requirement of low voltage control makes the high-speed shutoff and high-micro switching characteristics.

T. P. Fleming *et al.* [24] presented the conventional magnetron prototype and its simulation. This magnetron has an efficiency of greater than 87% and RF power output exceeding 1.3 MW for a 40kV low diode voltage. Designing of magnetron has been done in 3-D electromagnetic particle-in-cell code. Voltage and a magnetic field is varied from 37–56 kV and  $B = 0.18$  T to  $B = 0.275$  T. The simulated result demonstrated that the efficiency is greater than 85% and power output range lie from 400 kW–1.5 MW. It is also found that the oscillations are robust and stable under  $\pi$  mode with very less competition in modes at 912 MHz over voltage and magnetic field range. Losses in magnetron occur because of the collisions and back bombardment of the electron with the slow wave structure and cathode of the magnetron.

H. S. Uhm *et al.* [25] presented that the injected helix inside the cylindrical type electrode in magnetron achieved a dispersion relation in between EM- waves propagated over a helix. During this case, model of magnetron vane disappears and standard dispersion relation of helix were improved. In spite of this, if the angle of helix pitch approaches to  $\pi/2$  then the come-out dispersion relations also improves the TE- mode of a magnetron.

E. Melgoza *et al.* [26] introduces a method for the finite element field solvers and electromagnetic coupling transient program. Magnetic device detailed structure with saturation effect is considered and a matrix is defined by considering the set of inductances parametric values. Further transient program is communicated by these values and for the device true operating point, these parameters are updated at each time step. Also, the use of delay time in a transient program with its effect on parameter computation has been investigated.

M. O. Ahmedou *et al.* [27] proposed a new power supply to the magnetron using single phase HV leakage flux transformer. Two cells are supplied by this transformer which is composed of a diode and capacitor that stabilizes the current and increase the voltages. Each

magnetron is supplied by a single cell. The new model has been proposed for this transformer with shunts. Two magnetrons have been used in this system. The proposed model is made by using B-H magnetization curve and determine the nonlinear storable inductances expression. Further model has been implemented on MATLAB-SIMULINK® tool and result were compared with old model made by using EMTP. Also, optimization strategy has been discussed to visualize the possibility of reducing the weight, section, space and the cost of the transformer.

M. Bassoui *et al.* [28] proposed the modelling of high voltage three-phase power supply for the one microwave generator under MATLAB SIMULINK environment. The design includes the cell doublers, composed of a diode and a capacitor that supply the new three-phase transformer. Anode current stabilization in magnetron has been achieved by de dimensioning of a three-phase transformer with a magnetic shunt. Also, each magnetron is supplied by a single cell. The model has been tested and various curves of current and voltage are traced. It is found that the simulated and experimental result is approximately the same for the conventional power supply for single magnetron using a single-phase transformer.

M. O. Ahmedou *et al.* [29] developed an improved  $\pi$  quadruple transformer model. This model has been designed by considering the saturation phenomenon. Designed model is made by using B-H magnetization curve fitting and determine the nonlinear storable inductances expression. Further for the analysis curve breaks into two parts: one is the saturation region represented by the polynomial expression and other is the linear one which has been achieved by non-integer power series fitting. The model has been validated by using the MATLAB- SIMULINK® code and the result for simulated and experimental voltage and current has been compared. These results also compared with the Electromagnetic Transient Program code (EMTP). It is found that the result from the simulation is matched with the experimental measurement.

G. Liu *et al.* [30] presented the improved modelling of a ferromagnetic material curve which is nonlinear in nature. Data sets were measured and been used to represent the B-H curve with the help of Fourier series. Magnetic energy density is calculated using Fourier series expression and further Ferromagnetic material permeability has been determined using the iterative procedure. finite-element method is employed to enhance the model's accuracy. Also, magnetic field and zero-sequence impedance have been investigated for underground pipe-type cable. Computational result and measured data are compared and it is found that they are in good agreement.

M. O. Ahmedou *et al.* [31] presented the elevated procedure for the modelling of a special

transformer made up of SF19 ferromagnetic material with shunts. Non-linear characteristics of the transformer B-H curve has been presented. Two analytical expressions have been made, first is for linear part which includes non-integer power series and other is for saturation region that contains the polynomial expression. Nonlinear inductances have been calculated with the help of Lookup Table block introducing point by the point value of B and H and deduce the value of  $\Phi$  & I in MATLAB-SIMULINK. Simulation of high voltage circuit has been done in MATLAB environment that provides power to the magnetron. The simulated and experiment results of current and voltage curves are compared and it is found that there is approximately error of 1% in the curves.

M. Bassoui *et al.* [32] developed a procedure to optimize the three-phase transformer geometry by considering the supply condition given by the manufacturer using MATLAB SIMULINK environment. The proposed design contains a voltage doubler circuit made up of a diode and a capacitor. Doubler circuit supplies the voltage to the magnetron. As per the optimized designed model, there is a net reduction in the volume of the transformer and also reduces the cost of the system.

A. Belhaiba *et al.* [33] presented the approach of electrical functioning of microwave generators used for the powering the magnetron. Experimental and simulated signals are obtained and compared to accredit the power supply functioning of one magnetron. MATLAB-SIMULINK environment has been used to simulate the  $\pi$  quadruple model of the transformer. Energy balance for one magnetron is established and compared experimentally. Conservation of fluxes has been checked as per the simulated flux values and it is found that they were in good agreement.

Y. Zhang *et al.* [34] simulated the Magnetic flux leakage transformer (MLFT) using load magnetron with the help of field-circuit coupled model. Load characteristics, magnetic field and power supply circuit of the MFLT's is considered and the dynamic and static performance was obtained. Computer simulation has been studied for the control scheme behaviour, characteristics of the load and values of L and C. The proposed simulation model correctness is achieved by comparing the experimental and simulation results. The results are consistent with the experimental results.

J. H. Chan *et al.* [35] described the multiple windings and non-linear core transformer model and implemented in DSPICE. Formulation of minor and major loops and the transition algorithm between hysteresis loops is described. The temperature, modelling of losses and frequency dependence are also presented.

B. Bahani *et al.* [36] proposed the modelling of high voltage power supply consisted of

transformer and doubler circuit composed of a diode and a capacitor for the three magnetrons.  $\pi$  model of the transformer is simulated considered the saturation phenomenon in MATLAB Simulink environment. This system is capable of supplying 2400 Watt. Non-linear inductances expressions have been determined using B (H) magnetization curve for the used material. The experimental and simulated result is compared and these results are in good agreements. The recommended condition by the constructor is also full fill successfully.

A. Belhaiba *et al.* [37] proposed the modelling of high voltage power supply consisted of transformer and doubler circuit composed of a diode and a capacitor for the two magnetrons.  $\pi$  model of the transformer is simulated in consideration with the saturation phenomenon in MATLAB Simulink environment. MATLAB Simulink tools help us to view the optimization possibility as a result of which there would be a reduction in the volume of the transformer and the implementation cost of the system. Further simulated and the experimental results are compared and it is found that they are in good agreements.

International standard IEC60705 [38] has been used for household used the microwave oven. The standard is also applicable to combination microwave ovens. This standard is used to determine the performance characteristic of a household microwave oven along with this it represents the measuring characteristic methods. Different tests are defined along with their general conditions and assumptions.

A. Bouzit *et al.* [39] simulated the high voltage power supply for the transformer with shunt having multiple magnetrons under EMTP code. Control of current through magnetron and transformer geometrical parameters have been determined using EMTP code. Also, Possible states that would happen during operation has been considered such as failure of both magnetrons, failure of one other working and both magnetrons are in service.

M. Vakilian *et al.* [40] proposed a nonlinear transformer model and a method to predict the magnetic core nonlinear characteristics during the transient condition. Under solution interval time, saturable core's characteristic has been linearized. The verification of the single phase, the non-linear transformer model has been done with respect to measured data.

## 2.2 Gap of Study

1. Low availability of a uniform magnetic field in between the interaction space of magnetron.
2. Less interaction of particles with the electromagnetic wave inside the cathode-anode cavity.
3. Improper matching of high voltage circuit with the microwave generator.

4. Lack of analytical theory for the design and simulation of magnetron because of its nonlinear nature.
5. A requirement of more time for the stabilization of voltage in the magnetron.

### 2.3 Formulation of Objectives

To design a microwave oven which is more efficient and have high efficiency.

The Power and efficiency of the microwave oven is calculated by

$$P = \frac{4.187 \times m_w(T_1 - T_0) + 0.55 \times m_c(T_1 - T_A)}{t} \quad 2.1$$

$$\eta = 100 \frac{P \times t}{W_{in}} \quad 2.2$$

So, efficiency can be increased by increasing the power output of the oven. Power output depends on the temperature rise of the water. Higher the temperature rise, higher power output and efficiency.

High voltage circuit and Magnetron design such that,

1. Input voltage to the MGT should be in permissible limit through high voltage circuit.
2. More number of microwaves should be generated by the magnetron and consumed by the load.

### 2.4 Expected Deliverables

1. More efficient microwave oven (Efficiency enhancement by approx. 4 ~ 5%).
2. To be able to get a uniform magnetic field by permanent magnets.
3. There will be maximum interaction of particles with the electromagnetic wave in the magnetron by reducing the anode-cathode gap.
4. There will be an increase in the number of favourable electrons by uniform magnetic field and reduced interaction space in the magnetron.
5. The input supply to the magnetron is in the limit by the high voltage circuit.

### 2.5 Novelty of Work

1. Permanent magnet with increased in size is successfully able to provide improved magnetic field in between the cathode-anode space.
2. Reduction in the Anode and cathode gap with improved magnetic field helps the particle to transfer their potential energy to the electromagnetic wave and improves the interaction in between them.

3. Increase in the anode vane radius towards the cylindrical cathode side with uniform magnetic field provided by the permanent magnet helps to achieve the optimise design of the magnetron. The optimised design reduces the voltage stabilization time in the microwave generator.
4. High voltage transformer with optimised number of turns and voltage doubler circuit make the balancing in between high voltage circuit and magnetron.

### 3.1 Microwave Oven

An electric oven is known as a microwave oven that cooks and heats food using electromagnetic radiation in the microwave frequency range. Microwave frequency are used for the generation of heating effect in the microwave oven. Wave contain both magnetic and electric field properties known as electromagnetic waves. Microwave reacts with the positive and negative charge present in the polar molecule. Heating will take place because of the interaction of electric field component with the sugar, fat, and water which contain polar molecules. The food molecular structure contains dipoles due to this microwave frequency creates vibration in them and align themselves in the direction of the electromagnetic field which is varying rapidly. This vibration creates friction in the molecules hence generates heat in the food [7]. The major advantage of microwave heating as compared to conventional heating are shorter processing time, size, energy efficiency and faster heating rate of the ovens [8]. Figure 3.1 represent the block diagram of the microwave oven.

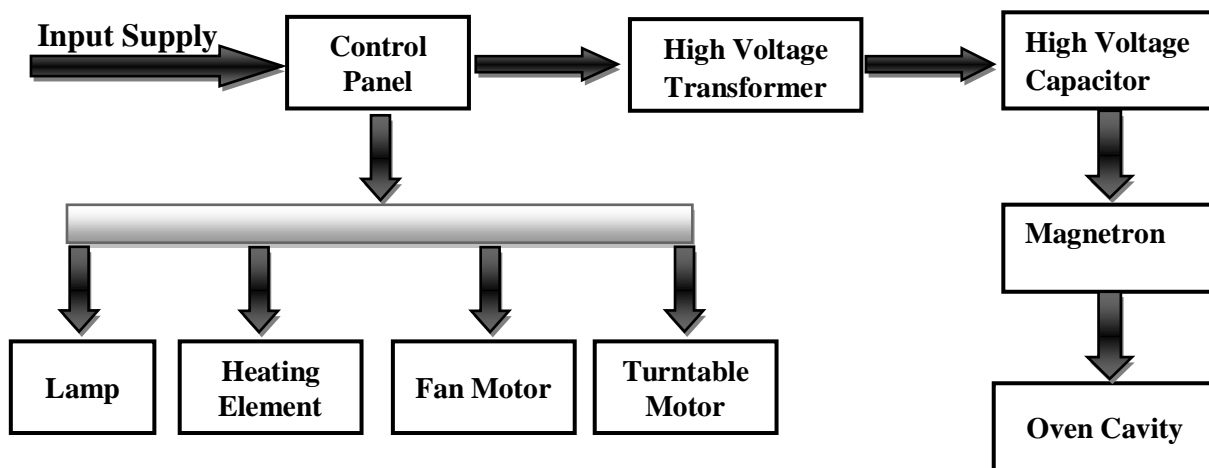

Figure 3.1: Block Diagram of Microwave Oven

### 3.2 Brief History of Microwave Oven

Raytheon Corporation patented and produce first microwave oven in 1946. Initially, microwave ovens were large in size and less economical as shown in Figure 3.2. After the advancement in technology, ovens become cheaper and smaller in size. Hence there was an increase in the sale of the oven for the household applications [41], [9].

The first household microwave oven was called Amana Radarange, built in 1967. This oven worked at 115-volt supply. It has two knobs for cooking, one for long time i.e. up to 25

minutes and another for small-time i.e. 5 minutes. Along with this it also had “*start*” and “*light*” buttons [9], [10].

Nowadays, the weight and size of the oven have been reduced due to the advancement in the technology. The weight of the typical microwave oven will lie in between 10kg to 25kg and the cost for the same in between £40 to £200. The cost and the weight vary according to the model to model.



Figure 3.2: Radarange Developed Microwave Oven [41]

Today it can be seen that there are varieties of ovens available in the market with digital or manual control.

### **3.3 Components of Microwave Oven**

A Microwave oven consists of electrical and mechanical components. The main components of the oven are discussed below.

#### **3.3.1 High Voltage Transformer**

The Transformer is used to transfer the voltage from one level to another level at a constant frequency. In MWO, it is used to give power to the magnetron that generates the waves and enable the MWO to operate as shown in Figure 3.3. It includes two cores made up of steel with E shaped and two insulated windings known as coils made of copper. The low input voltage connected to the primary coil, whereas the secondary coil produces a high-voltage output. Further, the doubler circuit connected to the high voltage transformer (HVT) secondary that generates DC power to the magnetron. The gap between primary and secondary winding are filled with insulation materials [11]. Generally, the primary and secondary voltage of HVT is 230V-240V AC and 2000V to 2300V in AC at 50 Hz respectively. The range will depend upon the type of the oven.

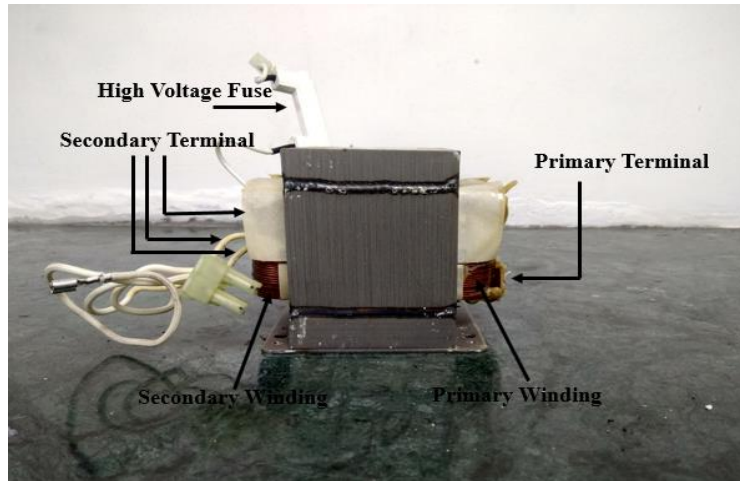

Figure 3.3: High Voltage Transformer and High Voltage Fuse

### 3.3.2 Voltage-Doubler Circuit

Doubler circuit includes diode and capacitor assembly. This assembly is used to twice incoming high voltage in the circuit that is 2000V AC in transformer secondary to 4000V DC. This high DC is used to supply magnetron tubes. Due to the fact that voltage is raised to twice its level the circuit is called as voltage doubler circuit (VDC). Figure 3.4 shows schematic diagram of VDC. Further the output of the combined circuit is in connection with magnetron. The assembly of diode and high voltage capacitor applied in oven is shown in Figure 3.5.

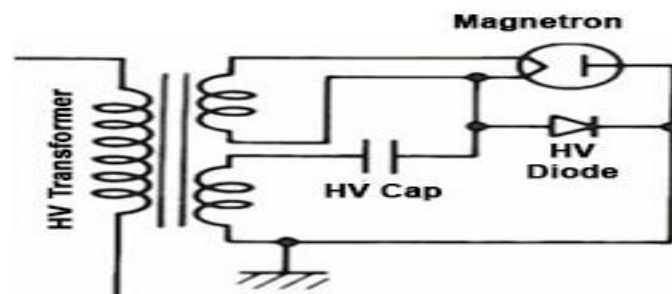

Figure 3.4: Schematic Diagram of a Voltage-Doubler Circuit

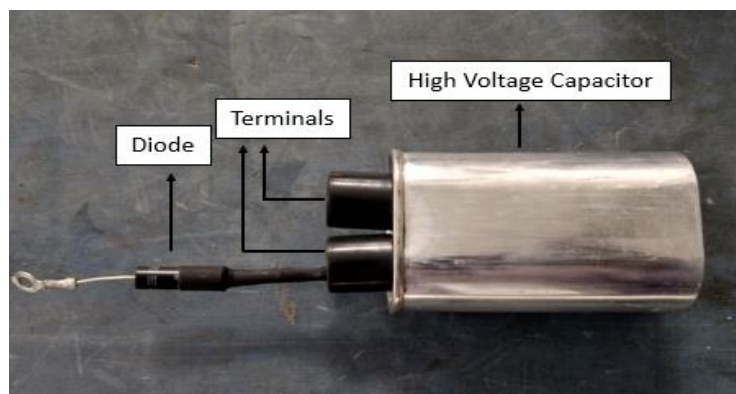

Figure 3.5: High Voltage Capacitor and a Diode Used in a Microwave Oven Assembly

### 3.3.3 Magnetron

It is a source for the generation of microwaves. In February 1940, Randall and Boot built the multi-cavity magnetron. It has a wavelength of 9.8 cm and produced a continuous power of 400 W [12]. As per the requirement of the lightweight and compact ovens, design of magnetron changes and it became lighter and thinner as compared to the previous version of the magnetrons.

Continuous wave (CW) magnetron is used in a domestic microwave oven as these have continuous power from few watts to 10kW. The operating frequency of magnetron is 2.45 GHz and the efficiency is around 40- 70%. Magnetron converts the potential energy of electron with the help of a magnetic field into the microwave energy therefore, it has high variable efficiency. These are air cooled with the help of a cooling fan installed in the oven.

Highly conductive copper is used for the resonant cavity of a magnetron. Metal strap is used for the magnetron assemblies as shown in Figure 3.6. Two permanent magnets (PM) are used for the generation of a magnetic field in the magnetic circuit. Anode and cathode (filament) are connected to the +VE and -VE side of the power supply respectively. The cathode (filament) and cylindrical anode are there for the emission of electrons and they are placed in between the cylinder. The loss in microwaves is reduced by anode which is made up of copper and act as a resonant cavity for the filament (cathode). Yoke and Pole piece made up of iron is used for the magnetic circuit of the magnetron. Microwaves energy are transmitted to the cavity through a waveguide with the help of antenna which is connected to the magnetron. The filter circuit is added in the magnetron to limit the leakage of unwanted radiation in the magnetic circuit [13].

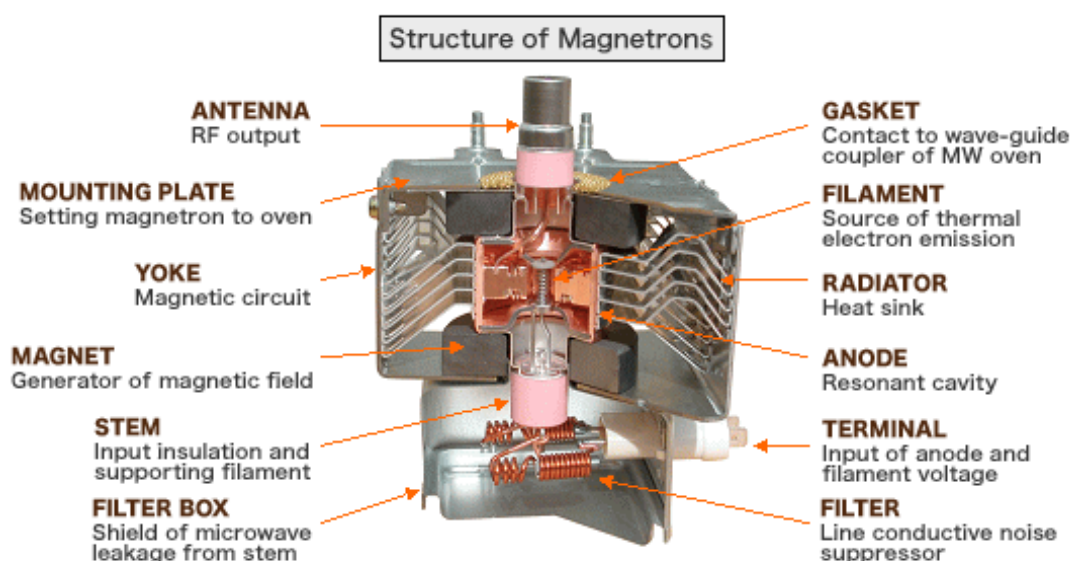

Figure 3.6: Structure of a magnetron and its sub-assemblies [42]

### 3.3.4 Waveguide

It is a metallic tube which is used to transfer of microwaves energy generated by magnetron to the oven cavity. Waveguide cover generally made up of plastic or mica sheet is used to prevent the spillage of food into the waveguide. Magnetron antenna is placed into the inlet of the waveguide. Figure 3.7 shows the waveguide and its cover position in the microwave oven.



Figure 3.7: Waveguide in The Microwave Oven

### 3.3.5 High Voltage Fuse

Capacitor and HVT secondary are connected with high voltage fuse as shown in Figure 3.2. This fuse provides protection to the user and microwave oven in case of short circuit. If the fuse is blown, oven may operate without magnetron heating in the cavity.

### 3.3.6 Cooling Fan

MWO assembly includes motor and cooling fan. Motor and cooling fan provides cooling when the magnetron is in operation. In Figure 3.8 MWO chassis have been mounted with cooling motor and fan.

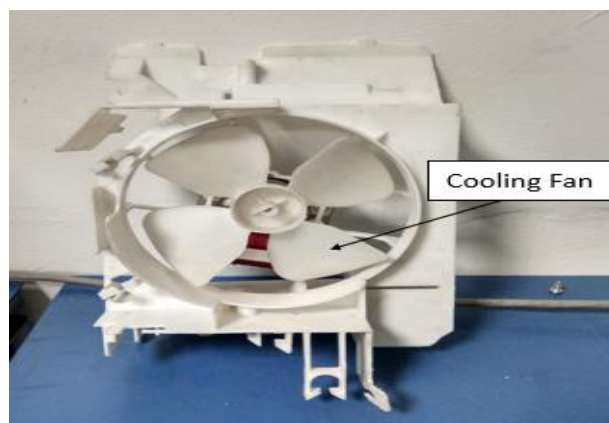

Figure 3.8: Cooling Fan Mounted to a Microwave Chassis

### 3.3.7 Plug and Power Cord

MWO gets supply via electrical plug and power cord as shown in Figure 3.9. This assembly is connected to the 220V mains supply. PVC insulated fine gauge copper wire is used to make a power cord, which insulates phase, earth and neutral and PVC sheath further enclosed this assembly.

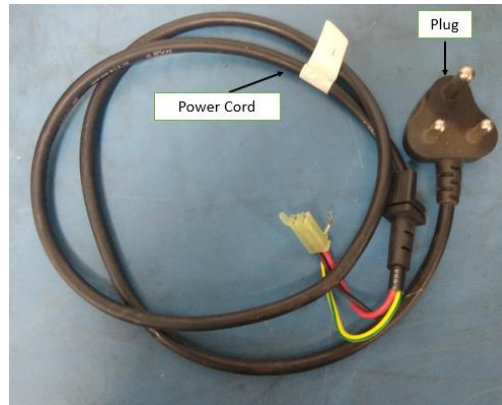

Figure 3.9: Electrical Plug and Power Cord

### 3.3.8 Thermostat

Thermostat primarily constitutes of plastic and aluminum and finds application in controlling temperature of the cavity along with magnetron as shown in Figure 3.10. The cavity temperature is controlled by the presence of secondary thermostat.



Figure 3.10: Thermostat in Microwave Oven

### 3.3.9 Bulb Holder and Bulb

Bulb holder and bulb finds a place inside MWO assembly. These are made from plastic, metal and glass. The bulb holder is pinned or screwed with chassis of the oven. Holder is connected with the control circuit through 2 wires and the supply to the holder is fed from circuit board present in the oven assembly. Figure 3.11 represent the bulb, bulb holder assembly.



Figure 3.11: Bulb and Bulb Holder Assembly

### 3.3.10 Turntable Plate and Turntable Motor

Turntable plate and motor are located under the cavity of the oven as shown in Figure 3.12. The constituent for the plate is glass whereas ferrous metal and plastic are used for motor. Turntable plate is used to provide unified heating with a flow of standing wave pattern through the food.

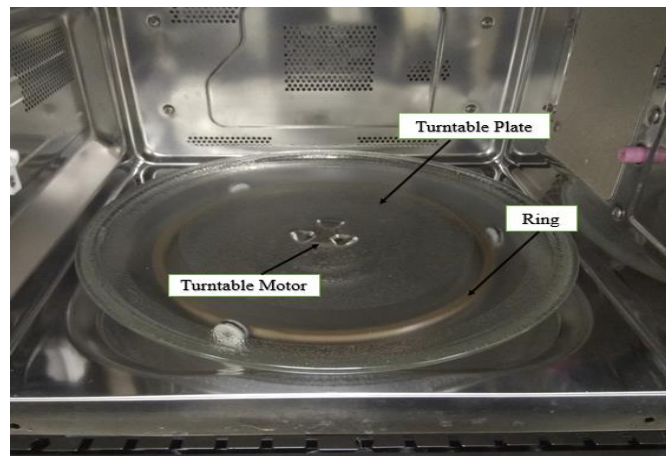

Figure 3.12: Turntable Motor and Plate in Microwave Oven

### 3.4 Magnetrons

Magnetron (MGT) is an oscillating device and it is a source for microwave energy. It has been popular among the researchers from the time it was invented. Being utilized in the radar system, magnetron has great influence in world history and changed the destiny of world war II. The higher power output of MGT with compact radar and small antenna helped its installation in ships, planes and land vehicle [43]. The systems that were used in war were dependent on the functioning of the magnetron. Hence major study over magnetron was done during the time of war. After war, the introduction of new technology led to new devices with higher microwave power output as compared to the magnetron. Hence the new technology took the application of microwaves in MWO.

The electrons in the magnetron are released by the vacuum tube system that produces the electromagnetic field (EMF). This field lies in the range of megawatt. Interior model of the magnetron is classified into two parts that are cathode and anode. The cathode is positioned at the centre of the MGT and is accompanied by resonators. The cathode is kept and stayed along with large filament leads that are sealed as per technical requirement in the form of tubes. Anode of MGT has a different type of structure namely: Vane-Type, Hole-Slot and Rising-Sun. DC source is used to energize the anode and cathode in the magnetron. The electrical and magnetic field are orthogonal to each other and place in the interaction space formed between the cathode and anode [14].

### 3.4.1 Magnetron History

The first magnetron was invented by H. Gerdien in 1910. Albert Hull discovered Split-Anode type of Magnetron in the year 1920 [15]. The earlier magnetron shown in Figure 3.13(a) has cylindrical shape anode. But their application was little because of insufficiency in high frequency.

Various researchers from the era of 1920 and 1930s experimented in the magnetron. In the beginning, the power level of the device was 100W [44]. Okabe developed split-anode magnetron in the year 1929. In this magnetron, the anode was dissected into 2 parts. The major disadvantage of this device was its efficiency and output power was significantly low [16]. Posthumous in the year 1935, discovered theoretically that larger magnetic field with multi-segment anode will lead to increase in the efficiency and RF power output of magnetron. As per his theory, the efficiency of magnetron as shown in Figure 3.13(b) that operates at 600MHz was approximately 50%.

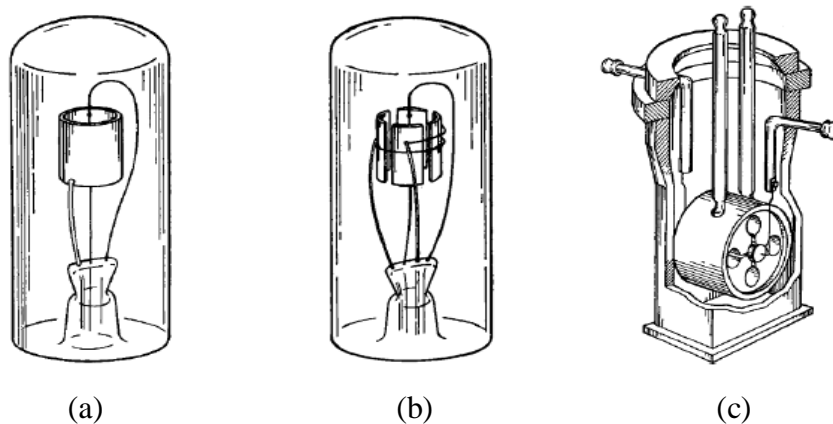

Figure 3.13: Types of Magnetrons (a) Cylindrical Diode; (b) Multi-Segment Anode Magnetron; (c) Hole-and-Slot Resonator Magnetron [45]

D.E. Malyarov and N.F. Alekseev developed multi-cavity magnetron with blocks of anode in 1936. The special feature of this magnetron was that it was encapsulated with cooling mechanism and cooling was done with the help of running water [17]. Malaroff and Alekseroff built magnetron with hole-slot resonators and copper anode in the year 1938. In this magnetron the cathode was made from tungsten helix and had a power output of 100W with wavelength of 10cm [18]. John Randall and Harry Boot enhanced the cavity-magnetron tube lateral in 1940 as shown in Figure 3.13(c) [19].

Initially the magnetron suffered poor stability that was resolved by invention of Rising –sun geometry and strapping method [44], [32]. The motion of an electron acts as a source of magnetron in combination with the magnetic and electric field. Hull developed a magnetron in 1921 that has co-axial cathode with cylindrical anode [14].

Due to the cylindrical design of anode, the output and efficiency of the Hull discovered magnetron were low. In 1935, anode design was updated by increasing the number of resonators and hence capability of the magnetron was enhanced. An advanced type of MGT with six cavity anode was developed by Boot and Randall in 1940. It includes new research that developed 2 types of resonator: without strap and with strap [20]. Further, a lot of devices based on microwave has been developed that had application in amplification and generation of microwaves. The application of magnetron has been extensive in radar electronic warfare, electron accelerator and microwave ovens.

### **3.4.2 Structure of Magnetron**

In magnetron, the magnetic and electrical field combine together to produce microwaves. A Magnetron is an oscillator. As compared with other microwave sources, magnetron is self-excited and does not require any external source for oscillations. Therefore, magnetron differs from other sources such as TWTs and klystrons. As per literature Collins described magnetron as a diode that produces an electromagnetic wave in the presence of a magnetic and electric field. The reason behind calling magnetron diode was its structure, which consists of cathode and anode pair through which electrons travel. The radio waves oscillations are stimulated by the electrons passing through the cavity opening.

In the cavity, resonant frequency founded and microwave frequency are generated. Because of increased DC power supplied to the magnetron it works as an oscillator and not as an amplifier. In case of magnetron, filament lead holds cathode which is located at the centre of the anode. The resonant cavity is a hole-slot type area in between anode and cathode. Under

this area, the radio frequency field is produced. The heating effect of a magnetron is reduced by cooling fins. A magnetron model is shown in Figure 3.14.

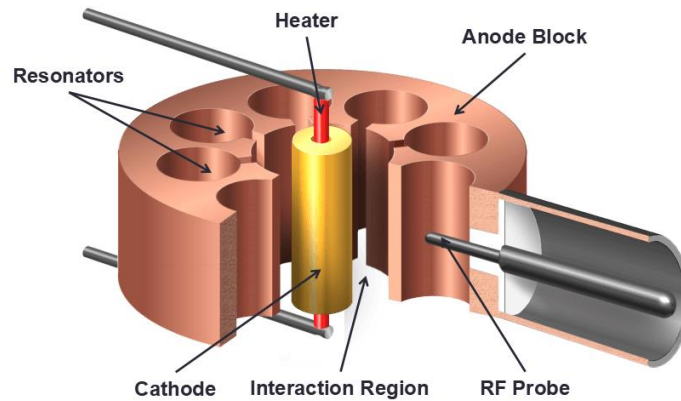

Figure 3.14 Magnetron Design model Used in Microwave Oven [46]

The main elements of magnetron are discussed below:

**3.4.2.1 Cathode:** Magnetron act as an active device because of this part. A cathode is positioned at the center of the anode. It finds use in supplying electrons in order to make energy transfer effective. It contains emissive material cylinder surrounded by the heater. Electrons are emitted at a specific temperature and it works on the phenomenon of back bombardment.

**3.4.2.2 Anode:** A resonating cylindrical structure which includes numbers of anode block in order to spread innermost region is known as an anode of a magnetron. Resonant cavity is the opened part of the vane blocks that control the frequency produced in the magnetron. It acts as a tuned circuit due to the controlling of the frequency. Alternate segments are linked to each other by using straps so that each segment has opposite polarity, this is how an anode cavity works in a magnetron.

#### 3.4.2.2.1 Types of Anode Cavity

The magnetron design is established by its anode. Generally, an anode is formed by setting multiple resonant cavities in a circular direction as shown in Figure 3.15. The different types of anode structure are:

- 1) Vane-type
- 2) Hole and slot
- 3) Rising-sun

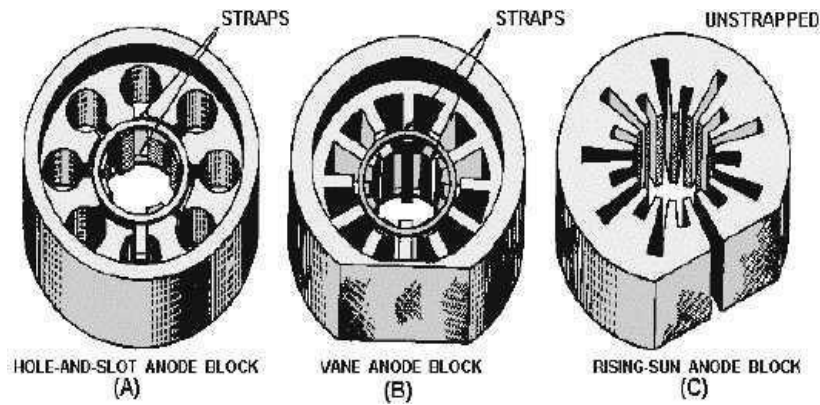

Figure 3.15: Different Types of Cavities Used in Magnetron [44]

**3.4.2.3 Straps:** The main function of the strap is to disconnect pi-mode frequency from other mode frequency. When compared to pi-mode, all the parts of the strapping ring have the same potential whereas 2 strapping rings should have opposite potential interchangeably. In case of other modes, phase difference is found among the continuous segments that are linked with each of the strapping rings.

**3.4.2.4 Heater:** It is also termed as filament head and provides the function of cathode. It is positioned in the magnetron's center. It is sealed in inflexible and large filament which is closed and protected.

**3.4.2.5 Antenna:** It is accompanied by a ring or probe, that is connected with one anode block. Waveguide which is a hollow metal is attached with an antenna that spreads Resonant-Frequency energy.

**3.4.2.6 Tuner:** The basic frequency obtained at an anode is diverged with the help of a tuner. This is divided into the following:

- 1) Inductive
- 2) Capacitive
- 3) Combination of both

**3.4.2.7 Magnetic Circuit:** The magnetic circuit associated with magnetron is used to provide cross-field action in order to deliver the required trajectory of an electron. The magnetic circuit up to this point consists of the outer stable magnet along with interior pole pieces. The main application of the magnetic field is to provide a stable and strong magnet which provides stable magnetism near the magnetron along the cathode's axis.

**3.4.2.8 Output:** The output produced at resonator circuit of magnetron by making coupling with external load. The radio frequency (RF) energy is obtained from the cavity or coaxial or waveguide.

### 3.4.3 Cylindrical Magnetron Operation

The conventional magnetron is also known as a cylindrical magnetron. Figure 3.16 depicts a schematic diagram of a conventional magnetron. For fabrication of magnetron's anode, a cylindrical copper block is used. Many reentrant cavities have been connected with the gaps [21]. The cathode consists of filament structure which is spiral in shape and cathode is placed to the center of device with the support of filament leads as shown in Figure 3.16. Anode and cathode gap combine together to form resonant cavities, this gap determines the different possible mode of frequency. The interaction space is defined as the space between cathode and anode. The electron when enters this space experience force due to the presence of a magnetic and electrical field. Loop or probe acts as output lead which extends in one of the tuned cavities and coupled into a waveguide [47].

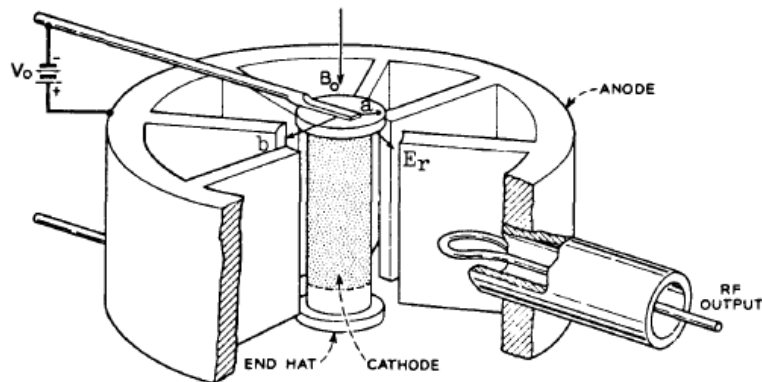

Figure 3.16: Schematic Diagram of a Cylindrical Magnetron [48]

The emission of an electron is the first stage which occurs when DC voltage  $V_0$  is applied along anode and cathode. Generally, in magnetron the cathode is kept at negative potential and anode is set at ground potential. Under the influence of magnetic and electrical field, there is the formation of electron cloud across the cathode. The electron cloud formation is followed by electron spokes that are influenced by the RF field. At the end transfer of energy occurs between RF field and electron spokes and the oscillation of RF power grows up to the saturation limit. The oscillations will nonstop till the magnetron power is down.

For better understanding, consider the motion of a single electron. Lorentz force has been described in the Equation 3.1. Lorentz force governs the motion of an electron in the interaction region.

$$\vec{F} = q\vec{E} + q(\vec{v} \times \vec{B}) \quad 3.1$$

Figure 3.17 represents the rotation of an electron. There are 2 types of rotation for the electron. One with radius  $r_0$  (Fast rotation) and other with radius  $R_0$  (slow rotation). The combined rotation of electron is known as electron trace [49].

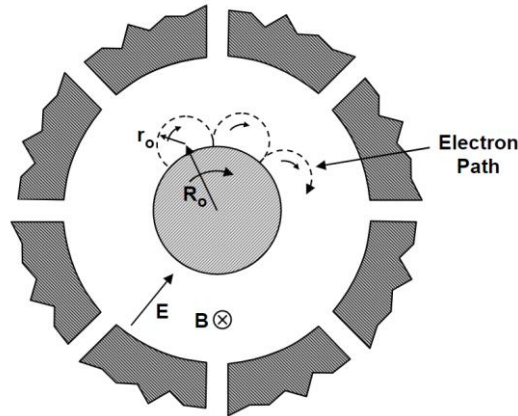

Figure 3.17: Electron's Path Under Lorentz Force [49]

Now, considered all electrons at a time they form 2 type of steady-state streams. Brillouin stream (single stream state) includes the orbit around the cathode whereas, double stream state consists of the intersection of anode with cathode [50]. The streams of electrons result in the formation of electron cloud as shown in Figure 3.18.

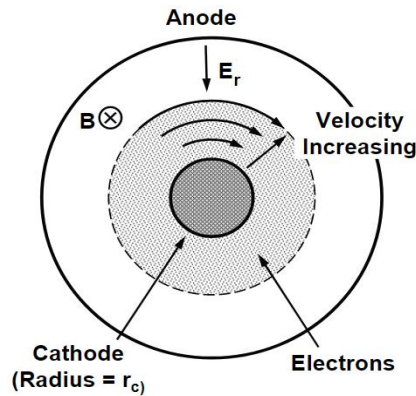

Figure 3.18: Setup of Electron Cloud in Case of Magnetron [49]

Drift velocity is the speed with which the electrons rotated under the presence of the magnetic and electrical field given in Equation 3.2. There is some thickness of cloud in which electron rotates with drift velocity.

$$\vec{v}_d = \frac{\vec{E} \times \vec{B}}{|B|^2} \quad 3.2$$

Because of the presence of diamagnetic effect, electron cloud, magnetic field and electrical field changes from cloud thickness to the cathode. This change is dependent on the increase distance from cathode and it also changes the drift velocity. The presence of electron velocity

and electron density causes the production of the noise component in the rotating electron clouds. This noise comes under the category of white noise and covers the range of infinite frequency [49]. This is the main cause for the creation of force which leads to the RF oscillation in magnetron's cavity. Cavity possesses the characteristics of bandpass filter therefore, the frequency supported by the cavity will grow up. The Rf field generated in the cavity interacts with interspatial electron cloud. Figure 3.19 shows the electron cloud interaction with the RF field.

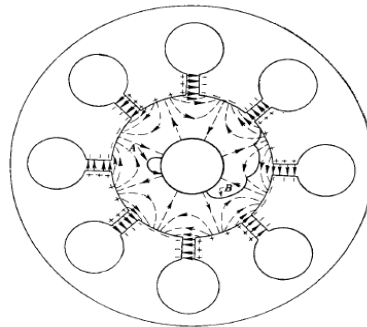

Figure 3.19: Interaction of Electron and RF Field in the Cathode and Anode Gap [45]

The electrons rotation is promoted by the presence of an electric field as shown in Figure 3.19. Hence there is an acceleration in the electrons and also increment in the velocity. This increased velocity leads to bending the electron path because of the Lorentz force created by the DC field, as a result, it is directed towards the cathode. Whereas RF electric field opposes rotation of electron causes the deceleration of electron. After deceleration electron come near to the anode [45]. These interaction leads to the formation of spokes as shown in Figure 3.20. Due to the oscillation in the RF field, spokes with drift velocity revolves around the cathode. The rotations of cloud and RF field gets synchronized and at this state the drift velocity and phase velocity become equal.

Electrons that are decelerated transfer their energy to RF oscillation. This leads to the increase in the oscillation till saturation of their power. This transfer of power is continuous throughout the operation of magnetron.

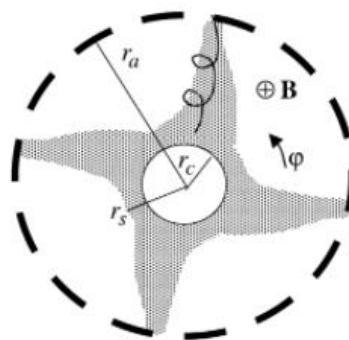

Figure 3.20: Electron Spokes [50]

### 3.4.3.1 Effect of Magnetic and Electric Fields

The emission of electron from the cathode is depends upon the electric and magnetic field. These free electron travels towards the anode cavity with a circular motion. Figure 3.21 shows the different electron paths because of the variation in the magnetic field. In the absence of a magnetic field, the electrons get deflected and travel to the anode as per the blue trace.

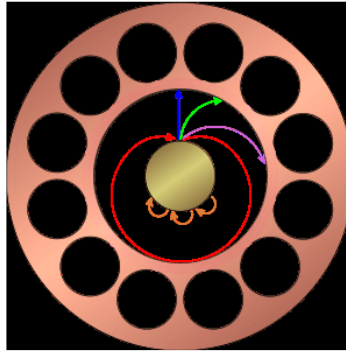

Figure 3.21: Path of Electron According to Various Magnetic Fields [46]

The electron is deflected in the interaction space as per the magnetic field is shown in the green trace. As the B- field strength grows, the anode is touched by the electrons as shown in the red trace. The point is called as Hull cut-off point.

### 3.4.3.2 Hull or Hartee Condition

For proper functioning of magnetron, magnetic field and anode voltage satisfies some special conditions. In cylindrical magnetron, condition for an electron to touch the anode is called Hull cut off condition given in Equation 3.3 [22]

$$V_h = \frac{e}{8m} B^2 r_a^2 \left(1 - \frac{r_c^2}{r_a^2}\right)^2 \quad 3.3$$

The minimum amount of magnetic field that is required for a given geometry at a particular electron voltage is obtained from Hull Cut-off condition. Hartee and Buneman relation is applied to obtain the maximum magnetic field value [20], [23].

In the presence of the magnetic field with no RF field and anode–cathode voltage is less than  $V_h$  then the electron is not able to reach the anode. This voltage  $V_h$  is known as Hull Voltage or the cutoff voltage. In case, a magnetron is operated less than cutoff voltage, the hub or electron cloud will be formed among anode and cathode. For magnetron to initiate the oscillation, a necessary requirement is that electrons should synchronously rotate in the RF field in order to satisfy the Equation 3.4

$$\omega_e = \frac{\omega}{n} \quad 3.4$$

Applying this synchronous condition to the equation of electron motion:

$$\frac{d^2r}{dt^2} - r \left( \frac{d\varphi}{dt} \right)^2 = \frac{e}{m} E_r - \frac{e}{m} r B_z \frac{d\varphi}{dt} \quad 3.5$$

$$\frac{1}{r} \frac{d}{dt} \left( r^2 \frac{d\varphi}{dt} \right) = \frac{e}{m} B_z \frac{dr}{dt} \quad 3.6$$

Equation 3.5 and Equation 3.6 governs the motion of an electron in terms of cylindrical coordinates, here  $\varphi$  = angle taken in cylindrical coordinates. To obtain the threshold voltage form RF oscillation that occurs in a magnetron is obtained from Equation 3.7

$$V_t = \frac{r_a^2}{2} \left( 1 - \frac{r_c^2}{r_a^2} \right) \frac{\omega}{n} B_z - \frac{r_a^2}{2} \frac{m}{e} \left( \frac{\omega}{n} \right)^2 \quad 3.7$$

Hartree voltage is also called a threshold voltage. At threshold voltage, B is enough such that the figured charge space does not expand to the anode also the oscillation starts at threshold voltage. In case of uniform magnetic field, the electrons accelerate in the interaction region. These particles rotate around the cathode. If the electromagnetic mode's phase velocity is equal to the azimuthal velocity of particles then there is a probability to exchange energy in between the mode and particle. This condition is called Buneman-Hartree resonance [24]. The Hartree Threshold Voltage is shown in Figure 3.22, the curve is for 8 cavity magnetron. In case anode voltage is above Hartree voltage curve, then oscillation starts in the magnetron. Generally, to stave off the mode competition, anode and cathode voltage are set below  $\pi$ -1 mode line ( $n = 3$ ) as shown in Figure 3.22.

### 3.4.3.3 Equivalent Circuit and Oscillation Modes

It is important to design the resonant system properly while designing a magnetron. There is an endless number of resonant frequency available in the magnetron. By determining the operation frequency stable operation magnetron is made possible. The stable operation determines the stability against frequency jumps for different modes and small variation in frequency [52].



difference is equal. The voltage for each anode cavity is mentioned below [45].

$$V_1 = V_m \sin(\omega_o t) \quad 3.8$$

$$V_2 = V_m \sin(\omega_o t - \varphi) \quad 3.9$$

$$V_3 = V_m \sin(\omega_o t - 2\varphi) \quad 3.10$$

.....

$$V_8 = V_m \sin(\omega_o t - 7\varphi) \quad 3.11$$

$$V_9 = V_m \sin(\omega_o t - 8\varphi) \quad 3.12$$

It is 8 cavity magnetron hence  $V_9$  should equal to  $V_1$  because the magnetron is a close unit. Therefore,  $8\varphi = 2\pi n$  where  $n = 0,1,2,\dots$ . Considering  $N$  Number of resonating cavities, the condition for oscillation is given by

$$N\varphi = 2\pi n \quad 3.13$$

Adjacent cavity phase shift can be given by equation 3.14

$$\varphi = 2\pi n / N \quad 3.14$$

here  $n$  represents the mode of oscillation and it should be an integer. Figure 3.24 represents the dispersion diagram. It relates the phase shift to the operating frequency. The upper curve shown in the figure represents the higher mode order whereas lower curve represents the lowest mode order.

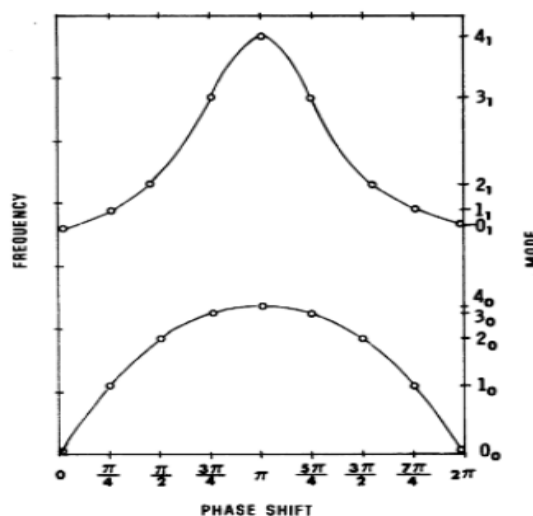

Figure 3.24: Dispersion Diagram Representing 8 Cavity Magnetron [53]

Equation 3.15 relates the operation frequency for a particulate mode with the cavity radial size.

$$f_{\pi} = \frac{c}{4(r_v - r_a)} \quad 3.15$$

From the Equation 3.15 it is inferred that the frequency of magnetron and cavity size are inversely related. In the designing process, this equation is used for frequency determination. To know the effect on frequency due to axial mode equation 3.16 is used as shown below,

$$(f_n^g)^2 = (f_n^o)^2 + \left(\frac{gc}{4h}\right)^2 \quad 3.16$$

While designing a magnetron it is desired to keep the low axial length. Because of a decrease in mode separation and increase in cavity axial length, there is a reduction in the second term of the equation. This may lead to mode competition.

For making the oscillation in the device, the magnetic field and DC voltage should be regulated in such a way so that the electron's average rotational velocity should be equal to slow wave field phase velocity.

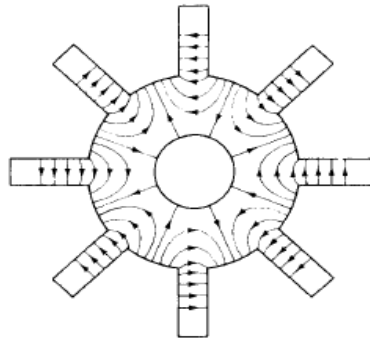

Figure 3.25: Lines of Force For 8 Cavity Magnetron in  $\pi$ -Mode [45]

Generally, magnetron works in  $\pi$  mode oscillations. In  $\pi$  mode, cavities have opposite phases and have large excitation. Figure 3.25 represents the line of force for 8 cavity magnetron in  $\pi$  mode. A wave travelling along the surface of slow wave structure shows the fall and rise of the field in the anode cavity [48].

### 3.4.4 Magnetron Applications

Magnetron finds the application mostly in the pathway or monitors supersonic missiles, aircraft detecting system, tracking and observing of weather patterns, garage door openers, air traffic control (ATC), police speed detector system, microwave oven, industrial heating etc. In microwave oven and industrial heating, continuous wave type magnetron is used. Some

applications of magnetron are described below:

- 1) **Air Traffic Control:** The main objective of ATC is to reduce the air traffic, give knowledge about the collisions and provide supportive information to the pilots. Various types of bands, for example, S-Band, X-Band, Ku and Ka-band are used for ATC. It is also used for defence or security system especially for the military in some countries.
- 2) **Linear Accelerator (LINAC):** This system finds the application for cancer tissue determination in external beam radiation treatment. It finds application in the treatment of all the organs of the human body. The functioning is based upon providing electrons or x-rays of high energy to the patient's tumor region. It is also used to destroy the cancer cell by modifying the electrons and X-ray. Volumetric Modulated Arc Therapy (VMAT), Intensity-Modulated Radiation Therapy (IMRT), Image Guided Radiation Therapy (IGRT), Stereotactic Body Radio Therapy (SBRT) and Stereotactic Radiosurgery (SRS) are areas where magnetron can be used. X-Band, S-Band and C-Band magnetron are used in case of medical linear accelerator application and safety screening.
- 3) **Frequency Agile:** X-Band, C-Band, Ku and Ka-Band frequency agile magnetron finds application in mid-air fire control, electronics fighting and searcher radar.
- 4) **Weather Radar:** It is also named as Doppler weather radar (DWR) and weather surveillance radar (WSR). It finds application in the field of analysis of motion, location observation and prediction of weather for example rain, hail, snowfall etc. The modern DWR has the potential to detect raindrop's motion. C-Band, S-Band and X-band magnetron finds application in weather detection as a pulse Doppler radar. It also gives information regarding navigation and weather.
- 5) **Beacon Transponder:** X- band, C-Band and Ku Band beacon magnetron uses in ACLS, transponder, UAV and transportable radar application. For air traffic-control system secondary surveillance radars are used. The air traffic separation and surveillance radar monitoring system can be implemented by using Modern Air Traffic Control Radar Beacon System (ATCRBS).
- 6) **Air Traffic Control Radar Beacon System (ATCRBS):** Corporative equipment within the style of radar transmitter/receiver (Transponder) can be detected by the radar system. Transponder transfer the radar signals and interrogator receives the signals. A transponder in the corporative equipment helps to trigger the particular transmission. For the further

display and processing, transmission signal received by the air-traffic-control facility. This one permits to examine the specific data of aircraft like beacon code, altitude and ground speed etc.

**Problems with ATCRBS:** The interrogation has been done by using a rotating antenna. Up to 20 times an aircraft interrogated per sweep. Every time a different reply is sent by the transponder which results in overload and interference in channels. Once's the interference occurs, disconnected signals are received by the ground stations. Also, at a given time increase in air traffic results, the increase in the interrogation beam of antenna for the number of airplanes.

- 7) **Special Purpose:** CIED, EMV/EMC testing, technical-scientific and industrialized application use a different type of bands such as C-Band, S-Band, Ku and Ka-Band and X-Band magnetrons.
- 8) **Magnetron and Microwave Oven Design:** RF power is used by magnetron for its high energy transformation potency. Later on, MGT developed as computerized engineering techniques, mass invention and radar machinery techniques have admittable MGT application in the area of home such as Microwave oven.

In MWO, the resonator's frequency crystal port is indicated toward the cooking compartment with the help of waveguide. It is vital to place food inside the oven while operating in micro mode (only MGT works) otherwise the RF wave reflecting inside the cavity and move back to the waveguide that results in arcing. Of this arcing is for more time then it may damage the MGT. Therefore, food has to be there in the cavity to absorbs the RF waves.

### 3.5 CST Particle Studio

It is advanced software used for the High-frequency range design along with electromagnetic analysis. This software is used for simplification of structure with the help of graphical modeling of solids based on ACIS kernel modeling. Before simulating the model, automatic meshing procedure is employed. This software consists of various technical simulation such as integral equation solver, frequency domain solver, multilayer solver, eigen mode solver, transient solver and asymptotic solver suited for different applications.

The simulation of the magnetron can be done by this software. It includes different solvers for the simulation such as particle tracking solver, Eigen mode solver and Particle in Cell (PIC) that are used in Particle studio. For the simulation of different aspects of magnetron, only one solver is used at a time [25] that is PIC.

### 3.5.1 Particle-In-Cell Simulation Technique

The motion of particles in plasma is simulated by using the PIC solver program. It analyses the velocity and position of the particle and compute the macroparticle quantities same in a manner to distribution function, current density, density. The force on particle is determined by using the field equation and a mesh cell is used in which all the particles are placed. Maxwell's equations and the dimension of the code are used for the PIC solver mode. The broad set of Maxwell's equation has been resolved by the electromagnetic program whereas electrostatic programs solved only the Poisson equations.

The early work of Dawson and Buneman implemented the collision less plasma simulation using PIC. It includes the space charge forces with Coulomb's law explanation and periodical structures of charged particles will be calculated.

In recent time, PIC program is simulated with 10<sup>5</sup>-10<sup>10</sup> particles earlier it was 10<sup>2</sup>- 10<sup>3</sup> particles. PIC has many advantages such as it represents the lowermost program means that the expectations reduced to the minimum number for the physical model. This stimulates complex plasma and atomic surface interactions, difficult geometries, and higher dimensional cases. The computational efficiency and long processing time are declared to be a disadvantage of the technique.

Implementation of simulation by CST PIC and CST MS helps in receive device's domain frequency. The important values for the design of structure which includes the radius of anode, cathode and electron's relative velocity. Initially, Eigen mode simulation is performed to achieve the coupled cavities Eigen mode value. Large excitation with the opposite phase of adjacent cavities is achieved in  $\pi$ -mode operation. The alternate decrease and increase of adjacent mode are regarded as a traveling wave that is along with the slow wave structure. Generally, magnetron operates in oscillation when in  $\pi$ -mode.

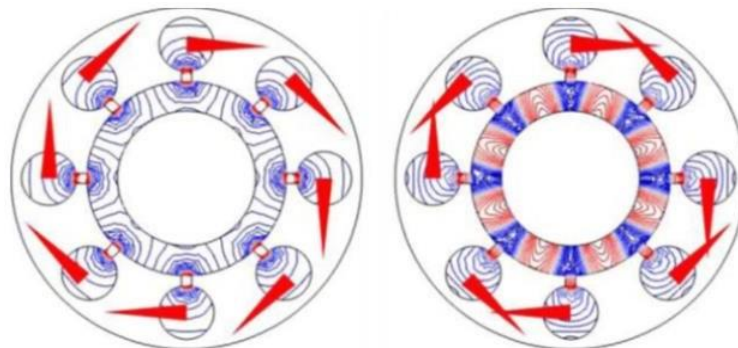

Figure 3.26: Magnetron With  $\pi$ -Mode (At Right Side) And  $2\pi$ -Mode (At Left Side) [51].

Many modes achieved for the process of the magnetron in which  $\pi$ -mode with GHz frequency selected because this is the frequency which is non-degenerate. The white frequency signal is

produced due to the alternation in the emission process. The electric field distribution as  $\pi$ -mode in the cavity is shown in Figure 3.26. the suitable frequency has been selected by the cavity from the noise frequencies that have eigen modes of the total cavity [22].

Simulation in PIC supports the output of magnetron by simulating the interaction performance of electron beam with Resonant-Frequency circuit. The sharing of field power density by the resonant modes is the output of the simulation.

The simulation is used to find the output of field power density related to resonating modes of operation which is along magnetron's transversal cross-section [51].

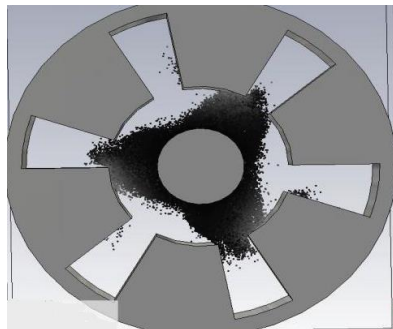

Figure 3.27: 6- Coupled Cavity Electron Spoke in  $\pi$ -Mode

The electrons released in the interaction space forms the shape of the cloud and starts moving mutually as shown in Figure 3.27. For the simulation of magnetron technologically advanced software is used called a Particle studio. The different solvers used for simulation are: particle tracking solver, Eigen mode solver and Particle in Cell (PIC) that are used in Particle studio. For the simulation of different aspects of magnetron, only one solver is used at a time [25].

### 3.6 HV Supply for Microwave Generator

The supply for the microwave generator is shown in Figure 3.28. This supply includes a leakage flux transformer, capacitor, and diode cell, which stabilize the current and double the voltage [26]. The conventional power transformer theory doesn't apply to this transformer because of the presence of shunts. The flux leakage through a transformer with shunt is of the same order as that of conventional one. An additional advantage of this transformer is stabilization of the magnetron anode current due to the magnetic saturation circuit. There is numerous literature available related to the modelling of conventional transformer [27] [28], but study focusing on a transformer with shunt is rare.



To obtain the value of  $(\Phi, i)$  using the B-H curve and geometrical parameter of the inductances, specific routine has been elaborated in MATLAB. The implementation of each nonlinear inductance is represented by a block diagram as shown in Figure 3.31.

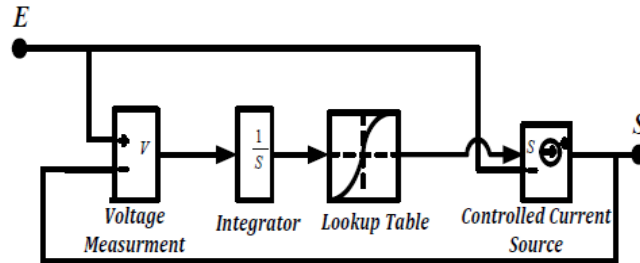

Figure 3.31: Block Diagram of Non-Linear Inductance

The components used for the designing of non-linear inductance are integrator, voltmeter, controlled current source and Lookup table (LUT) that define the input-output relations. Working of each block is described as; flux values are deduced using integrator block from voltages. Look up table block is there which is used to find the output value as per the input values. Basically, it defines the input and output relation which will be defined by the user. Here  $(i, \Phi)$  values are deduced from those  $(H, B)$  values. It also contains a controlled current source [36], [37].

## TEST ON MICROWAVE OVEN AS PER IEC 60705

## 4.1 Determination of Microwave Power Output

## 4.1.1 General Test Condition

- 1) The ambient temperature must be  $23^{\circ}\text{C} \pm 2^{\circ}\text{C}$ .
- 2) The supply voltage shall be lie in  $\pm 1\%$ . Range of rated voltage
- 3) Oven with parts (Supply & MGT) should be within  $2^{\circ}\text{C}$  of ambient temperature.
- 4) Water with  $10^{\circ}\text{C} \pm 1^{\circ}\text{C}$ , the initial temperature should be used for the test.
- 5) Borosilicate glass cylindrical container is used with a height of approximately 90mm and external diameter of 190mm approximately.
- 6) Amount of water  $1000\text{g} \pm 5\text{g}$  should be used.
- 7) The position of the appliances are away from the sidewalls and there back should be in front of the wall.
- 8) The thermocouple should be used for the temperature reading. Power meter should be used for the power and Energy readings as shown in Figure 4.1.

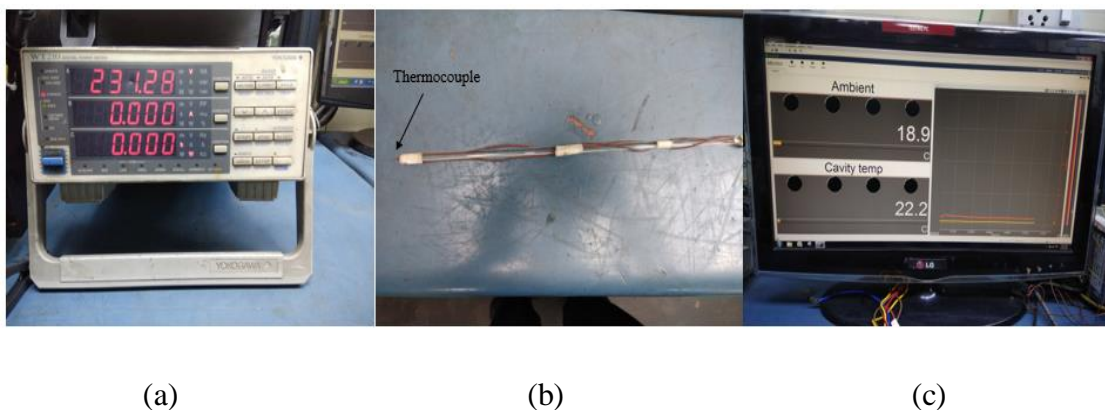

Figure 4.1: (a) Power Meter; (b) Thermocouple; (c) Ambient and Cavity Temperature Reading on Testing PC

## 4.1.2 Test Method

Glass container filled with water is used for the test purpose. The temperature of the water is raised to ambient temperature from the initial temperature that was below from ambient

temperature by using microwave oven heating. In this process, it should ensure that there should be minimum heat loss otherwise a correction factor has to be introduced. It is important to measured water temperature accurately.

The microwave power output is calculated from Equation 4.1 & Equation 4.2

$$P = \frac{4.187 \times m_w(T_1 - T_0) + 0.55 \times m_c(T_1 - T_A)}{t} \quad 4.1$$

$$\eta = 100 \frac{P \times t}{W_{in}} \quad 4.2$$

Figure 4.2 shows the borosilicate glass container with a cylindrical shape frame. It has an approximate height of 90mm with an external diameter 190mm. The mass of the container is 410g [38].

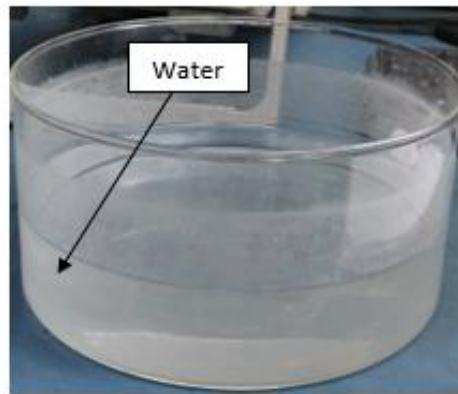

Figure 4.2: Cylindrical Container

At the starting of the test, empty container and oven are maintained at ambient temperature. Initial temperature of water should lie in  $10^\circ\text{C} \pm 1^\circ\text{C}$  range. Before pouring of water into the container, water temperature is measured.

1000g  $\pm$  5g quantity of water is used in the container and actual mass is measured. Start the oven and note the time to reach water temperature  $20^\circ\text{C} \pm 2^\circ\text{C}$ . Switch off the oven and measure the water temperature within the 60s. While measuring water temperature, it should be stirred with the low heat capacity stirrer. The experimental arrangement for the system is shown in Figure 4.3.

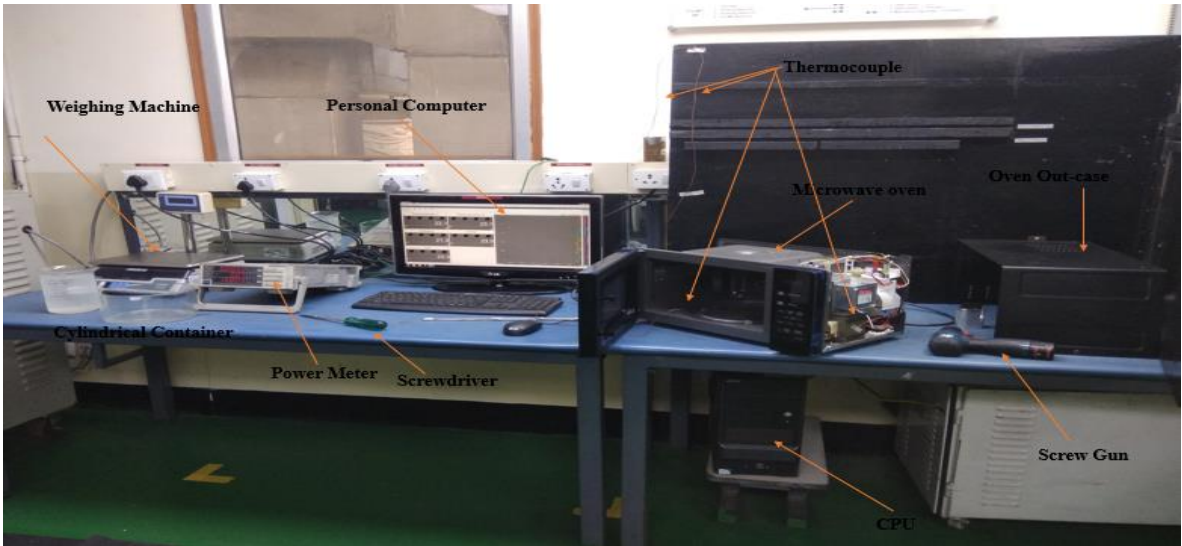

Figure 4.3: Experimental Arrangement for the Testing of Microwave Oven

### 5.1 Proposed Work Flow/ Methodology

As per the IEC 60705, efficiency of the microwave oven is calculated by using an Equation 4.2. Hence the efficiency of MWO majorly depends upon 'P' and ' $W_{in}$ '. For enhancement of efficiency, the ratio of P and  $W_{in}$  has to be increased. This could be possible by increasing the microwave absorption by the load i.e. food material presents inside the cavity. Hence it is required to reduce the losses or increase the number of waves that are produced by the magnetron. This can be achieved by the interaction of the electron with the RF wave as shown in Figure 5.1. In this figure, traveling wave and electrons are experiencing constant electric field in the azimuthal direction. The parameters of the cavity should be selected in such a way so that the cavity provides velocity of electron equal to the phase velocity of the traveling wave. In the accelerating electric field, the electron moves toward the cathode side whereas moving the opposite side in case of deaccelerating field. The electron that gives energy to the wave is known as favourable-phase electrons and those take energy from the wave are known as unfavourable phase electron. These unfavourable electrons take energy from the wave and move toward the cathode side.

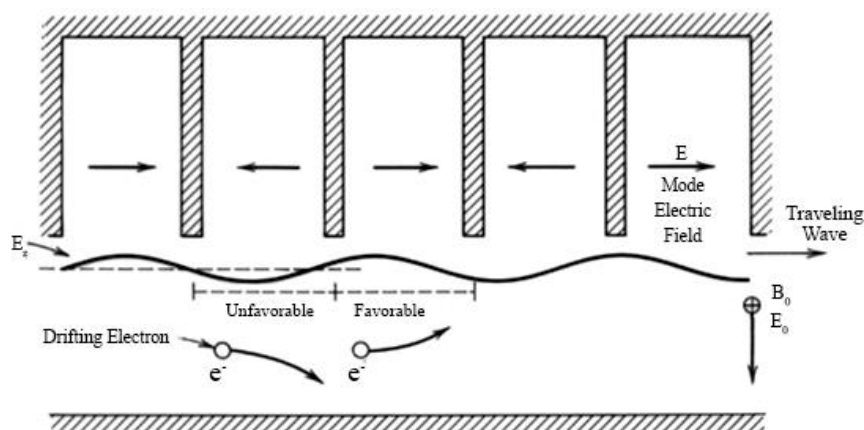

Figure 5.1: Mechanism for Resonant Drifting Electrons Interaction with a Traveling Wave

More energy is giving by the drifting beam to the wave because of the radial displacement of the electron. The electron that is favorable to the wave is drifted outward and they make spokes until they reached to the anode.  $N/2$  spokes are there in the B mode. The energy present in the unfavorable electron is not wasted. These electrons strike with the cathode and help them to heat. For high conversion of energy, most of the potential energy present in the electron should give to the microwave fields during gap crossing or it can be said that kinetic

energy of electron will be less when they reach the anode. The rough criteria for the same are given by Equation 5.1

$$\frac{m_e v_a^2 / 2}{e V_o} = \left( \frac{B_H}{B_o} \right)^2 \frac{[1 - (r_c / r_a)^2]^2}{16 [\ln(r_a / r_c)]^2} \quad 5.1$$

As magnetron generally operated well above the Hull cut off condition. Therefore, the factor present in the bracket is low in nature.

Now for more efficiency, there is a need to increase the number of favourable electrons. For those changes have to be done in the available magnetron. The change is shown in Figure 5.2

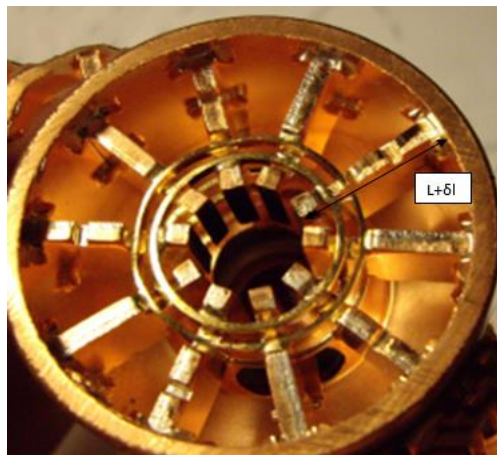

Figure 5.2: Magnetron Anode Vane

The optimum vane length has been found by simulating the magnetron for different vane length. CST STUDIO SUITE software is used for the simulation of the magnetron. CST studio is a solver module that analyses the motion of particles i.e. electrons in 3-D by using charged particles motion equations and Maxwell's equations. The particle in cell solver mode is used for the simulation of the magnetron at different vane length. It is also noted that by reducing the interaction space there is an increase in electric field and get an adverse effect on the motion of the electron. To maintain the Lorentz force and synchronization of the electron with RF wave there is need of intense magnetic field. Magnet with more field intensity has been considered for the same. An additional advantage of doing is the achievement of a uniform magnetic field inside the interaction space. Hence noise in the system reduces that enhances the power output of the magnetron. A magnetron with 10 cavities is used having anode radius 3.9 mm, cathode radius 1.9 mm and vane length of 8.29 mm. The magnetic field of 0.19 T is used in between the interaction region of the magnetron.

Due to the changes in the magnetron, impedance matching for the microwave oven gets disturbed. Hence there is a need to check the high voltage circuit parameters of the oven.

Also, it should be kept in mind while considering the high voltage circuit parameter that there should not be any abnormal condition occur while supplying to the magnetron.

The design and modelling of high voltage circuit has been done in Simulink software “MATLAB R2017a”. The Simulink model and the subsystems are shown in Figure 5.3, Figure 5.4 and Figure 5.5 respectively.

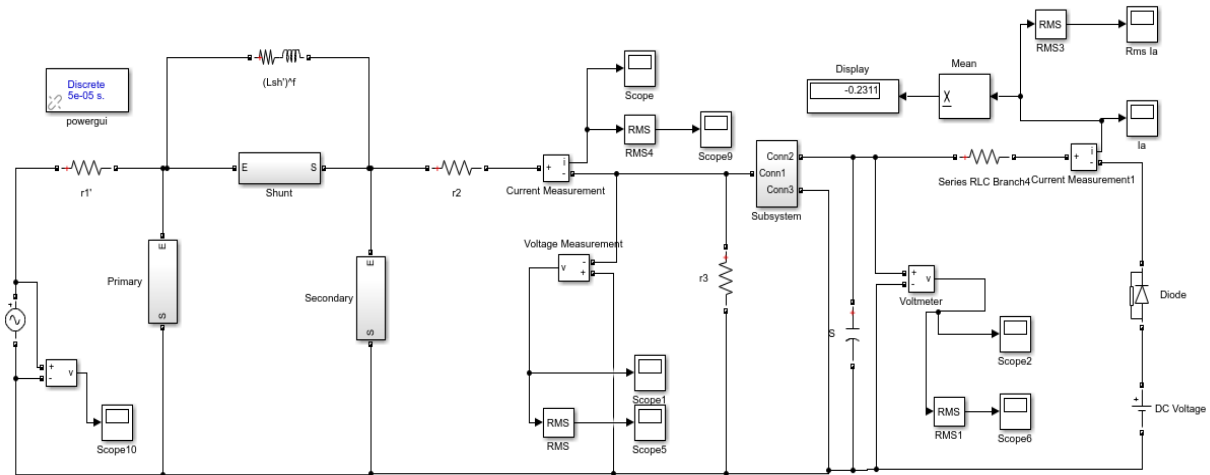

Figure 5.3: Simulink Model for High Voltage Supply for Magnetron

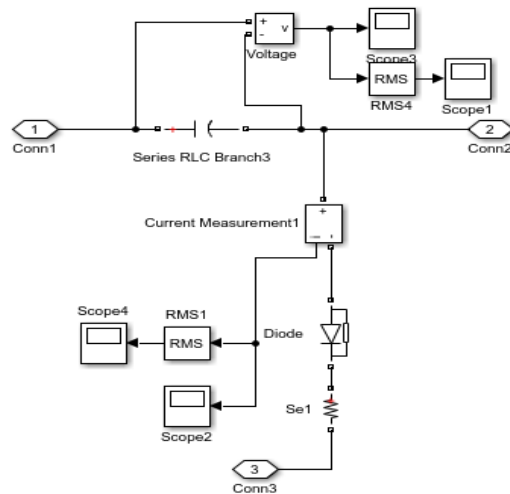

Figure 5.4: Simulation Circuit of Voltage Doubler Circuit

A voltage source is used to give supply to the  $\pi$  quadruple model of the non-linear transformer or single-phase leakage flux transformer. Further doubler circuit is used to enhance the voltage level as shown in Figure 5.4. The nonlinear inductance of the magnetic circuit is the function of the reluctance as shown in Figure 5.5.

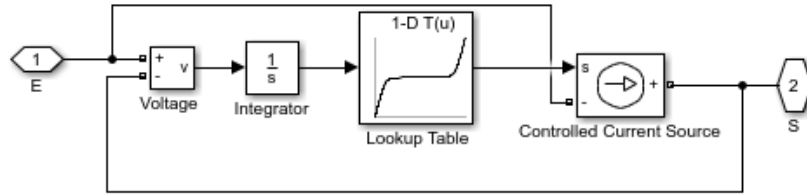

Figure 5.5: Simulation Circuit of Nonlinear Inductance

Nonlinear inductances have been calculated by using Equation 5.1 & Equation 5.2 [29][38] [39][40]

$$n_2 * \phi = n_2 * B * S \quad 5.1$$

$$i = (H * l) / n_2 \quad 5.2$$

B and H values are taken from the B-H curve of the material as shown in Figure 3.25. Using transformer geometrical parameters and B-H curve data, calculate flux and current values as shown in Figure 5.6 and Figure 5.7. 100 data values of  $\phi$  and  $i$  have been used for the lookup table.

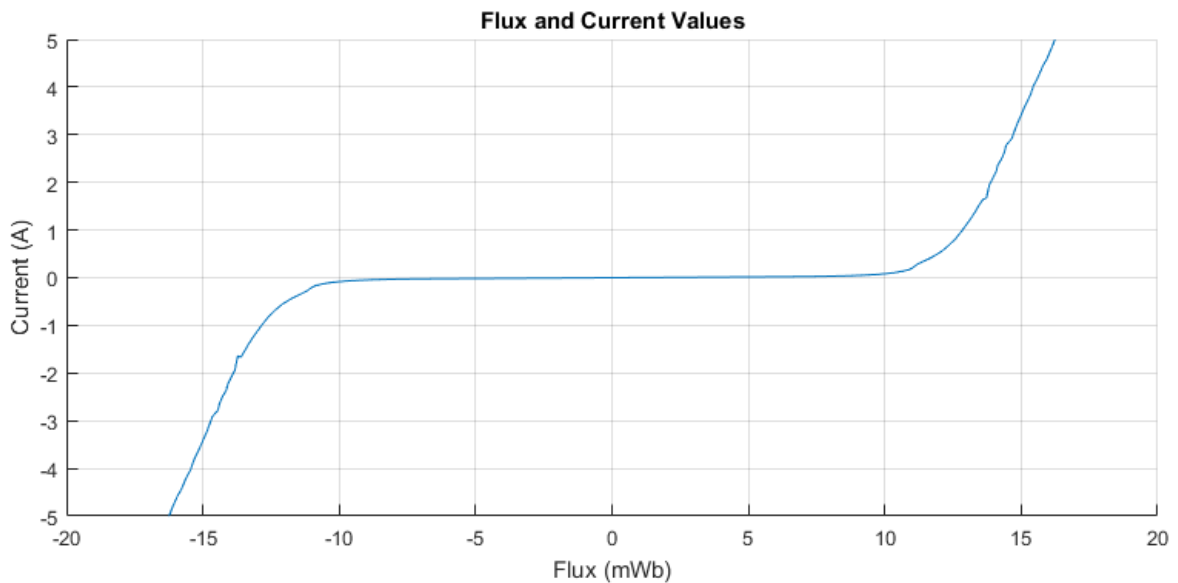

Figure 5.6: Flux Vs Current Curve of Primary and Secondary Side

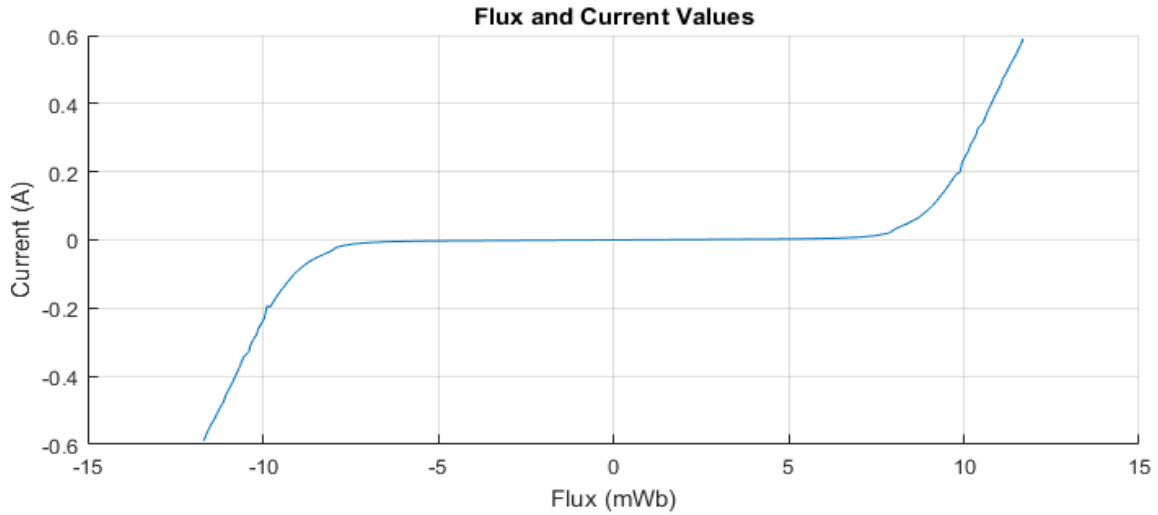

Figure 5.7: Flux Vs Current Curve of Shunt in HVT

Table 5.1 represents the specification of HVT. Different combination of HVT, HVC, and MGT further named as  $T_1$ ,  $T_2$  for HVT and  $C_1$ ,  $C_2$  and  $C_3$  for Capacitor and  $M_1$ ,  $M_2$  for MGT considers for the impedance matching.

Table 5.1: HVT Parameters

AC Voltage Source	Value		Unit
	$T_1$	$T_2$	
Peak voltage amplitude	3429	3197	V
Phase	-90	-90	Deg
Frequency	50	50	Hz
Sample time	0	0	-
<b>Secondary Side Parameter</b>			
$N_1$	248	238	Turns
$N_2$	2615	2340	Turns
$R_1'$	286.3	212	Ohm
$R_2$	191.3	173.5	Ohm
$(L'_{sh})^f$	3.453	3.453	Henry

This transformer output moves to the doubler circuit. Simulink model for the VDC is shown in Figure 5.4. Specification for Voltage doubler circuit is given in Table 5.2. Doubler circuit stabilize the current and doubles the voltage. These voltages will act as input to the magnetron.

Table 5.2: Voltage Doubler Circuit

Parameters	Values			Unit
	C <sub>1</sub>	C <sub>2</sub>	C <sub>3</sub>	
Capacitance	0.86	0.95	1	μF
<b>Diode</b>				
Resistance	0.0001			Ohms
Forward voltage	0.6			Volt
Snubber resistance	20000			Ohms
Snubber capacitance	5e-9			Farad
External resistance	16			Ohms

The magnetron is represented by its electrical equivalent as shown in Figure 5.3. Table 5.3 represents the electrical specifications of the microwave generator.

Table 5.3: Microwave generator Parameters

MGT Parameters	Value		Unit
	M <sub>1</sub>	M <sub>2</sub>	
Resistance	320	400	Ohms
<b>Diode</b>			
Resistance	0.0001		Ohms
Forward voltage	0.6		Volt
Snubber resistance	20000		Ohms
Snubber capacitance	5e-9		Farad
DC Voltage Source	-3800		Volt

### 6.1 Simulation Results

Simulation of electron distribution in interaction space has been done in CST PIC Environment. The cartesian coordinates system ( $x, y, z$ ) was used for this simulation to model the anode cross section. The 10-vane magnetron in the  $x$ - $y$  plane are shown Figure 6.1. It shows the starting stage of electron distribution in between anode and cathode.

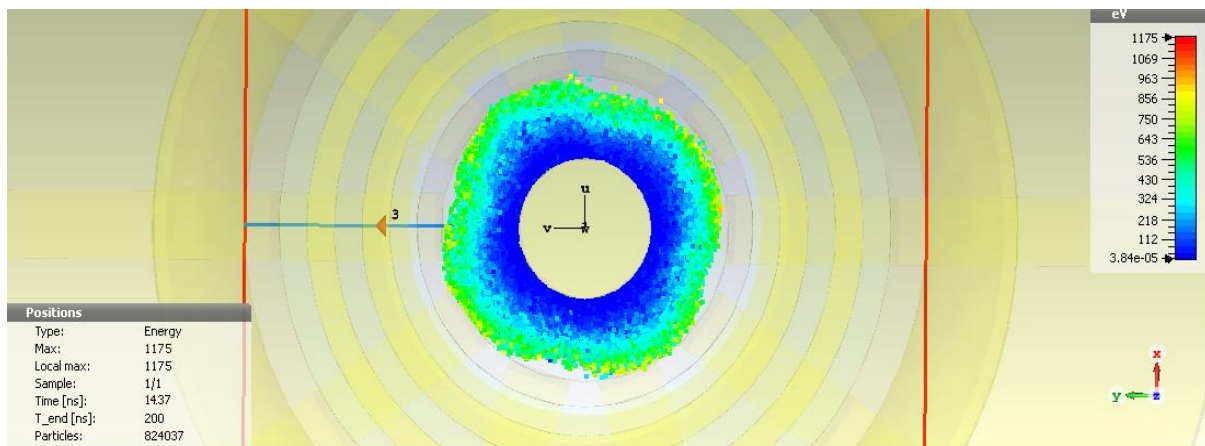

Figure 6.1: Electron Distribution at 14.37 ns

Further as times evolved, there is formation of electron spokes in between the interaction space of magnetron as shown in Figure 6.2.

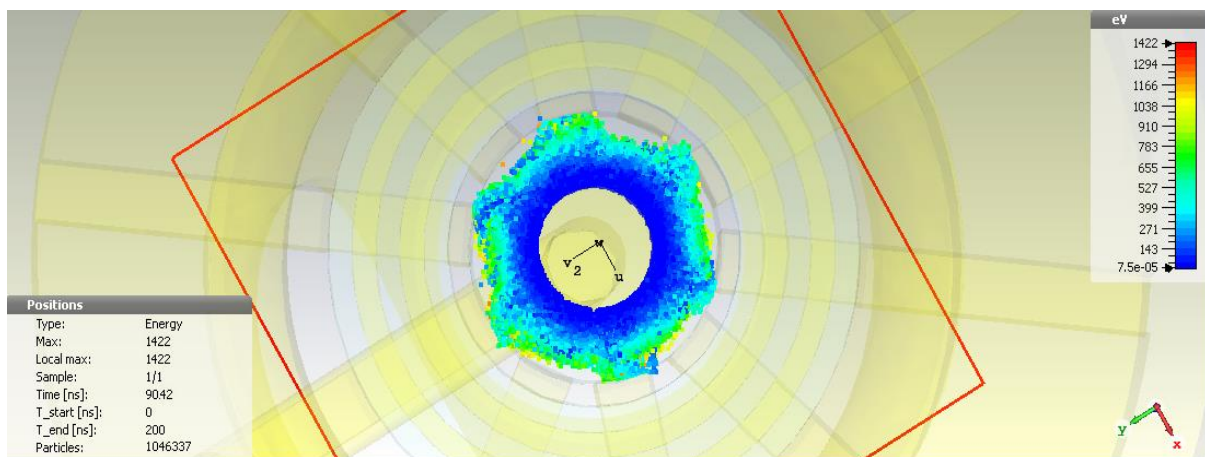

Figure 6.2: Spokes in Magnetron at 90.42 ns

As per the geometrical parameters of the magnetron, Figure 6.3 represent the fully formed electron spokes in interaction space. 5 spokes were formed that confirms the  $\pi$  mode oscillation.

Figure 6.3 and Figure 6.4 shows the comparison between the electron distribution of proposed and old magnetron. The proposed magnetron has concentrated distribution of

electron in comparison to old one. Also, the kinetic energy of electron reaches to anode is less in proposed magnetron.

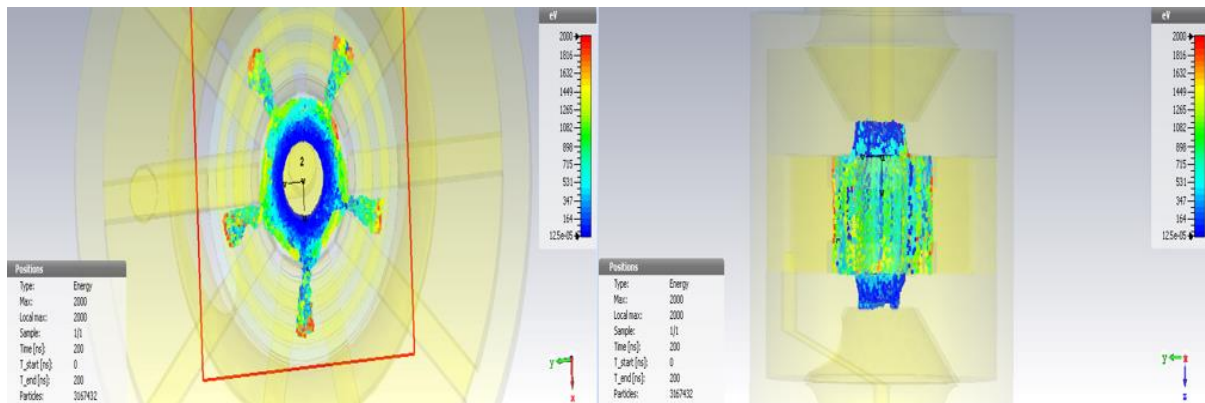

Figure 6.3: Particle Distribution in Old Magnetron

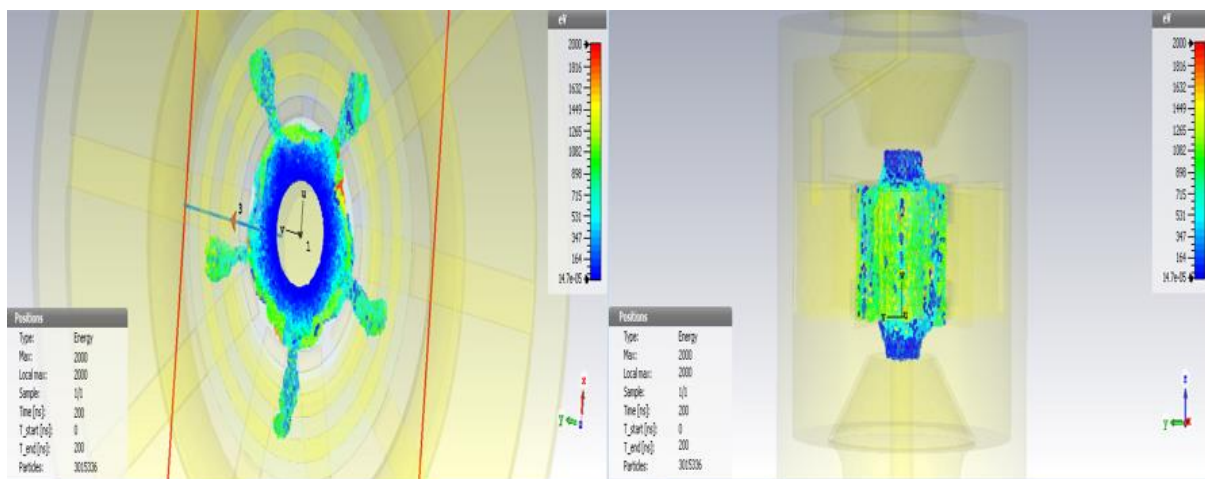

Figure 6.4: Particle Distribution in Proposed Magnetron

Figure 6.5 shows the output voltage vs time graph in which the amplitude of voltage increases and stabilizes in shorter period in the proposed magnetron.

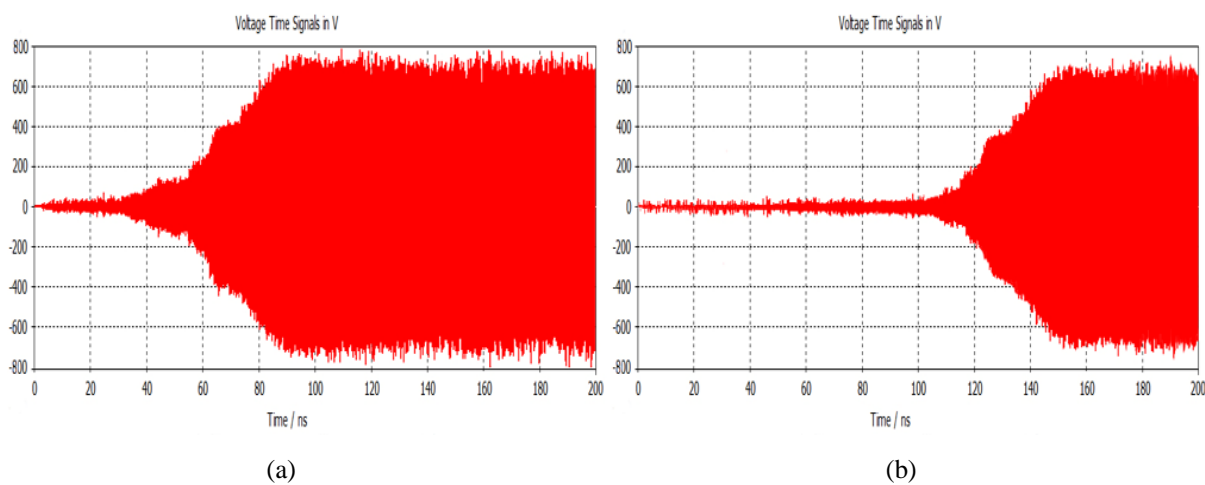
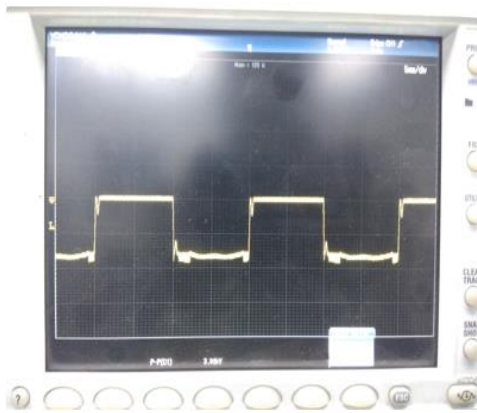
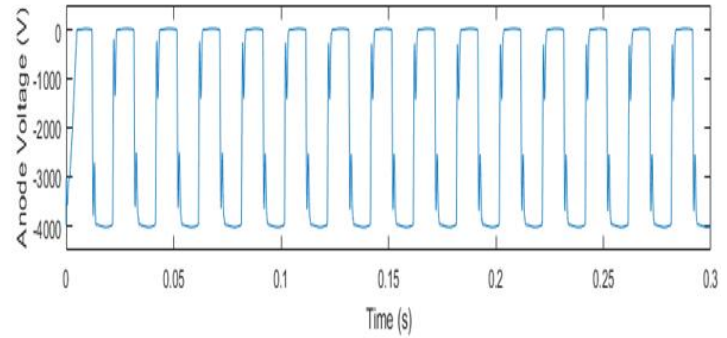

Figure 6.5: Evolution of Output Voltage with Time (a) Proposed Magnetron; (b) Old Magnetron

Magnetron output is dependent on the input supply as explained earlier. Corresponding to this, simulation of high voltage circuit has been done to find the matching of the impedance with the magnetron. The waveforms for the same are shown in Figure 6.6 to 6.11.



(a)



(b)

Figure 6.6: Anode Voltage for Case 1 (a) Experimental; (b) Simulated

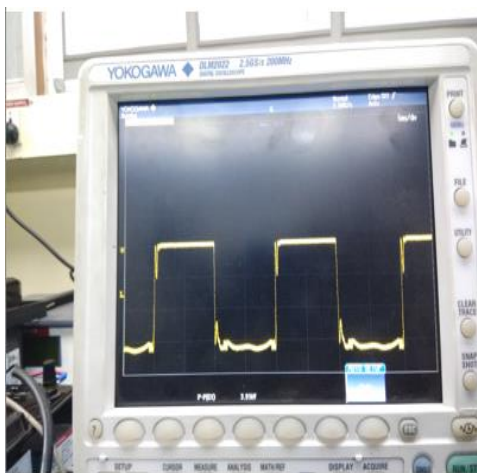

(a)

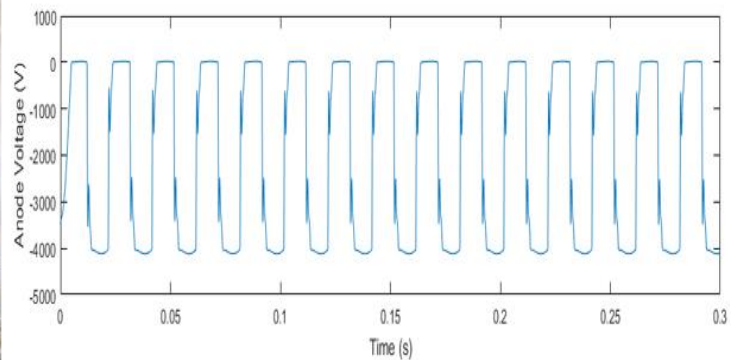

(b)

Figure 6.7: Anode Voltage for Case 2 (a) Experimental; (b) Simulated

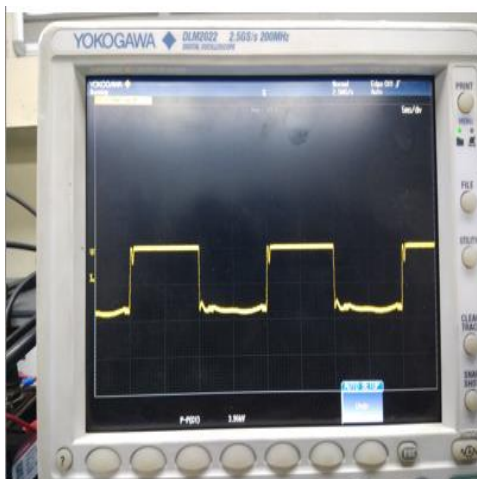

(a)

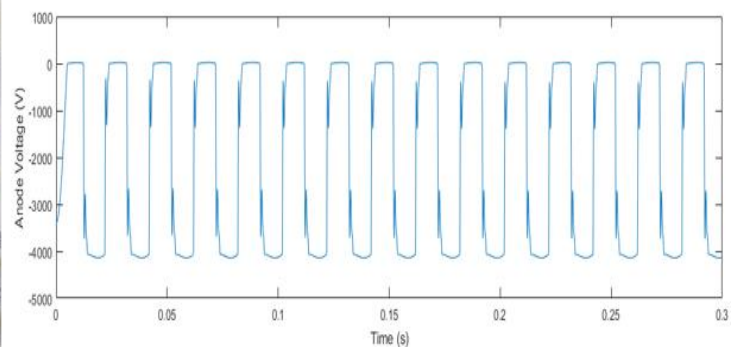

(b)

Figure 6.8: Anode Voltage for Case 3 (a) Experimental; (b) Simulated

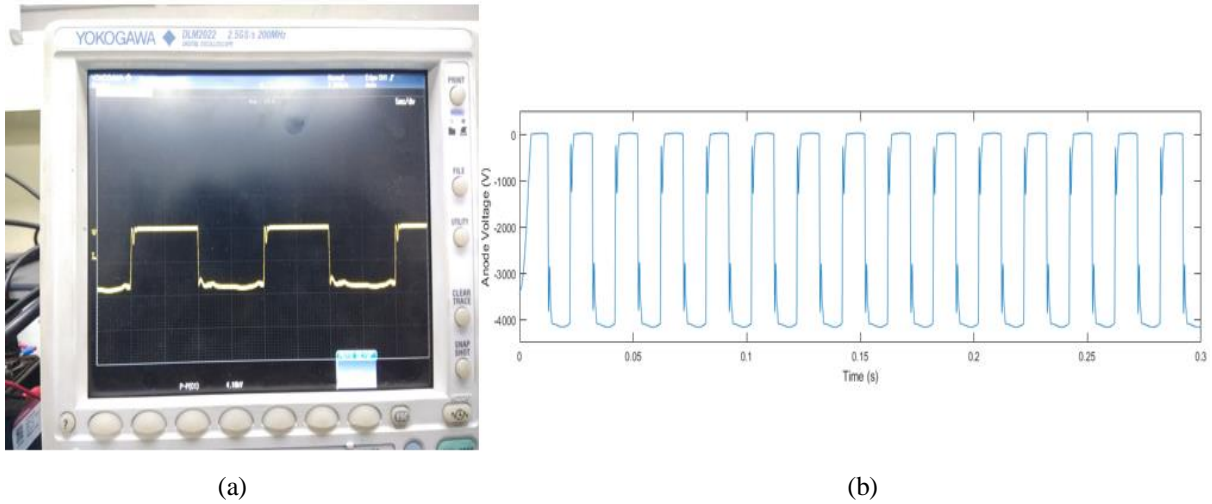

Figure 6.9: Anode Voltage for Case 4 (a) Experimental; (b) Simulated

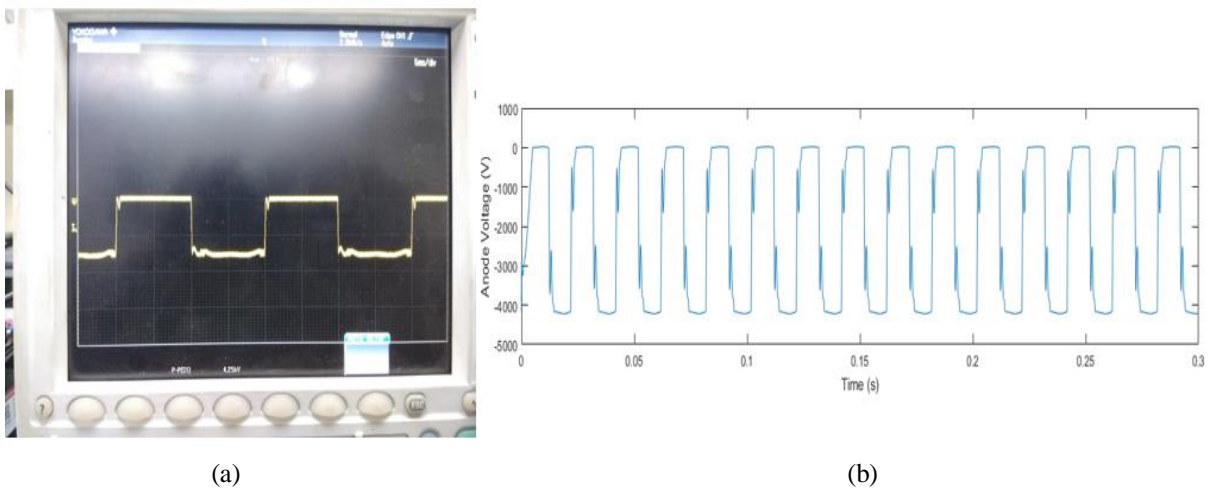

Figure 6.10: Anode Voltage for Case 5 (a) Experimental; (b) Simulated

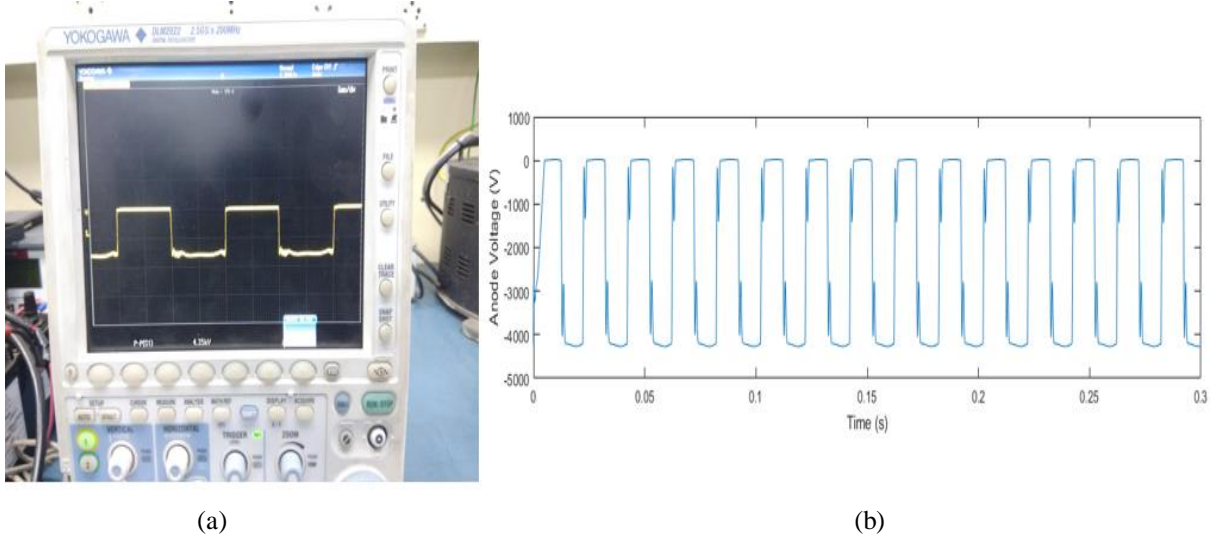

Figure 6.11: Anode Voltage for Case 6 (a) Experimental; (b) Simulated

The simulated and experimented values of voltage and current are compared and error is calculated as shown in Table 6.1.

Table 6.1 MGT Input Parameters Values

Case	HVT	Capacitor	MGT	Practical Values		Simulated values		(%) Error	
				Anode Voltage (V)	Anode Current (mA)	Anode Voltage (V)	Anode Current (mA)	Anode Voltage (V)	Anode Current (mA)
1	T1	C1	M1	3900	272	4010	273	2.82	0.368
2	T1	C1	M2	3910	270	4093	269.1	4.68	0.333
3	T1	C2	M2	3962	282	4124	287.6	4.088	1.986
4	T1	C3	M2	4106	295	4153	305.2	1.14	3.46
5	T2	C1	M2	4250	250	4210	241.8	0.94	3.28
6	T2	C3	M2	4350	280	4260	282.5	2.06	0.893

The error for the simulated and experimental voltage and current are less than 5 %. Table 2 represent the performance of the microwave oven.

Table 6.2 Performance of the MWO with Different Cases

S.no.	HVT	Capacitor	MGT	Power input (Watt)	Initial water temp. (°C)	Final water temp. (°C)	Power output (Watt)	Efficiency (%)
1	T1	C1	M1	1275	10.9	19.5	682	53.4
2	T1	C1	M2	1318	9.9	19	719	54.6
3	T1	C2	M2	1450	10.1	19.7	762.1	52.7
4	T1	C3	M2	1510	10.1	20.3	813	53.8
5	T2	C1	M2	1190	10.3	18.3	628.5	52.8
6	T2	C3	M2	1370	9.9	19.9	794	57.9

The Microwave Oven was operated for 52 sec in each case. The efficiency of the microwave oven is higher for the desired system i.e. 57.9% and it is approximately 4.5% more than the running case.

## 6.2 Discussions/ Inferences Drawn

The improvement in the style of the living culture of consumer encourages them to use the smaller kitchen or modular kitchens. Therefore, for efficient use of space, smaller kitchen appliances demand increases. A microwave oven is one of them. Nevertheless, less efficiency and high-power consumption is the downside of the oven.

In the proposed system, more efficient microwave oven is formed using the magnetron that has been designed and simulated in CST Studio suite simulator. CST Studio is a solver

module that analyses the motion of particles i.e. electrons in 3-D by using charged particles motion equations and Maxwell's equations.

The number of participations of the electron for the generation of microwaves is achieved by changing the interaction space of the MGT. The length of the anode has been varied and increased toward the cathode side. Due to this electric field is increased in between the interaction space. This electric field gives an adverse effect on the motion of the electron.

The size of the permanent magnet is changed to limit the adverse effect of the electric field. Enhancement in the magnetic field helps in synchronization of the electrons with the RF wave.

The input supply to the magnetron will depend upon the high voltage circuit of the oven. The transformer is used to step up the voltage and the capacitor is charged using this voltage in one half cycle. The other half cycle sums up the output voltage of transformer and charged capacitor and act as input to the MGT. Utilization of this voltage to the MGT was unable to give the required output.

The modified transformer with a capacitor is used to supply the MGT and hence achieved the required output i.e. MW. Also, this modified transformer and capacitor helps to achieve the balancing or impedance matching between the high voltage circuit and MGT so that the losses in between the electrical circuit reduces. The more MW moves to the cavity of the oven and absorbed by the food and hence increase the efficiency of the MWO.

**CONCLUSIONS AND FUTURE WORK**

---

**7.1 Conclusion**

In the presented work, efficiency enhancement of microwave oven has been analysed. It is well known from the literature that the interaction of particles with the wave can be increased by intensifying the field and reducing the interaction gap. Simulation of CW vane type magnetron has been done under CST studio environment. The particles distribution in the interaction space for the proposed and old magnetron has been analysed. It is observed that the distribution of electron in the proposed magnetron are more concentrated and have less kinetic energy as compared to other. Further, five electron spokes confirm the  $\pi$  mode oscillation in the magnetron.

The modelling and simulation of high voltage circuit has been implemented in the MATLAB Simulink environment. The modification in components of high voltage circuit has been analysed for the proper matching of impedance with the magnetron. Simulated values of anode current and voltage are verified experimentally and it is found that there is 0-5% deviation in the simulated values as compared to experimental values.

Further, efficiency of microwave oven has been calculated by a test procedure mention in IEC 60705 standard. Based on the optimised magnetron with impedance matched circuit, it is observed that the efficiency of the microwave oven is increased by 4.5% and reach to 57.9% with respect to the running case.

**7.2 Future Work**

1. Different shape of magnetron with selection of material can be used to enhance the efficiency of the oven.
2. Different shape of cathode such as sharp edge can be simulate or used in order to enhance the emission of the electron from cathode and increase the local electric field.
3. More optimize design of cavity for better impedance matching with magnetron and hence more absorption of waves by load.
4. Feasibility for replacing the HVT circuit by Inverter circuit to reduce the losses.

## LIST OF PUBLICATIONS

---

1. A. Singhal, P. Nijhawan, A. Sinha, K. Rai, "Approach for Efficiency Enhancement of Microwave Oven," *International Journal of Advanced Trends in Computer Science and Engineering (IJATCSE)*, vol. 8, no. 2, pp. 265-270, 2019.

## REFERENCES

---

- [1] M. Gaba, and N. Dhingra, "Microwave chemistry: general features and applications," *Indian Journal of Pharmaceutical Education and Research*, vol. 45, no. 2, pp. 175-183, 2011.
- [2] D. Agrawal, "Latest global developments in microwave materials processing," *Materials Research Innovations*, vol. 14, no. 1, pp. 3-8, 2010.
- [3] D. R. McConnell, "Energy consumption: A comparison between the microwave oven and the conventional electric range," *Journal of Microwave Power*, vol. 9, no. 4, pp. 341-347, 1974.
- [4] Energy Star, "Benefits of Energy Star," *Energy star*, 2019. [Online]. Available: [https://www.energystar.gov/ia/products/downloads/Ovens\\_Product\\_Factsheet\\_Final.pdf](https://www.energystar.gov/ia/products/downloads/Ovens_Product_Factsheet_Final.pdf). [Accessed 07-Mar-2019].
- [5] Ministry of Power, "Bureau of Energy Efficiency," *Government of India, Ministry of Power, New Delhi*, 2019. [Online]. Available: <http://www.beestarlabel.com/>. [Accessed 10 March-2019].
- [6] Ministry of Power, "National Energy Efficiency Strategy Plan," *Government of India, Ministry of Power, New Delhi*, 2019 [Online]. Available: <http://pib.nic.in/PressReleaseIframePage.aspx?PRID=1568321>. [Accessed 28-Apr-2019].
- [7] C. J. Budd and A. D. C. Hill, "A comparison of models and methods for simulating the microwave heating of moist foodstuffs," *International Journal of Heat and Mass Transfer*, vol. 54, no. 4, pp. 807-817, 2011.
- [8] M. E. C. Oliveira and A. S. Franca, "Microwave heating of foodstuffs," *Journal of Food engineering*, vol. 53, no. 4, pp. 347-359, 2002.
- [9] J. M. Osepchuk, "The history of the microwave oven: a critical review," *IEEE MTT-S International Microwave Symposium Digest*, Boston, MA, USA, 7 Jun 2009, pp. 1397-1400.
- [10] J. M. Osepchuk, "A history of microwave heating applications," *IEEE Transactions on Microwave theory and Techniques*, vol. 32, no. 9, pp. 1200-1224, 1984.
- [11] D. Calmettes, J. Cousin and C. Huron, "High-voltage transformer for a microwave oven power supply," *U.S. Patent 5,660,756*, issued August 26, 1997.
- [12] P. Redhead, "The Invention of the Cavity Magnetron and its Introduction into Canada and the USA," *Physics in Canada*, vol. 57, no. 6, pp. 321, 2001.

- [13] G. Churyumov, V. Gerasimov, T. Frolova, A. Gritsunov, and A. Ekezi, "The advanced designs of magnetrons with improvement output characteristics," *IEEE International Vacuum Electronics Conference (IVEC)*, Kharkiv National University of Radio Electronics, Ukraine, 19 Apr. 2016, pp. 1-2.
- [14] I. Araz, A. Dursun, E. Demirci, E. Korkmaz, and K. Yegin, "Simulation of an 18-Vane Magnetron in CST-PIC," *IEEE XXXth URSI General Assembly and Scientific Symposium*, Istanbul, Turkey, 13 Aug 2011, pp. 1-4.
- [15] A. W. Hull, "The Effect of a Uniform Magnetic Field on the Motion of Electrons Between Coaxial Cylinders," *Physical Review*, vol. 18, no. 1, pp. 31, 1921.
- [16] H.A. Boot, and J. T. Randall, "Historical notes on the cavity magnetron," *IEEE Transactions on electron devices*, vol. 23, no. 7, pp. 724-729, 1976.
- [17] A. D. Andreev, and J. K. Hendricks, "First multi-cavity magnetrons were built in NII-9, Leningrad, during the spring of 1937 PIC simulations of the first 4-cavity S-band CW magnetron," *IEEE International Conference on the Origins and Evolution of the Cavity Magnetron*, Bournemouth, UK, 19 Apr. 2010, pp. 71-75.
- [18] E. C. Megaw, "The high-power pulsed magnetron: a review of early developments," *Journal of the Institution of Electrical Engineers-Part IIIA: Radiolocation*, vol. 93, no. 5, pp. 977-984, 1946.
- [19] M. Leconte, "A statistical study of magnetron patents in the early years of electronics between 1920 and 1945; heuristic focusing around the discovery of the cavity magnetron," *IEEE International Conference on the Origins and Evolution of the Cavity Magnetron*, Bournemouth, UK, 19 Apr. 2010, pp. 11-16.
- [20] R. Chandra, S. Ghodke, A. Sharma, A. Patel, and S. Singh, "Design of Relativistic Magnetron for High Power Microwave Generation," *TUPP006*, 2014.
- [21] E. C. Okress, "Magnetron," *U.S. Patent 2,429,291*, 1947.
- [22] A. D. Andreev and J. K. Hendricks, "ICEPIC simulation of a strapped nonrelativistic high-power CW UHF magnetron with a solid cathode operating in the space-charge limited regime," *IEEE Transactions on plasma science*, vol. 40, no. 6, pp. 1551-1562, 2012.
- [23] K. W. Dudley, and G. H. Macmaster, "Raytheon Co: Crossed field microwave device," *U.S. Patent 3,646,388*, 1972.
- [24] T. P. Fleming, M. R. Lambrecht, P. J. Mardahl and J. D. Keisling, "A high-efficiency megawatt-class nonrelativistic magnetron," *IEEE transactions on plasma science*, vol. 40, no. 9, pp. 2112-2118, 2012.

- [25] H. S. Uhm, H. S. Kim, and G. S. Park. "Dispersion relation of the electromagnetic waves propagating through a helix inserted into a magnetron-type conducting cylinder," *IEEE Transactions on plasma science*, vol. 30, no. 3, pp. 1076-1081, 2002.
- [26] E. Melgoza, J. L. Guardado, and V. Venegas. "A method for coupling electromagnetic transients programs with finite element magnetic field solvers," *International Conference on Power System Transients*, Montreal, Mich. Mexico, 19 Jun. 2005, pp. 19-23.
- [27] M. O. Ahmedou, M. Ferfra, N. E. Ghazal, M. Chraygane and M. Maafoufi, "Implementation and Optimization Under Matlab Code of a HV Power Transformer For Microwave Generators Supplying Tow Magnetrons," *Journal of Theoretical and Applied Information Technology*, vol. 33, no. 2, pp. 30, 2011.
- [28] M. Bassoui, M. Ferfra, M. Chraygane, M. Ould Ahmedou, N. Elghazal and B. Bahani, "Modeling of new high voltage power supply with three phase character for microwaves generators with one magnetron by phase under Matlab Simulink code," *ARPJ-Journal of Engineering And Applied Sciences*, vol. 9, no. 12, 2014.
- [29] M. O. Ahmedou, M. Ferfra, R. Nouri and M. Chraygane, "Improved  $\pi$  model of the leakage flux transformer used for magnetrons," *IEEE International Conference on Multimedia Computing and Systems*, Ouarzazate Morocco, 7 Apr. 2011, pp. 1-6.
- [30] G. Liu, and X. B. Xu, "Improved modeling of the nonlinear BH curve and its application in power cable analysis," *IEEE Transactions on magnetics*, vol. 38, no. 4, pp. 1759-1763, 2002.
- [31] M. O. Ahmedou, M. Ferfra, M. Chraygane, and M. Maaroufi, "A New Modeling of the Non-Linear Inductances in MATLAB," *Intech Open in MATLAB-A Fundamental Tool for Scientific Computing and Engineering Applications*, vol. 1, 2012.
- [32] M. Bassoui, M. Ferfra, M. Chraygane, M. O. Ahmedou, N. Elghazal, and A. Belhaiba, "Optimization of a New Three-Phase High Voltage Power Supply for Industrial Microwaves Generators with N Magnetrons by Phase (Treated Case N= 1)," *International Journal of Electrical, Computer, Energetic, Electronic and Communication Engineering*, vol. 7, no. 11, 2013.
- [33] A. Belhaiba, A. Bouzit, N. Elghaza, M. Ferfra, M. Bousseta, M. Chraygane, and B. Bahani, "Comparative studies of electrical functioning of magnetron power supply for one magnetron," *Journal of Engineering Science and Technology Review*, vol. 6, no. 3, pp. 229-238, 2013.

- [34] Y. Zhang, Y. Chen, and B. Zhang, "Modeling and analysis of the stable power supply based on the magnetic flux leakage transformer," *IEEE International Power Electronics and Application Conference and Exposition*, Shanghai, China, 5 Nov. 2014, pp. 614-618.
- [35] J. H. Chan, A. Vladimirescu, X. C. Gao, P. Liebmann, and J. Valainis, "Nonlinear transformer model for circuit simulation," *IEEE Transactions on Computer-Aided Design of Integrated Circuits and Systems*, vol. 10, no. 4, pp. 476-482, 1991.
- [36] B. Bahani, A. Bouzit, M. Chraygane, M. Ferfra, N. E. Ghazal, and A. Belhaiba, "Modeling of a New High Voltage Power Supply for Microwave Generators with Three Magnetrons," *International Journal of Electrical and Computer Engineering (IJECE)*, vol. 3, no. 2, pp. 164-170, 2013.
- [37] N. E. I. Ghazal, A. Belhaiba, M. Ferfra, M. Chraygane, and B. Bahani, "New simulation method of new hv power supply for industrial microwave generators with n= 2 magnetrons," *International Journal of Advanced Computer Science And Applications*, vol. 4, no. 12, 2013.
- [38] IEC International Electrotechnical Commission, "Household Microwave Ovens- Methods for Measuring Performance," *Geneva: International Electrotechnical Commission*, 1999.
- [39] A. Bouzit, M. Chraygane, N. Elghazal, M. Fadel, M. Ferfra and M. Bassoui, "Modeling of New Single-Phase High Voltage Power Supply for Industrial Microwave Generators for N= 2 Magnetrons," *International Journal of Electrical & Computer Engineering (2088-8708)*, vol. 4, no. 2, 2014.
- [40] M. Vakilian and R. C. Degeneff, "A method for modeling nonlinear core characteristics of transformers during transients," *IEEE transactions on power delivery*, vol. 9, no. 4, pp. 1916-1925, 1994.
- [41] Engineering and Technology History, "Microwave Oven," *Engineering and Technology History*, 2019. [Online]. Available: [https://ethw.org/Microwave\\_Ovens](https://ethw.org/Microwave_Ovens). [Accessed 24-Apr-2019].
- [42] Toshiba Hokuto Electronics Corporation, "Magnetron for Microwave Oven," *Toshiba Hokuto Electronics Corporation*, 2019. [Online]. Available: <http://www.hokuto.co.jp/eng/products/magnetron/index.htm>. [Accessed 01-May-2019].
- [43] M. I. Skolnik, "Introduction to Radar Systems" Mc Graw- Hill, Seventh edition, 2001.

- [44] J. Benford, J. A. Swegle, E. Schamiloglu, "High power microwaves" CRC press, Second edition, 2015.
- [45] G. B. Collins, "Microwave magnetrons" McGraw-Hill, 1948.
- [46] Wol C. Magnetron, "Basic of Radar," *Wol C. Magnetron*, 2019. [Online]. Available: <http://www.radartutorial.eu/08.transmitters/Magnetron.en.html>. [Accessed 19- Feb- 2019].
- [47] V. Bagad, "Microwave Engineering – I" Technical Publications Pune, First edition, 2009.
- [48] S. Y. Liao, "Microwave Electron-Tube Devices" Prentice-Hall, 1988.
- [49] Y. G. Ding, Z. C. Zhang, "Travelling Wave Tubes Magnetrons Cross-Field Amplifiers," *In Gyrotrons National Defense Industry Press*, 2012.
- [50] S. E. Tsimring, "Electron beams and microwave vacuum electronics" Wiley-Inter science, 2007.
- [51] Jr. Gilmour, S. Alexander "Microwave tubes," *Dedham, MA, Artech House*, pp.502, 1986.
- [52] L. Ma, "3D computer modeling of magnetrons," *Department of Electronic Engineering Queen Mary, University of London United Kingdom December*, 2004.
- [53] R. Miller, "An introduction to the physics of intense charged particle beams" Springer Science & Business Media, 2012.

7%

SIMILARITY INDEX

3%

INTERNET SOURCES

3%

PUBLICATIONS

3%

STUDENT PAPERS

PRIMARY SOURCES

- 1** Submitted to University of Adelaide  
Student Paper <1%
- 2** Mohammed A H Ali, Chang Yong En. "Control of wheeled mobile robot in restricted environment", IOP Conference Series: Materials Science and Engineering, 2018  
Publication <1%
- 3** internationalscienceindex.org  
Internet Source <1%
- 4** Andrey D. Grigoriev, Vyacheslav A. Ivanov, Sergey I. Molokovsky. "Microwave Electronics", Springer Nature, 2018  
Publication <1%
- 5** Andreev, Andrey D., and Kyle J. Hendricks. "ICEPIC Simulation of a Strapped Nonrelativistic High-Power CW UHF Magnetron With a Solid Cathode Operating in the Space-Charge Limited Regime", IEEE Transactions on Plasma Science, 2012.  
Publication <1%