

Microstrip Antenna Optimization using Artificial Neural Network

*Dissertation submitted in the partial fulfillment
of requirements for the award of degree of*

**Master of Engineering
in
Wireless Communications**

Submitted by
Yogesh Maharishi
Roll No. 801363030

Under guidance of
Ms. Amanpreet Kaur
Assistant Professor



Electronics and Communication Engineering Department

THAPAR UNIVERSITY

(Established under the section 3 of UGC Act, 1956)

PATIALA-147004 (PUNJAB)

July, 2015

Certificate & Declaration

I, hereby declare that the work, which is being presented in the dissertation, entitled “**Microstrip Antenna Optimisation using Artificial Neural Network**” in partial fulfillment of the requirements for the award of degree of Master of Engineering in Wireless Communications submitted at Electronics and Communication Engineering Department of Thapar University, Patiala, is an authentic record of my own work carried out under the guidance of **Ms. Amanpreet Kaur (Assistant Professor)**, Electronics and Communication Department and refers other research’s work which are duly listed in reference section. The matter presented in this dissertation has not been submitted in any other University/Institute for the award of degree.

Date: 14.07.2015

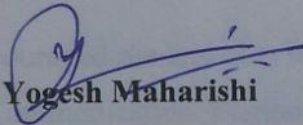

Yogesh Maharishi
Roll No. 801361030

It is certified that the above statement made by the student is correct to the best of my knowledge and belief.

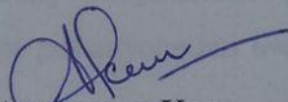
Date: 14/7/15

Ms. Amanpreet Kaur
Assistant Professor
ECED, Thapar University

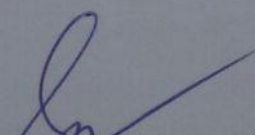
Countersigned by

Dr. Sanjay Sharma
Professor and Head (ECED)
Thapar University, Patiala

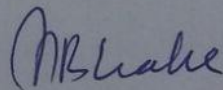
Dr. S. S. Bhatia
Dean, Academic Affairs
Thapar University, Patiala

Acknowledgement

I would like to express my gratitude to my guide **Ms. Amanpreet Kaur (Assistant Professor)**, Electronics and Communication Engineering Department, Thapar University, Patiala, for their advice, kind assistance, and invaluable guidance. It has been a great honour to work under them.

I am also thankful to **Dr. Sanjay Sharma**, Head, Department of Electronics and Communication, Thapar University, Patiala, for providing the opportunity to carry out the present work.

I am also very thankful to **Dr. Amit Kumar Kohli, P.G. Coordinator**, Electronics and communication Engineering Department, for the motivation and inspiration that triggered me for this work.

I am greatly indebted to all of my friends who constantly encouraged me and also would like to thank all the faculty members of Electronics and Communication Engineering Department for the full support of my work. I am also thankful to the authors whose work have been consulted and quoted in this work.

Finally, I would like to thank my parents for allowing me to realize my own potential. All the support they have provided me over the years was the greatest gift anyone has ever given me.

Yogesh Maharishi
Roll no. 801363030

Abstract

In the modern era of wireless communication there is a need for an antenna with reduced size, higher bandwidth (to support high data rate), fewer losses and ability to operate at high frequency. The microstrip antenna is one of the most favorable candidates in this context and is compatible with today's wireless scenario because of their smaller size, ability to operating at high frequency, and ease of installation. The microstrip antenna is used in mobiles, satellite communication devices, radars etc. Because of the versatility of the microstrip patch, a lot of research work have been done and is going on today.

The tool(software) used for designing these antennas in today's scenario is the EM simulation software. Although it is precise, it is very time consuming and complex example of which are CST(computer simulation technique), IE3D etc. The primary objective of the thesis is to use a neural network as a tool to reduce the consumed time and computational complexity in designing of an antenna. The Neural network has favorable properties in this context including the ability to highly non linear input output relationships, the property of generalization and less time consuming. It is turning out to be a very efficient tool in Antenna optimization.

There are different kinds of neural techniques that can be used based on the application. The most commonly used neural techniques are feedforward with back propagation algorithm, which operates on the gradient descent method, and the RBF (radial basis function) NN, which work based on the principle of distance between the input and the weight vector. These two techniques are widely used and accepted in the application of the neural network in the field of antenna. The thesis has two main objectives. The first one is to optimize the microstrip patch dimension using the neural network and, the second one is to predict the directivity of a planar array by using neural network.

The size of the antenna plays a central part in today's wireless scenario because of less space availability and the portability issue. The work is present here to optimize the dimension of microstrip patch using RBF neural network. Further, in order to make use of neural network more versatile the neural network is applied to a microstrip planar array for the purpose of directivity estimation. Since directivity plays a key role to steer a beam in a particular

direction, so to enhance directivity a microstrip planar array is designed, then to estimate the EM simulated directivity the Feed forward and RBF neural network is utilized.

It is found that RBF neural network produces favorable results but the Feed forward network with back propagation algorithm produces more accurate and precise optimization.

TABLE OF CONTENTS

Certificate & Declaration	i
Acknowledgement	ii
Abstract.....	iii
Table of Contents	v
List of Abbreviations & Symbols.....	viii
List of Figures.....	x
List of Table.....	xii
Chapter 1 Introduction	1
1.1 Antenna	1
1.1.1 Radiation from antenna.....	2
1.1.2 Historical developments in antenna	2
1.1.3 Different types of antenna	3
1.2 Microwave antenna	4
1.2.1 Microstrip antenna	5
1.2.2 Structure of microstrip antenna.....	6
1.3 Antenna array configuration	7
1.3.1 Two element array	7
1.3.2 Linear array.....	9
1.4 Directivity	10
1.5 Neural network	12
1.6 Motivation for work.....	13
1.7 Summary of objectives	14
1.8 Organization of work	15
1.9 Summary.....	16
Chapter 2 Literature Survey.....	17

Chapter 3	Antenna Designing and Simulation.....	26
3.1	Basic for designing a conventional patch antenna	26
3.1.1	Design of square patch.....	27
3.1.2	Reflection coefficient analysis	28
3.1.3	Design specifications	28
3.1.4	Variation of parameters and data collection	29
3.2	Basics for planar array.....	30
3.2.1	Designing of array.....	32
3.2.2	Specification of designed array.....	32
3.3	Summary.....	33
Chapter 4	Neural Network.....	34
4.1	ANN Model	34
4.1.1	Some transfer functions “f”	36
4.1.2	Advantages of ANN.....	38
4.1.3	Limitations of ANN	38
4.2	Feed Forward BP net.....	38
4.2.1	Back propagation training.....	39
4.2.2	BP Simulation.....	41
4.3	Radial Basis Function Networks.....	41
4.3.1	RBF Training.....	42
4.3.2	RBF Simulation.....	43
4.3.3	Summary.....	43
Chapter 5	Results and Discussions.....	45
5.1	Optimization of Patch parameters using RBF ANN.....	45
5.2	Neural application on planar array.....	50
5.2.1	Feedforward NN with BP algorithm.....	59

5.2.2 Estimation using RBF NN.....	62
5.3 Summary.....	68
Chapter 6 Conclusion and Future scope.....	69
6.1 Conclusion.....	69
6.2 Future Scope.....	70
Reference.....	72
List of Publications.....	76

List of Abbreviations & Symbols

ANN	Artificial Neural Network
BP	Back Propagation
RBF	Radial Basis Function
CST	Computer Simulation Technique
MLP	Multi layer perceptron
MSE	Mean square error
RF	Radio frequency
LM	Levenberg-Marquardt
EM	Electro magnetics
af	Array factor
af_n	Normalized array factor
ISM	Industrial Scientific and Medical
FTDT	Finite difference time domain
FIR	Finite Impulse Response
BFO	Bacteria foraging optimization
PSO	Particle swarm algorithm
GA	Genetic algorithm
SLL	Side lobe level
GRNN	Generalized regression neural network
SVM	Support vector machine
WLL	Wireless local loop
GSM	Global service for mobile

ADS	Advance design system
DF	Direction finding
MOM	Methods of moments
RMS	Root mean square
RPROP	Resilient backpropagation
VSWR	Voltage standing wave ratio
PIFA	Planar inverted fractal antenna

Symbols

ξ_r	Dielectric Constant
$\xi_{reff.}$	Effective dielectric constant
df	Display frequency
β	Phase Shift
R	Total number of inputs to neural network
N	Total number of antenna element
k_0	Wave number

List of Figures

Figure1.1	Basic Structure of Microstrip antenna	6
Figure1.2	A 2 element linear array	8
Figure1.3	N-element linear array	10
Figure1.4	A biological neuron	13
Figure3.1	S11(dB) versus frequency for with and without inset feed	28
Figure3.2	Proposed design for square patch	29
Figure3.3	Basic structure for planar array	30
Figure3.4	Proposed design for planar array	32
Figure4.1	ANN Structure	35
Figure4.2	Different Transfer(Activation functions)	36
Figure4.3	MLP Feedforward Architecture with Back propagation	39
Figure4.4	RBF ANN Structure	42
Figure5.1	RBF performance plot for 2 hidden layer neurons	46
Figure5.2	RBF performance plot for 5 hidden layer neurons	47
Figure5.3	RBF performance plot for 8 hidden layer neurons	47
Figure5.4	MSE with respect to different number of neurons in hidden layer	48
Figure5.5	RBF output with respect to different neurons in hidden layer	50
Figure5.6	ANN Model	59
Figure5.7	Average MSE with respect to number of neurons in hidden layer	61
Figure5.8	Feedforward performance plot with 15 neurons in hidden layer	62
Figure5.9	RBF MSE plot for different number of neurons in the hidden layer	63
Figure5.10	RBF NN performance	64

Figure5.11 Estimated Directivity versus inter element distance by different neural techniques 65

Figure5.12 Estimated SLL versus inter element distance by different neural techniques 66

LIST OF TABLES

Table3.1	Resonant frequency at various length of patch	29
Table3.2	Parameter specification for planar array	32
Table5.1	Test data set for RBF NN	45
Table5.2	RBF specifications	46
Table5.3	MSE with respect to different number of neurons in RBF hidden layer	48
Table5.4	Neural estimated frequencies	49
Table5.5	CST simulated Directivity and SLL with respect to distance	51
Table5.6	Average MSE with respect to different hidden layer neurons	60
Table5.7	MSE with respect to different number of hidden layer neurons for RBF NN	63
Table5.8	Estimated results with Feedforward and RBF NN	66

Chapter 1

Introduction

In the innovation era of wireless communication antenna systems plays a key role since its inception. They are used to produce radiation from transmitter to receiver through wireless channel. The components of antenna are designed to satisfy the demand of user. In today's scenario the emphasis is given on miniaturization of the components. An increase in the operating frequency results in size reduction. The technology is changing day by day such that device introduced today is getting outdated next day. There is a significant change in technology in the last decade. So researchers have observed considerable measure of alteration in the wireless technology. To achieve objective of the optimum size of devices with higher data rate, there is a shift in operating frequency from radio frequency to microwave frequency. So while designing antenna this fact should be taken into account in order to meet user's requirements. The conventional EM simulation tools based on different algorithms have their own pros and cons. In designing any antenna these techniques encounter too much computational complexity and require more time leading to an inefficient approach. Here comes the need of an efficient tool for optimization and synthesization purpose in context of antenna, the ANN is turned to be a favorable candidate for this purpose. How close an ANN is capable of predicting EM simulated results, this fact is known as optimization.

1.1 Antenna

In context of communication antenna is a conductor which converts electrical energy into the electromagnetic energy at the transmitter end and electromagnetic energy to electrical energy at the receiver terminal. According to the theory of radiation given in [2], the radiation of EM wave can only occur if there exist a current carrying conductor having change in the velocity of current, whether it occurs in the form of acceleration and deceleration. It implies that constant current carrying conductor cannot produce radiation. This change in the velocity of current can be brought by introducing bends and discontinuities in the antenna structure. Oscillating current also causes radiation of EM waves. To improve unintended radiation

effect of any conductor acting as an antenna several majors are to be taken like shielding of antenna which leads to dampening the radiation. But if proper design is chosen for antenna the EM radiation can be controlled in order to suit different applications such as focusing the energy in a specific direction, selecting specific frequency etc. The distance upto which any antenna is liable to radiate depends upon the antenna used.

1.1.1 Radiation from Antenna

Radiation in antenna mainly occurs due to changes in current density with respect to its size. A flow of charge is basically known as current. If the charge is flowing in the conductor have a uniform velocity than antenna will not radiate, if there is variation in the speed the wire will tend to radiate in the free space. In wireless communication the energy is to be radiated in the free space. In order to make antenna radiate this uniform current density can be interrupted by introducing abrupt changes, discontinuities, bends etc. There are many other ways to generate time varying current in conductor. In [2] radiation mechanism of antenna is discussed. Two parallel transmission lines produce an electric line of forces from one wire to another if the dimension of conductor is λ . If two transmission lines are placed in parallel, then electric lines of force generated inside cancel each other, if they are flared out from any of one side then it will disturb the electric lines of force. This disturbance at one end loosens up the electric lined at one end and antenna will tend to radiate.

1.1.2 Historical Developments in Antenna

As explained in section 1.1, Existence of EM waves proved by the Hertz experiment in 1888. A $\lambda/2$ dipole was used in the experimentation. Later the Horn antenna is used by the scientist J.C. Bose in 1897. In 1901, G. Marconi used 50 vertical wires in the form of a fan at transmitter side and a 200m wire supported by flying kite to sent signal transatlantic from England to Newfoundland. Earlier the antenna technology was limited to wire antennas. Invention of microwave component in world war – II, took technology beyond wire antennas. In this era mainly aperture antenna was introduced. Waveguide horn, slot, reflector, open ended waveguide and lens antenna are the various types of antenna introduced during world war- II [2]. The antenna introduction enabled wireless communication in applications like radar and remote sensing in era of world war – II.

1.1.3 Different types of antenna

Depending on the characteristics parameters viz. shape, material used and radiating structure antenna are classified into different categories. On the basis of directive property, an antenna can be classified into directive or isotropic antenna. Wire antenna, planar antenna, fractal antenna, horn antenna, reflector and dielectric lenses are some classification according to the shape. The dielectric antenna and metallic radiating antenna are classified on the basis of material used. The radiating structure may work on the principle of resonance or it may be a leaky wave antenna.

Isotropic and directive antennas

Isotropic antenna is the hypothetical antenna which is considered as ideal antenna. It is a lossless antenna, which radiates equally in all directions. On the other side directional antennas radiate energy less or more in a particular direction.

Wire Antennas

Wire antenna composed of metallic wires with finite length having the capability to radiate EM waves at specific frequency. Short dipoles, half wave dipoles, folded dipole, monopole and loop antenna are some example of wire antennas. The simplest type of antenna is the short dipole also termed as hertz dipole. The short dipole has length quite smaller than the wavelength of the wave. The current distribution of this type of antenna is triangular distributed. This antenna is classified under category of narrowband antenna. Antenna having length $\lambda/2$ is termed as half wave dipole. They are more directional characteristics as compared to short dipole. The half wave dipole has omni-directional characteristics. Half length of $\lambda/2$ antenna is known as monopole antenna. The placement of antenna is done vertically above the large ground plane. One end of feed is connected to radiator and other is connected to ground of a monopole antenna.

Planar Antennas

They belong to one of the recent trend in antenna designing. The conductor when stuck to planar surface is called planar antennas. Microstrip antennas are the most popular antenna structure. Substrate, patch and ground are the components of the microstrip patch. They can be of various shapes like rectangular, triangular and circular etc. based on their desired specifications. The patch antennas also support fractal shapes, which can be utilized for multiband and broadband performance. Low profile and ease of integration with feed network are the key advantage that makes them popular in this era.

Horn Antenna

Flared out waveguide structure with flaring in different axis is known as Horn Antenna. They can further be classified as E-plane horn, H-plane horn and pyramidal horn. Horn antennas are popular in high directive gain category of antennas. They are most commonly applied in measurement of gain of any test antenna.

Reflectors and dielectric lenses

Reflectors are further classified according to their geometrical configuration. Plane, corner and parabolic (Curved) Reflectors are some popular configuration of reflectors. They consist of large size and utilized to increase the gain of antenna. Lens antennas are used to collimate diversified waves. They are used to prevent the spread of the wave in undesired directions. Dielectric lenses are most commonly used in modern day applications.

Modern day antennas

The primary example of modern day antennas are Planar inverted F antenna (PIFA) which is used for mobile applications. The other examples are near field communication antennas and Dielectric resonators.

1.2 Microwave antenna

The microwave communication is the higher range of frequency which consist of band of 1GHz to 30 GHz. Microwave communication offers shift to higher frequencies leading to encourage the next generation technologies. The advantages can be enumerated as follows

- More bandwidth availability enables communication system to carry large amount of information. Thus the speed of data transfer can be increased using microwave communication.
- Can be attributed as communication with high penetration power.
- Size reduction of the component size at these frequencies, as size is directly proportional to the wavelength. The wavelength of microwave is quite less, so the size of the antenna is quite less.
- Line of sight communication is possible over large distances. The satellite communication is one of the applications at microwave frequency.

A smaller wavelength is the key advantage that a microwave communication system has inherited in it. $\lambda/2$ is the size of a half wave dipole, which results in antenna size of millimeters. Microwave antenna is very significant component in microwave communication. Longer wavelength communication is affected by the object of comparative size, at microwave frequencies wavelength is too short which results in much less interference from the object. The commonly used antenna at microwave frequency is microstrip antenna which is explained as under

1.2.1 Microstrip Antenna

The microstrip antenna was evolved in the early 1950s, they got popular in the 1970s. They are likewise known as patch antennas and planar antennas. It is composed of substrate, patch and ground plane. Substrate is made of dielectric material while the patch and ground plane are conductor. Microstrip antenna was evolved in the early 1950s as planar antenna. Microstrip patch is considered as a narrowband antenna in their basic form, they enjoy the advantages of low profile, ease of integration, planar and conformal to the base, low cost manufacturing etc. Microstrip antennas are utilized in diverse areas such as biomedical application, radio communication and other government & commercial application, such as mobile radio and wireless communication having similar specification to meet some of its requirements [1]. Microstrip antennas are utilized in high frequency operations, mostly for the microwave communication bands. The limitations are low bandwidth and low power handling capacity, which can be overcome by proper selection of substrate thickness and dielectric constant as well as proper means of feeding [3]. One of the common problems

related to this antenna is the surface wave excitation. Microstrip antennas are very significant device for the next generation wireless systems. They can be of different shapes and sizes like rectangular, square, circular, elliptical etc. These antennas have some limitations such as low radiating efficiency, poor polarization purity and scan performance, narrow frequency bandwidth, must be operated at low power levels, and produce spurious feed radiation, among others. Many limitations can be mitigated by considering the careful design. Research on microstrip patch is aimed for its size reduction, high gain, wide bandwidth [4]. The major design task is to optimize the dimensions of the rectangular microstrip patch antenna. An increase in the height of substrate leads to increase in efficiency of the antenna, by placing antenna elements in array formation the scanning and directivity properties of antenna system can be improved. Although caution must need to be taken while designing because there is a tradeoff between various factors, so improvement in one parameter can lead to decline the performance of another one. Thus, compromises and tradeoffs are always essential during the design process, regardless of the antenna type. Square patch is the special case of rectangular patch. The most commonly used structures are chosen because of ease of analysis in the form of radiation characteristics described in the mathematical form. If the complexity of taken design increases than the there will be difficulty in modeling the radiation characteristics. Microstrip antennas provide choice in selecting several performance characteristics, such as operating frequency, radiation pattern, polarization, and element impedance by relatively simple modifications in the structure. Modification and changes are shown in next section in the context of square patch more specifically.

1.2.2 Structure of microstrip antenna

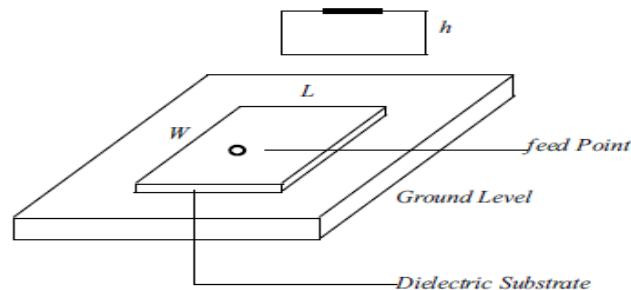

Figure 1.1 Basic structure of microstrip patch [2]

Equations for numerical analysis of patch antenna are shown below.

$$L_{eff} = c / (2f_r \sqrt{\xi_{eff}}) \quad (1.1)$$

$$w = c / 2f_r \sqrt{\left[\frac{(\xi_r + 1)}{2} \right]} \quad (1.2)$$

$$\xi_{eff} = (\xi_r + 1) / 2 + (\xi_r - 1) / 2 [1 + 12h / w]^{-5} \quad (1.3)$$

Equations for Patch Antenna [2]

Where L_{eff} the effective length of patch, w is is is the width and ξ_{eff} is the effective value of dielectric constant.

1.3 Antenna Array Configurations

In the above section theory about single antenna element was discussed. The performance of a single antenna can be improved by placing multiple antennas with suitable adjustment in some parameters. In this section basic theory behind the antenna array is discussed, term array factor will be introduced and typical array formation like linear, planar will be discussed. Most of theory and mathematical equation part is taken from [2] and [5].

1.3.1 Two-Element Array

In figure 1.2 a two element array is shown under the far field condition. Both the element are place along the z -axis and have equal distance from the origin ($d/2$). Neglecting all the losses, the field radiated by each element can be described as:

$$\vec{E}_1 \approx E_0 \left(\frac{e^{-j \left[kr_1 - \frac{\beta}{2} \right]}}{r_1} \cos \theta_1 \right) \theta \quad (1.4)$$

$$\vec{E}_2 \approx E_0 \left(\frac{e^{-j \left[kr_2 - \frac{\beta}{2} \right]}}{r_2} \cos \theta_2 \right) \theta \quad (1.5)$$

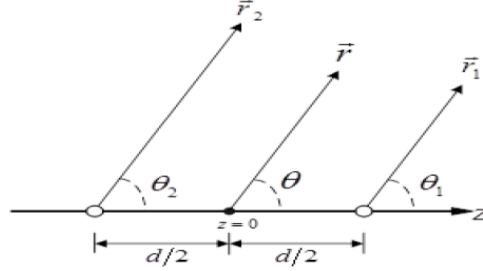

Figure 1.2 A 2-element linear array

Where β is the phase difference. Both elements are excited with equal magnitude. For the far field analyses following assumptions are taken into account

$$\theta \approx \theta_1 \approx \theta_2 \quad (1.6)$$

$$r \approx r_1 \approx r_2 \quad (1.7)$$

$$r_1 \approx r - \frac{d}{2} \cos \theta \quad (1.8)$$

$$r_2 \approx r + \frac{d}{2} \cos \theta \quad (1.9)$$

Applying these assumptions on the above equations

$$\vec{E}_1 = \frac{E_0 e^{-jkr}}{4\pi r} \cos \theta \left[e^{j(kd \cos \theta + \beta)/2} \right] \theta \quad (1.10)$$

$$\vec{E}_2 = \frac{E_0 e^{-jkr}}{4\pi r} \cos \theta \left[e^{-j(kd \cos \theta + \beta)/2} \right] \theta \quad (1.11)$$

The total radiated field can be given as

$$\vec{E}_T = \vec{E}_1 + \vec{E}_2 \approx \frac{E_0 e^{-jkr}}{4\pi r} \cos \theta \left[e^{-j(kd \cos \theta + \beta)/2} \right] \theta \quad (1.12)$$

$$\vec{E}_T \approx \frac{E_0 e^{-jkr}}{4\pi r} \cos \theta 2 \cos \left[\frac{1}{2} (kd \cos \theta + \beta) \right] \theta \quad (1.13)$$

By examining equation 1.13 it is observed that the total radiated field by the antenna array can be expressed as field radiated by the single element placed at the origin multiplied by what is known as array factor.

$$af = 2 \cos \left[\frac{1}{2} (kd \cos \theta + \beta) \right] \quad (1.14)$$

$$af_n = \cos \left[\frac{1}{2} (kd \cos \theta + \beta) \right] \quad (1.15)$$

Where af_n is the normalized form of the array factor.

1.3.2 Linear Array

In order to improve the performance of the array number of elements can be increased to N along the same axis and array factor expression can also be extended to N number of elements. Thus formed array is termed as N -element linear array. Linear array with N -elements placed along z -axis is shown in fig. 1.3. The theory for a two-element array factor can also be expanded to include N number of elements along the same axis. Elements in the array are identical and have phase difference of β from the nearest element; this array may also be termed as nearest element. The array factor for the N element linear array can be expressed as:

$$af = 1 + e^{j(kd \cos \theta + \beta)} + e^{j2(kd \cos \theta + \beta)} + e^{j3(kd \cos \theta + \beta)} + \dots + e^{j(n-1)(kd \cos \theta + \beta)} \quad (1.16)$$

$$af = \sum_n^{N-1} e^{j(n-1)(kd \cos \theta + \beta)} \quad (1.17)$$

Using trigonometric properties eq. 1.17 can be written as

$$af = e^{j[(N-1)/2](kd \cos \theta + \beta)} \left[\frac{\sin \left(\frac{N}{2} (kd \cos \theta + \beta) \right)}{\sin \left(\frac{1}{2} (kd \cos \theta + \beta) \right)} \right] \quad (1.18)$$

Normalized array factor can be written as

$$af_n = \frac{1}{N} \left[\frac{\sin\left(\frac{N}{2}(kd \cos \theta + \beta)\right)}{\sin\left(\frac{1}{2}(kd \cos \theta + \beta)\right)} \right] \quad (1.19)$$

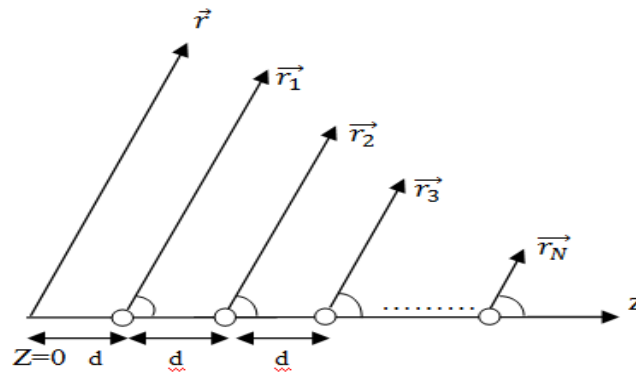

Figure 1.3 N-element linear array

1.4 Directivity

Directivity also known as directive gain is a measure of capability of antenna to focus its radiation intensity in a particular direction with respect to average radiation intensity in all direction. For any antenna directivity D is defined as

$$D = \frac{U}{U_0} \quad (1.20)$$

Where U is the radiation intensity in a particular direction and U_0 is the average radiation intensity in all direction (isotropic radiation). In the case of isotropic radiator U and U_0 are equal, that results in directivity value of 1 in any possible direction. In other terms directivity can also be defined as radiation intensity in a particular direction to radiation intensity of an isotropic antenna. In case direction is not defined, it is assumed that directivity is calculated for the direction of maximum radiation intensity.

$$D = \frac{U_{\max}}{U_0} \quad (1.21)$$

For a microstrip patch, directivity for a single slot can be calculated in terms of its width W , the wavelength in free space λ_0 , and the wave number k_0

$$D_0 = \left(\frac{2\pi W}{\lambda_0} \right)^2 \frac{1}{I_1} \quad (1.22)$$

Where I_1 is defined as

$$I_1 = \int_0^\pi \left[\frac{\sin\left(\frac{k_0 W}{2} \cos \theta\right)}{\cos \theta} \right]^2 \sin^3 \theta d\theta \quad (1.23)$$

The more practical way to find the directivity of microstrip antenna is directivity with two slots, since it has two slots that radiate. The directivity for the two slots (D_2) can be calculated as

$$D_2 = \left(\frac{2\pi W}{\lambda_0} \right)^2 \frac{\pi}{I_2} \quad (1.24)$$

Where I_2 is calculated as:

$$I_2 = \int_0^\pi \int_0^\pi \left[\frac{\sin\left(\frac{k_0 W}{2} \cos \theta\right)}{\cos \theta} \right]^2 \sin^3 \theta \cos^2 \left(\frac{k_0 L_e}{2} \sin \theta \sin \phi \right) d\theta d\phi \quad (1.25)$$

For the dominant mode TM_{010}^z , D_2 can be calculated in terms of D_0 as:

$$D_2 = \frac{2D_0}{1 + G_{12}/G_1} \quad (1.26)$$

Where G_1 and G_{12} can be calculated as

$$G_1 = \frac{1}{120\pi^2} \int_0^\pi \left[\frac{\sin\left(\frac{k_0 W}{2} \cos \theta\right)}{\cos \theta} \right]^2 \sin^3 \theta d\theta \quad (1.27)$$

$$G_{12} = \frac{1}{120\pi^2} \int_0^\pi \left[\frac{\sin\left(\frac{k_0 W}{2} \cos \theta\right)}{\cos \theta} \right]^2 J_0(k_0 L \sin^3 \theta) d\theta \quad (1.28)$$

Where J_0 is the Bessel function of the first kind of zero order.

1.5 Neural network

The previous chapter covers the brief introduction about the antenna. As explained above, there is a massive amount of non linearity between input and output parameter of the antenna. The numerical approach and EM simulation techniques are found to be inefficient to handle this non linearity. Remedy to this problem is an artificial neural network (ANN) represented as a viable candidate. It is composed of massive numbers of highly interconnected processing elements called neurons, working in union to resolve specific problems. ANN is like a normal human which learn by examples. [6] In this chapter the brief introduction about neural network is given, beginning from the earliest stage development to present stage development. Two types of neural networks are considered: The Feed forward with back propagation and the radial basis function (RBF-NN). General architectures,

training algorithms and simulation processes of these networks will be discussed. The theory and figures shown in this chapter are obtained from [7].

The main objective to create ANN is to handle certain task which can be challenging and time consuming from the perspective of computers and software (tools). The human brain works on highly parallel data processing which makes it capable of performing the multitasking and fault tolerance. General diagram of biological neuron is shown in the Figure1.4. Information is exchanged between the neurons in the form of electrical impulses, which are received by dendrites. The connection between neurons is called synapses. Impulses then flow to the cell body, where the information is processed. After processing of impulse signal the neuron may or may not fire impulses response to received impulses. Transmission of any generated impulse from one neuron to another is through the axon

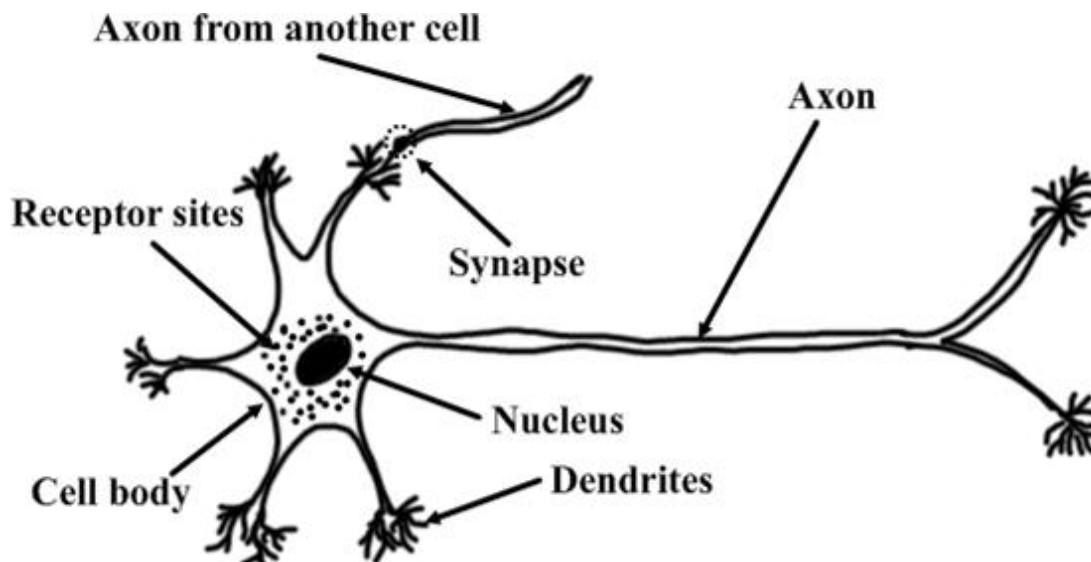

Figure 1.4 A Biological Neuron

1.6 Motivation for work

Because of versatility in design and desirable characteristics the microstrip antennas are used in a variety of application such as military, civilian etc. Although microstrip concept is not new there are many research opportunities. For instance, in [8] work done concentrates on calculation of the radiation pattern of a rectangular microstrip patch having uniform a substrate, in [9] work presents modified rectangular microstrip antennas, using proximity

feeds. The above work was limited to single element only, by increasing the number of elements versatility of design can be enhanced.

A lot of research has been done in the area of neural network application on the antenna designing, optimization and synthesis. Work done in [10], proposes a multilayered feed forward network to predict the gain of a patch. The work is based on the variation of resonant the frequency and the angle of observation on the azimuth plane. In [11] utilizes the multilayered feed forward network to synthesize the radiation pattern of antenna. Work presented in [12] uses MLP NN to estimate resonant frequency of patch antenna based on some design characteristics (length, width, height and relative permittivity are chosen as input parameter). Similar work is shown in [13] with some extended form, it uses three different kind of neural networks (BP, RBF and GRNN) and have three dimensional input and output. Work done in [14] is somewhat similar to that of [9], with the difference that it uses RBF NN in spite of MLP.

1.7 Summary of objectives

Design of Microstrip square patch: At first a microstrip patch is designed using CST simulation software operating on frequency 2.4 GHz(ISM band). The design frequency is considered 2.4 GHz because of many household applications. The comparison of designing of an antenna with and without inset is also done with the help of the reflection coefficient (S_{11}) parameter. The selection of antenna is done on the basis of smaller size, ease of installation and fabrication. Microstrip antennas are the appropriate candidate in this context because they can be used in small size devices such as laptop, mobiles, wireless routers, satellite applications where space plays an important role. Due to low profile they can also be mounted on the moving vehicles. Work done in [14] shows the application of RBF ANN on the rectangular patch and results are analyzed by varying the numbers of neurons in the hidden layer.

Design of Microstrip planar array: A 2*2 microstrip planar array is designed operating on 2.4GHz. The main aim is to predict the directivity and side lobe level for array at different distances and find out best one of them using neural networks. Two types of neural networks are applied to predict results. These networks would be compared and contrasted to each

other in order to find out best of them in terms of network size, accuracy and generalization capabilities.

Simulation using CST software: As we know for a microstrip patch operating frequency varies inversely against the dimensions. So after design samples for different operating frequencies are obtained at different length. These simulations have done using parametric sweep option in CST software. These EM simulations are done in order to get precise readings because modern software packages can provide more insight to the additional factors to be considered without necessarily increasing the analysis complexity for the designer.

In similar way simulation data are obtained for the designed microstrip patch array. Around 240 data samples of directivity and SLL are obtained at different d/λ (normalized distance).

Optimization using neural network: After designing and simulating results from CST simulation software based on FDTD algorithm the different neural networks are trained and tested to get best optimized results. Neural networks are utilized for this purpose because of their versatility. Feed forward net with back propagation algorithm and RBF neural network are utilized in optimization and the results are compared in order to get optimal solution.

1.8 Organization of work:

The next chapter (chapter2) covers the basic of antenna and basic aspects of antenna designing. Emphasis is given on the designing of a square patch antenna.

Chapter 2 is the Literature review which basically deals with analysis of the past work which has been done in this area. This chapter contains the basic of microstrip antenna, different type of performance criteria of antenna. This chapter also covers the requirement of antenna for modern wireless communication. It also presents studies about various neural techniques in optimization and synthesis of antenna.

Chapter3. This chapter is devoted to the study of designing of a square patch antenna and a 2×2 planar array. The analysis has been done using CST EM simulation software based on

FTDT algorithm. The main objective of this chapter is to illustrate the optimum design parameter for a square patch antenna and a planar array.

Chapter4. This chapter deals with the implementation of neural network on the simulated results of designed antenna structures. The different networks are trained with different algorithms. To find out best of them results are compared and optimal network is selected on the basis of performance.

Chapter5. This chapter is devoted to discussions of various results obtained in the presented work. Firstly the results related to estimated resonant frequency of patch using RBF NN are discussed, after that results obtained for Directivity and SLL for a planar array are discussed.

Chapter6. In this chapter the conclusive remarks made about the work done and future possibilities for improvement are discussed.

1.9 Summary

This chapter shows motivation for the thesis. The historical development of wireless communication and historical perspective of antenna designing is given in this chapter. Types of various antennas are also described and antenna array is also described. Significance is given on designing an efficient antenna in accordance to the present wireless scenario and then the role of neural networks is described to optimize the performance of designed antenna. The conventional EM simulation methods to design antenna are complex and time consuming, so the importance of ANN is described in this chapter. A brief introduction about these techniques is given in next chapters.

Chapter 2

Literature Survey

In order to start the work, very first step is to study and analyze the research work that has been done earlier regarding the neural application in antenna modeling. The papers that are related to this title are chosen and studied. As described earlier Neural Networks are very efficient tool for optimization. In this field following research has been done by researchers:

Vilovic et al. [3] proposed design of using ANN optimized by PSO algorithm. Authors show ANN implementation in computing design parameters length(L) and width(W) with input parameters resonant frequency(f_r), substrate height(h) and dielectric constant(ξ_r) and RBFNN to obtain feed point distance(d).error minimization is done with modifying synaptic weights using PSO algorithm. The neural network model are implemented for given resonant frequency ($f_r=2.45$ GHZ), $h=1.588$ and $\xi_r=4.5$. The use of MLP and RBFANN takes few minutes in computations with high accuracy.

Kumar et al. [4] proposed design of multislot microstrip Antenna on 2mm thick substrate which is further optimized by application of GRNN, SVM and BFO ANN techniques. These techniques are used to calculate resonant frequency. Initially IE3D software is utilized to simulate the results for return loss, resonant frequency, radiation pattern and gain. The optimized results showed good agreement with the simulated results when compared. Estimation for resonant frequency by utilizing ANN and BFO is emphasized in this paper.

Lebbar et.al [6] proposed novel ANN based methodology in modeling microstrip patch antenna. The methodology presented is applicable to DCS, GSM, WLL, WLAN , broadband and planar techniques. Five applications of the methodology is presented, out of which 3 are applicable in WLL. 802.11 and 802.11b antenna standard and remaining two for broadband application. All antennas modeled by ADS technique radiates an end fire beam and have

compact size. The artificial neural network (GMBANN) found to give good performance in designing antenna for all five applications.

Neog et al. [10] proposed design of multislot hole coupled microstrip antenna to obtain wideband characteristics. Substrate chosen for design is 2mm. A tunnel-based artificial neural network (ANN) was utilized to estimate the radiation patterns of the antenna. The radiation patterns were measured experimentally at 10.5 GHz and 12 GHz. The simulated results were found in good agreement with the simulated results from IE3D and those of the artificial neural network. A new method of using a genetic algorithm (GA) in an artificial neural network is also discussed. The return loss and radiation patterns of the multiple-slot hole-coupled microstrip antenna presented in this paper clearly showed that the antenna is a wideband, multiple frequency antennas.

Mogadhassi et al. [12] presented the synthesis and analysis of rectangular microstrip fractal patch antenna based on the ANN model to find accurate value of resonant frequency. A MLP(multilayered perceptron) with backpropagation algorithm is used to estimate the resonant frequency. Out of 715 data sets 676 were used as training while 40 set were used as testing data. The input parameters were width(W), length(L), height(h) and dielectric constant (ϵ_r) and output parameter is resonant frequency(f_r). The estimated results were found in a good agreement with EM simulated and numerical results.

Dhaliwal et al. [13] proposed Neural network model to design the microstrip antenna. Three type of neural network (BPNN, RBF NN, GRNN) were developed and their performance analysis is done in order to parameter estimation of patch antenna. Number of iteration(N), and input feed locations x_i, y_i were used as input to the neural network and gain(G), return loss(S_{11}), resonant frequency (f_r). EM simulator IE3D was used to design patch antenna. GRNN showed the best performance in parameter optimization with minimum average MSE and minimum run time error.

Aneesh et al. [14] proposed design procedure of rectangular microstrip antenna using RBF-ANN. The resonant frequency of antenna with respect to the length is calculated with the

variation of maximum numbers of neurons .It required 21 neurons to get target frequency value. By using RBF significant amount of accuracy is achieved with less computational time. The resonant frequency of microstrip Patch has successfully determined with use of RBFNN.

Malmathanraj *et al.* [16] proposed to develop a neural network model to optimize the microstrip patch parameters. Firstly the analytical results for microstrip patch were obtained for different dimension and different radiation pattern, then these results were checked using EM simulating software. Then neural network was applied to optimize the parameter to get wide bandwidth and directivity with high gain. Thus ANN application ensured an optimum design methodology for designing of microstrip patch antenna.

Donnell *et al.* [17] proposed design of neural based beamformer to adapt low cost phased arrays. Aim for introducing this technique is to decrease the antenna manufacturing and maintenance cost. Developed ANN is utilized for the purpose of signal detection and DF(Direction finding). Firstly the simulated data was obtained using the conventional simulation, this data is used to train the a RBF network. Thus a RBF beamformer to approximate signal detection and DF is used in ideal and degraded conditions. However the results obtained were not as good as obtained from monopulse tracking, but the developed network showed good performance from the perspective of time efficiency and cost of antenna designing.

Angiulli *et al.* [18] proposed Neural fuzzy based network model to estimate the resonant frequency of microstrip antenna. The technique introduced is fruitfully in microwave CAD application. The data is generated from MOM (method of moments) EM simulation technique used to train the developed network. The predicted results were found in a good agreement with the EM simulated results for resonant frequency. The obtained rms error is found to be in acceptable range.

Narayana *et al.* [19] proposed a neural network model to optimize the microstrip patch parameters. Due to design complexity and non linearity between the input and output

parameters conventional EM simulation methods are not useful, Thus a RBF and MLP-BP neural networks were developed to mitigate this design problem. The ANN is used in two ways firstly synthesis is done then analysis. While synthesis of the network height(h), dielectric constant(ϵ_r) and resonant frequency(f_r) are the input parameters and length(l) and width(w) are the output parameters for the patch antenna. In synthesis process the RBF NN showed better efficiency while in analysis process MLP showed best performance.

Vakula et al. [20] proposed neural network modeling to find type of fault occurring in antenna array. The different fault that can occur in an array are on-off fault, current magnitude fault, phase fault and positional fault. These faults can lead to change in the array's radiation pattern. The antenna array consist of 101 elements is designed and diagnosed for proper functioning by observing changes in the radiation pattern. The input to the network is the Deviation pattern and the output is type of fault. The RBF and PNN are utilized to perform the task. The success rate found for all fault types is 100 %.

Chkraborty et al. [21] proposed a novel neural network based methodology to estimate the superstate loading effect on microstrip patch antenna. It is well known that loading effect makes considerable shift in the resonant frequency of the antenna. The neural network developed in the way adaptable to detect changes due to atmospheric deposition, icing effect etc. There were 280 data samples used to train the network and output were checked with that of simulated results obtained from IE3D simulation for change in frequency due to superstate effect. Results were found in good agreement with simulated results.

Thakare et al. [22] proposed a neural based approach to find out the bandwidth of a microstrip patch antenna. The training data was obtained from the IE3D EM simulator. The work presented investigate a new approach utilizing ANN for solving design problem of microstrip antenna. The network used is BP (back propagation) NN. Two sets of data were created one to train and other to test the trained network. The test results obtained for bandwidth were found in a good agreement with simulated results.

Milizic' et al. [23] proposed an efficient neural network model to approximate resonant frequency(f_r) and return loss parameter(s_{11}) for a slotted microstrip patch antenna. The patch with dielectric constant ($\epsilon_r= 2.4$) was designed using ADS 2006 EM simulation method and the data samples for training and testing are generated. The network developed was MLP-ANN. For the analysis of ANN performance the parameters WCE, ACE and r^{ppm} were discussed. The network was tested for 940 data samples. Neural predicted results for resonant frequency (f_r) and return loss parameter(s_{11}) were found in a good agreement with EM simulated results

Kumar et al. [24] proposed a novel neural based bandwidth enhancement method for microstrip patch antenna. A dual band patch antenna was designed to operate at 2.5 GHz frequency was designed using IE3D EM simulator. Antenna is driven by coaxial feed of 50 ohm. A MLP-ANN was developed for this purpose. The MSE of 10^{-8} was obtained in 300 epochs using this network. A wide bandwidth for a notch square patch was obtained by changing the interelement height and location of probe feeding. The neural results were in a good agreement with the EM simulated results for parameters estimation for notch square patch.

Bose et al. [25] proposed design optimization for aperture coupled microstrip antenna. The optimization was done with a hybrid neural model was developed by combining the properties of RBF and BP (back propagation) algorithms. Study reveals that time taken to develop individual BP network was very large but the error percentage is much less, while RBF network was developed in a few seconds but have large error, thus network developed by the hybridization of both network is efficient in terms of time taken and error percentage. According to author the significant advantage of network is that it completely bypass the iterative processes to new design presented to it with low error percentage and less computational time by proper training.

Singh et al. [26] proposed neural network development for rectangular microstrip patch antenna. The resonant frequency of antenna is estimated using four types of neural networks FFBN, RPROP (Resilient backpropagation), LM (levenberg marquardt) and RBF (radial

basis function) ANN. Networks are designed with four input parameters Length (l), width (w), dielectric constant (ϵ_r) and substrate thickness. Output is resonant frequency (f_r). Performance comparison is given in the presented work. RBF NN found to give best performance for optimization.

Tatuzov et al. [27] proposed a neural network system to mitigate the problems arise in designing of radar arrays because of lower flexibility of existing algorithms to poor flexibility and low computational capacity of traditional computers systems. ANNs can be utilized in radar information processing like phased array antenna weight adaptation, genetic algorithm for optimization of multibased coded signals, data association in multi target environment and neural making for decision making algorithms. Proposed method of using neural network showed considerable increase in efficiency of radar processing

Yazdanbakhsh et al. [28] proposed a design method for a monopole four square antenna array on a finite ground plane based on decoupling and matching network. The ground plane (chassis) affect strongly the mutual coupling of antenna elements. So to optimize the chassis size a neural network is modeled which leads to better results for decoupling network. The GA (genetic algorithm) is utilized with neural network for optimization. It transforms various parameters having data like antenna length, diameter, distance, chassis length, chassis height, neighboring decoupling capacitance/inductance and opposite decoupling capacitance to the admittance matrix of the array mounted on a finite ground plane assuming that decoupling network has less computational complexity.

Delgado et al. [29] proposed a novel ANN model for the parameter optimization of printed dipole antenna with balun and microwave device. The parameters taken were bandwidth, resonant frequency and VSWR (voltage standing wave ratio), further ANN is used to optimize width of microstrip transmission line with respect to line impedance. A new neural network is presented known as SYNTHESIS-ANN based on the hetero associative memory. Randomization of output is the most significant feature of this ANN, which provided significant time and cost savings. The results obtained from developed network were found in good agreement with computed results for parameters mentioned above.

Rafik *et al.* [30] proposed a novel neural based approach to describe design and optimization of a multi antenna system. It is necessary to keep isolation between the elements of antenna system in order to gain higher data rate (bandwidth) and better performance, a small change in the antenna structure or environmental changes lead to malfunctioning of the antenna system and the whole system is to be redesigned. The work presented in this paper showed the great advantage over conventional EM simulation methodology. The technique found useful for commercial PIFA (planar inverted fractal antenna) antennas which are used in mobile handsets.

Deluccia *et al.* [31] proposed neural network modeler to find out the optimal element position in non uniformly spaced broadband phased array. The ANN is used with a nature based algorithm GA (genetic algorithm). GA based NN was utilized for optimum element position for broadband array in order to minimize VSWR and side lobe level. The methodology has silent features of NN based driving point impedance estimation technique and a rapid pattern estimation technique mixed with a efficient GA optimizer. A 10-element stacked patch antenna was synthesized by this GA based neural network. The optimization is done for minimum SLL and element VSWR over a 60 degree scanning range and 10% bandwidth. The SLL remained under -10 db level over entire scanning range with much less average VSWR.

Zaharis *et al.* [32] proposed a neural based beamformer in order to steer the beam in the desired direction, to place the nulls in the direction of interference signal and to minimize the SLL. The data generated to train the neural network was obtained from MADIWO (modified adaptive dispersion invasive weed optimization). The proposed design was tested for different scenario of random interference signal and different power levels of AWGN. Optimal ANN was selected after training performance in different scenarios and the obtained results were compared to ADIWO based beamformers regarding their ability to maximize SINR and minimize the SLL. The radiation pattern analysis as well as statistical results showed that neural beamformer and MADIWO based beamformer give similar results.

Pelosi et al. [33] proposed a method for designing simplified coupling method using neural network approach. If there are large number of elements in an array than the mutual coupling effect cannot be neglected for a large scanning area and a full wave analysis has to be done for proper functioning of the array, which is unaffordable approach if number of elements increased in the array. To mitigate this problem ANN is utilized for desingning of coupling model because of its fast computations. The input to these network is the geometrical parameters of the array like inter element distance, length and diameter of array elements and the output were five coefficients of fourth order polynomial that fit the behavior of the module. Suitable set of simulation were carried out for each subarray and once the process is completed for all subarray the whole array was analyzed.

Somasiri et al. [34] proposed neural network modeler for dual band multilayer micristrip patch antenna. Authors optimized antenna using feedforward ANN model. The model shows good results and better accuracy over conventional EM simulations. The ANN model used to estimate first and second resonance frequencies with an accuracy comparable to EM model. Optimized antenna performs well in terms of bandwidth and size of the antenna is optimized as well.

Jain et al.[35] proposed design of dual band stacked patch antenna for X-Ku band by utilizing optimization feature of BFO algorithm and function mapping feature of ANN. Firstly ANN trained to learn the working frequency and then this trained ANN is embedded in the optimization loop of BFO. This optimizer is used to obtain the design parameters on the user defined frequencies. This developed methodology significantly lower down the simulation time with optimized feature.

Wnuk et al.[36] presented ANN model to get shaping profile(Radiation pattern) of microstrip antenna. Satisfactory results were obtained using appropriate number of hidden layer neurons. At the time of simulation radiation pattern is shaped in such a way that it attenuates the disturbing signal in the possible direction from it comes. Although this approach increases the level of complexity of system.

Anuradha et al.[37] proposed design of custom made fractal antennas using ANN and PSO techniques. The role of ANN is to form mapping between the design parameters and operational frequencies of Antenna.PSO is used to obtain the shape of antenna for the desired user defined frequencies. A joint utilization of ANN & PSO gives efficient result with less computational time.

Shang et al. [38] proposed RFID tag antenna optimization using ANN with PSO. They used Three layer MLP NN to model dipole antenna. The input parameter to NN is L, S, R, X where R and X are the real and imaginary part of impedance. Now optimization is done with GA and PSO combined with ANN. Which gives better results in agreement with simulated results and executed in less computational time. The Return loss function S_{11} is calculated.

Khan et al. [39] proposed a multilayered perceptron feedforward ANN model for calculation of parameters radius or side length. Parameter M, f, h, ξ , m, n are the input parameters to NN and Radius or side length is output. The obtained results shows good agreement with experimental results given in literature.

Vilovic et al. [40] proposed a neural based approach to design a circular patch antenna and estimate its feed position. The ANN utilized for the purpose is a RBF NN. On other side a MLP ANN is developed for measurement of physical and effective radius and directivity for 45 different microstrip antennas. The results obtained by neural network MLP model were compared with measured results available in the literature. The results obtained by RBF NN for input impedance are better with average MSE of 2.69.10. The neural predicted results were found in good agreement with measured results.

As described earlier that the work mainly concentrate on the two types of objectives. The first one is to design a square patch antenna and then to apply neural network on it. The second one concentrates on the designing of microstrip planar array and then utilization of neural network to estimate its directivity and SLL (Side Lobe Level). In this chapter the work is shown related to antenna designing only, work related for application of ANN on antenna is presented in the next chapter for both the objectives.

In the first objective the neural network is modeled to estimate the resonant frequency of a square microstrip patch antenna. So information regarding designing of a square should be known. Following section contains necessary aspects related to designing a square patch antenna. Information regarding planar array is discussed in the next section 3.2.

3.1 Basis for designing a Conventional Patch antenna

Prime aim of work is to study the effect of parametric variations of the geometrical dimensions on the resonant frequency of a microstrip patch antenna and the radiation pattern. The microstrip patch is a high frequency antenna composed of dielectric substrate, metallic patch, feed line and metallic ground plane. There are different shapes of patch antenna that can be utilized as per need. Most commonly used shapes are rectangular, circular, polygon, fractal, slotted hybrid fractal. The substrate used is commonly is FR-4 because of its cost effectiveness and ease of availability. In the proposed design also FR-4 substrate is used. Effect of fringing field is due to the metallic ground. Feeds are used to carry the signals from the connector to the patch. Use of different kind of feeds is also discussed for impedance matching.

3.1.1 Design of the square patch antenna

A square patch of 28 mm × 28mm is designed on the FR-4 substrate at the resonant frequency of 2.56 GHz. It is found that to obtain 50 ohms resistance the width of 3.04 mm

for microstrip line is appropriate to match with the 50 ohms connector. By using equation the edge impedance of the patch is found around 385 ohms..

Effective dielectric constant

The original value chosen for the dielectric constant cannot be considered for the analysis because its value tends to change due to the presence of a Quasi TEM mode. So the effective dielectric constant considering the presence of a quasi TEM mode can be given as

$$\epsilon_{r_{eff}} = \frac{\epsilon_r + 1}{2} + \frac{\epsilon_r - 1}{2} \left[1 + 12 \frac{h}{w} \right]^{-1/2} \quad (3.1)$$

Where ϵ_r dielectric constant or the relative permittivity of the substrate, h is is height of the substrate, w is width of the substrate.

Length of the Rectangular Patch

Resonant frequency for patch antenna mainly depends upon its length, for dominant mode length of antenna can be given as

$$L = \frac{C}{2f_r \sqrt{\epsilon_r}} \quad (3.2)$$

Where C is speed of light and f_r is resonant frequency for antenna.

The Impedance of coaxial feed can be given as

$$Z_0 = \frac{138}{\sqrt{\epsilon_r}} \log_{10} \left(\frac{D}{d} \right) \quad (3.3)$$

Where D is the outer diameter of the conductor in coaxial cable and d is the inner diameter of conductor. The inset feed position can be given mathematically as

Inset Feed position

$$Z_{in}(y = y_0) = Z_{in}(y = 0) \cos^2 \left(\frac{\pi}{l} \right) \quad (3.4)$$

Where l is the patch length.

3.1.2 Reflection coefficient analysis

The return loss graph with and without inset feed is shown in figure 3.2 for the proposed design. In this figure Y axis denote the magnitude of return power in db and X axis shows frequency variation in GHz. It can be observed that for antenna without inset feed there is not perfect matching between connector and antenna, while antenna with inset feed is able to obtain satisfactory matching below -10 db. Resonant frequency of 2.56 GHz can be observed from the figure 3.2.

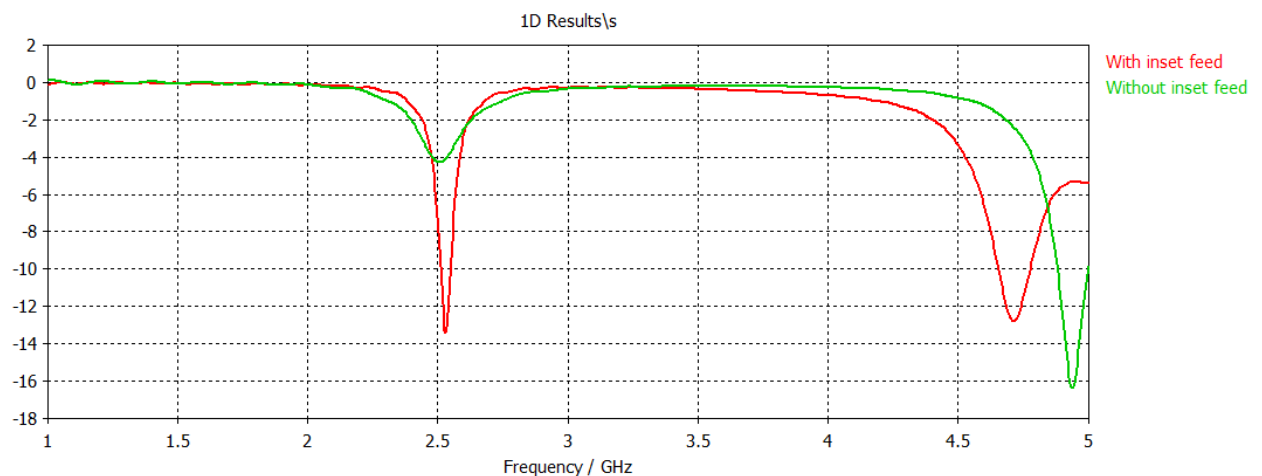

Figure3.1. $S_{11}(dB)$ versus frequency for with and without inset feed.

3.1.3 Design Specifications:

As described earlier a square microstrip patch is designed of 28mm.× 28 mm. dimension. A schematic diagram of the proposed design is shown below in figure 3.2.

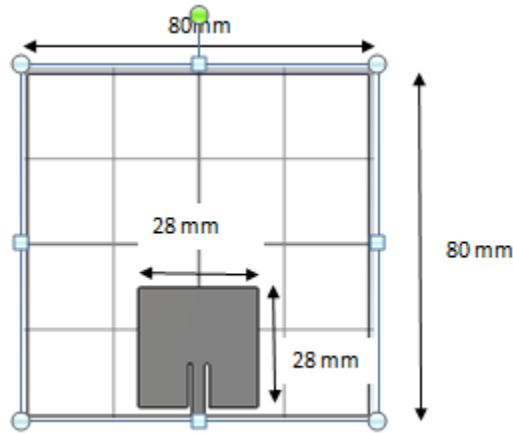

Figure3.2 Proposed Design for Square patch

3.1.4 Variation of parameters and data collection

After the designing of patch antenna with the desired characteristics values for the resonant frequencies are obtained for different length for the patch. This task is accomplished through the variation of length parameters by using a parametric sweep option to obtain corresponding resonant frequency. This EM simulated data is further applied to train the neural network.

Data set containing 20 samples is obtained through the CST software, shown in table

Table 3.1 Frequency at various length of patch

Length(L) in mm.	Resonant Frequency (f_r) in GHz
22	3.0694
22.63158	2.9921
23.26316	2.9215
23.89474	2.8476
24.52612	2.7809
25.15789	2.715
25.78947	2.6538
26.42105	2.5948
27.05263	2.5387
27.68421	2.4837
28.31579	2.4333

28.94737	2.3882
29.57895	2.335
30.21053	2.2896
30.84211	2.2471
31.47368	2.2045
32.10526	2.1627
32.73684	2.1213
33.36842	2.0855
34	2.0491

3.2. Basics for planar array

To obtain higher degree of freedom from array design perspective antenna elements can also be placed in the grid formation, the structure thus obtain is known as planar array. The key advantage of using planar array is more versatility in beamforming capabilities and SLL cancellation. Basic structure of $M \times N$ planar array is shown in figure 3.4.

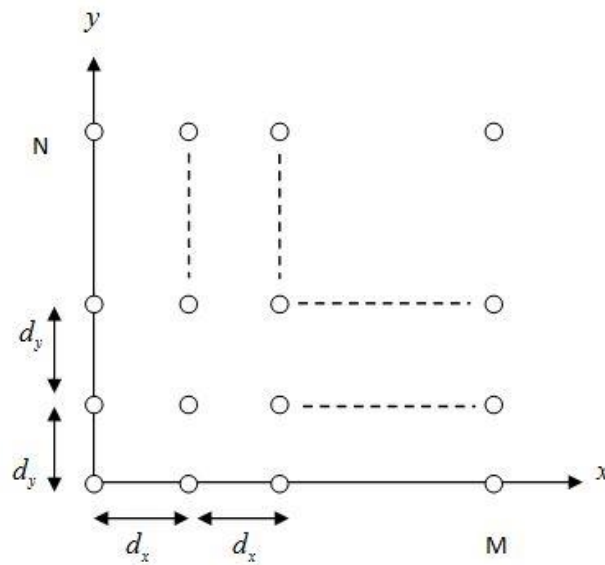

Figur3.3 Basic structure of Planar Array

The radiating elements are placed along the x axis and the y axis. The array factor for M elements along the x axis can be expressed

$$af_x = \sum_{m=1}^M I_{m1} e^{j(m-1)(kd_x \sin \theta \cos \phi + \beta_x)} \quad (3.5)$$

Where I_{m1} is the individual element's excitation coefficient on the x axis and β_x is the phase excitation difference between the elements. Now the same kind of linear array can be placed along y axis, the resulting af is expressed as:

$$af = \sum_{n=1}^N I_{n1} \left[\sum_{m=1}^M I_{m1} e^{j(m-1)(kd_x \sin \theta \cos \phi + \beta_x)} \right] e^{j(n-1)(kd_y \sin \theta \sin \phi + \beta_y)} \quad (3.6)$$

Applying the same concept used in (2.61), the individual array factor for the y-axis is:

$$af_y = \sum_{n=1}^N I_{n1} e^{j(n-1)(kd_y \sin \theta \sin \phi + \beta_y)} \quad (3.7)$$

The total af can be expressed as

$$af = af_x af_y \quad (3.8)$$

So we can say that the af for any planar array is the product of individual linear array along both axis. Assuming excitation factor for different array same i.e. $I_{m1} I_{n1} = I_{mn} = I_0$ and using trigonometric properties equation 3.6 can be rewritten as

$$af = \left[\frac{\sin\left(\frac{M}{2} \varphi_x\right)}{\sin\left(\frac{\varphi}{2}\right)} \right] \left[\frac{\sin\left(\frac{N}{2} \varphi_y\right)}{\sin\left(\frac{\varphi_y}{2}\right)} \right] \quad (3.9)$$

Where

$$\varphi_x = kd_x \sin \theta \cos \phi + \beta_x$$

$$\varphi_y = kd_y \sin \theta \sin \phi + \beta_y$$

3.2.1. Designing of array

As discussed earlier a 2×2 microstrip planar array is designed using a CST microwave studio. Two elements are placed along x axis and two along y axis as discussed in the above section. Each element has dimension of $28\text{mm} \times 28\text{mm}$. The designed array resonates at 2.4 GHz. The phase shift of 90° is provided between the two consecutive elements in order to reduce the effect of mutual coupling coefficients, which results in enhancement in array performance in context of its radiation characteristics.

Operating wavelength for the array is 120 mm. After designing the array numbers of readings are obtained for its radiation characteristics. Directivity and SLL (side lobe levels) are computed at different inter element distance of the array. Around 240 readings are obtained, which are shown in table 4.4 in next chapter.

3.2.2 Specification of designed array

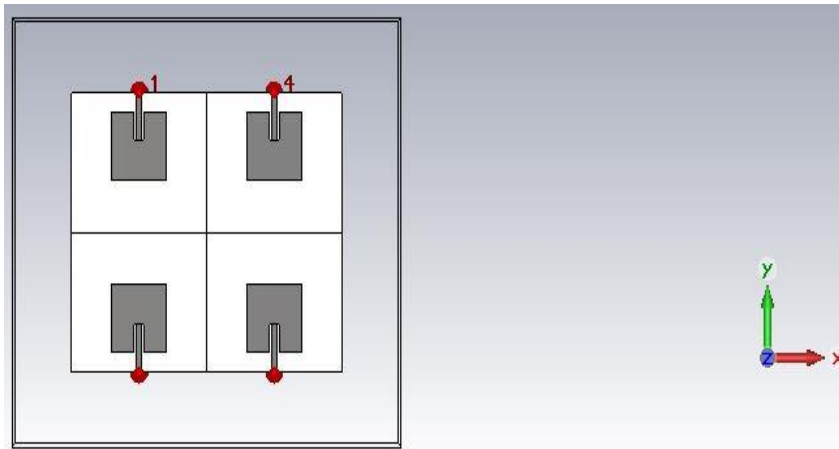

Figure 3.4 Proposed design for planar array

Table 3.2 Parameter specifications for planar array

Parameter	Value
Height	1.6 mm.
Substrate thickness	1.59 mm
Dielectric Constant	4.3

Resonant frequency	2.4 GHz
Operating wavelength	120 mm

3.3 Summary

The chapter presented necessary equations to design patch antenna and planar array. The use of the CST microwave studio is shown in designing. Analysis of the proposed design is discussed in terms of reflection coefficient, effect of different feed for the patch. A proposed design for patch is shown in figure 3.4 and planar array in figure 3.5. The total of 20 samples for resonant frequency at different length of patch and 240 samples for Directivity and SLL are computed from the CST tool.

This chapter basically deals with the brief introduction regarding the neural network. This chapter describes basic ANN model and the methodology used to optimize the antenna parameters and obtained results after optimization for the proposed design. The key issue is to understand the working of neural network utilized for the optimization purpose. Basically two types of ANN are utilized in the optimization 1) Feed Forward net 2) RBF neural net. These two types are mainly discussed in this chapter.

4.1 ANN Model

A mathematical model of a biological neuron is shown in the figure 4.1. The dendrites are represented by the input nodes P_r , information collection sent from other nodes and modification in it is done by synaptic weight. Activation function shown in the diagram works as cell body which collects and process the gathered information and the output information is to be transmitted to other neurons through the axon, is represented by $f(z)$.

The ANN can only be used till there exist a correlation between input and output to model relationship between them, the utility of ANN comes to an end if there is no correlation such as random events. Mathematical models used in the ANN are numerical approximation, which are not suitable for applications where the output must be exact as accepted, with no margin of error. There are a lot of applications where ANN can be utilized as an efficient tool such as prediction, pattern recognition and optimization.

The mathematical model shown in figure 4.1 is also known as The McCulloch pits model and the output for it can be given as

$$y = f(w_1 \cdot p_1 + w_2 \cdot p_2 + w_3 \cdot p_3 + \dots + w_R \cdot p_R + b) \quad (4.1)$$

$$y = f(w \cdot p + b) \quad (4.2)$$

$$y = f(z) \quad (4.3)$$

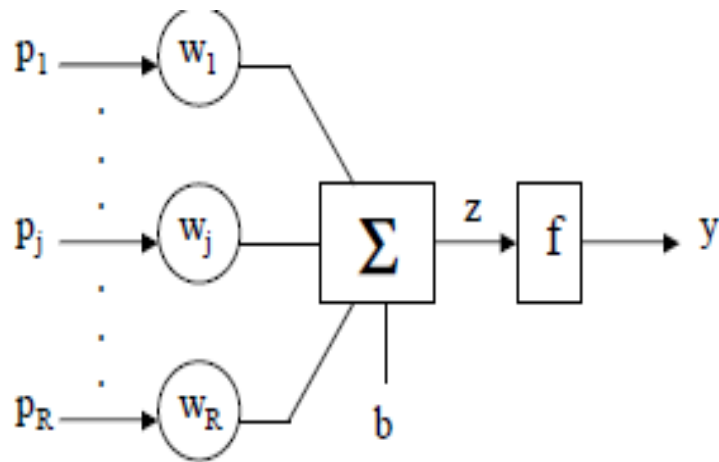

Figure 4.1 ANN Structure

Where

$p = (p_1, p_2, \dots, p_R)$ is the input vector

$w = (w_1, w_2, \dots, w_R)$ is the weight vector

Where p_i and w_i are the input and weight vectors respectively. The McCulloch and Pitts model was the first model introduced in 1943, required proper selection of weight values from the user to function. This model was not efficient since the weight selection on the basis of ad-hoc style (trial and error), and weight would become fixed after the selection. So this model had lack of adaptability. After that perceptron model was introduced by Frank Rosenblatt in 1958, which was based on a learning algorithm, allowing the network taking random weights initially and later adapt in accordance with the learning algorithm based on the desired values of output to the corresponding input value. Later in 1960 adaline model was introduced by Widrow and Hoff, much similar as of perceptron model with some differences.

Perceptron model used unit step function as the activation function, which produce output 1 or 0 on the basis of vector z .

$$F(z) = \begin{cases} 0, & z < 0 \\ 1, & z > 0 \end{cases} \quad (4.4)$$

While the adaline model uses signum function as the activation function.

$$F(z) = \begin{cases} -1, & z < 0 \\ +1, & z > 0 \end{cases} \quad (4.5)$$

In order to adapt the initial weights to more desirable values, first an error E is calculated based on the target output values. For the perceptron model, the error is calculated using the output.

$$E = d - y = d - f(z) \quad (4.6)$$

For adaline model error is calculated as

$$E = d - z \quad (4.7)$$

After the error calculation the the weights are adjusted in the same manner for the both networks

$$W_i[t+1] = W_i[t] + \alpha EP_i \quad (4.8)$$

Where $W_i[t+1]$ the weight is vector for the current iteration and $W_i[t]$ is the weight vector for the previous iteration. α is the learning rate that is defined by the user having value greater than zero. The error process is repeated till the value of error become zero or reaches user defined value or maximum number if iteration is reached. The user defined value for error is set to very small value approaching to zero. The utility of perceptron and adaline model was limited to linearly separable problems, as the complexity between input and output data samles increases these networks failed to converge to an acceptable solution. This problem was overcome by adding additional layers of the neurons to the networks lead to introduction of MLP (multi layered perceptron) and madalines in place of adalines.

4.1.1 Some transfer functions “f”

- Hard Limit:

$$y(z) = \begin{cases} 0, & z < 0 \\ 1, & z > 0 \end{cases}$$

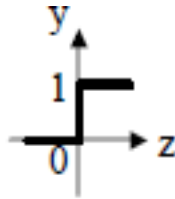

(a)

- Symmetrical Hard Limit:

$$y(z) = \begin{cases} -1, & z < 0 \\ +1, & z > 0 \end{cases}$$

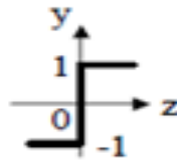

(b)

- Log-Sigmoid :

$$y(z) = \frac{1}{1 + e^{-z}}$$

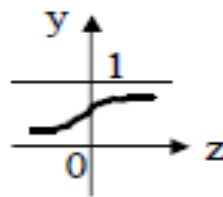

(c)

- Linear: $y = z$

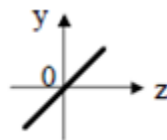

Figure 4.2 Different Transfer (Activation) Functions

4.1.2 Advantages of ANN

- Massive Parallelism
- Distributed representation
- Learning ability
- Generalization ability
- Fault tolerance

4.1.3 Limitations of ANN

- Like any data driven model they cannot be applied if there is no or very little data.
- There are many free parameters such as the number of hidden layers, learning rate, minimal error which may greatly affect the final results.
- They do not provide explanations.

4.2 Feed Forward Backpropagation Net

As the name shows these are the feed forward networks with backward flow or some type of feedback, in which the input vector flows in forward direction from input to the output side to produce output vector. At output side a error signal vector is generated (which is the difference between Desired and predicted output) flows backwardly from output side to input side in order to update the weights and make neural network adaptive to obtain the desired results. Back propagation networks are trained with unique algorithms, which use the partial derivative of the activation function at each layer. The generalized architecture for a MLP-ANN (Multilayered Feedforward Net) is shown in Figure 4.3. These networks can be modeled with many numbers of layers, but generally MLP-ANN with two or three layers is preferred in most of the applications. Network shown in Figure 4.3 has two layers one hidden layer and one output layer. In the shown architecture there are i total number of inputs, j neurons in the hidden layer and k number of total output. There are $j \times k$ weights at the output layer. The key property regarding the activation function of the hidden layer in this network is that they do not use the unit step and signum activation function as were in case of perceptron and adaline model because they are not differentiable at all points.

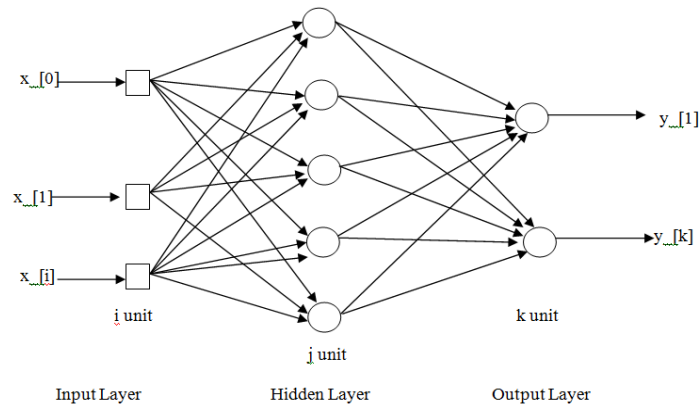

Figure4.3 MLP Feed-Forward Architecture with BP

Feedforward net uses log sigmoid and tan sigmoid activation function, which gives better results due to property of differentiability. The log sigmoid function can be described as

$$F(net) = \frac{1}{1 + e^{-k*net}} \quad (4.9)$$

Where k is scaling factor. Similarly the tan sigmoid function can be given as

$$F(net) = \frac{2}{1 + e^{-k*net}} - 1 \quad (4.10)$$

By controlling the value of constant k, log sigmoid and tan sigmoid function would approach to the response of unit step and sigum function.

4.2.1 Back propagation training

The training process in BP training can be subdivided into two sections: the forward pass and the reverse pass. But before training process suitable number of hidden neurons and adequate activation function should be chosen. Hidden neurons in excess can result in over fitting of the dat and slow response, whereas lesser neurons in hidden layer may results in under fitting of data and the network would not converge to desired results. There are many thumb rules exist regarding selection of number of hidden neurons such as using the number of input and output as references, although rule of thumb only gives the starting point and are by no

means apply restrictions. Therefore selection of hidden neurons is done in an ad hoc manner. By observing the expected output with respect to variation in the input, a better selection of number of hidden neurons as well as proper activation function can be made.

In the forward pass the output is obtained as a function of weighted inputs, as discussed earlier in the generalized neuron model of figure 4.1. However the theory described in the figure 4.1 is for single layer, single neuron, the concept can be extended to two layers as shown in figure 4.3. In this approach there are two outputs, one for the hidden layer having j outputs that is $f_j(net)_{hidden}$ and the second one is of output layer having k number of outputs that is $f_k(net)_{output}$, which is considered as the output of the entire network. At this time the forward pass ends and the reverse pass starts.

The reverse pass is initiated by the calculating the error vector between expected and the generated outputs as shown in equation 1.26. Thus the error generated is used to update the weights from the output layer to the hidden layer. In a similar manner to which weights were updated earlier in equation 4.8 weights are updated at the output layer for the figure 4.3.

$$W_{jk} [t + 1] = W_{jk} [t] + \lambda (\delta_k f (net)_{hidden}) \quad (4.11)$$

Where δ_k is defined as product of error and the partial derivative of the output layer activation function.

$$\delta_k = E \times \frac{\partial (f (net)_{output})}{\partial net} \quad (4.12)$$

After the updating the output layer weights, the hidden layer weights are updated as

$$W_{nj} [t + 1] = W_{nj} [t] + \lambda (\sum \delta_j p_n) \quad (4.13)$$

Where δ_j is defined as product of partial derivative of hidden layer activation function and sum of the initial output layer weights with δ_k .

$$\delta_j = (\delta_k W_{jk} [t]) \times \frac{\partial (f(\text{net})_{\text{hidden}})}{\partial \text{net}} \quad (4.14)$$

After the updating the weights of hidden layer neurons, the reverse pass ends and forward pass begin again, when the updated weights of the hidden layer are computed, the reverse pass ends and forward pass begins again, thus repeating the training cycle. In this way completion of one full training cycle is known as the epoch. Training is repeated until either a fixed epoch has been reached, or error obtained falls below a preset tolerance value, whose value is typically set close to zero.

4.2.2 BP Simulation

After the training phase the network capabilities are being tested to approximate the function which is used to modeled by ANN. This phase is known as testing phase. In this phase the data set used for testing is unknown to the network. For the simulation of BP network only forward pass is required, since the weights should be set at this point. The network is then fed with equal or larger set of input in compare to training phase. The outputs are generated and compared to desired values. Although for the simulation part individual error are observed instead of average error, due to the fact of the necessity of minimize the error for every input pattern. The ability of network to generalize the results is tested by using the input patterns that were not used during the training phase. If the calculated error is unacceptable, then the training is done by varying the different set of training parameters like to change the number of neurons in the hidden layer, error threshold, learning rate etc.

4.3 Radial Basis Function Networks

This is the second type of ANN that is to be discussed in this chapter. It is another variant of feed forward ANN first applied in neural networks by Broomhead and Lowe [31] and have gained a lot of popularity in recent years for approximate the nonlinear functions. It has e same basic architecture as of feed forward net, with the difference that they uses radial basis neurons in the hidden layer. The RBF ANN model architecture is shown in figure4.3. Although RBF NN is a type of feed forward net, they show noticeable differences from the BP network in terms of computed output and the way network is trained. Function net for

the BP network was calculated using the sum of the weighted inputs whereas net function for RBF network is calculated based on the Euclidean distance between the input and weights.

$$net = w - p \quad (4.15)$$

The activation functions of the RBF hidden layer is the Gaussian function. The final output $f(net)$ is calculated in terms of the Euclidean net as

$$f(net) = e^{-(.8326*net/s)^2} \quad (4.16)$$

Where s is user defined spread constant. Equation 4.16 shows that when the input vector is equal to the weight vector the output $f(net)$ attains its maximum value, while the difference between weight vector and the input vector increases, the output $f(net)$ approaches to zero. Transfer function for the output layer is linear function as described earlier in equation 4.1.

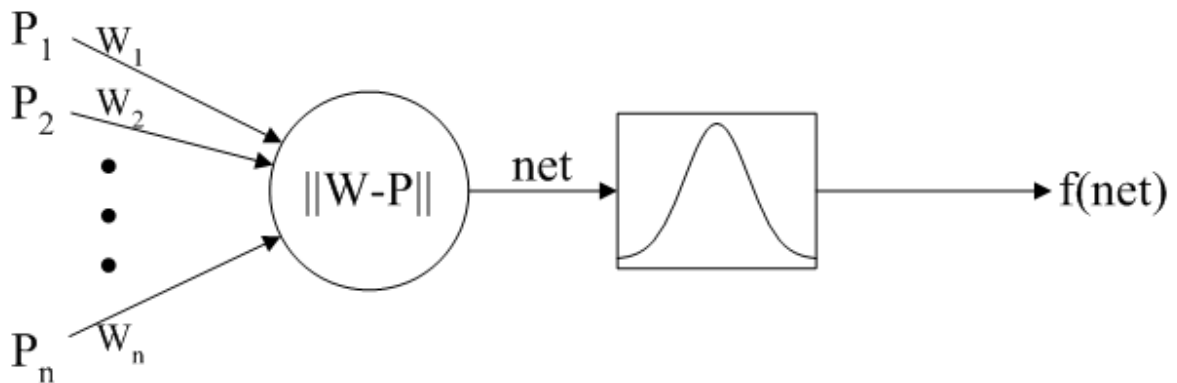

Figure 4.4 RBF ANN Structure

4.3.1 RBF Training

While comparing with BP training process RBF, does not have an actual training process. These networks have very simple process for weight adjustment and the number of neurons in the hidden layer. The number of the training sets matches to the number of the weights in the hidden layer and values of the hidden layer weights set equal to the input pattern, which leads to result in the maximum output when the input values are equal to the training

patterns. To obtain the desired output from the RBF NN weights and biases values are set in a manner that the generated values of output match the desired output values exactly. Here the significance of the spread parameter s should also be discussed. It is a constant used to control the individual RBF neuron's field of response that restricts the modeled function such that its value does not go to zero for any point between training input patterns. Individual weights for the hidden layer are set in accordance to the input pattern values.

The individual weights and biases for the output layer are found in terms of the target output values by using equation given below

$$W_{jk}f(net) + b = y_{jk} \quad (4.17)$$

4.3.2 RBF Simulation

As discussed above the way in which a RBF network is trained, training process is completed in a single epoch as compared to complex iterative process in BP network. Now comes the next important step of testing process or simulation process, in which network's ability to approximate the input value is checked from the input pattern that is not used in the training phase. During the simulation phase error between the desired and simulated output is computed. If the error value obtained is not satisfactory, the network must be retrained. If the number of neurons weights in the hidden layer is changed, the number of training patterns should also be changed to match. While retraining, the most significant parameter which needs to be changed is the spread constant of RBF network. As discussed earlier they defines the field of response for the hidden layer neurons, this field of response should be large enough to approximate the output values for the network, but not so large that causes over fitting problem.

4.3.3 Summary

In this chapter the basic introduction about neural model and different neural techniques that are utilized in this thesis are discussed. Methodology regarding feedforward and RBF neural networks for optimization of patch parameters and radiation characteristics of antenna array is presented. Emphasis is given on to understand the operation of both the ANNs in

optimization. Difference between the working of two neural nets is discussed. The feedforward net with BP algorithm utilizes the concept of feedback to update the weights on the basis of error signal generated and the RBF NN produces output on the basis of Euclidean distance between the weight vector and input vector.

As discussed earlier the work is divided into the two objectives. The first one is application of neural network in estimation of resonant frequency for a square patch and the second one is the utilization of neural networks in estimation of directivity and side lobe level of a microstrip planar array. Results corresponding to each objective are discussed in this chapter.

5.1. Optimization of Patch parameters using RBF ANN

A RBF ANN is utilized to estimate the resonant frequency of the microstrip patch for different length. For this purpose a RBF network is generated in MATLAB environment. This network is then trained by EM simulated data obtained from the CST software. There are total of 20 data samples of resonant frequency with respect to length shown in table 3.1. Out of these 20 samples 12 samples are used to train the network while 8 samples are utilized for the testing purpose shown in table 5.1.

Table 5.1. Test data set for RBF NN

Length(mm)	Frequency(GHz)
22	2.9921
23.89474	2.8476
25.15789	2.715
26.42105	2.5948
27.68421	2.5948
30.21053	2.2896
31.47368	2.2045
32.73684	2.1213

The results are simulated for different number of neurons in the hidden layer, to find best possible output matching the desired output.

Initially RBF ANN is developed with the following specification

Table 5.2 RBF Specifications

Parameter	Value
Goal	.001
Spread Constant	1
Df	1

With the parameters defined in table 5.2 RBF is trained with different numbers of neurons in the hidden layer.

Initially a RBF is created with one neuron in the hidden layer. The MSE achieved through this network is .0994682 and it does not give good results for estimated frequency. Now keeping all other parameters same a new network is developed using two neurons in the hidden layer, this time MSE achieved is .0504701, performance for this network is shown in figure 5.1.

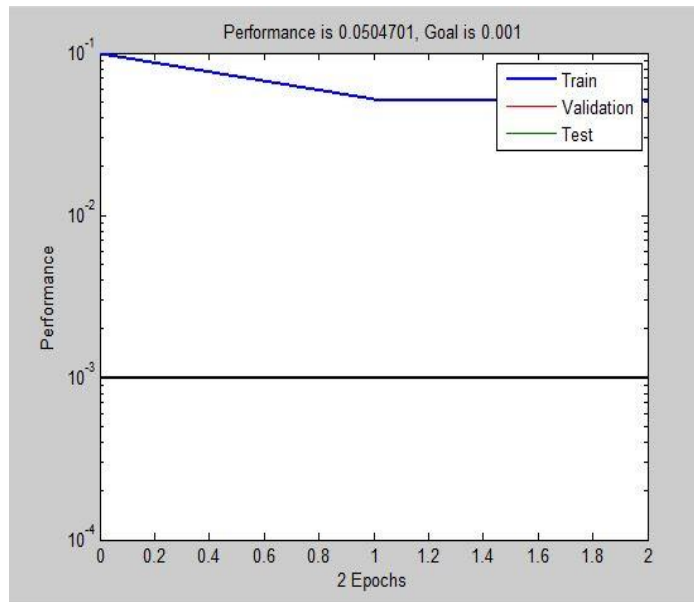

Figure 5.1 RBF performance plot for 2 hidden layer neurons

Now number of hidden layer neurons is increased to five. This time MSE achieved is 0.0167094, performance plot for this network is shown in figure 5.2.

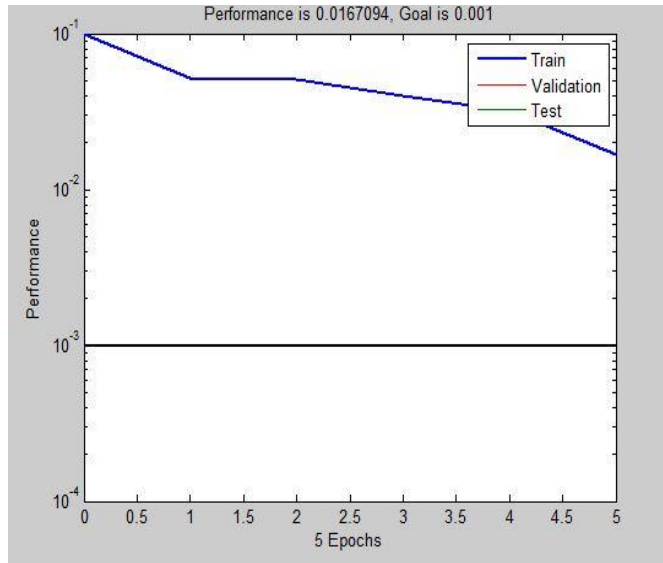

Figure 5.2 RBF Performance plot for 5 hidden layer neurons

Finally network is developed using eight hidden layer neurons, this network best approximate the estimated frequency with MSE of 0.000504239. The performance plot is shown in Figure 5.3.

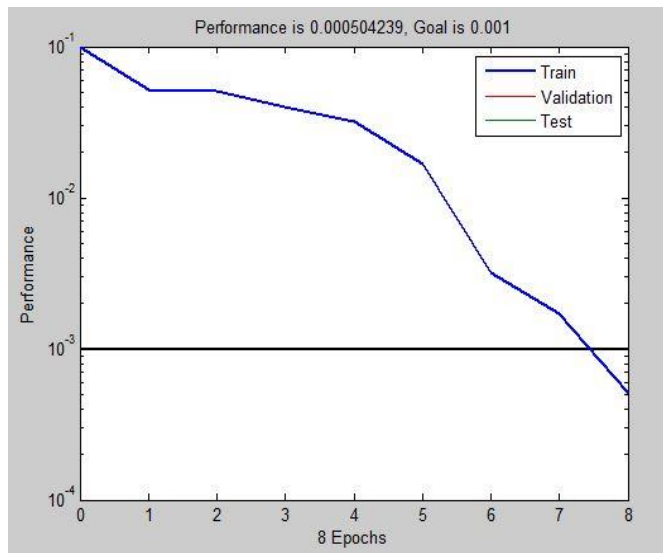

Figure 5.3 RBF Performance plot for 8 hidden layer neurons

Plot for MSE with respect to different number of neurons in the hidden layer is shown in figure 5.4. It can be observed that minimum value of MSE is achieved for 8 number of neurons in the hidden layer. Results for MSE in tabular form are shown in table 5.3.

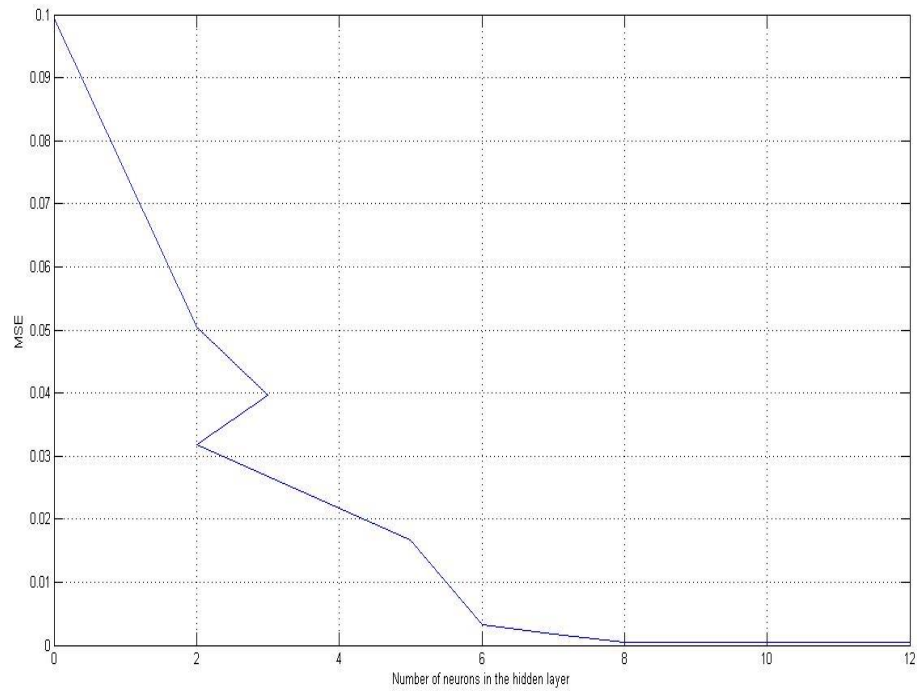

Figure 5.4 MSE with respect to different number of neurons in the hidden layer for RBF- NN

Table 5.3 MSE with respect to different number of neurons in the hidden layer for RBF ANN

No. of hidden layer neurons	MSE
0	0.0994682
2	0.0504701
3	0.0395838
4	0.0317578
5	0.0167094
6	0.00318884
7	0.00171669
8	0.000504239
9	0.000504239
10	0.000504239

11	0.000504239
12	0.000504239

In the work presented here for the patch parameter optimization using RBF ANN, as the number of neurons in the hidden layer are increased the network adapts the weights efficiently in order to minimize the error. It can be observed that as number of neurons in the hidden layer is increased the performance goal for the network improves significantly. RBF network with 8 neurons in the hidden layer shows the best performance with MSE of 0.000504239 (lower than the set goal of .001). So this network best approximate the resonant frequency for the patch. So the RBF NN with 8 hidden layer neurons is the optimized network for the estimation of resonant frequency at different lengths of patch. It is found that further increase in hidden layer neurons do not show any effect on MSE, network with 8 neurons in the hidden layer is found most efficient network. Obtained results in tabular form are shown in table 5.4. Plot for predicted resonant frequency at different length of patch with respect to different neurons in hidden layer are shown in figure 5.4.

Table5.4. Neural estimated frequencies

Length (mm)	Frequency (GHz)	Predicted Frequency (GHz)
22.63158	2.9921	3.05223478323540
23.89474	2.8476	2.82510665992666
25.15789	2.715	2.73510281116976
26.42105	2.5948	2.57744604188649
27.68421	2.5948	2.43616009284083
30.21053	2.2896	2.30785385214506
31.47368	2.2045	2.18003832580825
32.73684	2.2045	2.15487861416734

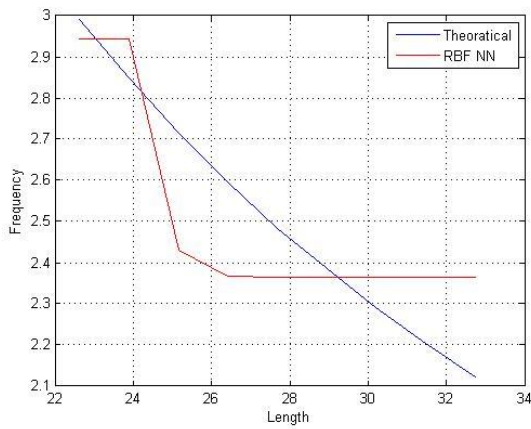

(a) RBF output with 1 neuron in hidden layer

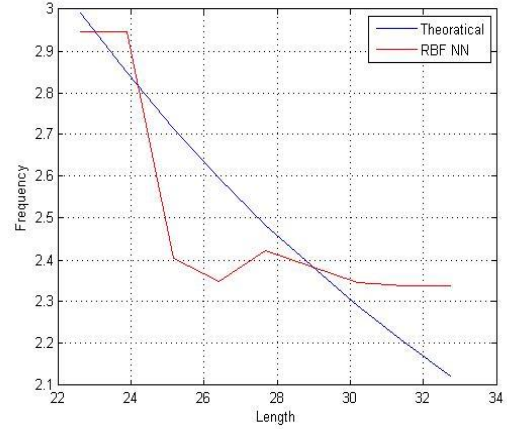

(b) RBF output with 2 neurons in hidden layer

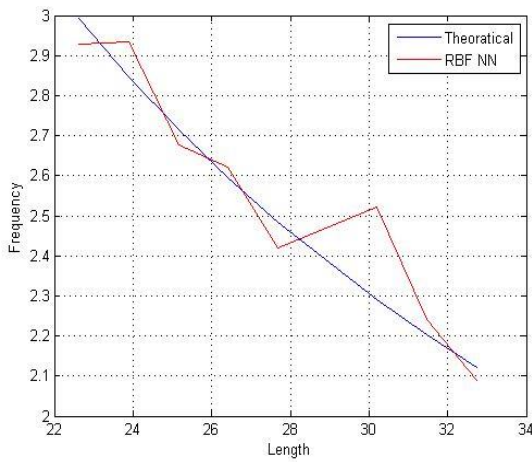

(c) RBF output with 5 neurons in hidden layer

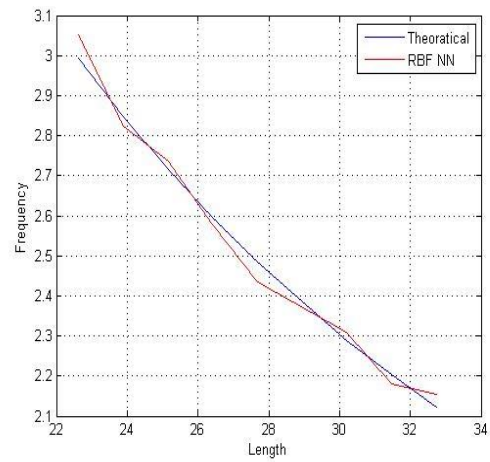

(d) RBF output with 8 neurons in hidden layer

Figure 5.5 RBF output with respect to different neurons in the hidden layer

5.2. Neural application on planar array

As discussed in previous chapters a 2×2 microstrip planar array is developed and various types of neural techniques are applied in order to estimate /model the Directivity and SLL (Side Lobe Level) of the array. Planar array is designed and its radiation pattern characteristics (Directivity and SLL) are obtained for different normalized inter element

spacing (d/λ) using CST simulation software. The obtained values for Directivity and SLL are shown below in table 5.5 The value of λ for the designed array is 120 mm.

Table 5.5 CST simulated Directivity and SLL with respect to distance

Distance(d)	d/λ	Directivity(D)	SLL
7	0.0583	3.149191	-7.9861
7.1759	0.0598	3.110682	-8.01136
7.3518	0.0613	4.057333	-8.72693
7.5276	0.0627	4.074959	-8.75105
7.7035	0.0642	4.088819	-8.77513
7.7143	0.0643	4.089693	-8.77656
7.8794	0.0657	4.102002	-8.79869
8.0553	0.0671	4.115514	-8.82459
8.2312	0.0686	4.126396	-8.84773
8.407	0.0701	4.138338	-8.87231
8.4285	0.0702	4.139464	-8.87507
8.5829	0.0715	4.147159	-8.89477
8.7588	0.073	4.155049	-8.91703
8.9347	0.0745	4.16203	-8.9391
9.1106	0.0759	4.168117	-8.96102
9.2864	0.0774	4.175111	-8.98281
9.4623	0.0789	4.18177	-9.00449
9.6382	0.0803	4.186653	-9.02647
9.8141	0.0818	4.191554	-9.04672
9.8571	0.0821	4.192711	-9.0547
9.9899	0.0832	4.195503	-9.0694
10.1858	0.0849	4.198596	-9.08881
10.3417	0.0862	4.201047	-9.1082
10.5176	0.0876	4.202942	-9.12756
10.5714	0.0881	4.203413	-9.13349

10.6934	0.0891	4.204328	-9.14693
10.8693	0.0906	4.20527	-9.1663
11.0452	0.092	4.2059	-9.18569
11.2211	0.0935	4.206303	-9.20508
11.397	0.095	4.206356	-9.22454
11.5729	0.0964	4.20624	-9.24405
11.7487	0.0979	4.203314	-9.26299
11.9246	0.0994	4.203178	-9.28283
12	0.1	4.20314	-9.29135
12.1005	0.1008	4.203103	-9.30274
12.2764	0.1023	4.203138	-9.32273
12.4523	0.1038	4.20382	-9.34278
12.6281	0.1052	4.205472	-9.36291
12.7143	0.106	4.206383	-9.3728
12.804	0.1067	4.207408	-9.3831
12.9799	0.1082	4.209697	-9.40335
13.1558	0.1096	4.212367	-9.42365
13.3317	0.1111	4.215484	-9.444
13.4286	0.1119	4.217413	-9.45523
13.5075	0.1126	4.219087	-9.46438
13.6834	0.114	4.219133	-9.48588
13.8593	0.1155	4.22385	-9.50592
14.0352	0.117	4.229191	-9.52596
14.2111	0.1184	4.235201	-9.54599
14.3869	0.1199	4.241891	-9.56602
14.5628	0.1214	4.721862	-9.51888
14.7387	0.1228	4.729415	-9.53049
14.8571	0.1238	4.734771	-9.5383
14.9146	0.1243	4.73734	-9.54209
15.0905	0.1258	4.745119	-9.55367

15.2163	0.1268	4.752774	-9.56526
15.4422	0.1199	4.241891	-9.57684
15.5714	0.1214	4.721862	-9.58536
15.6181	0.1228	4.729415	-9.58844
15.794	0.1238	4.734771	-9.60004
15.9698	0.1243	4.73734	-9.61167
16.1457	0.1258	4.745119	-9.62331
16.2857	0.1268	4.752774	-9.63495
16.3216	0.1287	4.760314	-9.63729
16.4975	0.1298	4.765787	-9.64876
16.6734	0.1302	4.767751	-9.66026
16.8492	0.1316	4.775107	-9.67179
17	0.1331	4.782407	-9.68171
17.0251	0.1345	4.789652	-9.68336
17.201	0.1357	4.792298	-9.69499
17.3769	0.136	4.793735	-9.70665
17.5528	0.1375	4.800787	-9.71838
17.7143	0.1389	4.807844	-9.72921
17.7286	0.1404	4.814923	-9.73018
17.9045	0.1417	4.821025	-9.74204
18.0804	0.1419	4.822049	-9.75397
18.2563	0.1433	4.829232	-9.76598
18.4286	0.1448	4.836477	-9.7792
18.4322	0.1463	4.843807	-9.77945
18.608	0.1476	4.850623	-9.79187
18.7839	0.1477	4.851232	-9.80438
18.9598	0.1492	4.85877	-9.817
19.1357	0.1507	4.866423	-9.82972
19.1429	0.1521	4.874211	-9.83024
19.3116	0.1536	4.879288	-9.84255

19.4874	0.1536	4.879451	-9.85549
19.6633	0.1551	4.887582	-9.86856
19.8398	0.1565	4.895869	-9.88176
19.8571	0.158	4.904328	-9.88312
20.191	0.1595	4.912958	-9.90856
20.3668	0.1595	4.913312	-9.92218
20.5427	0.1609	4.921772	-9.93595
20.5714	0.1624	4.930773	-9.93821
20.7186	0.1639	4.939963	-9.94987
20.8945	0.1653	4.95896	-9.96395
21.0704	0.1655	4.950332	-9.97821
21.2462	0.1683	4.968767	-9.99264
21.2857	0.1697	4.958787	-9.99591
21.4221	0.1712	4.989028	-10.0061
21.598	0.1714	4.990717	-9.91655
21.7739	0.1727	4.999483	-9.93059
21.9497	0.1741	5.010158	-9.92941
22	0.1756	5.021057	-9.92058
22.1256	0.1771	5.032181	-9.89863
22.3015	0.1774	5.034702	-9.86812
22.4774	0.1785	5.038956	-9.83937
22.6533	0.18	5.300127	-9.8094
22.7143	0.1814	5.308798	-9.79906
22.8291	0.1829	5.317458	-9.77969
23.005	0.1833	5.319924	-9.75027
23.1809	0.1844	5.326095	-9.71914
23.3568	0.1858	5.334715	-9.68786
23.4286	0.1873	5.339796	-9.67516
23.5327	0.1888	5.348458	-9.65682
23.7085	0.1893	5.351463	-9.62603

23.8844	0.1902	5.357118	-9.59548
24.0603	0.1917	5.365785	-9.56519
24.1429	0.1932	5.374442	-9.55106
24.2362	0.1946	5.383101	-9.53516
24.4121	0.1952	5.386636	-9.50537
24.5879	0.1961	5.391763	-9.47584
24.7638	0.1976	5.400427	-9.44657
24.8571	0.199	5.409098	-9.43114
24.9397	0.2005	5.417772	-9.41755
25.1156	0.2012	5.421846	-9.38878
25.2915	0.202	5.426461	-9.36026
25.4673	0.2034	5.43515	-9.33224
25.5714	0.2049	5.443849	-9.31553
25.6432	0.2064	5.452555	-9.30407
25.8191	0.2071	5.457181	-9.27615
25.995	0.2078	5.46127	-9.24848
26.1709	0.2093	5.469999	-9.22105
26.2857	0.2108	5.478735	-9.20326
26.3467	0.2122	5.483933	-9.19386
26.5226	0.2131	5.489353	-9.16692
26.6985	0.2137	5.493093	-9.14021
26.8744	0.2152	5.502279	-9.1136
27.0503	0.2166	5.511497	-9.08739
27.2261	0.2181	5.520752	-9.06141
27.402	0.219	5.527361	-9.03565
27.5779	0.2196	5.531017	-9.0101
27.7143	0.221	5.541592	-8.99044
27.7538	0.2225	5.552221	-8.98477
27.9296	0.224	5.559747	-8.95965
28.1055	0.2254	5.570571	-8.93472

28.2814	0.2269	5.581445	-8.90999
28.4286	0.2284	5.592373	-8.88943
28.4573	0.2298	5.603341	-8.88543
28.6332	0.231	5.611882	-8.86105
28.809	0.2313	5.614358	-8.42117
28.9899	0.2327	5.625417	-8.39743
29.1429	0.2342	5.636522	-8.37635
29.1608	0.2357	5.647664	-8.37397
29.3367	0.2369	5.657018	-8.3508
29.5126	0.2371	5.658845	-8.32789
29.6884	0.2386	5.670062	-8.30526
29.8643	0.2401	5.805672	-8.27922
30.0402	0.2416	5.813953	-8.25715
30.2161	0.2429	5.821333	-8.23531
30.392	0.243	5.82217	-8.21371
30.5678	0.2445	5.830326	-8.19231
30.5714	0.2459	5.838422	-8.19187
30.7437	0.2474	5.846456	-8.17112
30.9196	0.2489	5.856753	-8.15013
31.0955	0.2503	5.864756	-8.12931
31.2714	0.2518	5.872697	-8.10867
31.2857	0.2533	5.880567	-8.10699
31.4472	0.2547	5.888371	-8.08819
31.6231	0.2548	5.888529	-8.06784
31.799	0.2562	5.896109	-8.04765
31.9749	0.2577	5.903775	-8.02758
32	0.2591	5.911373	-8.02472
32.1508	0.2606	5.918902	-8.00763
32.3266	0.2607	5.91951	-7.98758
32.5025	0.2621	5.926355	-7.96766

32.6784	0.2635	5.933738	-7.94782
32.7143	0.265	5.94105	-7.94378
32.8543	0.2665	5.948285	-7.92807
33.0302	0.2667	5.949309	-7.90837
33.206	0.2679	5.955445	-7.88873
33.3819	0.2694	5.954574	-7.86914
33.4286	0.2709	5.961547	-7.86396
33.5578	0.2723	5.968443	-7.8496
33.7337	0.2726	5.969841	-7.83008
33.9095	0.2738	5.975268	-7.81058
34.0854	0.2753	5.982019	-7.7911
34.1429	0.2767	5.988691	-7.78474
34.2613	0.2782	5.995286	-7.77162
34.4372	0.2786	5.997022	-7.75213
34.6131	0.2796	6.001802	-7.73264
34.7889	0.2811	6.000824	-7.71312
34.8571	0.2826	6.014606	-7.70555
34.9648	0.284	6.020891	-7.69357
35.1407	0.2845	6.022925	-7.674
35.3166	0.2855	6.027097	-7.65439
35.4925	0.287	6.033224	-7.63473
35.5714	0.2884	6.039274	-7.62588
35.6683	0.2899	6.045241	-7.61501
35.8442	0.2905	6.047533	-7.59524
36.0201	0.2914	6.051125	-7.33917
36.196	0.2928	6.056941	-7.3212
36.2857	0.2943	6.051125	-7.31202
36.3719	0.2958	6.068325	-7.30321
36.5477	0.2964	6.070836	-7.28521
36.7236	0.2972	6.073899	-7.26719

36.8995	0.2987	6.079393	-7.24915
37	0.3002	6.152802	-7.23882
37.0754	0.3016	6.155917	-7.23106
37.2513	0.3024	6.157464	-7.21296
37.4271	0.3031	6.158925	-7.1948
37.603	0.3046	6.161823	-7.1766
37.7143	0.306	6.164595	-7.16505
37.7789	0.3075	6.167587	-7.15834
38.1307	0.309	6.170804	-7.12166
38.3065	0.3104	6.173908	-7.10323
38.4286	0.3119	6.176896	-7.0904
38.4824	0.3134	6.179769	-7.08472
38.6583	0.3143	6.181529	-7.06615
38.8342	0.3148	6.182528	-7.0475
39.0101	0.3163	6.185187	-7.02877
39.1429	0.3178	6.187723	-7.01457
39.1859	0.3192	6.190149	-7.00996
39.3618	0.3202	6.191765	-6.99015
39.5377	0.3207	6.192462	-6.97015
39.7136	0.3222	6.194675	-6.95006
39.8571	0.3236	6.196774	-6.9336
39.8894	0.3251	6.198761	-6.92989
40.0653	0.3262	6.200194	-6.90961
40.2412	0.3265	6.200647	-6.88924
40.4171	0.328	6.202433	-6.86875
40.5714	0.3295	6.204107	-6.85069
40.593	0.3309	6.205711	-6.84816
40.7688	0.3321	6.206932	-6.82746
40.9447	0.3324	6.207237	-6.80664
41.1206	0.3339	6.208667	-6.78571

41.2857	0.3353	6.209951	-6.76595
41.2965	0.3368	6.211116	-6.76465
41.4724	0.3381	6.212063	-6.74347
41.6482	0.3383	6.212185	-6.72217
41.8241	0.3397	6.213159	-6.70074

Out of these 240 sample values 200 samples are used to train the network and 40 samples are used for testing purpose. The feed forward and RBF neural techniques are utilized to estimate the Directivity and SLL for the proposed design. The generalized neural model for estimation of two parameters is shown below in figure 5.6

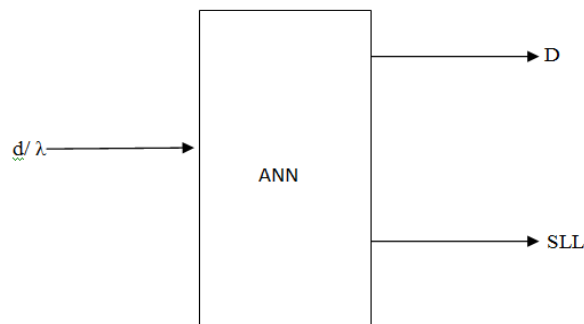

Figure 5.6 ANN Model

The neural analysis for both the techniques is presented in next section.

5.2.1 Feed forward NN with BP algorithm

Firstly Feed-forward neural network having different number of neurons in the hidden layer with Levenberg-Marquardt learning algorithm (LM) are created. The learning rate is set to .01. There are 240 data sample showing variation in the directivity with respect to normalized inter element spacing (d/λ), where $\lambda=120$ mm is the wavelength, obtained from CST simulation software.

To find the optimum Feed forward NN (In terms of hidden layer neurons), each network is trained twenty times and average MSE for each network is calculated for each network to find optimum network. Results for average MSE are shown in table 5.6. Plot for Average MSE with respect to different numbers of neurons in hidden layer is shown in figure 5.7.

Table 5.6 Average MSE with respect to different neurons in the hidden layer

n=5	n=10	n=15	n=20	n=25	n=30
0.005705472 74858611	0.001234758 02149844	0.000910913 245847630	0.001430263 41162120	0.000823014 520175637	0.003778150 99725275
0.005102941 43953470	0.000971844 545642697	0.001878321 25136270	0.001825005 20649171	0.000687293 605075130	0.000550803 352271593
0.007302819 60497441	0.004175062 11173676	0.001763616 43820887	0.000827917 529491140	0.001301256 88289235	0.009149979 53833223
0.005710423 15297370	0.000948852 285812779	0.001126715 44961293	0.004473504 69373480	0.007714943 27528594	0.004113591 70198651
0.004704981 83891608	0.001297653 98731521	0.001414569 94744265	0.001465893 66493102	0.001571564 50962233	0.000960084 021314369
0.008149868 77642368	0.002776336 25389171	0.001683151 06534320	0.001154859 45866995	0.000924248 888804040	0.001268227 10873818
0.005958265 54351645	0.001308904 73765881	0.001853482 75510552	0.001440417 22433317	0.001183836 42512441	0.002268103 51155765
0.008299735 51999129	0.001430450 78270391	0.001267500 06829912	0.000823306 624971432	0.001846759 41555158	0.004251975 47608094
0.005068451 73581662	0.001414514 26068726	0.001267505 65534021	0.000497539 752270741	0.001503744 55509715	0.000753383 088493269
0.005767251 11204253	0.001125138 66374362	0.001856625 90367130	0.001332454 57222762	0.001438843 72809060	0.000735872 337434747
0.005126116 92747752	0.001981458 18075178	0.001362989 40587696	0.000568557 248197069	0.001134614 98125554	0.001107607 59690608

0.007460329 03340340	0.002826066 59801395	0.000432165 198179861	0.002706557 06204487	0.001034088 66700070	0.000862104 832647828
0.005068992 60922453	0.002730774 72820411	0.000470207 605210169	0.001312444 55334535	0.001361177 59757266	0.000715809 404430245
0.004865361 22492616	0.003517153 29086648	0.001445480 10558840	0.001061426 14919988	0.002876219 16085296	0.001458657 53682983
0.004734631 98697231	0.002094304 75807900	0.001698545 85857694	0.002779670 98849569	0.007346004 55112829	0.001032875 92993414
0.005569592 14338253	0.001424781 81694868	0.000502693 899800526	0.001169481 36599903	0.001400129 09573011	0.012659611 8762042
0.005633770 87814527	0.000548184 991750264	0.001444006 26359980	0.000780180 353567872	0.002007568 51172732	0.001144845 29599724
0.004909741 37108626	0.001292570 71669413	0.001648568 94051939	0.001732086 41810824	0.001940655 65864026	0.002314220 52125374
0.005615001 21014447	0.004171886 38946056	0.002958073 73243815	0.004866176 63869172	0.001539995 79991611	0.001096102 22686762
Avg. MSE .0059	Avg. MSE .0020	Avg. MSE .0014	Avg. MSE .0018	Avg. MSE .0020	Avg. MSE .0026

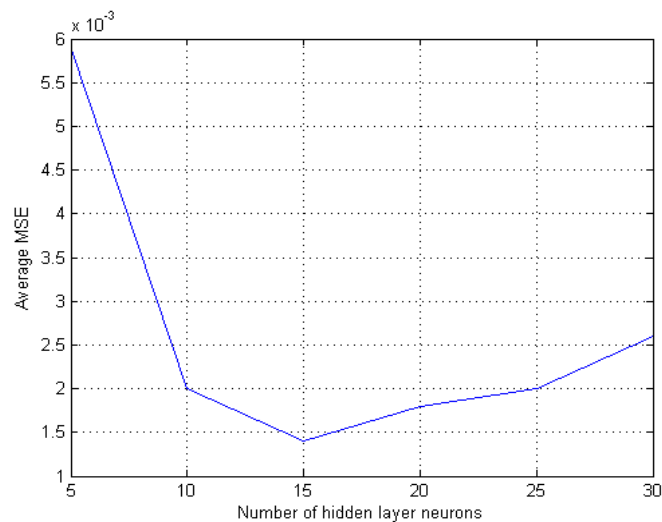

Figure 5.7 Average MSE with respect to number of neurons in the hidden layer.

Feed forward NN with 15 neurons in the hidden layer gives the best performance with minimum MSE of .014. So this network is used to optimize the array model. The performance goal which is MSE (mean square error) is found .0044233 at 9 epochs for this network. Performance plot is shown in Figure 5.8.

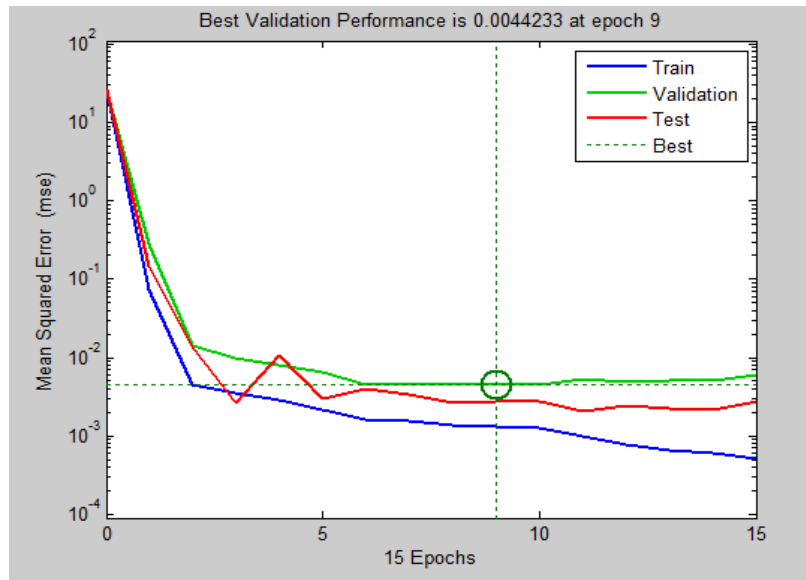

Figure 5.8 Feed-forward NN performance plot with 15 neurons in the hidden layer

5.2.2 Estimation using RBF ANN

Now the RBF NN is utilized for estimation of directivity. The same procedure as former is used to train the network i.e. out of 200 out of 240 data samples are used to train network and 40 are used to test. The performance goal is set to .001 and spread is set to .01. To find the optimal results different trials have been considered to find the size of hidden layer (number of neurons) and RBF NN with 85 neurons in hidden layer is found appropriate. Plot of MSE with respect to number of neurons in the hidden layer is shown in figure 5.9 MSE in tabular form is shown in table 5.7.

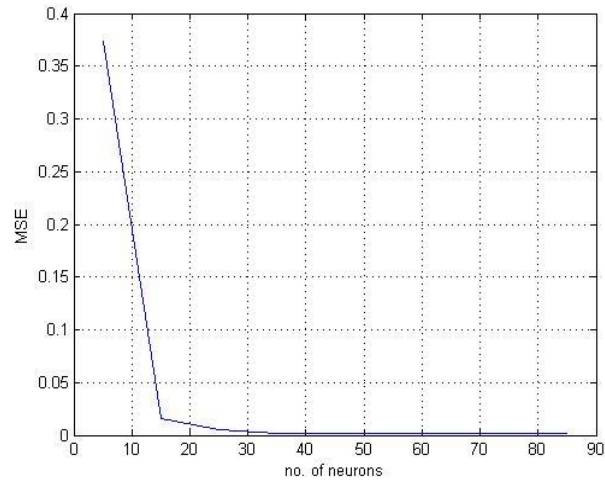

Figure 5.9 RBF MSE plot for different number of neurons in the hidden layer

Table 5.7 MSE with respect to different number of hidden layer neurons for RBF ANN

No. of neurons in hidden layer	MSE
0	0.779696
5	0.373799
10	0.14808
15	0.0163322
20	0.00598666
25	0.0048028
30	0.00248266
35	0.00195515
40	0.00182486
45	0.00169199
50	0.00161741
55	0.00153484
60	0.00141665
65	0.00133715
70	0.00133231
75	0.00129906

80	0.00128539
85	0.00127648

The performance plot for RBF NN is shown in figure 5.10.

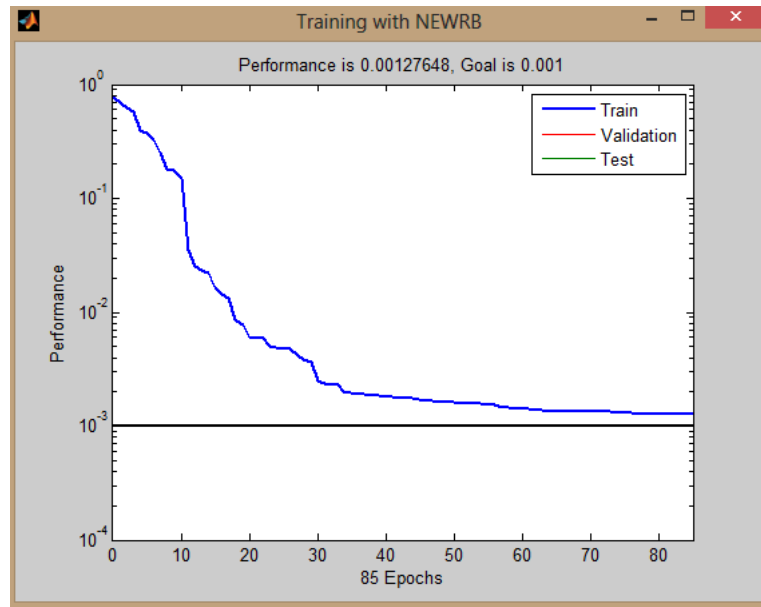

Figure 5.10 RBF NN performance plot

Similarly the analysis of results for the planar array is done using two types of ANN feed forward BP and RBF ANN to estimate the radiation parameters of the array. It is observed that Feedforward BP ANN gives better performance compare to RBF NN.

To find the optimum Feed forward NN (In terms of hidden layer neurons), Feed forward NN created with different number of neurons in the hidden layer. Now each network is trained twenty times and average MSE for each network is calculated for each network to find optimum network. Network with 15 neurons in hidden layer gives minimum average MSE of .0014.

Now the RBF NN is applied to estimate the directivity and SLL for the patch antenna. To find the optimum results for the parameter estimation different RBF NN are tested with respect to number of neurons in the hidden layer with the spread constant set to .01. It is found that RBF NN with the 85 hidden layer neurons gives the minimum MSE of .001276348 for the performance goal of .001.

Optimized results using both Feed forward and RBF ANN are shown in table 5.8. Simulated plots for directivity and SLL using both the networks with respect to original one are shown in figure 5.11 and 5.12 respectively.

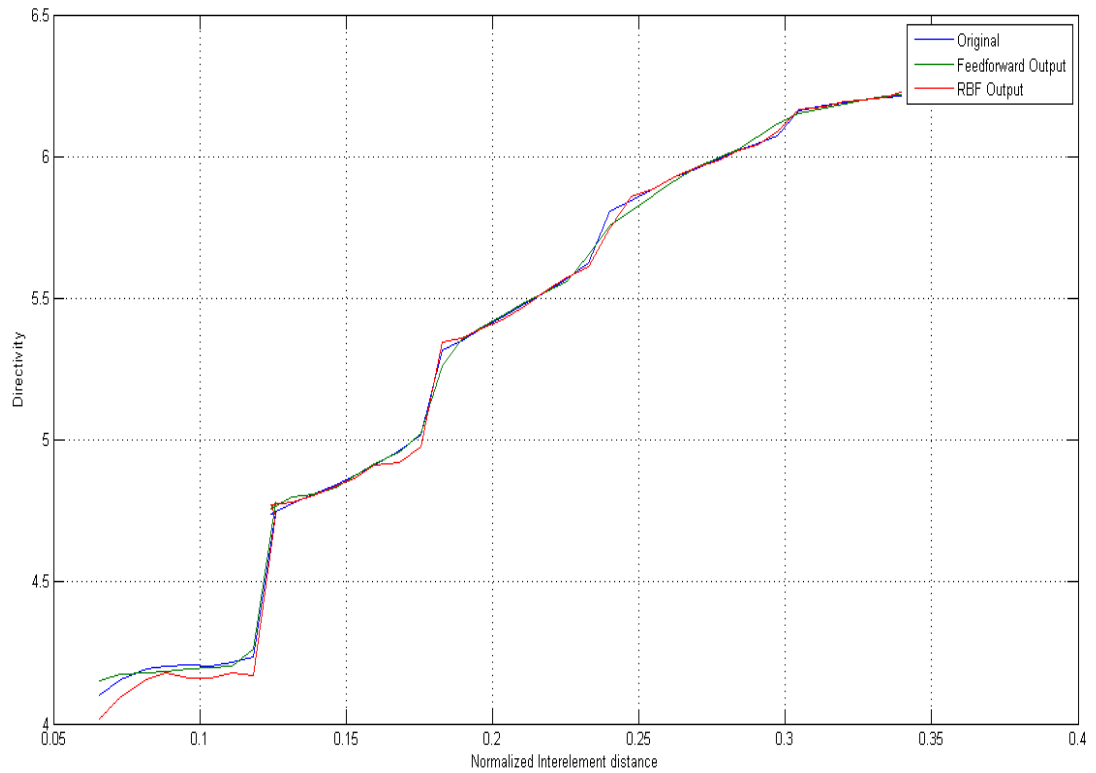

Figure 5.11 Estimated Directivity versus inter element distance by different Neural Techniques

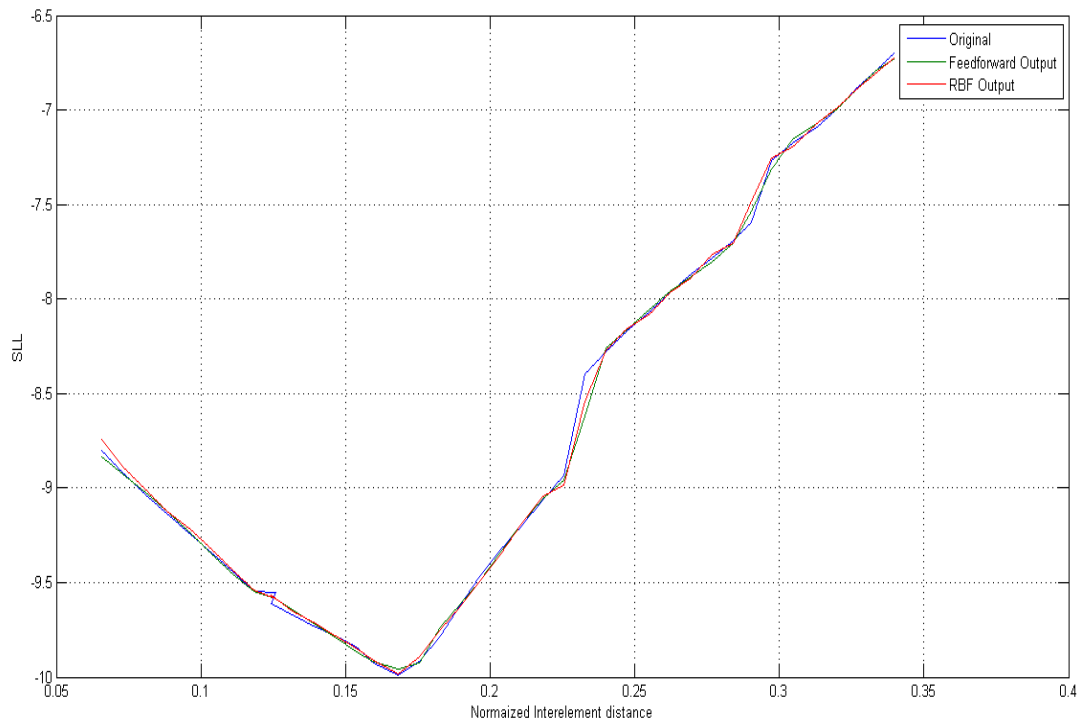

Figure 5.12 Estimated SLL versus inter element distance by different neural techniques

Table 5.8 Estimated results with Feed forward and RBF NN

d/λ	Directivity	SLL	$D_{\text{Feedforward}}$	$SLL_{\text{Feedforward}}$	D_{RBF}	SLL_{RBF}
0.0657	4.1020	-8.7987	4.1512	-8.8373	4.0144	-8.7436
0.0730	4.1550	-8.9170	4.1755	-8.9289	4.0945	-8.8848
0.0818	4.1916	-9.0467	4.1813	-9.0359	4.1566	-9.0252
0.0881	4.2034	-9.1335	4.1858	-9.1210	4.1776	-9.1235
0.0964	4.2062	-9.2440	4.1921	-9.2404	4.1611	-9.2197
0.1038	4.2038	-9.3428	4.1979	-9.3491	4.1605	-9.3258
0.1111	4.2155	-9.4440	4.2037	-9.4536	4.1805	-9.4336
0.1184	4.2352	-9.5460	4.2630	-9.5462	4.1716	-9.5400
0.1258	4.7451	-9.5537	4.7827	-9.5851	4.7329	-9.5823
0.1243	4.7373	-9.6117	4.7567	-9.5703	4.7714	-9.5638
0.1316	4.7751	-9.6718	4.7983	-9.6470	4.7795	-9.6538

0.1389	4.8078	-9.7292	4.8097	-9.7190	4.8027	-9.7112
0.1463	4.8438	-9.7795	4.8348	-9.7902	4.8359	-9.7827
0.1536	4.8793	-9.8425	4.8795	-9.8639	4.8688	-9.8449
0.1595	4.9133	-9.9222	4.9184	-9.9166	4.9120	-9.9117
0.1683	4.9633	-9.99264	4.9576	-9.9586	4.9212	-9.9822
0.1756	5.0211	-9.9206	5.0236	-9.9259	4.9773	-9.8929
0.1829	5.3175	-9.7797	5.2607	-9.7369	5.3446	-9.7474
0.1893	5.3515	-9.6260	5.3557	-9.6200	5.3607	-9.6306
0.1961	5.3918	-9.4758	5.3948	-9.5031	5.3933	-9.5001
0.2034	5.4352	-9.3322	5.4387	-9.3453	5.4248	-9.3552
0.2108	5.4787	-9.2033	5.4837	-9.1856	5.4704	-9.1884
0.2181	5.5208	-9.0614	5.5226	-9.0594	5.5296	-9.0433
0.2254	5.5706	-8.9347	5.5588	-8.9586	5.5726	-8.9827
0.2327	5.6254	-8.3974	5.6532	-8.6167	5.6108	-8.5414
0.2401	5.8057	-8.2792	5.7567	-8.2627	5.7465	-8.2720
0.2474	5.8465	-8.1711	5.8097	-8.1592	5.8580	-8.1579
0.2548	5.8885	-8.0678	5.8655	-8.0547	5.8861	-8.0851
0.2621	5.9264	-7.9677	5.9168	-7.9590	5.9276	-7.9667
0.2694	5.9546	-7.8691	5.9592	-7.8780	5.9598	-7.8892
0.2767	5.9887	-7.7847	5.9930	-7.8052	5.9849	-7.7640
0.2840	6.0209	-7.6936	6.0262	-7.7044	6.0239	-7.7031
0.2905	6.0475	-7.5952	6.0675	-7.5372	6.0415	-7.4804
0.2972	6.0739	-7.2672	6.1174	-7.3150	6.0874	-7.2540
0.3046	6.1618	-7.1766	6.1527	-7.1552	6.1687	-7.1971
0.3134	6.1798	-7.0847	6.1709	-7.0657	6.1757	-7.0628
0.3202	6.1918	-6.9901	6.1829	-6.9906	6.1945	-6.9892
0.3265	6.2006	-6.8892	6.1969	-6.8941	6.1984	-6.8947
0.3339	6.2087	-6.7857	6.2122	-6.7859	6.2083	-6.7968
0.3397	6.2132	-6.7007	6.2196	-6.7337	6.2276	-6.7230

5.3 Summary

Results for the both the objectives i.e. optimization of patch parameter using RBF ANN and utilization of ANN in directivity and SLL prediction are presented in this chapter. The generated results using ANN are found in a good agreement with the original EM simulated results in terms of minimum error and computational complexity. Results are shown in both tabular and simulated form. Results presented for the Array's radiation parameter are optimized more efficiently using Feed forward BP network in terms of directivity and SLL.

The Conclusion regarding the work done is presented in this chapter. The next section summarizes all of the work completed and the related results obtained. The section discuss about some technical contributions that the presented work have shown. In the last section the possibilities for the future work is discussed, whether any improvement in the presented work can be achieved or work can be expanded from the obtained results.

6.1 Conclusion

In the current scenario microstrip antenna has great significance due to various advantages discussed previously. The work presented in the thesis regarding the application of the artificial neural network (ANN) to optimize the patch parameters and characteristics. In work done is concluded mainly in two parts.

The resonant frequency of any antenna plays a key role in its operation. From the mathematical formula we know that resonant frequency is inversely proportional to the length of patch, which shows that antenna parameters are highly non linear to each other. To model these parameters conventional parameters used although produce good results but on the other hand inefficient in terms of time taken and computational complexity. In the first part ANN is utilized to estimate the Resonant frequency of microstrip patch antenna at different lengths. So to model this non linearity between the parameters a RBF ANN is utilized, which shows good performance in terms of time taken and not much complex in terms of computational complexity.

A total of 20 samples of parameters are calculated from the EM simulation using CST microwave studio, Out of which 12 samples are used to train the network and 8 samples are used to test the network. Results are estimated with different number neurons in the hidden layer. It is found that eight neurons in the hidden layer leads to best approximate the resonant frequency at different lengths of patch.

It is found that to model the patch using conventional EM simulation approach take too much time from the design perspective, whereas for an ANN after training process it is a task of

few seconds. So it can be concluded that the neural networks are very significant tool in the context of antenna designing.

The second part of conclusion is related to estimation of radiation characteristics of antenna. In order to enhance the beam forming (focusing) capacity of antenna array is utilized. Directivity is the key term related to antenna array. The conventional EM simulation methods are very complex and take too much time. Two types of ANN are utilized to estimate the directivity and SLL of a 2×2 microstrip planar array. Total of 240 samples were obtained using CST simulation software, out of which 200 samples are used to train the network and 40 samples are used for testing purpose. The comparison is made out between two different neural techniques. It is found that Feed forward backpropagation ANN gives better performance than that of RBF NN in context of modeling of directivity and SLL characteristics of the array.

So in the final conclusive remark it can be said that in today's scenario ANN are proved to be a significant tool in the field of Antenna designing and modeling, due to simple computational ability and less complexity. They are very efficient tool in context of minimum error and time consumption.

6.2 Future Scope

The work presented in the thesis is divided into the two main parts. The first part deals with the parameter optimization of microstrip patch. In this resonant frequency of a patch antenna estimated with respect to length of patch. Work can be further extended to model the antenna using the increase number of parameter i.e. resonant frequency with bandwidth of patch can be estimated with respect to the antenna dimension.

- The ANN used for measurement of antenna parameter is can be utilized for finding the position of slot in microstrip patch to achieve the desired frequency of operation from the antenna.
- In the work proposed ANN used is RBF ANN , work can be carried out on using different ANN models to design the antenna. Various optimization algorithms such as BFO (bacteria foraging optimization), PSO (particle swarm optimization), GA (genetic algorithm) can be used with ANN in order to get quick results with minimum error.

In the second work two types of neural networks are utilized to estimate the radiation characteristics of the antenna array directivity and SLL (side lobe level) and the comparison is made out between the results. The future possibilities for the work are as follows

- The work can be extended to increase the parameters of the array for estimation using ANN.
- A hybrid type of ANN using Feed forward and RBF ANN can be developed, which will have advantages of both the networks to achieve better estimation with minimum error.
- In the literature work is mainly carried out to estimate the directivity of the antenna array, so the radiation parameters can be increased.
- In this work a simple 2×2 microstrip planar array is designed, the work can be carried out to model different type of arrays such as circular, or the different number of elements can be placed along both the axis for planar array. No doubt the mathematical complexity will be increased but in this scenario use of ANN more relevant compared to present work.

References

- [1] R. Garg, P. I. Bhartia, I.J. Bhal and A. Ittipiboon, *Microstrip antenna design*, Hand book ,Artech house New York 2001.
- [2] C. A. Balanis, *Antenna Theory: Analysis and Design*, Second Edition, John Wiley & Sons Inc., NY, 1997.
- [3] I. Vilovic, N. Burum and M. Brailo, “Microstrip Antenna Design Using Neural Networks Optimized by PSO”, *IEEE Conference Publication*, no. 10.1109, pp. 1-4, 2013.
- [4] K. A. Kumar, R. Ashwath, D. S. Kumar and R. Malmathanraj, “Optimisation of Multislotted Rectangular Microstrip Patch Antenna using ANN and Bacteria Foraging Optimization”, *IEEE Conference Publication* , no. 10.1109, pp. 449-452, 2010.
- [5] B. M. Notaroš, *Electromagnetics*, Pearson Education Inc., NJ, 2011.
- [6] S. Lebbar, Z Guennoun, M. Drissi, F Riouch, “A Compact and Broadband Microstrip Antenna Design Using Geometrical-Methodology-Based Artificial Neural Network” *IEEE Antennas and Propagation Magazine*, vol. 48, No. 2, pp. 146-154, April 2006.
- [7] D. Langoni, “Gallium-arsenide MESFET small-signal modeling using backpropagation & RBF neural networks”, *thesis (M.S.)*, Florida State University, Dec. 2005.
- [8] A. Boualleg and N. Merabtine, “Analysis of radiation patterns of rectangular microstrip antennas with uniform substrate”, *Semiconductor Physics, Quantum Electronics & Optoelectronics*, vol. 8, no. 3, pp. 88-91, 2005.
- [9] A. A. Deshmukh and K. P. Ray, “Broadband Proximity-Fed Modified Rectangular Microstrip Antennas”, *IEEE Antennas & Propagation Magazine*, vol. 3, issue 5, pp. 41-56, October 2011.
- [10] D. K. Neog, S. S. Patnaik, D. C. Panda, S. Devi, B. Khuntia, and M. Dutta, “Design of a Wideband Microstrip Antenna And The Use of Artificial Neural Networks in Parameter Calculation”, *IEEE Antennas and Propagation Magazine*, vol. 47, no. 3, pp. 60-65, June 2005.
- [11] R. Ghayoula, A. Gharsallah, N. Fadlallah, and M. Rammal, “Artificial Neural

- Networks ANN Approach for the Synthesis of Patch Antennas”, *IEEE Radar Conference*, pp. 85-90, 2007.
- [12] Mohammad Naser Mogadhassi, Pouya Derakhshan Barjoei, “A Heuristic Artificial Neural Network Design of Resonant Frequency of Rectangular Microstrip/Patch Antennas” *International Conference on Information and Communication technologies from Theory to Application (ICTTA)*, pp 1-5, April 2005.
- [13] Balwinder Singh Dhaliwal, Shyam S. Pattnaik, “Performance Evaluation of Artificial Neural Networks in Microstrip Fractal Antenna Parameter Estimation”, *IEEE International Conference On Communication System*, pp. 135-139, November 2012.
- [14] M.Aneesh, J. Ansari, A. Singh, Kamakshi and S. Verma, “RBF Neural Network Modeling of Rectangular Microstrip Patch Antenna”, *IEEE Conference Publication*, pp. 241-244, 2012.
- [15] I. J. Bahl and D. K. Trivedi, “A Designer’s Guide to Microstrip Line”, *Microwaves*, pp. 174-182, May 1977.
- [16] R. Malmathanraj, S Thamarai Selvi, “ Artificial Neural Network application in Parameter Optimization of Rectangular Microstrip Patch Antenna”, *Ubiquitous Computing and Communication Journal*, vol 3, no 2, pp. 94-108,
- [17] Teresa H. Donnell, Hugh L. Southhall, Jeffery A. Simmers, Thomas J. Klemas, “Neural Network Antenna Processing for Detection and Direction Finding”, *IEEE International Radar Conference*, pp. 213-218, 1995.
- [18] Giovanni Anguilli Mario Versaci, “Resonant Frequency Evaluation of Microstrip Antennas Using a Neural-Fuzzy Approach”, *IEEE Transactions On Magnetics*, vol. 39, pp. 1333-1336, May 2003.
- [19] J. Laxmi Narayana, K. SriRamaKrishna, L. Pratap Reddy, “Design of Microstrip Antennas Using Artificial Neural Networks”, *International Conference on Computational Intelligence and Multimedia Application*, pp. 332-334, December 2007.
- [20] D. Vakula , N. V. S. N. Sarma, “Neural Network Approach To Diagnose Faults Of Antenna Array”, *The second European Conference on Antennas and Propagation*, pp. 1-5, November 2007.
- [21] Samik Chakraborty, Sabyasachi Mandal, Bhaskar Gupta, “Neural Network Modeling

- for the Fast Estimation of Superstrate Loading Effect on Rectangular Microstrip Patch Antennas”, *IEEE Applied Electromagnets Conference*, pp. 1-3, December 2007.
- [22] Vandana Vikas Thakare, Pramod Singhal, Kamy Das, “Calculation of Microstrip Antenna Bandwidth using Artificial Neural Network”, *IEEE International Rf And Microwave Conference Proceeding*, pp. 404-406, December 2008.
- [23] Marija Milizic’, Zoran Stanovic’, Bratislav Milovanovic’, “Efficient Model of Slotted Patch Antenna based on Neural Networks”, *International Conference on Telecommunication in Modern Satellite, Cable and Broadcasting Services*, pp. 384-387, October 2009.
- [24] K. Kumar, N. Gunasekran, “Bandwidth Enhancement of a Notch Square Shaped Microstrip Patch Antenna using Neural Network Approach”, *International Conference on Emerging Trends in Electrical and Computer Technology*, pp. 797-799, March 2011.
- [25] T. Bose, N. Gupta, “Design of an aperture-coupled microstrip antenna using a hybrid neural network”, *International Conference on Microwaves, Antennas and Propagation*, pp. 470-474, March 2012.
- [26] Bablu Kumar Singh, “Design of Rectangular Microstrip Patch Antenna based on Artificial Neural Network Algorithm”, *International Conference on Signal Processing and Integrated networks*, pp. 6-9, 2015.
- [27] A. L. Tatzov, “Neural Network Methods For Radar Processing”, *International Conference on Neural Information Processing*, pp. 1718-1722, November 2002.
- [28] Pedram Yazdanbakhsh, Klaus Solbach, “Optimization of Monopole Four-Square Array Antenna Using a Decoupling Network and a Neural Network to Model Ground Plane Effects”, *European Conference on Antennas and Propagation*, pp. 3014-3018, March 2009.
- [29] Heriberto Jose Delgado, Michael H. Thursby, Fredric M. Ham, “A Novel Neural Network for the Sythesis of Antennas and Microwave Devices”, *IEEE Transaction On Neural Networks*, Vol. 16, no. 6, pp. 1590-1600, November 2005.
- [30] Addaci Rafik, Staraj Robert, “Artificial Neural Network Modeling Technique for fast analysis and design of multi antenna system”, *European conference on Antennas and Propagation*, pp 2034-2037, April 2013.

- [31] C. S. DeLuccia, D. H. Werner, "Nature-Based Design of Aperiodic Linear Arrays with Broadband Elements Using a Combination of Rapid Neural-Network Estimation Techniques and Genetic Algorithms", *IEEE Antenna and Propagation Magazine*, Vol. 49, pp. 13-23, Oct 2007.
- [32] Zaharias D. Zaharis, Christos Skeberis, Thomas D. Xenos, Pavlos I. Lazaridis, John Cosmas, "Design of a Novel Antenna Array Beamformer Using Neural Networks Trained by Modified Adaptive Dispersion Invasive Weed Optimization Based Data", *IEEE Transaction On Broadcasting*, Vol. 59, No. 3, pp. 455-460, September 2013.
- [33] G. Pelosi, A. Pinto, C. Riminesi, S. Selleri, M. Tatini, "Inter-element coupling in large arrays by an ANN approach", *IEEE Antennas and Propagation Society International Symposium*, pp. 523-526, 2004.
- [34] N. somasiri, X. Chen and A. Rezazadeh, "Neural network modeller for design optimisation of multilayer patch antennas", *IEE*, vol. 151, no. 6, pp. 514-518, 2004.
- [35] S.K.Jain, A. Pataniak and S.N.Sinha, "Stacked Patch Antenna Design using ANN based BFO", *IEEE Conference Publication*, Kolkata, 2011.
- [36] M.Wnuk, L. Nowosielski and M. Bugaj, "The Utilization of Neural Networks to Radiation Pattern of Microstrip Antenna Formation", *IEEE*, no. 10.1109, pp. 1-5, 2013.
- [37] Anuradha, A. Patnaik and N. S. S, "Design Of Custom Made Fractal Multiband Antenna Using ANN-PSO", *IEEE Journals And Magazines*, vol. 53, no. 4, pp. 94-101, 2011.
- [38] J. Shang, N. Zhang and X. Li, "An Effective Method For Rfid Tag Antenna Optimization Baed On Artificial Neural Network", *IEEE Conferencre Publication*, no. 10.1109, pp. 383-386, 2010.
- [39] K. T. and D. Asok, "Design of Circular/Triangular Patch Microstrip Antenna using Single Neural Network", *IEEE Conference Publication*, no. 10.119, pp.1-4, 2011.
- [40] I. vilovic and N. Burun, "Design anf Feed position estimation for Circular Microstrip Antenna Based On Neural Network Model", *IEEE Conference Publications*, pp. 3614-3617, 2012.

List of Publications

- [1]. Yogesh Maharishi, Amanpreet Kaur, “A Novel Artificial Neural Network based Directivity Estimation Technique for Planar Antenna Arrays”, Microwave and Optical technology letters. (Communicated)