

**Performance Investigation of a New Compressor Model
having Green Refrigerant (R290) in a Vapour Compression
Cycle**

A Dissertation submitted in fulfillment of the requirements for the Degree
of

MASTER OF ENGINEERING

in

POWER SYSTEMS

Submitted by

Prabhjot Singh Saini
Registration No.: 802042019

Under the Guidance of

Dr. Smarajit Ghosh

Professor, EIED

Mr. Prashant Rana

S.E.-II, COM-Development LG Electronics



THAPAR INSTITUTE
OF ENGINEERING & TECHNOLOGY
(Deemed to be University)

2022

Electrical and Instrumentation Engineering Department

Thapar Institute of Engineering & Technology, Patiala

(Declared as Deemed-to-be-University u/s 3 of the UGC Act., 1956)

Post Bag No. 32, Patiala – 147004

Punjab (India)

DECLARATION

I hereby certify that the work which is presented in dissertation entitled, “**Performance Investigation of a New Compressor Model having Green Refrigerant (R290) in a Vapour Compression Cycle**” in partial fulfillment of the requirements for the award of the degree of **Master of Engineering in Power Systems** submitted to Electrical & Instrumentation Engineering Department of Thapar Institute of Engineering & Technology (Deemed to be University) is as authentic record of my own work carried under the supervision of **Dr. Smarajit Ghosh (Professor, EIED)**. It refers others researcher’s work which are duly listed in the reference section. The matter contained in this dissertation has not been submitted, neither in part nor in full to any other degree to any other university or institute except as reported in text and references.

Place: Patiala

Date: 28-07-2022

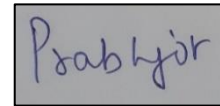

Prabhjot Singh Saini

Roll No. 802042019

Power Systems (M.E.)

It is certified that the above statement made by the student is correct to the best of my knowledge and belief.

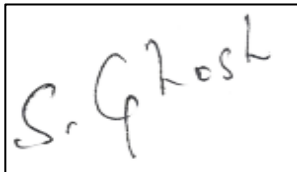

Dr. Smarajit Ghosh

Professor

EIED, TIET

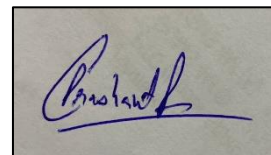

Mr. Prashant Rana

S.E.-II (R&D)

Compressor and Motor Development

LG Electronics, India

ACKNOWLEDGEMENT

I would like to express my special thanks and a sense of gratefulness to my honorable guide, **Dr. Smarajit Ghosh (Professor, EIED , TIET, Patiala)** for their guidance and support throughout my thesis work. I shall always remain grateful for his excellent guidance, valuable discussion, encouragement and his insights have strengthened this study significantly. Further, I would like to thank my industrial supervisor **Mr. Prashant Rana (Senior Engg. II , R&D Compressor & Motor development, LG. Electronics, Greater Noida)** for providing me the technical support, facilities, and skills that really helped me during the work.

My sincere thanks to team of compressor and motor development from LG electronics India Ltd., specially, **Mr. Prateek Sharma (Asst. Manager), Mr. Rishav Sharma (Sr. Engineer II), Mr. Mukul Singh (Sr. Engineer I)** for their technical advice and supporting me in the industrial labs throughout the experimentation work.

Finally, I would like to express my sincerest sense of gratitude to my family for their moral support and best wishes.

Prabhjot Singh Saini

802042019

EIED

Thapar Institute of Engineering and Technology

TABLE OF CONTENTS

DECLARATION	i
ACKNOWLEDGEMENT	ii
LIST OF FIGURES	vi
LIST OF TABLES	viii
NOMENCLATURE.....	ix
ABSTRACT.....	xi
CHAPTER 1: INTRODUCTION	1
1.1 VAPOUR COMPRESSION REFRIGERATION SYSTEM.....	1
1.1.1 CONDENSER.....	2
1.1.2 EXPANSION VALVE.....	2
1.1.3 COMPRESSOR	3
1.1.4 EVAPORATOR.....	3
1.2 REFRIGERANTS	4
1.2.1 PRIMARY AND SECONDARY REFRIGERANTS	4
1.2.2 NOMENCLATURE OF REFRIGERANTS	4
1.2.3 PROPERTIES OF IDEAL REFRIGERANTS	6
1.2.4 CATEGORIES OF REFRIGERANTS	10
1.3 OZONE DEPLETION AND GLOBAL WARMING POTENTIAL	11
1.4 COMPRESSORS	13
1.4.1 RECIPROCATING COMPRESSORS.....	13
1.4.2 ROTARY LOBE COMPRESSORS.....	14
1.4.3 LIQUID RING ROTARY COMPRESSORS.....	15
1.4.4 HELICAL LOBE COMPRESSORS	16
1.4.5 CENTRIFUGAL COMPRESSORS.....	16
1.4.6 AXIAL COMPRESSORS.....	17

1.5	WORK OUTLINE.....	18
1.6	ORGANIZATION OF THE THESIS.....	18
CHAPTER 2: LITERATURE REVIEW		19
2.1	INTRODUCTION	19
2.2	NUMERICAL STUDY	19
2.2.1	NATIONAL STATUS OF LITERATURE.....	19
2.2.2	INTERNATIONAL STATUS OF LITERATURE	20
2.3	EXPERIMENTAL STUDY.....	22
2.4	GAPS IN LITERATURE REVIEW.....	26
2.5	THESIS OBJECTIVES	27
CHAPTER 3: EXPERIMENTAL AND NUMERICAL METHODOLOGY		28
3.1	INTRODUCTION.....	28
3.2	THEORETICAL STUDY.....	28
3.2.1	STUDY OF REFRIGERANTS	28
3.2.2	ASHRAE CONDITIONS.....	29
3.2.3	NUMERICAL ANALYSIS	30
3.3	EXPERIMENTAL STUDY.....	32
3.3.1	HERMETIC RECIPROCATING COMPRESSOR	32
3.3.2	EXPERIMENTAL CHAMBER:.....	39
CHAPTER 4: RESULTS AND DISCUSSION		44
4.1	THEORETICAL ANALYSIS	44
4.2	EXPERIMENTAL ANALYSIS	49
CHAPTER 5: CONCLUSION AND FUTURE SCOPE.....		56
5.1	SUMMARY	56
5.2	CONCLUSION	56
5.3	FUTURE SCOPE.....	57

REFERENCES58

LIST OF FIGURES

Fig. 1: Schematic diagram of vapour compression refrigeration system [3]	2
Fig. 2: Non-superheating/subcooling.....	3
Fig. 3: Superheating/subcooling.....	3
Fig. 4: Properties of ideal refrigerants.....	6
Fig. 5: Classification of compressors	13
Fig. 6: Schematic diagram of reciprocating compressors [8].....	14
Fig. 7: Schematic diagram of rotary lobe compressor [9].....	15
Fig. 8: Schematic diagram of liquid ring rotary compressors [9]	16
Fig. 9: Schematic diagram of helical lobe compressors [10]	16
Fig. 10: Schematic diagram of centrifugal compressors [10]	17
Fig. 11: Schematic diagram of axial compressor [9]	17
Fig. 12: Pressure v/s enthalpy graph for VCRS with subcooling and superheating.....	30
Fig. 13: Assembly of hermetic compressor (top view) [LG. electronics India].....	32
Fig. 14: Assembly of hermetic compressor (side view) [LG. electronics India]	33
Fig. 15: (a) Induction motor	38
Fig. 16: Hermetic reciprocating compressor [LG. Electronics, India].....	38
Fig. 17: Schematic diagram of secondary fluid calorimeter [38].....	40
Fig. 18: Experimental Setup [LG. Electronics, India]	41
Fig. 19: Secondary fluid calorimeter testing chamber [LG electronics India].....	42
Fig. 20: Vacuum process of Compressor [LG. Electronics, India].....	43
Fig. 21: Variation of saturated pressure with saturated temperature	44
Fig. 22: Variation of saturated liquid density with temperature.....	45
Fig. 23: Variation of saturated vapour density with temperature	45
Fig. 24: Variation of latent heat with temperature.....	46
Fig. 25: Mass flow rate of refrigerants	47
Fig. 26: Cooling power of refrigerants.....	48
Fig. 27: Compressor power of Refrigerants	48
Fig. 28: COP of Refrigerants	49

Fig. 29: Input power of Compressor's samples	52
Fig. 30: Suction pressures of Compressor's samples.....	52
Fig. 31: Discharge pressures of Compressor's samples.....	53
Fig. 32: Discharge temperatures of Compressor's samples.....	53
Fig. 33: Cooling Power of Compressor's samples	54
Fig. 34: Mass Flow Rate of refrigerants with Compressor's samples	54
Fig. 35: COP of refrigeration system	55

LIST OF TABLES

Table 1: Properties of refrigerants used in domestic refrigerators [14]	10
Table 2: ODP and GDP of some common refrigerants [7].....	12
Table 3: Property comparison of R134a & R290 [5], [6].....	29
Table 4: ASHRAE testing standards [35].....	30
Table 5: Components of hermetic compressor	33
Table 6: Specifications of testing compressor	39
Table 7: Theoretical comparison of performance parameters between R134a and R290.....	47
Table 8: Experimental results with R134a	50
Table 9: Experimental results with R290	51

NOMENCLATURE

m	Number of carbon atoms
n	Number of hydrogen atoms
p	Number of chlorine atoms
q	Number of fluorine atoms
Q	Heat transfer rate (W)
m_r	Mass flow rate of refrigerants (kg/s)
V	Volumetric displacements by piston (m^3)
ρ	Density of vapour refrigerant (kg/m^3)
W _c	Power input by compressor (W)
h_1'	Specific enthalpy of refrigerant at outlet of the evaporator (J/kg)
h_2	Specific enthalpy of refrigerant at outlet of the compressor (J/kg)
h_3'	Specific enthalpy of refrigerant at outlet of the condenser (J/kg)
h_4	Specific enthalpy of refrigerant at inlet of the evaporator (J/kg)
P	Pressure (N/m^2)

SUBSCRIPTS

r	refrigerant
evap	evaporator
cond	condenser
c	compressor
dis	discharge
suc	suction

ABBREVATIONS

ODP	Ozone depletion potential
GWP	Global warming potential
IP	Input power
CC	Cooling capacity
CFC	ChloroFluoroCarbons
HCFC	HydroChloroFluoroCarbons
HFC	HydroFluoroCarbons
FC	FluoroCarbons
HC	HydroCarbons
COP	Coefficient of performance
UV	Ultraviolet
LBP	Low back pressure
MBP	Medium back pressure
HBP	High back pressure
ASHRAE	American society of heating, refrigerating and air-conditioning engineers
VCRS	Vapour compression refrigeration system
RSIR	Resistor start induction run
PTC	Positive thermal coefficient
PAG	Polyalkylene Glycol
HVAC	Heating ventilation and cooling
GEHP	Gas engine heat pump
AC	Air Conditioning

ABSTRACT

Refrigeration and air conditioning now a day is becoming necessary for providing individual comfort to humans and also to store food so that its freshness stays longer. Refrigeration has many applications including household refrigeration, air conditioning, cryogenics, industrial freezers etc. Talking about refrigeration system two important components of the refrigeration system that is compressor and refrigerant have to be considered as primary subject to study for overall performance of the system. An ecofriendly and safe refrigerant which have zero ODP and zero GWP is required in the refrigeration system. This study is more focused about induction models of Hermetic compressors used in domestic refrigerator. Induction models of compressors used in domestic refrigerators works with a HFC refrigerant that is Tetrafluoroethane (R134a), which have zero ODP but have significant GWP. From previous studies it is found that HC refrigerants are most ecofriendly and suitable working fluid in refrigeration system. They have zero ODP and negligible GWP and also called as “Green refrigerants”. So in this study, propane (R290) which is suitable HCs refrigerant or green refrigerant is used as alternative for R134a in induction model of hermetic compressor and performance of this green refrigerant in secondary fluid calorimeter (experimental setup used for performance analysis of compressors) with new induction model of compressor is compared with primarily used refrigerant R134a.

Numerical and Experimental analysis has been done with two respective refrigerants. The key parameters for performance comparison are mass flow rate of refrigerant in system, input power (IP) by compressor, discharge and suction pressure in compressor, cooling power or cooling capacity (CC) and coefficient of performance (COP).

It was observed from experimental study that with R290, IP of compressor is almost 27-29% high and CC of system is 40-41% more in compare to R134a. While COP of system with R290 is 8-10% higher than R134a. Apart from this, it can be noticed from numerical and experimental study that R290 works on higher pressure ranges as comparative to R134a. So, in this end of the study it can be concluded that green refrigerant (R290) is suitable in terms of performance in induction models of hermetic compressors which are used in domestic refrigerators.

Keywords: Domestic refrigerator, refrigerants, ODP, GWP, hermetic compressor (Induction model), key parameters, performance comparison.

CHAPTER 1

INTRODUCTION

Around the world, the creation of cold lodging is viewed as a significant energy challenge of this new century. However right now, the creation of cold arrangements is basically founded on various refrigeration systems. With headway in innovation, cyclic refrigeration (Vapor-compression refrigeration system) assumes a vital part in domestic, business, food preparing, and electronic cooling refrigeration system. It is then important to make the selection of refrigerants in such a way that they cause less hazard to the climate, especially by diminishing ozone depleting substance discharges and reduction of greenhouse gases by preparing refrigerants ecofriendly. On the solution of that HFCs like R134a, R410A, R152a are introduced which have zero ozone depletion potential (ODP) but they do have significant Global Warming Potential (GWP) and most of them have lower performance as compare to other potential refrigerants. So now studies on proper substitutes are going on and role of HCs like butane (R600), Iso-butane (R600a), dimethyl ether (R-E170), pentane (R-601), Iso-pentane (R-601a), propane (290) and various blends of HCs are coming into the picture which possess very low GWP as K. Harby [1] and Antunes et al. [2] has given a review on the various HCs , HFCs and their blends in different systems as alternates in their studies. But due to variable thermo physical properties of the HCs and HFCs such as flammability, latent heat of vaporization, density, saturation temperature and saturation pressure it is difficult to comment on the optimum performance of these refrigerants in a particular refrigeration system. In this thesis work, numerical and experimental work on the Hermetic reciprocating compressor, used in domestic refrigeration system has been done with two refrigerants (R134a, R 290) and performance of refrigeration system is investigated to predict the suitable ecofriendly refrigerant for domestic refrigerators.

1.1 VAPOUR COMPRESSION REFRIGERATION SYSTEM

A VCRS is a modification of air refrigeration system in which a working substance, termed as refrigerant is used and is compressed by the use of a compressor as the low pressure and temperature vapour refrigerant from the evaporator outlet is compressed into high pressure and temperature vapour refrigerant, so it is named as vapour compression refrigeration cycle. In the VCRS, modification on the basis of cycle in order to improve the system performance and energy consumption is mostly done in condenser and evaporator sections of the refrigerator. Fig. 1 shows the schematic diagram for VCRS consisting of essential components such as compressor,

condenser, expansion device and evaporator. The performance of a domestic refrigerator is totally dependent on working of these components and modifications needs to be done for the variation in the efficiency of the system. A simple vapour compression refrigeration system basically consists of four essential parts which are explained as below:

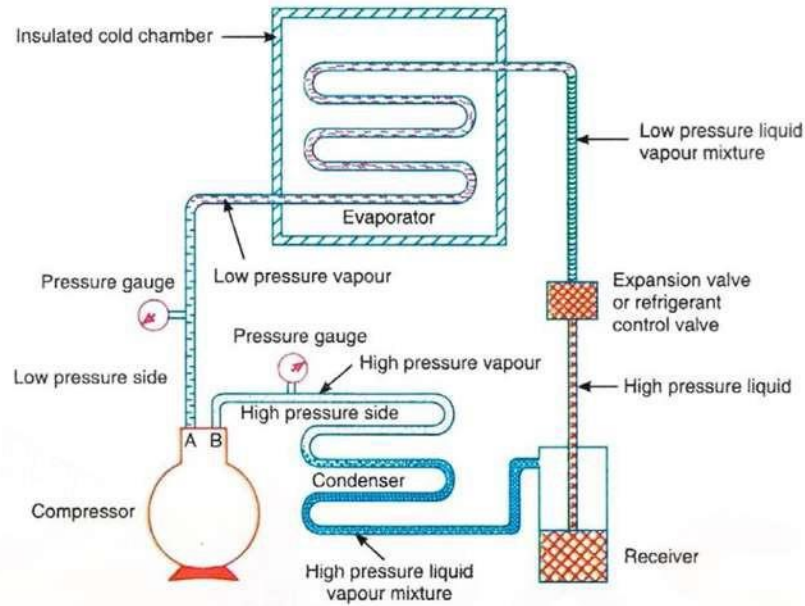

Fig. 1: Schematic diagram of vapour compression refrigeration system [3]

1.1.1 CONDENSER

Condenser component in the VCRS is used for condensation of high temperature and pressure vapour refrigerant from the outlet of the compressor and convert it into liquid at constant temperature and pressure. During condensation process, the refrigerant gives its latent heat to surroundings. The condensation process includes superheating zone, condensation zone and sub-cooling zone which are explained in the condensers section.

1.1.2 EXPANSION VALVE

Expansion valve also termed as throttle valve or refrigerant control valve allows refrigerant to expand which reduces the temperature and pressure of the liquid refrigerant. During the expansion process, there is no addition of heat or removal of heat.

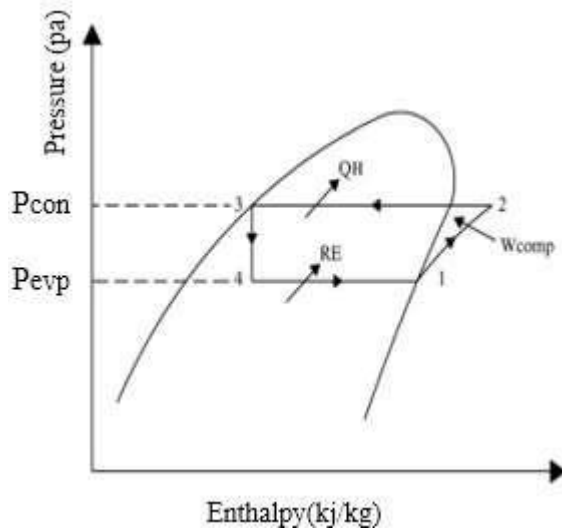

Fig. 2: Non-superheating/subcooling

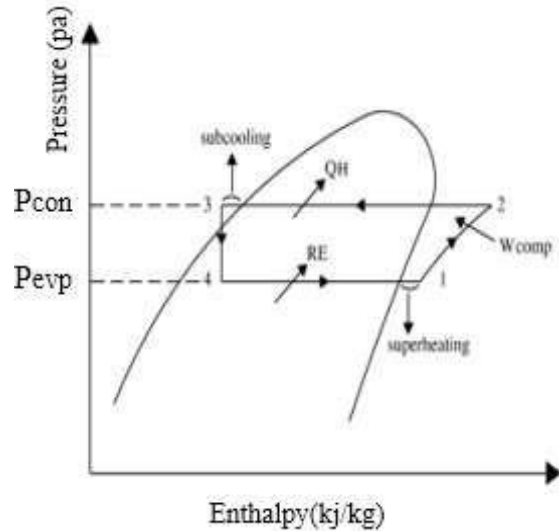

Fig. 3: Superheating/subcooling

1.1.3 COMPRESSOR

In vapour compression refrigeration system, the low pressure and temperature vapour refrigerant which is drawn from the evaporator into the compressor through the inlet valve or suction valve point 1 is compressed into high pressure and temperature vapour refrigerant which is then discharged through the delivery valve point 2 into condenser. The work done during the compression process is given by:

$W = \text{enthalpy of refrigerant leaves the evaporator} - \text{enthalpy of refrigerant enters in the condenser}$

1.1.4 EVAPORATOR

An evaporator consists of coils of pipe where the low pressure and temperature liquid-vapour refrigerant is evaporated and transformed into low pressure and temperature vapour refrigerant. During evaporation process, the liquid-vapour refrigerant absorbs its latent heat of vaporization from the space which has to be cooled. This completes the refrigeration cycle. The refrigerating effect or cooling capacity (CC) by liquid-vapour refrigerant is given by:

$CC = \text{enthalpy of refrigerant enter in the evaporator} - \text{enthalpy of refrigerant leaves the evaporator}$

Therefore, Coefficient of Performance (COP) is defined as the ratio of cooling capacity to the work input by compressor.

1.2 REFRIGERANTS

Refrigerant is the liquid utilized for heat move in a refrigerating system that assimilates heat during evaporation from the location of low temperature and pressure, and deliveries heat during buildup at a location of higher temperature and pressure. As of now, we have an enormous number of refrigerants accessible to us contingent upon the prerequisites of the specific refrigerating system. Therefore a detailed investigation of these refrigerants is required. In general refrigerants are categorized into two terms:

1. Primary Refrigerants.
2. Secondary Refrigerants.

1.2.1 PRIMARY AND SECONDARY REFRIGERANTS

The primary refrigerants are those that pass through the cycles of evaporation, compression, condensation and expansion. Alkali, R12, R22, carbon dioxide go under this class of refrigerants. Then again, the medium which doesn't go through the cyclic measures in a refrigeration system and is just utilized as a mode for heat move are mentioned to as secondary refrigerants. Water, brine water arrangements of sodium chloride and calcium chloride go under this class.

1.2.2 NOMENCLATURE OF REFRIGERANTS

The American Society of Refrigerating Engineers (ASRE) has adopted certain formulations for use in naming various kinds of refrigerants. These naming conventions vary as per the sort of refrigerant. Every refrigerant sort is indicated by an alternate arrangement. In this way, we have separate arrangement for halogenated refrigerants and different other kinds. These conventions are currently acknowledged worldwide and help to name the huge assortment of refrigerants accessible industrially these days. [4]

The conventions for Refrigerants is mentioned as:

Chemical convention: $C_m H_n F_p Cl_q$

Where

C: carbon atoms	m: number of carbon atoms
H: hydrogen atoms	n: number of hydrogen atoms
Cl: chlorine atoms	p: number of chlorine atoms
F: fluorine atoms	q: number of fluorine atoms

1.2.2.1 SATURATED HYDROCARBONS

Condition: $n+p+q=2m+2$

Nomenclature: R (m-1) (n+1) p

For example: CCl_2F_2 $m = 1, n = 0, p = 2, q = 2$

$$n+p+q = 2m+2$$

$$0+2+2 = 2(1) + 2$$

$$4 = 4 \quad [\text{Hence condition for Saturated Hydrocarbons satisfied}]$$

Therefore, R (m-1) (n+1) p = R012 or R12

1.2.2.2 UNSATURATED HYDROCARBONS

Condition: $n+p+q=2m$

Nomenclature: R1 (m-1) (n+1) p

For example: C_2H_4 $m = 2, n = 4, p = 0, q = 0$

$$n+p+q = 2m$$

$$4+0+0 = 2(2)$$

$$4 = 4 \quad [\text{Hence condition for Unsaturated Hydrocarbons satisfied}]$$

Therefore, R1 (m-1) (n+1) p = R1150

1.2.2.3 ORGANIC COMPOUNDS

Nomenclature: R (700+molecular weight)

For example: CO_2

Molecular weight of Carbon (C) = 12

Molecular weight of Oxygen (O_2) = $2 \times 16 = 32$

Molecular weight of Carbon dioxide (CO_2) = $12+32 = 44$

Therefore, R (700+molecular weight) = R744

Similarly, NH_3

Molecular weight of Ammonia (NH_3) = $14+3(1) = 17$

Therefore, R (700+molecular weight) = R717

1.2.3 PROPERTIES OF IDEAL REFRIGERANTS

The tremendous number of refrigerants accessible in the market today permits us to pick a refrigerant depend on the working circumstances of the refrigeration system. Accordingly, there is no refrigerant that can be favorably utilized under all working conditions and in a wide range of refrigeration systems. Although, we can express certain attractive properties that a refrigerant should gang. These properties can be isolated into good thermodynamic, compound and physical properties.

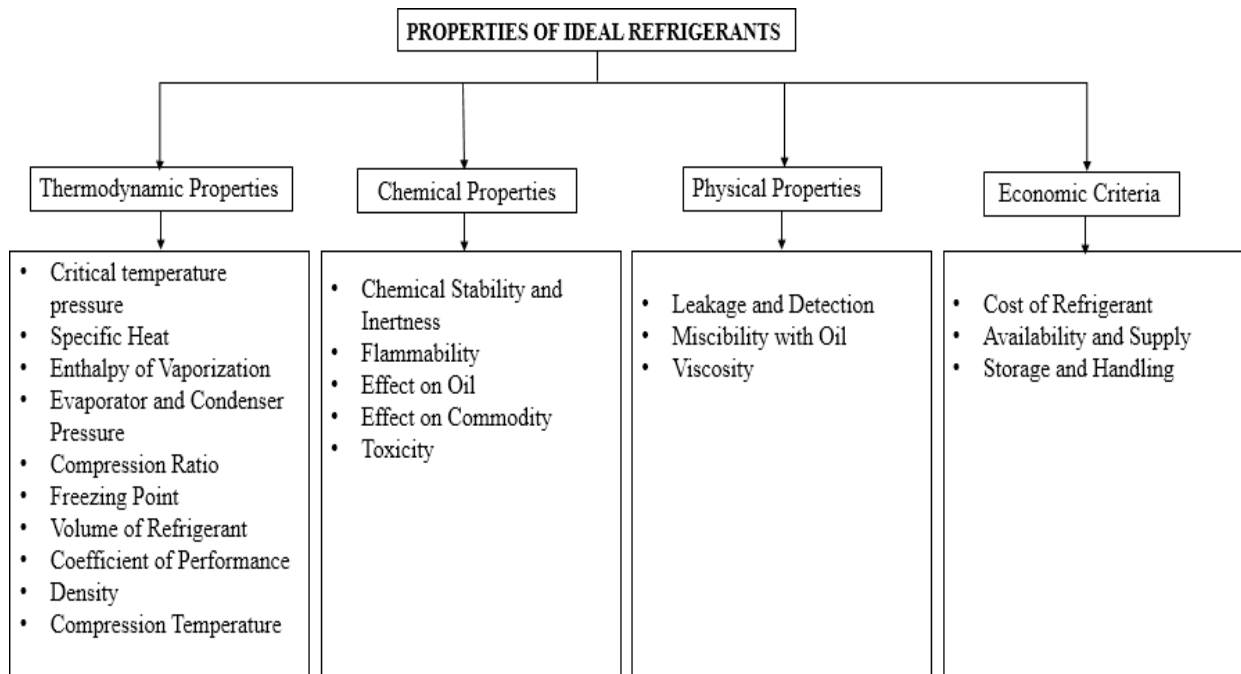

Fig. 4: Properties of ideal refrigerants

1.2.3.1 THERMODYNAMIC PROPERTIES

1. Critical Temperature and Pressure

The critical temperature of the refrigerant must be just about as high as could really be expected over the condensing temperature to have a more heat transfer at a steady temperature. With low critical temperature of refrigerants, extreme power utilization by the refrigeration system is required.

The critical pressure must be moderate and positive. An extremely high critical pressure will make the system bulky and if there is occurrence of low pressures, there is a chance of air leakage into the refrigerating system.

2. Specific heat

The specific heat of the liquid must be just about as little as could be expected. This guarantees that the irreversibility's related with throttling are little and there is more prominent subcooling of the fluid. Then again, the specific heat of vapour ought to be high to have less superheating of the vapour.

3. Enthalpy of vaporization

The enthalpy of vaporization need to be very high so that a least possible amount of refrigerant will achieve the wanted result, in other words, it rises the refrigeration effect.

4. Evaporator and condenser pressure

To avoid air leakage from atmosphere to refrigeration system evaporator and condenser pressure should be higher than atmospheric pressure. If leakage will be there efficiency of the system will decrease.

5. Compression ratio

The compression ratio should be just about as little as conceivable otherwise the leakage of refrigerant happens across the cylinder. Additionally, the volumetric efficiency will be influenced.

6. Freezing point

It must be just about as low as could really be expected or, in all likelihood there will be a chance of blockage of entries during stream of liquid through evaporator

7. Volume of refrigerant

This must be pretty much as little as conceivable to have a little size of the blower. The sort of Compressor is chosen by this worth. For refrigerants like R12, R500, R22 and so on, a reciprocating blower is appropriate. For others like R11 and water, a radial Compressor is required to deal with the huge volume.

8. Coefficient of performance

The Coefficient of performance has an immediate bearing on the running cost of the refrigeration system. Higher the extent of COP, lower will be the running expense. Since, the COP of any refrigeration system is restricted by the Carnot COP, for huge working pressure a multi-stage refrigeration system must be utilized. For example if we see CO₂ has an exceptionally low COP. Thus, its use as a refrigerant is challenging.

9. Density

The density of the refrigerant must be moderate as to compress high density fluid more work has to be done so, high density will increase the work of compressor. Also, in very low density refrigerant, pressure build up will be difficult to achieve.

10. Compression temperature

At whatever point a refrigerant gets compressed, there is an ascent in the temperature of the refrigerant bringing about the heating of the chamber dividers of the compressor. Due to this a good cooling setup required and also thermal losses will be more. Refrigerants having most reduced compression temperatures are subsequently better compared to others.

1.2.3.2 CHEMICAL PROPERTIES

1. Chemical stability and inertness

It must be chemical stable for the working scopes of temperature. Moreover, it should not respond with the materials of the refrigeration system or with any substance of contact. Further, it must be chemical inert in nature and should not go through polymerization responses at either the lower or higher scope of temperatures.

2. Flammability

The refrigerant must be inert and not burst into flames when exposed to high temperatures. From this perspective, CO₂ is the most reasonable as its difficult non-combustible yet in addition goes about as a fire-extinguisher. Butane, isobutene, ethane are exceptionally inconvenient as they burst into flames rapidly.

3. Effect on oil

The refrigerant must not respond with the lubricant oil else, there is a probability of loss of greasing up activity because of either thickening or diminishing of the oil. It should not be solvent in the oil else there will be decrease in the consistency of the lubricating oil.

4. Effect on commodity

In the event that the refrigerant is directly utilized for chilling, it ought not influence the Item kept in the adapted space. Additionally, for the situation where direct cooling isn't utilized, the refrigerant should in any case not influence the commodity if there is any kind of leakage.

5. Toxicity

Refrigerant should not be toxic as it will be used in various households and for many commercial purpose.

1.2.3.3 PHYSICAL PROPERTIES

1. Leakage and detection

Refrigeration system works in such high and low pressure ranges their might be a chance of leakage after long utilization of system. So, there should be some kind of indication in the refrigerant so that leakage can be detected. Odor of the refrigerant is the best way of indication of any leakage in the system.

2. Miscibility with oil

To avoid the reduction in the efficiency of refrigerating system and also the lubricating oil, refrigerant should not be miscible with lubricating oil.

3. Viscosity

It should be pretty much as little as possible to guarantee that the pressure drop in the system is just about as little as could really be expected. A low viscosity refrigerant will require less energy for its flow through the refrigeration system.

1.2.3.4 ECONOMIC CRITERIA

1. Cost of Refrigerant

The cost of the refrigerant immensely affects the general expense of the refrigeration system. Consequently, its expense should be pretty much as low as could be expected. From this perspective, NH_3 and water are obvious fit, yet their low thermodynamic and substance properties confine their utilization in a wide range of refrigeration.

2. Availability and Supply

The refrigerant should be effectively accessible on the lookout and in plentiful amount. This guarantees that the expense of the refrigerant isn't restrictive. A plentiful and free inventory of the refrigerant guarantees that refrigeration system will be planned specifically for use with them.

3. Storage and Handling

The refrigerant should be handled carefully as some of them are highly flammable and few of them are expensive as well. It should be stored in as little a pressure vessel as could really be expected. Extra care is required during charging and transportation as the possibilities of any mishappening is high at that time. Also, in the event that we need to deal with a poisonous or combustible refrigerant, then the expense included will be higher contrasted with the taking care of and capacity cost of non-toxic and non-combustible refrigerant.

Table 1: Properties of refrigerants used in domestic refrigerators [14]

No.	Code	Chemical formula	Molecular weight	Boiling point (°C) at 101.325 kPa	Critical temperature (°C)	Critical pressure (MPa)	Latent heat (kJ/kg)	Hazard to life group classification	Explosive limits in air, % by volume
1	12	CCl ₂ F ₂	120.93	-29.8	112	4.14	165.24	6	Nonflammable
2	134a	CF ₃ CH ₂ F	102.03	-26.1	101.1	4.06	216.87	6	Nonflammable
3	50	CH ₄ /methane	16.04	-161.5	-82.5	4.638	510.54	5b	4.9–15
4	170	C ₂ H ₆ /ethane	30.07	-88.8	32.2	4.891	487.03	5b	3.3–10.6
5	290	C ₃ H ₈ /propane	44.1	-42.07	96.7	4.25	423.33	5b	2.3–7.3
6	600	C ₄ H ₁₀ /butane	58.13	-0.5	152	3.8	385.77	5b	1.6–6.5
7	600a	C ₄ H ₁₀ /isobutane	58.13	-11.73	134.7	3.64	364.25	5b	1.8–8.4

1.2.4 CATEGORIES OF REFRIGERANTS

Refrigerants are separated into groups as per their chemical configuration. Following the disclosure that some of these refrigerants might be harmful to the climate, therefore study of alternates is going on so that less damage could happen to the environment. Categories of the refrigerants is divided into five types:

- CFC = ChloroFluoroCarbons
- HCFC = HydroChloroFluoroCarbons
- HFC = HydroFluoroCarbons
- FC = FluoroCarbons
- HC = HydroCarbons

1.2.4.1 CHLOROFLUOROCARBONS

Chlorofluorocarbons are refrigerants that contain chlorine. They have been restricted since the start of the 90's a result of their negative ecological effects. The transformation of hardware and system utilizing CFCs has not yet been finished. In actuality, the illegal market for this sort of refrigerants prospers around the world.

Examples: R11, R12 and R115

1.2.4.2 HYDROCHLOROFLUOROCARBONS

HCFCs were suggested as replacements of CFCs however, they were also banned by the various environmental organization around the globe in short duration of use. They contain less chlorine than CFCs and therefore have less Ozone depletion potential (ODP).

Example: R22, R123 and R124.

1.2.4.3 HYDROFLUOROCARBONS

HydroFluoroCarbons are refrigerants that contain no chlorine and are not unsafe to the ozone layer (ODP = 0). But their effect on global warming is extremely huge in contrasted to traditional refrigerants.

Examples: R32, R134a, R407C, R404A and R410A.

1.2.4.4 FLUOROCARBONS

FluoroCarbons doesn't contain chlorine and hence not harmful for ozone layer. Also, they are less dangerous as global warming agent.

Examples: R218

1.2.4.5 HYDROCARBONS

HydroCarbons are an exceptionally restricted answer for the ecological issues related with refrigerants. They cause no harm to the ozone layer (ODP = 0) and have no greenhouse impact (GWP<5), however, their flammability is an issue. Some European countries have restricted their use in domestic refrigeration systems. According to the standard IEC 355.2.20 permits the utilization of HCs in domestic refrigerators with refrigerant charge up to 150g [5].

Example: R600, R600a and R290.

1.3 OZONE DEPLETION AND GLOBAL WARMING POTENTIAL

An issue of developing worry for the current day climate is the effect of the different refrigerants on the ozone depletion and global warming of the climate which are accounted by the terms Ozone Depletion Potential (ODP) and Global Warming Potential (GWP). The main reason for the situation are the chlorine containing halogenated hydrocarbons, normally known as chlorofluorocarbons or CFC which are being utilized as refrigerants. When CFCs, are delivered from the system, they rise gradually into the stratosphere. Here they are surrounded by the UV light from the Sun, they delivers the chlorine atoms from the parent compound. It is this chlorine particle which responds with the ozone molecule. The free chlorine particle can again react with another ozone molecule. A chlorine atom, delivered by the activity of UV radiation on CFCs, can react multiple times with multiple ozone molecules and destroy the layer of ozone in the

stratosphere [6]. Apart from ozone depletion, CFC refrigerants also a reason for global warming of the planet. Some gases produce a greenhouse effect by trapping the heat in the lower atmosphere, which increase the temperature of the Earth. This happens because the greenhouse gases do not allow infrared radiation which came from the Sun to pass through them. Carbon dioxide is the main gas taking into the account for greenhouse effect. But global warming potential of one molecule is thousands times higher than one molecule of Carbon dioxide gas

Table 2: ODP and GDP of some common refrigerants [7]

Compositional group	Refrigerants	ODP	GWP (100 years horizon)
CFCs	R11	1	3800
	R12	1	8100
	R113	0.8	4800
	R114	1	9000
	R115	0.6	9000
HCFCs	R22	0.055	1500
	R123	0.02	90
	R124	0.022	470
	R141b	0.11	630
	R142b	0.065	2000
HFCs	R23	0.11	700
	R32	0	650
	R125	0	2800
	R134a	0	1300
	R143a	0	3800
	R152a	0	140
	R1270	0	3
Natural refrigerants	R290	0	3
	R600a	0	3
	R717	0	0
	R744	0	1

1.4 COMPRESSORS:

The function of compressor is to pump the refrigerant inside a pressure cycle system and to regulate it throughout the process. Basically, compressor converts low pressure vapours to high pressure vapours. In the essential pressure cycle, the compressor is situated between the evaporator and the condenser. Compressors can be introduced in one or the other single or multistage design, and can be associated with one another in arrangement or in parallel. The figure below shows different types of compressors:

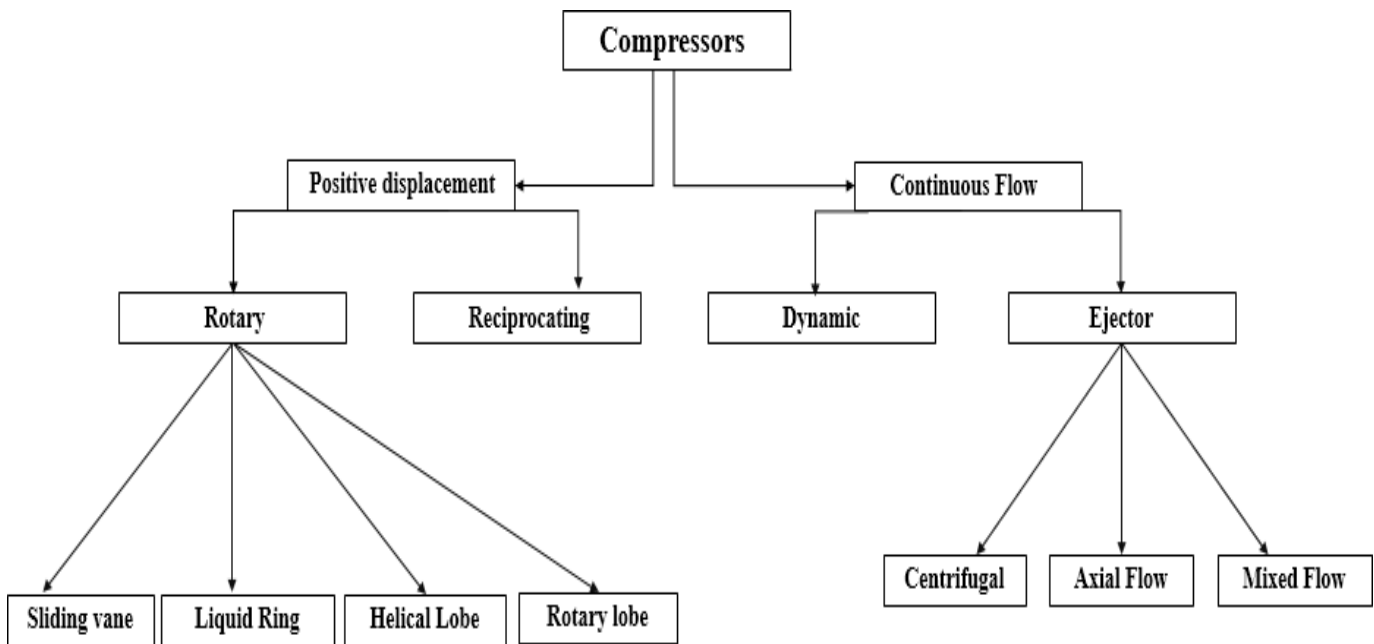

Fig. 5: Classification of compressors

1.4.1 RECIPROCATING COMPRESSORS

Reciprocating compressors comes under positive displacements category of compressor and also known as piston compressors. In the reciprocating compressors, rotary motion of the crankshaft converted into reciprocating motion. The reciprocating motion is done by piston and it goes up and down. At the point when the piston is at its absolute bottom, through the inlet valves superheated gas enters the compressor. At the point when the piston goes up, the inlet valve closes and the gas pressure increments, because of the diminished volume. The packed gas leaves the compressor when the pressure is sufficiently high to open the leave valve. Again when piston goes down it starts another admission of gas through the valves. The principle segment that is a cylindrical chamber with an appropriate piston, can be fabricated effectively with great precision. A hindrance of reciprocating compressors is the many moving parts, which makes it practically

difficult to keep away from vibrations. Another inconvenience is the "dead space". At the point when the piston is at its top position, a portion of the compacted gas will be caught in the space between the highest point of the cylinder and the chamber rooftop. The gas in the dead space brings about lower volumetric effectiveness, because less new gas is compacted on every cylinder stroke than the absolute volume of the chamber could really concede.

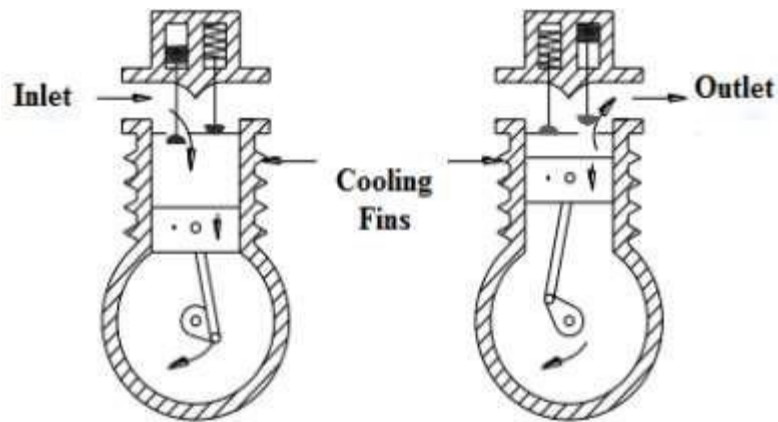

Fig. 6: Schematic diagram of reciprocating compressors [8]

1.4.2 ROTARY LOBE COMPRESSORS

A rotating lobe compressor comprises of indistinguishably synchronized rotors. The rotors are synchronized through utilization of an outer, oil-greased up, timing gear, which emphatically prevents rotor contact and which reduce clearance of meshing rotors to enhance productivity. This element additionally permits the compressor to be without oil in the gas path. Two rotor lobes rotate in a synchronized manner with the help motor and gear system shown in the figure. At the point when the rotor turns, gas is caught between the rotor lobes and the compressor casing. The pivoting rotor powers the gas from the inlet port, along the casing of the compressor, to the discharge port. Rotary lobe compressors are generally provided with the silencers to decrease their trademark high noise level. There are many advantages of rotary lobe compressors in compare to reciprocating compressors. Like there are few moving parts in rotary compressors so, less wear and tear of the parts. Also, problem of dead space is not there in rotary lobe compressors as it is big issue in reciprocating compressors. So, they high volumetric efficiency than Reciprocating compressors. Rotary lobe compressor doesn't have inlet and outlet valve system which helps in reduction of pressure drop at the valves and also vibration and noise get reduced as well. Figure 7 shows the schematic front and back view of the rotary lobe compressors

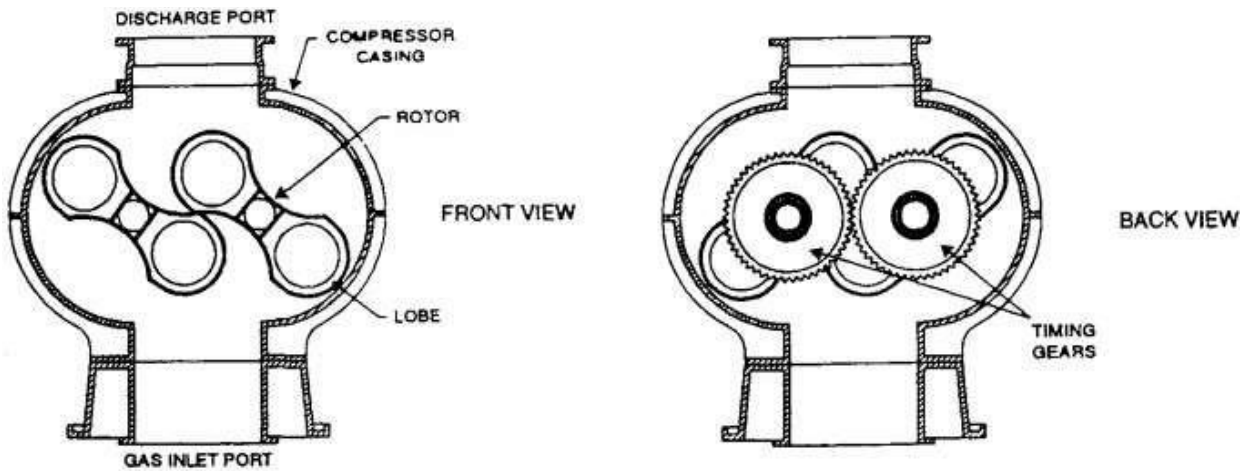

Fig. 7: Schematic diagram of rotary lobe compressor [9]

1.4.3 LIQUID RING ROTARY COMPRESSORS

Liquid-ring rotary compressors comprise of a round, multi-blade rotor that rotates in a curved (elliptical) casing. The curved casing is halfway filled with a fluid, which is normally water. As the rotor turns, the blade structures a progression of buckets. As the rotor turns, the buckets carry the fluid around with the rotor. Since the fluid follows the shape of the casing, the fluid then again leaves and gets back to the space between the blades. The space between the blades fills in as a rotor chamber. The gas inlet and release ports are situated at the inward diameter of the rotor chamber. As the fluid leaves the rotor chamber, gas is brought into the rotor chamber through the inlet ports. As the rotor keeps on pivoting, the fluid re-visitations of the rotor chamber and diminishes the volume in the chamber. As the volume diminishes, the gas pressure increments. As the rotor chamber passes the discharge port, the compacted gas is released into a gas/liquid separator and afterward to the cycle. Noise in these compressors are usually less as compare to other type of compressors. However pressure build up and volumetric efficiency of liquid ring compressors are comparatively less to other type of compressors as liquid is the compressing agent in these compressors. And losses in the liquid due to turbulence and due to other thermo physical properties makes liquid ring compressors less efficient. The schematic diagram of liquid ring rotary compressors is shown in the figure 8 given below:

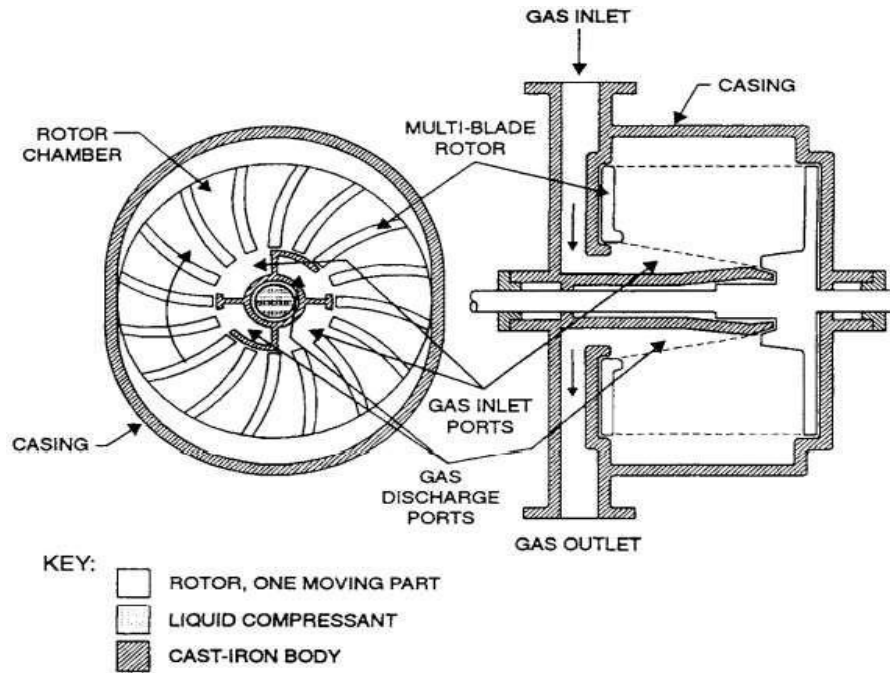

Fig. 8: Schematic diagram of liquid ring rotary compressors [9]

1.4.4 HELICAL LOBE COMPRESSORS

In helical lobe compressors two intermeshing rotors compress the gas. The gas is caught in the rotor pockets toward one side; it is compacted between the intermeshing rotors and released at the far edge. Some helical screw compressors work with liquid what's more, these are called overwhelmed screw compressors. The liquid gives a fluid seal around the rotors, consumes the heat of pressure, permitting the machine to create a more prominent pressure rise. The liquid should be eliminated from the gas after the pressure interaction.

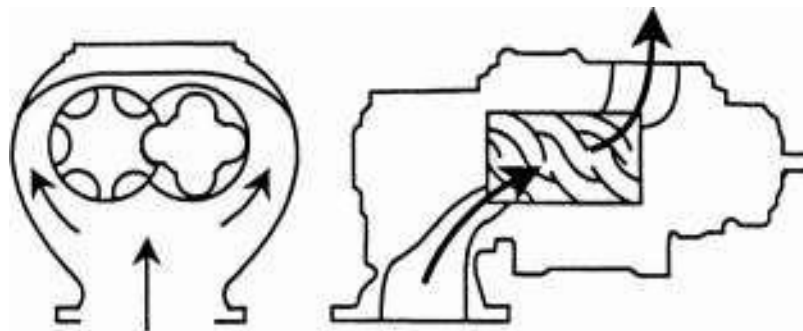

Fig. 9: Schematic diagram of helical lobe compressors [10]

1.4.5 CENTRIFUGAL COMPRESSORS

Centrifugal compressors are dynamic machines in which the quickly pivoting impeller speeds up the gas. In centrifugal compressors gas enters through the inlet nozzle axially and leave the

compressors radially that is perpendicular to the rotating shaft. On the rotating shaft impeller is mounted. Gas from the inlet nozzle hits the blades of the impeller which increases the resultant velocity of the gas. Diffusers are there around the impeller and gases pass through these diffusers and exit by the discharge nozzle. Diffusers decrease the high velocity exit gas into low velocity due to which a high pressure gas is built up at the end of discharge nozzle. The schematic diagram of centrifugal compressors is given in the figure 11.

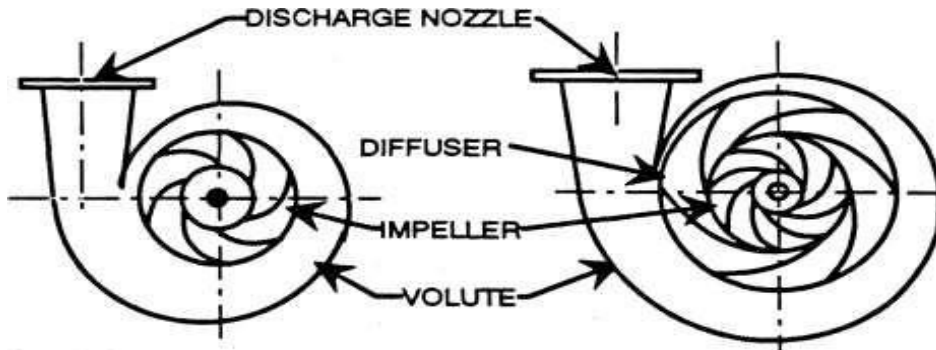

Fig. 10: Schematic diagram of centrifugal compressors [10]

1.4.6 AXIAL COMPRESSORS

Axial compressors are dynamic machines in which rotating blades are mounted over the main rotating shaft. A cylindrical casing which is tapered in the shape consists of stator vanes which are stationary. A gas enters through the inlet nozzle and is guided by the stator vanes into a proper orientation so that gas hits the rotating blades of the compressor. Rotating blades increase the velocity (kinetic energy) of the gas. Stator vanes also work as a diffuser and they reduce the velocity of the gas and due to this high pressure is attained at the discharge nozzle. The schematic diagram of centrifugal compressors is given in the figure 12.

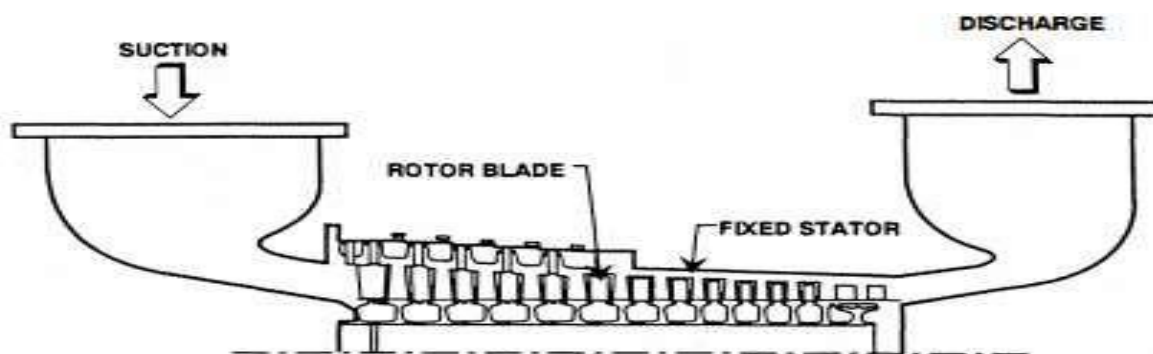

Fig. 11: Schematic diagram of axial compressor [9]

1.5 WORK OUTLINE

In this present work a study on single HCs refrigerant (R290) used in a New Induction Compressor Model has been done. The performance of this refrigerant is tested in reciprocating compressor (Induction model) which is used in domestic refrigerators. The performance results are compared with the Obsolete Compressor Model containing conventional refrigerant that is R134a. Although R134a has zero ozone depletion potential (ODP) and high performance in induction models of reciprocating compressors, the purpose for the alternate of R134a is its high global warming potential (GWP). Numerical and experimental study has been done on these refrigerants in this thesis work.

1.6 ORGANIZATION OF THE THESIS

The present documented thesis work is the performance analysis of two compressor models containing different refrigerants on the basis of experimental and numerical work, in which two refrigerants are tested in the induction models of reciprocating compressors. Presented work is documented in various chapters which are explained as:

Chapter 1: This chapter contains introduction to the thesis work by providing the background of vapour compression refrigeration system (VCRS), classification of various refrigerants and their properties and also compressors and their various types.

Chapter 2: Literature review which will brief about past research done in the field, detailing gaps in previous work and objectives about present thesis work.

Chapter 3: This chapter presents the detailed experimental setup, components of Induction models of reciprocating compressors and numerical methodology used for theoretical analysis for two different refrigerants.

Chapter 4: This chapter gives the results and comparison for present numerical and experimental studies.

Chapter 5: The conclusion and future scope of present thesis work is presented in this chapter.

CHAPTER 2

LITERATURE REVIEW

2.1 INTRODUCTION

In this chapter, all the previous studies on the performance of different refrigerants in compressor systems have been discussed. Although most of the studies are based on the vapor compression refrigeration cycle. In the studies, the basic motivation is to find a suitable refrigerant for a refrigeration system that is environmentally friendly and gives optimum performance. Input power, cooling capacity, coefficient of performance, discharge temperature are the key parameters to compare the performance of different refrigerants. These previous national and international studies provide enough knowledge which helped me in this thesis up to a larger extent. This chapter of the literature review is divided into two categories:

- Numerical study
- Experimental study

2.2 NUMERICAL STUDY

2.2.1 NATIONAL STATUS OF LITERATURE

Sharad et al. [11] did an exhibition investigation of the pressure pattern of a reciprocating compressor for refrigerator was completed. A mathematical recreation model of a refrigerant reciprocating compressor has been created in MATLAB Simulink R2009a. A particular mathematical simulation model of the entire vapor pressure refrigeration system has been created coupling diverse simulation models for every component (i.e., evaporator, compressor, condenser and extension valve), more itemized numerical models has been consolidated in the simulation model of the compressor and flexibility to various setups without changing the program. The refrigerants taken for the examination in this paper is R134a. A parametric investigation of reciprocating compressors has been conducted. The recreation model had the option to assess the mass stream rate (\dot{m}), refrigeration impact (Q), compressor work (W_c), volumetric effectiveness and coefficient of performance (COP) of the entire refrigeration system. Results introduced of COP show, there is no impact of compressor speed on it however it changes with the evaporator temperature showing its reliance on evaporator temperature. The outcome introduced of refrigeration impact and compressor work shows that both rely upon the compressor speed, evaporator temperature and L/D proportion. The outcome introduced of volumetric productivity

shows that it will just rely upon evaporator temperature and doesn't relies upon compressor speed and L/D proportion. The outcome introduced of mass stream pace of refrigerant shows that it will relies upon compressor speed, evaporator temperature and L/D proportion. The simulation model of the reciprocating compressor offers adaptability in dealing with complex compressor hardware and fast versatility to new plans by expansion or expulsion of the required components.

2.2.2 INTERNATIONAL STATUS OF LITERATURE

Douglas et al. [12] describes the Cost based model to find the alternate of R22. In this model both thermodynamic and transport properties are taken into account. This model is computer base model for optimization of parameters for the cost and performance of refrigerant. A window air conditioning system were taken for this model analysis and several leading replacements for R22 were analyzed. In his model two leading R-22 alternates that is R-407C and R-410A had optimal costs and it is almost near to R-22. Also he concluded R290 showing the best performance out of all other alternatives however its cost is increased because of requirements associated with its high flammability.

Palm et al. [13] examines the chance of charge decreases, in heat pump system and refrigerator. It was shown that a move towards indirect system, utilizing auxiliary refrigerants, on both the cold and the hot side of the system may bring about extensive decrease of charge. Although, this decrease may come at the expense of somewhat decreased system execution, which in itself is inconvenient from an ecological perspective. He stated that by choosing compact designs the charge might be decreased to incredibly low levels. In particular, small scale channel heat exchangers can be utilized for arriving at low charge. He also mentioned that for indirect system, the measure of refrigerant settled in the compressor oil which accounts some extra charge. A potential solution to diminish this extra charge is to utilize compressor with less oil.

Dalkilic et al. [14] did a theoretical exhibition concentrate on a conventional vapor-pressure refrigeration system with refrigerant blends dependent on HFC134a, HFC152a, HFC32, HC290, HC1270, HC600, and HC600a was accomplished for different proportions and their outcomes are contrasted and CFC12, CFC22, and HFC134a as conceivable elective substitutions. Theoretical results showed that the entirety of the elective refrigerants explored in the investigation have a somewhat lower execution coefficient (COP) than CFC12, CFC22, and HFC134a for the buildup temperature of 50 °C also, evaporating temperatures going between -30 °C and 10 °C. Refrigerant mixes of HC290/HC600a (40/ 60 by wt. %) rather than CFC12 and HC290/HC1270 (20/80 by wt. %) rather than CFC22 are discovered to be substitution refrigerants among different options in his

theoretical analysis.

Bolaji et al. [15] theoretically investigated the performance of R290, R600 and R1270 as replacement of R22. The study was investigated in vapor compression refrigeration system by applying a sub-cooling heat exchanger. In his results, saturated vapor pressure and specific volume of R290 and R1270 are almost identical to R22. The cooling capacity of all three alternates were found better than that of R22. The thermo physical properties of R290 and R1270 almost similar with R22 and the two refrigerants displayed better performance over R22 in sub-cooling heat exchanger refrigeration system. However R600a shows better performance when it came to per ton of refrigeration with respect to power which is also lower than other refrigerants and hence it give better COP. But, due to its saturation pressure and specific volume which is very much different from R22, it require a completely different design of compressor apart from design of R22 compressor.

Subaintoro et al. [16] examined seven R22 potential substitute refrigerants that is R134a, R407C, R437A, R744 (CO₂), R1234yf and R290 (propane). It was theoretical study taking four parameters for the performance analysis which are COP, cooling capacity, Compressor discharge pressure, Compressor discharge temperature. His study told that as far as broad system performance, R290 is likewise the most unrivaled of all the R22 substitutes followed by R134a. R744 is the most minimal positioned.

2.3 EXPERIMENTAL STUDY

NATIONAL STATUS OF LITERATURE

Ravi et al. [17] objectified his study for the alternate of R12 refrigerant in the air conditioning system in the automobile. Also for this study conventional mineral oil is used as lubricant in the system for the replacement of PAG oil. The PAG lubricants have different additives which are unique for different compressors. In his study the replacement of R12 is targeted as R134a but for the compatibility with mineral oil, blend of hydrocarbons is used (45.2% R290 and 56.8% R600a) in the proportion of 91% and 9%, respectively by mass. Experimental work is performed in the form of four tests to check performance of air condition system of automobile. Tests will be performed with the refrigerant R12 and blend of hydrocarbons. In the results performance comparison can be concluded from tests. From the tests it can be concluded that Blend of R134a/R600a/R290 is giving 25-33% more refrigerating capacity as compare to R12 but also the compression work is 43% more than R12, due to this COP of blend of R134a/R600a/R290 is reduced 5-15%. During the tests, the engine coolant temperature does not vary significantly for the two refrigerants. There is no significance change for suction pressure and temperature during all the tests. However, for the blend of R134a/R600a/R290 there is increase in discharge pressure by 7-10% and reduction in discharge temperature by 11-13%. As, life of the compressor increases by reduction in discharge temperature and the compressor work increases with the increment of discharge pressure. Also replacement of PAG oil with the mineral oil is helpful for system efficiency for longer time.

Patel et al. [18] also did an experimental study on VCR system which is used for both cooling and heating simultaneously. Refrigerants used in his study are R22, R134a, R407C and R410A. In his experimental results it is found that with R134a as refrigerant in the system gives the COP 20% more than that of R22 and decrement of 10% and 18% with R407C and R410A respectively. So R134a is most suitable elective refrigerant.

Dhamneya et al. [19] used nanoparticle TiO_2 with R134a in evaporative cooled refrigeration system which means and evaporative cooled system has been coupled with the condenser of VCRS. From the study it is concluded that COP of the system increases upto 51% as compared to conventional VCRS.

Nair et al. [20] have suggested nanofluid based refrigerant to improve the performance to R134a refrigerant in VCRS. Further PAG oil is used as lubricating fluid in compressor and thus blend of R134a/PAG/ AL_2O_3 is prepared. Performance parameters like discharge temperature, compressor IP, CC and COP are being measured and compared with the refrigerant without nanofluids. It is found that blend with AL_2O_3 nanofluid gives better performance as it improves the thermophysical properties the traditionally used R134a refrigerant and COP of the system is improves by 6.5% after doping of AL_2O_3 in the refrigerant.

Gill et al. [21] investigated the performance of R134a/LPG blend in VCRS instead of R134a and it is found that COP increases about 15%-17% and discharge temperature of system decreases by 2% -14%. Also miscibility of R134a/LPG blend with lubricating PAG oil is decent enough.

Joshi et al. [22] used Al_2O_3 as nanoparticle in R600a in a mass fraction ranges from 0.02% to 0.1%. His study concluded 0.1% of Al_2O_3 in R600a improves systems COP by 37.2% and compressor discharge pressure increases by 8.9% while IP of compressor decreases by 28.7% as compare to R600a in the system.

INTERNATIONAL STATUS OF LITERATURE

Cabello et al. [23] also sets a comparison between R134a, R22 and R407. In this work the impact of the evaporating pressure, condensing pressure and superheating level of the vapor on the performance of a refrigeration plant utilizing three diverse working fluids has been studied. The first conclusion derived from the work is that the refrigerant mass stream rate is to a great extent dependent on suction conditions. He also concluded that the mass stream rate influenced by the pressure proportion, and particularly by the evaporating pressure. At the last conclusion of his study he stated that with increasing in compression ratio COP of R22 declined as comparison to other two refrigerants.

Somchai et al. [24] presents an experimental investigation on the utilization of hydrocarbon blends to supplant HFC134a in a domestic refrigerator. The hydrocarbons explored are propane (R290), butane (R600) and isobutene (R600a). A refrigerator intended to work with HFC-134a is utilized in the test. The energy consumed, compressor power and refrigerant suction as well as discharge temperature and pressure is measured. The refrigerant blends utilized are separated into three

gatherings: the combination of two hydrocarbons, the combination of three hydrocarbons and the combination of two hydrocarbons and HFC-134a. The examinations are led with the refrigerants under a similar no load condition at a surrounding temperature of 25°C. The outcomes show that propane/butane 60%/40% is the most suitable elective refrigerant to HFC-134a.

Fatouh et al. [25] tried LPG of 60% propane and 40% butane as a drop-in substitute for R134a in a single evaporator fridge with an all-out volume of 10 ft³ (0.283 m³). Results showed that R134a with a capillary tube length of 4 m and charge of 100 g or LPG with capillary tube lengths from 4.0 to 6.0 and charge of 50 g or more fulfill the necessary cooler air temperature of 12°C. The most minimal electric energy utilization was accomplished utilizing LPG with mix of capillary tube length of 5 m and charge of 60 g. This mix accomplished higher volumetric cooling limit and lower cooler air temperature contrasted with R134a. Pull-down time, pressure proportion and power utilization of LPG cooler were lower than those of R134a fridge by about 7.6%, 5.5% and 4.3%, separately. Likewise, real COP of LPG cooler was higher than that of R134a by about 7.6%. Taking everything into account, the proposed LPG is by all accounts a fitting long haul contender to replace R134a in the current cooler, apart from capillary tube length and initial charge.

Rocca et al. [26] investigated three HFC alternatives (R417A, R422A, R422D) for the replacement of R22 refrigerant. Performance of Vapor Compression refrigeration cycle was measured with these alternatives and several tests were performed. He also calculated the emission of CO₂ while using different refrigerants. Results of his study showed that performance and emission of CO₂ is better for R22 rather than the alternatives. However ODP for R22 is high while HFC refrigerants have zero ODP value. Also, HFC alternates showed good compatibility with mineral oil.

Olatunbosun et al. [27] did a comparative study between R600A, R510A, and R134a. The outcomes acquired showed that the COP of the system utilizing the two hydrocarbon refrigerants was higher than the COP got utilizing R134a as a functioning liquid. The two hydrocarbon refrigerants performed better compared to R134a, however R510A gave the best among all it showed the most minimal discharge pressure of and the most elevated refrigerating effect.

Nawaz et al. [28] examined the performance of R290 (propane) and R600a (isobutene) alternative for R134a (HFC) for heat pump water heating (HPWH). A segment based model was utilized to calculate the performance of the HPWH system. Key execution parameters that is energy factor, first hour rating, condenser release temperature and complete refrigerant charge were examined. Investigation results propose that both elective refrigerants could give similar execution to that of

the pattern system containing R134a. As a drop-in other option, R290 was discovered to be a superior substitute for R134a, though R600a is relied upon to give comparable performance if the compressor size is big to give comparable heating capacity. Huge decreases in system charge and lower condenser discharge temperatures were recognized as extra advantages.

Ario et al. [29] experimentally investigated the performance of domestic compressor with two distinct refrigerants that is R134a and R290/R600a. Cooling limits and different boundaries were resolved for a refrigeration cycle working between temperature cutoff points of -25°C (evaporator temperature) and 42°C (condenser temperature). The refrigerants utilized in the refrigeration cycle investigation were R134a and R290/R600a. Boundaries, for example, refrigerating limit, mass stream rate, pressure work, condenser limit and Coefficient of Performance (COP) were figured for every refrigeration cycle. In the end of his experimental work he concluded that the refrigeration system was intended to run on R134a and R290/R600a separately and the execution of every one of these refrigerants analyzed. At the working temperatures considered, COP of R134a is better than R290/R600a. As per the outcomes, mass flow rate of R134a is higher because it's specific heat of vaporization is lower. Despite the fact that compressor size was fixed at 125W for the two refrigerants, refrigerating capacities with respect to the refrigerants are distinctive with R134a refrigeration cycle having a higher COP of 3.01. Refrigerating limit of R134a is higher than that of R290/R600a by 38.3W. Also COP of R134a is higher than that of R290/600a. Hydrocarbon refrigerants have combustibility issue. The amount of refrigerant charge of R134a for a given refrigeration system is higher than that of R290/R600a. This is because of high latent heat of vaporization of R290/R600a and subsequently its low mass flow rate.

Flores et al. [30] have done experimental work with three identical domestic refrigerators by replacing the refrigerant R134a with R1234yf. Objective of this of study is to find the optimum amount of refrigerant R1234yf required in system and comparison of both refrigerants on the basis of their performance in VCRS. In his study average amount of R1234yf required is 92.2 g and it is 7.8% less than R134a in the same system. While power consumption of R1234yf is 4% higher than R134a.

Zenxi et al. [31] have done experimental work using two refrigerants differently in GEHP (Gas engine heat pump). Using R134a and R152a refrigerant in GEHP heating performance parameters including compressor efficiency of the system is tested and compared between them. From the experimental analysis this can be concluded that R152a is showing improvements in performance

parameters as R152a shows improvement in isentropic efficiency to 3.5-10.7% and in volumetric efficiency 5.8-7.3% as compare to R134a. Also, with R152a there is high heating and compressor efficiencies.

Chen et al. [32] tested the performance of alternate refrigerants that is R152a and R1234yf in place of R134a in AC system. In his study it can be concluded that R1234yf is low GWP than R134a but it have same working pressures and temperature conditions as R134a moreover, it have 11% and 16% less CC and COP as compare to R134a. While R152a has 13% and 6% higher CC and COP respectively.

Sánchez et al. [33] tested low GWP refrigerants (R1234yf, R1234ze (E), R600a, R290 and R152a) as alternates for R134a in same VCRS. From the study it can be concluded that R290 shows significant increment in CC, COP, and IP as compare to R134a. While, R600a and R1234ze (E) shows reduction in CC and COP.

Makhnatch et al. [34] have done experimental analysis of R134a and R450A (blend of R134a and R1234ze (E)) in small refrigeration unit from which it can be concluded that R450A have CC 9.9% lower and COP 2.9% less than R134a. Which means R450A is not suitable replacement for R134a as refrigerant.

2.4 GAPS IN LITERATURE REVIEW

Based on the above literature studies there are some gaps which have been identified and upon those gaps research work can be done to improve the system which can be summarized as follows.

1. Less work on pure mono refrigerants like as R600a and R290 as single refrigerants instead of blends which are used in most of the previous studies.
2. Less information of the components of the hermetic reciprocating compressor.
3. More experimentation work could be performed by increasing the number of testing.

2.5 THESIS OBJECTIVES

In this thesis work performance of 2 hermetic reciprocating compressors with two different refrigerants that is R134a & R290 is presented. Objectives of the work are summarized as follows:

1. Numerical analysis of the key parameters like mass flow rate, power consumption, cooling capacity, coefficient of performance of the system with the mentioned two different refrigerants.
2. Experimental study of the hermetic compressor system with two alternate refrigerants to find the major key parameters with actual working conditions.
3. A comparative analysis between mentioned two refrigerants on the basis of numerical and experimental studies.
4. Study of thermo physical properties like density, latent heat of vaporization, saturated pressure of refrigerants.
5. Detail information of each and every component of hermetic reciprocating compressors.

CHAPTER 3

EXPERIMENTAL AND NUMERICAL METHODOLOGY

3.1 INTRODUCTION

In this chapter, complete methodology of the work is explained in detail. This particular chapter is divided into sections. In first section, theoretical approach for the study is explained which includes research of particular refrigerants and their properties for the study and in the second section experimental work is explained. Testing equipment, experimental setup, measuring devices and refrigerants used for the study of experimental behavior hermetic compressor is provided by LG Electronics, INDIA.

3.2 THEORETICAL STUDY

3.2.1 STUDY OF REFRIGERANTS

Motive behind this work is to replace HFCs like R134a completely from domestic compressors. Refrigerants starting from CFCs to HCs have been used in domestic refrigerators over a period of time. In LG domestic refrigerators initially started with CFCs gas R12 and then they shifted to R134a as sustainable source of refrigerant in domestic induction models of compressors. Also, they started R600a when inverter model was launched by them in the market. Due to climatic disturbances caused by the R134a, company even wants to replace them from induction models of their compressor. So, R600a and R290 are taken into the consideration as alternatives in terms of HCs which are ecofriendly. So study of two different compressor models containing R290& R134a refrigerants used in this work is discussed as following:

3.2.1.1 TETRAFLUOROETHANE (R134a)

The refrigerant R134a is non-flammable, non-explosive, incombustible non-poisonous, non-corrosive, and will not cause damage to the ozone layer. Despite of having relatively high water solubility, it is not good for the refrigeration system, if there is a small amount of water under the action of lubricating oil then it will produce acid, carbon dioxide or carbon monoxide and that will corrode the metal or produce the Copper plating function, so it requires higher drying and cleaning of the system.

3.2.1.2 PROPANE (R290)

It has very low GWP (3) and no ODP (0). It is not affected by F-Gas regulation, it is an inexpensive refrigerant. Basically it has low final compression temperatures. It has small filling quantity due to good density/evaporation heat ratio. It has good material compatibility, good print position and non-hazardous to water. The major disadvantage of using R290a is that it is highly combustible.

Table 3: Property comparison of R134a & R290 [5], [6]

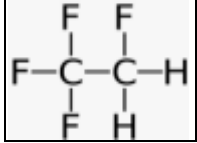
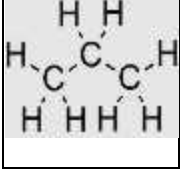
Property	R-134a	R-290
Chemical Formula	CF ₂ CH ₂ F	C ₃ H ₈
Molar mass	102.03 g.mol ⁻¹	44.1 g.mol ⁻¹
Melting point	169.8 K	85.55 K
Boiling point	246.8 K	231.08 K
Latent heat (-25°C)	216 kJ/kg	423.33 kJ/kg
Critical Temperature	374.25 K	369.85 K
Chemical Bond Diagram		

3.2.2 ASHRAE CONDITIONS

ASHRAE (American Society of Heating, Refrigerating and Air-Conditioning Engineers) is an association given to the progression of indoor-climate control innovation in the heating, ventilation and cooling (HVAC) industry. In 2018, the association has in excess of 56,000 individuals from more than 132 countries. ASHRAE principles are grown so HVAC and refrigeration experts approach state-of-the-art methodology when testing, introducing and planning equipment. They likewise give steady wording and data to HVAC experts. These norms and rules are dependent upon constant support, and society individuals can change the data. ASHRAE distributes a month to month diary, and has innovation assets recorded. ASHRAE has a members of technical committees, they make all the standards with the help of recorded data and public review. The group of members revise the standards after every five years to keep the information updated. According to applications of refrigeration compressors are categorized into 3 types discussed below:

Low back pressure (LBP): Used where evaporation temperature low is required such as Refrigerators, deep freezers, display windows, frozen food cabinets and other preservers.

Medium back pressure (MBP): Used where medium evaporator temperature is required such as, walk-in coolers, drink coolers, ice makers, freezers and Fresh-food cabinets etc.

High back pressure (HBP): Used where high evaporator temperature is required dehumidifiers, ice makers, dryers, etc.

ASHRAE have testing conditions of all the three types of compressor applications. These conditions are followed in industries which are in hermetic compressor manufacturing.

Table 4: ASHRAE testing standards [35]

Test Conditions (Rating Point)	Application	Evaporating Temperature °C	Condensing Temperature °C	Suction Temperature °C	Liquid Temperature °C	Ambient Temperature °C
ASHRAE 32	LPB	-23.3333	54.4444	32.2222	32.2222	32.2222
ASHRAE 46	M/HPB	-6.66667	54.4444	32.2222	32.2222	32.2222
	HPB	7.22222	54.4444	35	46.1111	35

3.2.3 NUMERICAL ANALYSIS:

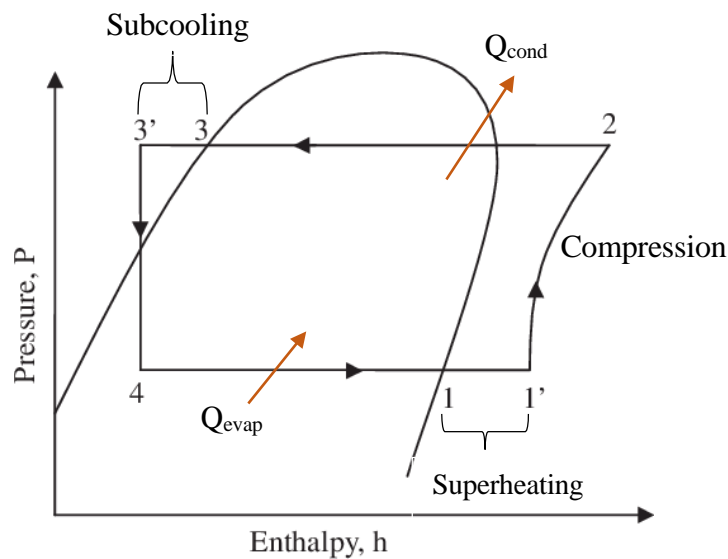

Fig. 12: Pressure v/s enthalpy graph for VCRES with subcooling and superheating

Evaporator

Heat absorbed by the refrigerant in the evaporator (Q_{evap}) is compared as [36]:

$$Q_{\text{evap}} = m_r (h_{1'} - h_4) \quad (1)$$

Where, $h_{1'}$ = specific enthalpy of refrigerant at the outlet of evaporator and h_4 = specific enthalpy of refrigerant at the inlet of evaporator.

m_r = mass flow rate of refrigerant (kg/s)

Theoretically mass flow rate of refrigerant by compressor is calculated as:

$$m_r = V \times \rho \times \text{rpm} \quad (2)$$

Where, V = volumetric displacement by piston (m^3)

ρ = density of vapour refrigerant into the compressor (kg/m^3)

rpm = rpm of the reciprocating compressor (rev/ min)

Compressor

The isentropic power input to compressor (J/s is expressed as) [36]:

$$W_c = m_r (h_2 - h_{1'}) \quad (3)$$

Where h_2 = enthalpy of refrigerant at outlet of compressor.

Condenser

The heat rejected by the condenser (Q_{cond}) to the atmosphere is given by [36]

$$Q_{\text{cond}} = m_r (h_2 - h_{3'}) \quad (4)$$

Where $h_{3'}$ = specific enthalpy of refrigerant at the outlet of condenser (J/kg)

Capillary Tube

In capillary tube the enthalpy remains constant,

$$h_{3'} = h_4$$

From first law of thermodynamics, the measure of performance of refrigerator cycle is the coefficient of performance and is the refrigerating effect produced per unit of power input required it is expressed as [35]:

$$\text{COP} = Q_{\text{evap}}/W_c \quad (5)$$

Compressor pressure ratio (P_r) is given as:

$$P_r = P_{\text{dis}}/P_{\text{suc}} \quad (6)$$

Where P_{dis} = refrigerant vapour pressure at the compressor discharge (N/m^2) and P_{suc} = refrigerant vapour pressure at the compressor section (N/m^2)

3.1 EXPERIMENTAL STUDY

In this study two hermetic reciprocating compressors are taken for the testing of the two refrigerants (R134a and R290). Testing of compressors have been done in the testing chamber called as “Calorimeter”. In this section detailing of hermetic compressors, experimental setup, and experimental procedure is discussed.

3.1.1 HERMETIC RECIPROCATING COMPRESSOR

Hermetic compressors are those compressors in which electrical motor and mechanical compressor system kept in a single steel shell body. The steel shell body of the compressor is welded from outside and due to this maintenance of hermetic compressors cannot be guaranteed. [37]

3.1.1.1 COMPONENTS OF COMPRESSOR





Fig. 13: Assembly of hermetic compressor (top view) [LG. electronics India]







Fig. 14: Assembly of hermetic compressor (side view) [LG. electronics India]

The compressor comprises of a number of parts. They are described in the following table:





Table 5: Components of hermetic compressor

Part name	Figure	Description
Upper shell		It is an enclosure for the compressor pump.
Cylinder block		It is the base over which the total assembly is done. It houses the crankshaft and the piston.
Crankshaft		It converts the rotary motion into reciprocating motion. It is assembled with the rotor and the connecting rod to the piston.

<p>Motor</p>		<p>It is the electrical component in the compressor assembly. It provides the required power to run the compressor.</p>
<p>Lower shell</p>		<p>The compressor pump is enclosed in this shell. The lubricant oil circulates through the pump within this enclosure.</p>
<p>Piston</p>		<p>It has the main function of compressing the refrigerant which enters into the cylinder bore. It is connected the crankshaft with the help of a connecting rod.</p>
<p>Connecting rod</p>		<p>It moves the piston to and fro to compress the refrigerant gas.</p>
<p>Cover silencer</p>		<p>The compressed gas exits the cylinder through the cover silencer. It reduces the noise and vibration during the operation.</p>

<p>Oil picking tube</p>		<p>It circulates the lubricant oil filled in the shell into the cylinder bore through the crankshaft.</p>
<p>Rotor</p>		<p>It rotates with the help of power from the motor and in turn moves the crankshaft.</p>
<p>Protector</p>		<p>It provides protection to the three terminals present on the outside of the lower shell.</p>
<p>Suction valve</p>		<p>It acts as an inlet valve for the refrigerant entering into the cylinder bore.</p>

<p>Overload Protector</p>		<p>To protect the motor of the compressor from over voltage.</p>
<p>Spring valve</p>		<p>It pushes back the discharge valve into its position after the exit of the refrigerant.</p>
<p>Valve plate</p>		<p>Suction and discharge of refrigerant takes place through the suction and discharge ports of valve plate. It houses the discharge valve along with the retainer with the help of rivets.</p>
<p>Suction gasket</p>		<p>It is placed before the suction valve and is graded according to the top clearance between Cylinder bore and piston head.</p>
<p>Discharge gasket</p>		<p>It is placed after the discharge valve and is covered with a head cover.</p>

Suction muffler		It reduces the noise generated due to the flow of refrigerant.
Suction pipe		The refrigerant enters into the compressor through this pipe.
Discharge pipe		The compressed refrigerant comes out of the compressor through this pipe.
Process pipe		Lubricant oil is charged and discharged through this pipe.
Ear mounting		It is used for mounting the compressor on the refrigerator.

There are two types of motors are used in manufacturing of hermetic compressors which are:

- Induction motor
- Inverter motor

In Fig. 16 (a) and (b) stator and rotor assembly of Induction and inverter model is shown

respectively. Induction motors have two windings of wire that is main winding and sub winding. Sub winding is used for providing initial torque to the motor when motor starts and after providing torque the circuit of sub winding get open by PTC (positive thermal coefficient). Induction motors are larger in size than inverter motors. On the other hand inverter models doesn't have sub windings and they contain PCB which contains data processing units and sensors readers.



Fig. 15: (a) Induction motor

Stator

(b) Inverter motor

Rotor

In industries R134a refrigerant is used in induction models and R600a is used in inverter models of compressor. In this study induction model of compressors are used whose specifications are mentioned in Table 6. All the experimentation work is done in LG electronics Laboratories.



Fig. 16: Hermetic reciprocating compressor [LG. Electronics, India]

Specifications:

Table 6: Specifications of testing compressors

1. Company	LG. Electronics India pvt. Ltd.
2. Compressor Type	Reciprocating Compressor
3. Model	CMAXXXXXXG, CMAXXXXXXM
4. Motor	Induction motor (RSIR, PTC)
5. Voltage	220-240
6. Vol. displacement by Piston	6.9 cm ³
7. Bore dia. of cylinder block	24 mm
8. Stroke	15mm
9. Clearance	0.2mm
10. Refrigerants used	R134a & R290
11. Application	Domestic Refrigerator, deep freezers

3.1.2 EXPERIMENTAL CHAMBER:

To investigate the performance of hermetic compressor in labs, Calorimeter is the best testing machine to simulate the performance with real conditions. However it is restricted to small size compressors and big size compressors can't be tested in it. Basic structure of calorimeter is similar to any other refrigerator system containing condenser, evaporator, expansion valve and compressors with thermocouples, pressure gauges and sensors at suitable places in the system.

In this experimentation Secondary fluid Calorimeter is used and a simplified schematic diagram of the setup is shown in the figure 18.

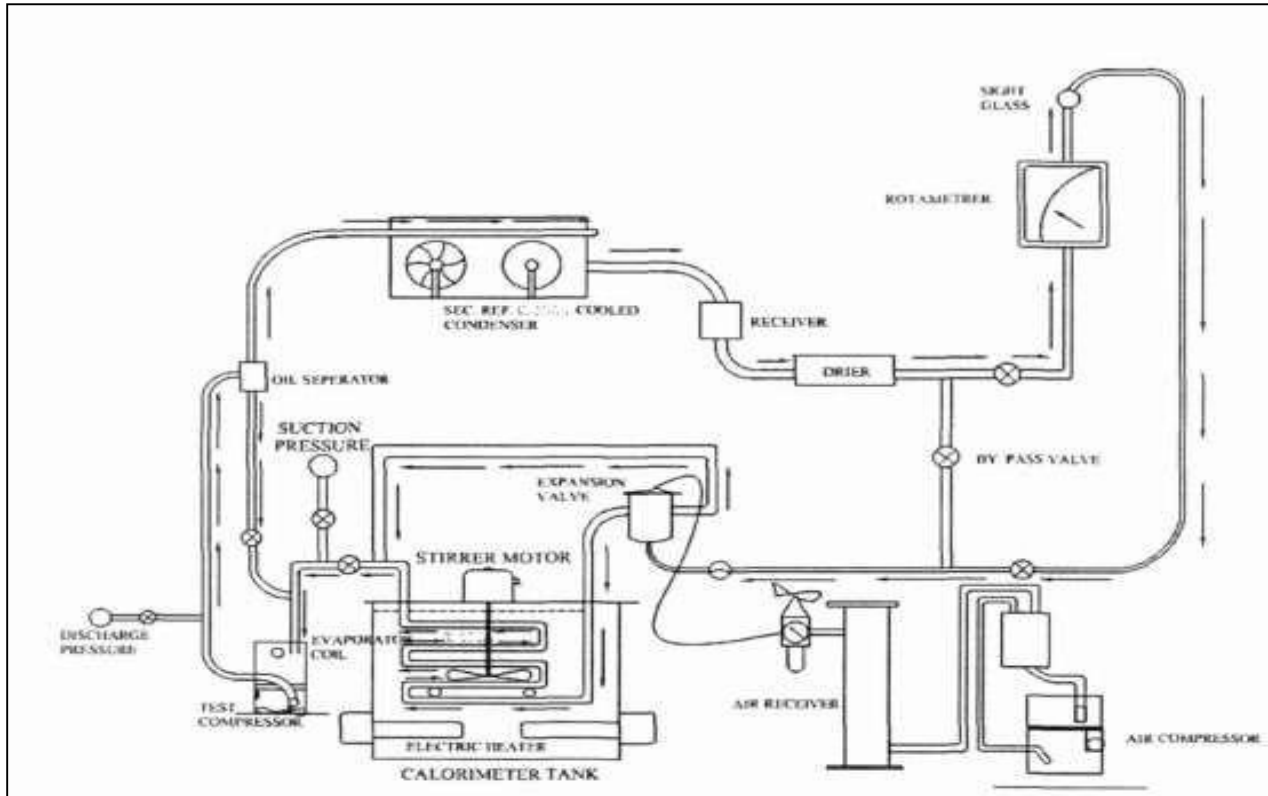

Fig. 17: Schematic diagram of secondary fluid calorimeter [38]

Description

- The secondary fluid calorimeter have a calorimeter chamber in which an electrical heater with secondary fluid is present to provide heating load in the evaporator zone.
- Electrical heaters, a pneumatic controlled expansion valve, drier, liquid receiver, rotameter, stirrer, fan, thermostats, pressure etc. are shown in the schematic lay out of the testing setup of secondary fluid calorimeter.
- The calorimeter chamber also consist of evaporator of primary refrigeration system with R141b as a secondary refrigerant. One end of Evaporator coil tubing connected to the exit of an automatic expansion valve and another end connects suction line of the compressor which is under test.
- Adjustment of suction pressure is done by this expansion valve. Expansion valve is controlled by pneumatic controllers.
- The condenser present in the calorimeter framework removes the heat added in the calorimeter and heat due to compression. Refrigerant gas is condensed passes through the annular space between the two tubes in which circulated secondary fluid (R141b) carry the heat away.

- Liquid receiver is present to collect the condensed refrigerant. The circulation of secondary refrigerant through the condenser is controlled by automatic valve operated with sensor. The circulation of secondary fluid is adjusted according to the compressor discharge pressure by the sensor automated valves.
- A small cabin is present in the calorimeter in which testing compressor is placed. During test, cabin is closed and a fan is provided at the back for compressor under test to maintain the ambient temperature. Heaters and chilled refrigerant flowing through tubes, maintain the temperature of air flowing above the compressor.
- An insulation is provided for the calorimeter in such a way so that heat leakage does not exceed 5% of the cooling capacity of the compressor.
- ISO 1662 standards are followed and adjustments are made in such a way that the refrigerant pressure does not go beyond the safety limit for the experiments.

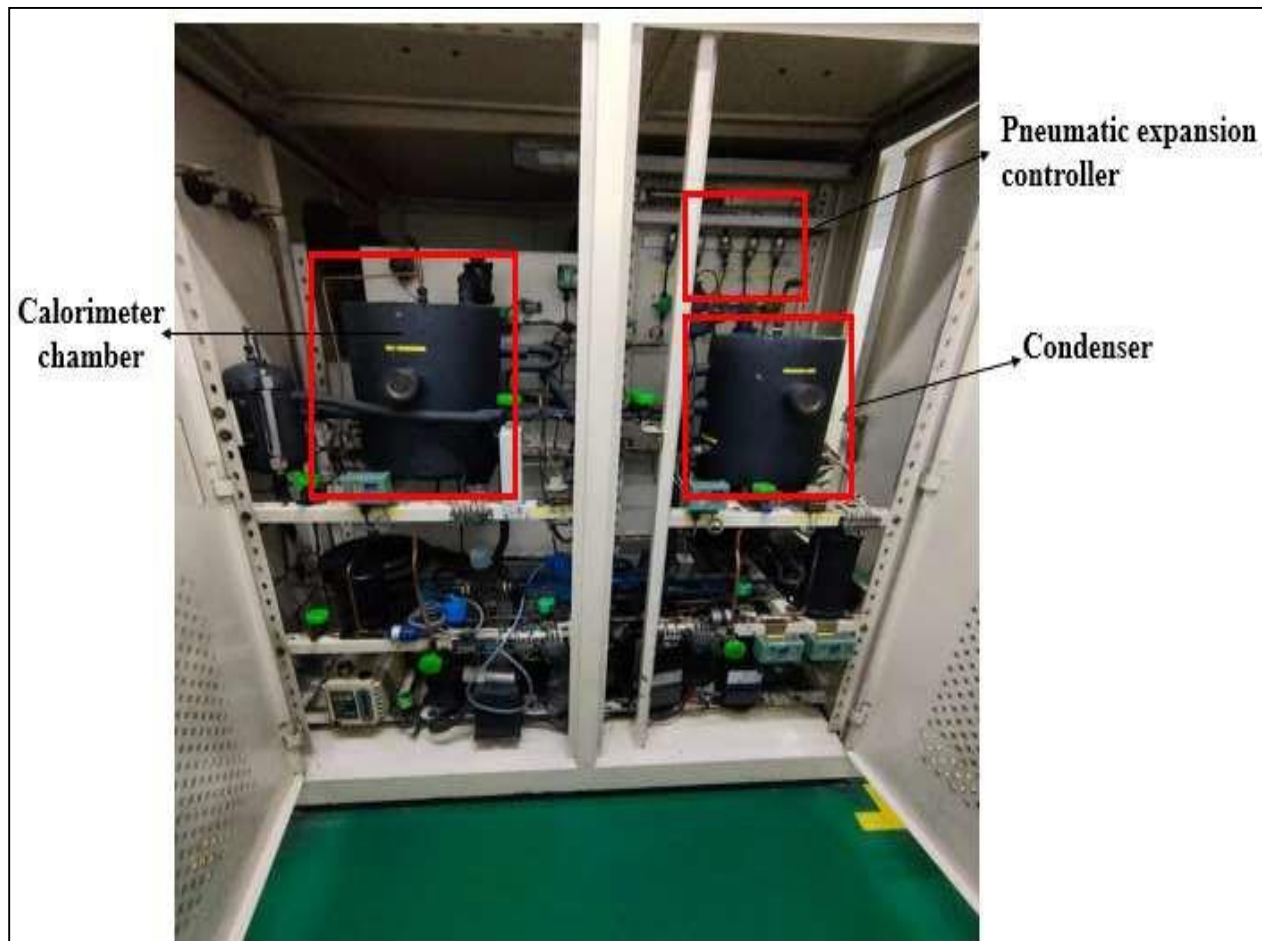

Fig. 18: Experimental Setup [LG. Electronics, India]

Calibration

- Heat given to the secondary fluid should be adjusted in such a way that a constant pressure is maintained corresponding to a saturation temperature that is approximately 15°C above the ambient air temperature.
- Ambient air temperature shall be maintained at a constant value error of $\pm 1^\circ\text{C}$ is allowed.
- If the heat input by the heater is continuous than it shall be maintained or can vary under the range of $\pm 1\%$ and in the interval of one hour, pressure of secondary fluid should be steady until four consecutive readings of corresponding temperature doesn't change within the error of $\pm 0.5^\circ\text{C}$.
- If the heat input is discontinuous then adjustment be done in such a way so that heat input shall be maintained or can vary within $\pm 0.5^\circ\text{C}$ and in the interval of a hour, pressure of secondary fluid should be measured until four readings of heat input doesn't change within the error of $\pm 4\%$.

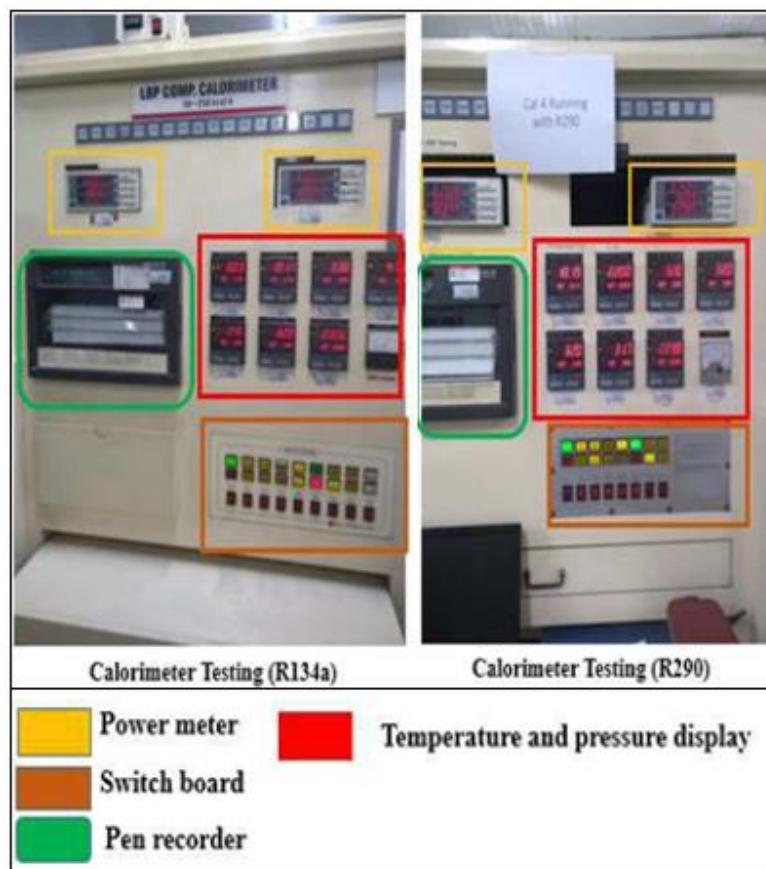

Fig. 19: Secondary fluid calorimeter testing chamber [LG electronics India]



Fig. 20: Vacuum process of Compressor [LG. Electronics, India]

Procedure

- Vacuum the compressor first, as nitrogen gas is present inside the compressor at the end of manufacturing of the compressor. So, that gas has to be removed before testing.
- Through the refrigerant expansion valve, the suction pressure of the compressor is adjusted.
- By varying the heat input to the secondary fluid, temperature of the refrigerant vapour entering in the compressor can be changed.
- By varying the flow and temperature of the condensing medium or a pressure control device shall be used in the discharge line to adjust the discharge pressure.

CHAPTER 4

RESULTS AND DISCUSSION

This chapter presented outcomes of this study which concludes experimental as well as theoretical analysis of performance of two reciprocating hermetic compressors containing R134a and R290. All the parameters of performance are discussed with the help of graphical representation which also helps in comparison between the refrigerants.

4.1 THEORETICAL ANALYSIS

A theoretical comparison of COP, mass flow rate, cooling capacity and power input between R134a and R290 is shown in this section. Also, in the theoretical analysis, thermo-physical properties of green refrigerants are compared with old used refrigerants used in the domestic refrigerators. Saturated properties like vapour pressure, liquid density, vapour density and latent heat are presented in the following plots against temperature. Temperature range is selected as per ASHRAE working range for VCRS cycle which is between -25°C to 55°C . R134a and R290 are compared on the basis of these properties so that performance variation can be determined. Both the refrigerants selected for this comparison are potential working fluids and R134a is considered in this study due to its performance which was pretty good back in days and it was used so widely in old refrigerator system. However, R134a's use is reducing now a days due to its harmful environmental effect. In this study REFPROP 7.0 is used for getting saturated properties of different refrigerants at mentioned temperature range.

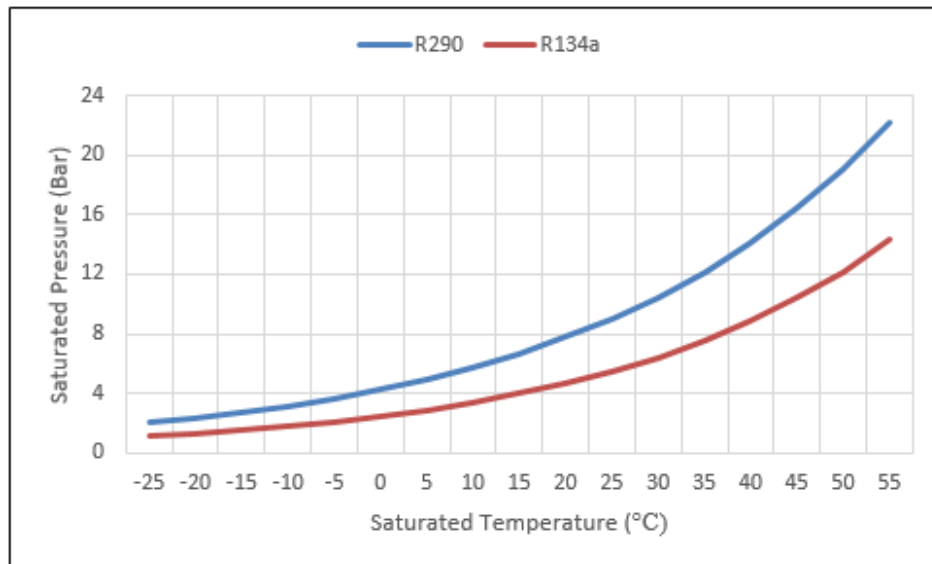

Fig. 21: Variation of saturated pressure with saturated temperature.

The plot in Fig.22, shows of saturated vapour pressure against temperature in which it can be observed that R290 has higher vapour pressure corresponding to same temperature range. This shows R290 demands for high pressure working system which means it require big size compressor to work. Where R134a has low pressure in evaporator side and high pressure in condenser side which means R134a has high pressure ratio which results higher compressor work.

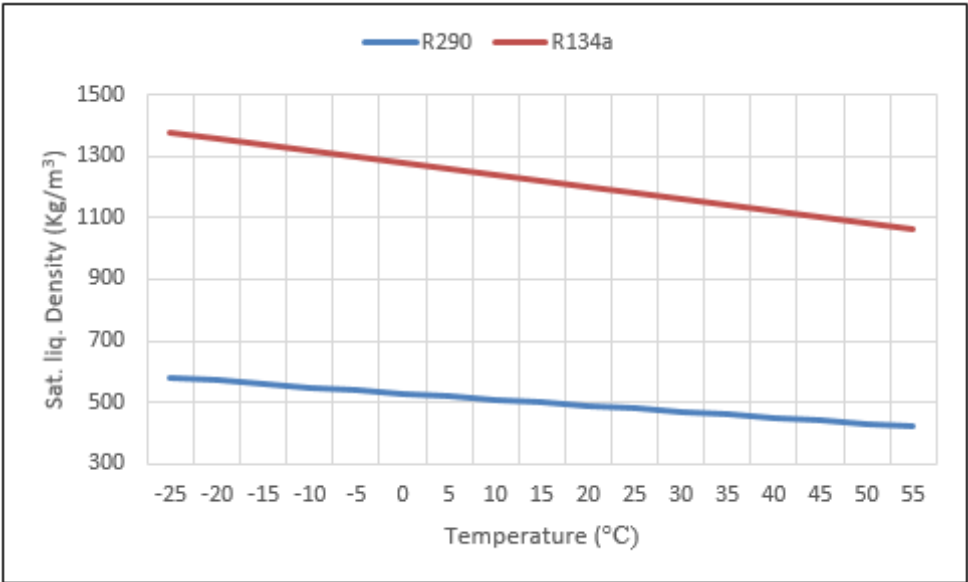

Fig. 22: Variation of saturated liquid density with temperature

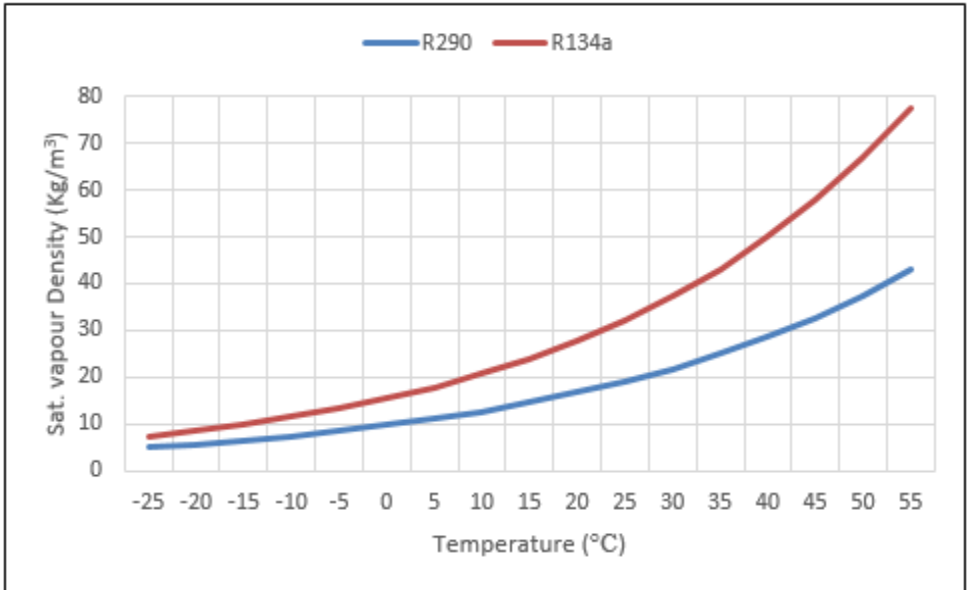

Fig. 23: Variation of saturated vapour density with temperature

Quantity of charge matters a lot in the performance of refrigerant in a refrigerator system. In above Fig. 23 shows the variation of saturated liquid density with temperature and Fig. 24 shows the variation of saturated vapour density with temperature. Generally in refrigerator system liquid refrigerant is more than vapour refrigerant. In both figures, it can be noticed that R134a has high density and higher density means higher mass flow rate. Having high mass flow rate will results in higher cooling capacity and higher compressor input power as well. Also, having higher density refrigerants in the system requires large and heavy built compressors. In Fig. 23 and Fig.24 it can be seen that R290 has low density in comparison to R134a, which means it will provide low cooling capacity and low compressor power input in comparison to R134a in same volumetric capacity of compressor.

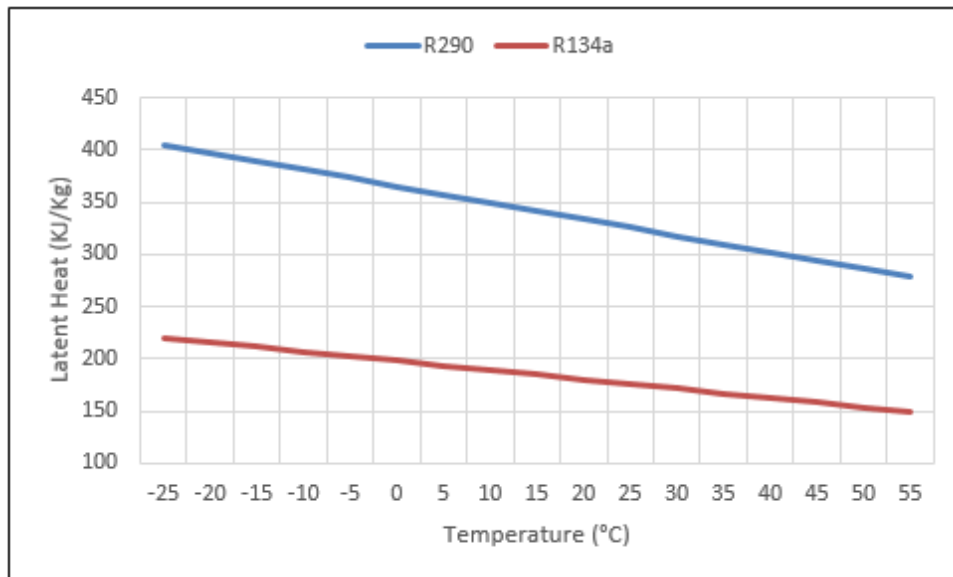

Fig. 24: Variation of latent heat with temperature

In Fig. 25 shows variation of latent heat of with temperature and it can be observed that R290 have high latent heat of evaporation and latent heat at condensation is low. R134a have least latent heat of vaporization and condensation. For attaining good performance, refrigerants must have high latent heat of vaporization and low latent heat of condensation. Fig.25, shows that R290 is best in refrigerant in case of latent heat parameter of performance.

With the help of numerical calculations and properties of refrigerants a comparison of performance parameters is done before the actual experimentation of the refrigerants in reciprocating hermetic compressor. In the given Table 7, parameters for performance comparison between refrigerants

R134a and R290 are mentioned in which volumetric displacement of cylinder of compressor is same for all the refrigerants.

Table 7: Theoretical comparison of performance parameters between R134a and R290.

Parameters	Unit	R134a	R290
Displacement	cm ³	6.9	6.9
RPM	Rev./min	3000	3000
Vapour Density at -23.3	kg/m ³	5.917	4.915
Mass Flow Rate	kg/s	0.002041	0.00170
Enthalpy Change in Vapourization	kJ/kg	185.4	354.4
Cooling Power	watts	378.478	600.889
Enthalpy Change in Compression	kJ/kg	121.2	223.6
Compressor Power	watt	247.419	379.116
COP		1.53	1.58

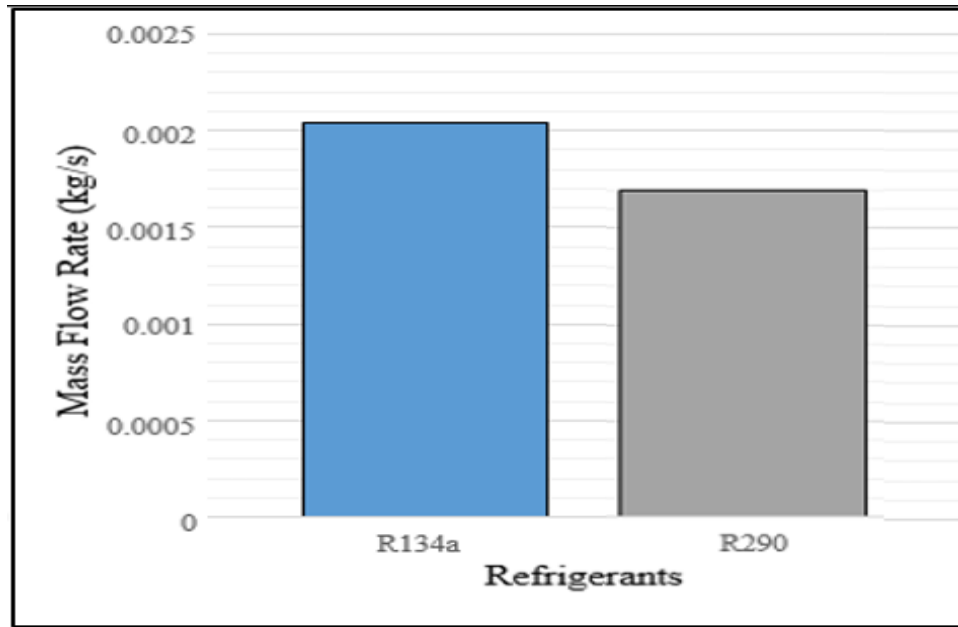

Fig. 25: Mass flow rate of refrigerants

In Fig. 26 showing the theoretical comparison of mass flow rate of mentioned two refrigerants. From the figure it can be seen R290 has low mass flow rate in comparison to R134a. This is because as it is clear from Fig. 23 and Fig.24 R290 has low liquid and vapour density while R134a is high density fluid.

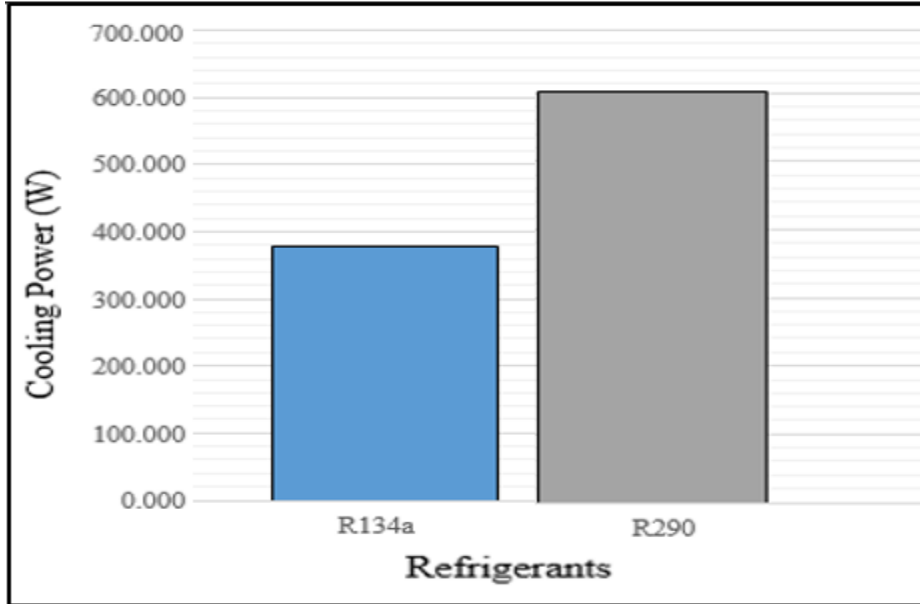

Fig. 26: Cooling power of refrigerants

In Fig. 27, showing the cooling power or cooling capacity of two mentioned refrigerants where R290 has high cooling capacity while R134a has low cooling capacity. However, it can be noticed from Table 7 that R290 has high enthalpy of vaporization while R134a has low enthalpy of vaporization. So, it concluded that mass flow rate is the main reason for such variation of cooling power as R290 has less mass flow rate than R134a.

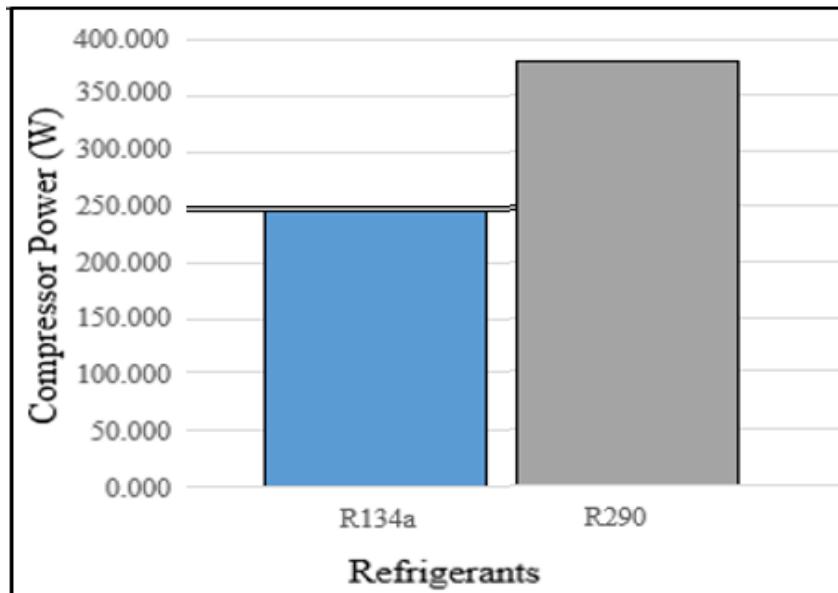

Fig. 27: Compressor power of Refrigerants

In Fig. 28, input compressor power is shown in which it can be observed that R290 will require high compressor power compared to R134a which will require less power input of compressor.

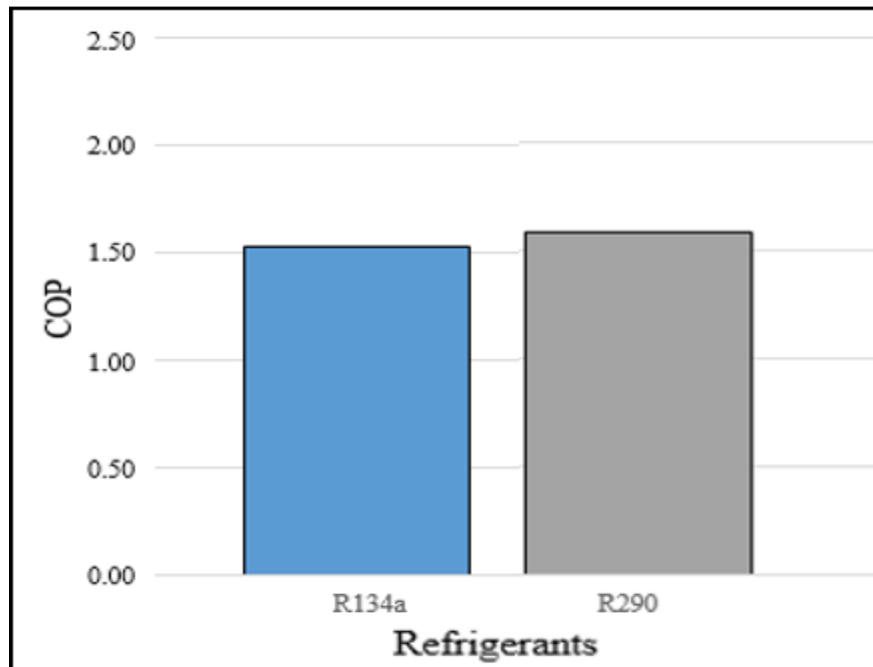

Fig. 28: COP of Refrigerants

In Fig. 29, comparison of COP of R134a and R290 is mentioned in which it is observed that COP of R290 is higher than R134a. So this can be concluded that R290 can be better alternative for R134a when it comes to overall performance.

From above theoretical analysis it can be concluded that R290 and R134a are compatible with heavier compressors. For higher cooling refrigerators R290 can be the alternate for R134a.

4.2 EXPERIMENTAL ANALYSIS

All experimental work is done in laboratory of LG electronics India Pvt. Ltd. Greater Noida. This experiment is performed on secondary fluid calorimeter and working procedure of calorimeter is same as mentioned in chapter 3. For this experimentation reciprocating hermetic compressors with induction motors is taken for the performance analysis. Six samples of the compressors is taken

for the experimentation with each refrigerant to conclude the accurate results in the end of the experimentation. R134a was the refrigerant initially used in reciprocating hermetic compressors with induction motors. Table 8 and Table 10 shows experimental data and results of calorimeter with refrigerant R134a and R290 respectively.

Table 8: Experimental results with R134a

Measurement Items	Units	Samples					
		1	2	3	4	5	6
Input Voltage	V	220	220	220	220	220	220
Frequency	Hz	60	60	60	60	60	60
Suction Pressure	kg/cm ²	1.173	1.173	1.173	1.173	1.173	1.173
Discharge Pressure	kg/cm ²	13.96	13.96	13.96	13.96	13.96	13.96
Current	A	1.28	1.27	1.27	1.25	1.27	1.3
Mass flow Rate	kg/s	0.001231	0.001225	0.001218	0.001208	0.001205	0.001222
Input Power	W	157	156.3	156.3	155.8	157.2	158.4
Cooling Capacity	Kcal/hr	196.4	195.5	194.4	192.7	192.3	194.9
EER	Btu/whr	4.97	4.97	4.94	4.91	4.86	4.88
COP		1.46	1.46	1.45	1.44	1.42	1.43
Suction Temp	°C	32	32	32	32	32	32
Discharge Temp	°C	96.45	94.89	94.73	95.72	96.8	95.32
Comp Surface Temp	°C	66.43	82.54	76.48	78.58	70.21	76.51
Calorimeter Outlet Temp	°C	32	32	32	32	32	32
Calo. Ambient Temp	°C	32	32	32	32	32	32
Exp Valve Inlet Temp	°C	32	32	32	32	32	32
Comp Ambient Temp	°C	32	32	32	32	32	32

Table 9: Experimental results with R290

Measurement Items	Units	Samples					
		1	2	3	4	5	6
Input Voltage	V	220	220	220	220	220	220
Frequency	Hz	50	50	50	50	50	50
Suction Pressure	kg/cm ²	1.0764	1.0764	1.0764	1.0764	1.0764	1.0764
Discharge Pressure	kg/cm ²	16.7164	16.7164	16.7164	16.7164	16.7164	16.7164
Current	A	1.65	1.64	1.64	1.64	1.65	1.64
Mass flow Rate	kg/s	0.00088	0.000892	0.000877	0.000884	0.000882	0.000891
Input Power	W	203.228	201.48	202.216	202.308	203.688	202.124
Cooling Capacity	Kcal/hr	270.572	274.252	269.652	271.86	271.216	274.068
EER	Btu/whr	5.28	5.4	5.29	5.33	5.29	5.38
COP		1.55	1.58	1.55	1.56	1.55	1.58
Suction Temp	°C	32.2	32.2	32.2	32.2	32.2	32.2
Discharge Temp	°C	120.1	122.2	120	120.5	120	122
Comp Surface Temp	°C	70.6	72.5	70	70.4	70	72
Calori meter Outlet Temp	°C	32.2	32.2	32.2	32.2	32.2	32.2
Calo. Ambient Temp	°C	32.2	32.2	32.2	32.2	32.2	32.2
Exp Valve Inlet Temp	°C	32.2	32.2	32.2	32.2	32.2	32.2
Comp Ambient Temp	°C	32.2	32.2	32.2	32.2	32.2	32.2

On the basis these experimental results following graphs are plotted and comparison between the mentioned refrigerants can be studied in this chapter.

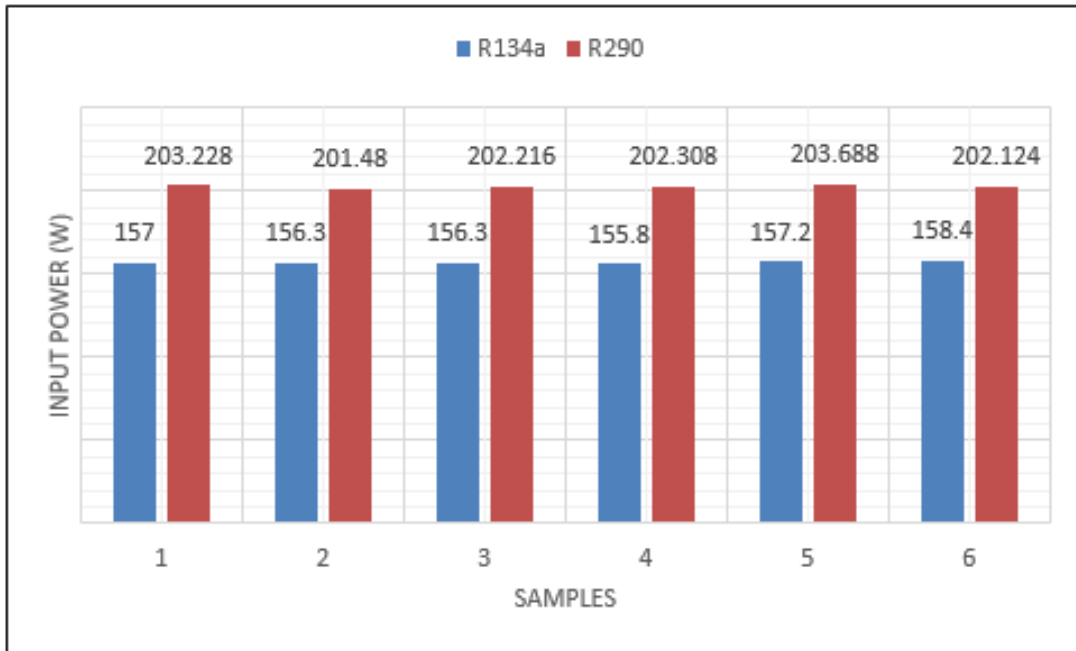

Fig. 29: Input power of Compressor's samples

In fig. 30, it can be observed that R290 has high power consumption as compared to R134a refrigerant and as per the results power consumption is 28 to 29% higher than R134a.

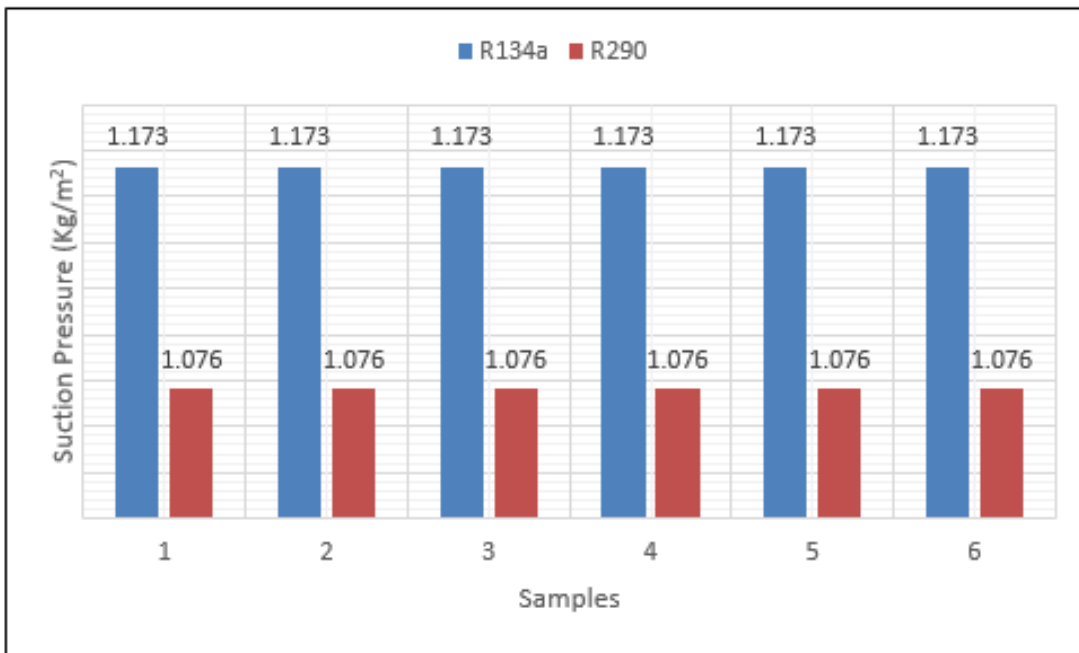

Fig. 30: Suction pressures of Compressor's samples

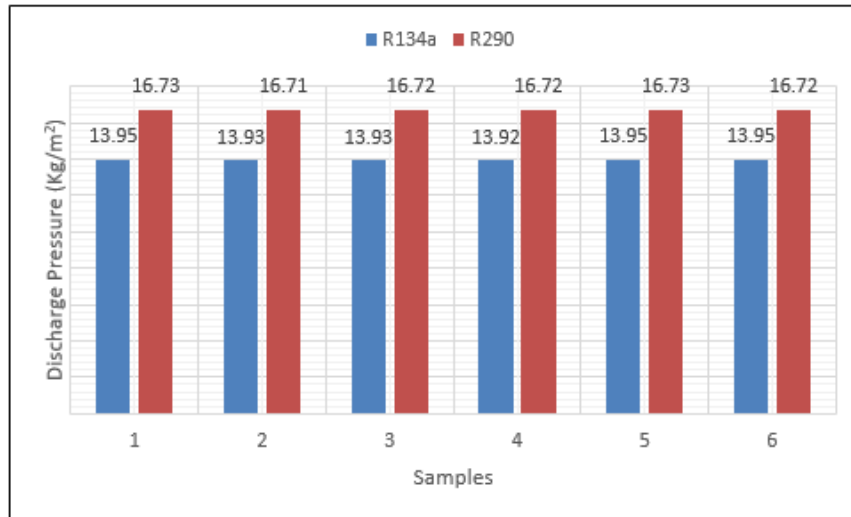

Fig. 31: Discharge pressures of Compressor's samples

Discharge and suction pressure range of the refrigeration system depends upon the saturated properties of the refrigerant. Power input of the compressor also depends upon the working pressures of vapour compression refrigeration system. Fig. 31 and Fig. 32, showing the suction and discharge pressure range of the refrigerant in the working refrigeration system. It can be seen suction pressure for R134a is 1.173 Kg/cm² which is high as compared to green refrigerant R290 and discharge pressure is 13.95 kg/cm² which is lower than R290. But R290 is working on larger suction to discharge pressure range. Suction pressure for R290 is 1.076 kg/cm² which lower than R134a and discharge pressure is high that is 16.73 kg/cm² shown in Fig. 31 and Fig. 32 respectively.

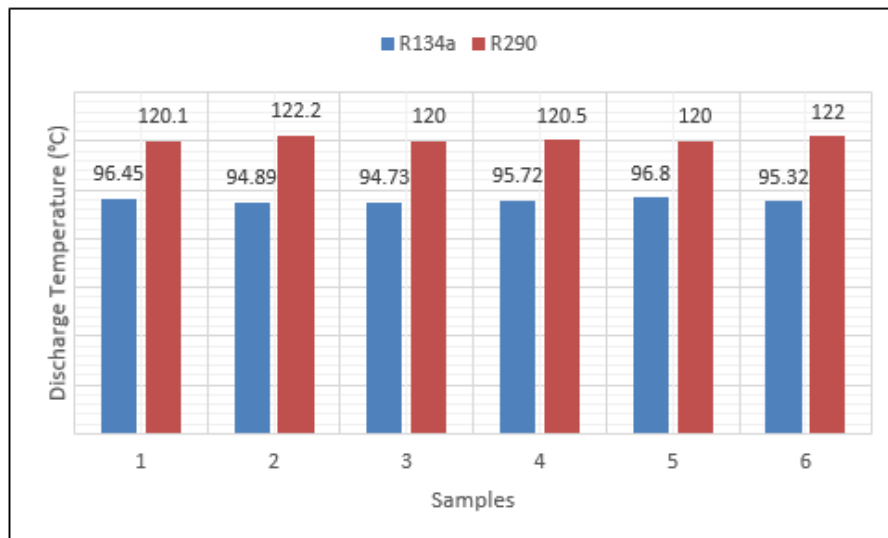

Fig. 32: Discharge temperatures of Compressor's samples.

Discharge temperature of the refrigerant is shown in Fig. 33, in which it can be observed that R134a has discharge temperature 94.73-96.45°C. Replacing R134a with R290 there is increment of 24-28.7% in discharge temperature. Higher discharge temperature will increase work in condenser of removing extra heat and also heating of compressor which lead to reduction in efficiency of compressors in various ways.

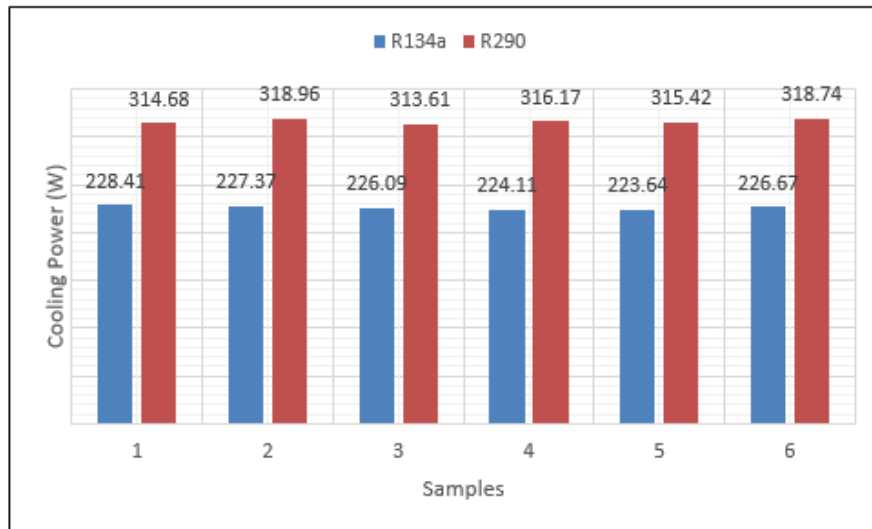

Fig. 33: Cooling Power of Compressor's sample

Fig. 34, showing the cooling power or cooling capacity of the refrigerants when they are used in secondary fluid calorimeter with hermetic compressors with induction motor. Cooling capacity of the system depends on two parameters that's mass flow rate and latent heat of vaporization. It can be seen that R290 has high cooling effect compared to R134a which is 27-28% lower than R290.

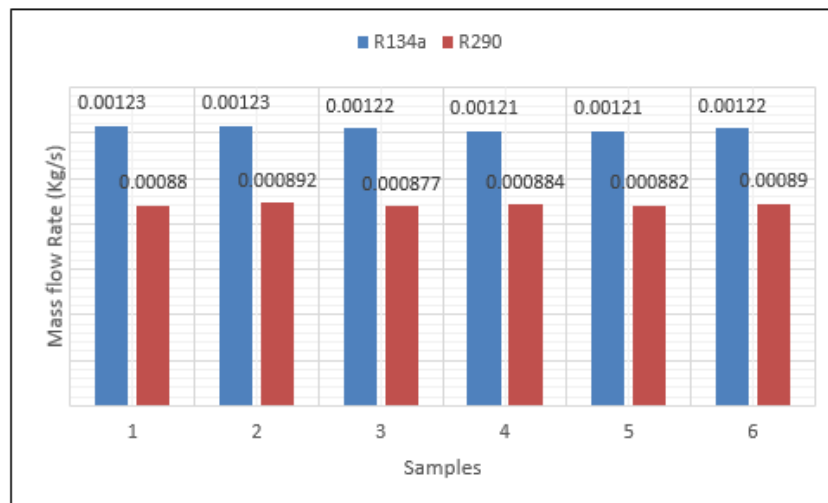

Fig. 34: Mass Flow Rate of refrigerants with Compressor's samples

Fig. 35, shows the mass flow rate of both refrigerants in calorimeter setup. Mass flow rate depends upon rate of piston displacement and density of refrigerant entering into the compressor. If pressure in suction line is high then density of refrigerant will be high and also density is property behavior of working fluid which can vary refrigerant to refrigerant. In Fig. 33 it can be noticed that R134a has high mass flow rate of 0.00123kg/s while R290 has mass flow rate of 0.00080 kg/s.

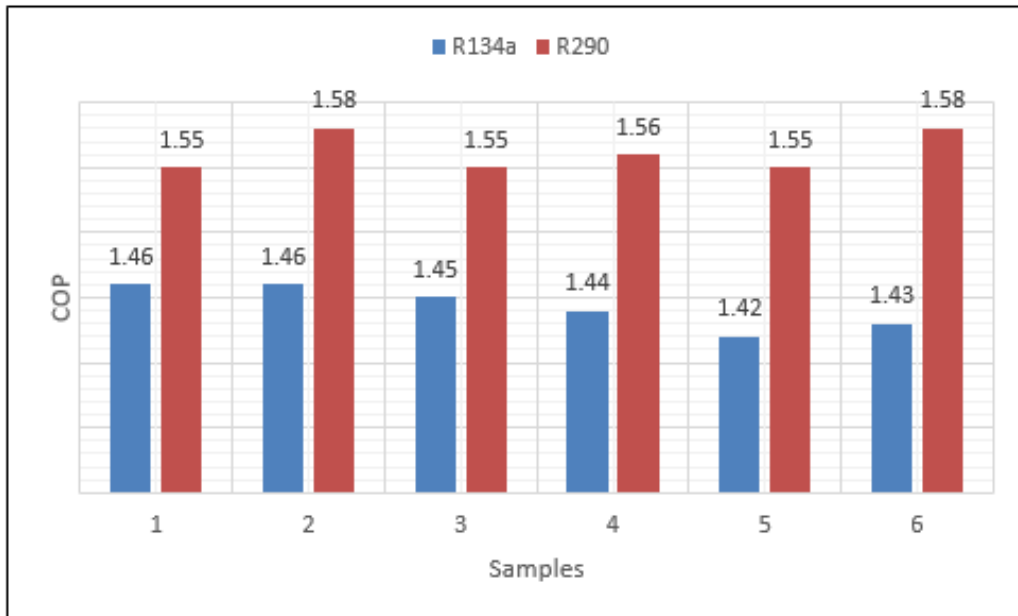

Fig. 35: COP of refrigeration system

COP of the refrigeration system with two refrigerants R134a and R290 is shown in Fig.36. From the figure it can be concluded that COP of R134a is lowest as compare to R290 refrigerant. R134a is primarily used refrigerant with single phase induction models of the reciprocating hermetic compressors which is used in domestic refrigerators. COP of R290 is 8-10% higher than COP of R134a.

CHAPTER 5

C

CONCLUSION AND FUTURE SCOPE

5.1 SUMMARY

In this study a numerical and experimental performance analysis is done with two refrigerants R134a and R290 on reciprocating hermetic compressors which are used in domestic refrigerators. Motivation behind the study is to find suitable alternate in place of R134a refrigerant in induction models of hermetic compressors which are used in domestic refrigerators. Secondary fluid calorimeter is used as experimental setup for this study and results are being compared to R134a which is primarily used refrigerant in compressors models having induction motors. This work is studied in two sections that is theoretical study and experimental study. In numerical study thermo-physical properties of respective refrigerants are studied and compared. Theoretical comparison of both refrigerants on the basis of performance key parameters like mass flow rate, cooling capacity, input compressor power, COP has been done. Experimental analysis is performed with the help of secondary fluid calorimeter as experimental setup. All the performance parameters are obtained through calorimeter having sensors and data analogs. Experimental results of calorimeter with two refrigerants R134a and R290 are compared with each other and various conclusions have been drawn on the basis of this whole study.

5.2 CONCLUSION

On the basis of above theoretical and experimental analysis following conclusions can be drawn:

1. Size of hermetic compressors used in refrigeration system depends upon the saturated pressure range of refrigerant corresponding to working temperatures in evaporator and condenser and also density of the refrigerant.
2. From the theoretical and experimental studies it can be seen that R134a is high density refrigerant as compared to R290. Therefore for the refrigeration system in which R134a is used as refrigerant required larger size compressors as compared to R290 and also, it works at high pressure range in evaporator and condenser. That's why induction models of reciprocating hermetic compressors used in refrigeration system are generally larger in size and weight and R134a is primary refrigerant used in these compressors.

3. In case of R290, despite of having low density it has low suction pressure corresponding to evaporator temperature and have high discharge pressure corresponding to condenser temperature. Due to these reasons with R290 as refrigerant compressor's power input is large as compared to R134a refrigerant.
4. Mass flow rate of refrigerants is another factor affecting compressor's input power and cooling capacity of refrigeration system. Due to low density refrigerant R290 has low mass flow rate and R134a has high density thus it has high mass flow rate for same volumetric capacity in reciprocating hermetic compressor.
5. From theoretical and experimental analysis it can be seen that R290 have high cooling capacity as compare to R134a.
6. From this study it can be seen that R290 has high COP while R134a which is primary refrigerant in induction models of reciprocating compressors have low COP and R134a have considerable GWP also which make a need to replace it with suitable alternate.

5.3 FUTURE SCOPE

In future it is sure R134a is going to be vanished because of its contribution towards global warming. Suitable alternates are present which can used and give better performance than R134a. Inverter models of reciprocating compressors used in domestic refrigerators, already worked on HCs refrigerants. In this study New Compressor model containing alternate HCs is being presented in induction models of hermetic compressors used in domestic compressors. There are some future scope and work that can be done in this field which is given as:

1. Investigation of alternates of HCs refrigerants like iso-butane (R600a), methane (R50), butane (R600), ethane (R170) and propylene (R1270) can be done for their performance analysis in refrigeration systems.
2. Also blends of HCs and HFCs refrigerants like R414, R407A, R407C and R410 can be tested in refrigeration system for better performance.
3. Apart from Induction model of reciprocating compressors, inverter models can be tested with same calorimeter setup for performance with different alternate refrigerants.
4. A study on the various losses like mechanical losses, thermal losses and electrical losses can be included for minimize them and attain better efficient refrigeration system.

REFERENCES

1. Harby, K. (2017). Hydrocarbons and their mixtures as alternatives to environmental unfriendly halogenated refrigerants: An updated overview. *Renewable and Sustainable Energy Reviews*, 73, 1247–1264.
2. Antunes, A. H. P., & Bandarra Filho, E. P. (2016). “Experimental investigation on the performance and global environmental impact of a refrigeration system retrofitted with alternative refrigerants”. *International Journal of Refrigeration*, 70, 119–127.
3. R.S. Khurmi, J.K. Gupta, “A textbook of refrigeration and air conditioning.” revised edition, S. Chand.
4. Nomenclature of Organic Chemistry: IUPAC Recommendations and Preferred Names 2013 (Blue Book). Cambridge: The Royal Society of Chemistry. 2014. p. 652
5. Refrigerant types - SWEP. (2019). swep.net. <https://www.swep.net/refrigerant-handbook/5.-refrigerants/sd4>.
6. Global Warming Potentials of ODS Substitutes Ozone Layer Protection US EPA. Epa.gov (28 June 2006).
7. 2009 ASHRAE HANDBOOK – Fundamentals, Chapter 29: Refrigerants, ASHRAE, Atlanta GA, 2009
8. Reciprocating compressors (2017). learnmech.com. <https://learnmech.com/reciprocating-compressor-parts-diagram-basic-working>
9. Bill Forsthoffer, W. E. (2005). “Compressor types and applications”. Forsthoffer’s Rotating Equipment Handbooks, 13–27.
10. Robison, David H.; Beaty, Peter J. (1992). Compressor Types, Classifications, and Applications. “Texas A&M University. Turbo machinery Laboratories”, pg. 183-188.
11. Sharad Chaudhary, Deepak Gupta, (2013) “Performance Analysis of Reciprocating Refrigerant Compressor”, *International Journal of Science and Research (IJSR)*, Volume 2 Issue 6, 230 – 235.
12. Douglas, J., Braun, J., Groll, E., & Tree, D. (1999). “A cost-based method for comparing alternative refrigerants applied to R-22 systems”. *International Journal of Refrigeration*, 22(2), 107-125.
13. Palm, B. (2007). “Refrigeration systems with minimum charge of refrigerant”. *Applied Thermal Engineering*, 27(10), 1693-1701.

14. Dalkilic, A., & Wongwises, S. (2010). "A performance comparison of vapor-compression refrigeration system using various alternative refrigerants". *International Communications in Heat and Mass Transfer*, 37(9), 1340-1349.
15. Bolaji, B. O., & Huan, Z. (2012). "Comparative analysis of the performance of hydrocarbon refrigerants with R22 in a sub-cooling heat exchanger refrigeration system". *Proceedings of the Institution of Mechanical Engineers, Part A: Journal of Power and Energy*, 226(7), 882-891.
16. Subiantoro, A., Ooi, K., & Junaidi, A. (2013). "Performance and suitability comparisons of some R22 possible substitute refrigerants". *8th International Conference on Compressors and Their Systems*, 67-76.
17. Ravi kumar, T., & Lal, D. M. (2009). "On-road performance analysis of R134a/R600a/R290 refrigerant mixture in an automobile air-conditioning system with mineral oil as lubricant". *Energy Conversion and Management*, 50(8), 1891-1901.
18. Rahul P Patel, Dr. R. G. Kapadia. (2013), "Performance Evaluation of a Vapor Compression Refrigeration System for Simultaneous Cooling and Heating by Using R22 and Alternative Refrigerants", *International journal of engineering research & technology (IJERT) Volume 02*.
19. Dhamneya, A. K., Rajput, S. P. S., & Singh, A. (2018). "Comparative performance analysis of ice plant test rig with TiO₂-R-134a nano refrigerant and evaporative cooled condenser". *Case Studies in Thermal Engineering*, 11, 55–61.
20. Nair, V., Parekh, A., & Tailor, P. (2020). "Experimental investigation of a vapour compression refrigeration system using R134a/Nano-oil mixture". *International Journal of Refrigeration*, 112, 21–36.
21. Gill, J., & Singh, J. (2017). "Energy analysis of vapor compression refrigeration system using mixture of R134a and LPG as refrigerant". *International Journal of Refrigeration*, 84, 287–299.
22. Yogesh Joshi, Dinesh Zanwar, & Sandeep Joshi. (2021). "Performance investigation of vapor compression refrigeration system using R134a and R600a refrigerants and Al₂O₃ nanoparticle based suspension". *Materials Today: Proceedings*, 44, 1511–1519.
23. Cabello, R., Torrella, E., & Navarro-Esbri, J. (2004). "Experimental evaluation of a vapour compression plant performance using R134a, R407C and R22 as working fluids". *Applied Thermal Engineering*, 24(13), 1905-1917.

24. Wongwises, S., & Chimres, N. (2005). "Experimental study of hydrocarbon mixtures to replace HFC-134a in a domestic refrigerator". *Energy Conversion and Management*, 46(1), 85-100.
25. Fatouh, M., & Kafafy, M. E. (2006). "Experimental evaluation of a domestic refrigerator working with LPG". *Applied Thermal Engineering*, 26(14-15), 1593-1603.
26. Rocca, V. La, & Panno, G. (2011). "Experimental performance evaluation of a vapour compression refrigerating plant when replacing R22 with alternative refrigerants". *Applied Energy*, 88(8), 2809–2815.
27. Olatunbosun, B. E., & Borokinni, F. O. (2018). "Comparative Analysis of Performance of R600a and R510a Refrigerants in a Retrofitted Refrigerating System". *Proceedings of Engineering and Technology Innovation*, 8, 32-39.
28. Nawaz, K., Shen, B., Elatar, A., Baxter, V., & Abdelaziz, O. (2017). "R290 (propane) and R600a (isobutane) as natural refrigerants for residential heat pump water heaters". *Applied Thermal Engineering*, 127, 870-883.
29. Ariyo, D., Azeez, M., & Woli, T. (2017). "Comparison of Cooling Parameters of R134a and R290/R600a". *IOSR Journal of Mechanical and Civil Engineering*, 14(03), 87-90.
30. Belman-Flores, J. M., Rodríguez-Muñoz, A. P., Pérez-Reguera, C. G., & Mota-Babiloni, A. (2017). "Experimental study of R1234yf as a drop-in replacement for R134a in a domestic refrigerator". *International Journal of Refrigeration*, 81, 1–11.
31. Ma, Z., Liu, F., Tian, C., Jia, L., & Wu, W. (2021). "Experimental comparisons on a gas engine heat pump using R134a and low-GWP refrigerant R152a". *International Journal of Refrigeration*, 115, 73–82.
32. Chen, X., Liang, K., Li, Z., Zhao, Y., Xu, J., & Jiang, H. (2020). Experimental assessment of alternative low global warming potential refrigerants for automotive air conditioners application. *Case Studies in Thermal Engineering*, 22, 100800.
33. Sánchez, D., Cabello, R., Llopis, R., Arauzo, I., Catalán-Gil, J., & Torrella, E. (2017). Energy performance evaluation of R1234yf, R1234ze (E), R600a, R290 and R152a as low-GWP R134a alternatives. *International Journal of Refrigeration*, 74, 269–282.
34. Makhnatch, P., Mota-Babiloni, A., & Khodabandeh, R. (2017). "Experimental study of R450A drop-in performance in an R134a small capacity refrigeration unit". *International Journal of Refrigeration*, 84, 26–35.
35. Prall John & Martin D., (2013). *Compressors*. RSES, 12–16.

https://www.rses.org/asssts/rses_journal/0813_Compressors.pdf

36. Arora, C. P. (2014). "Refrigeration & Air Conditioning (3rd ed.)". MC GRAW HILL INDIA.
37. Hermetic Compressor. (2015). Nptel.ac, <https://nptel.ac.in/content/storage2/courses/112105129/R&AC%20Web%20files/R&AC%20Lecture%202/Hyperlinks/Hermetic%20compressors.htm>
38. http://lib.unipune.ac.in:8080/jspui/bitstream/123456789/6995/14/14_chapter%203.pdf

MTEhch_Thesis

ORIGINALITY REPORT

15%	11%	11%	0%
SIMILARITY INDEX	INTERNET SOURCES	PUBLICATIONS	STUDENT PAPERS

S. G. Kost

Prabhjör