

# PERFORMANCE ANALYSIS OF FOUR WAVE MIXING EFFECT IN WDM SYSTEMS

*Thesis submitted in the partial fulfillment of requirements  
for the award of the degree of*

*MASTER OF ENGINEERING (M.E)*

*In*

**ELECTRONICS AND COMMUNICATION ENGINEERING**

*Submitted by*

**MONIKA**

**800861025**

Under the esteemed guidance of

**Dr. R S Kaler**  
**Professor**  
**E.C.E.D, T.U**



Department of Electronics & Communication Engineering,  
Thapar University,  
Patiala-147004, Punjab, India  
June, 2010

## DECLARATION

I, hereby, declare that the thesis report entitled "**Performance analysis of four wave mixing effect in WDM systems**" is an authentic record of my study carried out as requirements for the award of degree of M.E. (Master of Engineering) in Electronics and Communication Engineering Department, Thapar University, Patiala, under the guidance of Dr. R.S Kaler during January to June, 2010.

The matter presented in this report has not been submitted in any other University or Institute for the award of any degree.

*Monika*  
(Monika)

Signature of student

Dated: 30-06-2010

This is certified that the above statement made by the student is correct to the best of my knowledge and belief.

*R.S. Kaler*

(Dr. R.S. Kaler)

Professor, E.C.E.D

Date: \_\_\_\_\_

Countersigned By:

*A.K. Chatterjee*

(Dr. A. K. Chatterjee)

Head of Department, E.C.E.D

Thapar University, Patiala

Date: 15.7.10

*R.K. Sharma*  
16.7.10

(Dr. R. K. Sharma)

Dean, Academic Affairs

Thapar University, Patiala

Date: \_\_\_\_\_

# ACKNOWLEDGEMENT

First of all I would like to thank the Almighty, who has always guided me to work on the right path of the life. My greatest thanks are to my mother who bestowed ability and strengthen me to complete this work. I am deeply indebted to my relatives and friends for their inspiration and ever encouraging moral support, which enabled me to pursue my studies.

This work would not have been possible without the encouragement and able guidance of my supervisor **Dr. R.S Kaler**. His enthusiasm and optimism made this experience rewarding and enjoyable. Most of the study in this report is the result of our numerous stimulating discussions. His feedback and editorial comments were also valuable for writing this report.

I am very thankful to the Head of the Department, **Dr. A.K. Chatterjee**, for his encouragement, support and for providing the facilities for the completion of this report.

I am also very thankful to the entire faculty and staff members of Electronics and Communication Department for their direct–indirect help, cooperation, and affection.

**Monika**

**800861025**

# ABSTRACT

The nonlinear effects degrade the system performance. Because nonlinear effects tend to manifest themselves when optical power is very high, they become important in DWDM. Four-wave mixing (FWM) is one of the dominating degradation effects in wavelength-division-multiplexing (WDM) systems with dense channel spacing and low chromatic dispersion on the fiber. If in a WDM system the channels are equally spaced, the new waves generated by FWM will fall at channel frequencies and, thus, will give rise to crosstalk. Four-wave mixing (FWM) is a parametric process in which different frequencies interact and by frequency mixing generate new spectral components.

The four wave mixing effect on bit error rate, Q-factor, output spectrums and eye diagrams at different channel spacing is investigated. The design, implementation and performance analysis of four wave mixing in optical communication system for different values of spacing between input channels has been done. The comparison of four wave mixing effect at various values of channel spacing revealed that 75 GHz spacing has the edge over 6.25 GHz spacing in optical communication system. According to the results, spacing of 75 GHz has the lowest BER and better system performance. Hence, the higher spacing values between the input channels is recommended for long distance transmission without four wave mixing. The graphs of BER, Q-factor and eye opening show that higher channel spacing gives the best performance as compared to lower channel spacing. Hence, it is concluded that higher channel spacing is best suitable to be employed in the optical communication systems. But much higher channel spacing is blocked by bandwidth constraints so channel spacing must be optimized.

The design and performance analysis of four wave mixing effect on changing various components in the system is also presented. Components involve different data sources like pn-sequence generator with different bit rate; modulator drivers like NRZ and RZ raised cosine, NRZ and RZ rectangular, RZ supergaussian, RZ soliton; modulators like linear amplitude, linear electroabsorption and optical phase modulator; laser with different power values. The extent of four wave mixing is considered for each and every component separately. The comparison of four wave mixing with different components revealed that changing the bit rate of data source doesn't affect the four wave mixing at the output. Changing the modulator drivers least affects the four wave mixing. It is observed that NRZ raised cosine modulator driver gives the least four wave mixing. On changing the modulator, the four wave mixing is largely effected. The linear amplitude modulator gives the best system performance and the optical phase

modulator gives the worst performance among all the modulators. Hence, it is concluded that linear amplitude modulator is best suitable to be employed in the optical communication system minimizing the four wave mixing effect. The simulation results revealed that NRZ raised cosine modulator driver and linear amplitude modulator gives the best performance in terms of four wave mixing in optical communication system. Also, the eye opening and the Q-factor increases on increasing the laser power. Moreover, the bit error rate is minimum when the power level of laser is maximum.

The investigation of four wave mixing effect with different number of channels at various channel spacings has also been done. All the input channels are spaced evenly at various values like 6.25 GHz, 12.5 GHz, 25 GHz, 40 GHz, 50 GHz with the different number of channels at the input i.e. with 2, 4, 6, 8, 12 input channels. Analyzing the effect of four wave mixing for each channel spacing with these number of channels in terms of eye diagrams, BER, eye opening and Q-factor, it has been observed that on increasing the number of input channels/users, the interference increases and thus, the four wave mixing effect also increases. The eye opening decreases as the number of channels increases. Increasing the number of channels causes the Q-factor to decrease. Moreover, as the number of channels increases, the BER also increases. The simulation results revealed that the less number of users at input cause less four wave mixing but in today's technology, it is important for the circuit to handle wavelength division multiplexing.

Thus, the thesis presents the design and performance analysis of four wave mixing effect on bit error rate, Q-factor, output spectrums and eye opening with varying parameters.

# TABLE OF CONTENTS

---

<b>DECLARATION</b>	<b>i</b>
<b>ACKNOWLEDGEMENT</b>	<b>ii</b>
<b>ABSTRACT</b>	<b>iii</b>
<b>TABLE OF CONTENTS</b>	<b>v</b>
<b>LIST OF FIGURES</b>	<b>vii</b>
<b>ABBREVIATIONS</b>	<b>x</b>

---

## **CHAPTER 1: INTRODUCTION** **1-7**

1.1	Introduction to optical communication	1
1.2	Multiplexing	2
	1.2.1 Types of multiplexing techniques	2
	(a) TDM	2
	(b) WDM	2
1.3	Introduction to fiber nonlinear effects	3
1.4	Introduction to four wave mixing	4
1.5	Applications of FWM	7

## **CHAPTER 2: LITERATURE REVIEW** **8-14**

2.1	Literature survey	8
2.2	Motivation	12
2.3	Objectives of thesis	13
2.4	Organization of thesis	14

## **CHAPTER 3: INVESTIGATION OF FOUR WAVE MIXING EFFECT** **15-29**

### **ON BER, Q-FACTOR AND EYE OPENING AT ULTRA LOW**

#### **CHANNEL SPACING**

3.1	Introduction	15
3.2	Schematic model	17

3.3	Simulation setup	18
3.4	Results and discussion	21
3.5	Conclusion	29

**CHAPTER 4: DESIGN AND PERFORMANCE ANALYSIS OF FOUR      30-45**

**WAVE MIXING EFFECT DIFFERENT OPTICAL TRANSMITTER COMPONENTS**

4.1	Introduction	30
4.2	Schematic model	33
4.3	Simulation setup	34
4.4	Results and discussion	36
4.4.1	Effect of changing bit rate of data source	36
4.4.2	Effect of changing modulator drivers	37
4.4.3	Effect of changing modulators	39
4.4.4	Effect of changing power of Continuous Wave Lasers	41
4.5	Conclusion	44

**CHAPTER 5: INVESTIGATION OF FWM EFFECT WITH DIFFERENT      46-63**

**NUMBER OF INPUT CHANNELS AT VARIOUS CHANNEL SPACINGS**

5.1	Introduction	46
5.2	Schematic model	49
5.3	Simulation setup	50
5.4	Results and discussion	52
5.5	Conclusion	62

**CHAPTER 6: CONCLUSION AND FUTURE SCOPE      64-65**

6.1	Conclusion	64
6.2	Future scope	65

**REFERENCES      66-72**

# LIST OF FIGURES

---

Figure 1.1	TDM	2
Figure 1.2	WDM system	3
Figure 1.3	Schematic of four wave mixing in frequency domain	6
Figure 3.1	Schematic model	18
Figure 3.2	Simulation setup	20
Figure 3.3	Input optical spectrum used for analyzing FWM effect	21
Figure 3.4	(a) Output spectrum for 6.25 GHz spacing	22
	(b) Output spectrum for 10 GHz spacing	23
	(c) Output spectrum for 20 GHz spacing	23
	(d) Output spectrum for 25 GHz spacing	24
	(e) Output spectrum for 75 GHz spacing	24
Figure 3.5	Variation of BER with respect to Channel spacing	25
Figure 3.6	Variation of Q-factor with respect to Channel spacing	26
Figure 3.7	Variation of Eye opening with respect to Channel spacing	26
Figure 3.8	(a) Eye diagram for 6.25 GHz spacing	27
	(b) Eye diagram for 10 GHz spacing	28
	(c) Eye diagram for 20 GHz spacing	28
	(d) Eye diagram for 75 GHz spacing	29
Figure 4.1	Schematic model	34
Figure 4.2	Simulation setup	35

Figure 4.3	(a) Bit rate 10 Gbps	36
	(b) Bit rate 20 Gbps	37
Figure 4.4	(a) Output spectrum of NRZ rectangular modulator driver	38
	(b) Output spectrum of RZ rectangular modulator driver	38
	(c) Output spectrum of RZ raised cosine modulator driver	38
	(d) Output spectrum of RZ super gaussian modulator driver	38
	(e) Output spectrum of RZ soliton modulator driver	39
Figure 4.5	(a) Output spectrum for linear amplitude modulator	40
	(b) Output spectrum for linear electroabsorption modulator	40
	(c) Output spectrum for optical phase modulator	40
Figure 4.6	(a) Eye diagram for power of -10 dB	41
	(b) Eye diagram for power of -5 dB	41
	(c) Eye diagram for power of 0 dB	42
	(d) Eye diagram for power of 5 dB	42
	(e) Eye diagram for power of 10 dB	42
Figure 4.7	Variation of Eye opening with respect to laser power	43
Figure 4.8	Variation of Q-factor with respect to laser power	43
Figure 4.9	Variation of BER with respect to laser power	44
Figure 5.1	Schematic model	49
Figure 5.2	Simulation setup	51
Figure 5.3	(a) Eye diagram for 6.25 GHz channel spacing with 2 input channels	52
	(b) Eye diagram for 6.25 GHz channel spacing with 4 input channels	53

	(c) Eye diagram for 6.25 GHz channel spacing with 6 input channels	53
	(d) Eye diagram for 6.25 GHz channel spacing with 8 input channels	53
	(e) Eye diagram for 6.25 GHz channel spacing with 12 input channels	53
Figure 5.4	(a) Eye diagram for 12.5 GHz channel spacing with 2 input channels	54
	(b) Eye diagram for 12.5 GHz channel spacing with 4 input channels	54
	(c) Eye diagram for 12.5 GHz channel spacing with 6 input channels	54
	(d) Eye diagram for 12.5 GHz channel spacing with 8 input channels	55
	(e) Eye diagram for 12.5 GHz channel spacing with 12 input channels	55
Figure 5.5	(a) Eye diagram for 25 GHz channel spacing with 2 input channels	55
	(b) Eye diagram for 25 GHz channel spacing with 4 input channels	55
	(c) Eye diagram for 25 GHz channel spacing with 6 input channels	56
	(d) Eye diagram for 25 GHz channel spacing with 8 input channels	56
	(e) Eye diagram for 25 GHz channel spacing with 12 input channels	56
Figure 5.6	(a) Eye diagram for 40 GHz channel spacing with 2 input channels	57
	(b) Eye diagram for 40 GHz channel spacing with 4 input channels	57
	(c) Eye diagram for 40 GHz channel spacing with 6 input channels	57
	(d) Eye diagram for 40 GHz channel spacing with 8 input channels	58
	(e) Eye diagram for 40 GHz channel spacing with 12 input channels	58
Figure 5.7	(a) Eye diagram for 50 GHz channel spacing with 2 input channels	58
	(b) Eye diagram for 50 GHz channel spacing with 4 input channels	58
	(c) Eye diagram for 50 GHz channel spacing with 6 input channels	59
	(d) Eye diagram for 50 GHz channel spacing with 8 input channels	59

	(e) Eye diagram for 50 GHz channel spacing with 12 input channels	59
Figure 5.8	Variation of Eye opening with respect to number of channels	60
Figure 5.9	Variation of Q-factor with respect to number of channels	61
Figure 5.10	Variation of BER with respect to number of channels	62

# ABBREVIATIONS

WDM	Wavelength Division Multiplexing
FWM	Four Wave Mixing
LAN	Local Area Network
TDM	Time Division Multiplexing
FDM	Frequency Division Multiplexing
DWDM	Dense Wavelength Division Multiplexing
SPM	Self Phase Modulation
XPM	Cross Phase Modulation
SRS	Stimulated Raman Scattering
SBS	Stimulated Brillouin Scattering
BER	Bit Error Rate
Q-factor	Quality Factor
PSO	Pseudo Orthogonal
MAN	Metropolitan Area Network
CS-RZ	Carrier-Suppressed Return-to-Zero
DPSK	Differential Phase-Shift Keying
SMF	Single Mode Fiber
PMD	Polarization Mode Dispersion
SOA	Semiconductor Optical Amplifier
LED	Light Emitting Diode
ITU-T	International Telecommunication Union-Telecommunication
NRZ	Non Return-to-Zero
RZ	Return-to-Zero

# CHAPTER 1

## INTRODUCTION

---

### 1.1 INTRODUCTION TO OPTICAL COMMUNICATION

Since the mid 90's, optical fibers have been used for point to point communication at a very high speed. Fiber-optic communication is a method of transmitting information from one place to another by sending light through an optical fiber. Fiber-optic communication systems have revolutionized the telecommunications industry and played a major role in the advent of the information age. Often the optical fiber offers much higher speed than the speed of electronic signal processing at both ends of the fiber. Because of its advantages over electrical transmission, the use of optical fiber has largely replaced copper wire communications in the developed world. The main benefits of fiber are its exceptionally low loss, allowing long distances between amplifiers or repeaters and its inherently high data-carrying capacity, such that thousands of electrical links would be required to replace a single high bandwidth fiber. Another benefit of fiber is that even when run alongside each other for long distances, fiber cables experience effectively no crosstalk, in contrast to some types of electrical transmission lines. The main advantages of the optical fiber communications are the high speed, large capacity and high reliability by the use of the broadband of the optical fiber. The huge bandwidth of optical fiber communication system can be utilized to its maximum by using multiple access techniques.

So to be able to take the full advantage of the speed in optical fibers one of the basics concepts in fiber optic communication is the idea of allowing several users to transmit data simultaneously over the communication channel by simultaneously allocating the available bandwidth to each user. This is called multiple access. There are two types of multiple access techniques: Asynchronous and Synchronous. Asynchronous multiple access methods, where network access is random and collisions occur are well suited to LAN's with low traffic demand [1]. However, these asynchronous access methods suffer from cumulative delay as the traffic intensity increases. On the other hand, synchronous accessing methods, where transmissions are perfectly scheduled provide more successful transmissions than asynchronous methods [2].

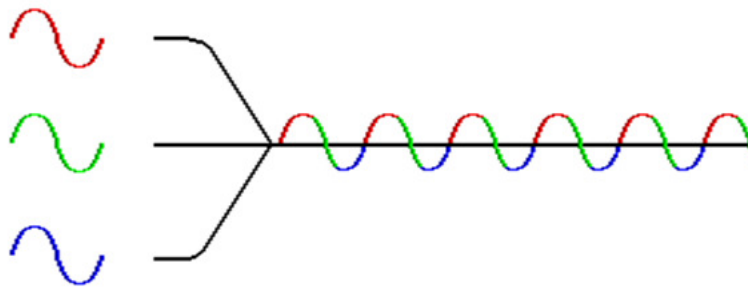
## 1.2 MULTIPLEXING

Since the first wires were laid for telegraphs in the 1800's, the drive has been to increase the amount of information that can be sent in a given interval. In the early years of telegraphs, telephones, and other telecommunications, the simple and obvious solution was to add more lines of communication. The increased cost of wire-laying and maintenance quickly built up, however, and a new answer to the problem had to be invented. The answer was multiplexing, in which more than one signal is sent over the same line [3].

### 1.2.1 Types of multiplexing techniques

The commonly used multiplexing techniques are TDM and WDM.

- (a) **TDM:** Time division multiplexing (TDM) is the least efficient form of multiplexing. In TDM, multiple signals are transferred, but each one is sent in parts, as seen in the figure below:



**Figure 1.1:** TDM

It is clear in the figure that two thirds of each signal is lost due to the division of time that gives TDM its name. This form of multiplexing is uneconomical for digital information transfers, as much of the signal from each source is lost. If the number of users on a line is high, or if there are about the same number of users on a line at all times, a new multiplexing scheme should be used [3].

- (b) **WDM:** Since wavelength and frequency are closely related to each other, this form of multiplexing is often called frequency division multiplexing (FDM). Each WDM fiber has a certain bandwidth—the range of frequencies it can carry. One advantage of WDM is that every user can transmit information at the highest rate possible all the time. WDM does not change

transfer rates in proportion to the number of users on the line. Another large benefit to WDM is that it increases the amount of information that can be transferred without significant loss of signal integrity. In any two fibers of the same quality, one signal will be lost just as fast as ten or more, so there is nothing to be lost—and much to be gained—from WDM. Even with the new solution to the bandwidth bottleneck, the ground gained by WDM was lost quickly, and another step forward had to be made [3].

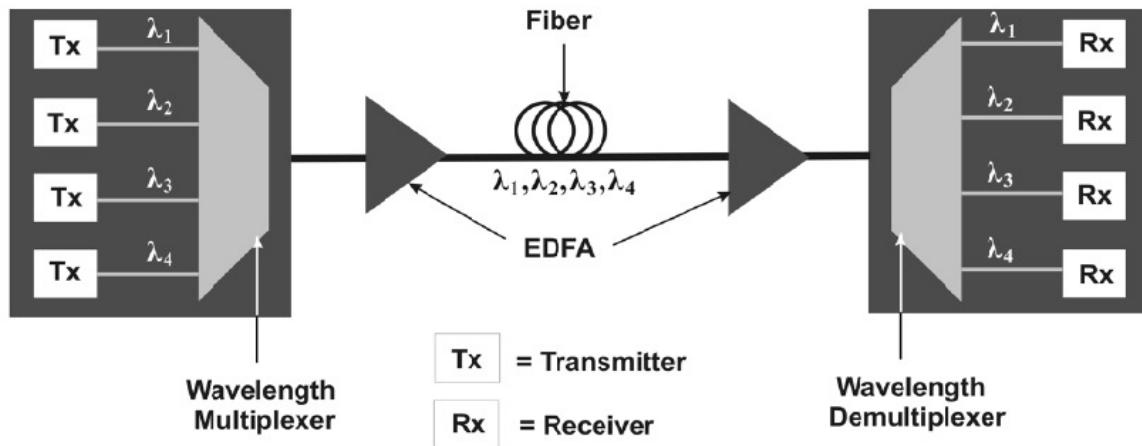


Figure 1.2: WDM system [4]

### 1.3 INTRODUCTION TO FIBER NONLINEAR EFFECTS

The nonlinear effects degrade the system performance. Because nonlinear effects tend to manifest themselves when optical power is very high, they become important in DWDM. Linear effects such as attenuation and dispersion can be compensated, but nonlinear effects accumulate [5]. They are the fundamental limiting mechanisms to the amount of data that can be transmitted in optical fiber. The most important types of nonlinear effects are stimulated Brillouin scattering, stimulated Raman scattering, self-phase modulation, and four-wave mixing. The Kerr nonlinearities are self-phase modulation (SPM), crossphase modulation (XPM) and four-wave mixing (FWM) which become important for long distance transmission. XPM and FWM are multi-channel nonlinearities. SPM is single-channel nonlinearity. FWM efficiency is also a function of signal polarization and the effect of polarization can be seen in the system using the extra component called polarizer [6]. It has been observed that, the information capacity of a lightwave is ultimately limited by the nonlinear interactions between the information signals and

the fiber medium [7]. These optical nonlinear interactions can lead to interference, distortion and attenuation of the signals, resulting in system degradation [7]. The nonlinear effects in fibers can be broadly classified into two categories: stimulated scattering effects and Kerr effects. The scattering effects are due to the interaction of light waves with molecular or sound waves in fiber. The scattering effects include Brillouin scattering (SBS) and Stimulated Raman Scattering (SRS) [8]. The SRS causes a power transfer between WDM channels, but it can be mitigated by the gain equalization schemes [9]. The impact of SBS in a long-haul DWDM system is not critical due to lower channel power, but it is an important consideration in cable television transmission systems [6]. The Kerr effects occur because of the variation of refractive index of the fiber core with optical power. The Kerr effects degrade the DWDM long-haul system performance more significantly than scattering effects [5, 7, 10]. Hence impairments due to scattering effects, are ignored in DWDM systems [6, 7]. The fiber non-linearity which affects only the phase of the propagating signal is called the self-phase modulation (SPM) [10, 11]. SPM is a single-channel effect and the interaction of SPM with fiber dispersion results in pulse broadening or eye closure at the receiver. The pulse spreading caused by SPM depends on channel power, fiber length and dispersion [11]. Cross-phase modulation (XPM) is similar to SPM, where the intensity modulation of one carrier modulates the phases of other co-propagating carriers [11-14]. XPM is multi-channel effect. The magnitude of XPM depends on fiber dispersion, fiber length, channel spacing and bit rate [13]. Larger the channel spacing yields less XPM [5]. Four-wave mixing (FWM) is a parametric process in which different frequencies interact and by frequency mixing generate new spectral components [14]. The magnitude of FWM efficiency depends on channel power, channel spacing and fiber dispersion but is independent of the bit rate [15].

## **1.4 INTRODUCTION TO FOUR WAVE MIXING**

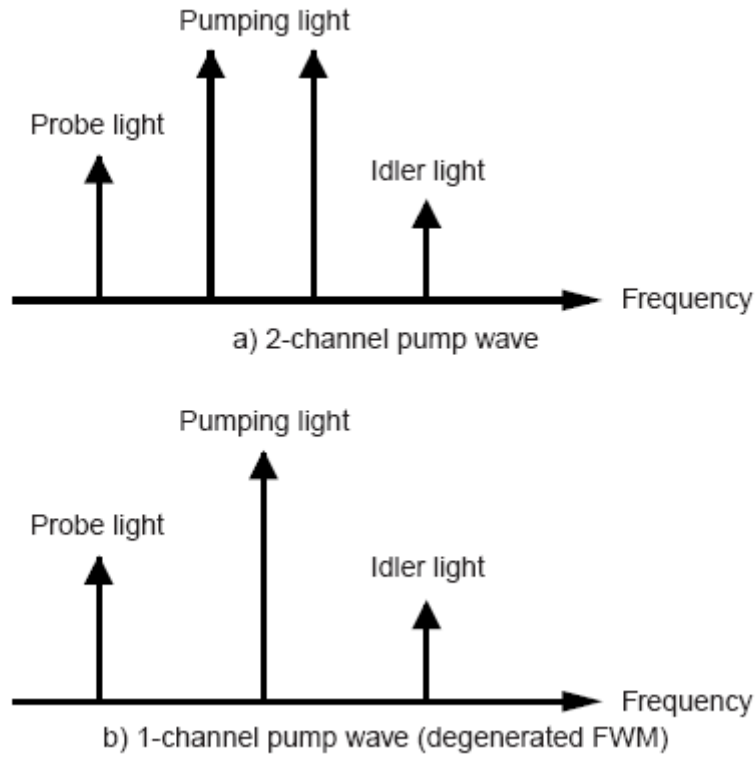
When a high-power optical signal is launched into a fiber, the linearity of the optical response is lost. One such nonlinear effect, which is due to the third-order electric susceptibility is called the optical Kerr effect [16, 17]. Optical fiber nonlinearities can lead to interference, distortion, and excess attenuation of the optical signals, resulting in performance degradation. The most common nonlinear optical effect of importance in optical fiber communication systems results from the fiber nonlinear refractive index. The nonlinearity in the refractive index is known as

Kerr nonlinearities. The Kerr nonlinearity gives rise to different effects, such as self-phase modulation (SPM), cross-phase modulation (XPM), and four-wave mixing (FWM) [18]. FWM may induce lightpath BER fluctuations in dynamic networks that can affect the optical signal to noise ratio and quality of service in transparent networks under highly complex nonlinear effect [19] and influence the frequency chirp and extinction ratio in the system [20]. Four-wave mixing (FWM) is one of the dominating degradation effects in wavelength-division-multiplexing (WDM) systems with dense channel spacing and low chromatic dispersion on the fiber. If in a WDM system the channels are equally spaced, the new waves generated by FWM will fall at channel frequencies and, thus, will give rise to crosstalk. In case of full in-line dispersion compensation, i.e., 100% dispersion compensation per span, the FWM crosstalk becomes of a maximum level since the FWM products add coherently in each span [21]. Four-wave mixing (FWM) is a parametric process in which different frequencies interact and by frequency mixing generate new spectral components [22]. Four-wave mixing (FWM) is a type of optical Kerr effect, and occurs when light of two or more different wavelengths is launched into a fiber. Generally speaking FWM occurs when light of three different wavelengths is launched into a fiber, giving rise to a new wave (known as an idler), the wavelength of which does not coincide with any of the others. FWM is a kind of optical parametric oscillation. In the transmission of dense wavelength-division multiplexed (DWDM) signals, FWM is to be avoided, but for certain applications, it provides an effective technological basis for fiber-optic devices. FWM also provides the basic technology for measuring the nonlinearity and chromatic dispersion of optical fibers.

Figure 1.3 is a schematic diagram that shows four-wave mixing in the frequency domain. As can be seen, the light that was there from before launching, sandwiching the two pumping waves in the frequency domain, is called the probe light (or signal light). The idler frequency  $f_{\text{idler}}$  may then be determined by

$$f_{\text{idler}} = f_{p1} + f_{p2} - f_{\text{probe}}$$

where  $f_{p1}$  and  $f_{p2}$  are the pumping light frequencies, and  $f_{\text{probe}}$  is the frequency of the probe light [16, 17]. This condition is called the frequency phase-matching condition.



**Figure 1.3** Schematic of four wave mixing in frequency domain [23]

The FWM power generated at the end of the fiber due to interaction of channels at frequencies,  $f_i$ ,  $f_j$  and  $f_k$  is given by

$$P_{\text{FWM}} = ((1024 \pi^6)/(n^4 \lambda^2 c^2)) [D\chi]^2 ((P_i P_j P_k)/(A_{\text{eff}}^2)) L_{\text{eff}}^2 \eta e^{-aL}$$

where  $P_i$ ,  $P_j$  and  $P_k$ , refer to the soliton input powers at frequency  $f_i$ ,  $f_j$  and  $f_k$  respectively,  $n$  is the fiber effective refractive index,  $\lambda$  is the zero dispersion wavelength,  $c$  is the velocity of light,  $\chi$  is the 3rd order nonlinear susceptibility of the single mode fiber,  $A_{\text{eff}}$  is the effective mode area of the fiber,  $L_{\text{eff}}$  is the fiber effective length,  $a$  is fiber attenuation coefficient and  $D$  is the degeneracy factor, where  $D = 6$  for  $i = j$  and  $D = 3$  for  $i \neq j$ .

The FWM light generation efficiency is given by

$$\eta = \left( \frac{\alpha^2}{M^2 (\alpha^2 + \Delta\beta^2)} \right) \left( \frac{\sin^2 (M \Delta\beta L_{a/2})}{\sin (\Delta\beta L_{a/2})} \right) \cdot \left( 1 + \frac{4 \exp(-\alpha L_a) \sin^2 (\Delta\beta L_{a/2})}{(1 - \exp(-\alpha L_a))^2} \right)$$

where M refers to the number of fiber sections and  $\Delta\beta$ , the phase mismatching constant, in general, can be written as  $\Delta\beta = \beta (f_i) + \beta (f_j) - \beta (f_k) - \beta (f_{\text{FWM}})$  where  $\beta$  represents the propagation constant [24].

## 1.5 APPLICATIONS OF FWM

Multiwave mixing, especially four-wave mixing (FWM), is a fundamental process in nonlinear optics. Nonlinearity couples the underlying modes, generating new sum and difference frequencies from the original waves. In the typical scenario, two pump waves interact with a signal wave, creating a daughter wave that is phase conjugated with the signal [25]. While dispersion creates issues of phase matching, FWM has proved useful in such applications as realtime holography, supercontinuum generation, and soliton communication systems [26]. The most common configuration involves a self-focusing nonlinearity and a backward geometry, in which the initial pump beams counterpropagate to create a reflection grating. The focusing nonlinearity has the advantage of intensity concentration, but higher intensity can lead to other nonlinear effects, while the spatial (transverse) extent of interaction is limited by modulation instability. Furthermore, the backward geometry makes it difficult to cascade the wave mixing and follow the evolution of daughter waves. Here, we consider a forward (transmission) geometry, with all beams copropagating, in a self-defocusing medium [19].

Investigation of FWM effect on varying various parameters has been discussed in the further chapters.

# CHAPTER 2

## LITERATURE REVIEW

---

### 2.1 LITERATURE SURVEY

A. J. Mendez et al. [2] presented a technique for generating PSO matrices from sets of optimum Golomb rulers. It is shown that 2D codes have higher cardinality and good spectral efficiency, especially when compared to linear or direct sequence code. This paper describes the design and construction of the matrices; analyzes their performance from a communications viewpoint; describes their use as codes for the asynchronous, concurrent communication of multiple users; and analyzes the bit error rate performance based on capturing and modeling a typical network topology and performing a numerical modeling of the system.

Diptish Dey et al. [4] presented the concept for building a packet switched MAN with support for multicasting in the optical domain. The MAN comprises of interconnected all-optical rings. Slots transport data packets within each ring all-optically. This enables optical packet-switching at intermediate nodes on a ring. The nodes are capable of transmitting and receiving at all wavelengths. Problems such as slot-synchronization (chromatic dispersion), crosstalk accumulation and SNR degradation have been simulated, analyzed and/or experimentally demonstrated.

Yutaka Miyamoto et. al. [8] described recent technical challenges and the progress towards the realization of the optical transport network based on 43 Gb/s channel. They proposed 43-Gb/s/ch dense wavelength-division multiplexing (DWDM) dispersion-managed transmission system using carrier-suppressed return-to-zero (CS-RZ) format.

Takehiro Tsuritani et. al. [9] investigated ultra-long-haul 42.7-Gbit/s-based dense wavelength-division multiplexing (DWDM) transmission using optically prefiltered carrier-suppressed return-to-zero signal. They experimentally investigated the optimum filtering condition for 65- or 45-GHz-wide prefiltered CS-RZ signals in the ultra-long-haul DWDM transmission and

conducted the 70- and 50-GHz spaced 32 x 42.7 Gbit/s transmission using prefiltered CS-RZ signals.

Jin-Xing Cai et. al. [10] investigated the impact of receiver dispersion slope compensation for 40-Gb/s transoceanic transmission over conventional nonzero dispersion shifted fibers. Various differential phase-shift keying (DPSK) modulation formats were experimentally compared at 42.8 Gb/s with dispersion slope compensators at the receiver.

Masahiro Daikoku et. al. [11] conducted single-polarization 160Gbit/s-based field transmission experiments. They achieved single-channel transmission and 8 WDM transmission with 300GHz channel spacing over the inter-city 200km SMF by utilizing 160Gbit/s RZ-DPSK signals and a simple PMD compensator.

Lara D. Garrett et. al. [12] demonstrated a bidirectional transmission system with 16 10-Gb/s dense wavelength-division-multiplexing channels on 32 wavelengths over 5000 km of nonzero dispersion-shifted fiber in a fully bidirectional recirculating loop, for a full-duplex capacity-distance product of 800 Tb/s/km.

L. H. Spiekman et. al. [13] modulated eight DWDM channels in the wavelength region 1558-1570 nm, spaced at 200 GHz at 20 Gb/s and transmitted over 160 km using four in-line SOA's.

G. Charlet et. al. [14] evaluated the impact of a variable channel spacing on the Q-factor assuming RZ-DPSK format at 40 Gbit/s channel rate in five WDM experiments conducted in a recirculating loop over transoceanic distances. A degradation of the Q-factor by nearly 3 dB was observed when the channel spacing was reduced from 100 to 50 GHz.

E. Pincemin et. al. [15] examined the impact of the fiber type and dispersion management on the performance of a 16 x 40 Gb/s dense wavelength-division-multiplexing non return-to-zero transmission system.

P. L. Li et. al. [19] presented a comprehensive broad-band model of tunable wavelength converter based on four-wave mixing (FWM) in semiconductor fiber ring laser. They considered the critical factors like the material gain profile, the longitudinal variation of the optical field, the

carrier density and the broad-band spontaneous noise emission in the model. They investigated the effects of the input signal power, injection current, the coupling of the output coupler and the lasing wavelength on the performance of the wavelength converter, such as the conversion efficiency.

A. Yariv et. al. [26] proposed and analyzed a number of new optical effects that result from degenerate four-wave mixing in transparent optical media. The applications were relevant to time-reversed (phase-conjugated) propagation as well as to a new mode of parametric oscillation.

Agarwal et. al. [29] discussed the case of equal bit rates and equal received power in all channels and observed that the crosstalk from each channel should be below -12 dB. Further he proposed that the minimum channel spacing of about 4 or 5 times the bit rate is dependent upon the filter bandwidth whether it is 2 or 3 times respectively. To reduce the power penalty below 0.1 dB, crosstalk should be less than -18 dB and should have a minimum channel spacing of about 10 times the bit rate.

David F. Geraghty et. al. [31] discussed that four-wave mixing (FWM) in semiconductor optical amplifiers is an attractive mechanism for wavelength conversion in wavelength-division multiplexed (WDM) systems since it provides modulation format and bit rate transparency over wide tuning ranges. They presented a series of experiments evaluating several aspects of the performance of these devices at bit rates of 2.5 and 10 Gb/s. They also presented time resolved spectral analysis of wavelength conversion.

C. A. Brackett et. al. [34] presented an architectural approach for very-high-capacity wide-area optical networks, and described a proposed program of research to address key system and device issues. The network was based on dense multi-wavelength technology and was scalable in terms of the number of networked users, the geographical range of coverage, and the aggregate network capacity. They employed a distributed optical interconnect that is wavelength-selective and electronically controllable, permitting the same limited set of wavelengths to be reused among other access stations.

J. M. Wiesenfeld et. al. [35] reviewed the dynamic processes like interband and intraband dynamics and their origins. They said that under conditions of large, time varying changes in

carrier density, the nonlinear gain and refraction becomes significant. They applied the nonlinearities of cross phase modulation and four wave mixing in semiconductor optical amplifiers for the functions of wavelength conversion and clock recovery.

B. Glance et. al. [36] translated the data at 10 Gbps from an input signal wavelength to another wavelength, either longer or shorter, using gain compression in a semiconductor optical amplifier for wavelength conversion. They observed that to achieve operation at such high bit rates, the probe input must be intense enough to compress the gain of the amplifier significantly.

T. Durhuus et. al. [37] gave an in depth analysis of cross gain and cross phase wavelength conversion in semiconductor optical amplifiers. They explained the influence of saturation filtering on the bandwidth of the converters and identified the conditions for conversion at 20 Gbps or more. They observed that cross gain modulation scheme shows extinction ratio degradation for conversion to longer wavelengths.

S. J. B. Yoo et. al. [40] reviewed various wavelength conversion techniques, discussed the advantages and shortcomings of each technique, and addressed their implications for transparent networks.

J. Zhou et. al. [41] studied ultrafast dynamics in a tensile-strained quantum-well optical amplifier by highly non degenerate four-wave mixing at detuning frequencies up to 1.7 THz. Frequency response data indicated the presence of two ultrafast physical processes with characteristic relaxation lifetimes of 650 fs and  $< 100$  fs.

Yasin M. Karfaa et. al. [42] presented a comprehensive theoretical study of four-wave mixing in optical fiber with exploring four fiber types. They integrated corresponding system of equations numerically and described the channels interaction phenomena such as four-wave mixing. They evaluated the system performance through determining the average bit error rate relation with both of the frequency and wavelength of transmitted optical channels in the presence of four-wave mixing crosstalk noise.

C. T. Politi et. al. [43] investigated the wavelength dependent behavior of a wavelength converter and the requirement for a widely tunable converter. They also studied a configuration for extinction ratio improvement.

M.N.Peterson et. al. [44] described the first demonstration of chromatic dispersion monitoring in optical networks having employed all-optical wavelength conversion. Their experimental results confirmed that dispersion monitoring based on an in-band subcarrier tone combined with wavelength conversion based on four-wave mixing (FWM) render dispersion monitoring possible in an optical network utilizing wavelength conversion.

Hedekvist et al. [48] presented an all-optical time- division de-multiplexer with 22 dB conversion efficiency, using FWM at 1550 nm in a single-mode dispersion-shifted fiber. Error-free de-multiplexing of 20 Gb/s data to 10 Gb/s was obtained, with 1.4 dB power penalty BER  $\frac{1}{4} 10^{-9}$ .

Hwang et. al. [49] described the comparisons of power penalty due to FWM between equal channel spacing and the unequal channel spacing for the 20-channel WDM system. They show that for an intensity modulation/direct detection transmission system operating in an optical bandwidth of 16 nm with 0 dBm (1mW) peak optical input power per channel achieve BER  $\frac{1}{4} 10^{-9}$  with an FWM cross-talk power of less than 1 dB, which was not achieved by a conventional equal channel spacing WDM system with 0.84 nm channel spacing.

Witte et al. [50] proposed that the power penalty encountered in linear electronic compensation of dispersion-induced LED pulse distortion could be reduced by using an electronic decision feedback equalization scheme.

## **2.2 MOTIVATION**

According to the literature survey, it has been observed that maximum work has been done in the field of using four wave mixing for wavelength conversion. The investigation of four wave mixing effect on bit error rate, eye opening and Q-factor with changing parameters has rarely been done. The bit error rate decreases with increasing number of channels/users. Most arguments advocating four wave mixing for wavelength conversion in the research literature are

qualitative and vague. Various approaches have been suggested for decreasing the fiber nonlinearity named as four wave mixing. According to ITU-T standards, four wave mixing effect has been evaluated above channel spacing of 25 GHz but no evaluation has been done for channel spacings below 25 GHz, yet. In this paper, comparison of four wave mixing is done for ultra low values of spacing. As the channel spacing increases, the four wave mixing effect decreases. The four wave mixing effect on bit error rate, Q-factor, output spectrums and eye opening for different channel spacing; different number of channels and varying each transmitting component in the circuit has not been studied yet.

## **2.3 OBJECTIVES OF THESIS**

The objectives of the thesis are:

- To investigate the four wave mixing effect on BER, Q-factor, eye opening and output spectrums at ultra low channel spacing.
- To design and analyze the performance of four wave mixing effect with different optical transmitter components.
- To investigate four wave mixing effect with different number of channels at various channel spacings.

## **2.4 ORGANIZATION OF THESIS**

This thesis is divided into six chapters.

The first chapter presents a brief introduction of multiplexing techniques and different fiber nonlinearities which includes self phase modulation, cross phase modulation and four wave mixing.

The second chapter includes the literature survey of various applications of four wave mixing effect. The literature survey of investigating the four wave effect on changing the channel spacing has also been done.

In the third chapter, investigation of four wave mixing effect on bit error rate, Q-factor, output spectrums and eye diagrams at different channel spacings (6.25 GHz, 10 GHz, 20 GHz, 25 GHz, 75 GHz) has been done. All the parameters like bit error rate etc have been analyzed in the form of graphs.

In the fourth chapter, the design, implementation and performance analysis of four wave mixing in optical communication system on changing the different components in the circuit is

presented. Components involve different data sources like pn-sequence generator with different bit rate; modulator drivers like NRZ and RZ raised cosine, NRZ and RZ rectangular, RZ supergaussian, RZ soliton; modulators like linear amplitude, linear electroabsorption and optical phase modulator. After that, the four wave mixing effect has been analyzed for different values of laser power in terms of BER, Q-factor and eye opening.

The fifth chapter investigates the four wave mixing effect in optical communication system for different number of input channels at various values of channel spacing. All the input channels are spaced evenly at various values like 6.25 GHz, 12.5 GHz, 25 GHz, 40 GHz, 50 GHz with the different number of channels at the input i.e. with 2, 4, 6, 8, 12 input channels. The effect of four wave mixing has been analyzed for each channel spacing with these number of channels in terms of eye diagrams, BER, eye opening and Q-factor.

Finally, the sixth chapter includes conclusion and future scope of the work done.

## CHAPTER 3

# INVESTIGATION OF FOUR WAVE MIXING EFFECT ON BER, Q-FACTOR AND EYE OPENING AT ULTRA LOW CHANNEL SPACING

---

In this chapter, the four wave mixing effect has been compared for different values of ultra low channel spacing and the performance has been evaluated in terms of output spectrums, eye diagrams, BER, eye opening and Q-factor. Here, all the channels are spaced evenly but at different values like 6.25 GHz, 10 GHz, 20 GHz, 25 GHz and 75 GHz. The simulation results reveal that four wave mixing is minimum at high wavelength spacings. Further, it has been observed that on increasing the spacing between input channels, their interference with each other decreases and thus, the four wave mixing effect also decreases. At ultra low channel spacing of 6.25 GHz, the four wave mixing effects are maximum.

### 3.1 INTRODUCTION

Four-wave mixing (FWM) (also called four-photon mixing) is one of the major limiting factors in WDM optical fiber communication systems that use the low dispersion fiber or narrow channel spacing. Normally, multiple optical channels passing through the same fiber interact with each other very weakly. However, these weak interactions in glass can become significant over long fiber-transmission distances. The most important is FWM in which three wavelengths interact to generate a fourth [16]. FWM is due to changes in the refractive index with optical power called optical Kerr effect. FWM is a third- order non-linearity in silica fibers that is analogous to inter-modulation distortion in electrical systems. When three electro-magnetic waves with optical frequencies co- propagate through one fiber, they mix to produce a fourth inter-modulation product. In the FWM effect, three co- propagating waves produce nine new optical sideband waves at different frequencies. When this new frequency falls in the transmission window of the original frequencies, it causes severe cross talk between the channels

propagating through an optical fiber. FWM occurs when light of three different wavelengths is launched into a fiber; it gives rise to a new wave [27]. This newly generated wave as a result of FWM co-propagates with the originally transmitted signal and interferes with them. It causes severe degradation for the WDM channels and introduces the crosstalk and required power to reduce the crosstalk [28]. When a high-power optical signal is launched into a fiber, the linearity of the optical response is lost. One such nonlinear effect, which is due to the third-order electric susceptibility is called the optical Kerr effect [16, 17]. Four-wave mixing (FWM) is a type of optical Kerr effect, and occurs when light of two or more different wavelengths is launched into a fiber. The light present before launching, sandwiching the two pumping waves in the frequency domain, is called the probe light (or signal light). The idler frequency  $f_{\text{idler}}$  may then be determined by

$$f_{\text{idler}} = f_{p1} + f_{p2} - f_{\text{probe}}$$

where  $f_{p1}$  and  $f_{p2}$  are the pumping light frequencies, and  $f_{\text{probe}}$  is the frequency of the probe light [16, 17]. This condition is called the frequency phase-matching condition.

Multiwave mixing, especially four-wave mixing (FWM), is a fundamental process in nonlinear optics. Nonlinearity couples the underlying modes, generating new sum and difference frequencies from the original waves. In the typical scenario, two pump waves interact with a signal wave, creating a daughter wave that is phase conjugated with the signal [25]. While dispersion creates issues of phase matching, FWM has proved useful in such applications as realtime holography, supercontinuum generation, and soliton communication systems [26]. The most common configuration involves a self-focusing nonlinearity and a backward geometry, in which the initial pump beams counterpropagate to create a reflection grating.

Agarwal et. al. [29] discussed the case of equal bit rates and equal received power in all channels and observed that the crosstalk from each channel should be below -12 dB. Further it was proposed that the minimum channel spacing of about 4 or 5 times the bit rate is dependent upon the filter bandwidth whether it is 2 or 3 times respectively. To reduce the power penalty below 0.1 dB, crosstalk should be less than -18 dB and should have a minimum channel spacing of about 10 times the bit rate.

Hwangand Tonguzc et. al. [30] described the comparisons of power penalty due to FWM between equal channel spacing and the unequal channel spacing for the 20-channel WDM

system. It was shown that for an intensity modulation/direct detection transmission system operating in an optical bandwidth of 16 nm with 0 dBm (1mW) peak optical input power per channel achieve BER  $\frac{1}{4} 10^{-9}$  with an FWM cross-talk power of less than 1 dB, which was not achieved by a conventional equal channel spacing WDM system with 0.84 nm channel spacing.

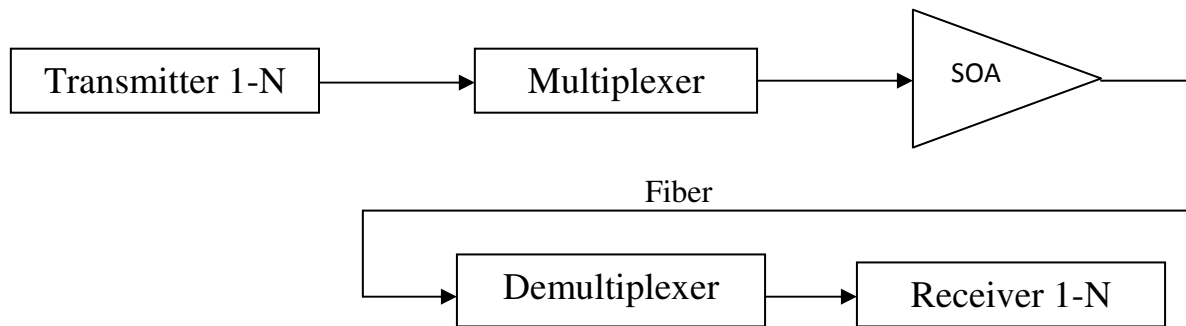
G. Charlet et. al. [14] evaluated the impact of a variable channel spacing on the Q-factor assuming RZ-DPSK format at 40 Gbit/s channel rate in five WDM experiments conducted in a recirculating loop over transoceanic distances. A degradation of the Q-factor by nearly 3 dB was observed when the channel spacing was reduced from 100 to 50 GHz.

Up till now, various methods to reduce four wave mixing effect have been proposed and theoretically compared. Comparison of power penalty for different fiber lengths and dispersion values has been done but the comparison on the basis of different spacing between input channels is rarely considered. According to ITU-T standards, four wave mixing effect has been evaluated above channel spacing of 25 GHz but no evaluation has been done for channel spacings below 25 GHz, yet. In this chapter, comparison of four wave mixing is done for ultra low values of spacing i.e. 6.25 GHz, 10 GHz, 20 GHz, 25 GHz, 75 GHz and their comparison has been done between different users.

This chapter is divided into different sections. In the first section, the introduction of four wave mixing effect is presented. In the second section, the schematic model is proposed. The third section describes the simulation setup for an optical communication system implementing these requirements. In the fourth section, the comparison of performance of four wave mixing on the basis of different spacing values is done in terms of output spectrums, eye diagrams, BER, Q-factor. The fifth section gives the conclusion of this chapter.

## **3.2 SCHEMATIC MODEL**

The schematic model for an optical communication system implementing the four wave mixing effect for various values of spacing between different users is presented in figure 3.1. N input channels/users are taken in this case for reference. The number of users can vary depending on various constraints like the bandwidth range.



**Figure 3.1** Schematic model

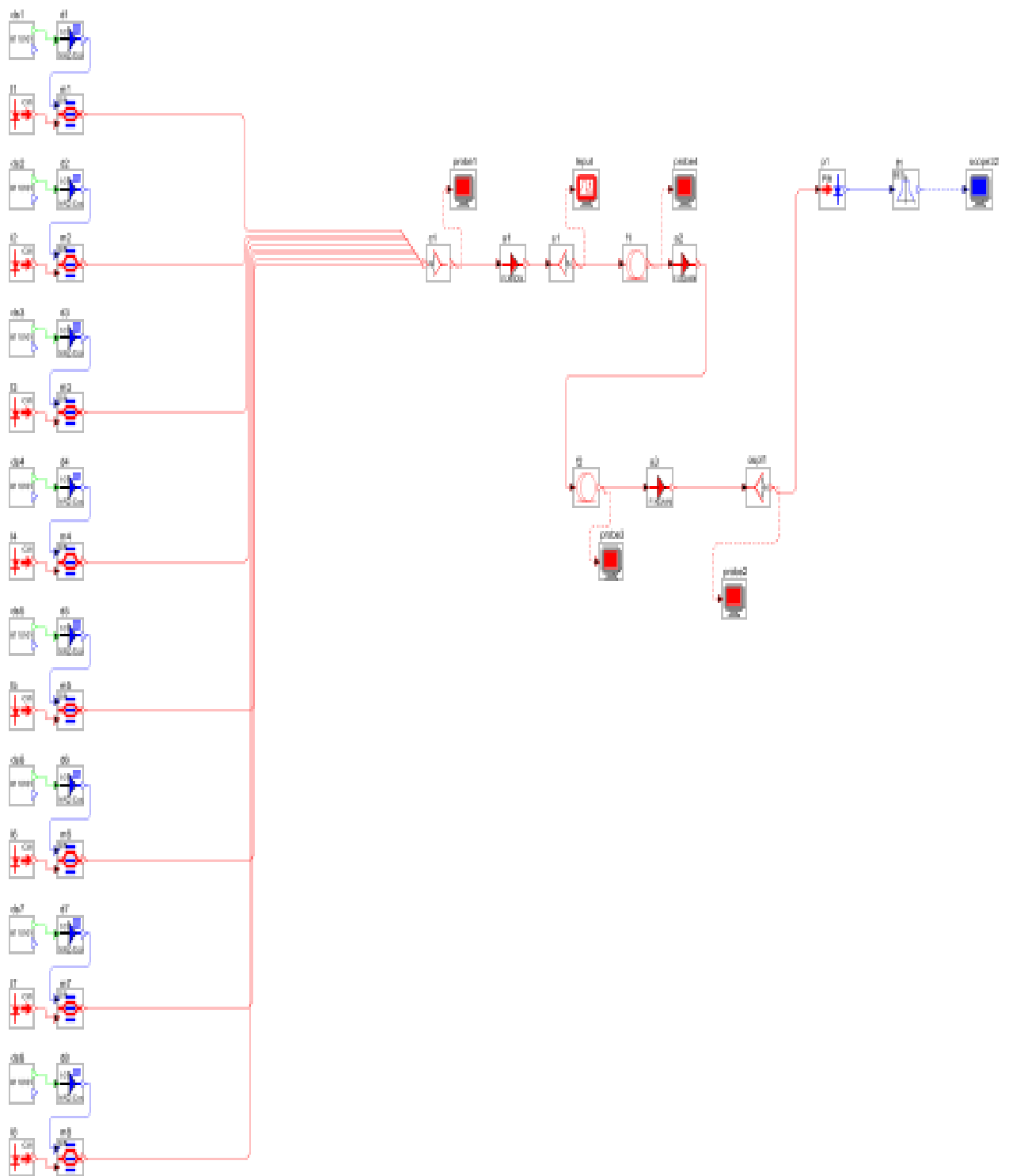
This schematic model is the general setup for an optical communication system in which non linear fiber is installed which adds non linearities like four wave mixing. The post-amplifier, in-line amplifier and pre-amplifier are used in case of long transmission distances.

The transmitter section consists of a laser, modulator driver, pn-sequence generator i.e. data source and modulator. The wavelength of various channels is set by keeping the difference equal to the spacing required. Then all these transmitted signals are combined/multiplexed together. Then the combined signal is amplified so that it can be transmitted over long distances without its degradation. Then the signal is transmitted over the non linear fiber which adds the non linearities into the signal. At the receiver side, the signal is demultiplexed. The receiver consists of a photodiode and a low pass filter.

### 3.3 SIMULATION SETUP

The simulation setup for showing the effect of changing spacing between the input channels on four wave mixing is shown in figure 3.2. The continuous wave laser (L1-L8) is used to create the carrier signal. In this setup, eight users are taken in account whose wavelengths have a specific difference i.e. spacing between them. The frequency of first user is kept at 192.98 nm. The wavelengths of next users is set as per the spacing requirement i.e. at wavelength difference of 6.25 GHz, 10 GHz, 20 GHz, 25 GHz, 75 GHz. The data source (ds1-ds8) is used to generate the random input data bit sequence at the rate of 10 Gbps. The light signal modulates the input data. The modulator (m1-m8) is driven by the modulator driver (d1-d8) which decides the input data format. The input data format used here is NRZ raised cosine. The modulated data from all the users is combined using a combiner (c1). The post amplifier (a1) amplifies the signal before

allowing it to enter into the fiber to avoid losses. Then this signal is sent over the fiber (f1) of length 100 Km. All the attenuation, dispersion and non linear effects are activated. The in-line amplifier (a2) amplifies the signal in the transmission medium itself. Then the signal is again passed through a fiber (f2) of length 100 Km. Then pre-amplifier (a3) is used to amplify the signal before allowing it to enter into the receiver section. After amplification, the signal reaches the receiver. At the receiver, the signal is demultiplexed by using a splitter (s1) which splits this signal into the same number of signals as were transmitted. The photodiode (p1) is used for optical to electrical conversion. Then the signal is passed through the Bessel filter (Lf1) which is made to work as low pass filters and the final output signal is received. An optical scope (probe1) is attached at the output of combiner to examine the input signal. Another optical scope (probe2) is placed at the output of splitter to examine the four wave mixing effect in frequency spectrum. An electrical scope (scope32) is kept at the receiver output to examine the eye diagram, BER, Q-factor. Some optical scopes are placed in the intermediate stages to analyze the output.

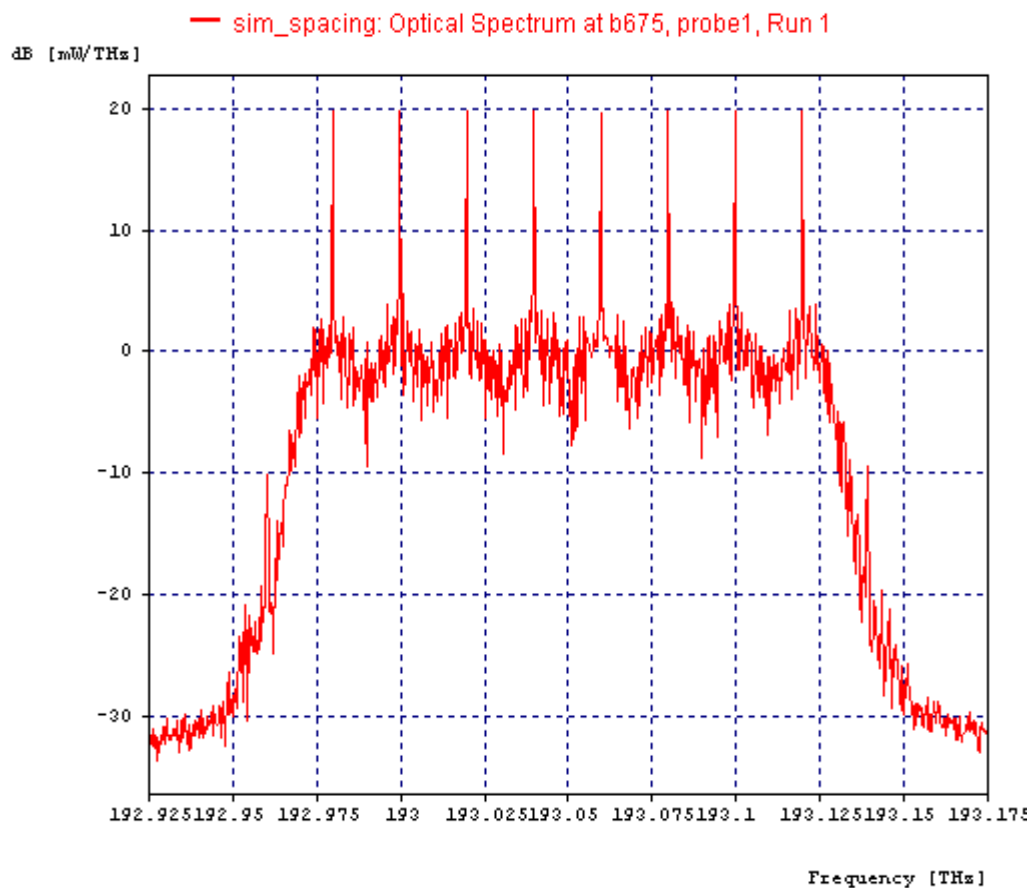


**Figure 3.2** Simulation setup

### 3.4 RESULTS AND DISCUSSION

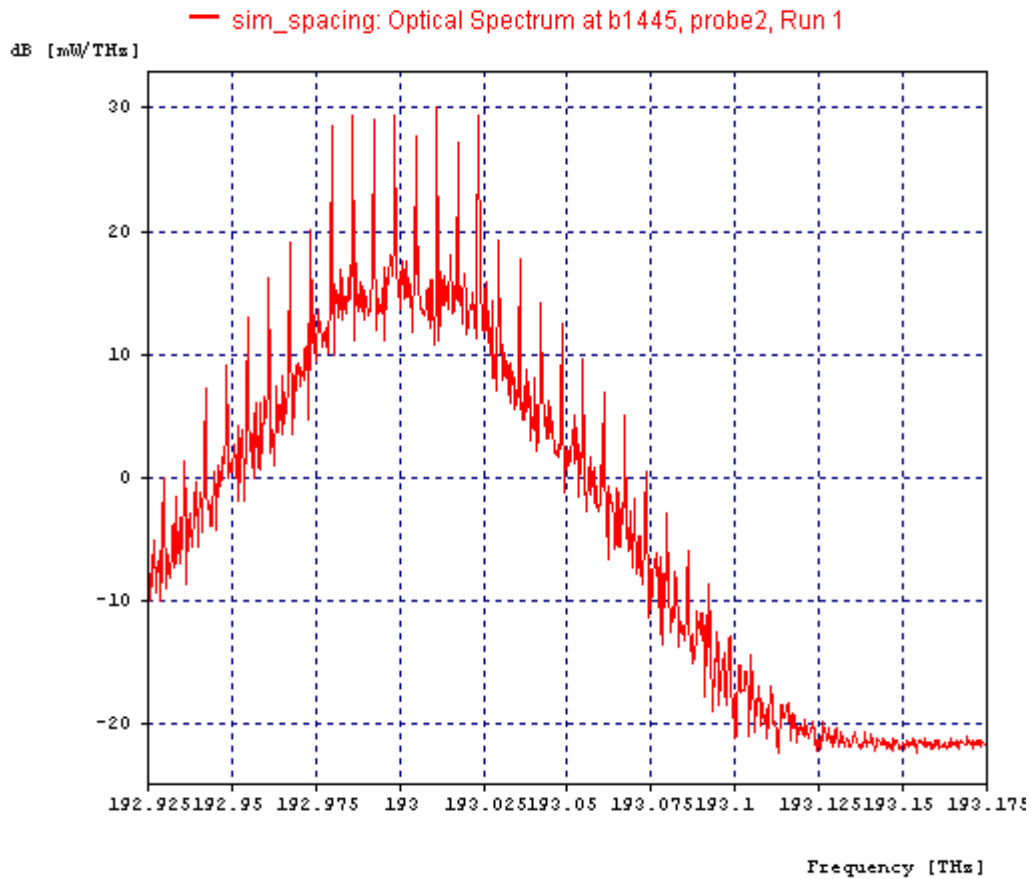
Using simulation setup, the value of BER, Q-factor, eye diagrams, input and output optical spectrums are measured. Optical scope measures the input and output wavelength spectrums. BER, eye diagrams and Q-factor is measured at the receiver output by using an electrical scope.

Figure 3.3 shows the input optical spectrum for the spacing of 20 GHz between input channels. On changing the spacing between the different users, the peaks get shifted to the frequencies as specified in the laser. It is observed that there are no unnecessary side peaks at the input of the fiber. There are eight input channels so eight peaks appear in the input spectrum.



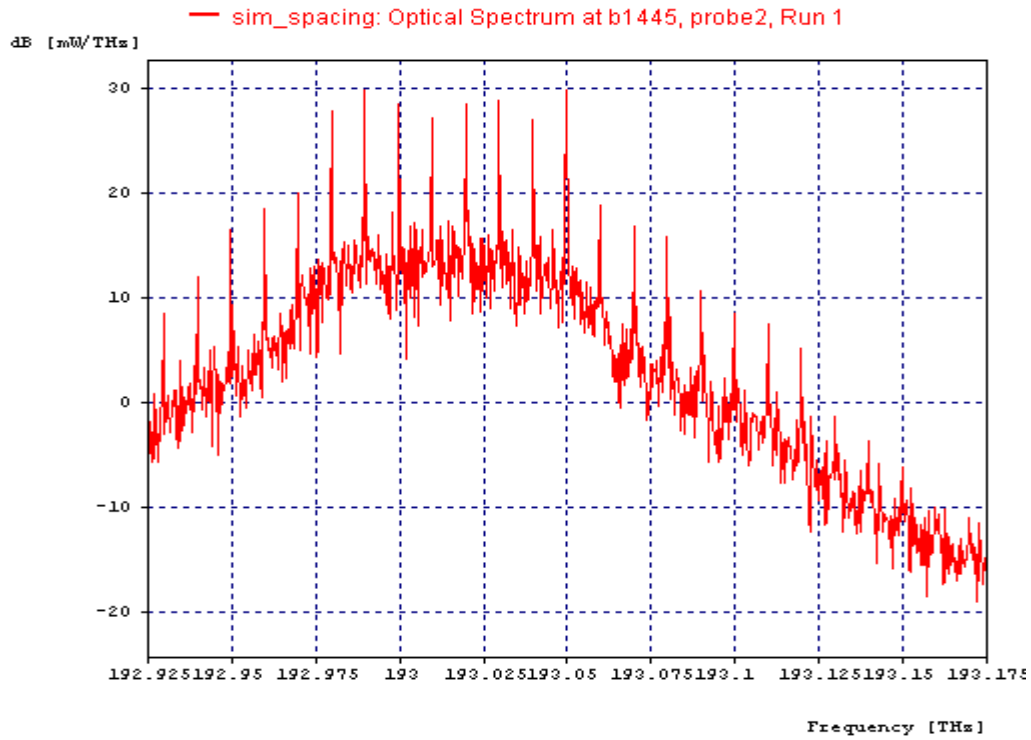
**Figure 3.3** Input optical spectrum used for analyzing FWM effect

Figure 3.4 represents the output spectrum for the various values of spacing between the input users. Figure 3.4 (a) shows the output spectrum for the spacing of 6.25 GHz. Figure 3.4 (b) shows the output spectrum for the spacing of 10 GHz. Figure 3.4 (c) shows the output spectrum for the spacing of 20 GHz. Figure 3.4 (d) shows the output spectrum for the spacing of 25 GHz. Figure 3.4 (e) shows the output spectrum for the spacing of 75 GHz.

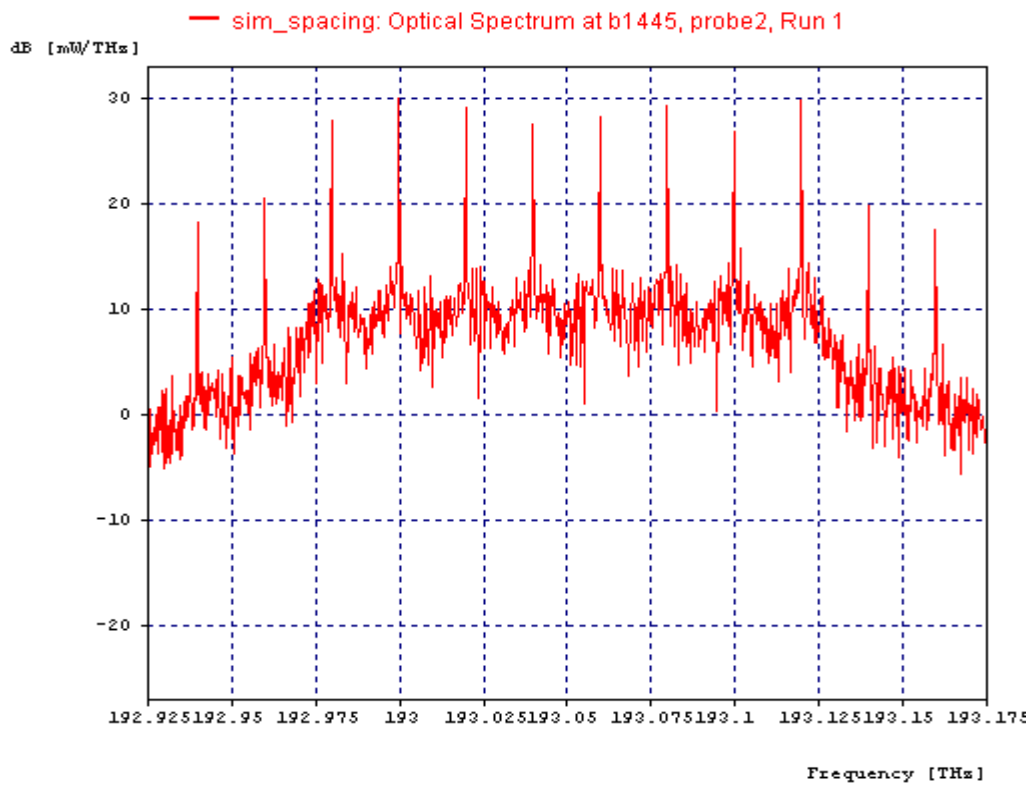


**Figure 3.4 (a)** Output spectrum for 6.25 GHz spacing

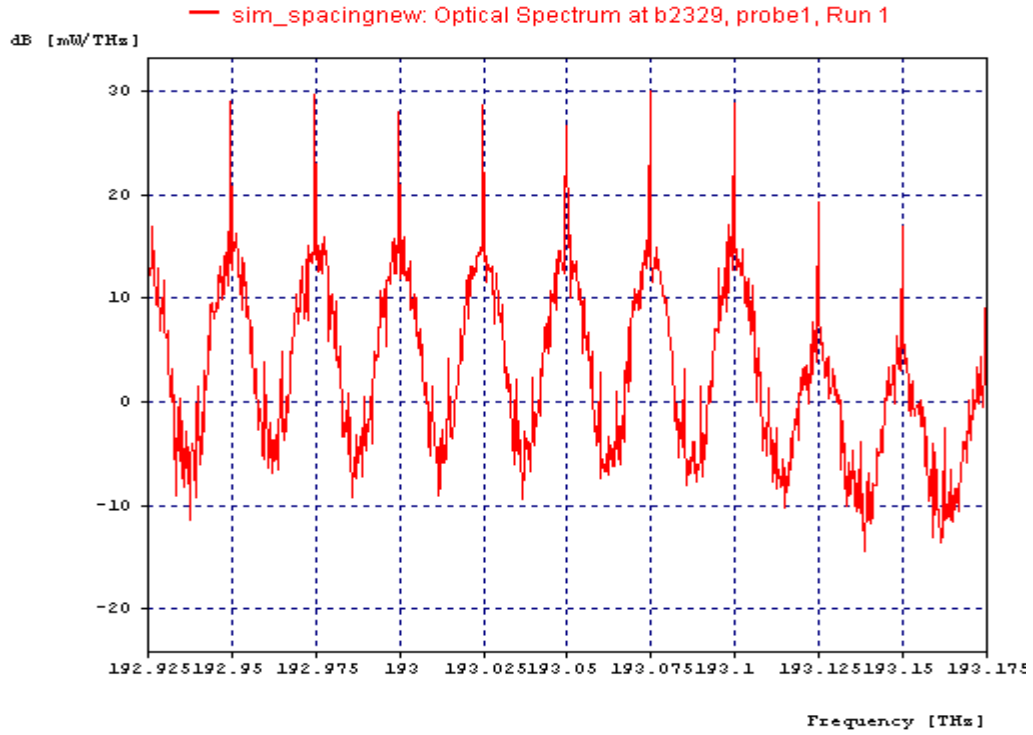
The four wave mixing effect is clearly seen in the above output spectrum for 6.25 GHz spacing as unnecessary peaks at various frequencies are occurring at the sides of the input spectrum. Moreover, the peaks at the input frequencies have also diminished due to four wave mixing occurred after crossing the non linear fiber.



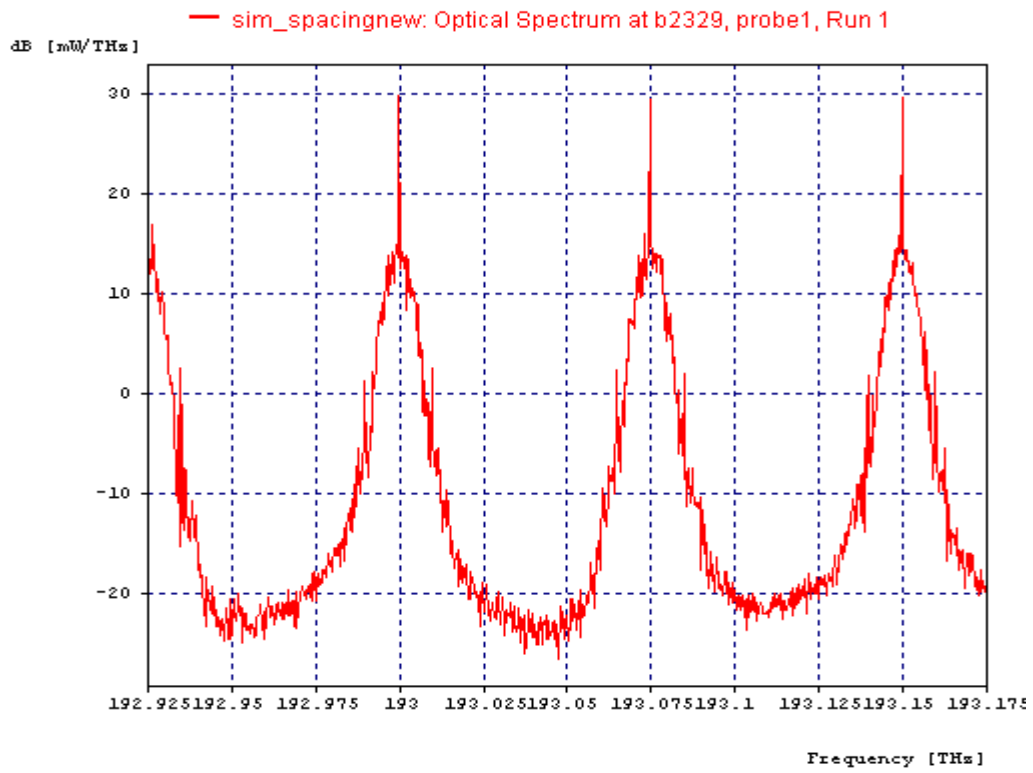
**Figure 3.4 (b)** Output spectrum for 10 GHz spacing



**Figure 3.4 (c)** Output spectrum for 20 GHz spacing



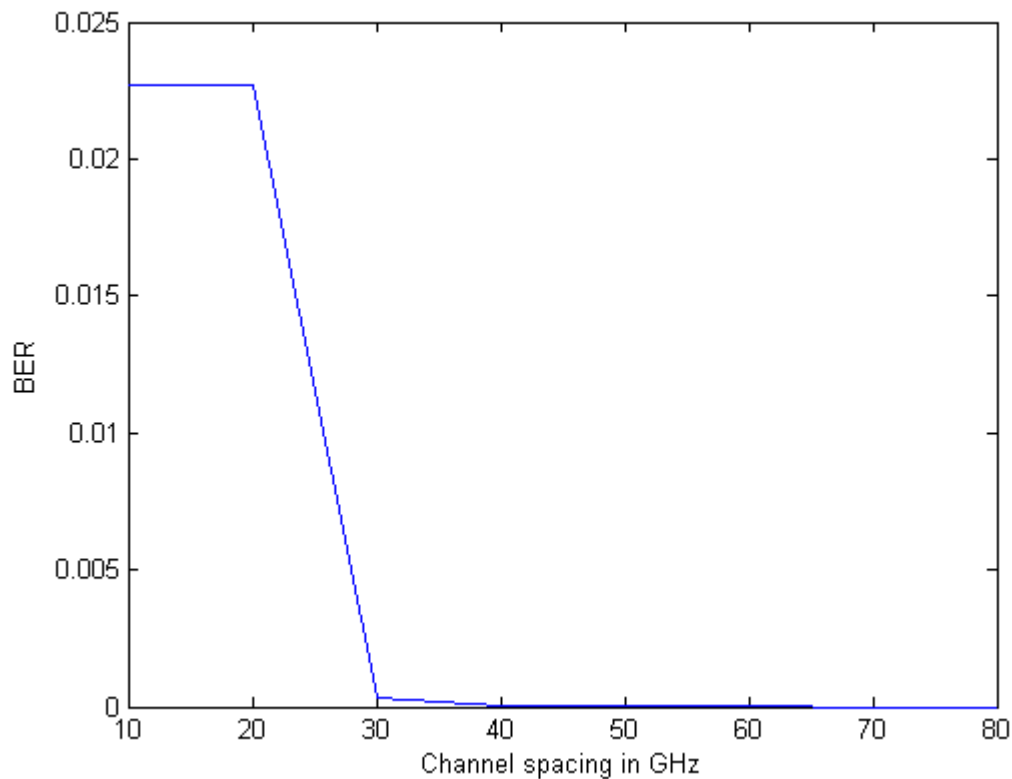
**Figure 3.4 (d)** Output spectrum for 25 GHz spacing



**Figure 3.4 (e)** Output spectrum for 75 GHz spacing

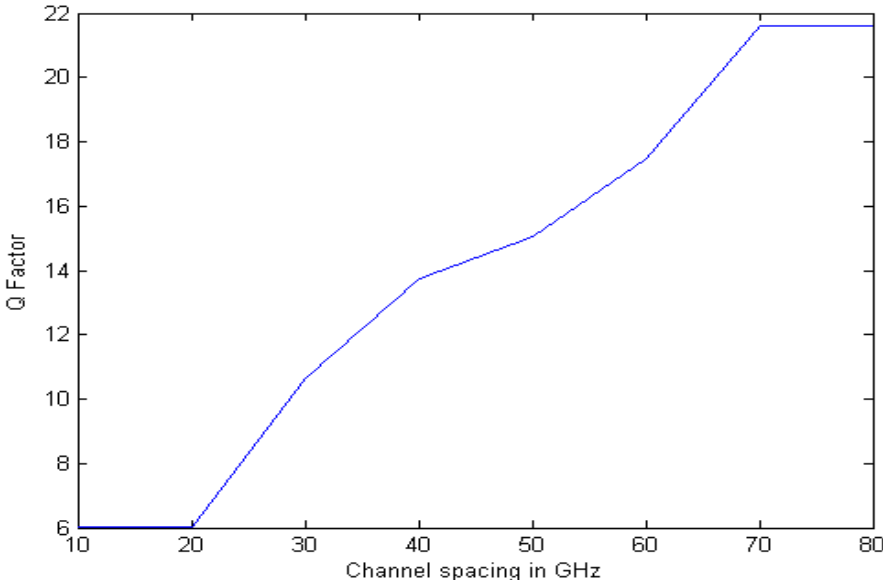
The above spectrums shows that as the spacing between the input channels/users increases, the four wave mixing effect goes on decreasing. The unwanted peaks are maximum when the spacing is 6.25 GHz and are minimum when the spacing is 75 GHz. This shows that lesser the spacing between different input users/channels, more is the interference between the input frequencies i.e. more is the four wave mixing effect. On increasing the spacing between the input channels, the four wave mixing decreases.

Figure 3.5 shows the variation of BER on the basis of spacing between the input channels. The figure shows that BER goes on decreasing with the increasing spacing.

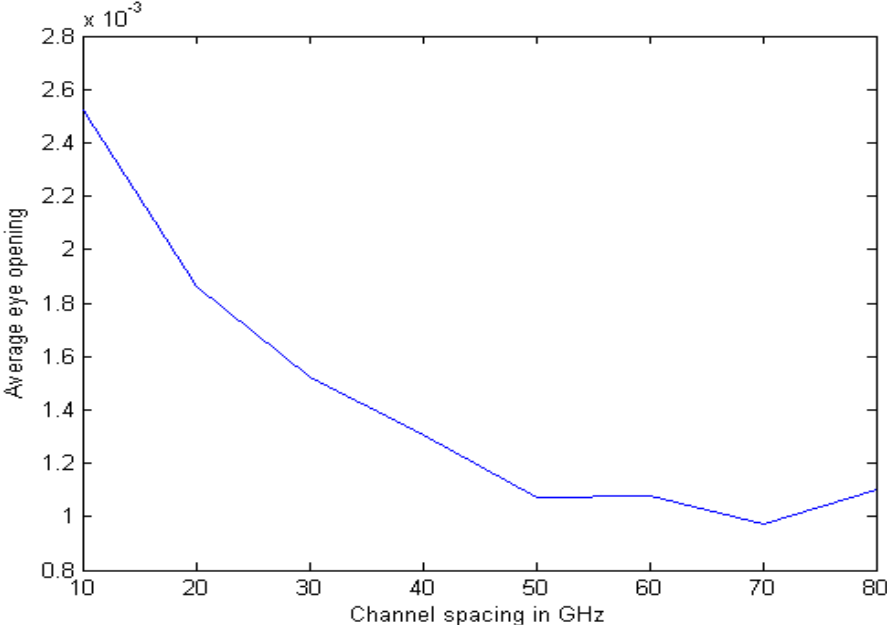


**Figure 3.5** Variation of BER with respect to Channel spacing

Figure 3.6 shows the variation of Q-factor with the spacing between the input channels. The graph shows that the Q-factor increases on increasing the channel spacing. It is maximum when the channel spacing is 80 GHz and is minimum when the channel spacing is 6.25 GHz.



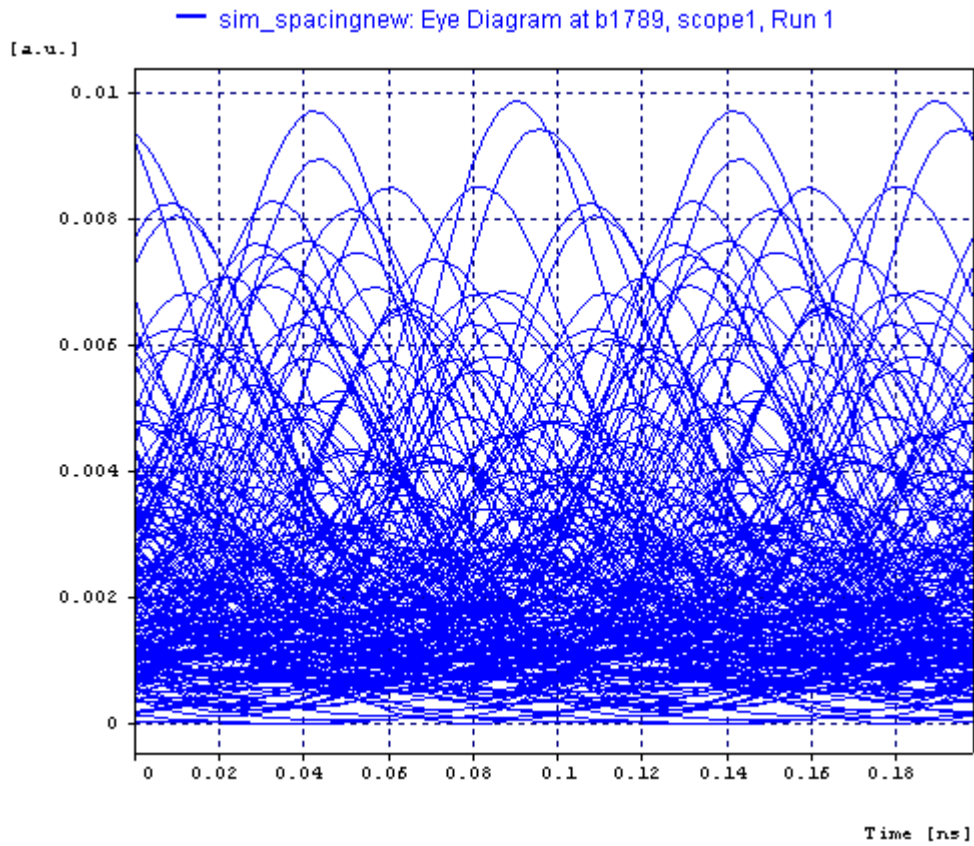
**Figure 3.6** Variation of Q-factor with respect to Channel spacing



**Figure 3.7** Variation of Eye opening with respect to Channel spacing

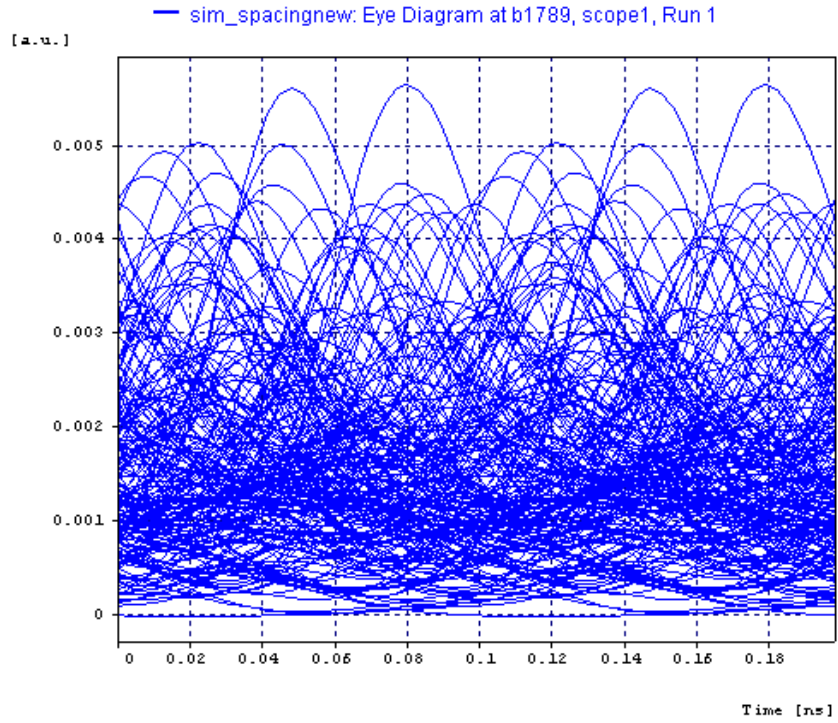
Figure 3.7 represents the variation of eye opening with the channel spacing. The graph shows that eye opening decreases on increasing the spacing between the input channels.

Figure 3.8 shows the eye diagrams for the various values of channel spacing. Figure 3.8 (a) shows the eye diagram for 6.25 GHz spacing. Figure 3.8 (b) shows the eye diagram for 10 GHz spacing. Figure 3.8 (c) shows the eye diagram for 20 GHz spacing. Figure 3.8 (d) shows the eye diagram for 75 GHz spacing.

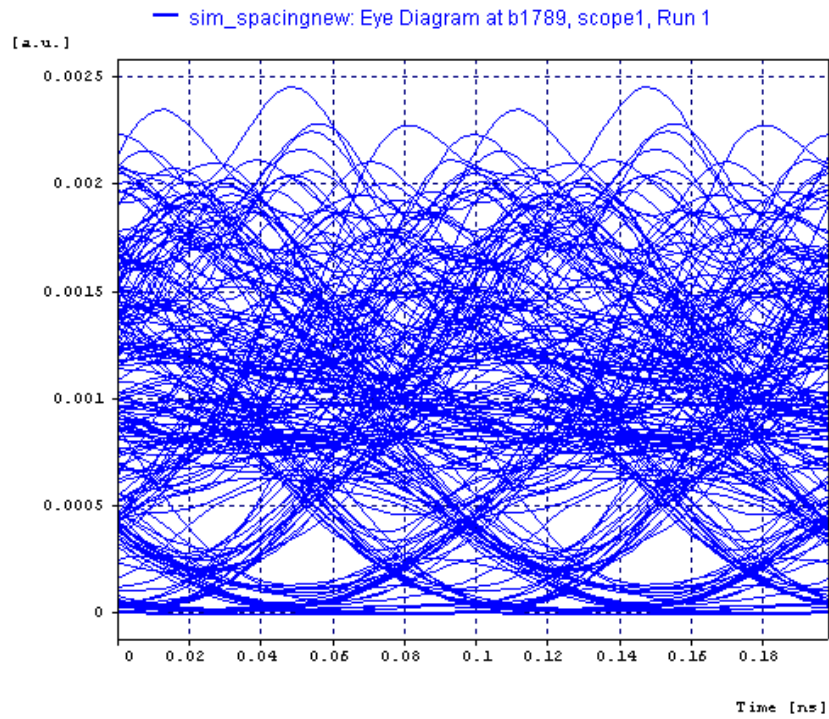


**Figure 3.8 (a)** Eye diagram for 6.25 GHz spacing

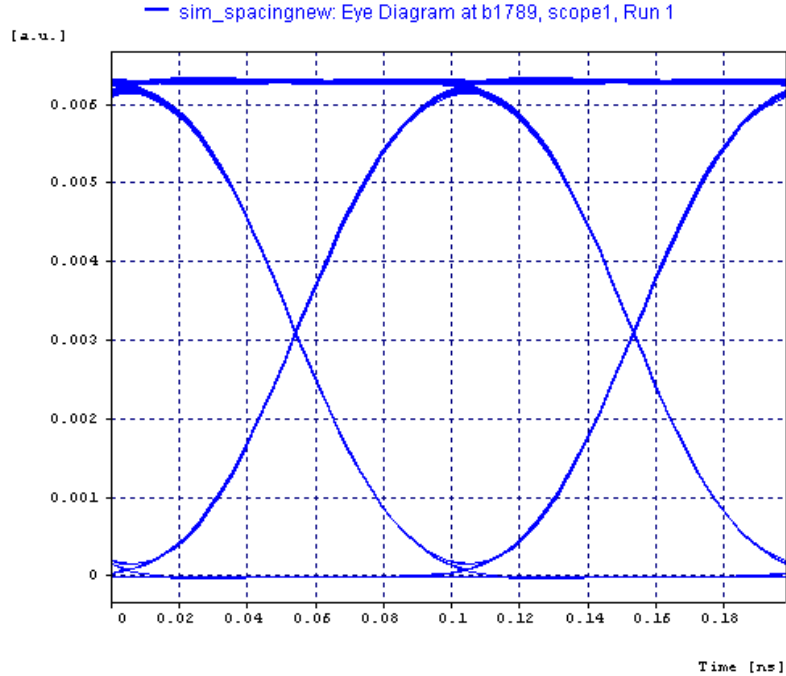
The above eye diagram shows that there is large interference between the input frequencies. The BER is quite large at 6.25 GHz. Thus, four wave mixing is quite large when the spacing between the input channels is 6.25 GHz.



**Figure 3.8 (b)** Eye diagram for 10 GHz spacing



**Figure 3.8 (c)** Eye diagram for 20 GHz spacing



**Figure 3.8 (d)** Eye diagram for 75 GHz spacing

The above eye diagrams show that the eye diagram clarity goes on increasing with the increasing spacing between the input channels. This shows that the interference between the input frequencies and hence the four wave mixing effect decreases with the increasing channel spacing.

### 3.5 CONCLUSION

In this chapter, the design, implementation and performance analysis of four wave mixing in optical communication system for different values of spacing between input channels is presented. The comparison of four wave mixing effect at various values of channel spacing revealed that 75 GHz spacing has the edge over 6.25 GHz spacing in optical communication system. It is found that spacing of 75 GHz has the lowest BER and better system performance. Hence, the higher spacing values between the input channels is recommended for long distance transmission without four wave mixing. It can be seen from the graphs of BER, Q-factor and eye opening that higher channel spacing gives the best performance as compared to lower channel spacing. Hence, it is concluded that higher channel spacing is best suitable to be employed in the optical communication systems minimizing the four wave mixing effect.

## CHAPTER 4

# DESIGN AND PERFORMANCE ANALYSIS OF FOUR WAVE MIXING EFFECT WITH DIFFERENT OPTICAL TRANSMITTER COMPONENTS

---

In this chapter, the design, implementation and performance analysis of four wave mixing in optical communication system on changing the different transmitter components in the circuit is presented. Various methods are used to minimize the four wave mixing effect at the output. The extent of four wave mixing is considered for each and every component separately. Components involve different data sources like pn-sequence generator with different bit rate; modulator drivers like NRZ and RZ raised cosine, NRZ and RZ rectangular, RZ supergaussian, RZ soliton; modulators like linear amplitude, linear electroabsorption and optical phase modulator; laser with different power values. After that the four wave mixing effect has been compared for all these components in terms of output spectrums, BER, Q-factor and eye opening. The simulation results revealed that four wave mixing effect remains same on changing the bit rate of the data source. Four wave mixing is minimum when NRZ raised cosine modulator driver is used. Also, FWM effect reduces to least extent when linear amplitude modulator is used and it becomes the most when linear electroabsorption modulator is used. Moreover, the Q-factor and eye opening increases with increasing laser power. The BER is minimum at higher values of laser power.

### 4.1 INTRODUCTION

As new applications for telecommunications mature, such as multimedia services, and the world wide web, greater demand is being placed on the bandwidth of the existing telecommunications systems. Single-mode fiber installed around the world has the capacity of many Tb/s.

Commercial high-speed systems operate in the range of 2.5–10 Gb/s, thus leaving much room for more efficient use of the available fiber bandwidth [31]. Increasing the channel bit rate beyond current levels will prove to be increasingly difficult since the cost of the supporting electronics increases and the achievable transmission distance decreases due to fiber dispersion. Consequently, a world-wide consensus is driving the utilization of wavelength-division multiplexing (WDM) technologies for a more effective use of the available fiber bandwidth [32]. An important element for implementation of WDM systems is a wavelength converter [33, 34]. Many technologies exist for the implementation of wavelength conversion [35]. Optoelectronic, cross-gain saturation [36], and cross-phase saturation [37] wavelength converters are candidate technologies that offer excellent performance; however, they are not transparent to modulation format [38]. Complete or so-called strict transparency is offered only by ultra-fast wave mixing techniques based on either four-wave mixing (FWM) or difference frequency generation [39]. The performance of difference frequency generation has made impressive strides in recent years through use of quasi-phase matching in AlGaAs waveguides [40]. However, the use of quasi-phase matched waveguides mandates a fixed pump wavelength. This, in turn, means that a given input wavelength can be mapped to only one converted wavelength. On the other hand, FWM in semiconductor optical amplifiers (SOA's) [41] is insensitive to phase matching, offering arbitrary wavelength mapping.

The FWM power generated at the end of the fiber due to interaction of channels at frequencies,  $f_i$ ,  $f_j$  and  $f_k$  is given by

$$P_{\text{FWM}} = ((1024 \pi^6)/(n^4 \lambda^2 c^2)) [D\chi]^2 ((P_i P_j P_k)/(A_{\text{eff}}^2)) L_{\text{eff}}^2 \eta e^{-\alpha L}$$

where  $P_i$ ,  $P_j$  and  $P_k$ , refer to the soliton input powers at frequency  $f_i$ ,  $f_j$  and  $f_k$  respectively,  $n$  is the fiber effective refractive index,  $\lambda$  is the zero dispersion wavelength,  $c$  is the velocity of light,  $\chi$  is the 3rd order nonlinear susceptibility of the single mode fiber,  $A_{\text{eff}}$  is the effective mode area of the fiber,  $L_{\text{eff}}$  is the fiber effective length,  $\alpha$  is fiber attenuation coefficient and  $D$  is the degeneracy factor, where  $D = 6$  for  $i = j$  and  $D = 3$  for  $i \neq j$ .

The FWM light generation efficiency is given by

$$\eta = (\alpha^2 / (M^2 (\alpha^2 + \Delta\beta^2))) ((\sin^2 (M \Delta\beta L_{a/2})) / (\sin (\Delta\beta L_{a/2}))) \cdot (1 + (4 \exp(-\alpha L_a) \sin^2 (\Delta\beta L_{a/2})) / (1 - \exp(-\alpha L_a))^2)$$

where M refers to the number of fiber sections and  $\Delta\beta$ , the phase mismatching constant, in general, can be written as  $\Delta\beta = \beta(f_i) + \beta(f_j) - \beta(f_k) - \beta(f_{\text{FWM}})$  where  $\beta$  represents the propagation constant [24].

Yutaka Miyamoto et. al. [8] described recent technical challenges and the progress towards the realization of the optical transport network based on 43 Gb/s channel. They proposed 43-Gb/s/ch dense wavelength-division multiplexing (DWDM) dispersion-managed transmission system using carrier-suppressed return-to-zero (CS-RZ) format.

Takehiro Tsuritani et. al. [9] investigated ultra-long-haul 42.7-Gbit/s-based dense wavelength-division multiplexing (DWDM) transmission using optically prefiltered carrier-suppressed return-to-zero signal. They experimentally investigated the optimum filtering condition for 65- or 45-GHz-wide prefiltered CS-RZ signals in the ultra-long-haul DWDM transmission and conducted the 70- and 50-GHz spaced 32 x 42.7 Gbit/s transmission using prefiltered CS-RZ signals.

Masahiro Daikoku et. al. [11] conducted single-polarization 160Gbit/s-based field transmission experiments. They achieved single-channel transmission and 8 WDM transmission with 300GHz channel spacing over the inter-city 200km SMF by utilizing 160Gbit/s RZ-DPSK signals and a simple PMD compensator.

Lara D. Garrett et. al. [12] demonstrated a bidirectional transmission system with 16 10-Gb/s dense wavelength-division-multiplexing channels on 32 wavelengths over 5000 km of nonzero dispersion-shifted fiber in a fully bidirectional recirculating loop, for a full-duplex capacity-distance product of 800 Tb/s/km.

L. H. Spiekman et. al. [13] modulated eight DWDM channels in the wavelength region 1558-1570 nm, spaced at 200 GHz at 20 Gb/s and transmitted over 160 km using four in-line SOA's.

Up till now, various methods to reduce four wave mixing effect have been proposed and theoretically compared but the comparison on the basis of different components is rarely considered. In this chapter, four wave mixing effect is compared on changing the different components like data sources; modulators as linear amplitude, linear electroabsorption, phase modulator; modulator drivers like NRZ and RZ raised cosine, NRZ and RZ rectangular, RZ super gaussian, RZ soliton.

This chapter is divided into different sections. In the first section, the introduction of four wave mixing effect is presented. In the second section, the schematic model is proposed. The third section describes the simulation setup for an optical communication system implementing these requirements. In the fourth section, the comparison of four wave mixing on the basis of different components is done in terms of output spectrums. The fifth section gives the conclusion of this chapter.

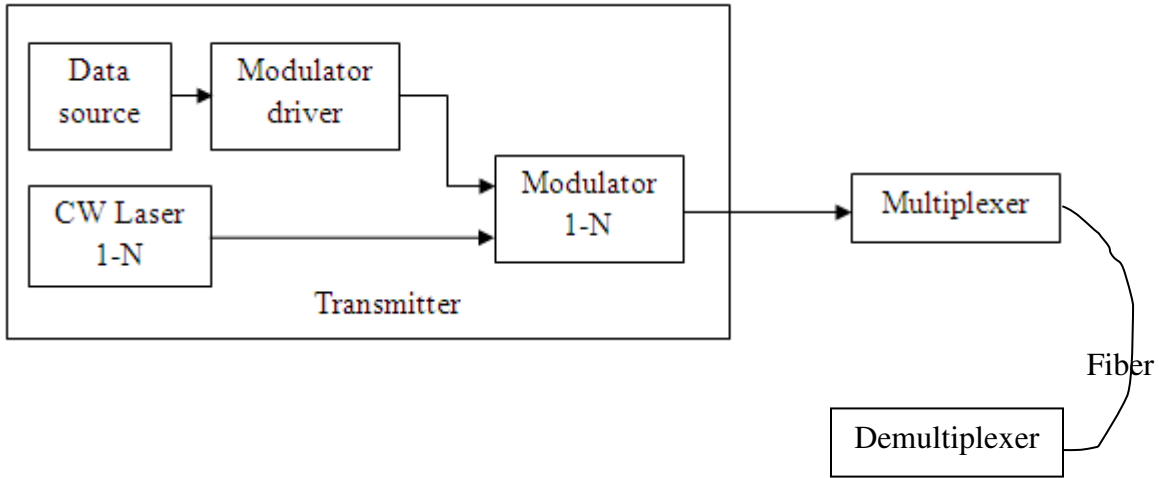
## **4.2 SCHEMATIC MODEL**

The schematic model for an optical communication system implementing the four wave mixing effect for different components is presented in figure 4.1. N input channels/users are taken in this case for reference. The number of users can vary depending on various constraints like the bandwidth range. The four wave mixing effect is considered till the end of the fiber. The receiver section is not considered in this case.

This schematic model is the general setup for an optical communication system in which non linear fiber is installed which adds non linearities like four wave mixing. The post-amplifier, in-line amplifier and pre-amplifier are used in case of long transmission distances.

The transmitter section consists of a laser, modulator driver, pn-sequence generator i.e. data source; and a modulator. The wavelength of various channels is set by keeping the difference equal to the spacing required. Then all these transmitted signals are combined/multiplexed together. Then the combined signal is amplified so that it can be transmitted over long distances without its degradation. Then the signal is transmitted over the non linear fiber which adds the

non linearities into the signal. Then the optical spectrum is observed by attaching an optical probe at the output of the demultiplexer.

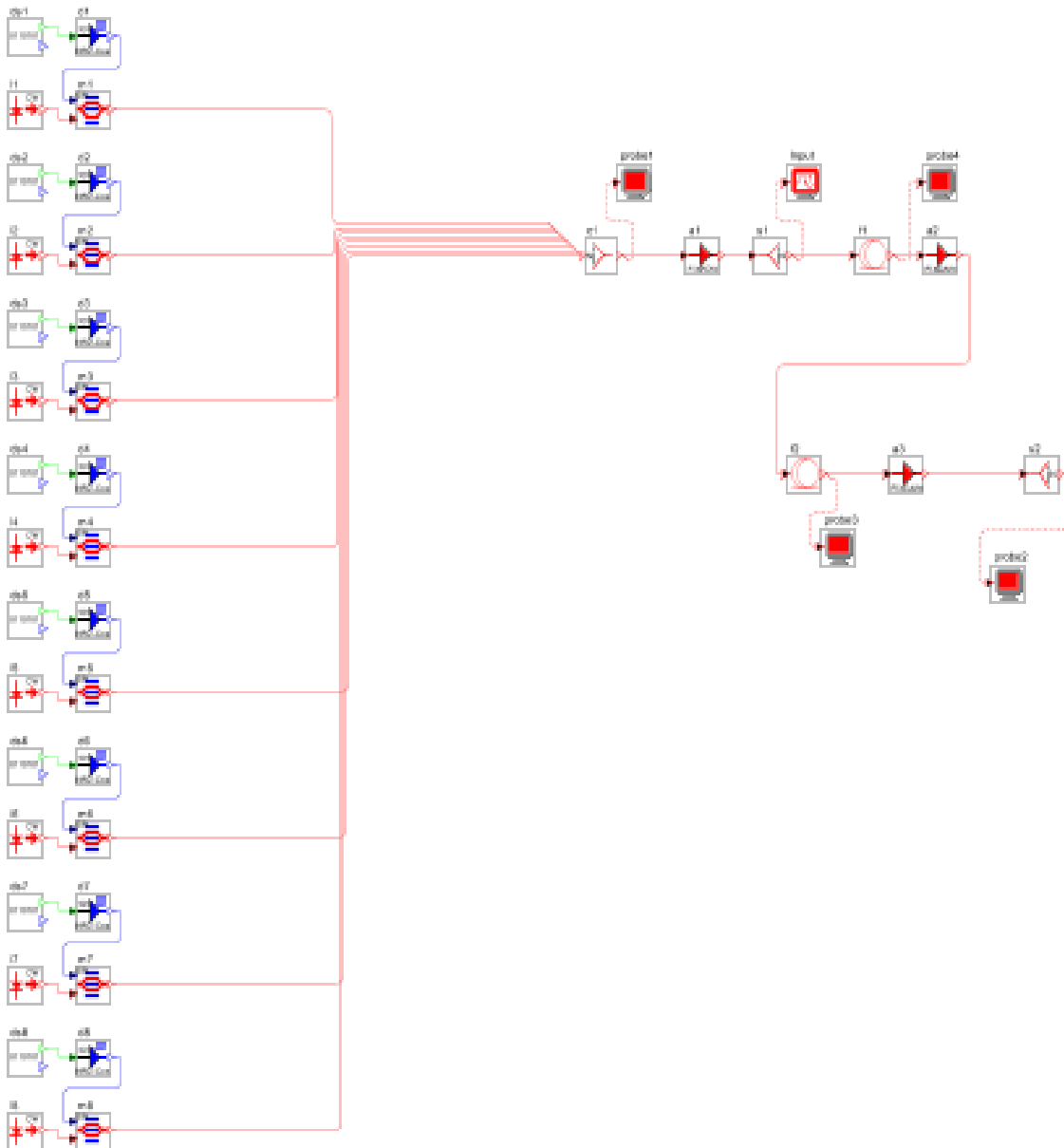


**Figure 4.1** Schematic model

### 4.3 SIMULATION SETUP

The simulation setup for showing the effect of changing the different components on four wave mixing is shown in figure 4.2. The continuous wave laser (L1-L8) in the transmitter section is used to create the carrier signal. In this setup, eight users are taken in account whose wavelengths have a specific difference i.e. spacing between them. The wavelength of first user is kept at 192.98 nm. The wavelengths of next users is set as per the spacing requirement i.e. at frequency difference of 20 GHz. The data source (ds1-ds8) is used to generate the random input data bit sequence at the bit rate of 10 Gbps in one case and 20 Gbps in the other. The light signal modulates the input data. The modulator (m1-m8) is driven by the modulator driver (d1-d8) which decides the input data format. The input data format used in this setup is NRZ raised cosine. The modulated data from all the users is combined using a combiner (c1). The post amplifier (a1) amplifies the signal before allowing it to enter into the fiber to avoid losses. Then this signal is sent over the fiber (f1) of length 100 Km. All the attenuation, dispersion and non linear effects are activated. The in-line amplifier (a2) amplifies the signal in the transmission medium itself. Then the signal is again passed through a fiber (f2) of length 100 km. Then pre-amplifier (a3) is used to amplify the signal before allowing it to enter into the receiver section.

After amplification, the signal reaches the demultiplexer. The signal is demultiplexed by using a splitter (s1) which splits this signal into the same number of signals as were transmitted. An optical scope (probe1) is attached at the output of combiner to examine the input signal. Another optical scope (probe2) is placed at the output of splitter to examine the four wave mixing effect in frequency spectrum.



**Figure 4.2** Simulation setup

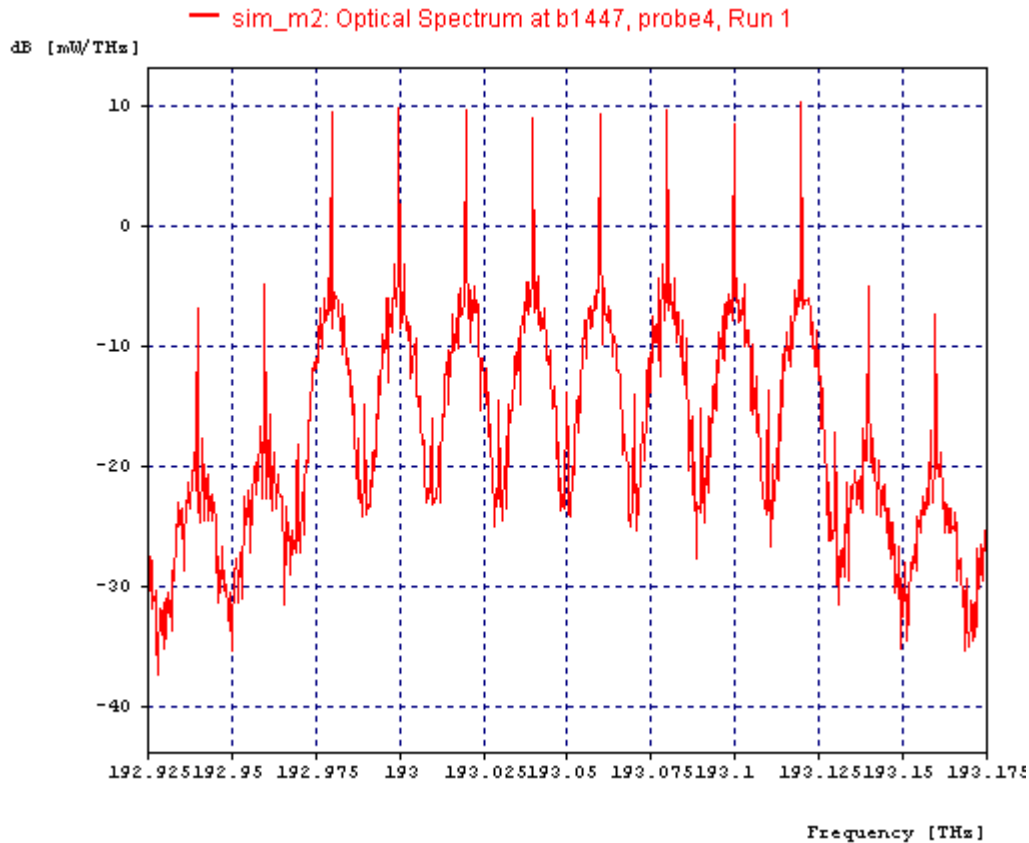
## 4.4 RESULTS AND DISCUSSION

Using simulation setup, the optical spectrums are observed. Optical scope measures the input and output frequency spectrums.

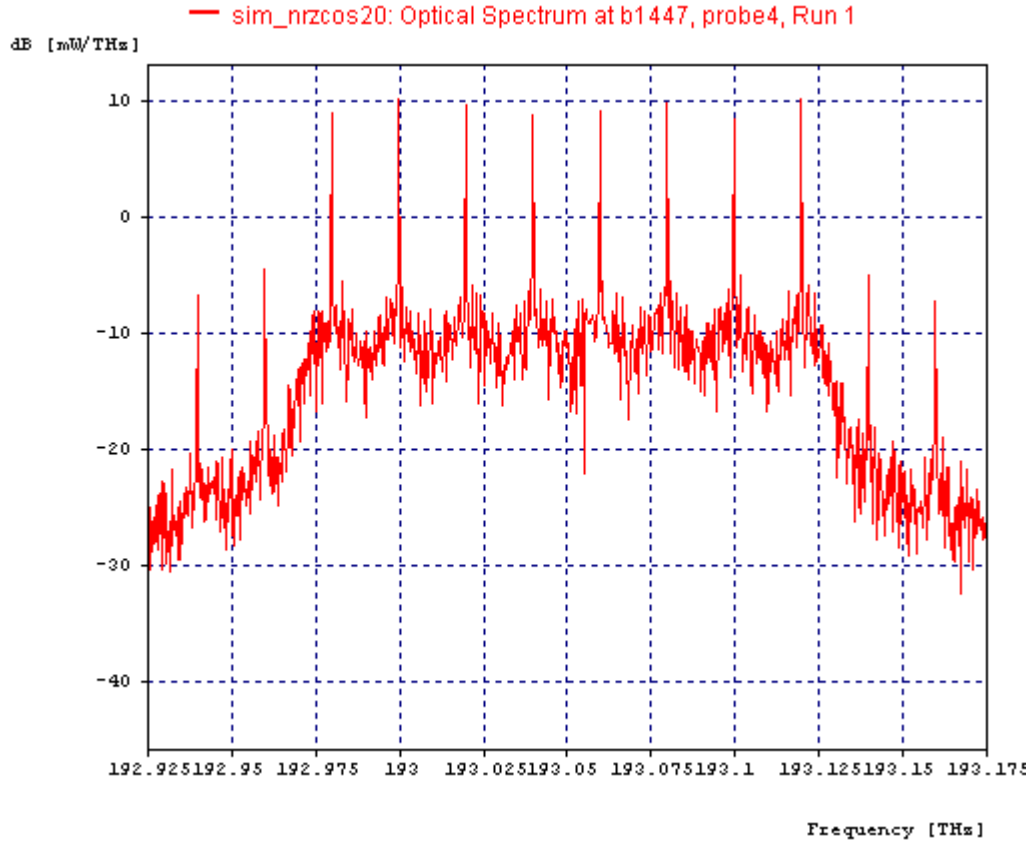
Figure 3.3 shows the input optical spectrum for the channel spacing of 20 GHz when 8 input channels are taken. On changing the spacing between the different users, the peaks get shifted to the frequencies as specified in the laser. The analysis is done on the optical spectrums in this case.

### 4.4.1 Effect of changing bit rate of data source

Figure 4.3 shows the output spectrums for the different bit rates of data source.



**Figure 4.3 (a)** Bit rate 10 Gbps



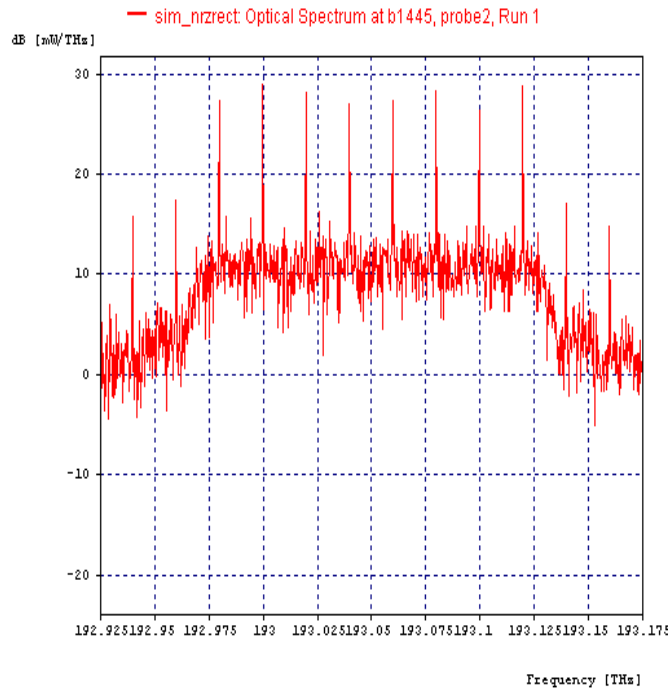
**Figure 4.3 (b)** Bit rate 20 Gbps

The above optical spectrums shows the effect of different bit rates of the data source on the four wave mixing at the output. These spectrums reveal that there is no effect of changing the bit rate of the data source on the four wave mixing. The FWM effect remains the same on varying bit rates of the data source.

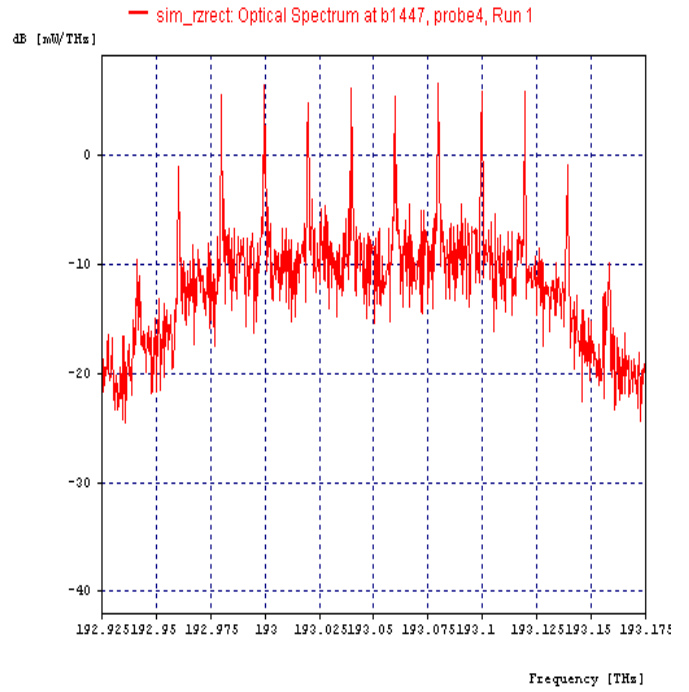
#### 4.4.2 Effect of changing modulator drivers

Figure 4.4 shows the effect of changing modulator drivers on the four wave mixing at the output. Different modulator drivers whose effect is taken in this chapter are NRZ raised cosine, NRZ rectangular, RZ rectangular, RZ raised cosine, RZ super gaussian, RZ soliton.

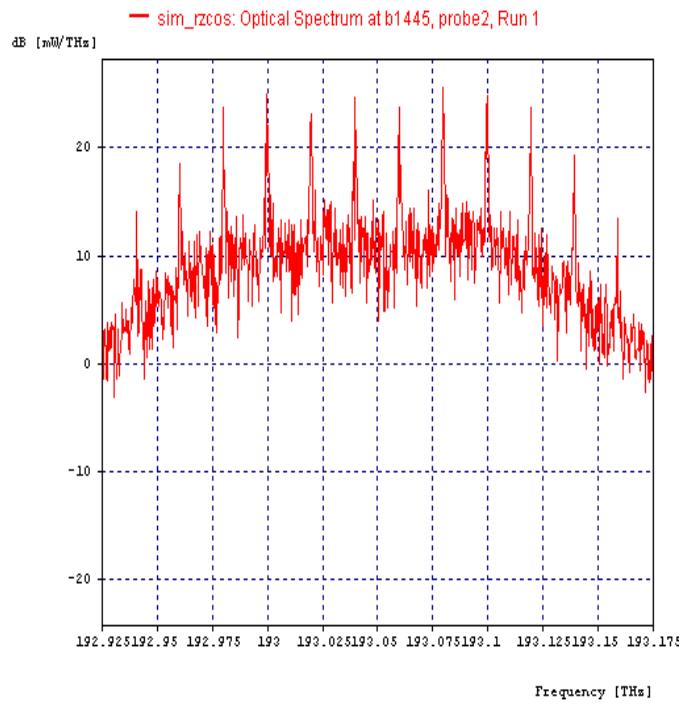
The output optical spectrum for NRZ raised cosine modulator driver is shown in figure 4.3 (a). The optical spectrum of other modulator drivers are presented as follows.



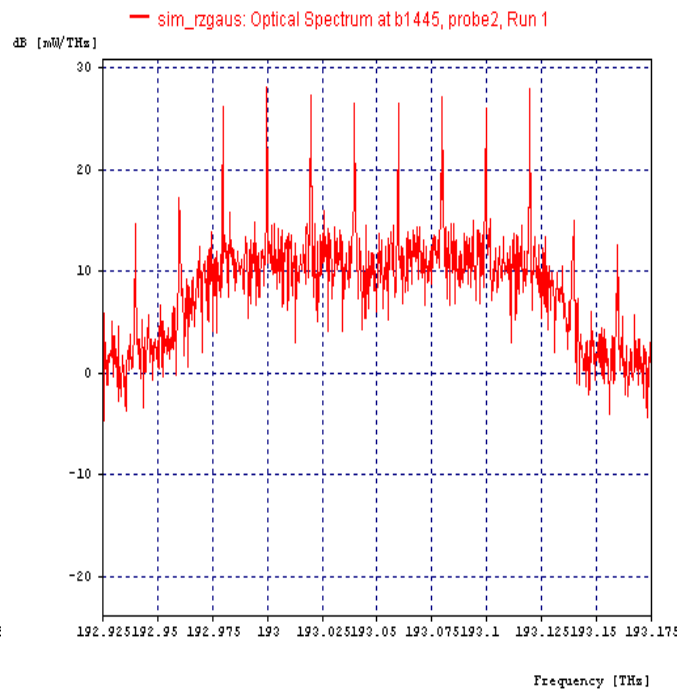
**Figure 4.4 (a)**



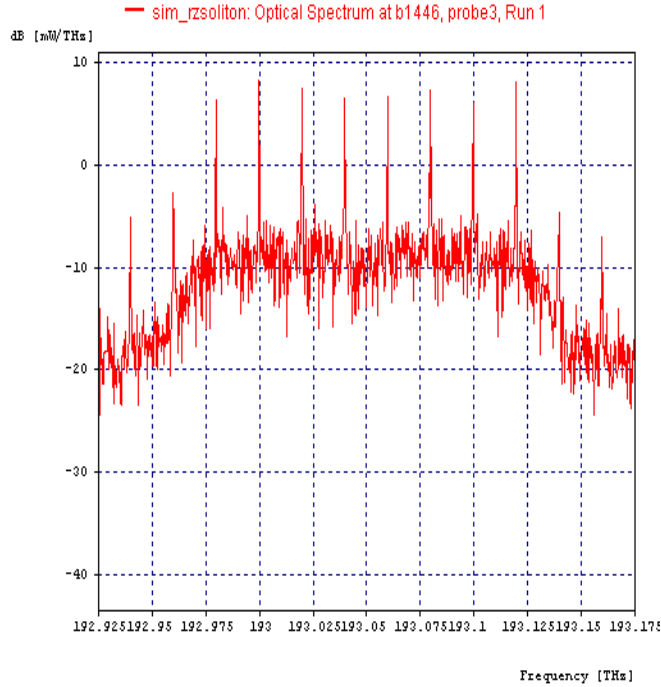
**Figure 4.4 (b)**



**Figure 4.4 (c)**



**Figure 4.4 (d)**



**Figure 4.4 (e)**

Figure 4.4 (a) represents the NRZ rectangular modulator driver. Figure 4.4 (b) represents the RZ rectangular modulator driver. Figure 4.4 (c) represents the RZ raised cosine modulator driver. Figure 4.4 (d) represents the RZ super gaussian modulator driver. Figure 4.4 (e) represents the RZ soliton modulator driver.

From the above output optical spectrums, it is clear that changing the modulator drivers least effect the four wave mixing occurring in the communication channel. NRZ raised cosine modulator driver gives the output much clear than all other modulator driver. Hence, it can be concluded that four wave mixing is minimum when NRZ raised cosine modulator driver is used.

#### **4.4.3 Effect of changing modulators**

Figure 4.5 represents the effect of changing modulators on the four wave mixing at the output. The different modulators taken in account are linear amplitude modulator, linear electroabsorption modulator and optical phase modulator.

The output optical spectrums of these modulators are presented below.

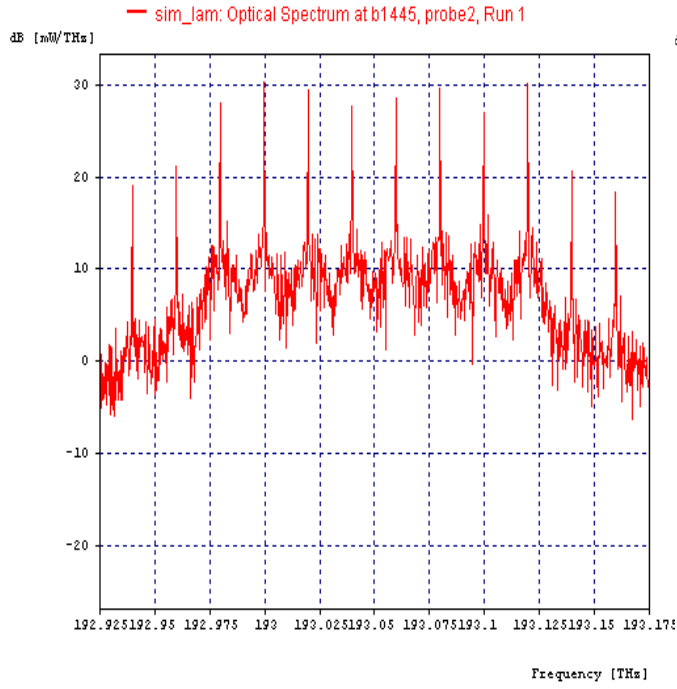


Figure 4.5 (a)

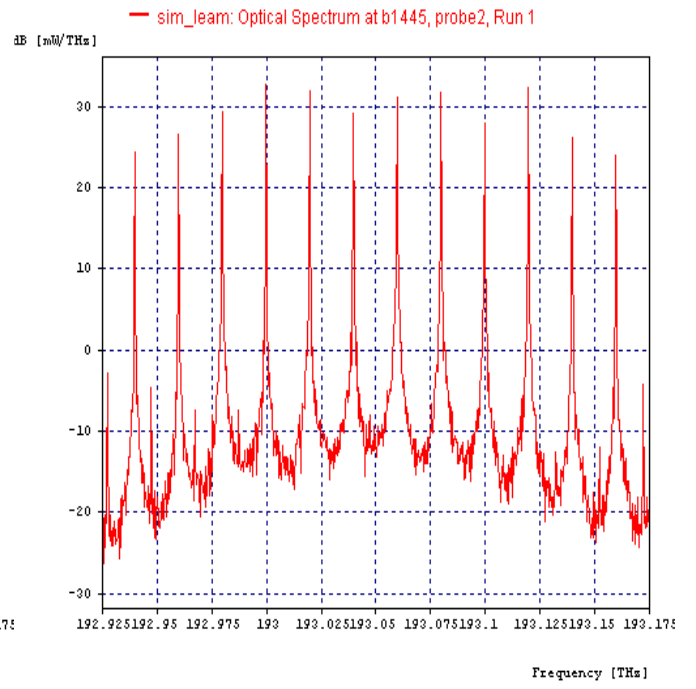


Figure 4.5 (b)

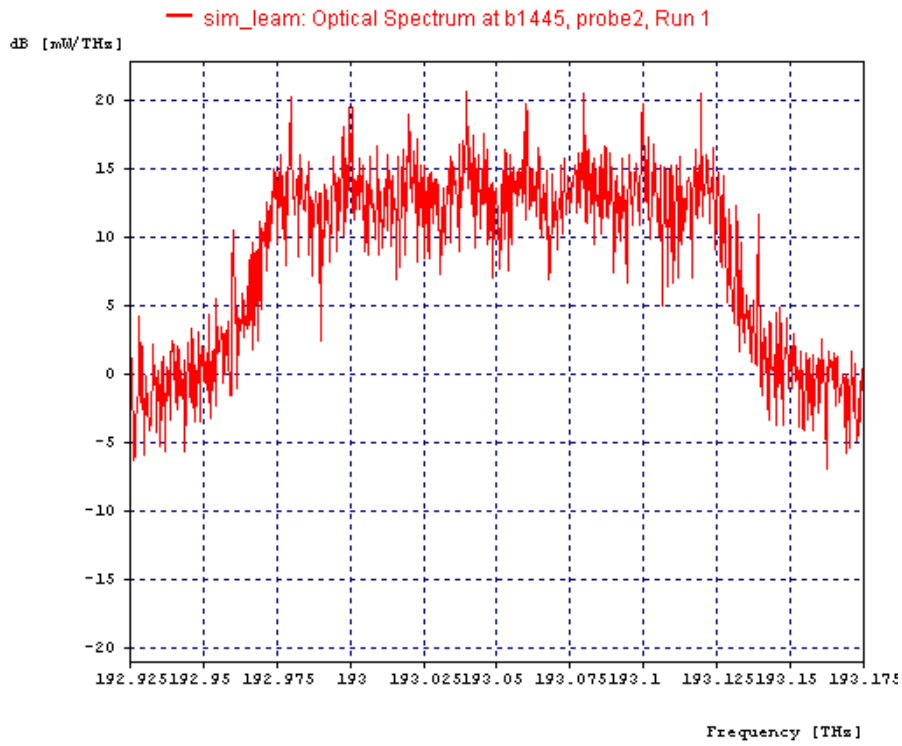


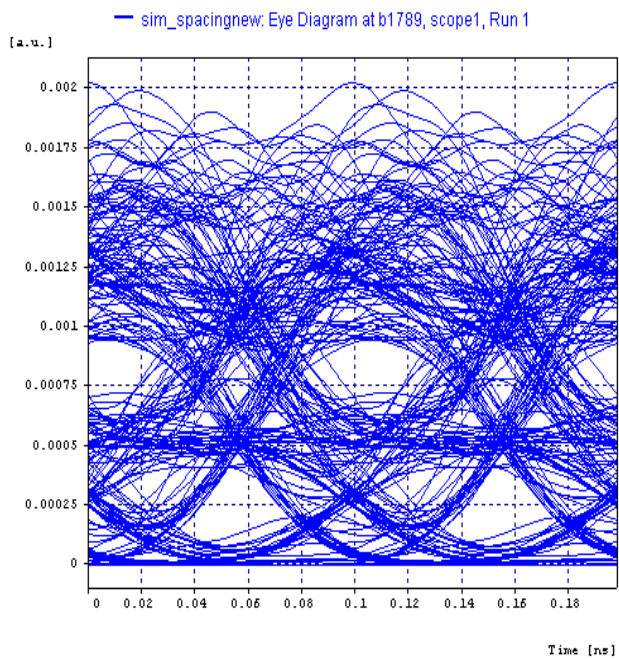
Figure 4.5 (c)

Figure 4.5 (a) represents the output optical spectrum for linear amplitude modulator. Figure 4.5 (b) represents the output optical spectrum for linear electroabsorption modulator. Figure 4.5 (c) represents the output optical spectrum for optical phase modulator.

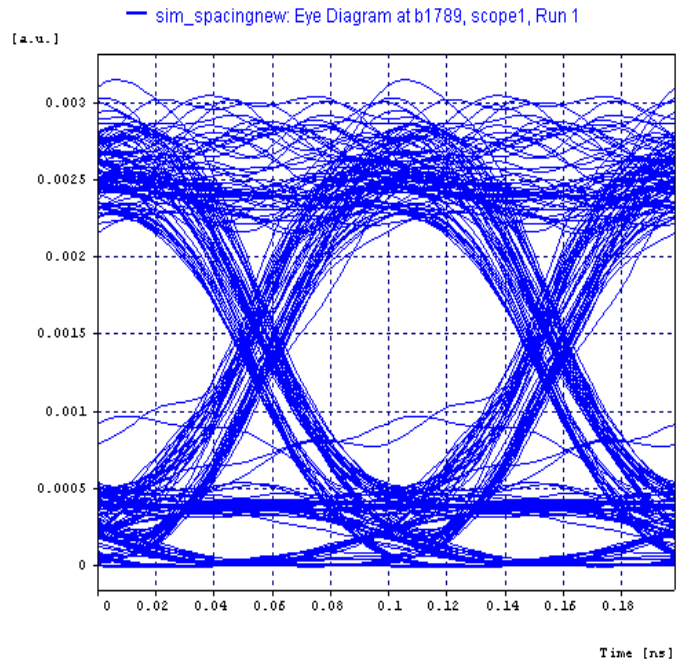
The above optical spectrums reveal that four wave mixing is minimum when linear amplitude modulator is used and is maximum when optical phase modulator is used. The linear amplitude modulator gives the best performance. Thus, to reduce the four wave mixing, linear amplitude modulator should be used.

#### 4.4.4 Effect of changing power of Continuous Wave Lasers

Figure 4.6 represents the effect of changing the laser power. The channel spacing is kept at 25GHz. The different power values taken for comparison are -10 dB, -5 dB, 0 dB, 5 dB and 10 dB. The comparison is done on the basis of eye diagrams shown as below.

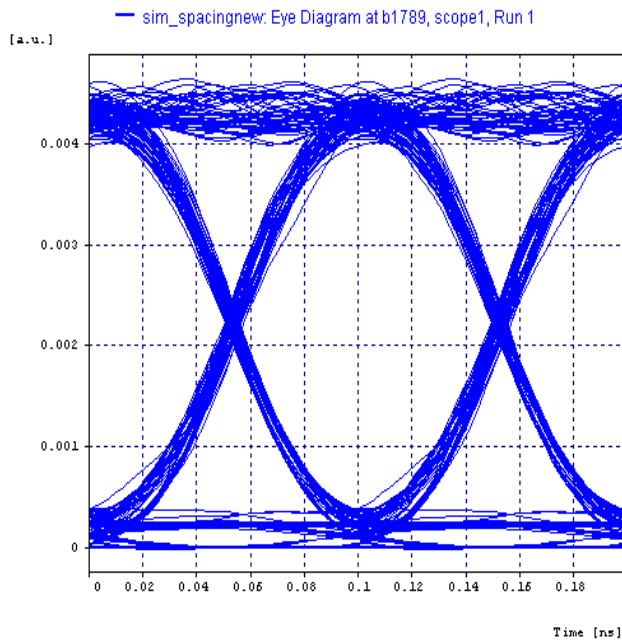


**Figure 4.6 (a)**

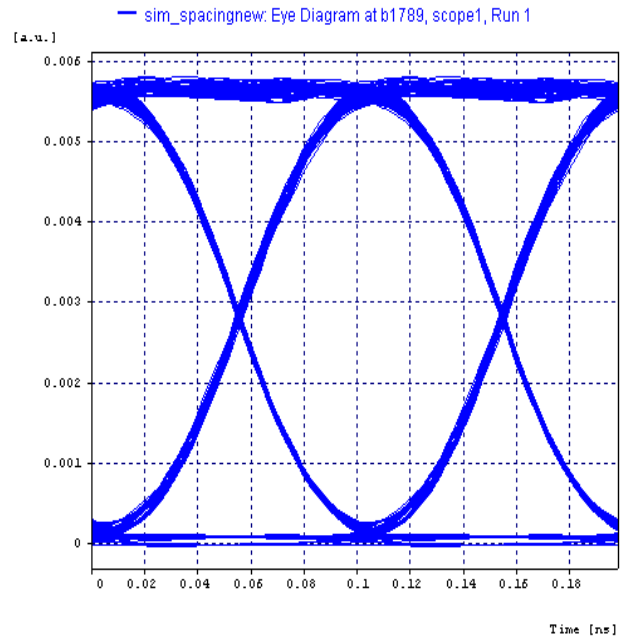


**Figure 4.6 (b)**

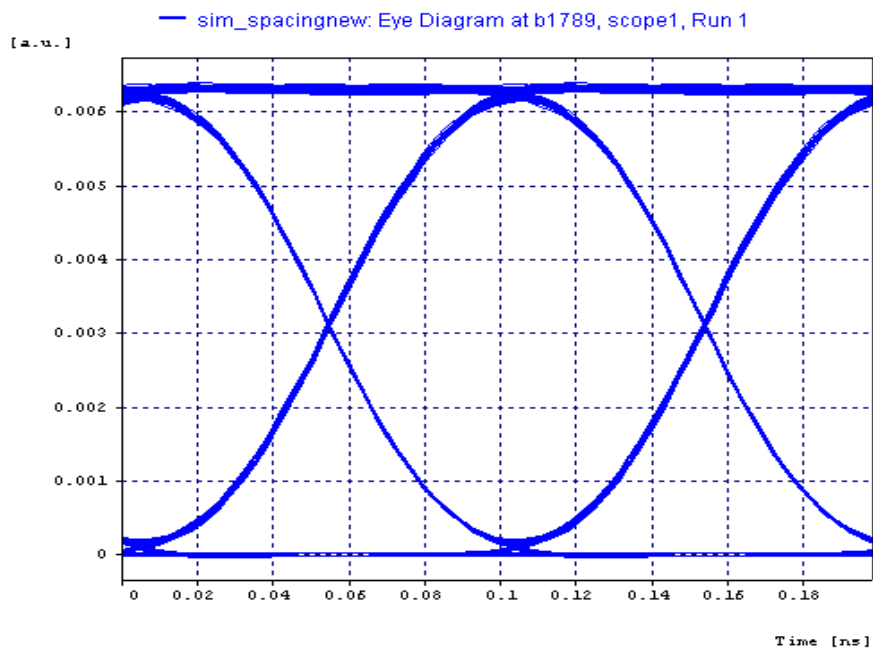
Figure 4.6 (a) shows the eye diagram for power of -10 dB. Figure 4.6 (b) shows the eye diagram for power of -5 dB. Figure 4.6 (c) shows the eye diagram for power of 0 dB. Figure 4.6 (d) shows the eye diagram for power of 5 dB. Figure 4.6 (e) shows the eye diagram for power of 10 dB.



**Figure 4.6 (c)**



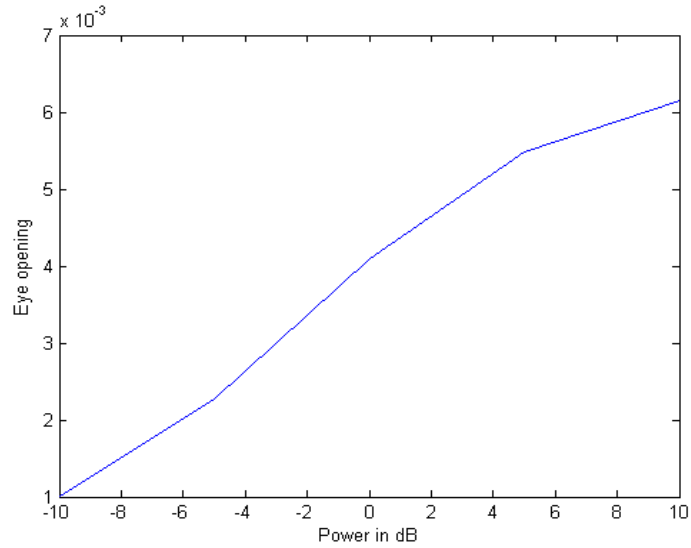
**Figure 4.6 (d)**



**Figure 4.6 (e)**

The above eye diagrams reveal that on increasing the power level of the laser in the transmitter section, the four wave mixing effect decreases. This is more clear from the following graphs.

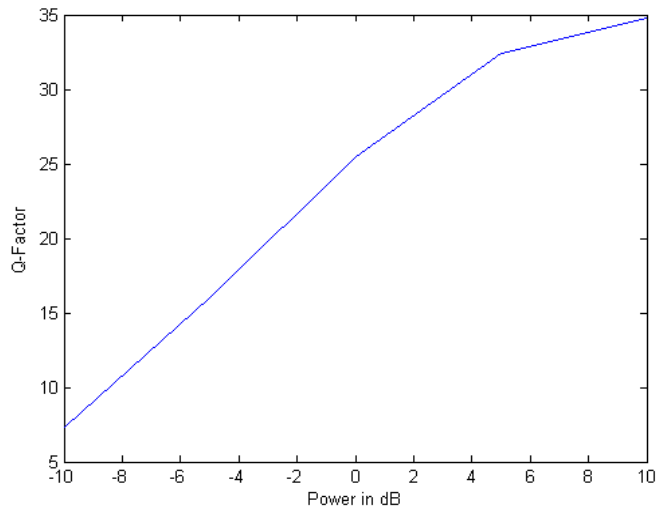
Figure 4.7 shows the variation of eye opening with respect to the power levels of input laser at channel spacing of 25 GHz.



**Figure 4.7** Variation of Eye opening with respect to laser power

The above graph shows that with the increasing laser power, the eye opening increases.

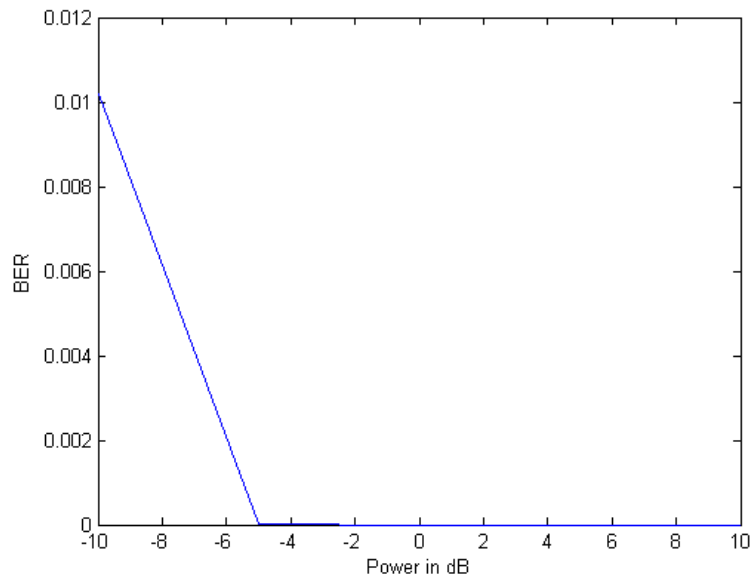
Figure 4.8 represents the variation of Q-factor with respect to the laser power at channel spacing of 25 GHz.



**Figure 4.8** Variation of Q-factor with respect to laser power

The graph shows that on increasing the laser power, the Q-factor increases. At lower values of laser power, the Q-factor is very small but on increasing the laser power, the Q-factor increases.

Figure 4.9 shows the variation of BER with respect to laser power at channel spacing of 25 GHz.



**Figure 4.9** Variation of BER with respect to laser power

The graph reveals that as the laser power increases, the bit error rate decreases.

#### 4.5 CONCLUSION

In this chapter, the design, implementation and performance analysis of four wave mixing in optical communication system for different components is presented. The extent of four wave mixing is considered for each and every component separately. The comparison of four wave mixing with different components revealed that changing the bit rate of data source doesnot effect the four wave mixing at the output. Changing the modulator drivers least effects the four wave mixing. NRZ raised cosine modulator driver gives the least four wave mixing. On changing the modulator, the four wave mixing is largely effected. The linear amplitude modulator gives the best system performance and the optical phase modulator gives the worst performance among all the modulators. Hence, it is concluded that linear amplitude modulator is

best suitable to be employed in the optical communication system minimizing the four wave mixing effect. Also, the eye opening and the Q-factor increases on increasing the laser power. Moreover, the bit error rate is minimum when the power level of laser is maximum.

# CHAPTER 5

## INVESTIGATION OF FWM EFFECT WITH DIFFERENT NUMBER OF INPUT CHANNELS AT VARIOUS CHANNEL SPACINGS

---

In this chapter, the design and implementation and performance analysis of four wave mixing in optical communication system for different number of input channels at various values of channel spacing is presented. Various methods have been developed to reduce the non linear effects like four wave mixing at the output. Here, all the input channels are spaced evenly at various values like 6.25 GHz, 12.5 GHz, 25 GHz, 40 GHz, 50 GHz with the different number of channels at the input i.e. with 2, 4, 6, 8, 12 input channels. After this, the effect of four wave mixing has been analyzed for each channel spacing with these number of channels in terms of eye diagrams, BER, eye opening and Q-factor. The simulation results revealed that the four wave mixing is minimum when the channel spacing is maximum i.e. 50 GHz and the number of channels is minimum i.e. 2 input channels. It has been observed that on increasing the channel spacing, the interference between the input frequencies decreases and hence the four wave mixing also decreases. Also, on increasing the number of input channels/users, the interference between the input frequencies increases and thus, the four wave mixing also increases.

### **5.1 INTRODUCTION**

As broad-band Internet access is rapidly penetrating world markets and homes, Internet traffic is increasing rapidly in the core network. Associated with the expansion of Broad-band is the paradigm shift in telecommunications from voice-optimized to IP centric networks [42]. Optical networks have been considered as the only means to ensure delivery of large capacity links in a flexible, dynamic and reliable way [43]. Optical transparent networks have attracted much attention as a potential solution to the future capacity and flexibility requirements in optical communication systems. There are several key components required to realize fully transparent

optical networks: optical switches, optical add-drop multiplexers and wavelength converters to mention a few [44]. Dense Wavelength Division Multiplexing (DWDM) is a fiber optic transmission technique that employs light wavelengths to transmit multiple data signals [45] and so, to make an effective usage of the fiber bandwidth and achieve high system capacity [46]. To improve system performance, understanding nonlinear optical effects in long haul transmission systems, such as DWDM systems is important. Optical fiber nonlinearities can lead to interference, distortion, and excess attenuation of the optical signals, resulting in performance degradation. The most common nonlinear optical effect of importance in optical fiber communication systems results from the fiber nonlinear refractive index. The nonlinearity in the refractive index is known as Kerr nonlinearities. The Kerr nonlinearity gives rise to different effects, such as self-phase modulation (SPM), cross-phase modulation (XPM), and four-wave mixing (FWM) [18]. FWM may induce lightpath BER fluctuations in dynamic networks that can affect the optical signal to noise ratio and quality of service in transparent networks under highly complex nonlinear effect [19] and influence the frequency chirp and extinction ratio in the system [20]. Four-wave mixing (FWM) is one of the dominating degradation effects in wavelength-division-multiplexing (WDM) systems with dense channel spacing and low chromatic dispersion on the fiber. If in a WDM system the channels are equally spaced, the new waves generated by FWM will fall at channel frequencies and, thus, will give rise to crosstalk. In case of full in-line dispersion compensation, i.e., 100% dispersion compensation per span, the FWM crosstalk becomes of a maximum level since the FWM products add coherently in each span [20]. Four-wave mixing (FWM) is a parametric process in which different frequencies interact and by frequency mixing generate new spectral components [10]. The magnitude of FWM efficiency depends on channel power, channel spacing and fiber dispersion but is independent of the bit rate [15]. In the transmission of dense wavelength-division multiplexed (DWDM) signals, FWM is to be avoided, but for certain applications, it provides an effective technological basis for fiber-optic devices. FWM also provides the basic technology for measuring the nonlinearity and chromatic dispersion of optical fibers. FWM has proved useful in such applications as realtime holography, supercontinuum generation, and soliton communication systems [47]. The most common configuration involves a self-focusing nonlinearity and a backward geometry, in which the initial pump beams counterpropagate to create a reflection grating.

Hwang and Tonguz et. al. [9] described the comparisons of power penalty due to FWM between equal channel spacing and the unequal channel spacing for the 20-channel WDM system. They show that for an intensity modulation/direct detection transmission system operating in an optical bandwidth of 16 nm with 0 dBm (1mW) peak optical input power per channel achieve BER  $\frac{1}{4} 10^{-9}$  with an FWM cross-talk power of less than 1 dB, which was not achieved by a conventional equal channel spacing WDM system with 0.84 nm channel spacing.

Masahiro Daikoku et. al. [11] conducted single-polarization 160Gbit/s-based field transmission experiments. They achieved single-channel transmission and 8 WDM transmission with 300GHz channel spacing over the inter-city 200km SMF by utilizing 160Gbit/s RZ-DPSK signals and a simple PMD compensator.

Lara D. Garrett et. al. [12] demonstrated a bidirectional transmission system with 16 10-Gb/s dense wavelength-division-multiplexing channels on 32 wavelengths over 5000 km of nonzero dispersion-shifted fiber in a fully bidirectional recirculating loop, for a full-duplex capacity-distance product of 800 Tb/s/km.

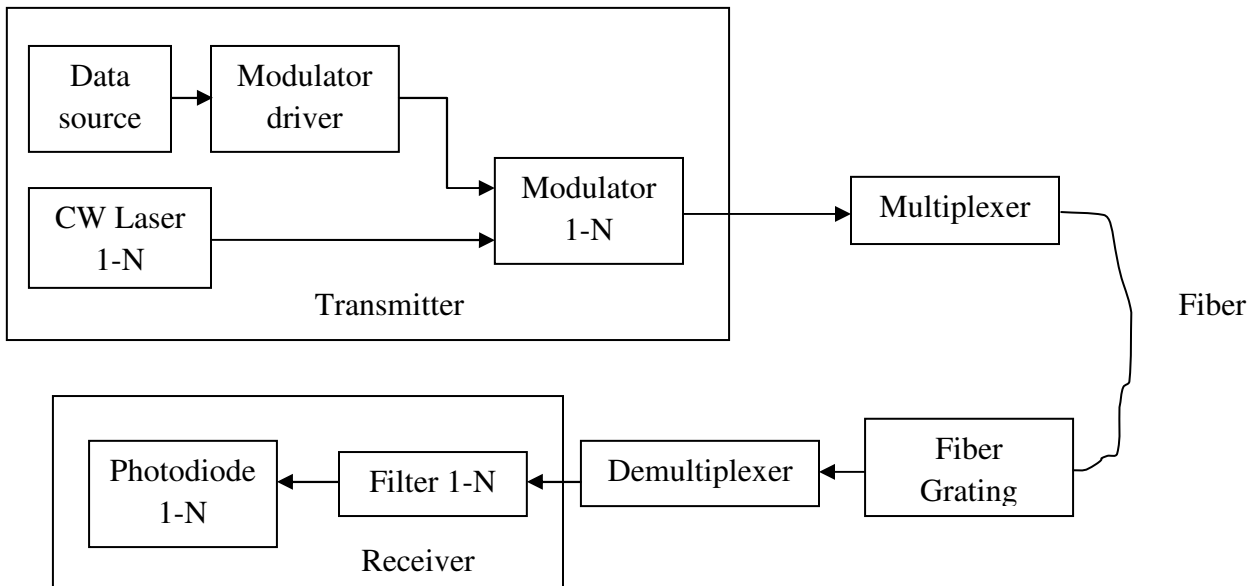
C. A. Brackett et. al. [34] presented an architectural approach for very-high-capacity wide-area optical networks, and described a proposed program of research to address key system and device issues. The network was based on dense multi-wavelength technology and was scalable in terms of the number of networked users, the geographical range of coverage, and the aggregate network capacity. They employed a distributed optical interconnect that is wavelength-selective and electronically controllable, permitting the same limited set of wavelengths to be reused among other access stations.

Up till now, many methods have been proposed to reduce the four wave mixing effect. The four wave mixing effect has been analyzed for different values of fiber length and dispersion parameter but the comparison of four wave mixing on the basis of number of input channels/users at different channel spacing is rarely done. In this chapter, the effect of four wave mixing at the output is considered for different number of channels like 2, 4, 6, 8, 12 at various values of channel spacing like 6.25 GHz, 12.5 GHz, 25 GHz, 40 GHz, 50 GHz.

This chapter is divided into different sections. In the first section, the introduction of four wave mixing effect is presented. In the second section, the schematic model is proposed. The third section describes the simulation setup for an optical communication system implementing these requirements. In the fourth section, the comparison of four wave mixing on the basis of different number of input channels/users at various spacing values is done in terms of eye diagrams, BER, Q-factor and eye opening. The fifth section gives the conclusion of this chapter.

## 5.2 SCHEMATIC MODEL

The schematic model for an optical communication system implementing the four wave mixing effect for different number of channels at different channel spacings is presented in figure 5.1. Number of input channels vary as 2, 4, 6, 8 and 12. The input channel consists of a continuous wave laser, modulator, data source and a modulator driver. The channel spacing is set at different values as specified earlier. The signals transmitted from each of these transmitters are combined together using a multiplexer. Then the multiplexed signal is sent over the fiber which adds the non linear effects like four wave mixing in the transmitted signal. Then the signal is passed through the receiver via fiber grating. The receiver contains the PIN photodiode and a low pass filter used to reconstruct the input signal.



**Figure 5.1** Schematic model

### 5.3 SIMULATION SETUP

The simulation setup for showing the effect of changing the number of input channels at various channel spacing on four wave mixing is shown in figure 5.2. The continuous wave laser (L1-L12) in the transmitter section is used to create the carrier signal. In this setup, twelve users are taken in account whose wavelengths have a specific difference i.e. spacing between them. The wavelength of first user is kept at 192.975 nm. The wavelengths of next users is set as per the spacing requirement i.e. at frequency difference of 6.25 GHz, 12.5 GHz, 25 GHz, 40 GHz and 50 GHz. The number of input channels/users vary as 2, 4, 6, 8 and 12 with each value of channel spacing. The data source (ds1-ds12) is used to generate the random input data bit sequence at the bit rate of 10 Gbps. The light signal modulates the input data. The modulator (m1-m12) is driven by the modulator driver (d1-d12) which decides the input data format. The input data format used here is NRZ raised cosine. The modulated data from all the users is combined using a combiner (c1). The post amplifier (a1) amplifies the signal before allowing it to enter into the fiber to avoid losses. Then this signal is sent over the fiber of length 100 Km. All the attenuation, dispersion and non linear effects are activated. Then the signal is passed through the fiber bragg grating (g1) which is used to compensate the dispersion at each step. The in-line amplifier (a2) amplifies the signal in the transmission medium itself. Then the signal is again passed through a fiber (f2) and fiber bragg grating (g2). Then pre-amplifier (a3) is used to amplify the signal before allowing it to enter into the receiver section. After amplification, the signal reaches the receiver. At the receiver, the signal is demultiplexed by using a splitter (s1) which splits this signal into the same number of signals as were transmitted. The photodiode (p1) is used for optical to electrical conversion. Then the signal is passed through the low pass filter (Lf1) and the final output signal is received. An optical scope (probe1) is attached at the output of combiner to examine the input signal. Another optical scope (probe2) is placed at the output of splitter to examine the four wave mixing effect in frequency spectrum. An electrical scope (scope2) is kept at the receiver output to examine the eye diagram, BER, Q-factor.

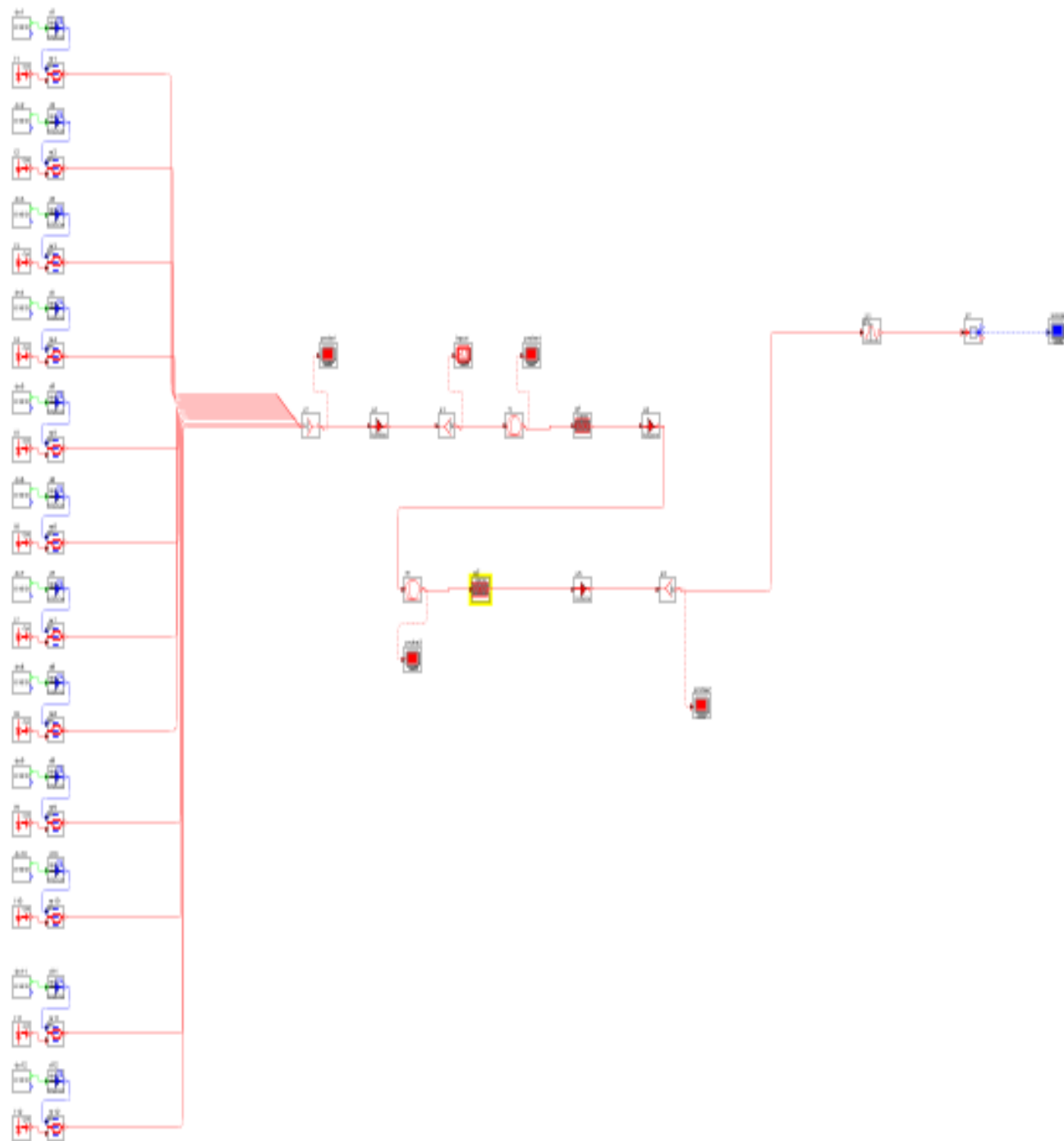


Figure 5.2 Simulation setup

## 5.4 RESULTS AND DISCUSSION

Using simulation setup, the value of BER, Q-factor, eye diagrams, eye opening is measured. Optical scope measures the input frequency spectrum. BER, eye diagrams and Q-factor is measured at the receiver output by using an electrical scope.

Figure 3.3 shows the input optical spectrum for the channel spacing of 20 GHz when 8 input channels are taken. On changing the spacing between the different users, the peaks get shifted to the frequencies as specified in the laser. The analysis is done on the eye diagrams in this case.

Figure 5.3 describes the eye diagram of the receiver output when different number of input channels are taken with channel spacing of 6.25 GHz. Figure 5.3 (a) shows the eye diagram for 6.25 GHz channel spacing when 2 input channels are taken. Figure 5.3 (b) shows the eye diagram when 4 input channels are taken in account. Figure 5.3 (c) shows the eye diagram when 6 input channels are taken in account. Figure 5.3 (d) shows the eye diagram when 8 input channels are taken in account. Figure 5.3 (e) shows the eye diagram when 12 input channels are taken in account.

Figure 5.3 Eye diagram for channel spacing of 6.25 GHz

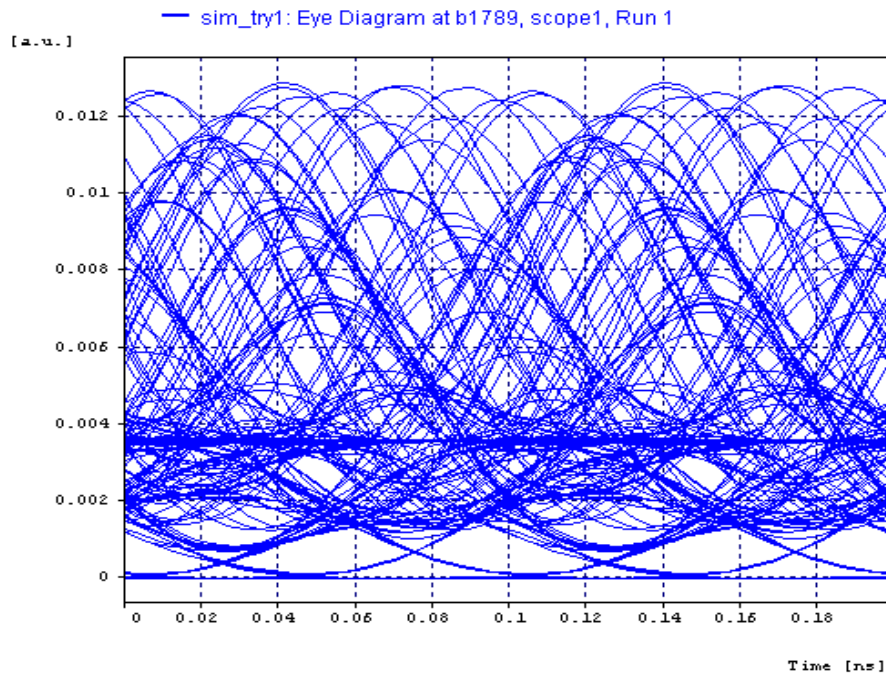
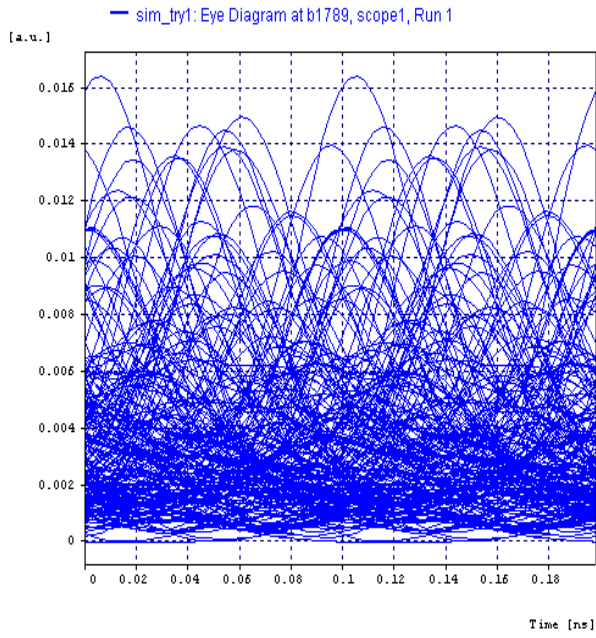
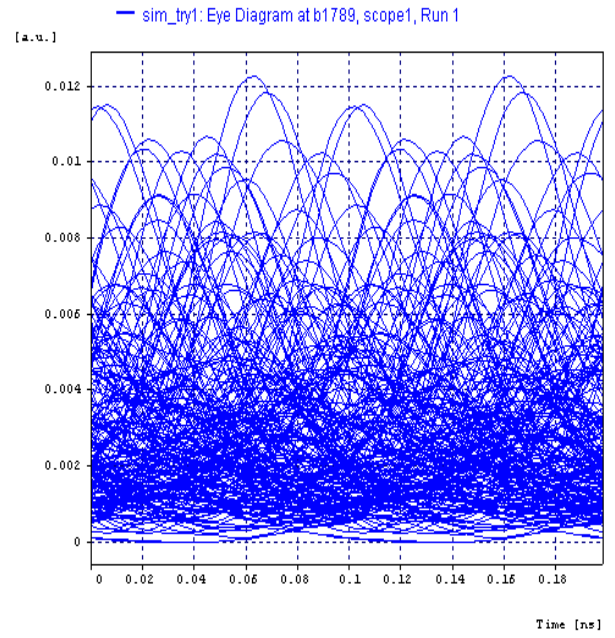


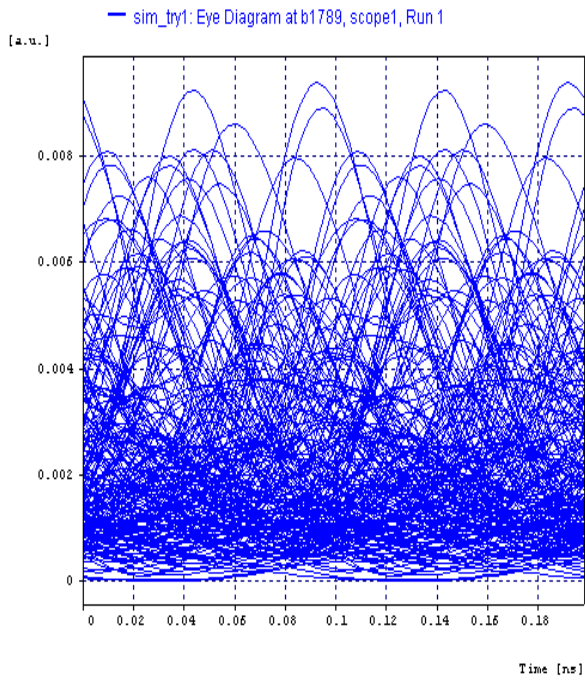
Figure 5.3 (a)



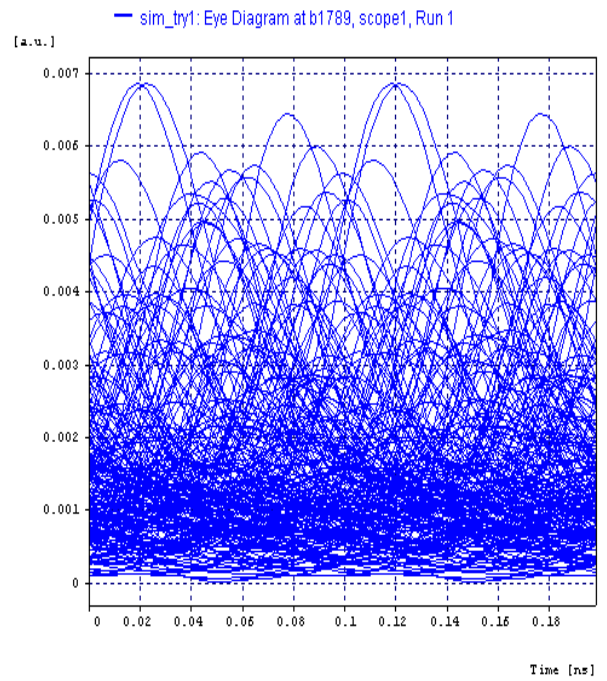
**Figure 5.3 (b)**



**Figure 5.3 (c)**



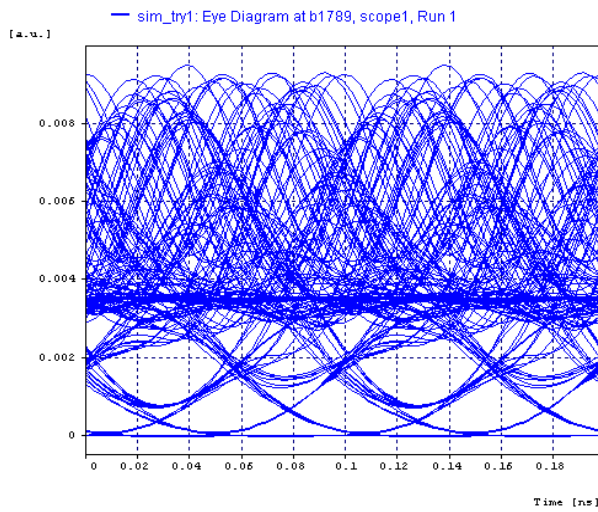
**Figure 5.3 (d)**



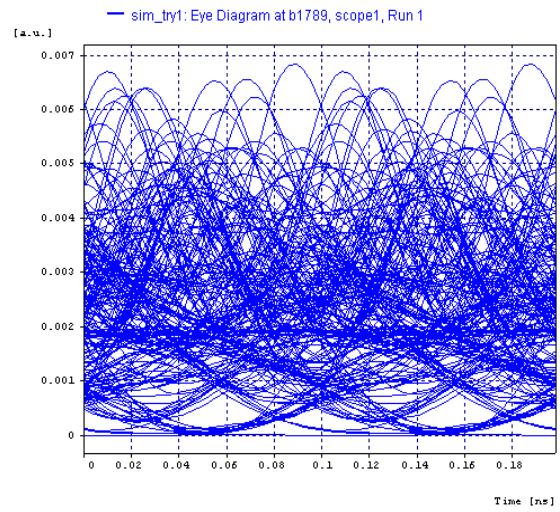
**Figure 5.3 (e)**

As the channel spacing is very small so the interference between the input frequencies is large and thus, the eye diagrams are not so clear. Moreover, as the number of input channels increases, the interference increases.

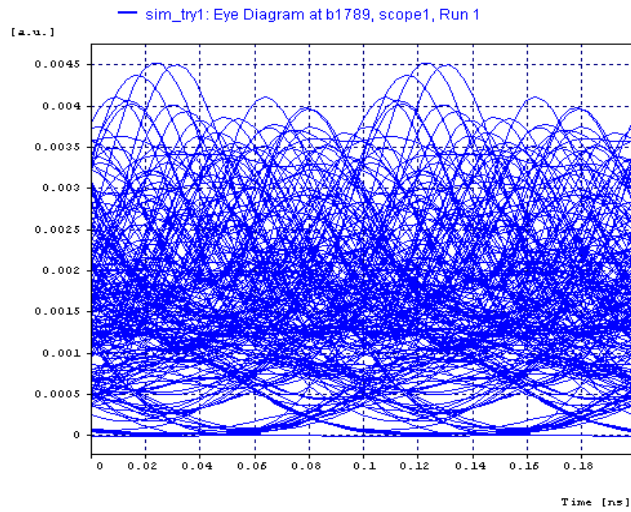
Figure 5.4 shows the eye diagram for different number of input channels with channel spacing of 12.5 GHz. Figure 5.4 (a) describes the eye diagram when 2 channels are taken. Figure 5.4 (b) describes the eye diagram when 4 channels are taken. Figure 5.4 (c) describes the eye diagram when 6 channels are taken. Figure 5.4 (d) describes the eye diagram when 8 channels are taken. Figure 5.4 (e) describes the eye diagram when 12 channels are taken.



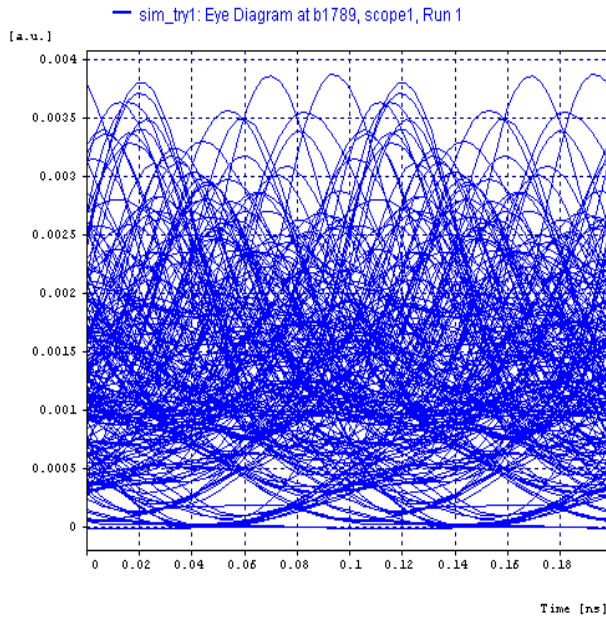
**Figure 5.4 (a)**



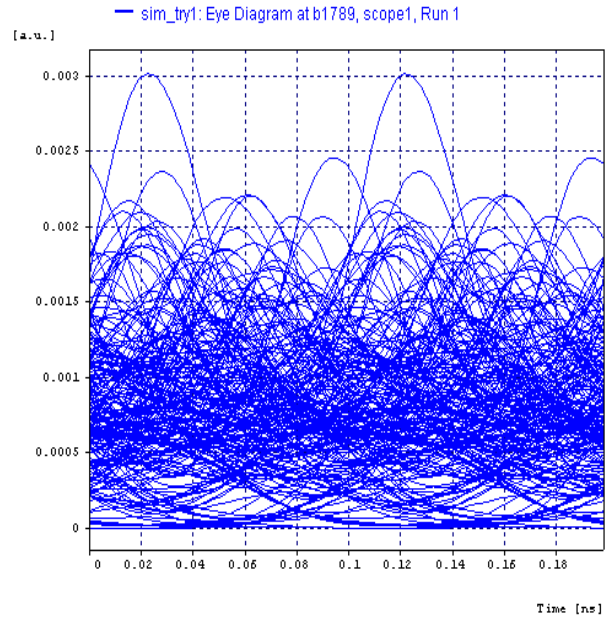
**Figure 5.4 (b)**



**Figure 5.4 (c)**

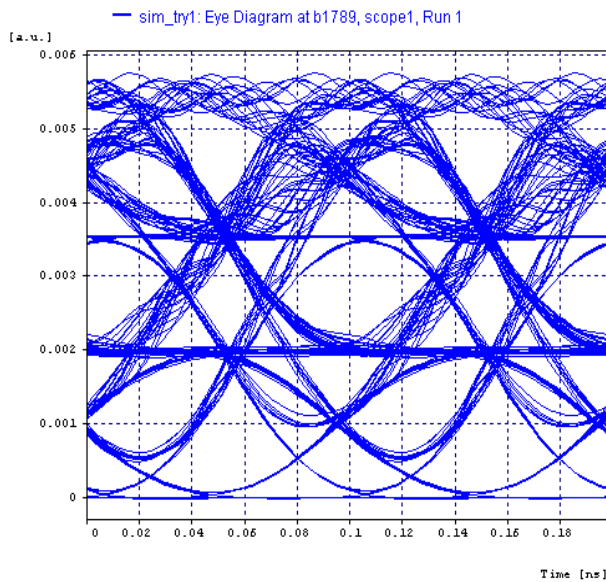


**Figure 5.4 (d)**

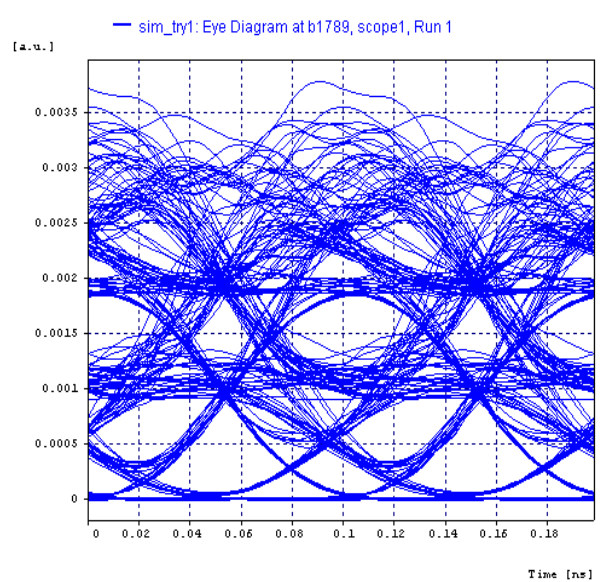


**Figure 5.4 (e)**

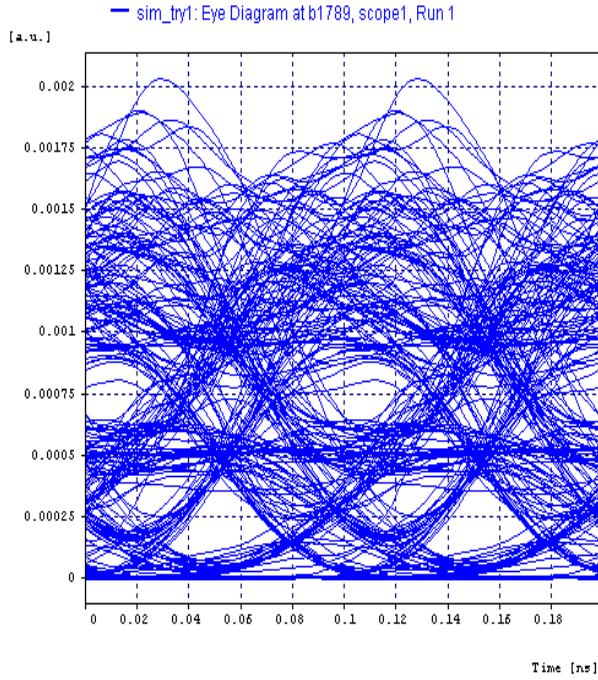
Figure 5.5 shows the eye diagram for different number of input channels with channel spacing of 25 GHz. Figure 5.5 (a) describes the eye diagram when 2 channels are taken. Figure 5.5 (b) describes the eye diagram when 4 channels are taken. Figure 5.5 (c) describes the eye diagram when 8 channels are taken. Figure 5.5 (d) describes the eye diagram when 10 channels are taken. Figure 5.5 (e) describes the eye diagram when 12 channels are taken.



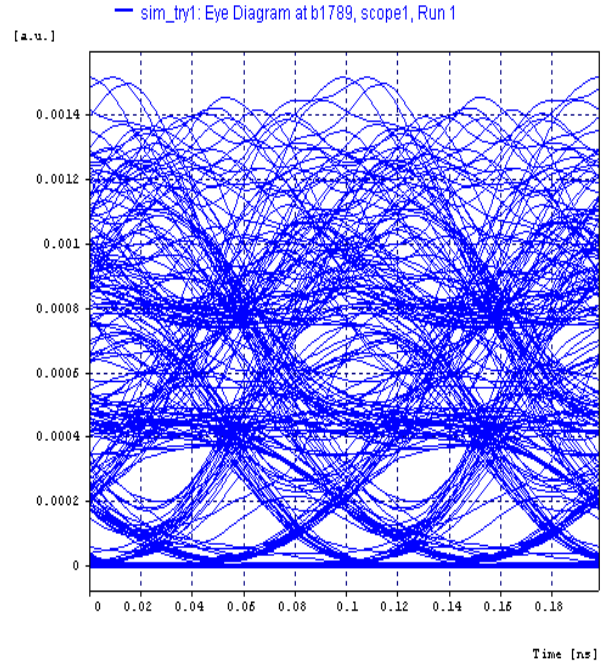
**Figure 5.5 (a)**



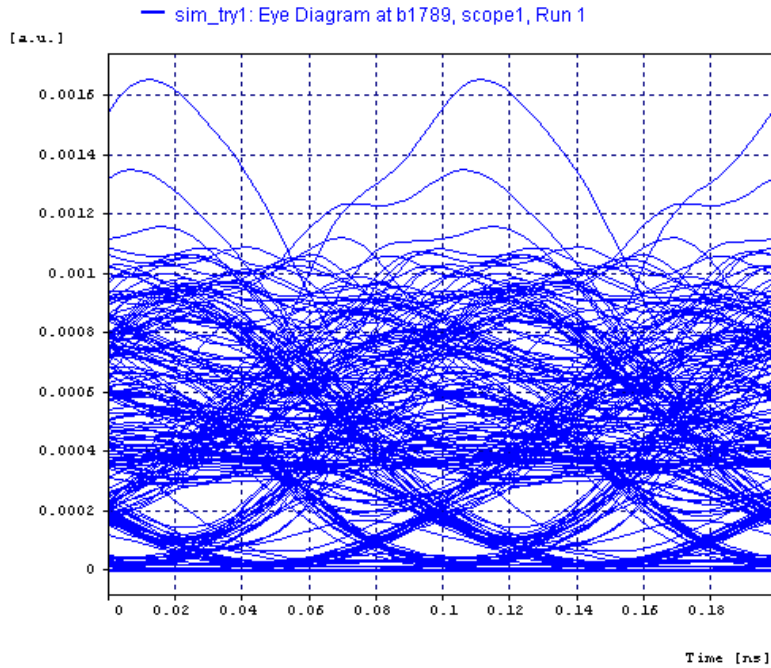
**Figure 5.5 (b)**



**Figure 5.5 (c)**



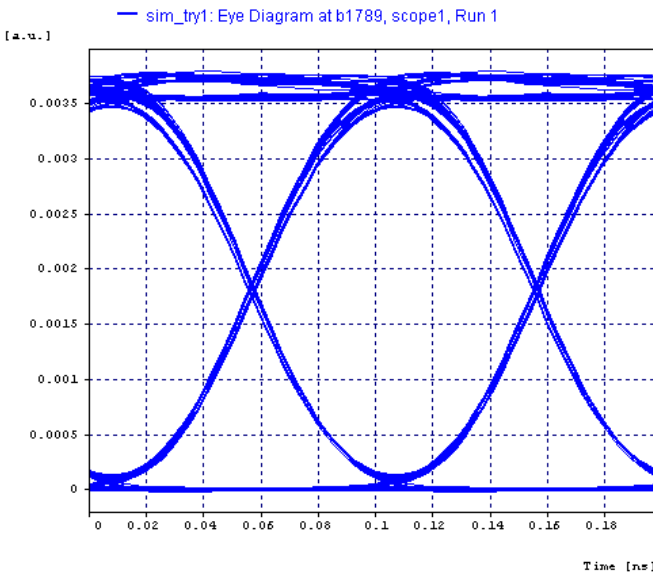
**Figure 5.5 (d)**



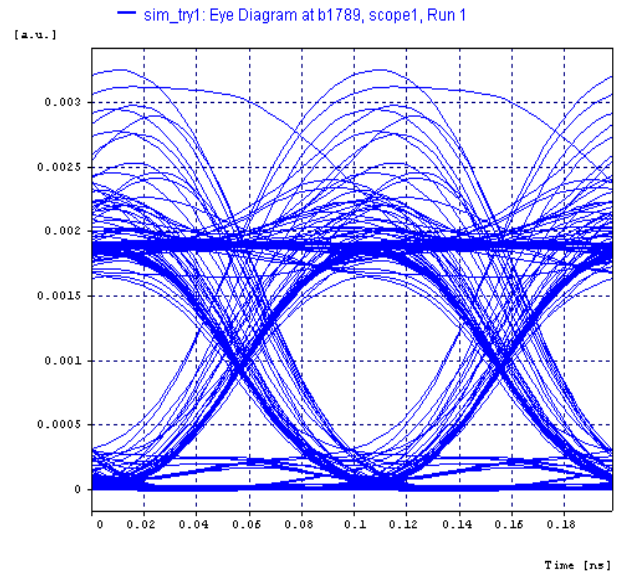
**Figure 5.5 (e)**

The above eye diagrams show that as the number of input channels increases, the clarity of eye diagram diminishes.

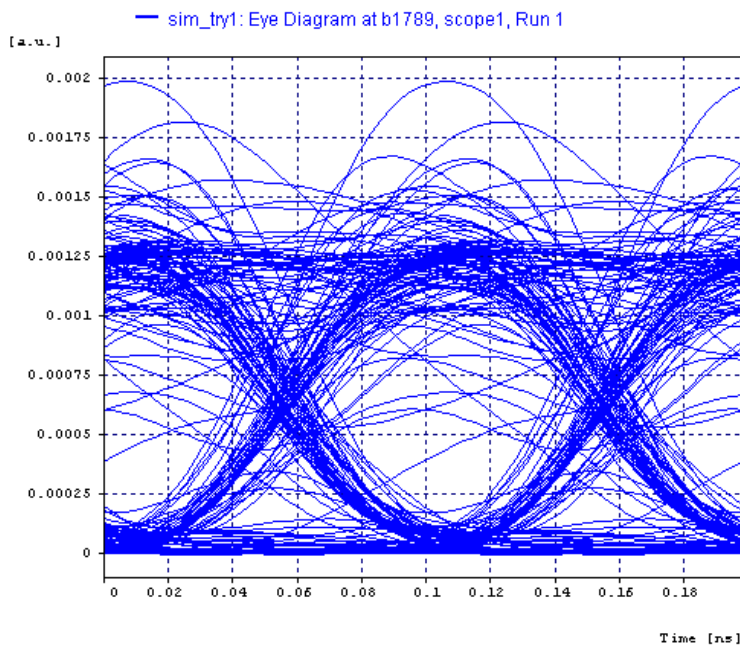
Figure 5.6 shows the eye diagram for different number of input channels with channel spacing of 40 GHz. Figure 5.6 (a) describes the eye diagram when 2 channels are taken. Figure 5.6 (b) describes the eye diagram when 4 channels are taken. Figure 5.6 (c) describes the eye diagram when 6 channels are taken. Figure 5.6 (d) describes the eye diagram when 8 channels are taken. Figure 5.6 (e) describes the eye diagram when 12 channels are taken.



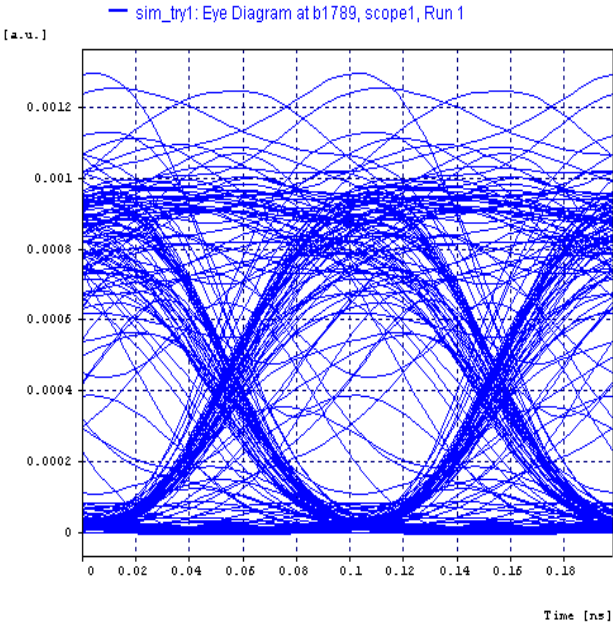
**Figure 5.6 (a)**



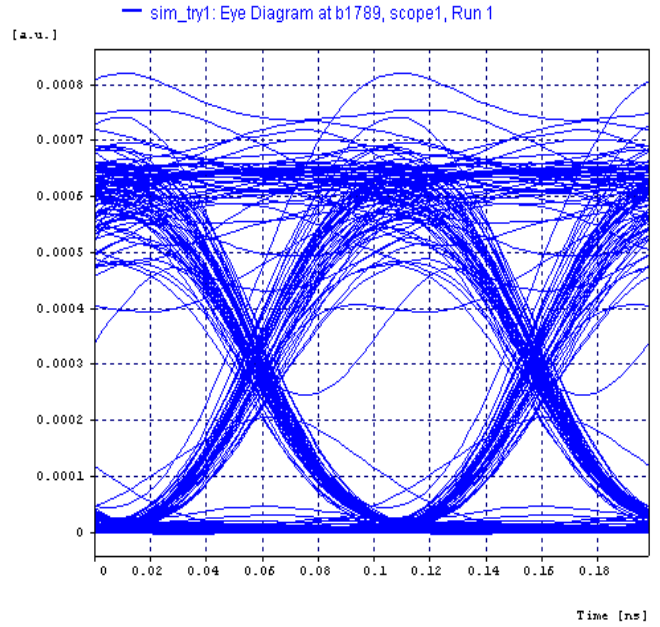
**Figure 5.6 (b)**



**Figure 5.6 (c)**

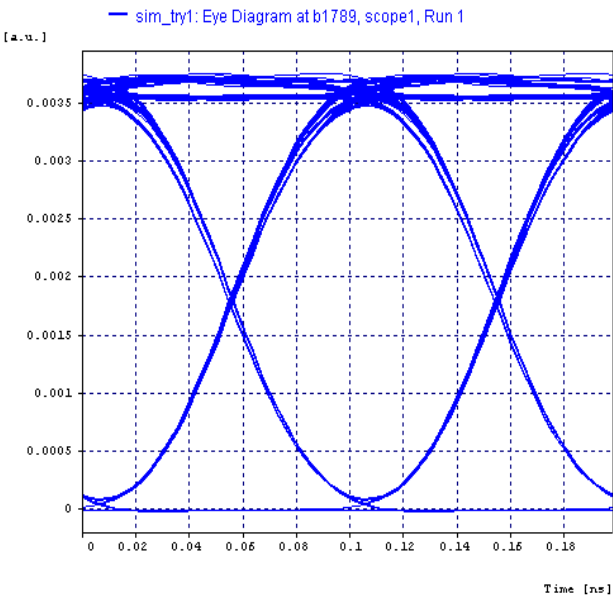


**Figure 5.6 (d)**

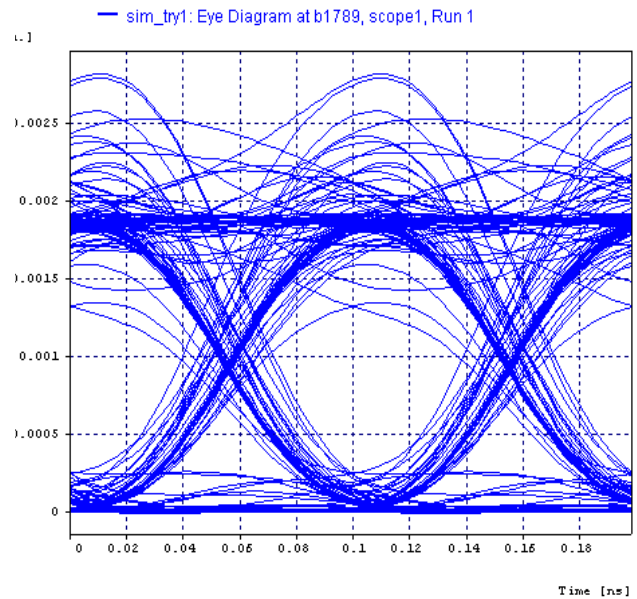


**Figure 5.6 (e)**

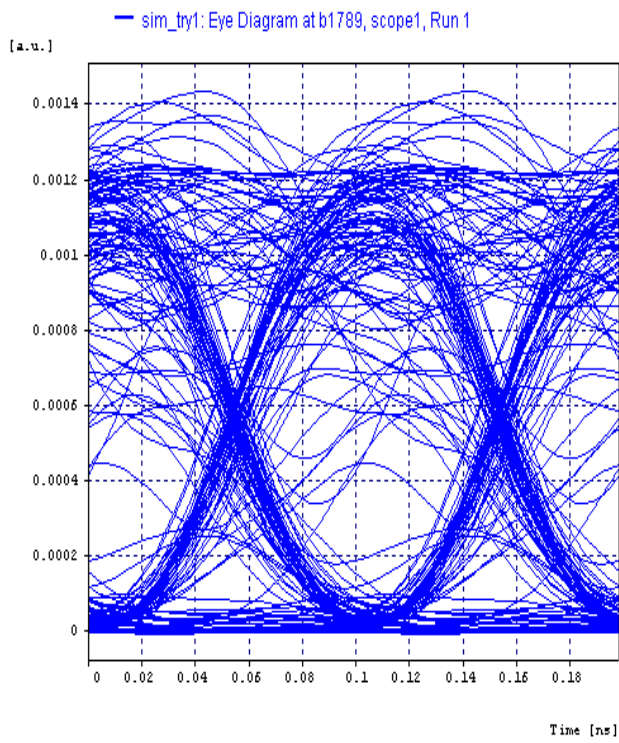
Figure 5.7 shows the eye diagram for different number of input channels with channel spacing of 50 GHz. Figure 5.7 (a) describes the eye diagram when 2 channels are taken. Figure 5.7 (b) describes the eye diagram when 4 channels are taken. Figure 5.7 (c) describes the eye diagram when 6 channels are taken. Figure 5.7 (d) describes the eye diagram when 8 channels are taken. Figure 5.7 (e) describes the eye diagram when 12 channels are taken.



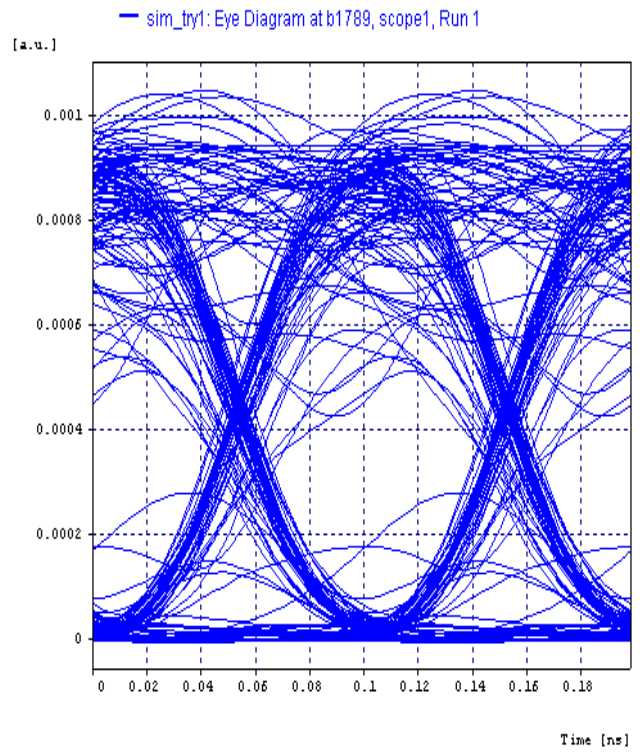
**Figure 5.7 (a)**



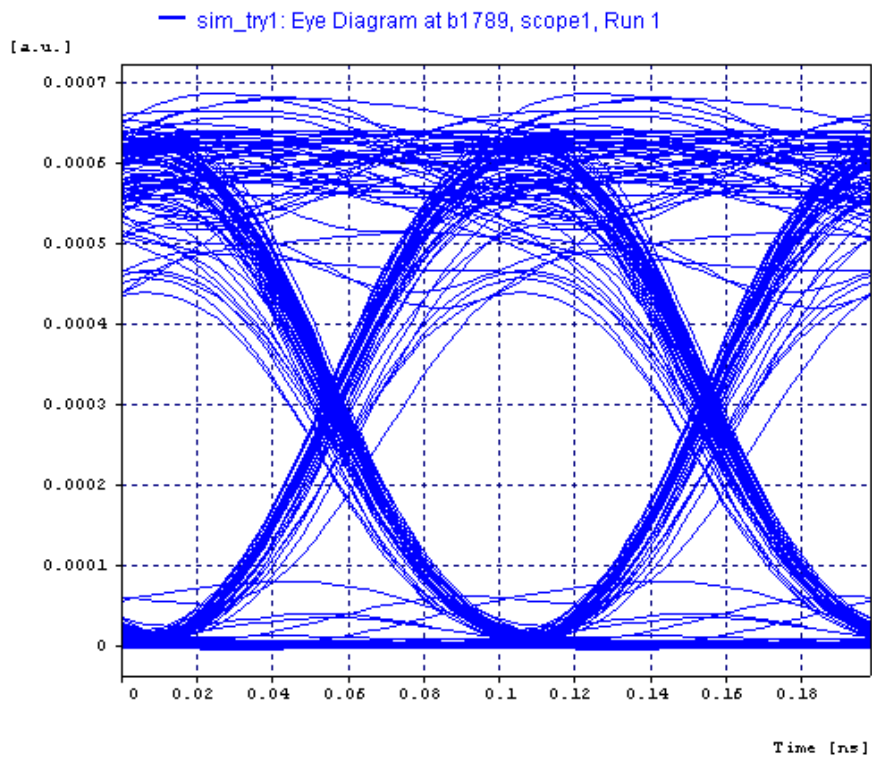
**Figure 5.7 (b)**



**Figure 5.7 (c)**



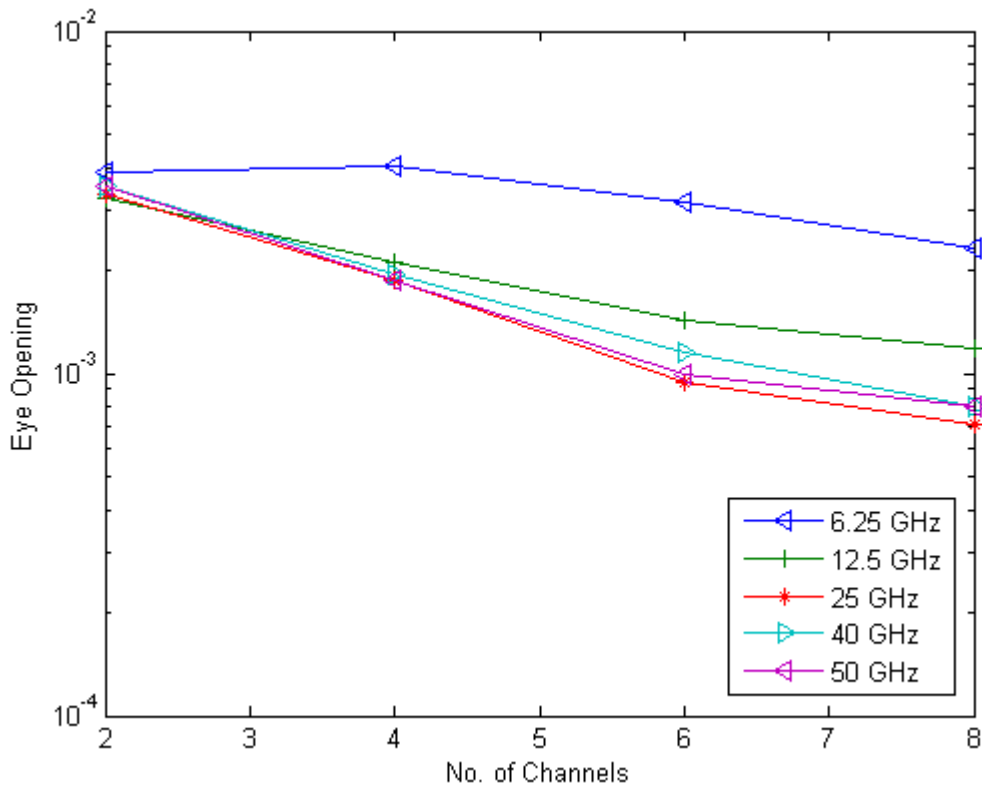
**Figure 5.7 (d)**



**Figure 5.7 (e)**

The above eye diagrams reveal that on increasing the channel spacing, the interference between input frequencies decreases and hence, the four wave mixing effect also decreases. Moreover, on increasing the number of input channels/users, the interference again increases and thus, the four wave mixing effect also increases.

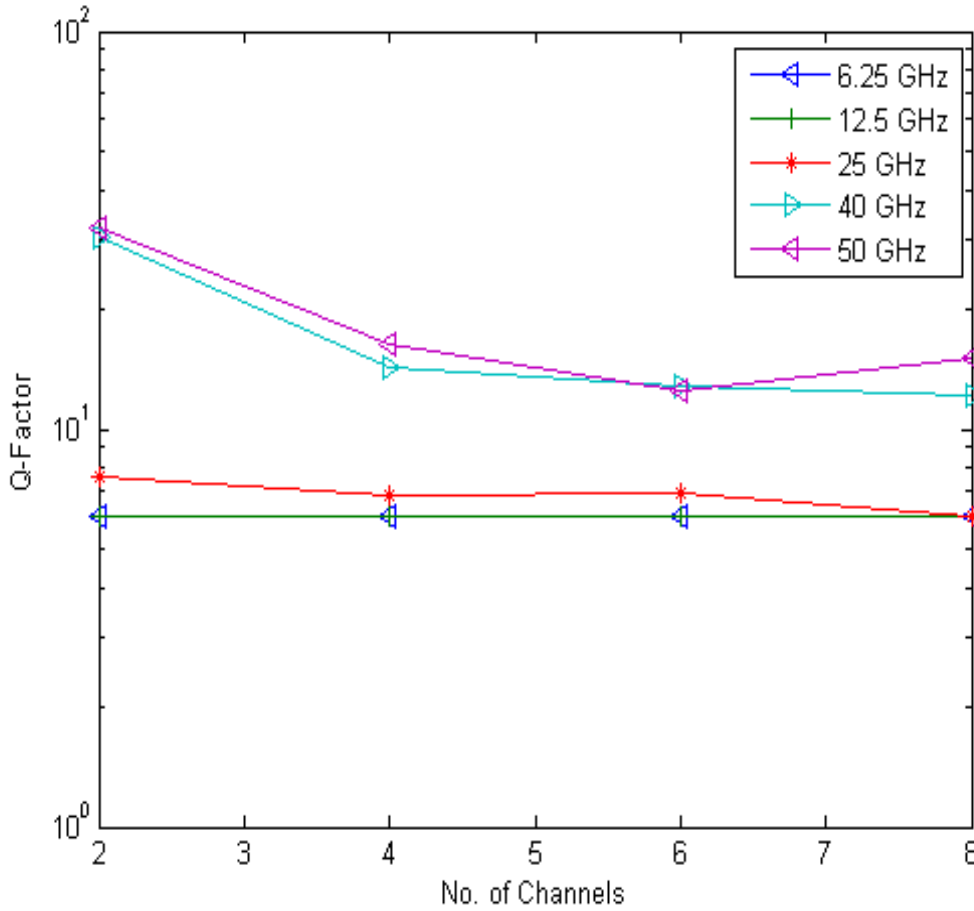
Figure 5.8 shows the variation of eye opening with respect to the number of channels at various values of channel spacing.



**Figure 5.8** Variation of Eye opening with respect to number of channels

The above graph shows that with the increasing channel spacing, the eye opening decreases. It can also be seen that the eye opening decreases as the number of channels increases.

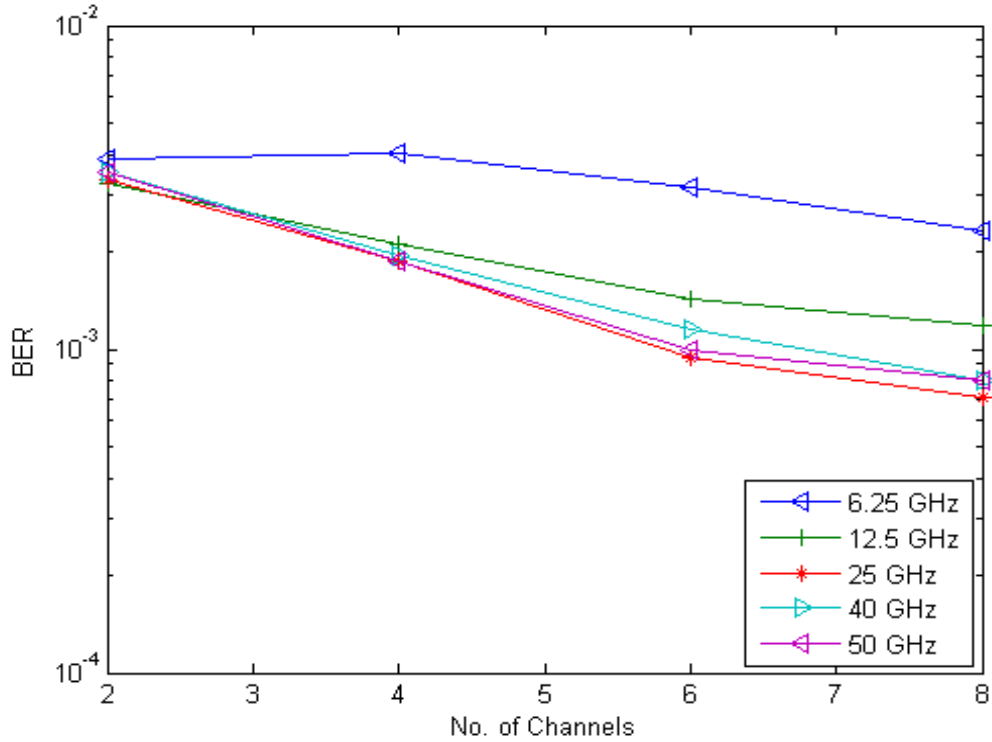
Figure 5.9 represents the variation of Q-factor with respect to the number of channels at various values of channel spacing.



**Figure 5.9** Variation of Q-factor with respect to number of channels

The graph shows that on increasing the number of channels, the Q-factor decreases. At lower values of channel spacing, the Q-factor is very small but on increasing the channel spacing, the Q-factor increases.

Figure 5.10 shows the variation of BER with respect to number of channels at various values of channel spacing.



**Figure 5.10** Variation of BER with respect to number of channels

The graph reveals that as the number of channels increases, the BER also increases. But with the increasing channel spacing, the BER decreases.

## 5.5 CONCLUSION

In this chapter, the design, implementation and performance analysis of four wave mixing in optical communication system for different number of input channels at various values of channel spacing is presented. It has been observed that on increasing the number of input channels/users, the interference again increases and thus, the four wave mixing effect also increases. The eye opening decreases as the number of channels increases. Increasing the number

of channels causes the Q-factor to decrease. Moreover, as the number of channels increases, the BER also increases. Thus, it can be concluded that the four wave mixing is least when less number of channels are used but in today's technology, it is important for the circuit to handle wavelength division multiplexing i.e. different users can use the bandwidth at the same time without any interference so this drawback of four wave mixing should be minimized.

# CHAPTER 6

## CONCLUSION AND FUTURE SCOPE

---

This chapter provides a summary of the findings of the study which has been done so far. Also, in this chapter, the scope for further research in fiber non linearities is given.

### 6.1 CONCLUSION

The first objective of thesis is to investigate the four wave mixing effect on bit error rate, Q-factor, output spectrums and eye diagrams at different channel spacing. The design, implementation and performance analysis of four wave mixing in optical communication system for different values of spacing between input channels has been done. The comparison of four wave mixing effect at various values of channel spacing revealed that 75 GHz spacing has the edge over 6.25 GHz spacing in optical communication system. It is found that spacing of 75 GHz has the lowest BER and better system performance. Hence, the higher spacing values between the input channels is recommended for long distance transmission without four wave mixing. It can be seen from the graphs of BER, Q-factor and eye opening that higher channel spacing gives the best performance as compared to lower channel spacing. Hence, it is concluded that higher channel spacing is best suitable to be employed in the optical communication systems minimizing the four wave mixing effect.

The second objective of thesis is to design and analyze performance the four wave mixing effect on changing various components in the system. Components involve different data sources like pn-sequence generator with different bit rate; modulator drivers like NRZ and RZ raised cosine, NRZ and RZ rectangular, RZ supergaussian, RZ soliton; modulators like linear amplitude, linear electroabsorption and optical phase modulator; laser with different power values. The extent of four wave mixing is considered for each and every component separately. The comparison of four wave mixing with different components revealed that changing the bit rate of data source doesnot effect the four wave mixing at the output. Changing the modulator drivers least effects the four wave mixing. NRZ raised cosine modulator driver gives the least four wave mixing. On changing the modulator, the four wave mixing is largely effected. The linear amplitude

modulator gives the best system performance and the optical phase modulator gives the worst performance among all the modulators. Hence, it is concluded that linear amplitude modulator is best suitable to be employed in the optical communication system minimizing the four wave mixing effect. Also, the eye opening and the Q-factor increases on increasing the laser power. Moreover, the bit error rate is minimum when the power level of laser is maximum.

The third objective of thesis is to investigate four wave mixing effect with different number of channels at various channel spacings. All the input channels are spaced evenly at various values like 6.25 GHz, 12.5 GHz, 25 GHz, 40 GHz, 50 GHz with the different number of channels at the input i.e. with 2, 4, 6, 8, 12 input channels. The effect of four wave mixing has been analyzed for each channel spacing with these number of channels in terms of eye diagrams, BER, eye opening and Q-factor. It has been observed that on increasing the number of input channels/users, the interference again increases and thus, the four wave mixing effect also increases. The eye opening decreases as the number of channels increases. Increasing the number of channels causes the Q-factor to decrease. Moreover, as the number of channels increases, the BER also increases. Thus, it can be concluded that the four wave mixing is least when less number of channels are used but in today's technology, it is important for the circuit to handle wavelength division multiplexing i.e. different users can use the bandwidth at the same time without any interference so this drawback of four wave mixing should be minimized.

## **6.2 FUTURE SCOPE**

In this thesis, the work is limited to four wave mixing effect. The variation of bit error rate, Q-factor, eye opening and output spectrums with four wave mixing on changing various parameters like channel spacing, number of channels, various components like modulators, drivers etc have been considered. The effect of changing these parameters for self phase modulation, cross phase modulation i.e. other Kerr effects can be studied.

Four wave mixing can be used for various applications like wavelength conversion. So, various applications of four wave mixing can be further studied.

Also, different other methods of reducing the four wave mixing effect can be explored.

## REFERENCES

---

- [1] Tomoaki Ohtsuki and Iwao Sasase, "Optical Synchronous CDMA, Encyclopedia of Telecommunications" Editor: John Proakis, Wiley, 2002.
- [2] A.J. Mendez, R.M. Gagliardi, V.J. Hernandez, C.V. Bennett, and W. J. Lennon, "Design and Performance Analysis of Wavelength/Time (W/T) Matrix Codes For Optical CDMA," IEEE Journal of Lightwave Technology, vol. 21, pp. 2524-2533, November 2003.
- [3] Don Warren and Justin Moore, "Multiplexing in Fiber Optic Connections", Summer Ventures in Science and Mathematics, 2001.
- [4] Diptish Dey, "Theory towards an all optical WDM slotted ring MAN with support for optical multicasting", Ph.D. Thesis, University of Twente, June 2003.
- [5] T. Tsuritani, I. Morita, A. Agata, and N. Edagawa, "Study on optimum optical prefiltering condition for highly spectral-efficient ultralong haul transmission using 40 Gbit/s CS-RZ signal and all-Raman repeaters," presented at the OFC2003, paper FE4, Atlanta, GA, 2003.
- [6] T. Otani, M. Hayashi, M. Daikoku, K. Ogaki, Y. Nagao, K. Nishijima, and M. Suzuki, "Field trial of 63 channels 40 Gbit/s dispersion-managed soliton WDM signal transmission over 320 km NA-DSFs," presented at the OFC, paper FC9, Anaheim, CA, 2002.
- [7] Anes Hodžić, Student Member, Marcus Winter, Beate Konrad, Sebastian Randel, and Klaus Petermann, "Optimized Filtering for 40-Gb/s/Ch-Based DWDM Transmission systems Over Standard Single-Mode Fiber" IEEE Photonics Technology Letters, Vol. 15, No. 7, pp. 1002-1004, July 2003.

- [8] Yutaka Miyamoto, Tomoyoshi Kataoka, Kazushige Yonenaga, Masahito Tomizawa, Akira Hirano, Shoichiro Kuwahara, and Yasuhiko Tada “WDM Field Trials of 43-Gb/s/Channel Transport System for Optical Transport Network” *IEEE Journal Of Lightwave Technology*, Vol. 20, No. 12, pp. 2115-2128, December 2002.
- [9] Takehiro Tsuritani, Akira Agata, Itsuro Morita, Noboru Edagawa, and Shigeyuki Akiba, “Ultra-Long-Haul 40-Gbit/s-Based DWDM Transmission Using Optically Prefiltered CS-RZ Signals” *IEEE Journal Of Selected Topics In Quantum Electronics*, Vol. 10, No. 2, pp. 403-411, April 2004.
- [10] Jin-Xing Cai, Carl R. Davidson, Morten Nissov, Haifeng Li, William T. Anderson, “Transmission of 40-Gb/s WDM Signals Over Transoceanic Distance Using Conventional NZ-DSF With Receiver Dispersion Slope Compensation” *IEEE Journal Of Lightwave Technology*, Vol. 24, No. 1, pp. 191-200, January 2006.
- [11] Masahiro Daikoku, Tetsuya Miyazaki, Itsuro Morita, Hideaki Tanaka, Fumito Kubota, and Masatoshi Suzuki “8 X 160-Gb/s WDM Field Transmission Experiment With Single-Polarization RZ-DPSK Signals and PMD Compensator” *IEEE Photonics Technology Letters*, Vol. 18, No. 2, pp. 391-393, January 15, 2006.
- [12] Lara D. Garrett, Michael H. Eiselt, Jay M. Wiesenfeld, Marvin R. Young, and Robert W. Tkach, “Bidirectional ULH Transmission of 160-Gb/s Full-Duplex Capacity Over 5000 km in a Fully Bidirectional Recirculating Loop” *IEEE Journal Of Lightwave Technology*, Vol. 16, No. 7, pp. 1757-1759, July 2003.
- [13] L. H. Spiekman, J. M. Wiesenfeld, A. H. Gnauck, L. D. Garrett, G. N. van den Hoven, T. van Dongen, M. J. H. Sander-Jochem, and J. J. M. Binsma “Transmission of 8 DWDM Channels at 20 Gb/s over 160 km of Standard Fiber Using a Cascade of Semiconductor Optical Amplifiers” *IEEE Journal Of Lightwave Technology*, Vol. 12, No. 6, pp. 717-719, June 2000.
- [14] G. Charlet, E. Corbel, J. Lazaro, A. Klekamp, W. Idler, R. Dischler, S. Bigo, “Comparison of system performance at 50, 62.5 and 100 GHz channel spacing over

- transoceanic distances at 40 Gbit/s channel rate using RZ-DPSK” *Electronics Letters* 3<sup>rd</sup>, Vol. 41, No. 3, February 2005.
- [15] E. Pincemin, D. Grot, C. Borsier, J. D. Ania-Castañón, and S. K. Turitsyn “Impact of the Fiber Type and Dispersion Management on the Performance of an NRZ 16 x 40 Gb/s DWDM Transmission System” *IEEE Photonics Technology Letters*, Vol. 16, No. 10, pp. 2362-2364, October 2004.
- [16] G. P. Agrawal, "Nonlinear Fiber Optics, Second Edition", Academic Press, San Diego, USA, Chap. 10, 1995.
- [17] Yamamoto, *Optical Fiber Communications Technology*, Nikkan Kogyo Shimbun, Chap. 11, 1995.
- [18] I. E. Fonseca<sup>1</sup>, M. R. N. Ribeiro, and H. Waldman, “Differentiated optical QoS under a Low Complexity FWM-aware Wavelength Assignment Algorithm,” *Conference on Optical Network Design and Modeling*, pp. 431-438, February 2005.
- [19] P. L. Li, D. X. Huang, X. L. Zhang, J. Chen, and L. R. Huang,” *Theoretical Analysis of Tunable Wavelength Conversion Based on FWM in a Semiconductor Fiber Ring Laser*,” *IEEE Journal of quantum electronics*, Vol. 41, No. 3, pp. 581-588, March 2005.
- [20] S. Pachnicke, E. De Man, S. Spälter, and E. Voges, “Impact of the In-Line Dispersion-Compensation Map on Four-Wave Mixing (FWM) – Impaired Optical Networks,” *IEEE Photonics Technology Letters*, Vol. 17, No. 1, pp. 235-237, January 2005.
- [21] Ozan K. Tonguzc, Bohyeon Hwang, “A generalized suboptimum unequally spaced channel allocation technique—Part I: in IM/DD WDM systems”, *IEEE Transactions Communication*, Vol. 46, No. 8, pp. 1027–1037, 1998.
- [22] G. Charlet, E. Corbel, J. Lazaro, A. Klekamp, W. Idler, R. Dischler, S. Bigo, “Comparison of system performance at 50, 62.5 and 100 GHz channel spacing over

- transoceanic distances at 40 Gbit/s channel rate using RZ-DPSK” *Electronics Letters* 3<sup>rd</sup>, Vol. 41, No. 3, February 2005.
- [23] Osamu Aso, Masateru Tadakuma and Shu Namiki,” Four-Wave Mixing in Optical Fibers and Its Applications”, WP Team, Opto-technology Lab., R & D Div.
- [24] Edmund Kueh Boon Kiang, S. P. Majumder, “Analytical Evaluation of the Impact of Four Wave Mixing on the Bit Error Rate Performance of a WDM Soliton Transmission Link”, *Journal of Optical Communications*, Vol. 23, No. 4, pp. 122-126, 2002.
- [25] Shu Jia, Wenjie Wan, and Jason W. Fleischer, “Forward four-wave mixing with defocusing nonlinearity”, *Optics Letters*, Vol. 32, No. 12, pp. 1668-1670, June 15, 2007.
- [26] A. Yariv and D. M. Pepper, “Amplified reflection, phase conjugation and oscillation in degenerate four wave mixing”, *Optics Letters*, Vol. 1, No. 16, 1977.
- [27] R.W. Tkach, A.R. Chraplyvy, F. Forgiari, A.H. Gnauck, R.M. Derosier, “Four-photon mixing and high-speed WDM systems”, *Journal of Lightwave Technology*, pp. 8841–8849, 1995.
- [28] Shuxian Song, C.T. Allen, K.R. Demarest, Rongqing Hui, Intensity dependent phase matching effects on four wave mixing in optical fiber, *Journal of Lightwave Technology*, pp. 2285–2290, 1999.
- [29] G.P. Agarwal, *Fiber Optic Communication Systems*, Wiley, New York, 1997.
- [30] Bohyeon Hwang, Ozan K. Tonguz, A generalized suboptimum unequally spaced channel allocation technique—Part I: in IM/DD WDM systems, *IEEE Trans. Communication*, Vol. 46, No. 8, pp. 1027–1037, 1998.
- [31] David F. Geraghty, Robert B. Lee, Marc Verdiell, Mehrdad Ziari, Atul Mathur, and Kerry J. Vahala, “Wavelength Conversion for WDM Communication Systems Using

- Four-Wave Mixing in Semiconductor Optical Amplifiers”, IEEE Journal of selected topics in quantum electronics, Vol. 3, No. 5, pp. 1146-1155, OCTOBER 1997.
- [32] C. A. Brackett, “Is there an emerging consensus on WDM networking,” Journal of Lightwave Technology, Vol. 14, pp. 936–941, 1996.
- [33] S. B. Alexander, “A precompetitive consortium on wide-band all-optical networks,” J. Lightwave Technology, Vol. 11, pp. 714–732, 1993.
- [34] C. A. Brackett, “A scalable multiwavelength multihop optical network: A proposal for research on all-optical networks,” Journal of Lightwave Technology, Vol. 11, pp. 736–752, 1996.
- [35] J. M. Wiesenfeld, “Gain dynamics and associated nonlinearities in semiconductor optical amplifiers in current trends in optical amplifiers and their applications”, T. P. Lee, Ed. New York: World Scientific, 1996.
- [36] J. M. Wiesenfeld, B. Glance, J. S. Perino, and A. H. Gnauck, “Wavelength Conversion at 10 Gb/s using a semiconductor optical amplifier,” IEEE Photonic Technology Letters, Vol. 5, pp. 1300–1303, 1993.
- [37] T. Durhuus, B. Mikkelsen, C. Joergensen, S. L. Danielsen, and K. E. Stubkjaer, “All-optical wavelength conversion by semiconductor optical amplifiers,” Journal of Lightwave Technology, Vol. 14, pp. 942–954, 1996.
- [38] S. L. Danielsen, C. Jorgensen, B. Mikkelsen, P. B. Hansen, H. N. Poulsen, and K. El Stubkjaer, “Wavelength converters: Network application and systems experiments”, presented at Conference: Lasers and Electro-Optics, Baltimore, MD, paper CMF4, pp. 18–23, May 1997.
- [39] J. M. Wiesenfeld, “Wavelength conversion: Physics and devices,” presented at the Conference: Lasers and Electro-Optics, Baltimore, MD, paper CMF1, pp. 18-23, May 1995.

- [40] S. J. B. Yoo, "Wavelength conversion technologies for WDM network applications," *Journal of Lightwave Technology*, Vol. 14, pp. 955–966, 1996.
- [41] J. Zhou, N. Park, J. W. Dawson, K. J. Vahala, M. A. Newkirk, and B. I. Miller, "Terahertz four-wave mixing spectroscopy for study of ultrafast dynamics in a semiconductor optical amplifier," *Applied Physics Letters*, Vol. 63, pp. 1179–1181, 1993.
- [42] Yasin M. Karfaa, Student Member, IEEE, M. Ismail, Member, IEEE, Abbou F. M, "Effects of Four-wave Mixing Crosstalk in WDM Networks on the Transmitted Optical Frequencies and Wavelengths of Channels for Various Fiber Types", Asia pacific conference on applied electromagnetic proceedings, December, 2007.
- [43] C. T. Politi, D. Klonidis, and M. J. O'Mahony, "Dynamic Behavior of Wavelength Converters based on FWM in SOAs," *IEEE journal of quantum electronics*, Vol. 42, No. 2, pp. 108-125, February 2006.
- [44] M.N. Petersen, K. Schulze and F. Ramos,"Dispersion Monitoring in all-optical Networks Using Wavelength Conversion Based on FWM," *Electronics Letters*, Vol. 43, No. 10, pp. 582-583, May 10, 2007.
- [45] S. W. Bang and D. G. Daut, "Analysis of CPM and FWM Phenomena for Various Signaling Formats in 16 Channel DWDM," *International Conference in Central Asia on Internet*, pp. 26-29, September 2005.
- [46] Y. Geng; P. A. Andersen, T. Tokle, C. Peucheret, P. Jeppesen, "Wavelength Conversion of a 6×40 Gbps DPSK WDM Signal using FWM in a Highly Nonlinear Photonic Crystal Fiber," *31st European Conference on Optical Communication*, Vol. 2, pp. 205-206 and 25-29, Sept. 2005.
- [47] A. Yariv and D. M. Pepper, "Amplified reflection, phase conjugation and oscillation in degenerate four wave mixing", *Optics Letters*, Vol. 1, No. 16, 1977.

- [48] P.O. Hedekvist, M. Karlsson, P.A. Andrekson, Fiber four wave mixing demultiplexing with inherent parametric amplification, *Journal of Lightwave Technology*, Vol. 15, No. 11, pp. 2501–2518, 1997.
- [49] Bohyeon Hwang, Ozan K. Tonguz, A generalized suboptimum unequally spaced channel allocation technique—Part I: in IM/DD WDM systems, *IEEE Trans. Communication*, Vol. 46, No. 8, pp. 1027–1037, 1998.
- [50] M. Witte, F. Fujita, I. Mito, K. Minemura, Reducing the optical power penalty for electronically dispersion compensated LED pulse transmission by using multi-bit shift decision feedback, *Electronic Letters*, Vol. 36, No. 5, 2000.