

ANALYSIS OF AGC USING CONVENTIONAL AND FUZZY LOGIC CONTROLLER

*Thesis submitted in partial fulfillment of the requirements for the award of
degree of*

**Master of Engineering
in
Power Systems & Electric Drives**



Thapar University, Patiala

By:
**Navreet Kaur
(80641014)**

Under the supervision of:
Ms Suman Bhullar

JUNE 2008

**ELECTRICAL & INSTRUMENTATION ENGINEERING
DEPARTMENT
THAPAR UNIVERSITY
PATIALA – 147004**

Certificate

I hereby certify that the work which is being presented in the thesis entitled, **“Analysis of AGC using conventional and Fuzzy Logic Controller”**, in partial fulfillment of the requirements for the award of degree of Master of Engineering in *Power Systems & Electric Drives* submitted in Electrical & Instrumentation Engineering Department of Thapar University, Patiala, is an authentic record of my own work carried out under the supervision of Ms Suman Bhullar.

The matter presented in this thesis has not been submitted for the award of any other degree of this or any other university.

(Navreet kaur)

This is to certify that the above statement made by the candidate is correct and true to the best of my knowledge.

(Ms Suman Bhullar)

Electrical & Instrumentation Engg. Department
Thapar University

Patiala

Countersigned by

(S. GHOSH)

Professor & Head

Electrical & Instrumentation Engg. Department
Thapar University
Patiala

(R.K. SHARMA)

Dean(Academic Affaris)

Thapar University,
Patiala.

ABSTRACT

Automatic generation control (AGC) plays a very important role in power system; its main role is to maintain the system frequency and tie line flow at their scheduled values during normal period in an interconnected system. This work presents the automatic generation control (AGC) of an interconnected two area system. For carrying out AGC for the two area system conventional and fuzzy logic controller is used in and change in generation in both the areas and change in overall frequency of the system is examined using MATLAB SIMULINK. Area Control Error (ACE) is measured and results of the conventional method and the fuzzy logic are compared. The aim of the proposed controller is to restore the frequency to its nominal value in the smallest possible time whenever there is any change in the load demand etc.

ACKNOWLEDGEMENT

First of all, I thank the Almighty God, who gave me the opportunity and strength to carry out this work.

I would like to thank **Ms. Suman Bhullar, Lecturer (EIED)** for the opportunity to work with her, and also for her encouragement, trust and untiring support. **Ms. Suman Bhullar** has been an advisor in the true sense both academically and morally throughout this project work.

Much appreciations is expressed to **Prof. Abhijit Mukherjee, Director, Thapar University, Prof. K.K. Raina, Deputy Director, Thapar University and Prof. R.K. Sharma, Dean of Academic Affairs** to provide me moral support to go ahead with my M.E. Thesis work.

I thank to **Dr. Smarajit Ghosh, Prof.& Head, EIED** and **all the faculty of EIED** for their continuous inspiration during this thesis work.

The paucity of words does not compromise for extending my thanks to my all family members and friends of M.E. (PSED) whose uninterrupted love, inspiration and blessings helped me in completing this research report.

I am also thankful to the authors whose work has been consulted, utilized and cited in my dissertation

Navreet Kaur
80641014

TABLE OF CONTENTS

	Page no.
Certificate	i
Acknowledgement	ii
Abstract	iii
List of figures	vi
List of tables	vii
Chapter1 Introduction	1
1.1 Automatic Generation Control	1
1.2 Literature review	4
1.3 Objective	9
1.4 Organization of thesis	9
Chapter 2	
2.1 Power system dynamics	10
2.2 Frequency response in primary control	10
2.3 AGC in secondary control	12
2.4 Area Control Error	13
2.5 Tie line bias control	14
2.6 AGC in a single area system	14
2.7 AGC for a two area system	16
chapter 3	
3.1 Fuzzy systems	21
3.1.1 Fuzzy versus crisp	21
3.1.2 Fuzzy logic	21
3.2 Fuzzy set theory	22
3.2.1 Classical sets	22
3.2.2 Membership Functions	23
3.3 Set operations	23
3.3.1 Complement	23
3.3.2 Union	24
3.3.3 Intersection	24
3.3.4 Cartesian products	24

3.3.5 Basic concept of fuzzy sets	24
3.4 Representations of Fuzzy sets	25
3.5 Determination of membership functions	27
3.6 Fuzzy set properties	27
3.7 Operations on fuzzy sets	28
3.8 Fuzzification	30
3.9 Classical reasoning	30
3.10 Fuzzy reasoning	31
3.11 Fuzzy Logic Controller	33
3.11.1 Design	33
Chapter 4	
4.1 Application of fuzzy logic control to Automatic Generation Control	36
4.1.1 Algorithm for application of fuzzy logic to AGC	36
4.1.2 Rule base	36
4.2 Results	38
Chapter 5	
5.1 Summary of major findings	42
5.2 Scope for future work	42
REFERENCES	43
APPENDICES	
Appendix – A List of symbols used	46
Appendix – B List of abbreviations used	47

LIST OF FIGURES

Figure 2.1 Ideal steady state characteristics of a governor with speed droop

Figure 2.2 Addition of integral control on generating units selected for AGC

Figure 2.3: Transfer function model of a two area interconnected system

Figure 3.1 commonly used membership functions

Figure 3.2 Basic structure of fuzzy logic controller.

Figure 4.1 Sub sets defining ACE

Figure 4.2 Subsets defining ΔF

Figure 4.3 Frequency deviation step response for area 1 and area 2 with conventional controller

Figure 4.4 Frequency deviation step response for area 1 and area 2 using fuzzy logic controller

Figure 4.5 Power deviation step response for area 1 and 2, and ΔP_{tie} using conventional controller

Figure 4.6 Power deviation step response for area 1 and 2, and ΔP_{tie} using fuzzy logic controller

LIST OF TABLES

Table 3.1 : Induction and deduction of rules

Table 4.1.2 : Rule base

Table 4.1.3 : Rule base

Table 4.2 Data set 1

Table 4.3 Results with data set 1

Table 4.4 Data set 2

Table 4.5 Results with data set 2

CHAPTER 1

INTRODUCTION

1.1 AUTOMATIC GENERATION CONTROL

When load in the system increases turbine speed drops before the governor can adjust the input. As the change in the value of speed decreases the error signal becomes smaller and the positions of governor valve get close to the required position, to maintain constant speed. However the constant speed will not be the set point and there will be an offset, to overcome this problem an integrator is added, which will automatically adjust the generation to restore the frequency to its nominal value. This scheme is called automatic generation control (AGC). The role of AGC is to divide the loads among the system, station and generator to achieve maximum economy and accurate control of the scheduled interchanges of tie-line power while maintaining a reasonable uniform frequency. Modern power system network consists of a number of utilities interconnected together and power is exchanged between utilities over tie-lines by which they are connected. Automatic generation control (AGC) plays a very important role in power system as its main role is to maintain the system frequency and tie line flow at their scheduled values during normal period.

Automatic generation control with primary speed control action, a change in system load will result in a steady state frequency deviation, depending upon governor droop characteristics and frequency sensitivity of the load. All generating units on speed governing will contribute to overall change in frequency, irrespective of the location of the load change. Restoration of the system frequency to nominal value requires supplementary control action which adjusts the load reference set point. Therefore the primary objectives of the automatic generation control are to regulate frequency to the nominal value and to maintain the interchange power between control areas at the scheduled values by adjusting the output of selected generators. This function is commonly referred to as load frequency control. A secondary objective is to distribute the required change in generation among the units to minimize the operating costs.

Generation in large interconnected power system comprises of thermal, hydro, nuclear, and gas power generation. Nuclear units owing to their high efficiency are usually kept at base load close to their maximum output with no participation in system automatic generation control (AGC). Gas power generation is ideal for meeting varying load demand. However, such plants do not play very significant role in AGC of a large power system, since these plants form a very small percentage of total system generation. Gas plants are used to meet peak demands only. Thus the natural choice for AGC falls on either thermal or hydro units. An interconnected power system can be considered as being divided into control areas which are connected by tie lines. In each control area, all generator sets are assumed to form a coherent group. The power system is subjected to local variations of random magnitudes and durations, Hence, it is required to control the deviations of frequency and tie-line power of each control area.

In actual power system operations, the load is changing continuously and randomly. As the ability of the generation to track the changing load is limited due to physical/technical considerations, there results an imbalance between the actual and the scheduled generation quantities. This imbalance leads to a frequency error i.e. the difference between the actual and the synchronous frequency. The magnitude of the frequency error is an indication of how well the power system is capable to balance the actual and the scheduled generation. The presence of an actual-scheduled generation imbalance gives rise initially to system frequency excursions in accordance to the sign of the imbalance and act to reduce the magnitude of actual-scheduled generation imbalance.

A control signal made up of tie line flow deviation added to frequency deviation weighted by a bias factor would accomplish the desired objective. This control signal is known as area control error (ACE). ACE serves to indicate when total generation must be raised or lowered in a control area.

In an interconnection, there are many control areas, each of which performs its AGC with the objective of maintaining the magnitude of ACE (area Control Error) “sufficiently close to 0” using various criteria. In order to maintain the frequency sufficiently close to its synchronous value over the entire interconnection, the coordination of the control areas’ actions is required. As each control area shares in the responsibility for load frequency control, effective

means are needed for monitoring and assessing each area's performance of its appropriate share in load frequency control.

Modern power system network consists of a number of utilities interconnected together and power is exchanged between utilities over tie-lines by which they are connected. Automatic generation control (AGC) plays a very important role in power system, its main role is to maintain the system frequency and tie line flow at their scheduled values during normal period. During large transient disturbance and emergencies AGC is bypassed and other emergency control takes over. The synchronization of different system to interconnected system depends upon (1) voltage magnitude (2) frequency and (3) phase sequence. Any wide deviation from the nominal value of frequency or voltage will lead the system to total collapse. Hence AGC has gained importance with the growth of interconnected systems and with rise in size of interconnected system automation of the control system have aroused. A number of control strategies exist to achieve better performance. Due to non-linearities of power system, system parameters are linearized around an operating point. PI controller is generally used. The disadvantage of PI controller is that the mathematical model of the control process may not exist or may be too expensive in terms of computer processing powers and memory.

Performance of AGC under normal and abnormal conditions

Under normal conditions with each area able to carry out its control obligations, steady state corrective action of AGC is confined to the area where the deficit or excess of generation occurs. Inter area power transfers are maintained at scheduled levels and system frequency is held constant.

Under abnormal conditions, one or more areas may be able to correct for the generation-load mismatch due to insufficient generation reserve on agc. In such an event, other areas assist by permitting the inter areas power transfers to deviate from scheduled values and by allowing system frequency to depart from its pre disturbance value. Each area participates in frequency regulation in proportion to its available regulating capacity relative to that of overall system.

Concept of fuzzy logic: The concept of fuzzy set theory was introduced by Zadeh in 1965 (Zadeh 1965) and it was first introduced in 1979 for solving power system problems. Fuzzy set theory can be considered as a generalization of the classical set

theory. In classical set theory an element of the universe either belongs to or does not belong to the set. Thus the degree of association of an element is crisp. In a fuzzy set theory the association of an element can be continuously varying. Mathematically, a fuzzy set is a mapping (known as membership function) from the universe of discourse to the closed interval $\{0, 1\}$. The membership function is usually designed by taking into consideration the requirement and constraints of the problem. Fuzzy logic implements human experiences and preferences via membership functions and fuzzy rules. Due to the use of fuzzy variables, the system can be made understandable to a non-expert operator. In this way, fuzzy logic can be used as a general methodology to incorporate knowledge, heuristics or theory into controllers and decision makers.

1.2 LITERATURE REVIEW

A lot of literature is available on this topic. Here is the literature survey that is relevant with the work carried out for this thesis work

According to J. Nanda and A. Mangla in paper ‘Automatic Generation Control of an Interconnected Hydro-Thermal System Using Conventional Integral and Fuzzy Logic Controller’ the presence of FLC(Fuzzy Logic Controller) in both areas and small step perturbation in either area or in both areas simultaneously provides better dynamic response than with conventional integral controller. Nominal parameter of hydrothermal system (R) is investigated: With FLC like in conventional integral controller, higher sampling period than the normally used in practice is permissible without deteriorating dynamic responses for all practical purposes. The number of triangular Membership Functions has an impact on dynamic responses and hence needs to be properly selected. [3]

In paper ‘Design and Experience with a Fuzzy Logic Controller for Automatic Generation Control (AGC)’ by G.A. Chown and R C. Hartman describes the design, implementation and operational performance of a fuzzy controller as part of the Automatic Generation Control (AGC) system in Eskom’s National Control Centre The fuzzy controller was implemented in the control ACE calculation, which determines the shortfall or surplus generation that has to be corrected. [9]

Li Pingkang and Ma Yongzhen has introduced some new concepts for automatic generation control in the paper ‘Some New Concepts in Modern Automatic Generation Control Realization’ According to the power system AGC practice demand, the high quality of the electric power demand could be satisfied by using the advanced computer technology, including hardware and software. New algorithm, such as feed forward or predictive with intelligent, will improve the control effort, and the interaction between power plant and power system. [18]

Bjorn H. Bakken and Ove S. Grande introduced two LFC schemes in this paper named Automatic Generation Control in a Deregulated Power System. One alternative is the general load-frequency control scheme. The LFC handles all system deviations; faults. Normal load changes and HVDC ramping. It will automatically adjust to any manual control actions taken. [6]

Ignacio Egido, Fidel Fernández-Bernal, Luis Rouco, Eloisa Porras, and Ángel Sáiz-Chicharro have purposed the ‘Modelling of Thermal Generating Units for Automatic Generation Control Purposes’ The model used for analysis has been obtained after analyzing the real response of 14 thermal units. The model consists of a rate limiter, a dead band, a second-order discrete linear transfer function and an offset. This procedure uses real data obtained both from a step response test and an historical behaviour of the unit. Results obtained for a coal fired unit and a fuel/gas fired unit has also been presented. [14]

Manoranjan Paridal; J. Nanda describes the application of AGC in paper ‘Automatic Generation Control of a Hydro-Thermal System in Deregulated Environment’ with deregulated power system and makes a maiden attempt to provide a new practical AGC model to cater to the needs of a modern restructured hydrothermal power system. [15]

Barjeev Tyagi, Student Member, IEEE, and S. C. Srivastava, Senior Member, IEEE purposed in paper ‘A Decentralized Automatic Generation Control Scheme for Competitive Electricity Markets’ the design of a decentralized automatic generation control (AGC) scheme for interconnected multiarea power system. [5]

‘Some New Findings on Automatic Generation Control of an Interconnected Hydrothermal System With Conventional Controllers’ Janardan Nanda, Senior Member, IEEE, Ashish Mangla, and Sanjay Suri in this paper deals with automatic generation control of an interconnected hydrothermal system in continuous-discrete mode using conventional integral and proportional-integral controllers. Appropriate generation rate constraint has been considered for the thermal and hydro plants. [16]

Noureddine Bekhouche and Ali Feliachi presented an algorithm in ‘Decentralized estimation for the automatic generation control problem in power systems’ for a decentralized estimation and its application to Automatic Generation Control (AGC) as the Load Frequency Control (FLC) problem in power systems. The variables to be estimated are the frequency deviations and the tie line power deviations for multiarea power systems. [22]

‘Automatic generation control with fuzzy logic controller in the power system including three areas’ by Engin Yesil, Aysen Demiroren, Erkin Yesil presents a method based on fuzzy logic controllers (FLCs) for automatic generation control (AGC) of power system including three areas having two steam turbines and one hydro turbine tied together through power lines. The results obtained by using FLCs proposed in this paper outperform than those of conventional controllers. [8]

‘Application of fuzzy controlled smes unit in automatic generation control’ by M. G. Rabbani, M. F. Hossain, M. R. I. Sheikh and M. S. Anower describes the application of fuzzy logic control in an Automatic Generation Control (AGC) of an isolated power system that uses a 12-pulse bridge converter associated with Superconducting Magnetic Energy Storage Unit. A systematic approach for designing the fuzzy logic controller (FLC) is proposed in this paper. [20]

Automatic generation control of a multi-area power system with conventional integral controllers carried out by J. Nanda, Fellow IEEE; M. Parida, A. Kalam deals with automatic generation control (AGC) of a multi-area hydrothermal system. Appropriate generation rate constraints have been considered for the thermal and hydro plants. The hydro area is considered with an electric governor and thermal area is considered with reheat turbine. Optimization of integral controllers and electric governor parameters has been carried out using integral squared error (ISE) criterion. [17]

Nasser Jaleeli, Donald N. Ewart, Lester H. Fink, Arthur G. Hoffmann describes in the paper 'Understanding automatic generation control' what automatic generation control (AGC) might be expected to do, and what may not be possible or expedient for it to do. The purposes and objectives of AGC are limited by physical elements involved in the process and, hence, the relevant characteristics of these elements are described. [23]

In 'Intelligent controllers for automatic generation control given by D.M. Vinod Kumar presented a novel approach of Artificial Intelligence (AI) techniques viz., Fuzzy logic, Artificial Neural Network (ANN) and Hybrid Fuzzy Neural Network (HFNN) for the Automatic Generation Control (AGC). The limitations of the conventional controls viz., Proportional, Integral and Derivative (PID) are slow and lack of efficiency in handling system non-linearities. The primary purpose of the AGC is to balance the total system generation against system load and losses so that the desired frequency and power interchange with neighbouring systems are maintained. [7]

G.L Kusic, J.A. Sutterfield, A. R. Caprez, J. L. Haneline, B. R. Bergman in 'Automatic generation control for hydro systems' gives information about Modern Automatic Generation Control (AGC) sample tie line real power flows, line frequency, and generator power outputs. These analog signals are usually measured two second periodically and combined with desired interchange to obtain the Area Control Error (ACE). [10]

M.S. Anower, MG. Rabbani, M.F. Hossain, M.R.I Sheikh and M Rakibul Islam in paper 'Fuzzy frequency controller for the improvement of power systems dynamics' proposed a Fuzzy Frequency Controller (FFC) to improve the dynamic performance of a single-area power system. This paper represents the implementation of Fuzzy Frequency Controller for an AGC in single-area power system. The aim of the proposed controller is to restore the frequency to its nominal value in the smallest possible time whenever there is any change in the load demand etc. [21]

George Gross and Jeong Woo Lee presented the development and application of an analytic framework for the formulation and evaluation of control performance criteria in load frequency control (LFC) in paper 'Analysis of Load Frequency Control Performance Assessment Criteria.' The framework is constructed so as to explicitly represent the uncertainty in the measured variables in LFC and to use metrics that are meaningful for the structure of the problem. The framework makes effective use of probability and random processes concepts to develop rather general criteria for LFC performance assessment. [11]

'M.F. Hussein T. Takahashi M.G. Rabbani M.R.I. Sheikh T M.S. Anower in the present work,' Fuzzy-Proportional Integral Controller for an AGC in a Single area power system' presented the intelligent load frequency controllers have been developed to regulate the power output and system frequency by controlling the speed of the generator with the help of fuel rack position control. This paper presents the implementation of Fuzzy-Proportional Integral controller (FPIC) for controlling AGC in a single area power system. [19]

In 'Frequency stabilization using fuzzy logic based controller for multi-area power system' by H.D. Mathur and H.V. Manjunath proposed a fuzzy logic controller for load frequency control problem of electrical power system. The fuzzy controller is constructed as a set of control rules and the control signal is directly deduced from the knowledge base and the fuzzy inference. The study has been designed for a two area interconnected power system. [12]

A K Swain discussed in paper 'A Simple Fuzzy Controller for Single Area Hydro Power System Considering Generation Rate Constraints'. The performance of the simplest fuzzy controller, which resembles a variable gain nonlinear proportional-integral (PI) controller, is compared with an implicit self-tuning controller (STC) with integral feature considering an example of single area hydro-power system with generation rate constraint. The robust feature of these controllers against certain significant parameter variations, such as, the inertia constant (H) and the self regulation parameter (R) of the governor have been investigated. [2]

1.3 OBJECTIVE

Automatic Generation Control of a two area interconnected system is carried out in this work.

Change in frequency and generation in each area with load change in any of the two area is measured. Area Control Error is measured by using conventional method and fuzzy logic. Fuzzy logic is applied to calculate ACE (out) i.e. the control signal provided to each area so that its area control error can be minimized.

Frequency response of two area interconnected system is investigated using MATLAB SIMULINK models for load change in the system both with Fuzzy Logic Controller and without Fuzzy Logic Controller and comparison of the results deduced is done.

1.4 ORGANIZATION OF THE THESIS

First chapter includes brief outline of the thesis.

Second chapter constitutes the basic theory of a power system for automatic generation control and formulation of AGC carried out for a two area interconnected system.

Third chapter includes theory of fuzzy logic which consists of basic sets and fuzzy sets and operations performed on them, inference from rules. Fuzzification, building up of rules and defuzzification.

Fourth chapter includes algorithm for application of fuzzy logic to AGC, rule base, data used for the problem and results.

Fifth chapter includes major findings of the work and future scope of this work.

Appendix – A List of symbols used

Appendix – B List of abbreviations used.

2.1 Power system dynamics

The operating condition of a power system is continuously varying because of the disturbances from the time varying loads or circuit changes in the network. Temporarily imbalance is met by the changes in the kinetic energy of the rotating inertias of generators and motors. Any change in frequency, in turn, will affect frequency sensitive load. If equilibrium is reached, the change in frequency will be halted in a new system frequency usually in several seconds. Following the primary is the secondary control of the automatic generation control of the control areas which will collectively attempt to adjust its generation to restore system frequency to nominal values, while maintaining scheduled power transfer between the areas.

2.2 Frequency response in primary control

When the system frequency drifts from nominal value 50Hz, some frequency sensitive components react to this change. First, the effective load for the power system changes. This process is called load damping and modelled with damping factor D. second, if the system frequency goes beyond the governor dead band (about $\pm 35\text{mHz}$); the governor will act to increase or decrease the output power of generating units. This can be done with the help of governed speed droop R, which is actually the feedback loop gain in the governor. The speed droop is defined as

$$R = \frac{\Delta\omega}{\Delta P} \text{ pu}$$

Where

$\Delta\omega$ = speed deviation

ΔP = output power

Percent speed regulation or droop R

The value of R determines the steady state speed versus load characteristics of the generating unit as shown in figure 2.1 below.

The ratio of speed deviation (Δw_r) or frequency deviation (Δf) to change in valve/gate position (ΔY) or output power (ΔP) is equal to R. the parameter R is referred to speed regulation or droop. It can be expressed in percent as

$$\text{Percent R} = \frac{\text{percent speed or frequency change}}{\text{percent power output change}} * 100$$

$$= \frac{w(nl) - w(fl)}{w_0} * 100$$

where

w (nl) = steady state speed at no load

w (fl) = steady state speed at full load

w₀ = nominal or rated speed

for example 5% speed droop or regulation means 5% frequency deviation causes 100% change in power output.

In figure 2.1 speed droop characteristics of governor is shown. A typical value of speed droops in the governor is 5%. These governors' responses from each unit in the control area collectively to stabilize the system frequency at a new equilibrium.

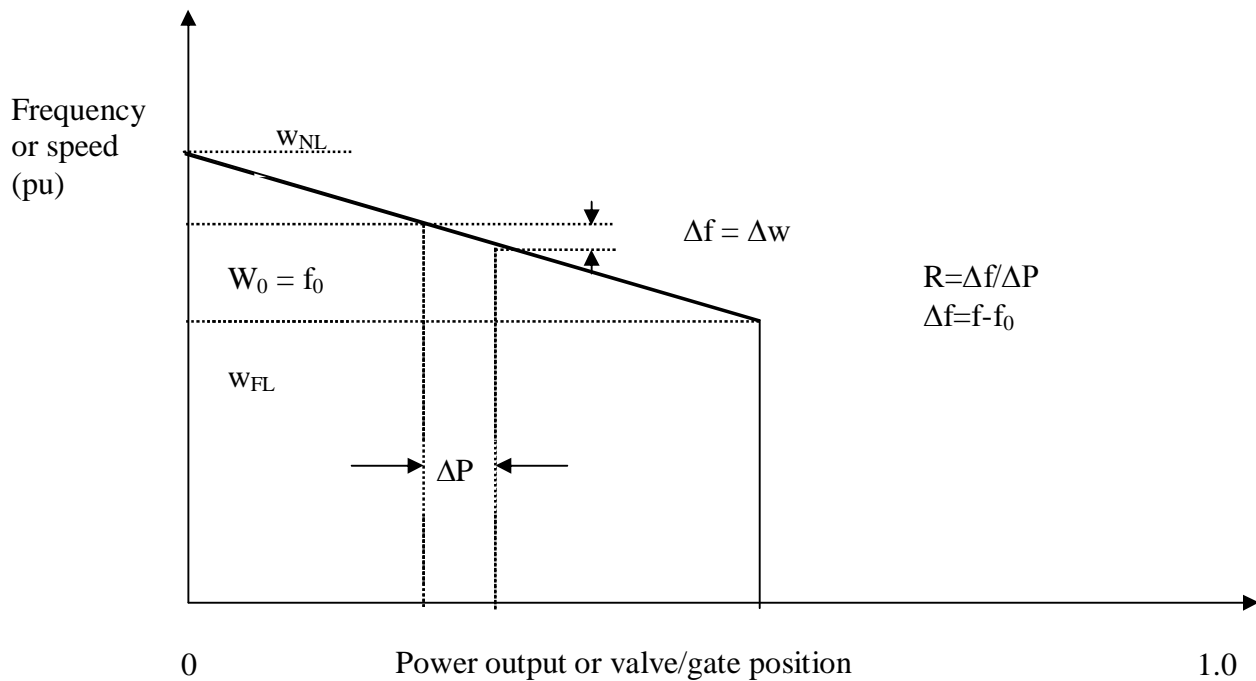

Figure. 2.1 Ideal steady state characteristics of governor with speed droop

These two responses, load damping and governor response; help the system interconnection to be more stable. In short the system frequency goes up when the generation output is relatively bigger than the loads and the vice versa. This can be understood as a strong natural inertia to stay on equilibrium. the governor speed droop characteristics intentionally put to help this natural process to be more effective. These responses are mathematically modelled as D and R respectively and are combined into one frequency response characteristic β .

$$\beta = \sum \left(\frac{1}{R} + D \right)$$

2.3 AGC in secondary control

For normal disturbances, the primary control action will arrest the frequency deviation to a new frequency above or below the rated value. The secondary control is following up to return the frequency to the nominal value. This follow up control action can be manual or automatic. An automatic secondary control is conventionally referred to as Automatic Generation Control (AGC).

AGC is major control function of secondary control within a utility energy control centre, whose purpose is the tracking of load variations to maintain system frequency at its nominal value, net tie line interchanges to its scheduled values, and optimal generation levels, close to its most economical points.

These objectives can be summarized as:

- (i) To hold system frequency at or very close to a specified/nominal value.
- (ii) To maintain correct value of interchange power between control areas
- (iii) To maintain each units generation at the most economic value.

To accomplish these objectives, each control area has to continually determine and monitor system deviation in measured frequency, Δf and tie line flow, ΔT , to determine the Area Control Error (ACE) as a measure for the secondary control. The raw values of ACE is first processed through filters, and then pass through a PI regulator, distributed by regulation participation factors before being dispatched as the load reference signal to the governor of units. A demand signal may also be sent to coordinate boiler turbine controllers to initiate boiler action in advance for improved overall unit response. The response time of AGC is approximately, a minute or two, mainly limited by the delays associated with the response rate of the units.

2.4 Area Control Error

Area Control Error is defined by

$$ACE_i = \Delta P_{ij} + B_i * \Delta f$$

Where i control area for which ACE is being measured

ΔP_{ij} power interchange in areas i and j

B_i control area frequency bias coefficient

Δf deviation in frequency

ACE is an error signal consisting of two terms. First term represents the error in the scheduled tie flows. The second term is inter area assistance in generation from

control area to prevent large deviation of interconnection frequency. ACE, as defined, represents the generation versus load mismatch for the control area. The ACE signal is used in conventional AGC which has a PI control logic.

ACE serves to indicate when total generation must be raised or lowered in a control area. A general criterion can be given about which AGC is considered 'good':

- The ACE signal should ideally be kept from becoming too large. Since ACE is directly influenced by random load variations, this criterion can be treated statically by saying that the standard deviation of ACE should be small
- ACE should not be allowed to 'drift'. This means that the integral of ACE over appropriate time should be small. A 'drift' in ACE has the cumulative effect of creating system time errors or inadvertent interchange errors.
- The amount of control action called for by the AGC should be kept to a minimum. [25]

2.5 Tie line bias control

Tie-line bias control is a control philosophy developed for load frequency control in a power system. It is widely used in AGC. It has been proved efficient in maintaining interconnection reliability and its simplicity in control implementation. The concept allows each control area to operate its generation and to fulfil areas control obligation, independently by monitoring and control the area's ACE.

The frequency bias term in the ACE equation is important in that it assures that the objective of the AGC regulation is fulfilled while an area's responsibility to provide frequency response is not forfeited. Part of the inter area tie flow from the area's frequency response is compensated by the bias term. It helps the area to avoid to respond to external disturbance. [25]

2.6 AGC in a single area system

In an isolated power system, maintenance of interchange power is not an issue. Therefore, the function of AGC is to restore frequency to the specified nominal value. This is accomplished by adding a reset or integral control which acts on the load

reference settings of the governors of units on AGC. The integral control action ensures zero frequency error in the steady state.

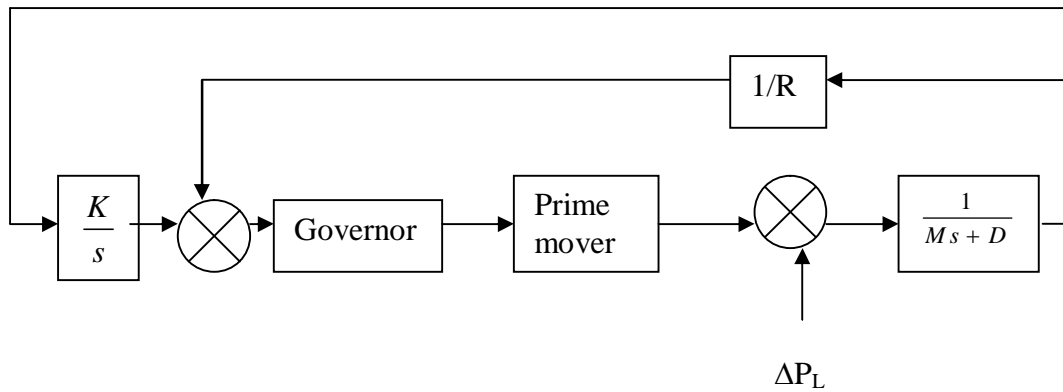

Figure 2.2 Addition of integral control on generating units selected for AGC

The supplementary generation control action is much slower than the primary speed control action. As such it takes effect after the primary speed control (which acts on all units on regulation) has stabilized the system frequency. Thus, AGC adjusts load reference settings of selected units, and hence their output power, to override then effects of composite frequency regulation characteristics of power system. In doing so, it restores the generation of all other units not on AGC to scheduled values [1]

2.7 AGC for a two area system

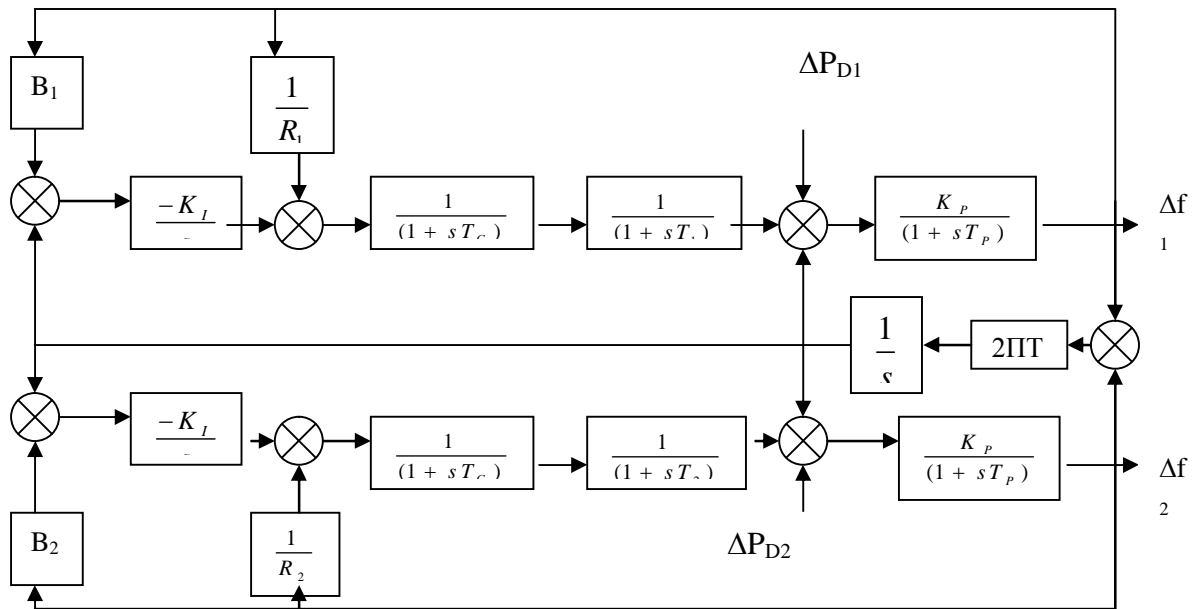

Figure 2.3 Transfer function model of a two area interconnected system

ΔP_{D1} Incremental load change in area 1.

ΔP_{D2} Incremental load change in area 2

R Governor speed regulation parameter.

TG Mechanical governor response time, second.

T_1 turbine time constant.

B_1 Frequency bias constant for area 1.

B_2 Frequency bias constant for area 2

$T_P = 2H/fD$

$K_P = 1/D$

D load damping constant

K_I Integral gain

Δf_1 Change in frequency for area 1

Δf_2 Change in frequency for area 2

Figure 2.3 below shows block diagram representation of a two area interconnected system with each area represented by an equivalent inertia M, load damping constant

D, turbine and governing system with a an effective speed droop R. The power flow on tie line from area 1 to area 2 is

$$P_{12} = \frac{E_1 E_2}{X_T} \sin(\delta_1 - \delta_2) \quad (2.1)$$

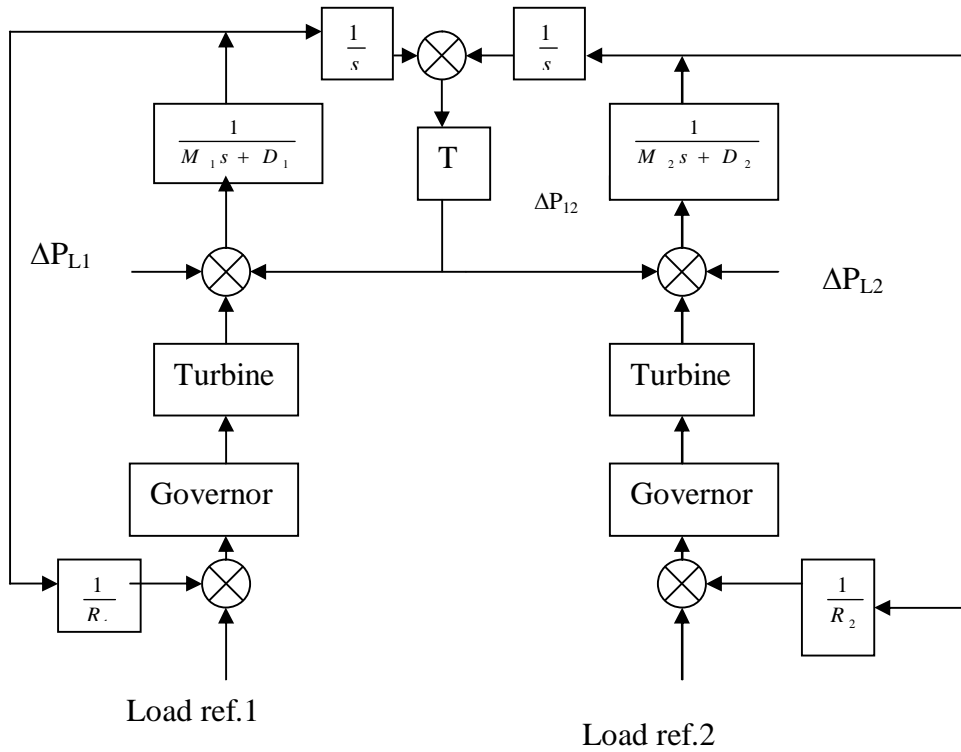

Figure 2.3 Two area system with primary speed control

Linearizing about an initial operating point represented by $\delta_1 = \delta_{10}$ and $\delta_2 = \delta_{20}$

$$\text{And } \Delta P_{12} = T \Delta \delta_{12} \quad (2.2)$$

$$\text{Where } \delta_{12} = \Delta \delta_1 - \Delta \delta_2 \quad (2.3)$$

The tie line is represented by the synchronising torque coefficient T. synchronizing coefficient T is given by

$$T = \frac{E_1 E_2}{X_T} \cos(\delta_{10} - \delta_{20}) \quad (2.4)$$

A positive ΔP_{12} represents an increase in power transfer from area 1 to area2.

The steady state frequency deviation (f-f₀) the same for two areas. For a total load change of ΔP_L ,

$$\Delta f = \Delta \omega_1 = \Delta \omega_2 = \frac{-\Delta P_L}{(1/R_1 + 1/R_2) + (D_1 + D_2)} \quad (2.5)$$

consider the steady state values following an increase in area 1 load by ΔP_{L1} . for area 1

$$\Delta P_{m1} - \Delta P_{12} - \Delta P_{L1} = \Delta f D_1 \quad (2.6)$$

and for area 2

$$\Delta P_{m2} + \Delta P_{12} = \Delta f D_2 \quad (2.7)$$

the change in mechanical power depends upon regulation. Hence,

$$\Delta P_{m1} = -\frac{\Delta f}{R_1} \quad (2.8)$$

$$\Delta P_{m2} = -\frac{\Delta f}{R_2} \quad (2.9)$$

substitution of equation (2.8) in eq. (2.6) and eq. (2.9) in eq. (2.7) yields

$$\Delta f \left(\frac{1}{R_1} + D_1 \right) = \Delta P_{12} - \Delta P_{L1} \quad (2.10)$$

$$\text{and} \quad \Delta f \left(\frac{1}{R_2} + D_2 \right) = \Delta P_{12} \quad (2.11)$$

solving equations (2.10) and (2.11)

$$\Delta f = \frac{-\Delta P_{L1}}{(1/R_1 + 1/R_2) + (D_1 + D_2)} = \frac{-\Delta P_{L1}}{\beta_1 + \beta_2} \quad (2.12)$$

$$\Delta P_{12} = \frac{-\Delta P_{L1}(1/R_2 + D_2)}{(1/R_1 + D_1)(1/R_2 + D_2)} = \frac{-\Delta P_{L1}\beta_2}{\beta_1 + \beta_2} \quad (2.13)$$

where β_1 and β_2 are the composite frequency response characteristics of area1 and area2 respectively.

An increase in area 1 load by ΔP_{L1} results in a frequency reduction in both areas and a tie line flow of ΔP_{12} . a negative ΔP_{12} is indicative of flow from area 2 to area1. the tie line flow deviation reflects the contribution of the regulation characteristic $(1/R+D)$ of one area to another.

Similarly for a load change in area 2 by ΔP_{L2}

$$\Delta f = \frac{-\Delta P_{L2}}{\beta_1 + \beta_2} \quad (2.14)$$

and

$$\Delta P_{12} = -\Delta P_{21} = \frac{-\Delta P_{L2}\beta_1}{\beta_1 + \beta_2} \quad (2.15)$$

examination of equations from (2.10) to (2.13) indicates a control signal made up of tie line flow deviation added to frequency deviation weighted by a bias factor would accomplish the desired objective. This control signal is known as area control error (ACE). [25]

from equation (2.10) and (2.11), it is apparent that a suitable bias factor for an area is its frequency response characteristic β .

Thus area control error for area 2

$$ACE_2 = \Delta P_{12} + B_2 \Delta f \quad (2.16)$$

Where

$$B_2 = \beta_2 = \frac{1}{R_2} + D_2 \quad (2.17)$$

Similarly for area 1

$$B_1 = \beta_1 = \frac{1}{R_1} + D_1 \quad (2.18)$$

The ACE represents the required change in area generation, and its unit is MW. The unit normally used for expressing the frequency bias factor B is mW/0.1Hz.

Economic allocation of generators

An important secondary function of Automatic Generation Control is to allocate generation so that each power source is loaded most economically. This function reoffered to as economic dispatch control. The theory of economic dispatch is based on principle of equal incremental costs.

For control of tie line power and frequency, it is necessary to send signals to generating plants to control generation. It is possible to use these signals to control generation to satisfy economic dispatch criteria. Thus the requirements for EDC can be handled as a part of the AGC function. Since system load is continually changing, economic dispatch calculations have to be made at frequent intervals

The allocation of individual generator output over a range of total generation values is accomplished using base points and participation factor. The economic dispatch calculation is executed with a total generation equal to the sum of the present values of unit generation as measured. The result of this calculation is a set of base point generations, P_{ibase} , which is equal to the most economic output for each generator unit. The rate of change of each unit's output with respect to change in total generation is called the units participation factor, pf . The base point and participation factors are used as follows:

$$P_{ides} = P_{ibase} + pf_i * \Delta P_{total}$$

Where

$$\Delta P_{total} = P_{new total} - \sum P_{ibase}$$

and

P_{ides} = new desired output from unit i

P_{ibase} = base point generation from unit i

Pf_i = participation factor for unit i

ΔP_{total} = change in total generation

$P_{new total}$ = new total generation

3.1 FUZZY SYSTEMS

3.1.1 Logic

Logic is the science of reasoning. Symbolic or mathematical logic has turned out to be powerful computational paradigm. Not only symbolic logic help in the description of events in the real world but has also turn out to be an effective tool for inferring or deducing information from a given set of facts.

3.1.2 Fuzzy versus crisp

Consider the query “Is water colourless?” The answer to this is a definite yes/true or no/false as warranted by the situation. If “yes/true” is accorded a value of 1 and “no/false” is accorded value of 0, this statement results in a 0/1 type situation. Such a logic which demands a binary (0/1) type of handling is termed crisp in the domain of fuzzy set theory. Thus statement such as “temperature is 32 °C”, “the running time of program is 4 seconds” are examples of crisp situations.

On the other hand consider the statement, “is Ram honest?” The answer to this query need not to be definite “yes” or “no”. considering the degree to which one know Ram, a variety of answers spanning a range such as “extremely honest”, “extremely dishonest”, “honest at times”, “very honest” could be generated. If for instance, “extremely honest” were to be accorded a value of 1, at the high end of spectrum of value “extremely dishonest” a value of 0 at the low end of the spectrum then “honest at the times” and “very honest” could be assigned value of 0.4 and 0.85 respectively. So the situation is that it can accept values between 0 and 1. Such a situation is termed fuzzy.

3.1.2 Fuzzy logic

An objective of fuzzy logic has been to make computers think like people. Fuzzy logic can deal with the vagueness intrinsic to human thinking and natural language and recognizes that its nature is different from randomness. Using fuzzy logic algorithms could enable machines to understand and respond to vague human

concepts such as hot, cold, large, small, etc. It also could provide a relatively simple approach to reach definite conclusions from imprecise information.

Almost every application, including embedded control applications, could reap some benefits from fuzzy logic. Its incorporation in embedded systems could lead to enhanced performance, increased simplicity and productivity, reduced cost and time to- market, along with other benefits. Fuzzy logic has the advantage of modelling complex, nonlinear problems linguistically rather than mathematically and using natural language processing (computing with words). The use of fuzzy logic requires, however, the knowledge of a human expert to create an algorithm that mimics his/her expertise and thinking. Also, studying the stability of a fuzzy system is a demanding task. [24]

3.2 FUZZY SET THEORY

3.2.1 Classical sets

A set is defined as a collection of objects that may share certain characteristics. For example, one may define a set of positive integers, a set of students with passing grades, and a set of honest politicians. Each individual object is referred to as an element or member of the set. In a classical set an object x is either a member of a given set A (expressed as $x \in A$) or not a member (expressed as $x \notin A$); partial membership is not allowed.

There are numerous ways to define a set:

- One may specify the properties of its elements. For example, $A = \{x|x \text{ is an odd number } <10\}$
- One may list all the members of the set. For example,
 $A = \{1, 3, 5, 7, 9\}$
- One may use a formula to define the set. For example,
 $A = \{x_i = x_i + 1, i = 1, \dots, 5, \text{ where } x_i = 1\}$
- the set could also be defined as the result of a logical operation. For example,
 $A = \{x|x \text{ is an element that belongs to B OR C}\}$

3.2.2 Membership function

■ a membership function, μ , can be used to define a set.

$\mu_A(x) = 1$ if $x \in A$, and

$\mu_A(x) = 0$ if $x \notin A$ for all values of x .

Let all the numbers under consideration, i.e. the universe of discourse, be defined as $\{1, 2, 3, 4, 5, 6, 7, 8, 9, 10\}$.

Then, the set of odd numbers can be expressed as

$\{(1,1), (2,0), (3,1), (4,0), (5,1), (6,0), (7,1), (8,0), (9,1), (10,0)\}$.

Where each member of the universe of discourse is associated with a membership value in the form $(\#, \mu)$. The numbers 1, 3, 5, 7, and 9 are associated with $\mu = 1$ because they form the set of odd numbers extracted from the universe of discourse.

This method of defining a set can be easily extended to define a fuzzy set by allowing partial membership.

3.2.3 Universal Set

The set that consists of all the elements of interest for a particular application (the universe of discourse) is referred to as the universal set. It is the mother of all sets; any set that is not a universal set is a subset. One may write $A \subset I$ to mean that a set A (any set) is actually a subset of the universal set I .

3.3 Set Operations

Sets can be manipulated through numerous operations such as the complement, union, intersection, subtraction, and cartesian product. These will be defined and explained in the following sections.

3.3.1 COMPLEMENT

The COMPLEMENT, or ABSOLUTE COMPLEMENT of a given set A is denoted by A^c . It is defined by

$A^c = \{x \mid x \in I \text{ and } x \notin A\}$.

It is demonstrated graphically in Figure 2.1.

If the membership function of set A is $\mu_A(x)$ and that of \bar{A} is $\mu_{\bar{A}}(x)$, then one can write

$$\mu_{\bar{A}}(x) = 1 - \mu_A(x) .$$

3.3.2 UNION

The UNION of sets A and B is defined by

$$A \cup B = \{ x | x \in A \text{ or } x \in B \} .$$

3.3.3 INTERSECTION

The INTERSECTION of sets A and B is defined by

$$A \cap B = \{ x | x \in A \text{ and } x \in B \} .$$

Let $A = \{1, 2, 3, 4, 5, 6\}$ and $B = \{2, 4, 6, 8, 10\}$, then

$$A \cap B = \{2, 4, 6\} .$$

3.3.4 Cartesian Product

The Cartesian product of sets A and B is defined as $A \times B = \{(a,b) | a \in A, b \in B\}$.

3.3.5 Basic Concepts of Fuzzy Sets

A fuzzy set is a set where degrees of membership between 1 and 0 are allowed; it allows partial membership. Fuzzy sets can thus better reflect the way intelligent people think. For example, an intelligent person will not classify people as either friends or enemies; there is a range between these two extremes. Not recognizing that there are degrees in every trait can lead to erroneous decisions.

Vague human expressions such as tall, hot, cold, etc. can be expressed by fuzzy sets of the form

$$A = \{(x, \mu_A(x)) | x \in X\}$$

where X represents the universe of discourse and $\mu_A(x)$ assumes values in the range from 1 to 0.

Let the values of temperature in °C under consideration be

$$T = \{0, 5, 10, 15, 20, 25, 30, 35, 40\} .$$

Then, the term hot can be defined by a fuzzy set as follows

$$\text{HOT} = \{(0,0), (5,0.1), (10,0.3), (15,0.5), (20,0.6), (25,0.7), (30,0.8), (35,0.9), (40,1.0)\}.$$

This fuzzy set reflects the point of view that 0 °C is not hot at all, 5, 10, and 15 °C are somewhat hot, and 40 °C is indeed hot. Another person could have defined the set differently.

3.4 Representations of Fuzzy Sets

Fuzzy sets can be described in numerous ways; all of them allow partial membership to be expressed. The ordered pair method introduced in the previous section appears in a different format as follows

$$A = \mu_1 / x_1 + \mu_2 / x_2 + \mu_3 / x_3 + \dots$$

The symbol / here does not denote division, nor does the symbol + denote summation. The summation symbol is used to connect the terms and thus it means a union of single-term subsets.

Let $X = \{ x_1, x_2, x_3, x_4 \}$. One can define a fuzzy set as:

$$A = 0.8/x_1 + 0.4/x_2 + 0.1/x_3 + 0.9/x_4.$$

Fuzzy sets can also be defined by assigning a continuous function to describe the membership either analytically or graphically. Some commonly used membership functions are illustrated in Figure 3.1. The triangular membership function in Figure 3.1-a can also be expressed as

$$\begin{aligned} \mu(x) &= a (b-x)/(b-c) ; b \geq x \leq c \\ &= a (d-x)/(d-c); c \geq x \leq d \\ &= 0; \text{otherwise} \end{aligned}$$

The trapezoidal function shown in Figure 2.8-b can be expressed as:

$$\begin{aligned} \mu(x) &= a (b-x)/(b-c); b \geq x \leq c \\ &= a; c \geq x \leq d \\ &= a (e-x)/(e-d); d \geq x \leq e \\ &= 0; \text{otherwise} \end{aligned}$$

The Gaussian function of Figure 3.1 (c) can be expressed as:

$$\mu(x) = a \exp(-x-b)^2 / 2\sigma^2)$$

(a)

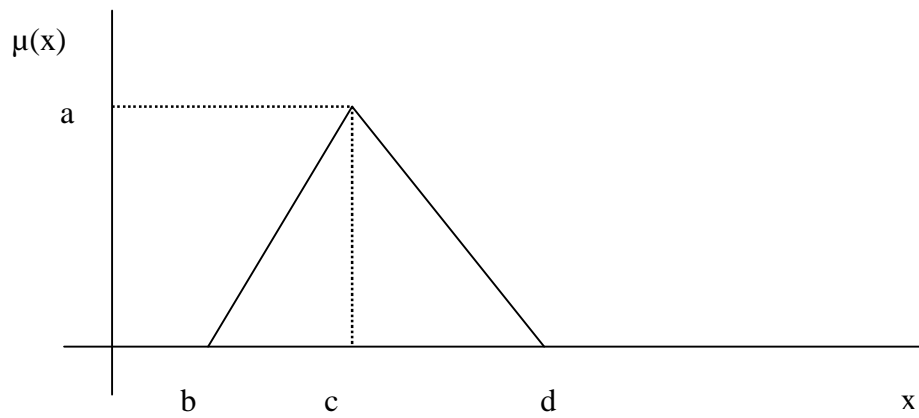

(b)

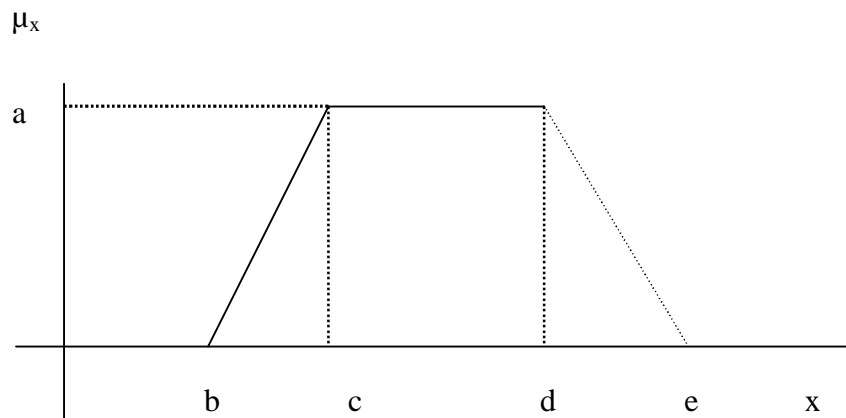

(c)

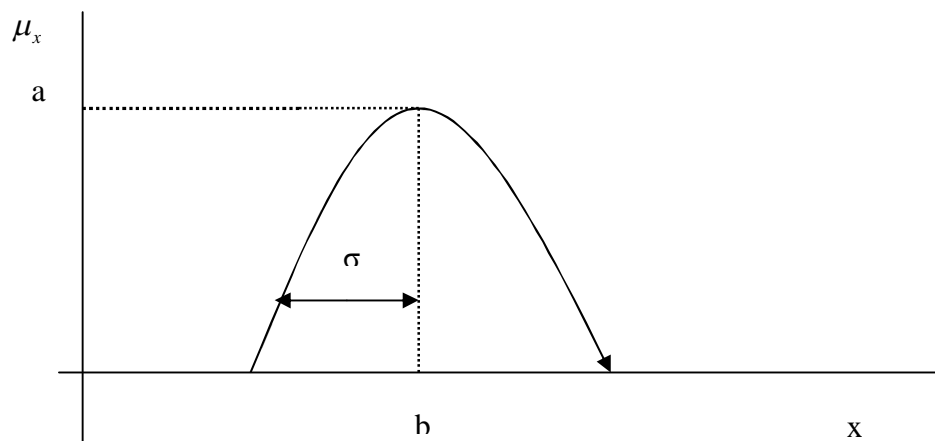

Figure 3.1 Commonly used membership functions

- (a) triangular membership function
- (b) trapezoidal membership function
- (c) Gaussian membership functions

3.5 Determination of Membership Functions

Discrete and continuous membership functions of a fuzzy set are intended to capture a person's thinking. The fuzzy set in the example of Section 2.5 was defined based on one's thinking of what coldness is. Fuzzy membership functions can still be determined subjectively in practical problems based on an expert's opinion. In such a situation one can think of membership functions as a technique to formalize empirical problem solving that is based on experience rather than the knowledge of theory. The expert's way of thinking can be captured either directly or through a special algorithm. Such determination could become more focused by physical measurements if the need arises. Available frequency histograms and other probability data can also help in constructing the membership function. It is important, however, to note that membership function values, or grades of membership, are not probabilities and they do not have to add to 1. Membership construction can be further simplified by selecting their form from the smaller family of the commonly used ones, such as those shown in Figure 3.1.

3.6 Fuzzy Sets Properties

3.6.1 Empty fuzzy set

A fuzzy set is referred to as empty if and only if the value of the membership function is zero for all possible members under consideration. In a short hand form this statement would read

$A = \emptyset$ iff $\mu_A(x) = 0 \forall x \in X$. (iff and \forall are short hand forms for if and only if and for all values of, respectively).

3.6.2 Universal fuzzy Set

A fuzzy set is universal if and only if the value of the membership function is one for all members under consideration.

3.7 Operations on Fuzzy Sets

Logic Operations

The three basic logic operations on classical (crisp) sets were introduced in Section 3.3. The definitions of sets were generalized leading to fuzzy sets upon which similar operations can be performed. The generalizations of operations on sets to operations on fuzzy sets are not unique. The ones introduced here are referred to as the standard fuzzy set operations. They are the operations most commonly used in engineering applications.

3.7.1 COMPLEMENT

The absolute complement of a fuzzy set A is denoted by \bar{A} and its membership function is defined by

$$\mu_{\bar{A}}(x) = 1 - \mu_A(x) \quad \text{for all } x \in X$$

.

3.7.2 UNION

The union of two fuzzy sets A and B is a fuzzy set whose membership function is defined by

$$\mu_{A \cup B}(x) = \max [\mu_A(x), \mu_B(x)]$$

3.7.3 INTERSECTION

The intersection of two fuzzy sets A and B is a fuzzy set whose membership function is defined by

$$\mu_{A \cap B}(x) = \min [\mu_A(x), \mu_B(x)]$$

3.7.4 Algebraic Operations on Fuzzy Sets

3.7.4.1 Cartesian multiplication

The Cartesian multiplication of two sets A and B is a fuzzy set C such that

$$C = A \times B$$

$$= \{ \mu_C(x) / (a, b) \mid a \in A, b \in B, \mu_C(c) = \min [\mu_A(a), \mu_B(b)] \}$$

Let $A = 0.2/3 + 1/5 + 0.5/7$, and

$B = 0.8/2 + 0.3/6$.

Then,

$$\begin{aligned} A \times B &= \min[0.2,0.8]/(3,2) + \min[0.2,0.3]/(3,6) \\ &+ \min[1,0.8]/(5,2) + \min[1,0.3]/(5,6) \\ &+ \min[0.5,0.8]/(7,2) + \min[0.5,0.3]/(7,6) \\ &= 0.2/(3,2) + 0.2/(3,6) + 0.8/(5,2) + 0.3/(5,6) \\ &+ 0.5/(7,2) + 0.3/(7,6). \end{aligned}$$

3.7.4.2 Algebraic multiplication

The algebraic product of two fuzzy sets A and B leads to a fuzzy set C such that $AB = \{\mu_A(a), \mu_B(b) | x \in A, x \in B\}$.

Let $A = 0.2/3 + 1/5 + 0.5/7$, and

$B = 0.1/3 + 0.3/7 + 0.2/8$.

Then, $AB = (0.2)(0.1)/3 + (1)(0)/5 + (0.5)(0.3)/7 + (0)(0.2)/8$
 $= 0.02/3 + 0.15/7$

As pointed out earlier, a fuzzy set A can be expressed as a linguistic concept such as hot, cold, young, old, etc. The result of using nested linguistic modifiers such as very, very very, etc. can be expressed using A^a

3.8 FUZZIFICATION

Fuzzification is the operation of transforming a crisp set to a fuzzy set, or a fuzzy set to a fuzzier set. The operation translates crisp input or measured values into linguistic concepts. This, in a way, is similar to what people may do in numerous situations to reach a decision. For example, if one is told that the temperature is going to be 10 °C, one translates this crisp input value into a linguistic concept such as mild, cold, or warm according to one's inclination, then reaches a decision about the need to wear a jacket or not. If one fails to fuzzify (for example, due to lack of familiarity with the Celsius temperature scale) then the decision process cannot continue or a possibly erroneous decision would be reached. So, you have been fuzzifying all along (without knowing it) whenever you made correct decisions.

A common fuzzification algorithm of a set $A = \{\mu_i/x_i | x_i \in x\}$ is performed by keeping μ_i constant and transforming x_i to a fuzzy set that depicts the expression about x_i , $K(x_i)$. The fuzzy set $K(x_i)$ is referred to as the kernel of fuzzification.

Fuzzified set A is expressed as

$$\sim A = \mu_1 K(x_1) + \mu_2 K(x_2) + \dots + \mu_n K(x_n)$$

where the symbol \sim means fuzzified.

3.9 Classical Reasoning

In classical binary logic, reasoning is based on two complementary mechanisms: deduction (modus ponens) and induction (modus tollens). Deduction is used to obtain conclusions by means of forward inference and induction is used to deduce causes by means of backward inference. The two mechanisms are contrasted in Table 3.2. In that table A and B are crisp sets and the symbol \rightarrow means implies.

Table 3.1: Deduction and Induction

	Deduction	Induction
Rule	IF x is $A \rightarrow y$ is B	IF x is $A \rightarrow y$ is B
Premise	X is A	Y is not B
Conclusion	Y is B	X is not A

In other words, given the rule: :IF x is A , THEN y is B and the observation that “ x is A ”, one concludes by deduction that : “ y is B ” . In a mathematical shorthand:

$$(p \wedge (p \rightarrow q)) \rightarrow q$$

Given the same rule but the observation that “ y is not B ”, one concludes by induction that: “ x is not A ”. In a mathematical shorthand:

$$(q \wedge (p \rightarrow q)) \rightarrow p$$

3.9.1 Composition of fuzzy relations

The composition of two crisp binary relations P and Q requires that the relations be compatible—i.e., $A \times B$ and $B \times C$ share the set B . The composition $R = P \circ Q$ consists of pairs (a,b) from $A \times C$ that are connected through at least one element in B . In fuzzy relations, the connections have degrees of strength stemming from the fact P and Q are fuzzy sets. There are several types of fuzzy relations compositions. The most common in engineering applications is the max-min composition. In this composition scheme the strength of the connection is determined by the smaller strength connection of the two in a chain that connects a to c . Among the chains that connect the two elements, the one with the largest strength is the one that is selected to characterize the relation.

In mathematical form, we can write

$$P \circ Q = \{ \max \min[\mu_P (a,b), \mu_Q (b,c)] / (a,c) \mid a \in A, b \in B, c \in C$$

3.10 Fuzzy Reasoning

Fuzzy reasoning is based on inference rules of the form

IF <premise>, THEN <consequence>

as is the case in classical logic, but fuzzy sets, rather than crisp sets, are used. Fuzzy sets define linguistic variables and hence fuzzy inference rules can model a system linguistically. Fuzzy algorithms are mathematically equivalent to fuzzy relations and fuzzy inference is equivalent to fuzzy composition.

There are numerous ways that have been put forward to express an inference rule.

A direct, simple inference rule takes the form:

IF x is A , THEN y is B

where A and B are fuzzy sets.

If the number of rules is large it becomes more convenient to employ a fuzzy relations approach. The IF/THEN rules are converted to fuzzy relations, then fuzzy composition is used to infer conclusions. The conversion from IF/THEN rules to fuzzy relations could be defined in more than one way. A simple method is given by:

$$R = A \rightarrow B = A \times B$$

An inference rule could have more than one proposition. For example, a rule of inference with two propositions would take the form: if x is A , and y is B , then z is C where A , B , and C are fuzzy subsets of X , Y , and Z , respectively.

The rule may be written as:

$$A \text{ and } B \rightarrow C$$

A fuzzy algorithm has several rules, such as

Rule 1: IF x is A_1 , THEN y is B_1

Rule 2: IF x is A_2 , THEN y is B_2

.

.

.

Rule n : IF x is A_n , THEN y is B_n

The rules can be also written as

$$A_1 \rightarrow B_1$$

$$A_2 \rightarrow B_2$$

.

.

.

$$A_n \rightarrow B_n$$

This n -rule system can be converted to n relations: R_1, R_2, \dots, R_n . These relations can be combined into one relation, R , using fuzzy intersection operations or fuzzy union operations depending on how the rules are perceived to be connected.

$$R = R_1 \cup R_2 \dots \cup R_n, \text{ or}$$

$$R = R_1 \cap R_2 \dots \cap R_n$$

The difference in the way the rules are perceived to be related would obviously lead to different results.

3.11 FUZZY LOGIC CONTROLLER

Fuzzy logic controller is used for automatic generation control in a two area system. Basic block diagram of fuzzy logic controller is as shown under.

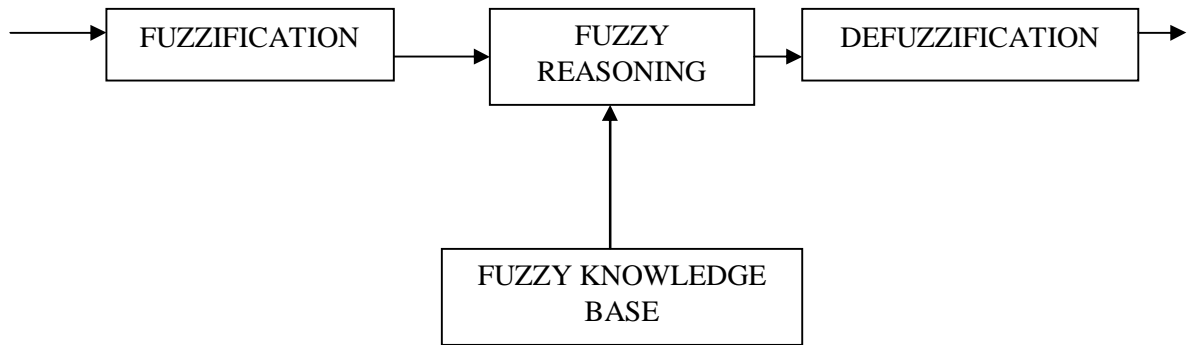

Figure 3.2 Basic structure of fuzzy logic controller.

The main building units of an FLC are a fuzzification unit, a fuzzy logic reasoning unit, a knowledge base, and a defuzzification unit. Defuzzification is the process of converting inferred fuzzy control actions into a crisp control action. [4]

13.11.1 Design

In the design of an FLC system it is assumed that:

- A solution exists.
- The input and output variables can be observed and measured.
- An adequate solution (not necessarily an optimum one) is acceptable.
- A linguistic model can be created based on the knowledge of a human expert.

Fuzzy modelling is the method of describing the characteristics of a system using fuzzy inference rules. The method has a distinguishing feature in that it can express linguistically complex nonlinear systems. It is however, very hard to identify the rules and tune the membership functions of the fuzzy reasoning. Fuzzy controllers are normally built with the use of fuzzy rules. These fuzzy rules are obtained either from domain experts or by observing the people *who are currently doing the control. The membership functions for the fuzzy sets will be derived from the information available from the domain experts and/or observed control actions. The building of

such rules and membership functions require tuning. That is, performance of the controller must be measured and the membership functions and rules adjusted based upon the performance. This process will be time consuming.

The basic configuration of Fuzzy Logic Controller (FLC) consists of four main parts

- (i) Fuzzification
- (ii) Knowledge base
- (iii) Decision-making logic and
- (iv) Defuzzification

The functions of the above modules are described below.

(i) The Fuzzification:

- (a) Measure the values of input variables
- (b) Performs a scale mapping that transforms the range of values of input variables into corresponding universe of discourse.
- (c) Performs the function of fuzzification that converts input into suitable linguistic values, which may be, **viewed** labels of fuzzy sets.

(ii) The Knowledge Base:

It consists of data base and linguistic control rule base.

- (a) The database provides necessary definitions, which are used to define linguistic control rules and fuzzy data, manipulation in an, FLC.
- (b) The rule base characterizes the control goals and control policy of the domain experts by means of set of linguistic control rules.

(iii) The Decision Making Logic:

It is the kernel of an FLC; it has the capability of simulating human decision making based on fuzzy concepts and of inferring fuzzy control actions employing fuzzy implication and the rules of inference in fuzzy logic.

(iv) The Defuzzification:

- (a) A scale mapping which converts the range of values of input variables into corresponding universe of discourse.
- (b) Defuzzification, which yields a non-fuzzy, control action from an inferred fuzzy control action.

4.1 Application of Fuzzy Logic to Automatic Generation Control

Fuzzy logic is used to calculate ACE (out) i.e. control signal in the form of area control error that will be provided to both the areas to generate according to change in total load to maintain the system frequency within permissible limits. Area control error and change in frequency of the system as input are used as inputs for FLC.

4.1.1 Algorithm for fuzzy logic application to AGC problem

The calculation of the control action in the fuzzy algorithm consists of following four steps.

1. Calculate area control error (ACE) and change of frequency (Δf).
2. Convert the error and change of frequency into fuzzy variables i.e. linguistic variables such as Positive Big (PB), Positive Medium (PM) etc., as given below.
3. Evaluate the decision rules shown in rule base given below using the compositional rule of inference.
4. Calculate the deterministic input required to regulate the process.

The control rules are formulated in linguistic terms using fuzzy sets to describe the magnitude of error, the frequency deviation and the magnitude of the appropriate control action.

NS = negative small

ZE = zero

PS = positive small

4.1.2.1 Rule base (with three membership functions)

$\Delta f/\text{ACE}$	PS	NS	ZE
PS	NS	ZE	PS
NS	PS	NS	ZE
ZE	ZE	PS	NS

Membership function used is the triangular.

Method used for defuzzification is centroid method.

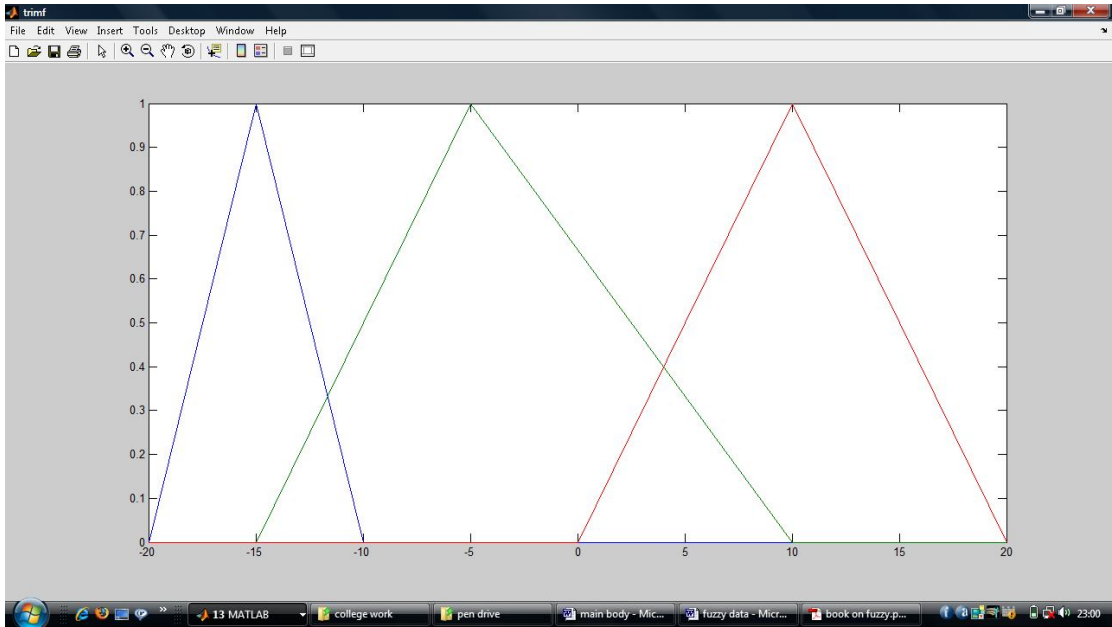

Figure 4.1 Sub sets defining ACE

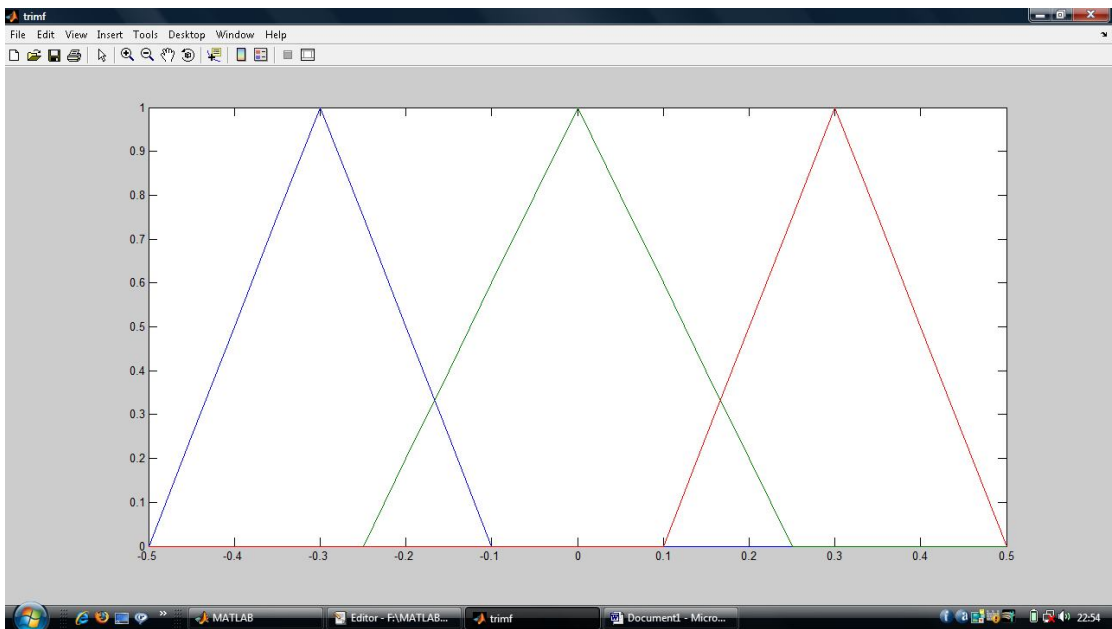

Figure 4.2 Subsets defining delF

4.1.2.1 Rule base (with 5 membership functions)

delF/ACE	NL	NS	ZE	PS	PL
NL	NL	NL	NS	NS	ZE
NS	NL	NL	NS	ZE	ZE
ZE	NS	NS	ZE	PS	PS
PS	ZE	PS	PS	PL	PL
PL	ZE	ZE	PS	PL	PL

Where

NL = negative large

NS = negative small

ZE = zero

PS = positive small

PL = positive large

4.2 RESULTS

Area Control Error measured = -10.99 MW

After applying fuzzy logic (using 3 membership functions) this value is reduced to -8 MW.

And applying fuzzy logic (using 5 membership functions this value is reduced to -7.5MW.

Table 4.2 Data set 1

	For area1	For area2
Regulation Hz/pu MW	2.4	2.4
Damping constant pu/MW Hz	0.00833	0.00833
Generation capacity	2000	2000
Frequency	50	50
Load change (MW)	100	0

Table 4.3 results with data set 1

	For area 1	For area 2
Bias factor	0.425	0.425
Frequency deviation	-0.100007	-5.000333
New frequency	44.9997	44.9997
Change in generation(MW)	49.019	49.019
Change in load (MW)	0.8331	0.8336
Area control error	-50.050	-50.04253
Net interchange power	-50	50

Table 4.4 Data set 2

	For area1	For area2
Regulation Hz/pu MW	0.01	0.02
Damping constant pu/MW Hz	0.8	1
Generation	500	500
Frequency	50	50
Load change (MW)	30	0

Table 4.5 Results with data set 2

	For area 1	For area 2
Frequency deviation(pu)	-0.00998	-0.00998
New frequency	49.960	49.960
Change in generation (MW)	19.76	9.88
Change in load (MW)	0.15	0.19
Area control error	-10.88	-10.99
Net interchange power	-10.07	-10.07

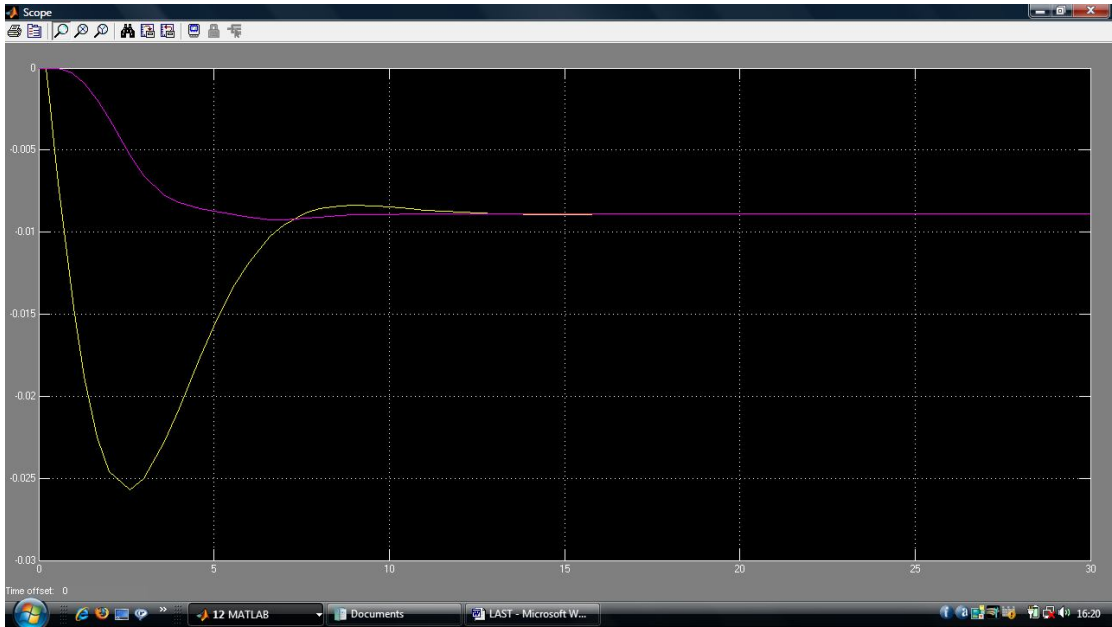

(yellow for ΔF_1 , pink for ΔF_2)

Figure 4.3 Frequency deviation step response for area 1 and area 2 with conventional controller

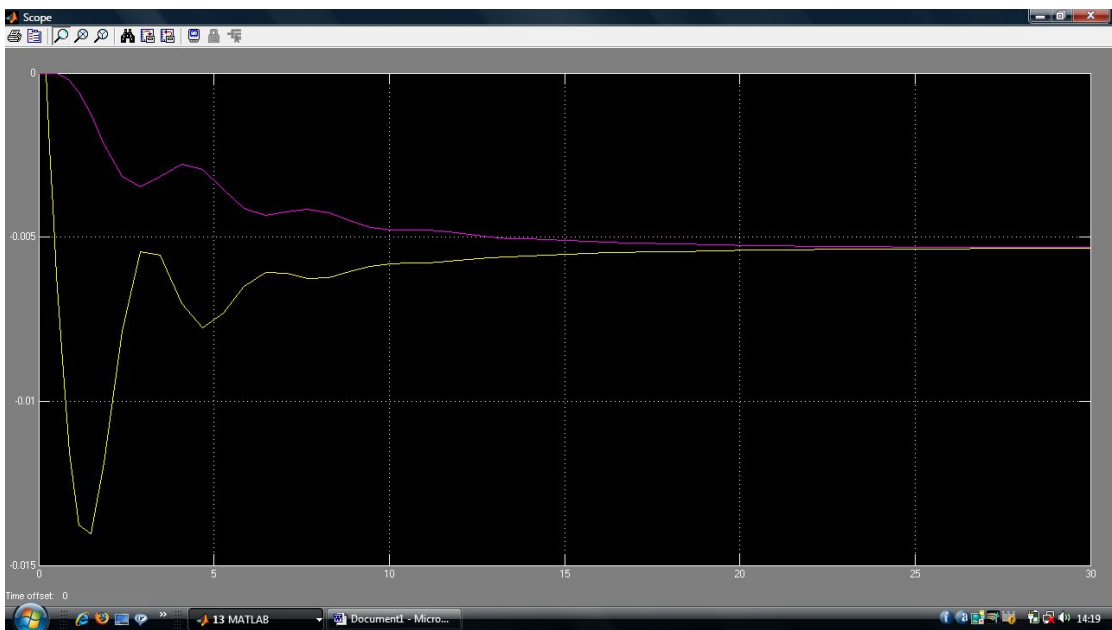

(yellow for ΔF_1 , pink for ΔF_2)

Figure 4.4 Frequency deviation step response for area 1 and area 2 using fuzzy logic controller

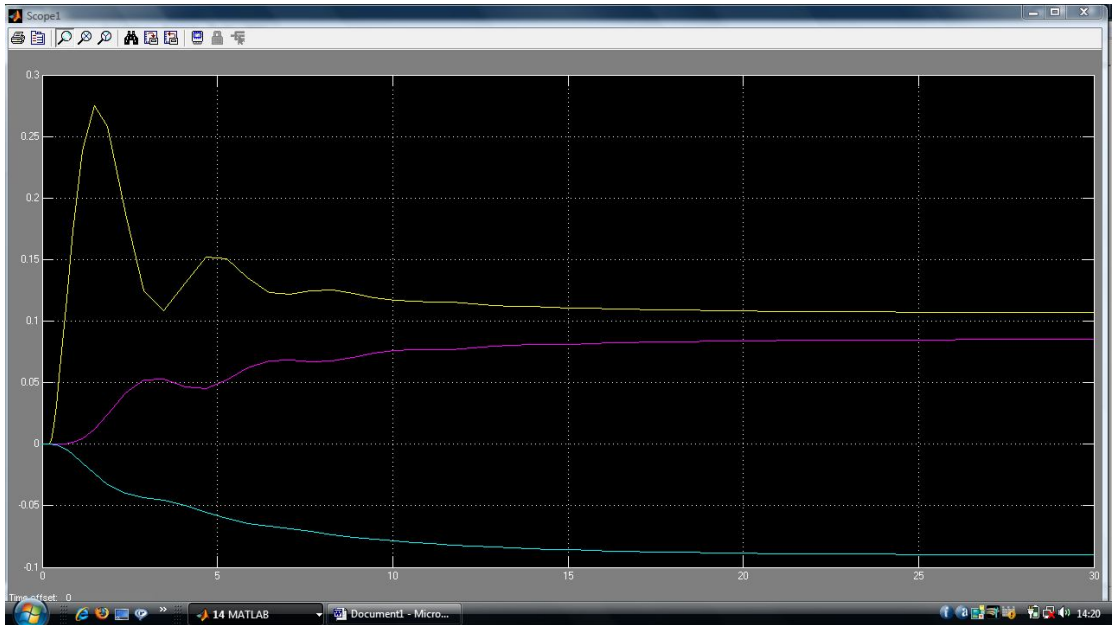

(yellow for P_{m1} , pink for P_{m2} , green for ΔP_{tie})

Figure 4.5 Power deviation step response for area 1 and 2, and ΔP_{tie} using conventional controller

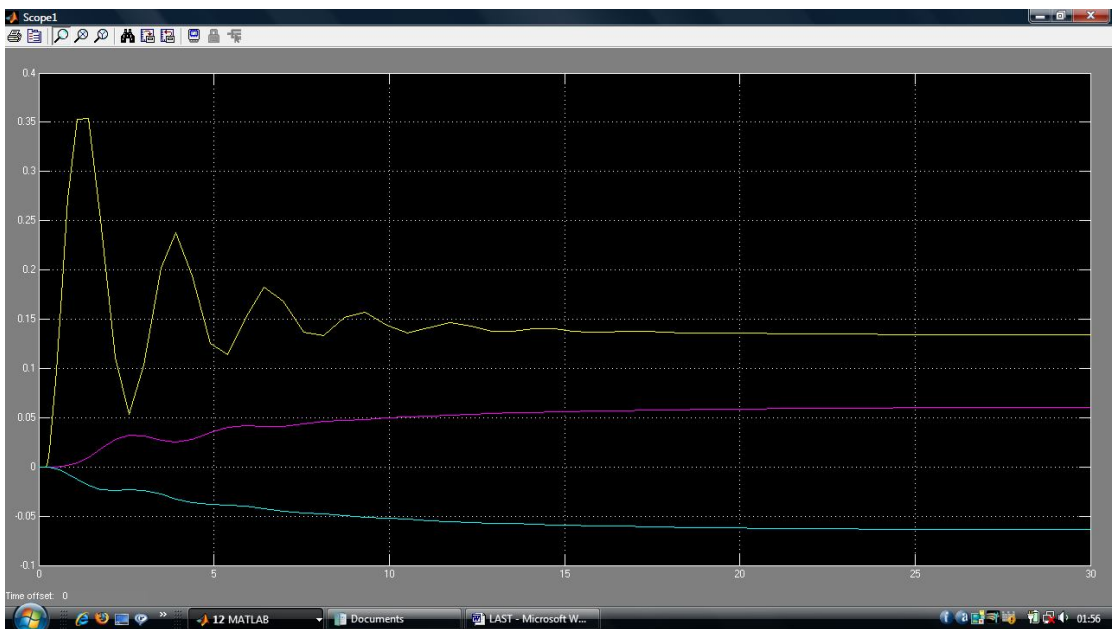

(yellow for P_{m1} , pink for P_{m2} , green for ΔP_{tie})

Figure 4.6 Power deviation step response for area 1 and 2, and ΔP_{tie} using fuzzy logic controller

CHAPTER 5

CONCLUSIONS

5.1 Summary of major findings

Performing the Automatic generation control of two interconnected areas change in frequency with load change in any of the two areas and how much generation change occurs in both the areas is calculated. How much power the two areas have to interchange to keep the frequency within permissible limits. Measured values are given in section 4.2 in chapter 4. And area control is measured -10.08 and it is reduced to -8 by applying fuzzy logic to AGC problem in a two area system.

And frequency response for step deviation in a two area system is better by using fuzzy logic controller in comparison to conventional controller.

5.2 Scope of the future work

The primary objectives of Automatic Generation Control are to regulate frequency to the specified nominal value and to maintain the interchange power between control areas at the scheduled values. In this work AGC for a two area system is carried out, the future scope of this work is that AGC can be carried out for more than two areas. As in this work Fuzzy Logic is used to reduce area control error is reduced to some extent but it can be reduced more by applying some other artificial intelligence technique also.

REFERENCES

- [1] A J Wood and B F Wollenberg. 'Power Generation, Operation and Control'. John Wiley & Sons, 1984.
- [2] A K Swain, Member, "A Simple Fuzzy Controller for Single Area Hydro Power System Considering Generation Rate Constraints" IE(I) Journal-EL, pp 12-17, May 17, 2005
- [3] A. Mangla and J. Nanda , "Automatic Generation Control of an Interconnected Hydro-Thermal System Using Conventional Integral and Fuzzy Logic Controller" international conferencr on electrical utility, deregulation, destructuring, and power technologies,pp372-377, April 2004.
- [4]Ahmad M. Ibrahim, Fuzzy Logic for Embedded Systems Applications, elsevier science (USA)-2004
- [5] Barjeev Tyagi and S. C. Srivastava "A Decentralized Automatic Generation Control Scheme for Competitive Electricity Markets". IEEE transactions on power systems, vol. 21, no. 1, pp 312-320, February 2006.
- [6]Bjorn H. Bakken and Ove S. Grande, Automatic Generation Control in a Deregulated Power System , IEEE Transactions on Power Systems, Vol. 13, No. 4, pp 1401 1406, November 1998.
- [7] D.M. Vinod Kumar, "Intelligent controllers for Automatic Generation Control". IEEE, pp 557-574, 1998.
- [8]Engin Yesil, Aysen Demiroren, Erkin Yesil "Automatic generation control with fuzzy logic controller in the power system including three areas"
- [9] G.A. Chown and R. C. Hartman, "Design and Experience with a Fuzzy Logic Controller for Automatic Generation Control (AGC)" pp352-357, 1997

- [10] G. L. Kusic, J.A. Sutterfield, A. R. Caprez, J. L. Haneline, B. R. Bergman “Automatic generation control for hydro systems.” IEEE Transactions on Energy Conversion, Vol. 3, No. 1, pp 33-39, March 1988
- [11] George Gross, Fellow, IEEE and Jeong Woo Lee “Analysis of Load Frequency Control Performance Assessment Criteria”. IEEE transactions on power systems, vol. 16, no. 3, pp 520-525 August 2001.
- [12] H.D. Mathur and H.V. Manjunath “Frequency stabilization using fuzzy logic based controller for multi-area power system”, The South Pacific Journal of Natural Science, pp22-30, April 2007.
- [13] I. Burhan Tiirkgen “Fuzzy logic : review of recent concerns” Department of Mechanical **and** Industrial Engineering, University of Toronto, Toronto, Ontario Canada.
- [14] Ignacio Egido, Fidel Fernandez-Bernal, Luis Rouco, Eloisa Porras, and Angel Saiz-Chicharro “Modeling of Thermal Generating Units for Automatic Generation Control Purposes”, IEEE TRANSACTIONS ON CONTROL SYSTEMS TECHNOLOGY, VOL. 12, NO. 1, pp205-210 JANUARY 2004
- [15] J. Nanda ; Manoranjan Parida; “Automatic Generation Control of a Hydro-Thermal System in Deregulated Environment” pp 942-947
- [16] Janardan Nanda, Ashish Mangla, and Sanjay Suri, “Some New Findings on Automatic Generation Control of an Interconnected Hydrothermal System With Conventional Controllers” IEEE Transactions on energy conversion, vol. 21,no. 1, pp 187-194, March 2006.
- [17] J. Nanda; M.Parida, A. Kalam “Automatic generation control of a multi-area power system with conventional integral controllers.”

- [18] Li Pingkang Beijing and Ma Yongzhen
 “Some New Concepts in Modern Automatic Generation Control Realization”.pp1232-1236, 1998
- [19] M.F. Hossain T. Takahashi M.G. Rabbani M.R.I. Sheikh T , M.S. Anower
 “Fuzzy-Proportional Integral Controller for an AGC in a Single Area Power System”
 4th International Conference on Electrical and Computer Engineering
 ICECE 2006, 120-123 December 2006.
- [20] M. G. Rabbani, M. F. Hossain, M. R. I. Sheikh and M. S. Anower “Application of fuzzy controlled SMES unit in Automatic Generation Control” 3rd ICECE 2004, 28-30 December 2004.
- [21] M.S. Anower M.G. Rabbani M.F. Hossain M. R. I. Sheikh M Rakibul Islam
 “Fuzzy frequency controller for an AGC for the improvement of power system dynamics”. 4th ICECE 2006,pp 5-8, 19-21 December 2006
- [22] Nouredine Bekhouche and Ali Feliachi “Decentralized estimation for the automatic generation control problem in power systems” pp632-621, 1992
- [23]N. Jaleeli, L. VanSlyck, D. Ewart, L.Fink and A. Hoffmann. "Understanding Automatic GenerationControl." IEEE Transactions on Power Systems, vol. 7, pp. 1106-1122, August 1992.
- [24] N. T. Nguyen and V. Kreinovich “Fuzzy Logic, Logic Programming, and Linear Logic: Towards a New Understanding of Common Sense”
- [25] P. Kundur, Power System Stability and Control. Palo Alto, CA: McGraw-Hill, 1994

APPENDIX – A

List of symbols used

1	used for denoting area1
2	used for denoting area2
R	speed regulation of governor
D	load damping constant
f	frequency of the system
M	inertia constant
T_G	governor response time
T_t	turbine time constant
K_i	integral gain
ΔP_D	incremental load change
Δf	change in frequency
ΔP_{12}	interchange power between area 1 and area 2
B	frequency bias coefficient

APPENDIX – B

Abbreviations used

AGC Automatic Generation Control

ACE Area Control Error

FLC Fuzzy Logic Controller

LFC Load Frequency Control