

CONTROL OF PHOTOVOLTAIC GRID CONNECTED SYSTEM USING INCREMENTAL CONDUCTANCE METHOD

Thesis submitted in partial fulfillment of the requirements for the award of degree of

Master of Engineering

In

Power Systems & Electric Drives



Thapar University, Patiala

By:

Menika Sharma

Regn. No. 801041030

Under the supervision of

Mr.Parag Nijhawan

Assistant Professor, EIED

&

Ms. Suman Bhullar

Assistant Professor, EIED

JULY 2012

ELECTRICAL & INSTRUMENTATION ENGINEERING DEPARTMENT

THAPAR UNIVERSITY

PATIALA – 147004

CERTIFICATE

I hereby certify that the work which is being presented in this thesis entitled, “ **Control of Photovoltaic Grid connected system using Incremental Conductance method**” in partial fulfillment of the requirements for the award of degree of Master of Engineering in *Power Systems & Electric Drives* submitted in Electrical and Instrumentation Engineering Department of Thapar University, Patiala, is an authentic record of my own work carried out under the supervision of Mr. Parag Nijhawan, Assistant Professor, EIED and Ms. Suman Bhullar, Assistant Professor, EIED and refers other researcher’s work which are duly listed in the reference section.

The matter embodied in this thesis has not been submitted for the award of any other degree to any other university.

Menika Sharma
11/7/12

(Menika Sharma)

Regn. No. 801041030

This is to certify that above statement made by the candidate is correct and true to best of my knowledge

Bhullar
11/7/2012
(Ms. Suman Bhullar)
Assistant Professor, EIED
Thapar University, Patiala

Parag
11/07/2012
(Mr. Parag Nijhawan)
Assistant Professor, EIED
Thapar University, Patiala

Countersigned by:

S. Ghosh
(Dr. Samarajit Ghosh)
Professor & Head
Electrical and Instrumentation Engg. Department
Thapar University, Patiala.

S.K. Mohapatra
(Dr. S.K. Mohapatra)
Dean (Academic Affairs)
Thapar University, Patiala

ACKNOWLEDGEMENT

First and foremost, I thank God, the Almighty for his strength and blessings to carry out this work.

I feel honored in expressing my profound sense of gratitude and sincere thanks to **Mr. Parag Nijhawan**, Assistant Professor, Electrical & Instrumentation Engineering Department, Thapar University, Patiala for his gracious efforts, patient guidance, keen pursuit and wise counsel which has remained as a valuable asset for the successful fulfillment of my thesis.

I am highly grateful to **Dr. Smarajit Ghosh**, Head, Electrical & Instrumentation Engineering Department, Thapar University, Patiala for providing this opportunity to carry out the present work

I also express my gratitude to **Ms. Suman Bhullar**, Assistant Professor, Electrical & Instrumentation Engineering Department, Thapar University, Patiala and other faculty members of the department for their intellectual support throughout the course of this work.

The paucity of words does not compromise for extending my thanks to all my family members for their love, inspiration, encouragement and support.

Finally, I am indebted to all whosoever have contributed to provide help to carry out the present work.

Menika Sharma

Regn.No. 801041030

ABSTRACT

The depletion of fossil fuel resources on a worldwide basis has necessitated an urgent search for alternative energy sources to meet up the present day demands. Solar energy is clean, inexhaustible and environment-friendly potential source among renewable energy options. Among the renewable energy sources, the energy thro' the photovoltaic effect can be considered the most essential and prerequisite sustainable resource because of the abundance and sustainability of solar radiant energy. Regardless of the intermittency of sunlight, solar energy is widely available and free of cost. There are so many ways to generate electricity from solar energy. Recently, PV array system is likely recognized and widely utilized to the forefront in electric power applications. It can generate direct current electricity without environmental impact and contamination when is exposed to solar radiation. Being a semiconductor device, PV system is static, quiet and free of moving parts, and these make it have little operation and maintenance costs. The objective of this work is to study the control of photovoltaic grid-connection and power quality managements.

TABLE OF CONTENTS

Certificate	i
Acknowledgement	ii
Abstract	iii
Table of Contents	v
List of Figures	vi
List of Tables	viii
Chapter 1	
INTRODUCTION WITH ENERGY	1-8
1.1 Overview	1
1.2 Renewable and non-renewable sources of energy	1
1.3 Energy and pollution	2
1.4 How to convert solar energy into electrical energy	2
1.5 Energy Scenario	3
1.6 Present Status of Development of Energy Resources	5
1.7 Literature survey	5
1.8 Scope of Work	7
1.9 Organization of thesis	8
Chapter2 PHOTOVOLTAIC SYSTEM	9-17
2.1 Definition of Photovoltaic	9
2.2 Working of Photovoltaic	9
2.3 Photovoltaic Cell	10
2.4 Photovoltaic Module	10
2.5 Photovoltaic Module Performance	11
2.5.1 Standard V-I characteristic curve of Photovoltaic Module	11
2.5.2 Effect of solar radiation on V-I characteristic curve of Photovoltaic Module	12
2.5.3 Effect of temperature on V-I characteristic curve of Photovoltaic Module	13
2.6 Photovoltaic Array	13
2.7 Types of Photovoltaic System	14
2.8 Grid Connected System	16
2.9 Proposed Grid Connected PV System	17

CHAPTER 3 MAXIMUM POWER POINT TRACKING (MPPT) TECHNIQUE	18-21
3.1 An overview of Maximum Power Point Tracking	18
3. 2Different MPPT techniques	19
3.2.1 Perturb & observe	19
3.2.2 Incremental conductance	20
3.2.3 Fractional open circuit voltage	20
3.2.4 Fractional short circuit current	20
3.2.5 Fuzzy logic control	20
3.2.6 Neural network	21
3.4 Characteristics of different MPPT technique	21
CHAPTER 4 SIMULATION AND RESULTS	22-26
4.1 Overview	22
4.2 Technique used (Incremental conductance method)	22
4.3 MATLAB Simulink model of PV array grid connected system using MPPT controller using Incremental Conductance technique	23
CHAPTER 5 CONCLUSION AND FUTURE WORK	27
5.1 Conclusion	27
5.2 Future work	27
REFERENCES	28-29

LIST OF FIGURES

Figure 1.1 Energy consumption by fuel in world by source, 2011	3
Figure 1.2 power generation capacities in India by source, 2011	4
Figure 2.1 working principle of a PV Cell	9
Figure 2.2 Photovoltaic Cell	10
Figure 2.3 Standard V-I characteristic curve of PV module	11
Figure 2.4 Change in PV module (V-I) on change in solar radiation	12
Figure 2.5 Typical current voltage curve for a module at standard temp.	13
Figure 2.6 PV cells are combined to create PV Modules which are linked to create PV Arrays	14
Figure 2.7 Grid Connected PV systems	15
Figure 2.8 Standalone PV systems	15
Figure 2.9 Hybrid System	16
Figure 4.1: Basic idea of Incremental Conductance method on a P-V curve of solar module	22
Figure 4.2: Simulation model PV Array grid connected system using (IC) MPPT	23
Figure 4.3: Subsystem of Voltage Source Current control	24
Figure 4.4: Subsystem of Boost converter control (MPPT)	24
Figure 4.5: Power waveform of the PV Array	24
Figure 4.6: Voltage waveform of the PV Array	25
Figure 4.7: Duty cycle waveform of the PV Array	25
Figure 4.8: Insolation waveform of the PV Array	25
Figure 4.9: Ref. voltage and Mean voltage of the PV Array	26
Figure 4.10: Voltage of Voltage source current control in the PV Array	26
Figure 4.11: Modulation Index of the PV Array	26

LIST OF TABLES

3.4: Characteristics of different MPPT techniques

21

1.1 Overview

Energy plays an important role in our daily life activities. As there is large increase in population, urbanization and industrialization. There is increase in energy demand too that is increasing day by day. The major fossil fuels like coal, petroleum and natural gas are depleting day by day. Moreover it is assumed that these fossil fuels will be depleted in few hundred years. The phenomenon of increasing the rate of energy consumption and supply is decreasing that result into energy shortage. This is referred to as energy crisis. So as to meet future energy requirement, any other alternative or renewable sources of energy have to be developed. All non conventional energy sources have geographical limitations except solar energy. Solar energy has less geographical limitations as compared to other non conventional sources of energy because solar energy is available over the entire globe. Nowadays solar energy has become one of the most promising renewable energy due to its inexhaustible and environmental advantages.

Solar energy is set to play an ever increasing role in generating the form, affecting the appearance and construction of buildings. The principal reason for this is that photovoltaic systems which produce electricity directly from solar radiation are becoming more widespread as their advantages become apparent and as costs fall [1].

1.2 Renewable and Non-Renewable Sources of Energy

The sources of energy that can be replenished (use again and again) in nature are known as renewable sources of energy. Renewable sources of energy are those energy sources which are not destroyed when their energy is utilized from them. Most renewable forms of energy, other than geothermal and tidal power, ultimately derive from solar energy. Renewable energy sources may be used directly, or used to create other more convenient forms of energy. Examples of direct use are solar ovens, geothermal heating, and water and windmills.

The sources of energy that cannot be replenished (cannot use again and again) in nature are known as non renewable sources of energy. However, we get most of our energy from non renewable energy sources, which include the fossil fuels – oil, natural gas and coal. They are called fossil fuels because they were formed over millions and millions of years by the action of heat from earth's core and pressure from rock and soil on the remains of dead plants

and animals. Examples of non-renewable sources of energy are fossil fuels like coal, petroleum etc.

1.3 ENERGY AND POLLUTION

The usage of conventional energy resources in industry leads to environmental damages by polluting the atmosphere. Few of examples of air pollution are Sulphur dioxide (SO₂), Nitrous oxide (NO_x) and Carbon oxides (CO, CO₂) emissions from boilers and furnaces, chloro-fluro carbons (CFC) emissions from refrigerants use, etc. In chemical and fertilizers industries, toxic gases are released. Cement plants and power plants spew out particulate matter and volatile organic compounds (VOCs). But most of the renewable energy is pollution free. So it will be better to go for renewable energies.

1.4 HOW TO CONVERT SOLAR ENERGY INTO ELECTRICAL ENERGY

There are two ways by which we can convert solar energy into electrical energy. These are:
Solar thermal: The solar collectors concentrate sunlight to heat a heat transfer fluid to a high temperature. The hot heat transfer fluid is then used to generate steam that drives the power conversion subsystem, producing electricity. Thermal energy storage provides heat for operation during periods without adequate sunshine.

Solar Photovoltaic: There is another way to generate electricity from solar energy is the use of photovoltaic cells; magic slivers of silicon that converts the solar energy falling on them directly into electricity. Large scale applications of photovoltaic for power generation either on the roofs of houses or in large fields connected to the utility grid are promising as well to provide clean, safe and sound alternatives to current methods of electricity generation.

1.4 ENERGY SCENARIO

Present scenario of non conventional source

1. The Indian economy uses a variety of energy sources both commercial and non-commercial. Fuel wood, animal waste and agricultural residue are the traditional or 'non-commercial' sources of energy that continue to meet the bulk of the rural energy requirements even today. However the share of these fuels in the primary energy supply has declined from over 70% in the early 50's to a little over 30% as of today. The traditional fuels are gradually getting replaced by the 'commercial fuels' such as coal, lignite, petroleum products, natural gas and electricity.

2. At the time of independence, the country had a poor infrastructure in terms of energy production and supply. The per capita consumption of energy was abysmally low and the access to energy was very inadequate for the common people. The economy was dependent largely on the non-commercial sources of energy for meeting the requirements of the households and human energy in case of agriculture and transport. During the years of independence, the demand for energy, particularly for commercial energy, registered a high rate of growth contributed largely by the changes in the demographic structure brought about through rapid urbanization, need for socio-economic development and the need for attaining and sustaining self reliance in different sectors of the economy. Over the years, the high rate of growth of energy demand could be sustained primarily through increased dependence on commercial energy sources such as coal, oil, natural gas and electricity.

1.5.1 Energy Scenario in India

By end of year 2011, capacity of power generation in India is about 152 GW. Even with such an Installed base, about 17% of the villages in India are non-electrified, which would translate to About 450 million. With a growing economy, the demand for power is growing at about 6% very year and the peak load demand is expected to reach 176 GW by

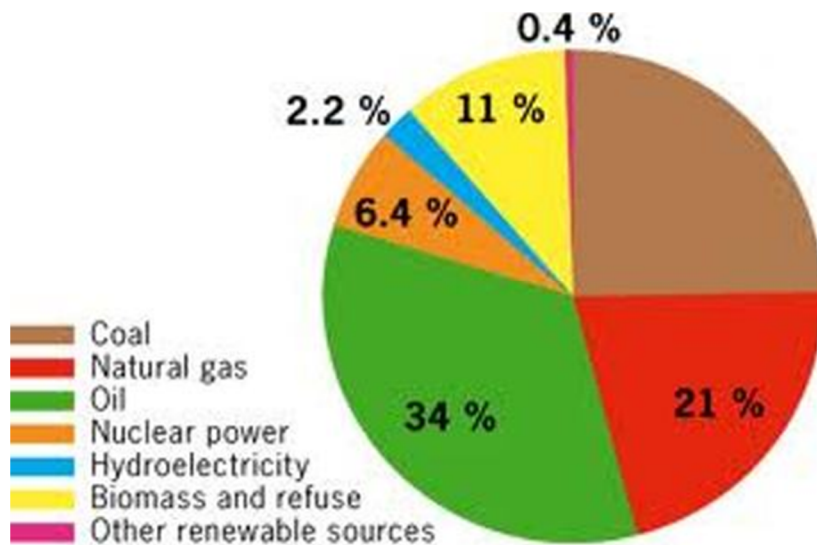

Figure1.1: Energy consumption by fuel in India by source 2011[triplehelixblog.com]

[13]

2012. The Indian power sector is highly dependent on coal as a fuel, with 53% of the total installed Capacity being coal based generation. Given the current scenario, coal consumption by the power sector is likely to reach levels of 173 Metric Tones by 2012. According to the Ministry of Coal, the existing coal reserves are estimated to last for another 40-45 years.

About 11% of the total power is sourced from oil & gas. Apart from automobiles and industry, the power sector is the largest importer of oil & gas in India. For 2008, the total oil imports Accounted for 7% of the GDP. India's per capita consumption of energy is far lower than that of the world average. Even with Such a low per capita consumption, during the year 2008-09, the power deficit is about 11% in Total demand and a deficit of more than 12% in peak load demand. This clearly signifies that the Available fuel is not sufficient to meet the rising demand for energy of India.

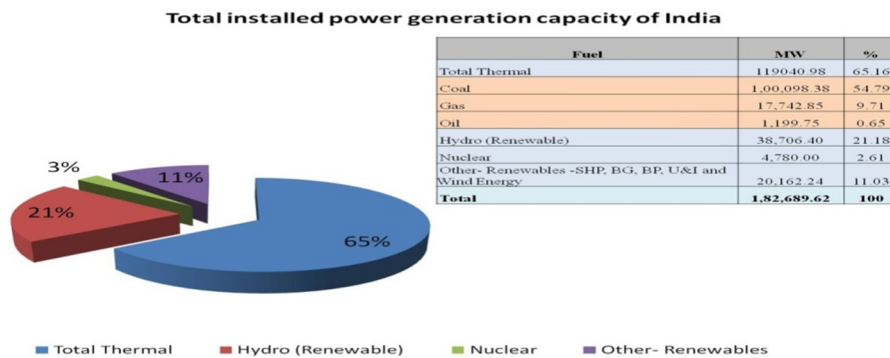

Figure 1.2: Power generation capacities in India by source, 2011[Greencleanguide.com]
[14]

1.5.2 ENERGY SCENARIO IN PUNJAB

The state of Punjab is the 1st state in the country which has allowed interstate sale of power generated from NRSE projects in accordance with open access regulations of the appropriate commission as per the addendum notified to the NRSE policy-2006.

Energy generation statistics in Punjab is:

- Total power sales by PSEB (Punjab state electricity board):41625MU's
- Total power generation:26897 MU's
- Net energy purchased:14728 MU's
- Energy purchase from NTPC: 7291 MU's
- NRSE generation: 231 MU's

The state at present is facing acute power shortages. The demand is increasing day by day. The state government has set up two new thermal power stations namely 1980MW Talwandi Sabo and 1320MW Rajpura in the private sector on BOO basis through tariff based competitive bidding as per guidelines of government of India. 540MW Goindwal sahib thermal power plant is also being setup by m/s GVK power limited on BOO basis. Punjab is far away from the coal mines/fuel sources. As the good quality of fuel is not available in

plenty and its cost is very high, so the existing thermal power plants are running with low quality of coal. That is why Punjab govt. also focusing of installing non-conventional and renewable energy plants. Mostly on biogas and solar. Good solar insolation level available at Punjab of 4-7Kwh/m²/day.

1.6 Present Status of Development of Energy Resources

Through the process of planned development undertaken over the last five decades, the country has taken major strides in stepping up the production of primary commercial energy. In the present scenario, renewable resources emerge as the best alternative. At present, renewable energy accounts for about 11% of India's installed generation capacity of 152GW. Concentrated efforts made in exploration and development of hydrocarbons has led to a significant step up in the production of oil and natural gas. India is blessed with an abundance of non-depleting and environmentally friendly renewable resources such as solar, wind, biomass, hydro, and cogeneration and geothermal. India has an abundance of solar radiation; PV is progressively becoming more attractive, than other renewable sources of power as its cost declines.

1.7 Literature survey

Studies show that a solar panel converts 30-40% of energy incident on it to electrical energy. A Maximum Power Point Tracking algorithm is necessary to increase the efficiency of the solar panel.

There are different techniques for MPPT such as Perturb and Observe (hill climbing method), Incremental conductance, Fractional Short Circuit Current, Fractional Open Circuit Voltage, Fuzzy Control, Neural Network Control etc. Among all the methods Perturb and observe (P&O) and Incremental conductance are most commonly used because of their simple implementation, lesser time to track the MPP and several other economic reasons. Several works are going on solar photovoltaic systems. Some of these are discussed below:

It is to provide an overview for those involved in building and building services design and for students of these disciplines. It is not intended to be exhaustive or definitive and it is necessary for users of the Guide to exercise their own professional judgment when deciding whether or not to abide by it [1].

Roger A. Messenger *et al.* [2] presents a comprehensive engineering basis for Photovoltaic design , so engineers can understand the what , why and how associated with the electrical,

mechanical, economic and aesthetic aspects of PV system design. This book educates about the analysis of the components used in PV systems.

F. Harashima *et al.* [3] is proposed to link a solar battery with a utility ac power line. The main control objectives are to optimize the power flow from the solar battery to the utility power line and to compensate the reactive power, including harmonic distortion.

B.K.Bose *et al.* [4] describes the control of a residential photovoltaic power conditioning system. The microcomputer is responsible for array current feedback control, maximum power tracking control, array safe zone steering control, phase-locked reference wave synthesis, sequencing control, and some diagnostics.

Z.Salameh *et al.* [5] presented a versatile, accurate Matlab/Simulink PV model suitable for use by power electronics specialists has been developed, and has been designed for easy implementation on Matlab/Simulink platform; conventional MPPT methods and MPPT methods suitable for partial shading conditions can be simulated by using this PV model.

Maliki Omar *et al.* [6] The PV array model accepts irradiance and temperature as variable parameters and outputs I-V and P-V characteristics. The Hill Climbing (HC) Algorithm is implemented to track the maximum power point (MPP).

Xiaogao Chen *et al.* [7] presented a paper about on “unified control of photovoltaic grid connection and power quality managements.” In this paper they present a control system that combines photovoltaic grid connected generation and power quality managements. The purpose of this paper is not only to realize photovoltaic generation, but also suppress current harmonics, compensate reactive power, eliminate voltage sags or swells and other power quality problems. To simplify the control, the synchronous reference frame method is applied in modeling the inverter. An adaptive predictive algorithm based P & Q control idea is employed and achieved good results in MPPT control of PV generation.

Theoretical analysis and MATLAB simulations show that the control structure of double loop has good dynamic performances and the proposed system can realize PV generation, harmonics suppression and reactive power compensation, as well as eliminating voltage sags or swells.

T. esram *et al.* [8] The many different techniques for maximum power point tracking of photovoltaic (PV) arrays are discussed. The techniques are taken from the literature dating back to the earliest methods. It is shown that at least 19 distinct methods have been introduced in the literature, with many variations on implementation. This paper should serve as a convenient reference for future work in PV power generation.

M.Lokanadham *et al.* [9] presented a paper on Incremental Conductance based maximum power point tracking (MPPT) for photovoltaic system. In recent years, a large number of techniques have been proposed for tracking the maximum power point (MPP). Maximum power point tracking (MPPT) is used in photovoltaic (PV) systems to maximize the photovoltaic array output power, irrespective of the temperature and radiation conditions and of the load electrical characteristics the PV array output power is used to directly control the dc-dc converter, thus reducing the complexity of the system. The method is based on use of a Incremental Conductance of the PV to determine an optimum operating current for the maximum output power.

J.A.Jiang *et al.* [10] presents the modeling of wind energy systems using MATLAB Simulink. The model considers the MPPT (Maximum Power Point Tracking) technique to track the maximum power that could be extracted from the wind energy, due the non-linear characteristic of the wind turbine.

H.Sugimoto *et al.* [11] presented that the derivative of output power with respect to output voltage of a photovoltaic array is equal to zero at the maximum power point. This kind of relationship is independent of insolation and temperature.

C.Hua *et al.* [12] presents the improved model of solar photovoltaic (SPV) module and back propagation neural network based maximum power point tracking (MPPT) for boost converter in a standalone photovoltaic system under variable temperature and insolation conditions.

1.8 Scope of work

This dissertation proposes the Matlab Simulink model of Photovoltaic (PV) Array grid connected system which is used for the improvement of power generation with the help of solar power. The major objectives are summarized as follows:

- Study the model of Photovoltaic Array Grid connected system.
- Investigating the performance of PV Array Grid connected system using MPPT controller with Incremental Conductance method.

- **1.9 Organization of thesis**

The work present in the thesis has been summarized in five chapters as per the details given below:

The Chapter 1 briefs the overview, literature view and scope of work. It also contains the organization of thesis.

The Chapter 2 describes the basic Photovoltaic terms like cell, module, and array. In this chapter PV module performance and types of Photovoltaic systems have been discussed.

The Chapter 3 includes the Maximum power point tracking (MPPT) technique. It also contains the different types of MPPT techniques used with solar Photovoltaic Technology.

Characteristics of different techniques have also been discussed.

The Chapter 4 discusses the MATLAB simulation model of Photovoltaic Array Grid connected system and the technique used which is Incremental Conductance method of MPPT. It also contains the results of the simulation model.

The Chapter 5 contains the conclusion and future scope

2.1 Definition of Photovoltaic

Photovoltaic (PV) are solid-state, semi-conductor type devices that produce electricity When exposed to light. The word photovoltaic's actually mean "electricity from light." Many hand-held calculators run off power from room light, which would be one example of this phenomenon. Larger power applications for this technology are also possible

2.2 Working of Photovoltaic

Photovoltaic are the direct conversion of light into electricity at the atomic level. Some Materials exhibit a property known as the photoelectric effect that causes them to absorb Photons of light and release electrons. When these free electrons are captured Electric current results that can be used as electricity. The photoelectric effect was first noted by a French physicist, Edmund Becquerel, in 1839, who found that certain Materials would produce small amounts of electric current when exposed to light. In 1905, Albert Einstein described the nature of light and the photoelectric effect on which Photovoltaic technology is based, for which he later won a Nobel Prize in physics. The First photovoltaic module was built by Bell Laboratories in 1954. It was billed as a solar Battery and was mostly just a curiosity as it was too expensive to gain widespread use. In The 1960s, the space industry began to make the first serious use of the technology to provide power aboard spacecraft. Through the space programs, the technology advanced, Its reliability was established, and the cost began to decline. During the energy crisis in The 1970s, photovoltaic technology gained recognition as a source of power for non-space Applications.

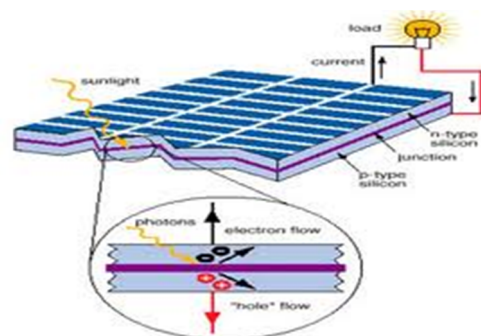

Figure 2.1: Working principle of a PV cell [polarpower.com] [15]

The diagram above illustrates the operation of a basic photovoltaic cell, also called a Solar cell. Solar cells are made of the same kinds of semiconductor materials, such as Silicon, used in the microelectronics industry. For solar cells, a thin semiconductor wafer is specially treated to form an electric field, positive on one side and negative on the other. When light energy strikes the solar cell, electrons are knocked loose from the Atoms in the semiconductor material. If electrical conductors are attached to the positive and negative sides, forming an electrical circuit, the electrons can be captured in the form of an electric current -- that is, electricity. This electricity can then be used to power a Load [2].

2.3 Photovoltaic cell

A photovoltaic cell or photoelectric cell is a semiconductor device that converts light to electrical energy by photovoltaic effect. If the energy of photon of light is greater than the band gap then the electron is emitted and the flow of electrons creates current. However a photovoltaic cell is different from a photodiode. In a photodiode light falls on n channel of the semiconductor junction and gets converted into current or voltage signal but a photovoltaic cell is always forward biased [2].

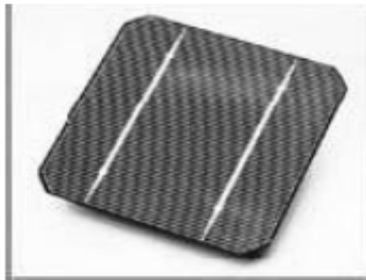

Figure 2.2: Photovoltaic Cell [homesolarpvpanels.com] [16]

2.4 Photovoltaic module

PV cells are the basic building blocks of PV modules. For almost all applications, the one half volt produced by a single cell is inadequate. Therefore cells are connected together in series to increase the voltage. Some of these series strings of cells may be connected in parallel to increase the current as well. Modules come in various standard sizes and can also be custom-made by the manufacturer. These modules comprise a series of interconnected PV cells, laminated between glass and a black sheet and held within a rigid aluminum frame. PV modules are usually the most cost effective solution and can be combined to form an array of the correct size for your building and electricity demand.

2.5 Photovoltaic module performance

To insure compatibility with storage batteries or loads, it is essential to know the electrical characteristics of photovoltaic modules. Here "I" is the abbreviation for current, expressed in amps. "V" is used for voltage in volts, and "R" is used for resistance in ohms.

2.5.1 Standard V-I characteristic curve of Photovoltaic Module

A photovoltaic module will produce its maximum current when there is essentially no resistance in the circuit. This would be a short circuit between its positive and negative terminals. This maximum current is called the short circuit current, abbreviated I_{sc} . When the module is shorted, the voltage in the circuit is zero.

Conversely, the maximum voltage is produced when there is a break in the circuit. This is called the open circuit voltage, abbreviated V_{oc} . Under this condition the resistance is infinitely high and there is no current, since the circuit is incomplete [2].

These two extremes in load resistance, and the whole range of conditions in between them, are depicted on a graph called an I-V (current-voltage) curve. Current, expressed in amps, is on the vertical Y-axis. Voltage, in volts, is on the horizontal X-axis as in Figure.

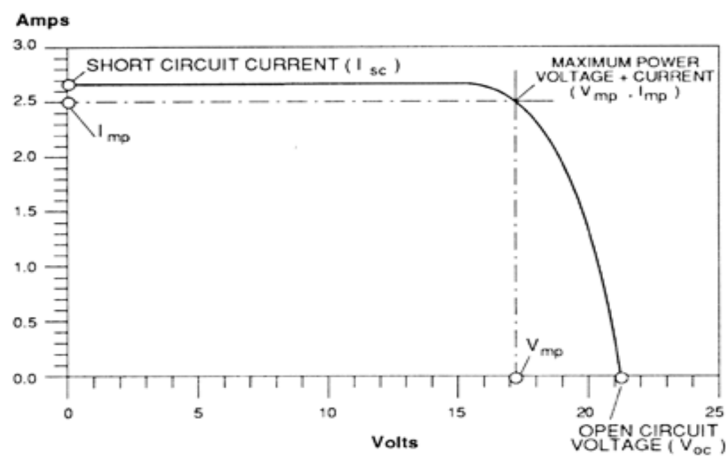

Figure 2.3: Standard V-I characteristic curve of Photovoltaic Module

[polarpower.com] [17]

As in the above Figure, the short circuit current occurs on a point on the curve where the voltage is zero. The open circuit voltage occurs where the current is zero. The power available from a photovoltaic module at any point along the curve is expressed in watts. Watts are calculated by multiplying the voltage times the current (watts = volts \times amps, or $W = VA$).

At the short circuit current point, the power output is zero, since the voltage is zero.

At the open circuit voltage point, the power output is also zero, but this time it is because the current is zero.

There is a point on the "knee" of the curve where the maximum power output is located. This point on our example curve is where the voltage is 17 volts, and the current is 2.5 amps. Therefore the maximum power in watts is 17 volts times 2.5 amps, equaling 42.5 watts.

The power, expressed in watts, at the maximum power point is described as peak, maximum, or ideal, among other terms. Maximum power is generally abbreviated as "I (mp)." Various manufacturers call it maximum output power, output, peak power, rated power, or other terms. The current-voltage (I-V) curve is based on the module being under standard conditions of sunlight and module temperature. It assumes there is no shading on the module.

2.5.2 Effect of solar radiation on V-I characteristic curve of Photovoltaic Module

Standard sunlight conditions on a clear day are assumed to be 1000 watts of solar energy per square meter (1000 W/m²). This is sometimes called "one sun," or a "peak sun." Less than one sun will reduce the current output of the module by a proportional amount. For example, if only one-half sun (500 W/m²) is available, the amount of output current is roughly cut in half.

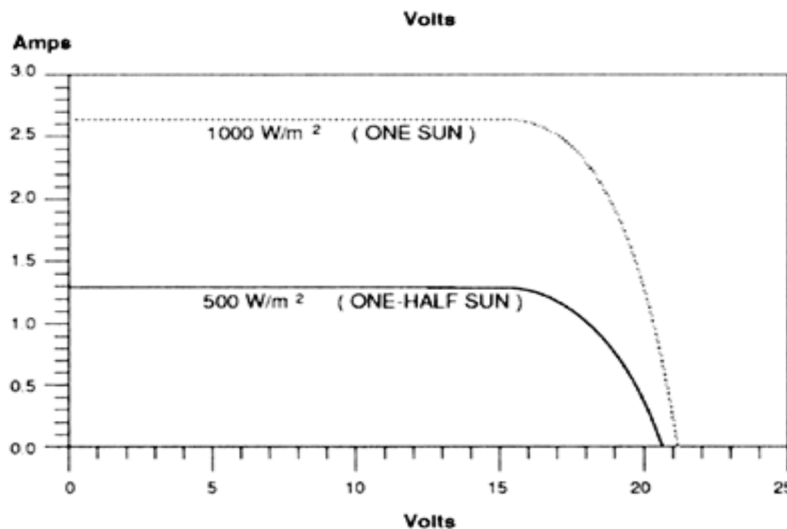

Figure 2.4: Change in Photovoltaic module voltage and current on change in solar radiation [polarpower.com] [18]

For maximum output, the face of the photovoltaic modules should be pointed as straight toward the sun as possible.

2.5.3 Effect of temperature on V-I characteristic curve of Photovoltaic Module

Module temperature affects the output voltage inversely. Higher module temperatures will reduce the voltage by 0.04 to 0.1 volts for every one Celsius degree rise in temperature (0.04V/0C to 0.1V/0C). In Fahrenheit degrees, the voltage loss is from 0.022 to 0.056 volts per degree of temperature rise.

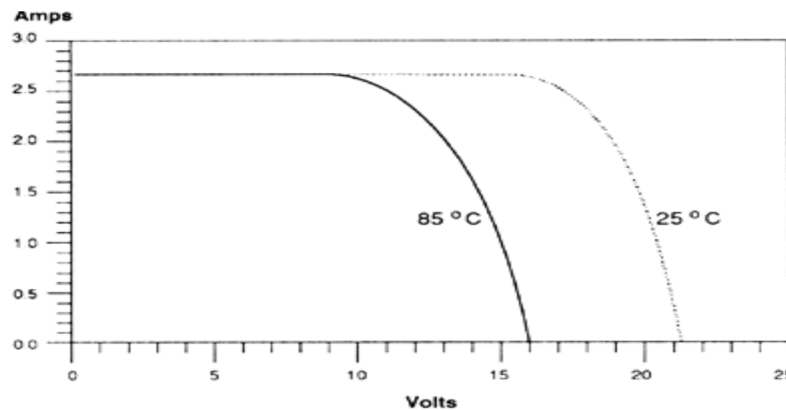

Figure 2.5: A Typical Current-Voltage Curve for a Module at 25°C and 85°C
[polarpower.com] [19]

This is why modules should not be installed flush against a surface. Air should be allowed to circulate behind the back of each module so its temperature does not rise and reducing its output. An air space of 4-6 inches is usually required to provide proper ventilation.

2.6 Photovoltaic Array

When modules are fixed together in a single mount they are called a panel and when two or more panels are used together, they are called an array. Single panels are also called arrays. When circuits are wired in series, the voltage of each panel is added together but the amperage remains the same. When circuits are wired in parallel the voltage of each panel remains the same and the amperage of each panel is added. This wiring principle is used to build photovoltaic (PV) modules. Photovoltaic modules can then be wired together to create PV arrays.

Solar array represents the fundamental power conversion unit of a photovoltaic system. Crystalline silicon cell technology is well established. The modules have a long lifetime (20 years or more) and their best production efficiency is approaching 18%. Solar energy can be utilized in two ways: solar heating cooling and solar electricity. Some appliances can be connected directly because they work on dc at the system voltage. Other appliances may need a voltage adaptor to adjust the voltage [3] or a power inverter to increase the voltage and change it to the ac forms. The application of solar arrays for residential or storage systems have been addressed in [4]. Solar arrays were developed for

power satellites in the space program [5]. PV array is a semiconductor device that generates DC electricity out of sunlight. It is a combination of PV modules connected in series and parallel. Energy produced by the PV array depends on some parameters such as temperature and solar irradiance [6].

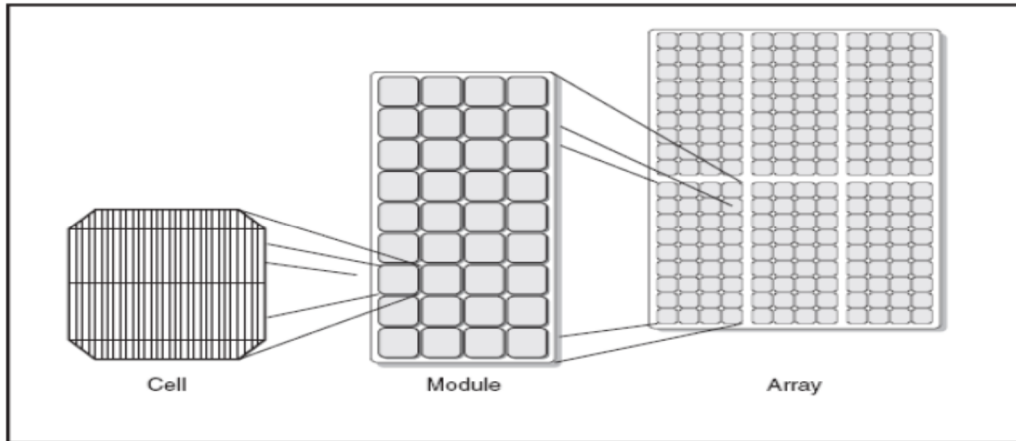

Fig2.6: PV cells are combined to create PV modules, which are linked to create PV array [digtheheat.com] [20]

2.7 Types of Photovoltaic systems

PV technology was 1st applied in space, by providing electricity to satellites. On the basis working operation PV systems operate in four basic forms.

- **Grid connected PV systems-** These systems are connected to broader electricity network. The PV system is connected to the utility grid using a high quality inverter, which converts DC power from the solar array into AC power that conforms to the grid's electrical requirements. During the day, the solar electricity generated by the system is either used immediately or sold off to electricity supply companies. In the evening , when the system is unable to supply immediate power , electricity can be bought back from the network.

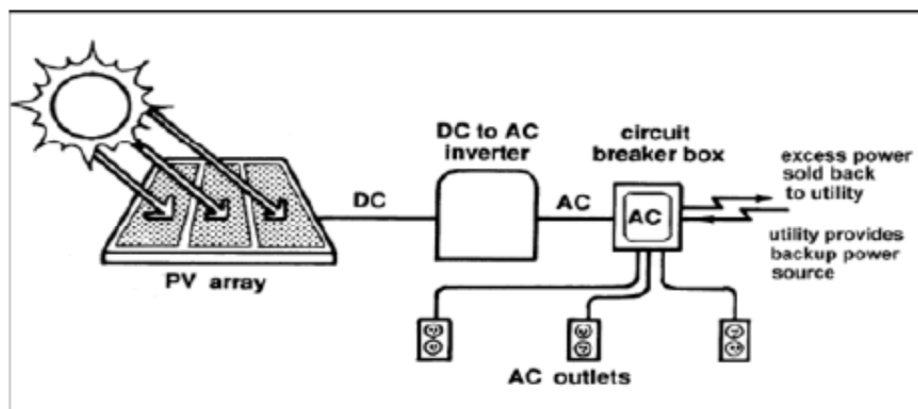

Figure 2.7: Grid connected PV systems [homesolarpvpanels.com] [21]

- Standalone systems-** PV systems not connected to the electric utility grid are known as off grid PV systems and also called 'stand-alone systems'. Direct systems use the PV power immediately as it is produced, while battery storage systems can store energy to be used at a later time, either at night or during cloudy weather. These systems are used in isolation of electricity grids, and may be used to power radio repeater stations, telephone booths and street lighting. PV systems also provide invaluable and affordable electricity in developing countries like India, where conventional electricity grids are unreliable or non-existent.

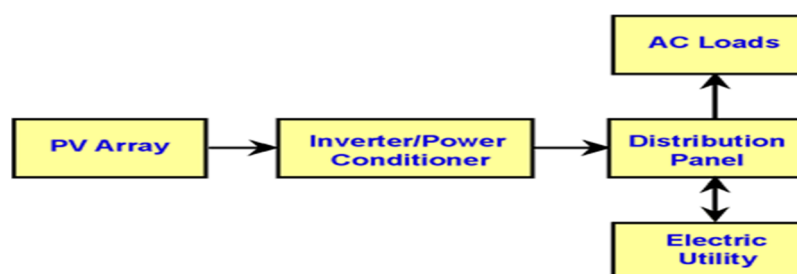

Figure 2.8: Stand-alone PV systems [homesolarpvpanels.com] [22]

Hybrid system

A hybrid system combines PV with other forms of power generation usually a diesel generator. Biogas is also used. The other form of power generation is usually a type which is able to modulate power output as a function of demand. However more than one form of renewable energy may be used like wind and solar. The photovoltaic power generation serves to reduce the consumption of non renewable fuel.

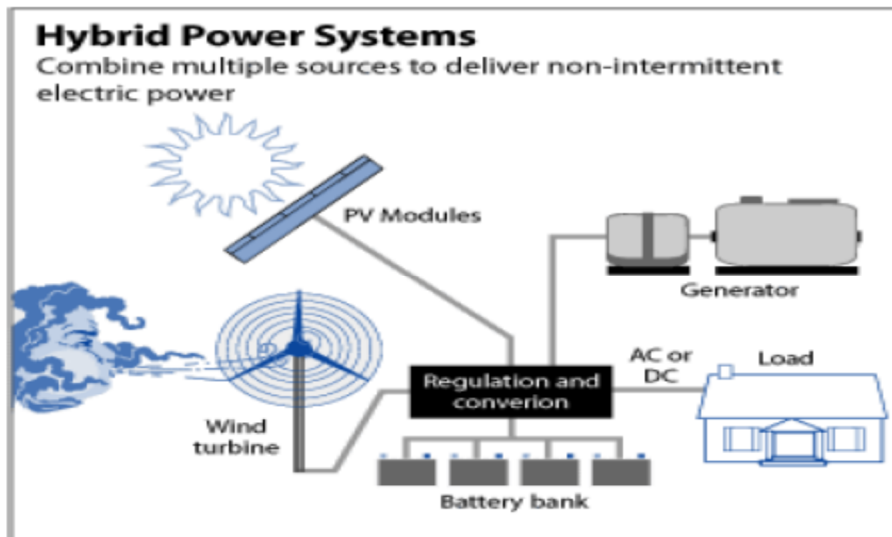

Figure 2.9: Hybrid system [en.wikipedia.org] [23]

Grid tied with battery backup PV system

Solar energy stored in batteries can be used at night time. By the use of net metering, unused solar power can be sold back to the grid. With this type of system, we can have power even if our neighborhood has lost the power.

2.8 Grid connected PV system

As day by day the demand of electricity is increasing and that much demand pollution also. Grid tied PV system is more reliable than other PV system. In this type of system, battery is not used, so capital cost reduces and therefore we use grid connected topology. If generated solar energy is integrated to the conventional grid, it can supply the demand from morning to afternoon that is the particular time range when the SPV system can fed to grid. Grid interconnection of photovoltaic power generation system has the advantage of more effective utilization of generated power. Grid interconnection of PV systems is accomplished through the inverter, which convert DC power generated from PV modules to AC power used for ordinary power supply for electrical equipments.

Inverter technology is very important to have reliable and safety grid interconnection operation of PV system. The proposed structure of PV grid connected system cannot only realize photovoltaic generation, but also suppress current harmonics, compensate reactive power, eliminate voltage sags or swells and other power quality problems.

An adaptive predictive maximum power point tracking (MPPT) algorithm is employed to improve the efficiency of PV generation. To simplify the control, the synchronous frame method is applied in modeling the inverter. The structure of a faster internal current control

loop and a slower external voltage control loop is used in order to obtain a good dynamic response.

Grid connected PV generation is one of the major development trends of photovoltaic applications. Meanwhile with the development of the power electronics industrialization process, a large no. of nonlinear loads has appeared. Harmonics and reactive current from nonlinear load induce that the power quality problems become more and more serious. PV grid connected generation operates during the day and has to stop at night. This affects the stabilization of power system and the utilization of equipment. Therefore in order to increase the utilization, the PV system can be designed to also provide the function of power quality managements [7].

This paper combines PV grid-connected generation device and shunt active power filter. The unified system can supply active power as well as current harmonics and reactive power compensation when sunshine is available.

2.9 The proposed grid-connected PV system

The unified system is composed of PV generation and energy storage system and the power quality comprehensive compensator. Solar energy is converted into electricity through PV array. Then the voltage across PV array is amplified with a unidirectional dc/dc boost converter so as to track the maximum power point of PV array conveniently [7]. After that, the dc/ac inverter converts dc power into ac power which is injected into the utility grid or directly supplies to local loads. At the same time the system can provide a strongly voltage compensation when the grid voltage sags or swells because it is equipped with large capacity storage devices. PV array also enhances the ability of its power compensation. When the grid voltage rises suddenly, the batteries are charged quickly, absorbing energy from the grid, thereby the grid voltage swells is restrained. In the same way, when the grid voltage drops suddenly, the batteries release energy quickly to grid, suppressing the voltage sags. Compared to the conventional photovoltaic generation devices, it can not only inject active power into grid, also has the Functions of reactive power compensation and harmonic suppression, eliminating grid voltage sags and swells. In addition, the system can act as shunt active power filter and UPS in the absence of sunshine or the weak sunshine [7].

3.1 An overview of Maximum Power Point Tracking

Maximum Power Point Tracking, frequently referred to as MPPT, is an electronic system that operates the Photovoltaic (PV) modules in a manner that allows the modules to produce all the power they are capable of. MPPT is not a mechanical tracking system that “physically moves” the modules to make them point more directly at the sun. MPPT is a fully electronic system that varies the electrical operating point of the modules so that the modules are able to deliver Maximum available power. Additional power harvested from the modules is then made available as increased battery charge current. MPPT can be used in conjunction with a mechanical tracking system, but the two systems are completely different.

A typical solar panel converts only 30 to 40 percent of the incident solar irradiation into electrical energy. Maximum power point tracking technique is used to improve the efficiency of the solar panel. According to Maximum Power Transfer theorem, the power output of a circuit is maximum when the Thevenin impedance of the circuit (source impedance) matches with the load impedance. Hence our problem of tracking the maximum power point reduces to an impedance matching problem [8].

In the source side we are using a boost convertor connected to a solar panel in order to enhance the output voltage so that it can be used for different applications like motor load. By changing the duty cycle of the boost converter appropriately we can match the source impedance with that of the load impedance.

Studies show that a solar panel converts 30-40% of energy incident on it to electrical energy. A Maximum Power Point Tracking algorithm is necessary to increase the efficiency of the solar panel. There are different techniques for MPPT such as Perturb and Observe (hill climbing method), Incremental conductance, Fractional Short Circuit Current, Fractional Open Circuit Voltage, Fuzzy Control, Neural Network Control etc. Among all the methods Perturb and observe (P&O) and Incremental conductance are most commonly used because of their simple implementation, lesser time to track the MPP and several other economic reasons [8].

3.2 Different MPPT techniques

There are various techniques used to track the maximum power point. Few of the most popular techniques are:

- 1) Perturb and observe (hill climbing method)
- 2) Incremental Conductance method
- 3) Fractional short circuit current
- 4) Fractional open circuit voltage
- 5) Neural networks
- 6) Fuzzy logic

The choice of the algorithm depends on the time complexity the algorithm takes to track the MPP, implementation cost and the ease of implementation.

3.2.1 Perturb & Observe

Perturb & Observe (P&O) is the simplest method. In this we use only one sensor, that is the voltage sensor, to sense the PV array voltage and so the cost of implementation is less and hence easy to implement. The time complexity of this algorithm is very less but on reaching very close to the MPP it doesn't stop at the MPP and keeps on perturbing on both the directions. When this happens the algorithm has reached very close to the MPP and we can set an appropriate error limit or can use a wait function which ends up increasing the time complexity of the algorithm.

However the method does not take account of the rapid change of irradiation level (due to which MPPT changes) and considers it as a change in MPP due to perturbation and ends up calculating the wrong MPP. To avoid this problem we can use incremental conductance method [9].

3.2.2 Incremental Conductance

Incremental conductance method uses two voltage and current sensors to sense the output voltage and current of the PV array.

At MPP the slope of the PV curve is 0.

$$(dP/dV)_{MPP}=d(VI)/dV$$

$$0=I+VdI/dV_{MPP}$$

$$dI/dV_{MPP} = - I/V$$

The left hand side is the instantaneous conductance of the solar panel. When this instantaneous conductance equals the conductance of the solar then MPP is reached. Here we

are sensing both the voltage and current simultaneously. Hence the error due to change in irradiance is eliminated. However the complexity and the cost of implementation increase [9].

As we go down the list of algorithms the complexity and the cost of implementation goes on increasing which may be suitable for a highly complicated system. This is the reason that Perturb and Observe and Incremental Conductance method are the most widely used algorithms.

3.2.3 Fractional open circuit voltage

The near linear relationship between V_{MPP} and V_{OC} of the PV array, under varying irradiance and temperature levels, has given rise to the fractional V_{OC} method.

$$V_{MPP} = k_1 V_{oc}$$

where k_1 is a constant of proportionality. Since k_1 is dependent on the characteristics of the PV array being used, it usually has to be computed beforehand by empirically determining V_{MPP} and V_{OC} for the specific PV array at different irradiance and temperature levels. The factor k_1 has been reported to be between 0.71 and 0.78. Once k_1 is known, V_{MPP} can be computed with V_{OC} measured periodically by momentarily shutting down the power converter. However, this incurs some disadvantages, including temporary loss of power. [9]

3.2.4 Fractional short circuit current

Fractional I_{SC} results from the fact that, under varying atmospheric conditions, I_{MPP} is approximately linearly related to the I_{SC} of the PV array.

$$I_{MPP} = k_2 I_{sc}$$

Where K_2 is proportionality constant. Just like in the fractional VOC technique, k_2 has to be determined according to the PV array in use. The constant k_2 is generally found to be between 0.78 and 0.92. Measuring ISC during operation is problematic. An additional switch usually has to be added to the power converter to periodically short the PV array so that I_{SC} can be measured using a current sensor[9].

3.2.5 Fuzzy Logic Control

Microcontrollers have made using fuzzy logic control popular for MPPT over last decade. Fuzzy logic controllers have the advantages of working with imprecise inputs, not needing an accurate mathematical model, and handling nonlinearity [9].

3.2.6 Neural network

Another technique of implementing MPPT which are also well adapted for microcontrollers is neural networks. Neural networks commonly have three layers: input, hidden, and output layers. The number of nodes in each layer vary and are user-dependent. The input variables can be PV array parameters like V_{OC} and I_{SC} , atmospheric data like irradiance and temperature, or any combination of these. The output is usually one or several reference signals like a duty cycle signal used to drive the power converter to operate at or close to the MPP [9]

This is the brief description of various techniques of MPPT. Basically the main technique which I have studied and worked over is the Incremental Conductance technique which is explained in the coming chapter.

3.3 Characteristics of different MPPT techniques [10]

MPPT Technique	Convergence speed	Implementation complexity	Periodic tuning	Sensed parameters
Perturb Observe	Varies	Low	No	Voltage
Incremental conductance	Varies	Medium	No	Voltage , Current
Fractional V_{OC}	Medium	Low	Yes	Voltage
Fractional I_{SC}	Medium	Medium	Yes	Current
Fuzzy logic control	Fast	High	Yes	Varies
Neural network	Fast	High	Yes	Varies

4.1 Overview

In this whole work PV array and MPPT technique plays a very important role.

Mainly the study of interconnected grid system is carried out with the help of PV array and MPPT (Maximum Power Point Tracking) technique of type Incremental Conductance method.

Several approaches have been proposed for tracking the MPP [11-12]. Incremental conductance (INC) method is widely used due to the ease of implementation, although they have some problems such as the oscillation about MPP and confusion by rapidly changing atmospheric conditions

4.2 Technique used

Incremental Conductance

In incremental conductance method the array terminal voltage is always adjusted according to the MPP voltage it is based on the incremental and instantaneous conductance of the PV module.

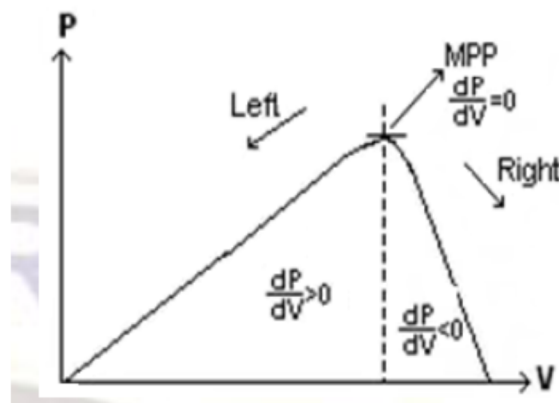

Figure 4.1: Basic idea of Incremental Conductance method on a P-V curve of solar module

Fig4.1 shows that the slope of the PV array power curve is zero at the MPP, increasing on the left of the MPP and decreasing on the right side of the MPP. The basic equations of this method are as follows:

$$\frac{dI}{dV} = -\frac{I}{V} \quad \text{At MPP}$$

$$\frac{dI}{dV} < -\frac{I}{V} \quad \text{Left of MPP}$$

$$\frac{dI}{dV} > -\frac{I}{V} \quad \text{Right of MPP}$$

Where I and V are P-V array output current and voltage respectively. The left hand side of equations represents incremental conductance of P-V module and the right hand side represents the instantaneous conductance. When the ratio of change in output conductance is equal to the negative output conductance, the solar array will operate at maximum power point.

4.3 MATLAB Simulink Model of PV Array Grid Connected System Using MPPT Controller Using Incremental Conductance Technique

The simulink model shown is the arrangement of PV array grid connected system which is connected with the voltage source current control by using MPPT technique of type Incremental Conductance method. MPPT is a fully electronic system that varies the electrical operating point of the modules so that the modules are able to deliver maximum available power.

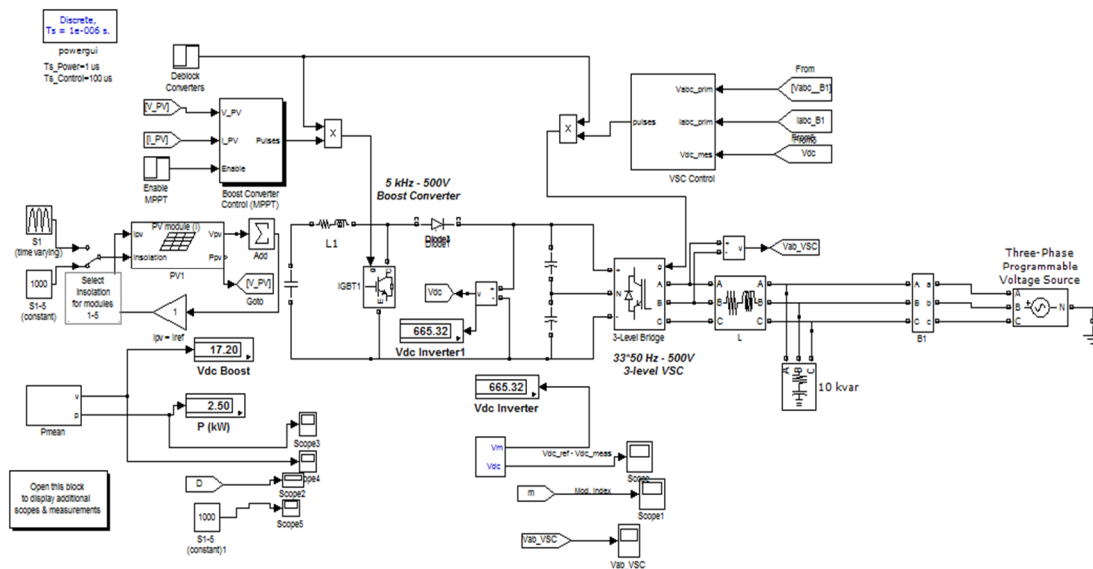

Figure 4.2: PV array Grid Connected system using (IC) MPPT

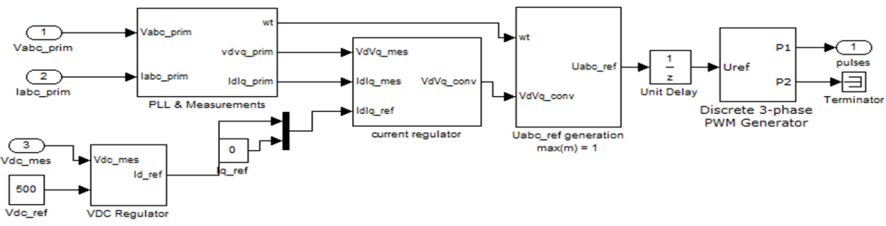

Figure 4.3: Subsystem of Voltage Source Current control

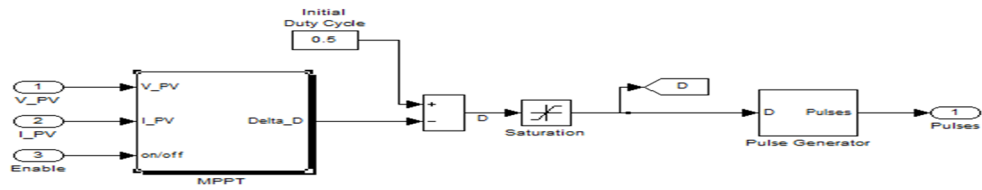

Figure 4.4: Subsystem of Boost Converter control (MPPT)

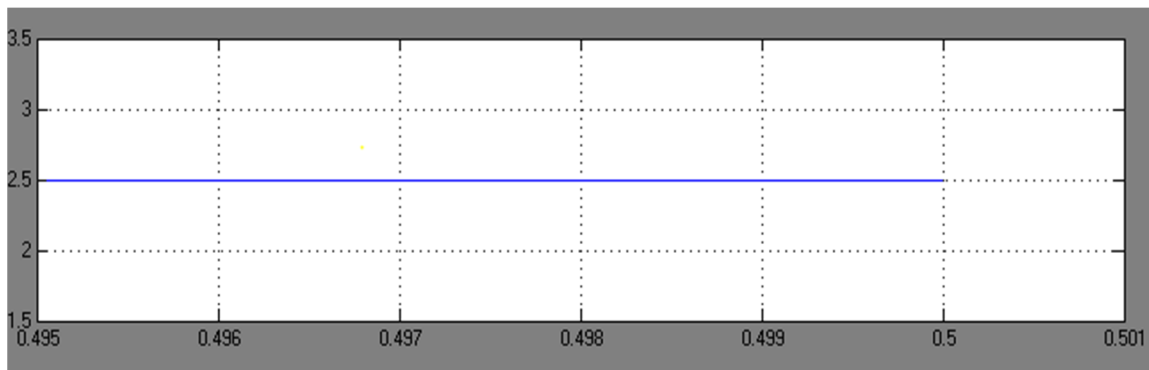

Figure 4.5: Power waveform of the PV Array

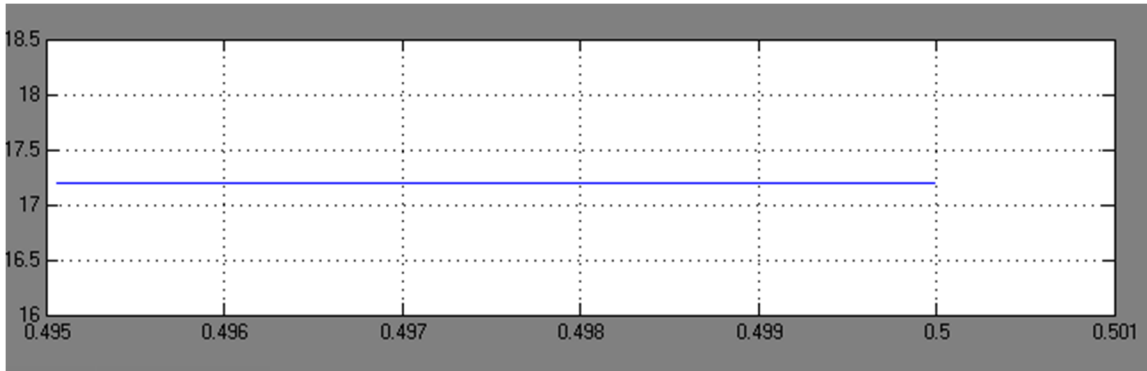

Figure 4.6: voltage waveform of the PV Array

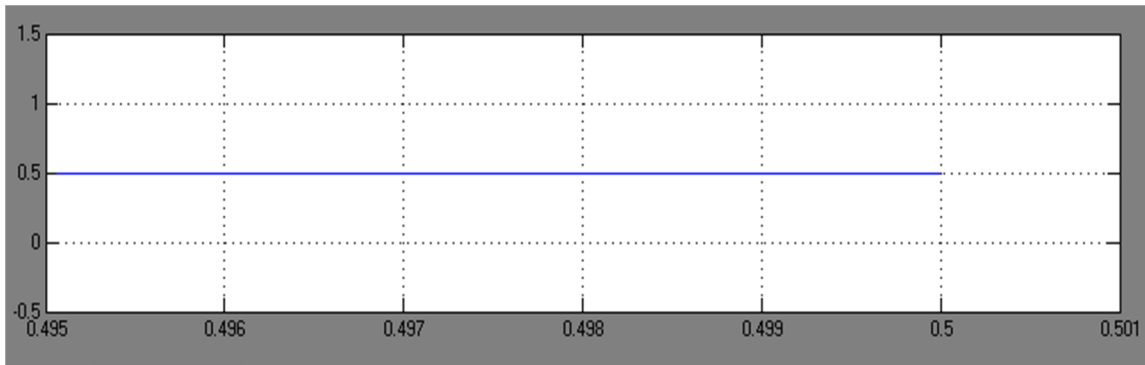

Figure4.7: Duty cycle of PV Array

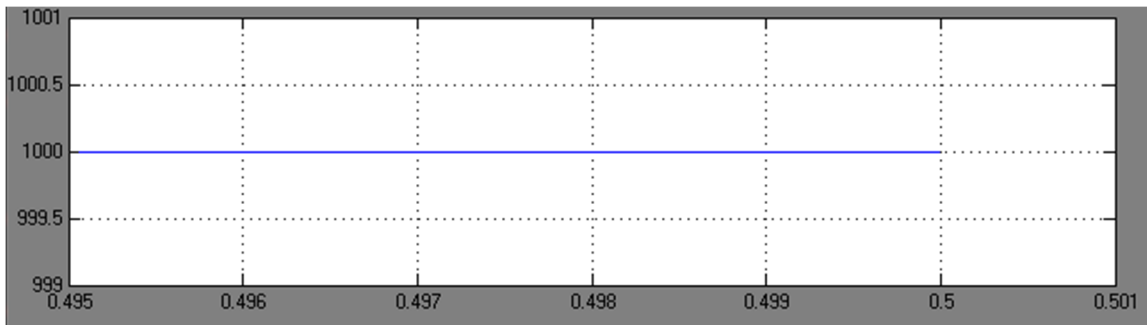

Figure 4.8: Insolation of the PV Array

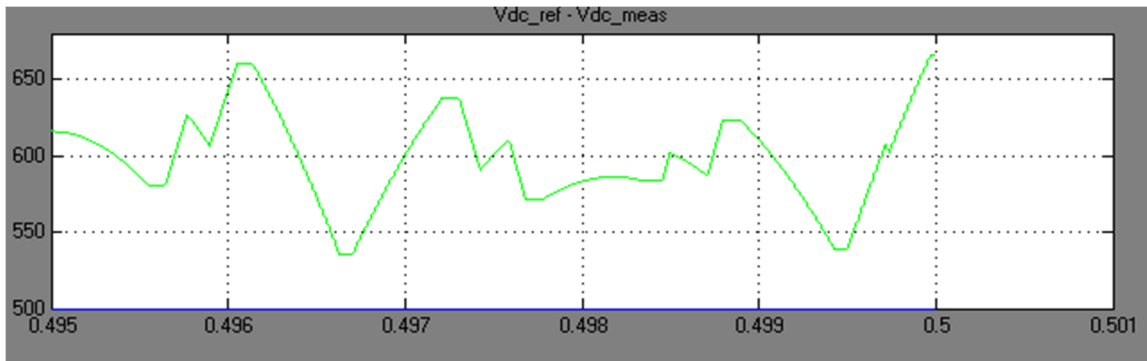

Figure4.9: Ref. voltage & mean voltage of the PV Array

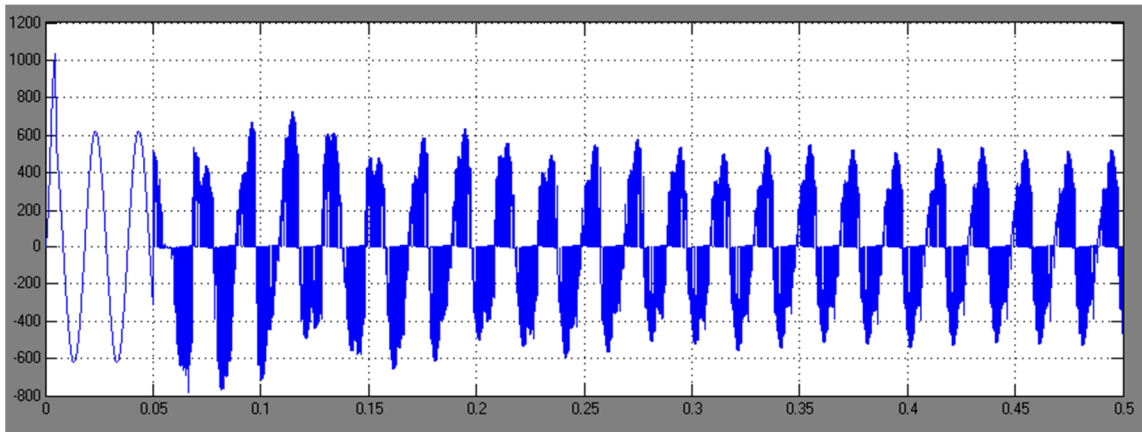

Figure4.10: Voltage of VSC Control in PV Array

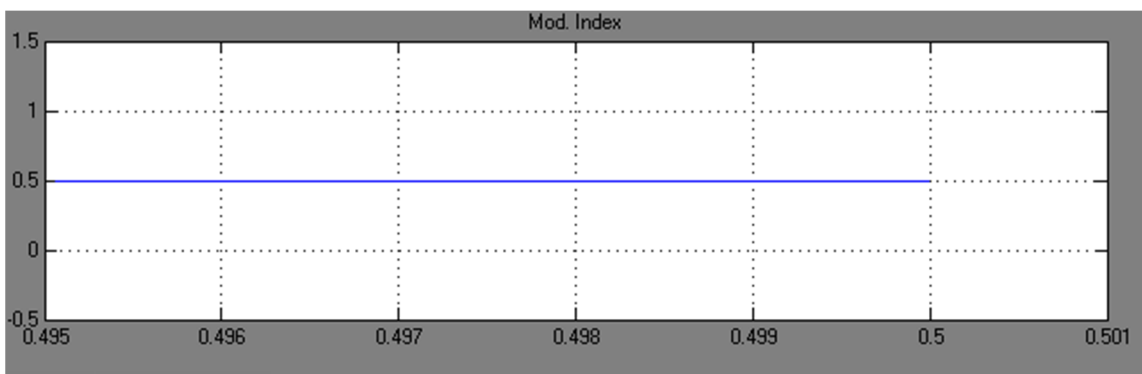

Figure 4.11: Modulation index of the PV Array

5.1 Conclusion

Solar PV is a technology that offers a solution for a number of problems associated with fossil fuels. It is clean decentralized, indigenous and does not need continuous import of a resource. On top of that, India has among the highest solar irradiance in the world which makes solar PV all the more attractive for India. The state of Orissa and Andhra Pradesh also houses some of the best quality reserves of silica.

India have a large number of cells and modules manufacturers. In spite of all above advantages Indian Photo Voltaic programme is still in the inferior stage. One of the reasons could be absence of simple, action oriented and aggressive PV policy of the country both in the state and central level. More quickly we do it with the professionals more we protect our future energy security.

5.2 Future scope of work

The work presented in this thesis can be further extended in the following areas in space satellites and orbital stations that involve large amount of money, the costs and complexity of the MPP tracker are not as important as its performance and reliability. Since the load in solar vehicles consists mainly of batteries, load current or voltage maximization should also be considered. The goal when using PV arrays in residential areas is to minimize the payback time and to do so, it is essential to constantly and quickly track the MPP.

- Scalable modular power electronics that is the use distribution dc-dc conversion.
- Much improved performance in the presence of module mismatches or partial shading.
- The maximum power point tracker finds the Maximum Power Point (MPP) in order to draw the maximum power from the solar array.

REFERENCES

- [1] Best practice guide-Photovoltaics PV
- [2] Roger A. Messenger and Jerry Ventre , “Photovoltaic systems engineering” ,CRC press page(s), 2004.
- [3]F. Harashima and H. Inaba, “Microprocessor-Controlled SIT Inverter for Solar Energy System”, IEEE Trans. on Industrial Electronics, vol. IE-34, no. 1, page(s):50-55, Feb,1985.
- [4] B.K.Bose, P.M.Szczesny and R.L.Steigerwald,“Microcomputer Control of a Resi-dential Photovoltaic Power Conditioning System”, IEEE Trans. on Industry Applications, vol. IA-21,110. 5, page(s):1182-1191, Sep,1985.
- [5] Z. Salameh, F.Dagher and W.A.Lynch, “Step-Down Maximum Power Point Tracker for Photovoltaic System”, Solar Energy, vol. 46, no. 1, page(s):278-282,1991.
- [6] Atiqah Hamizah, Mohd Nordin and Maliki Omar, “Modeling and Simulation of Photovoltaic (PV) Array and Maximum Power Point Tracker (MPPT) for Grid-Connected PV System” 3rd International Symposium & Exhibition in Sustainable Energy & Environment, 1-3 June 2011.
- [7] Xiaogao Chen, Qing fu, Shijie yu and Longhua Zhou, presented a paper about on “unified control of photovoltaic grid connection and power quality managements”, Workshop on Power Electronics and Intelligent Transportation System, 2008.
- [8]T. ESRAM and P. L. Chapman, "Comparison of Photovoltaic Array Maximum Power Point Tracking Techniques," IEEE transactions on energy conversion, vol. 22, no. 2, page(s): 439-449, Jun 2007.
- [9] M.Lokanadham and K.Vijaya Bhaskar, “ Incremental Conductance Based Maximum Power Point Tracking (MPPT) for Photovoltaic System” International Journal of Engineering Research and Applications (IJERA) ISSN: 2248-9622 www.ijera.com Vol. 2, Issue 2, page(s): 1420-1424,Mar-Apr2012.
- [10]J.A.Jiang “.Maximum Power Tracking for Photovoltaic Power Systems,” Tamkang Journal of Science and Engineering, Vol. 8, No. 2, page(s): 147-153, 2005.
- [11] H. Sugimoto and H. Dong, “A new scheme for maximum photovoltaic power tracking control,” Power Conversion Conference Proceedings of IEEE vol.2, page(s): 691-696, 1997.
- [12] C. Hua and C. Shen, “Comparative Study of Peak Power Tracking Techniques for Solar Storage System”, Proceedings of the IEEE Applied Power Electronics Conference, vol.2, page(s): 679-685, 1998.
- [13] Triplehelixblog.com (figure1.1)

- [14] Greencleanguide.com (figure1.2)
- [15] Polarpower.com (figure2.1)
- [16] Homesolarpvpanels.com (figure2.2)
- [17] Polarpower.com (figure2.3)
- [18] Polarpower.com (figure2.4)
- [19] Polarpower.com (figure2.5)
- [20] Digtheheat.com (figure2.6)
- [21] Homesolarpvpanels.com (figure2.7)
- [22] Homesolarpvpanels.com (figure2.8)
- [23] En.wikipedia.com (figure2.9)