

**“CAPACITY ANALYSIS OF MIMO(8X8) SYSTEM
WITH OR WITHOUT CSI UNDER DIFFERENT WIRELESS FADING CHANNELS”**

*Thesis submitted in partial fulfilment of the requirement for the award of
degree of*

MASTER OF ENGINEERING

In

ELECTRONICS & COMMUNICATION ENGINEERING

Submitted by

Vivek Mankotia

Roll no. 801161030

Under the Guidance of

Ankush Kansal

Assistant Professor

ECED

Thapar University



Electronics and Communication Engineering Department

Thapar University, Patiala-147004 (INDIA)

July 2013

DECLARATION

I hereby declare that the work which is being presented in the dissertation entitled, "CAPACITY ANALYSIS OF MIMO (8X8) SYSTEM WITH OR WITHOUT CSI UNDER DIFFERENT WIRELESS FADING CHANNELS" in partial fulfillment of the requirement for the award of degree of Master of Engineering in EC submitted in Electronics and Communication Engineering Department of Thapar University, Patiala, is an authentic record of my own work carried out under the supervision of **Ankush Kansal, Assistant Professor, ECED** and refers other researcher's work which are duly listed in the reference section.

The matter presented in this dissertation has not been submitted in any other University/Institute for the award of degree.

Date: 15/7/2013

(VIVEK MANKOTIA)

Roll No: 801161030

It is certified that the above statement made by the student is correct to the best of my knowledge and belief.

(Ankush Kansal)

Assistant Professor
ECED, Thapar University

Countersigned by:

Head
ECED, Thapar University
Patiala-147004

Dean of Academic Affairs
Thapar University
Patiala- 147004

Acknowledgement

First of all, I would like to express my gratitude to **Ankush Kansal, Assistant Professor**, Electronics and Communication Engineering Department, Thapar University, Patiala for his patient guidance and support throughout my work. I am truly very fortunate to have the opportunity to work with him. I found his guidance to be extremely valuable.

I am also thankful to our **Head of the Department, Dr. Rajesh Khanna**, Electronics and Communication Engineering **Department, entire** faculty and staff of Electronics and Communication Engineering Department. I would also like to thank my friends who devoted their valuable time and helped me in all possible ways towards successful completion of this work. I thank all those who have contributed directly or indirectly to this work.

Lastly, I would like to thank my parents for their unconditional support and encouragement.



VIVEK MANKOTIA

Roll No . 801161030

ABSTRACT

In current time Multiple Input Multiple Output (MIMO) wireless links has emerged as one of the most significant technical breakthrough in modern communication. In this thesis, an overview of MIMO system has been discussed. After presenting brief idea of MIMO system Transmissions, the system Capacity and Bit Error Rate (Detection Techniques) of MIMO designs have been explained. Multiple antennas have been used to increase diversity to combat channel fading. Hence, a MIMO system can provide two types of gains: spatial multiplexing or capacity gain and diversity gain. However, the capacity and diversity benefits of MIMO systems depend on what kind of fading(Rayleigh and Rician) the channels undergo; whether the fades associated with different transmit and receive antennas are correlated; and whether the channel state information (CSI) is available at the transmitter or not available at transmitter. This thesis presents the progress we have made towards determining the capacity and diversity benefits of multiple antennas under different assumptions about the fading channel. In this thesis work capacity analysis of MIMO (8X8) system with or without CSI under different wireless fading MIMO system had been done. Rayleigh and Rician fading channel has been taken between (8X8) transmitter and receiver. This thesis also represent work regarding to Beamforming. Wireless relaying networks had recently been given considerable benefits over traditional communication system. The relaying terminals forward the information from the source to the destination mainly using the Amplify-Forward method. The main aim of MIMO system is to increase the diversity gain and range of system. Here, in this thesis slow and frequency non selective Rician fading channel is assumed, and the effect of Rician factor (K) on the capacity and diversity gains of correlated MIMO channels is investigated. Thesis presents the view point that the loss or gain in the capacity or diversity can be considered as an equivalent increase or decrease in the signal-to-noise power ratio (SNR). For $N_t \times N_R$ MIMO systems, as value of k increases the ergodic capacity and outage capacity decreases. If value of correlated fading parameter (r) increases, the ergodic and the outage capacity decreases. When transmitter know the CSI capacity increases as compare when transmitter does not know the CSI. When transmitter does not know the CSI at that time equal power is given to each transmitter. The bit error rate analysis of MIMO system have been analyzed using BPSK modulation scheme over Rayleigh and Rician wireless fading channels. The BER performance characteristics

investigation of 8x8 antenna configuration had done by using different type of linear and non-linear equalizer techniques namely ML, ZF and MMSE for MIMO system.

In the case of MIMO (4,3) when CSI is not present at transmitter then at SNR (dB) 5, 10 the capacity results for Rayleigh channels are 4(bps/Hz), 13(bps/Hz). But in case of (8x8) MIMO capacity become 13.5(bps/Hz) , 22 (bps/Hz) for taking same condition. When transmitter know the CSI then at 5(dB), 10(dB) the capacity for MIMO(8X8) become 29.5 (bps/Hz) , 41(bps/hz). So there is increase in capacity when number of transmitter and receiver increases. In case of Rician channel at 30(dB),k=0 the capacity for(8x8) is 70(bps/Hz),at k=3 the capacity is 59(bps/hz) and at k=7 capacity becomes 52(bps/Hz).As value of k increases the capacity of Rician fading channel continuously decreases. The capacity of MIMO (8x8) for k=10 ($r_t=0.5, r_r=0.5$) at 30 (dB) become 59(bps/Hz) .Increasing channel correlation (r) reduces the capacity of the system. Ergodic capacity of MIMO (8x8) when there are eight relay between transmitter and receiver at 30 (dB) is 28(bps/Hz). Ergodic capacity of MIMO(8x8) when there are four relay between transmitter and receiver at 30 (dB) is 24(bps/hz). So as number of relay between transmitter and receiver increases it increases the capacity. The BER rate of MMSE detection techniques for MIMO (8X8) is less than as compare of BER for ZF detection techniques at same SNR.

Table of Content

Abstract.....	i
Table of Content.....	iii
List of Figures.....	v
CHAPTER 1.....	1
INTRODUCTION.....	1
1.1 Evolution of Wireless Communication.....	1
1.2 MIMO SYSTEM.....	2
1.3 Types of MIMO CHANNEL.....	3
1.3.1 SISO (Single Input Single Output).....	3
1.3.2 MISO (Multiple Input Single Output).....	4
1.3.3 SIMO (Single Input Multiple Output).....	4
1.4 Characteristics OF MIMO.....	5
1.4.1 Beam Forming.....	5
1.4.2 Spatial Multiplexing.....	6
1.4.3 DIVERSITY.....	6
1.5 Motivation.....	8
1.6 Gaps.....	10
1.7 Methodology of Thesis.....	10
1.8 Organization of Thesis.....	10
CHAPTER2.....	11
Literature Survey.....	11
2.1 Objectives ofThesis.....	18
CHAPTER 3.....	19
MIMO System.....	19
3.1 MIMO SYSTEM BASIC.....	19
3.2 MIMO System.....	19
3.3 MIMO Transmission.....	21
3.4 Small scale fading.....	22
3.4.1 Fast Fading.....	23
3.4.2 Slow Fading.....	23

3.4.3 Frequency Selective Fading	24
3.4.4 Flat Fading	24
3.5 Diversity Techniques	25
3.6 Types of Diversity.....	25
3.6.1 Macroscopic diversity scheme.....	25
3.6.2 Microscopic diversity scheme.....	26
3.7 MIMO Diversity Techniques	30
3.7.1 Transmit Diversity.....	30
3.7.2 Receive Diversity.....	31
3.8 MIMO Spatial Multiplexing Techniques.....	34
3.9 Advantages of MIMO Systems.....	34
Chapter 4.....	36
Capacity and BER Analysis.....	36
4.1 Introduction	36
4.2 Deterministic MIMO Channel Capacity	37
4.2.1 CSI Is Not Available At Transmitter for Channel Calculation	38
4.2.2 Transmitter Knows The CSI for Capacity Analysis	39
4.2.3 Channel Capacity With and Without CSI	40
4.2.4 EFFECT of Correlation on MIMO	41
4.2.5 Ergodic Capacity.....	42
4.3 Relay MIMO Network	42
4.4 Beam Forming	44
4.5 Outage Capacity.....	45
4.6 Rician Channel.....	45
4.7 Equalization (detection) TECHNIQUES	46
4.7.1 Types of MIMO Equalizer	48
Chapter 5 Results	54
Chapter 6 Conclusion and Future scope.....	66
References.....	68

LIST OF FIGURES

Figure 1: MIMO System.....	3
Figure 2: SISO(Single Input Single Output).....	3
Figure 3: MISO(Multiple Input Single Output).....	4
Figure 4:SIMO(Single Input Multiple Output).....	4
Figure 5: Beamforming	5
Figure 6: Space Diversity	6
Figure 7; Frequency Diversity	7
Figure 8: MIMO System.....	19
Figure 9 MIMO Model.....	20
Figure 10 : Data tranasmission in MIMO system.....	21
Figure 11 : Multipath propagation of a signal	23
Figure 12 : Frequency Diversity	27
Figure 13: Polarization Diversity	28
Figure 14: Angle Diversity	28
Figure 15: Space Diversity	29
Figure 16 : Transmit Diversity.....	30
Figure 17: Receive Diversity : Selection Combining.....	31
Figure 18: Receive Diversity: maximal ratio combining	33
Figure 19 Spatial Multiplexing System.....	34
Figure 20: MIMO Rayleigh Channel Model	36
Figure 21: Transmitter know the CSI.....	39
Figure 22: r virtual SISO channels obtained from model decomposition of MIMO channel.....	40
Figure 23: RELAY MIMO	42
Figure 24 : MIMO(8X8).....	49
Figure 25: Shanon capacity vs. SNR(dB).....	54
Figure 26: Ergodic channel capacity when CSI is not available at transmitter	55
Figure 27; Ergodic channel capacity when CSI is available at transmitter	56
Figure 28: Distribution of MIMO channel capacity.....	56
Figure 29: Channel unknown and known.....	57

Figure 30: Effect of Correlation.....	58
Figure 31; Outage capacity vs. SNR.....	59
Figure 32 : Capacity analysis of uncorrelated Rician channel when CSI is not present at transmitter.....	59
Figure 33: Rician channel capacity when transmitter knows the CSI under different correlation parameter.....	60
Figure 34 : Beamforming.....	61
Figure 35: Ergodic channel capacity vs. SNR in dB.....	62
Figure 36: ZF Detection for multiplexing and diversity techniques.....	63
Figure 37 : Comparison between ZF and MMSE Detection.....	64
Figure 38: BER for ML detection techniques.....	65

LIST OF ABBREVIATIONS

MIMO	Multiple Input Multiple Output
1G	First Generation
FDMA	Frequency Division Multiple Access
TDMA	Time Division Multiple Access
CDMA	Code Division Multiple Access
3G	Third Generations
QOS	Quality of Service
SVD	Singular Value Decomposition
SISO	Single Input Single Output
SIMO	Single Input Multiple Output
MISO	Mingle Input Multiple Output
SM	Spatial Multiplexing
PAN	Personal Area Network
LAN	Local Area Network
WAN	Wireless Area Network
MAN	Metropolitan Area Network
i.i.d	Independent and Identically Distributed
LOS	Line of Sight
SNR	Signal to Noise Ratio
MI	Mutual Information
BER	Bit Error Rate
AF	Amplify and Forward
ZF	Zero forcing
ML	Maximum likelihood
MMSE	Minimum Mean Square Error-Estimator
IEEE	Institute of Electrical and Electronics Engineers
BPSK	Binary Phase Shift Key
ZMCSG	Zero mean Circularly Symmetric Complex Gaussian RandomVariables

CSI	Channel State Information
IRQ	Improved Rate Quantization
ISI	Inter Symbol Interference
WLAN	Wireless Local Area Network
AWGN	Adaptive White Gaussian Noise

CHAPTER 1

INTRODUCTION

In the most general sense, a wireless system is any collection of elements (or subsystems) that operate interdependently and use unguided electromagnetic-wave propagation to perform some specified function. Systems that convey information between two or more locations, such as personal communication systems (PCS), police and fire department radio systems, commercial broadcast systems, satellite broadcast systems, telemetry and remote monitoring systems are example of wireless system. Systems that sense the environment and/or objects in the environment, including radar systems that may be used for detecting the presence of objects in some region or volume of the environment and measuring their relative motion and/or position, systems for sensing or measuring atmospheric conditions, and systems for mapping the surface of the Earth or planets are wireless system. Systems that aid in navigation or determine the location of an object on the Earth or in space. Multi-carrier modulation (MCM) is a method of transmitting data by splitting it into several components, and sending each of these components over separate carrier signals. The individual carriers have narrow bandwidth , but the composite signal can have broad bandwidth.

1.1 Evolution of Wireless Communication

Wireless communication systems have made large advances since the first generation (1G) Systems. Frequency Division Multiple Access (FDMA) was the main techniques used at that Level. Similarly, Time Division Multiple Access (TDMA) and Code Division Multiple Access (CDMA) multiple access techniques are widely used in today's communication systems, which is the second generation (2G) systems [1]. CDMA is also used in the third generation (3G) systems. These three main multiple access schemes are used to allow users to simultaneously share radio spectrum, which is an finite and essential resource of all wireless communications technologies. Nowadays, the wireless system designers are faced with several challenges. The limitation of the radio spectrum and the complexity of wireless propagation environment, moreover the increasing demand for better quality of service (QoS)

and higher transmission data rate. Designers have divided frequency, time and code. Traditional wireless communication systems have been made more spectrally efficient through the use of clever coding techniques and algorithms. However, the fundamental bandwidth limitation does not change. Multiple Input Multiple Output (MIMO) communication systems have been an increasingly hot topic of research over the past years, due to their ability to greatly increase spectral efficiencies. As opposed to traditional wireless systems, in which there is one transmitting and one receiving antenna, MIMO systems use arrays of multiple antennas at both ends of the communication link, all operating at the same frequency at the same time[2][3]. This introduces spatial diversity into the system, which can be used to tackle the problem of multipath. In wireless communications system, such as point to point radio links, radio waves do not simply propagate from the transmit antenna to the receive antenna. Rather they bounce and scatter off objects, this effect is known as multipath. This effect is regarded as an impediment to the accurate transmission of data in traditional wireless links [4]. MIMO systems exploit multipath by using the rich scattering environment to increase the spectral efficiency of the wireless system. The modeling of radio waves on a large scale can be very complex. There is however, a simplification. At high frequencies radio waves can be approximated as travelling along localized paths. This is similar to the geometrical treatment of light rays in optics. Complex radio environments can be modeled by different deterministic and stochastic model. Signal processing at both ends of a MIMO wireless link are encode and decode by the singular value decomposition (SVD) and correlation. In this Report, an attempt is made to demonstrate the effect of correlation between the elements of the channel matrix on important wireless system performance criteria such as channel capacity and bit error rate.

1.2 MIMO SYSTEM

Multiple antennas can be used at the transmitter and receiver, an arrangement called a MIMO system. A MIMO system takes advantage of the spatial diversity that is obtained by spatially separated antennas in a dense multipath scattering environment. MIMO systems may be gain to combat signal fading or to obtain a capacity gain. Generally, there are three categories of MIMO technique the first aims to improve the power efficiency by maximizing spatial diversity. Such techniques include delay diversity, STBC, and STTC. The second class uses a

layered approach to increase capacity. One popular example of such a system is V-BLAST , Where full spatial diversity is usually not achieved. Finally, the third type exploits the knowledge of channel at the transmitter. It decomposes the channel coefficient matrix using SVD.

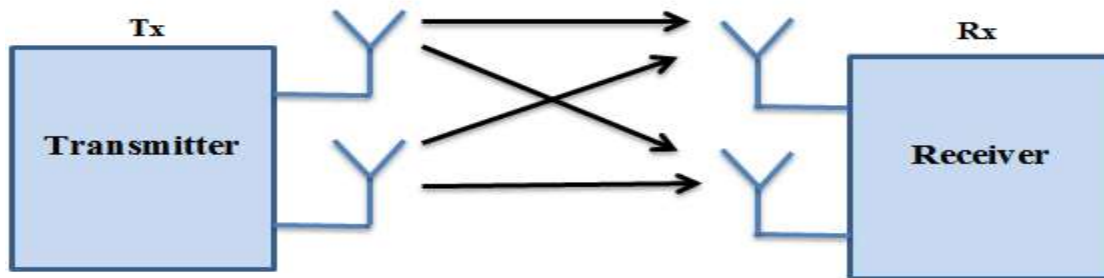

Figure 1: MIMO System

1.3 Types of MIMO CHANNEL

MIMO channel are defined as how many antenna are present at transmitter and receiver end

1.3.1 SISO (Single Input Single Output)

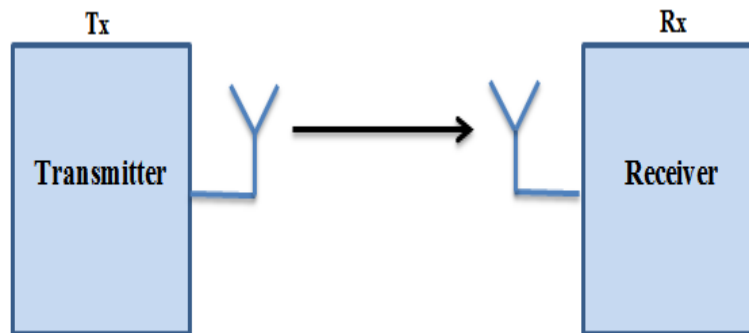

Figure 2: SISO(Single Input Single Output)

Refers to a wireless communications system in which one antenna is used at the source (transmitter) and one antenna is used at the destination (receiver)[2]. SISO is the simplest antenna technology.

1.3.2 MISO (Multiple Input Single Output)

Is an antenna technology for wireless communications in which multiple antennas are used at the source (transmitter). The antennas are combined to minimize errors and optimize data speed [2]. The destination (receiver) has only one antenna. MISO is one of several forms of smart antenna technology. MISO technology has widespread applications in digital television (DTV), wireless local area networks (WLANs), metropolitan area networks (MANs), and mobile communications.

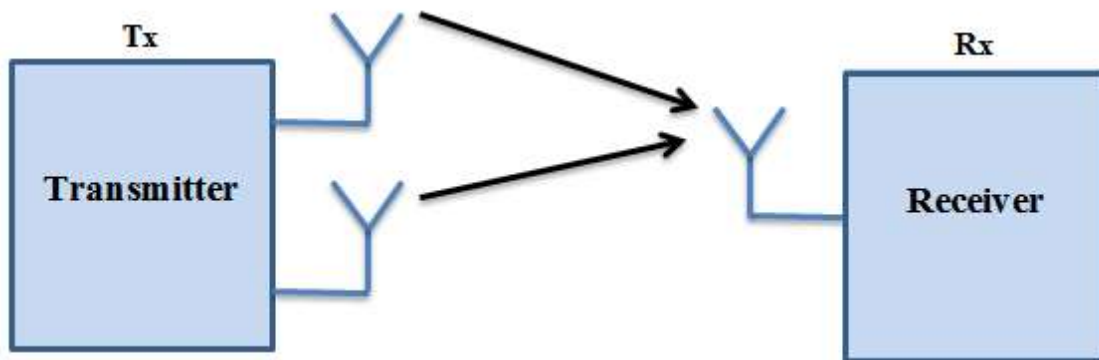

Figure 3: MISO(Multiple Input Single Output)

1.3.3 SIMO (Single Input Multiple Output)

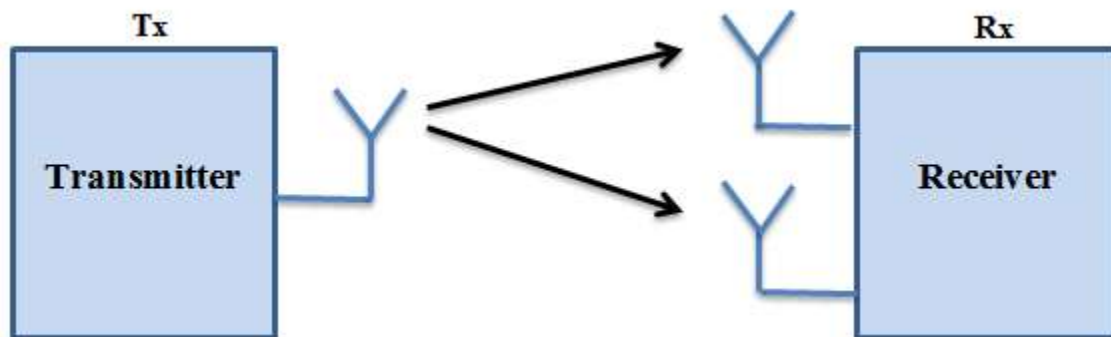

Figure 4: SIMO (Single Input Multiple Output)

Is an antenna technology for wireless communications in which multiple antennas are used at the destination (receiver). The antennas are combined to minimize errors and optimize data speed. The source (transmitter) has only one antenna. SIMO is one of several forms of smart

antenna technology, the others being MIMO (multiple input, multiple output) .SIMO technology has widespread applications in digital television (DTV), wireless local area networks (WLANs), metropolitan area networks (MANs), and mobile communications.

I.4 Characteristics of MIMO

Beamforming, spatial multiplexing, Diversity are characteristics of MIMO system.

1.4.1 Beam Forming

In beam forming same signal is emitted from each of the transmit antennas with appropriate phase (and sometimes gain) weighting such that the signal power is maximized at the receiver input [6]. The benefits of beam forming are to increase the received signal gain, by making signals emitted from different antennas add up constructively, and to reduce the multipath fading effect. In the absence of scattering, beamforming results in a well-defined directional pattern, but in typical cellular conventional beams are not a good analogy. When the receiver has multiple antennas, the transmit beam forming cannot simultaneously maximize the signal level at all of the receive antennas.

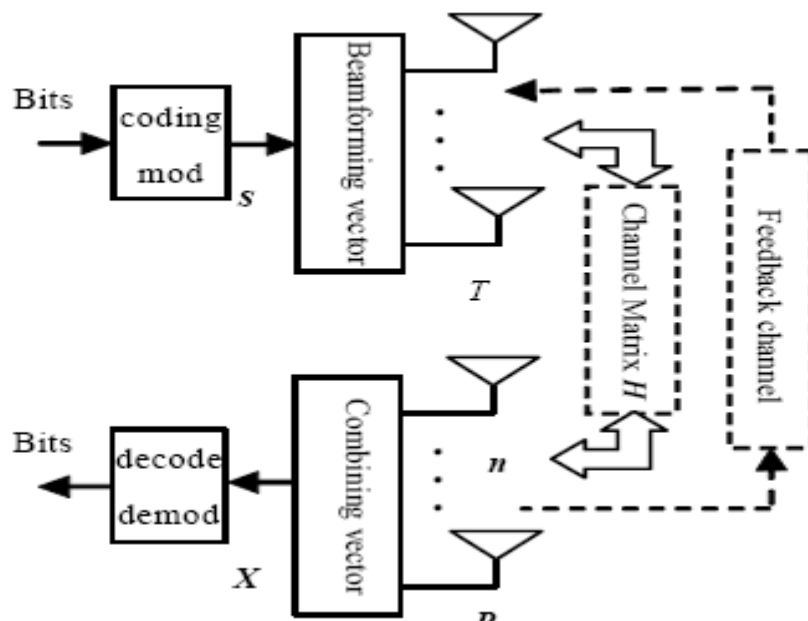

Figure 5: Beamforming [6]

1.4.2 Spatial Multiplexing

A high rate signal is split into multiple lower rate streams and each stream is transmitted from a different transmit antenna in the same frequency channel [5]. If these signals arrive at the receiver antenna array with sufficiently different spatial signatures, the receiver can separate these streams into (almost) parallel channels. Spatial multiplexing is a very powerful technique for increasing channel capacity at higher signal-to-noise ratios (SNR). Spatial multiplexing can be used with or without transmit channel

1.4.3 DIVERSITY

Each pair of transmit-receive antennas provides a signal path from transmitter to receiver. By sending the same information through different paths, multiple independently-faded replicas of the data symbol can be obtained at the receiver end[7]. Hence, more reliable reception is achieved diversity gain d implies that in the high SNR region, my P_e decays at a rate of $1/\text{SNR}^d$ as opposed to $1/\text{SNR}$ for a SISO system The maximal diversity gain d_{max} is the total number of independent signal paths that exist between the transmitter and receiver .For an (M_R, M_T) system, the total number of signal paths is $M_R M_T$

$$1 \leq d \leq d_{max} = M_R M_T$$

The higher my diversity gain, the lower my P_e

Space diversity:

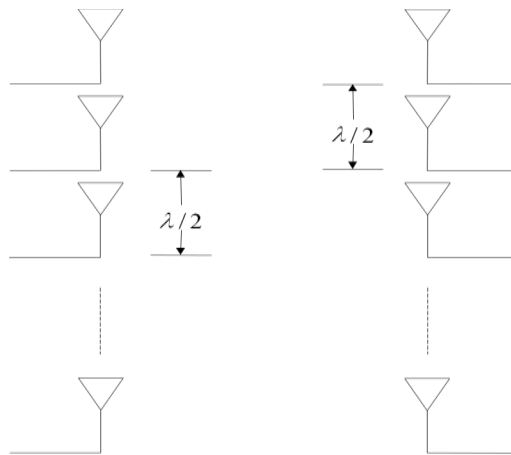

Figure 6: Space Diversity

Redundancy is provided by employing an array of antennas, with minimum separation of $\lambda/2$ between neighbouring antennas [1]. Differently polarized antennas can also be used. Antenna

diversity, also known as space diversity, is any one of several wireless diversity schemes that uses two or more antennas to improve the quality and reliability of a wireless link. Often, especially in urban and indoor environments, there is no clear line-of-sight (LOS) between transmitter and receiver. Instead the signal is reflected along multiple paths before finally being received. Each of these bounces can introduce phase shifts, time delays, attenuations, and distortions that can destructively interfere with one another at the aperture of the receiving antenna. Antenna diversity is especially effective at mitigating these multipath situations. This is because multiple antennas offer a receiver several observations of the same signal. Each antenna will experience a different interference environment. Thus, if one antenna is experiencing a deep fade, it is likely that another has a sufficient signal. Collectively such a system can provide a robust link. While this is primarily seen in receiving systems (diversity reception)

Polarization diversity:

Transmit and/or receive with both vertical and horizontal polarization [1]. Scattering is independent for each polarization, giving independent paths. This technique requires information to be transmitted using two different polarizations of E-M wave (Electromagnetic wave). Unlike space diversity distance between antennas is not a constraint for optimum functioning of the polarization diversity in the wireless system to help recover transmitted data at receiver end. For good performance antennas should be orthogonally polarized, as in this way about 30dB difference of signal strength is exhibited at receiver between these two orthogonally polarized conditions.

Frequency Diversity

Same information is transmitted on different frequency carriers, which will face different multipath fading. Transmit same signal with several frequencies [1]. Frequencies separated by greater than coherence bandwidth.

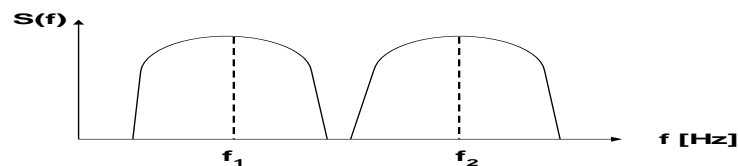

Figure 7; Frequency Diversity

This radio diversity option uses a single antenna with two simultaneous frequency channels. As the likelihood is that the signals will not suffer the same level of attenuation at different frequencies, the receiver with the strongest signal “assumes control” of the transmission. Like space diversity, frequency diversity requires a second receiver. But it also requires double the spectrum usage – and this is generally less favored by regulators. Frequency diversity relies on the fact that the fading is different at different frequencies. It is sometime said that it is not correlated. Hence when there is a fade at one frequency, there may not be a fade at another. To make use of this, you simply transmit your signal on two frequencies; p At the receiving end, a circuit measures the signal-to-noise ratio in two receivers and automatically selects which is best at any instant in time. This works well but it is rather inefficient to have the same information transmitted on two frequencies.

Time diversity

Transmit the desired signal in M different period of time. In which each symbol is transmitted M times [1]. Signal is re-transmitted (repeated) after greater than coherence time .It is achieved using coding and interleaving. It reduces overall transmission data rates. Information is divided and sent across the channel at different time instants. This type of diversity is useful in the time varying channel environment where the data are more corrupted at one time instant but will be less corrupted at other time instant. As different time instants sees channel differently it helps to recover the information in totality at the receiver end. Time Diversity is used in digital communication systems to combat that the transmissions channel may suffer from error bursts due to time-varying channel conditions. The error bursts may be caused by fading in combination with a moving receiver, transmitter or obstacle, or by intermittent electromagnetic interference, for example from crosstalk in a cable, or co-channel interference from radio transmitters. Time diversity implies that the same data is transmitted multiple times, or a redundant error correcting code is added. By means of bit-interleaving, the error bursts may be spread in time.

1.5 Motivation

In the light of the above description of the current wireless networks, one can conclude that despite significant improvement on the provision of wireless services, there is an underlying strong demand for higher data rate wireless services, mainly driven by wireless data

applications, as well as users' expectation of wire-equivalent quality wireless service. Providing such high-rate high-quality wireless services is extremely challenging due to the inherent harsh wireless propagation environment. Compared to wired communication, wireless communication faces two fundamental problems that make fast and reliable wireless connection difficult to achieve, namely, interference and fading (variation of the channel strength over time and frequency due to the small-scale effect of multipath fading, as well as larger-scale fading effects such as path loss via distance attenuation and shadowing by obstacles such as tall buildings and mountains). In addition, wireless communication is required to carefully address the resource management problem, i.e. how to efficiently allocate and utilize power and spectrum (two principle resources in wireless communication). Responding to these challenges, multiple-input multiple-output (MIMO) antenna systems were proposed independently by Telatar [9] and Foschini and Gans [8]. By introducing multiple antennas at both sides of the communication link, MIMO systems are able to substantially increase data rate and improve reliability without extra spectrum and power resources. The remarkable prospect of MIMO systems has not only sparked huge research interests in the research community, but also attracted enormous attentions from the industry and has led to practical implementation in real communication systems. For instance, MIMO technology has already been incorporated into various industry standards, In general, MIMO technology is likely to become a prominent feature of future wireless communication systems. The huge potential of MIMO technology has sparked a surge of research activities, which greatly strengthen our understanding of the fundamental limits and performance of MIMO channels. However, most of these research works are based on a relatively simple channel model; for instance, the channel is assumed to be a single random matrix and is subjected to Rayleigh fading or Rician fading. On the other hand, the increasing popularity of MIMO technology calls for a better understanding of the performance of MIMO systems operating in more practical environments. Motivated by this, this thesis looks into several general and practical channel models, such as Rayleigh and Rician MIMO fading channels, and investigates the fundamental capacity of MIMO system with or without CSI. The objective of the thesis is to enhance our understanding of MIMO systems operating in these general MIMO channels, and to derive a set of new analytical results for understanding the performance of these advanced MIMO systems.

1.6 Gaps

As number of transmitter and receiver increases there is increase in channel capacity and reduction in BER but due to increase in channel capacity complexity of system increase because there are increase in RF link. More power is required for more number of transmitter and receiver. Water pouring principle can be used when transmitter know the CSI. But at higher SNR capacity become equal with and without CSI using water pouring principle. Multiuser MIMO user system is largely unexplored and need to be explored. Transmitter synchronization in multiuser communication is very difficult and need attention either by linear or non- linear preceding methods. In spatial multiplexing, a high rate signal is split into multiple lower rate streams and each stream is transmitted from a different transmit antenna in the same frequency channel but it is not always possible to maintain spatial multiplexing.

1.7 Methodology of Thesis

In this thesis, the overview of MIMO system as well as the capacity (8X8) and bit-error-rate has been thoroughly investigated. Further, the techniques have been described with mathematical modeling and closed form expressions capacity for Rayleigh Channels, beamforming, relay MIMO and for Rician channels have been described. Capacity under Rayleigh fading channel and Rician channel has been experimentally computed with and without CSI at transmitter. Then linear and non-linear detection based techniques are utilized for calculating and analysis of bit error rate.

1.8 Organization of Thesis

The thesis is organized into six chapters. Chapter 1: introduces the MIMO system and Brief idea of diversity, spatial multiplexing and beamforming. Chapter 2: discusses the literature survey of MIMO capacity and BER. In Chapter 3. The overview of MIMO system with diversity, fading has been discussed Chapter 4: discusses the analysis and of MIMO capacity under Rayleigh fading and Capacity for correlated Rician fading channel. It discusses the bit error rate for MIMO (8X8) detection techniques. Chapter 5: discusses the analysis and simulation of MIMO (8x8) capacity and equalization techniques. Chapter 6: provides a Conclusion and gives recommendations for future study.

CHAPTER 2

Literature Survey

H.Foschini *et al.* [8] analyzed that capacity of a multiple-antenna point to point wireless system in a narrow-band slowly Rayleigh-fading environment. They suppose independent and identically distributed (i.i.d.) fading at different antenna elements, and assume that the transmitter does not know the channel while the receiver is able to track the channel perfectly. With T transmit and R receive antennas, the system is described by the matrix equation

$$Y = \sqrt{\frac{E_s}{T}} Hx + n \quad (2.1)$$

where E_s is the total energy available at the transmitter, y is the $R \times 1$ vector of signals received on the R antennas, x is the $T \times 1$ vector of signals transmitted on the T transmit antennas, n is the $R \times 1$ noise vector consisting of independent complex Gaussian distributed elements with zero mean and variance σ^2 , and H is the $R \times T$ channel matrix. The capacity for this system is shown to be

$$C = \log_2 E_H \left[\det \left(I_n + \frac{\rho}{N_t} V \right) \right] \quad (2.2)$$

$$V = HH^H N_r \leq N_t$$

$$V = H^H H N_r > N_t \quad (2.3)$$

$$\rho = \frac{E_s}{\sigma^2}$$

Where $E_H\{.\}$ denote the expectation over H , $m = \min(N_t, N_r)$ and the operator indicates the hermitian of the matrix H . The above equation can be decomposed using singular value decomposition (SVD)

$$C = E_H \sum_{i=1}^k \log_2 \left(1 + \frac{\rho}{N_t} \beta_i \right) \quad (2.4)$$

Teletar *et al.* [9] proposed that when the (CSI) is available at the transmitter, the capacity given can be increased by given the transmitted power to various antennas according to the “water-filling” algorithm. In the case of water pouring principle the channel parameter are

known to transmitter and more power is given to that channel which is in good condition or less or none which is in bad condition

$$C = E_H \left(\int_{i=1}^k \log_2(\mu \lambda_i)^+ \right) \quad (2.5)$$

μ is chosen

$$\rho = \sum_{i=1}^k (\mu - \lambda_i^{-1})^+ \quad (2.6)$$

+ denotes the positive term.

While Da-Shan *et al.* [11] modeled the MIMO correlated fading as

$$H_{\text{corr}} = R_r^{1/2} H_W R_t^{1/2} \quad (2.7)$$

Where R_t and R_r are the correlation matrix at the transmitter and at the receiver side, respectively. The MIMO channel capacity in correlated channels using the uniform and exponential correlation matrix model has been investigated by **Lokya *et al.* [10]**. Using uniform correlation matrix model, the correlation matrix R is defined as.

$$r_{ij} = \begin{cases} r & i \neq j \\ 1 & i = j \end{cases}, \quad |r| < 1 \quad (2.8)$$

While using exponential correlation model, the correlation matrix R is defined as

$$r_{ij} = \begin{cases} r^{i-j} & i \leq j \\ r_j^* & i > j \end{cases} \quad (2.9)$$

Where r is the correlated fading parameter between any two adjacent antennas, and “*” denotes the complex conjugate. As the correlation increases, the capacity decreases. In other words, the increase in correlation is equivalent to the decrease in SNR.

Farrokh *et al.* [12] modeled the Rician fading channel as

$$H = aH^{sp} + bH^{sc} \quad (2.10)$$

Where the specular [13] and scattered components of H are denoted by superscripts, $a > 0$, $b > 0$ and $a^2 + b^2 = 1$.

H^{sp} is a matrix of unit entries denoted as.

$$H = \sqrt{\frac{K}{K+1}} H_S + \sqrt{\frac{1}{K+1}} R_r^{1/2} H_d \quad (2.11)$$

Ayadi's *et al.* [14] state that they for Rician fading and with CSI being available only at the receiver

- Increase in Rician factor reduces the capacity of the MIMO system.
- Increase in Rician factor increase the capacity of the SIMO system.

Yonghua Li *et al.*[6] state that In mobile communication, space is a very important domain to use. Two kinds of leading techniques are beamforming and STBC in MIMO system. They investigate the relation between beamforming and STBC at the capacity perspective. Both techniques can improve system performance at the cost of the capacity, which shows that they convert the matrix channel into a scalar AWGN channel. At low SNR, the MIMO capacity is less than that of beamforming system, and vice versa in independent MIMO channel. But in highly correlated channel, the capacity of beamforming is larger than that of MIMO system, and MIMO capacity is same with that of STBC. It is proven that beamforming is robust at both independent and correlated channels, and STBC is optimal with respect to capacity when it is code rate one over a channel of rank one. Simulations are conducted at the actual applications.

Peter J. Smith *et al.* [15] state that It is well known that multiple input multiple output (MIMO) systems offer the promise of achieving very high spectrum efficiencies (many tens of bit/s/Hz) in a mobile environment. The gains in MIMO capacity are sensitive to the type of channel encountered in the radio environment. To date most analytical work has concentrated on Rayleigh fading channels. They consider the capacity outage performance of MIMO systems in Rician channels. Due to analytical complexity they concentrate on dual antenna systems (either two transmit or two receive antennas) and derive exact densities and distribution functions for the capacity.

Da-Shan Shiu *et al.* [16] investigate the effects of fading correlations in multi element antenna (MEA) communication systems. Pioneering studies showed that if the fades connecting pairs of transmit and receive antenna elements are independently, identically distributed, MEA's offer a large increase in capacity compared to single-antenna systems. An MEA system can be described in terms of spatial Eigen modes, which are single-input single-output sub channels. The channel capacity of an MEA is the sum of capacities of these sub

channels. They show that the fading correlation affects the MEA capacity by modifying the distributions of the gains of these sub channels. The fading correlation depends on the physical parameters of MEA and the scattered characteristics. They employ an abstract model, which is appropriate for modeling narrow-band Rayleigh fading in fixed wireless systems.

Rohit U. Nabar *et al.* [17] state that it is possible to assess the impact of real-world propagation conditions on the maximum achievable diversity performance of communication over Rician multiple input multiple-output (MIMO) channels. They examine a MIMO channel employing orthogonal space–time block codes (OSTBCs) and study the diversity behavior of the resulting effective single-input single-output (SISO) channel. The performance criteria employed are symbol error rate, outage capacity, and wideband spectral efficiency. For general propagation conditions, they establish key quantities that determine performance irrespective of the performance criterion used.

Ligang Ren *et al.* [18] state that Multiple Input Multiple Output (MIMO) systems that use antenna arrays at both the transmitter and receiver is gaining much more attention and efforts in wireless communication research due to their potential to increase considerably capacity in mobile cellular communications. However, in real propagation environment of cellular communications, it is difficult to gain the ideal ergodic capacity for the time-varying fading MIMO channels except using adaptive modulation and power water-filling in space domains over every MIMO sub channel. A novel Improved Rate Quantization (IRQ) algorithm using water filling theory for power allocation and adaptive modulation is proposed by them. They show that, with low complexity, IRQ can obtain higher transmit power utilization and greater spectral efficiency than other present rate quantization and power allocation scheme.

Alamouti *et al.* [19] presented a new diversity scheme (Alamouti's scheme). They assume independent and identically distributed (i.i.d.) fading at different antenna elements, and assume that the transmitter does not know the channel while the receiver is able to track the channel perfectly. The important results obtained were as follows

- Using two transmit antenna and one receive antenna, the new scheme provides the same order of diversity as the maximal-ratio receive combining (MRRC) with one transmit antenna and two receive antenna.

- The scheme can be easily generalized to two transmit antennas and R receive antennas to provide a diversity of $2R$.

Z. Xinyu *et al.* [20] analyze the capacity of the channel in MIMO system through the uniform angular energy distribution and correlation matrix that give the higher value of correlation between the channels and the smaller value of SNR. The expansion of radius and angle of the receiving antenna array is the key point of capacity of channel in MIMO system.

B. Holter *et al.* [21] analyzed that MIMO systems channel and found that MIMO offer a significant capacity gain over a traditional single-input single-output (SISO) channel. There is a linear increase in spectral efficiency compared to a logarithmic increase in more traditional systems which utilizing receiver diversity or no diversity. The high spectral efficiencies attained by a MIMO system are enabled in a rich scattering environment, the signals from each individual transmitter appear highly uncorrelated at each of the receive antennas. When the transmitted signals are conveyed through uncorrelated channels through the transmitter and receiver, the signals corresponding to each of the individual transmit antennas have attained different spatial signatures. The receiver can use these differences in spatial signature simultaneously and at the same frequency separate the signals that originated from different transmit antennas.

G. Taricco *et al.* [22] provided an asymptotic method to derive a very good approximation to the ergodic capacity of a MIMO communication system that was affected by additive noise, interference, Rician fading and spatial correlation (Kronecker model). The ergodic capacities are highly suboptimal if the interference power level is relatively high compared to the signal power level. The main reasons for the difficulty in analyzing MIMO system is the large number of parameters involved, which can affect the system performance in an unpredictable way. Therefore, the proposed algorithms to calculate the mutual information and the capacity give a valuable tool for the MIMO system design and pave the way to parameter optimization in the complex distributed MIMO environment.

The performance of multi-antenna Amplify-and-Forward (AF) relays for a future cellular system where the destination and the source form a MIMO system analyzed by two scenarios, 1st the multi-relay scenario i.e. distributed relays in which each terminal equipped with multiple antenna. 2nd one-relay scenario i.e. a single relay in a sector where each relay is equipped with at least one antenna. The optimal filter coefficients applied at the relays are

derived and recommended for both cases by M. **Qingyu et al.** [23]. The throughput of the single link showing the AF relay matched filter based performs best in the multi-relay scenario. On other hand the relay based singular value decomposition (SVD) is more suitable for the one-relay scenario.

The practical scenario for multiuser multi-hop multiple-input multiple-output (MIMO) relay systems with correlated MIMO fading channels considered where the channel fading is fast and thus the instantaneous channel state information (CSI) is only available at the destination node, but unknown at all users and all relay nodes.

Y. Rong et al. [24] derive the structure of the optimal user pre-coding matrix and relay amplifying matrix that maximizes the user's destination mutual information. The optimal structure of user pre-coding matrix and relay amplifying matrix has been proposed to optimize the mutual information of multiuser multihop MIMO relay system. The proposed power loading algorithm only has a small performance degradation compared with the optimal user and relay design using the instantaneous CSI, but greatly reduced computational complexity and signaling overhead.

Gregory G. Raleigh et.al [25] state *that* Multipath signal propagation has long been viewed as impairment to reliable communication in wireless channels. They show that the presence of multipath greatly improves achievable data rate if the appropriate communication structure is employed. A compact model is developed for the multiple-input multiple-output (MIMO) dispersive spatially selective wireless communication channel. The multivariate information capacity is analyzed. For high signal-to-noise ratio (SNR) conditions, the MIMO channel can exhibit a capacity slope in bits per decibel of power increase that is proportional to the minimum of the number multipath components, the number of input antennas, or the number of output antennas. This desirable result is contrasted with the lower capacity slope of the well-studied case with multiple antennas at only one side of the radio link.

Recent years, cooperative technology has taken a lot of attention since it can improve the bit error rate (BER) and lower the transmit power in radio mobile networks, especially when the direct channel between the source and the destination is poor. Cooperative multiple input multiple outputs (Co-MIMO) is a kind of MIMO technique, where the multiple inputs and outputs are formed via cooperation proposed by **Trungtan Nguyen et al.** [26] they show that different terminals can reduce antenna spatial correlation, thereby increase the capacity and

throughput of the system, and even reach the ideal capacity of MIMO system. Meanwhile, the number of multi-path Rayleigh fading does not affect the channel capacity.

Chao-Kai et al. [27] they study the capacity-achieving input covariance matrices for the jointly-correlated Rician fading multiple-input multiple-output (MIMO) antenna channel when perfect channel state information (CSI) is known at the receiver while only statistical CSI at the transmitter is available. Their contribution includes the expression for the asymptotic mutual information for the jointly-correlated Rician fading MIMO channel in the large-system regime in which the numbers of antennas at the transmitter and receiver go to infinity with a fixed ratio. Based on this expression, an efficient algorithm is proposed to get the capacity-achieving input covariance matrix.

An asymptotic method to derive the ergodic capacity achieving covariance matrix for a multiple-input multiple-output (MIMO) channel is presented by **Giorgio Taricco et al [28]** The method is applicable to MIMO channels affected by separately correlated Rician fading and co-channel interference. They assumed that the number of transmit, receive and interfering antennas grows asymptotically while their ratios, as well as the SNR and the SIR, approach finite constants.

Constantin Siriteanu et al [29] study the zero-forcing (ZF) detection for multiple-input multiple-output (MIMO) wireless communications systems and transmit-correlated and estimated Rician fading with realistic azimuth spread (AS) and K -factor.

The generalized Minimum Mean Squared Error (GMMSE) detector has a bit error rate performance, which is similar to the MMSE detector. The advantage of the GMMSE detector is, that it does not require the knowledge of the noise power. However, the computational complexity of the GMMSE detector is significantly higher than the computational complexity of the MMSE detector investigated by **Tharwat Morsy et al [30]**

Xiwu Lv et al. [31] they mainly focus on the information theoretic capacity of multiple-input multiple-output (MIMO) independent and identically distributed (i.i.d.) Rayleigh flat fading channels assuming equal power allocation to each of the transmit antennas. They present an overview of the analytical results on MIMO channel capacity in recent years, including the statistical properties, approximate distributions and lower and upper bounds of ergodic capacity and so on.

Zhongliang Fan *et. al.* [32]proposes a low complexity multi-input multi-output (MIMO) detector for coded systems based on the combination of maximal ratio combining (MRC) and minimum mean square error (MMSE) algorithm. The proposed scheme takes advantage of MMSE for the first iteration to guarantee reliable soft information derived from channel decoder. With these soft information and interference cancellation (IC), the MIMO system is converted to a single-input multi-output (SIMO) system. Hence, MRC, which is a simple space signal processing technology only for SIMO systems, is used in rest iterations to avoid matrix inverse associated with MMSE-based detector. Because only linear operations are required in rest iterations,

2.1 Objectives of Thesis

Primary objectives of this thesis are:

- ❖ To study and simulate the MIMO (8X8) System Capacity and Bit Error Rate.
- ❖ To study and analysis the performance of capacity gain of MIMO (8x8) in correlation Rician channel.
- ❖ To study and analyze the performance of capacity gain of MIMO (8X8) system in correlation Rayleigh channel.

CHAPTER 3

MIMO System

3.1 MIMO SYSTEM BASIC

Multiple antennas can be used at the transmitter and receiver, an arrangement called a MIMO system. A MIMO system takes advantage of the spatial diversity that is obtained by spatially separated antennas in a dense multipath scattering environment. MIMO systems may be gain to combat signal fading or to obtain a capacity gain. Generally, there are three categories of MIMO technique the first aims to improve the power efficiency by maximizing spatial diversity. Such techniques include delay diversity, STBC, and STTC. The second class uses a layered approach to increase capacity. One popular example of such a system is V-Blast., Where full spatial diversity is usually not achieved. Finally, the third type exploits the knowledge of channel at the transmitter. It decomposes the channel coefficient matrix using SVD.

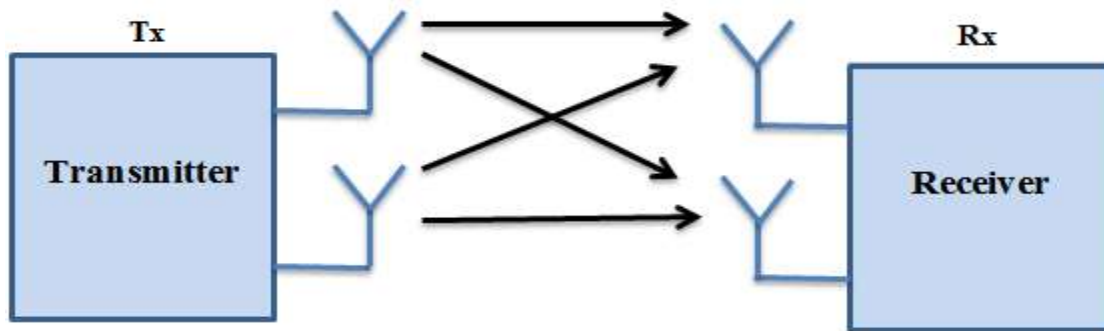

Figure 8: MIMO System

3.2 MIMO System

We have consider a MIMO system with transmit array of N_t antenna and receive array of N_r antenna as shown in figure 8 . The transmitted matrix is $N_t \times 1$ column matrix X where X_i is i th component which is transmitted from i th antenna. We suppose the channel is Gaussian channel and elements of channel are supposed to independent identically distributed (i.i.d) Gaussian variables. If channel is unknown at the transmitter side we assume that equal power E_X/N_t is given to each transmitter antenna. The covariance of transmitted matrix is given by

$$R_{xx} = \frac{E_X}{N_t} I_{N_t} \quad (3.1)$$

Where E_X is the power across transmitter irrespective number of antennas where I_{N_t} is a $N_t \times N_t$ identity matrix.

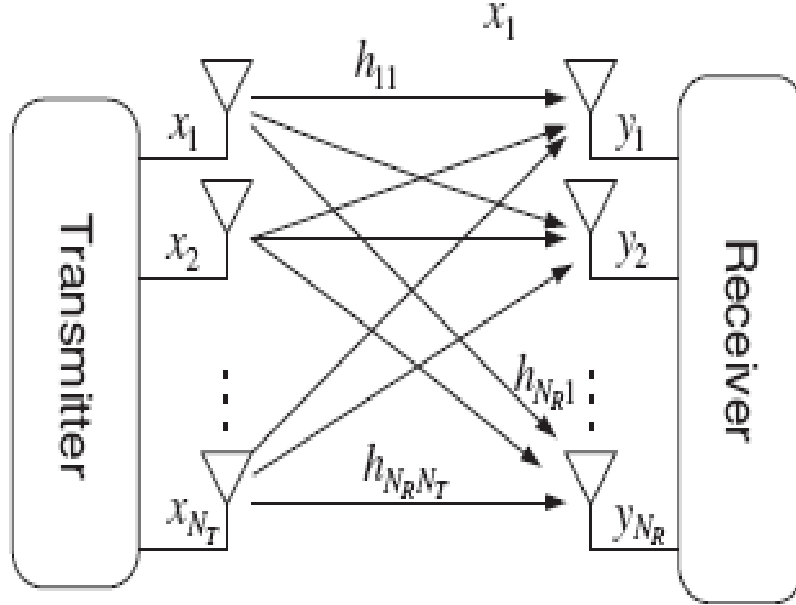

Figure 9 MIMO Model

The channel matrix H is a $N_t \times N_r$ complex matrix. The component $h_{i,j}$ of the matrix is the fading coefficient from j th transmit antenna to i th receive antenna. If we assume that received power of each antenna is equal to total transmitted power E_X . This means we ignore the signal attenuation, antenna gain and other things, for a deterministic channel as

$$\sum_{j=1}^{N_t} |h_{i,j}|^2 = N_t \quad i = 1, 2, 3, \dots, N_r \quad (3.2)$$

If we assume that channel matrix is known at only receiver side not at transmitter side. The channel matrix at receiver can be estimated by training sequence. If transmitter to know this channel we can communicate this information to transmitter via feedback channel. Noise at the receiver is another column of size $N_r \times 1$, denoted by n . The components of n are zero mean circularly symmetrical complex Gaussian (ZMCSCG) variable. The covariance matrix of receiver noise given by

$$R_{nn} = E\{nn^H\} \quad (3.3)$$

If there is not any correlation between component of n then

$$R_{nn} = N_o I_{N_r} \quad (3.4)$$

each of the N_r receive branches has identical noise power N_o . Since we have assumed the total received power per antenna is equal to total transmitted power. The SNR can be written as

$$\gamma = \frac{E_x}{N_t} \quad (3.5)$$

there for receiver vector can express as

$$R = HX + n \quad (3.6)$$

3.3 MIMO Transmission

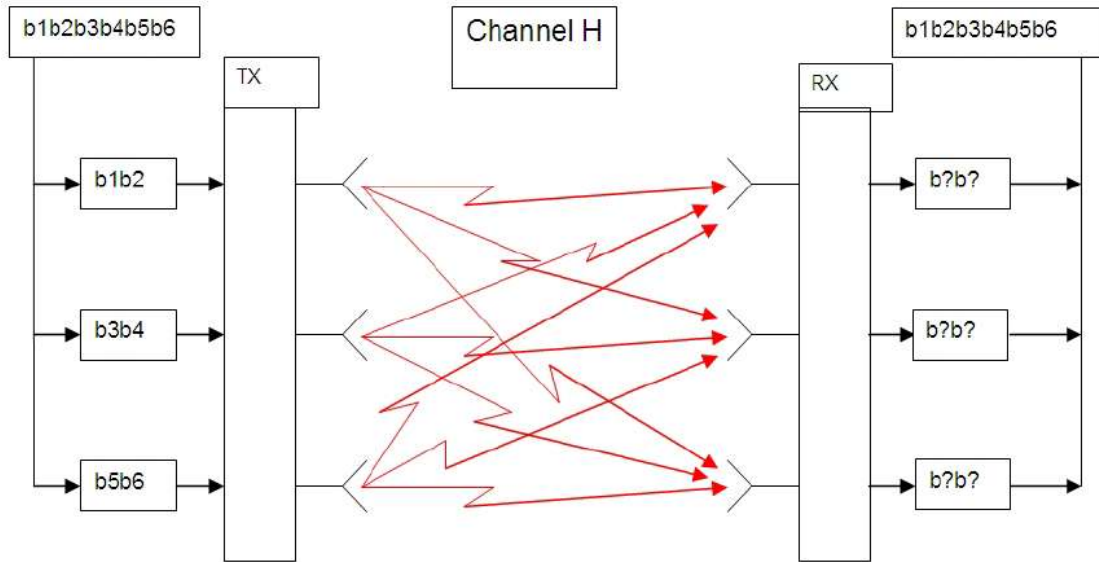

Figure 10 : Data transmission in MIMO system

We focus on a single-user communication model and consider a point-to-point link where The transmitter is equipped with N_T antennas and the receiver employs N_r antennas. Next to the single user assumption in the depiction as point-to-point link, we suppose that no inter-symbol interference (ISI) occurs. This implies that the bandwidth of the transmitted signal is very small and can be assumed frequency flat (narrowband assumption), so that each signal path can be represented by a complex-valued gain factor. For practical purposes, it is common to model the channel as frequency-flat whenever the bandwidth of the system is smaller than the inverse of the delay spread of the channel; hence a wideband system

operating where the delay spread is fairly small may sometimes be considered as frequency flat. The figure shown below demonstrates how data is transmitted in a MIMO system. Consider the 6-bit data stream shown in figure-10. This data stream is broken down (demultiplexed) into N equal rate data streams, where N is the number of transmitting antennas, which is three in this case. Each of the lower bit rate sub streams are transmitted from one of the antennas. All are transmitted at the same time and at the same frequency, therefore they mix together in the channel. Since all sub streams are being transmitted at the same frequency, it is very spectrally efficient.

Each of the receive antennas picks up all of the transmitted signals superimposed upon one another. If the channel 'H' is a sufficiently rich scattering environment, each of the superimposed signals will have propagated over slightly different paths and hence will have differing spatial signatures. The spatial signatures exist due to the spatial diversity at both ends of the link, and therefore create independent propagation channels. Each transmit receive antenna pair can be treated as parallel sub channels (i.e. a single-input single-output (SISO) channel), this will become clearer when discuss the analysis of the channel H. Since the data is being transmitted over parallel channels, one channel for each antenna pair, the channel capacity increases in proportion to the number of transmitter-receiver pairs.

3.4 Small scale fading

Coherence bandwidth Range of frequencies over which the channel can be considered flat (i.e. channel passes all spectral components with equal gain and linear phase). Two sinusoids with frequency separation greater than B_c are affected quite differently by the channel. If we define Coherence Bandwidth (B_C) as the range of frequencies over which the frequency correlation is above 0.9. Doppler shift Measure of spectral broadening caused by motion We know how to compute Doppler shift: f_d Doppler spread, B_D , is defined as the maximum Doppler shift: $f_m = v/\lambda$. If the baseband signal bandwidth is much greater than B_D then effect of Doppler spread is negligible at the receiver. Coherence time is the time duration over which the channel impulse response is essentially invariant. If the symbol period of the baseband signal (reciprocal of the baseband signal bandwidth) is greater the coherence time, than the signal will distort, since channel will change during the transmission of the signal. When the waves of multipath signals are out of phase, reduction in signal strength or fade

can occur. The type of fading experienced by a signal propagating through a mobile radio channel depends on the nature of the transmitted signal with respect to the characteristics of the channel. Depending on the relation between the signal parameters (such as bandwidth, symbol period, etc.) and the channel parameters (such as rms delay spread and Doppler spread), different transmitted signals will undergo different types of fading. Fade zones tend to be small, multiple areas of space within a multipath environment that cause periodic attenuation of a received signal for users passing through them. In other words, the received signal strength will fluctuate downward, causing a momentary, but periodic, degradation in quality. The small-scale signal fading due to the time dispersion and frequency dispersion mechanisms in a mobile channel could be classified into four major categories depending on the nature of the transmitted signal, the channel and the mobile velocity.

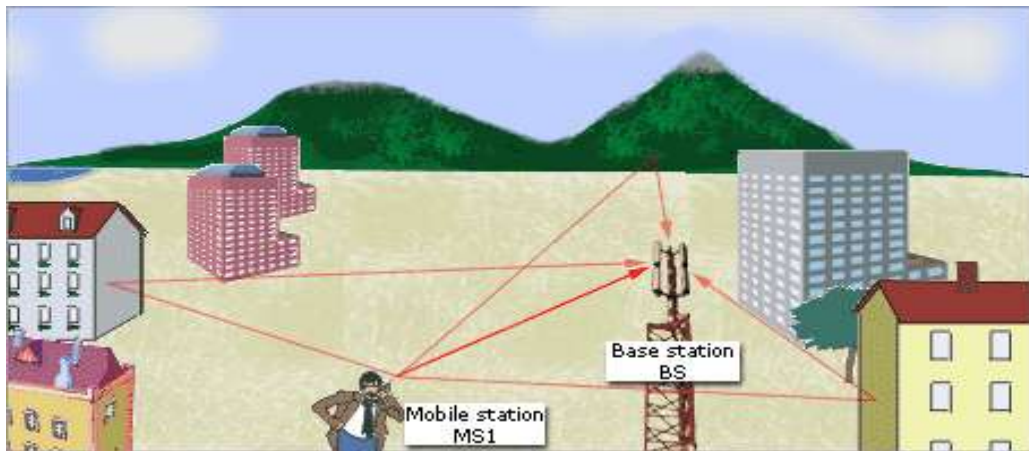

Figure 11 : Multipath propagation of a signal

3.4.1 Fast Fading

In a fast fading channel, the channel impulse response changes rapidly within the symbol duration [1]. That is, the coherence time of the channel is smaller than the symbol period of the transmitted signal. This causes frequency dispersion due to Doppler spreading, which leads to signal distortion. Fast fading channel only deals with the rate of change of the channel due to motion. In practice, fast fading only occurs for very low data rates.

3.4.2 Slow Fading

In a slow fading channel, the channel impulse response changes at a much slower rate than the transmitted baseband signal [1]. The channel may be assumed to be static over on or

several reciprocal bandwidth intervals. In the frequency domain, this implies that the Doppler spread of the channel is much less than the bandwidth of the baseband signals.

3.4.3 Frequency Selective Fading

The channel creates frequency selective fading on the received signal if the channel possesses a constant-gain and linear phase response over a bandwidth that is smaller than the bandwidth of transmitted signal [1]. Under such conditions, the channel response has a multipath delay spread which is greater than the reciprocal bandwidth of the transmitted message waveform. When this occurs, the received signal includes multiple versions of the transmitted waveform, which are attenuated and delayed in time, and hence the received signal is distorted. When viewed in frequency domain, certain frequency components in the received signal spectrum have greater gains than others. The spectrum of the transmitted signal, for frequency selective fading, has a bandwidth greater than the coherence bandwidth of the channel.

Frequency selective fading channel models are very difficult to model since each multipath must be modeled and the channel must be considered to be a linear filter. Therefore, these models are typically developed from the wideband multipath measurements. However, when analyzing mobile communication systems, statistical impulse response models such as the two-ray Rayleigh fading model are generally used. In two-ray Rayleigh fading model, the consideration is that the impulse response of the channel is made up of two delta functions that fade independently and have sufficient time delay between them to induce frequency selective fading upon the applied signal [33].

3.4.4 Flat Fading

The received signal will undergo flat fading channel if the mobile radio channel has a constant gain and linear phase response over a bandwidth, which is greater than the bandwidth of the transmitted signal [1]. The multipath structure of the channel is such that the spectral characteristics of the transmitted signal are preserved at the receiver but the strength of the received signal changes with time due to fluctuations in the gain of the channel caused by multipath. Flat fading channels are also known as narrowband channels since the bandwidth of the applied signal is narrow as compared to the channel flat fading

bandwidth. Typical flat fading causes deep fades and thus required a higher transmitter power of 20 or 30 dB to achieve low bit error rates during times of deep fades.

3.5 Diversity Techniques

Diversity is a powerful communication receiver technique that provides wireless link improvement at relatively low cost. Unlike equalization, diversity requires no training overhead since the transmitter does not require a training sequence. Furthermore, there are wide ranges of diversity implementations, many of which are very practical and provide significant link improvement with little added cost. Diversity exploits the random nature of radio propagation by finding independent signal paths for communication. In virtually all applications, diversity decisions are made by the receiver, and are unknown to the transmitter. The diversity concept can be explained simply. If one radio path undergoes a deep fade, another independent path may have a strong signal. By having more than one path to select from, both the instantaneous and average SNRs at the receiver may be improved.

3.6 Types of Diversity

In this section, we examine the type of diversity that can be used to provide the inputs to the diversity combiner. Most diversity systems are implemented in the receiver instead of the transmitter since no extra transmitter power is needed to implement the receiver diversity system. Since the path between the mobile and base is assumed to be reciprocal, diversity systems implemented in a mobile will work similarly to those in a base station. There are two general types of diversity schemes [7].

3.6.1 Macroscopic diversity scheme

The Macroscopic diversity scheme is used for combining two or more long-term lognormal signals, which are obtained via independently fading paths received from two or more different antennas at different base-station sites. The local mean strength varies because of variations of terrain between the mobile transmitter and the base station receiver. If only one antenna site is used, the traveling mobile unit may not be able to transmit a signal to the base station at certain geographical locations because of terrain variations such as hills or mountains. Therefore, two separated antenna sites can be used to receive two signals and to combine them to reduce long-term fading. The selective combining technique is

recommended in the macroscopic diversity scheme since other methods require coherent combining that is difficult to achieve when the receivers are some distance apart. Macroscopic diversity is often used in short-wave systems to reduce the effects of fading from the ionosphere. Cellular and PCS system achieve the same effect by handoffs to nearby cell sites when the signal strength becomes weak [34].

3.6.2 Microscopic diversity scheme

The Microscopic diversity scheme is used for combining two or more short-term Rayleigh signals, which are obtained via independently fading paths received from two or more different antennas but only at one receiving co site. Once the diversity branches are created, any of the combining methods can be used. In mobile wireless communications, multipath fading can cause constructive and destructive interference. A popular method to mitigate the effects of multipath fading is diversity, a process of obtaining multiple independent signal branches through many dimensions including time, frequency, polarization, angle, and space

Time Diversity

Time diversity reception techniques are primarily applicable to the transmission of digital data over a fading channel [2]. In time diversity, the same data are sent over the channel at time intervals of the order of the reciprocal of the baseband fade rate $f_b = 2f_m$. In mobile radio, the reciprocal fade rate can be expressed:

$$\tau \approx \frac{1}{2f_m} = \frac{1}{2\left(\frac{v}{\lambda}\right)}$$

The time separation increases as the fade rate decreases. Multiple diversity channels can be provided by successively transmitting the signal sample in each time slot. The sampling rate for voice transmission of a single channel is $(2 \times 4 \text{ kHz} = 8 \text{ kHz})$ [35]. For M branch diversity, the sampling rate must be $(M \times 8 \text{ kHz})$, since the transmission delay spread is usually less than 20ms, which is much less than the inverse of the sampling rate:

$$f_s < \frac{1}{\Delta}$$

Hence, the sampling rate f_s is not limited by the time-delay spread. However, the minimum time separation between samples shown in for diversity application may cause a serious problem, since f_m is a Doppler frequency, expressed:

$$f_m = \frac{v}{\lambda}$$

When the vehicle is stationary, $v=0$, and thus $f_m=0$. This means that the time separation μ_s is infinite. Therefore, the advantages of time diversity are lost when the vehicle is not moving. This is in sharp contrast to other diversity schemes, in which the branch separation is not a function of vehicle speed and thus the two diversity signals are independent over any value of v .

Frequency Diversity

Frequency diversity is implemented by transmitting information on more than one carrier frequency. The rationale behind this technique is that frequencies separated by more than the coherence bandwidth of the channel will be uncorrelated and will thus not experience the same fades [2]. Theoretically, if the channels are uncorrelated, the probability of simultaneous fading will be product of the individual fading probabilities [36].

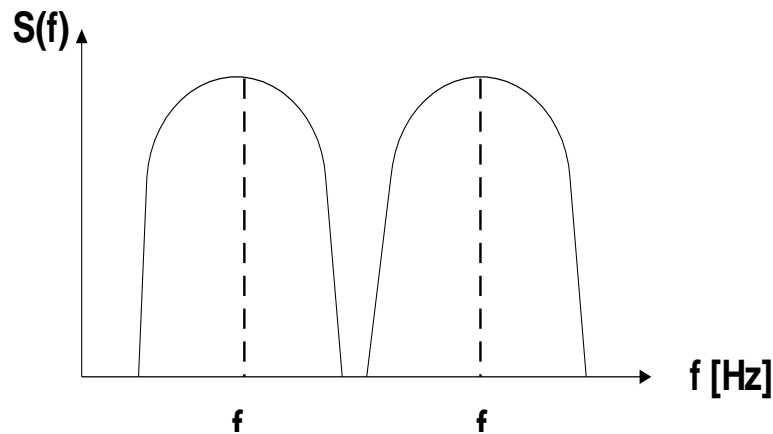

Figure 12 : Frequency Diversity

Frequency diversity is often employed in microwave line-of-sight links, which carry several channels in a frequency division multiplex mode (FDM). Due to troposphere propagation and resulting refraction, deep fading sometimes occurs. In practice, 1: N protection switching is provided by a radio licensee, wherein one frequency is nominally idle but is available on a stand-by basis to provide frequency diversity switching for any one of the N other carriers (frequencies) being used on the same link, each carrying independent traffic. When diversity is needed, the appropriate traffic is simply switched to the backup frequency. This technique

has the disadvantage that it not only requires spare bandwidth but also requires that there be as many receivers as there are channels used for the frequency diversity.

Polarization Diversity

Signals transmitted in either horizontal or vertical electric fields are uncorrelated at both the mobile and Base station receivers. The horizontal and vertical polarization components, E_x and E_y , transmitted by two polarized antennas at the base station and received by two polarized antennas at the mobile unit, can provide two uncorrelated fading signals. Polarization diversity results in a 3-dB power reduction at the transmitting site since the power must be split into two different polarized antennas. The de-correlation for the signals in each polarization is caused by multiple reflections in the channel between the mobile and base station. After sufficient random reflections, the polarization state of the signal will be independent of the transmitted polarization. In practice, however, there is some dependence of the received of the received polarization on the transmitted polarization [34].

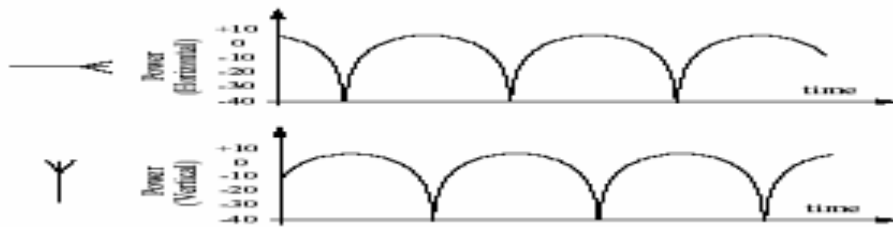

Figure 13: Polarization Diversity

Angle Diversity

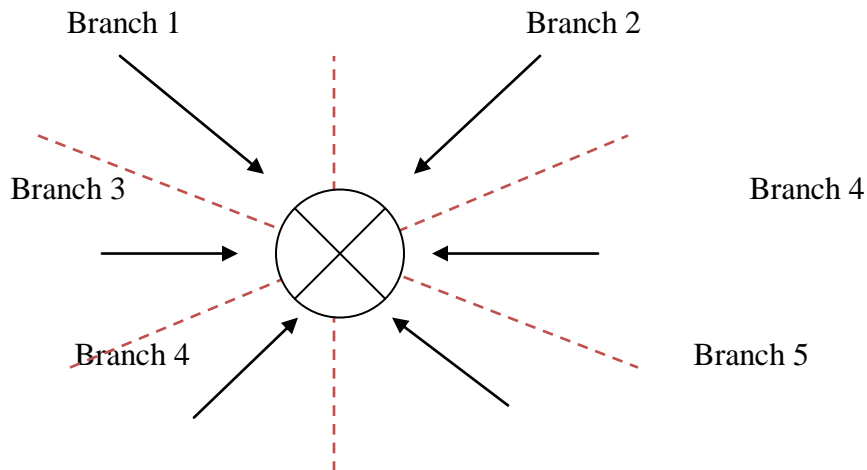

Figure 14: Angle Diversity

When the operating frequency is greater than 10 GHz, the scattering of the signals from transmitter to receiver generates received signals from different directions that are uncorrelated with each other. Thus, two or more directional antennas can be pointed in different directions at the receiving site and provide signals for a combiner. This scheme is more effective at the mobile unit than at the base station since the scattering is from local buildings and vegetation and is more pronounced at street level than at the height of base station antenna.

Space diversity

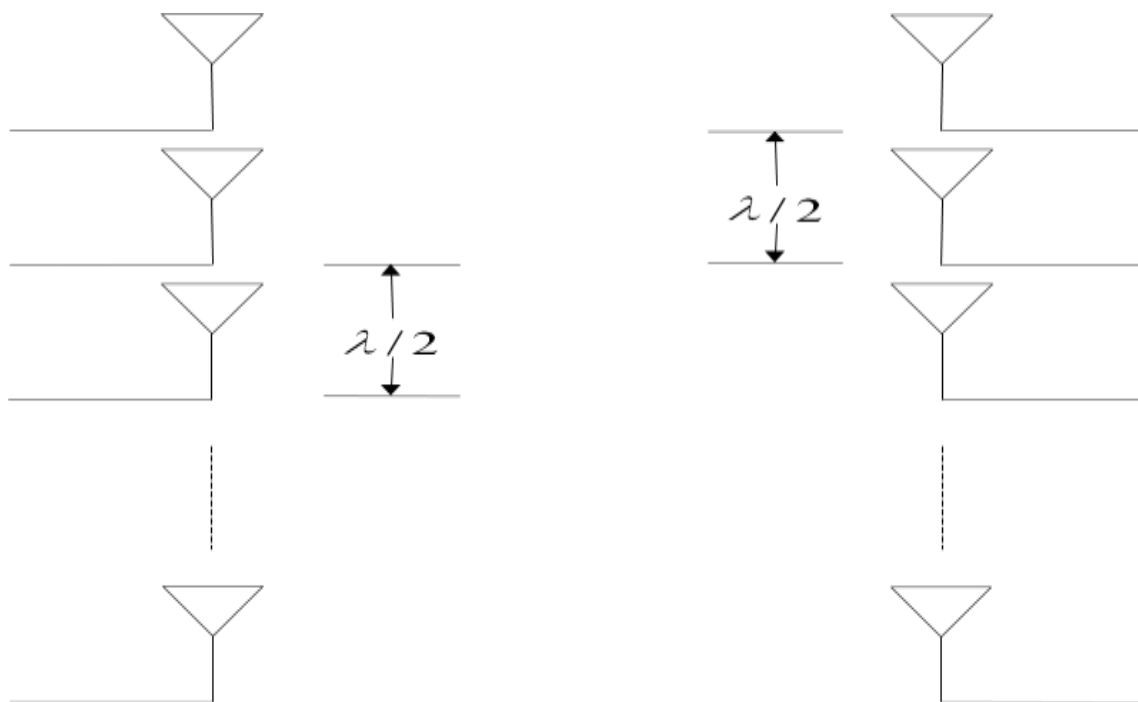

Figure 15: Space Diversity

Redundancy is provided by employing an array of antennas, with a minimum separation of $\lambda/2$ between neighbouring antennas. Differently polarized antennas can also be used. But it is not practical to have a mobile with multiple antennas separated by $\lambda/2$ (7.5 cm apart at 2 GHz). Can have multiple receiving antennas at base stations, but must be separated on the order of ten wavelengths (1 to 5 meters). Since reflections occur near receiver, independent signals spread out a lot before they reach the base station. A typical antenna configuration for

120 degree sectoring can be used in space diversity For each sector, a transmit antenna is in the center, with two diversity receiving antennas on each side. If one radio path undergoes a deep fade, another independent path may have a strong signal. By having more than one path one select from, both the instantaneous and average SNRs at the receiver may be improved

3.7 MIMO Diversity Techniques

The key idea in MIMO diversity techniques is that the same data stream is transmitted from multiple antennas or received at more than one antenna. MIMO diversity schemes are impressively effective in increasing the diversity gain where consequently performance is improved [37]. Diversity can be implemented at the transmit end (transmit diversity), at the receive end (receive diversity) or at both ends of the wireless link. Generally, MIMO diversity techniques can provide higher SNR and improve transmission reliability as a result.

3.7.1 Transmit Diversity

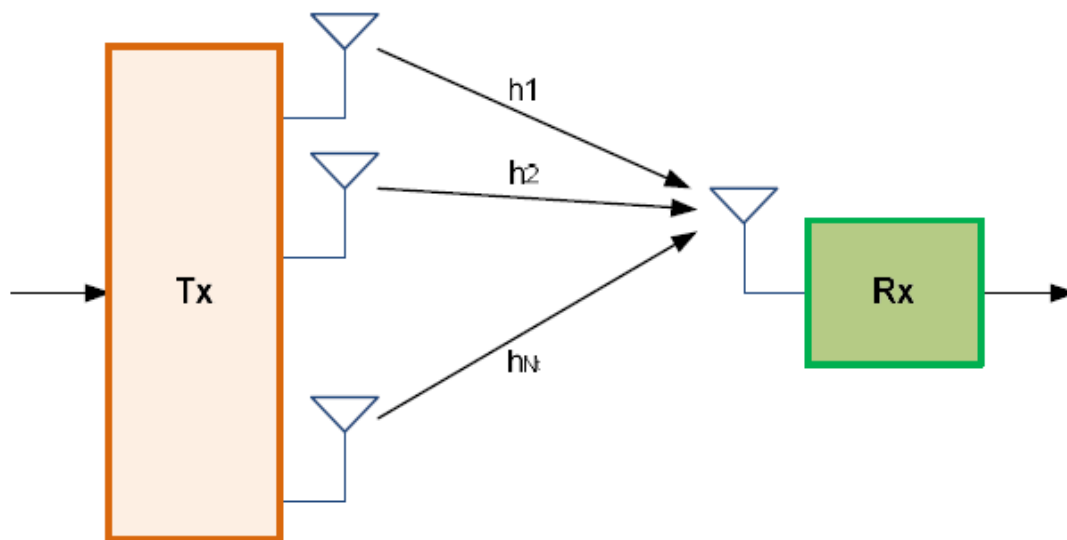

Figure 16 : Transmit Diversity

Transmit diversity improves the signal quality and achieves a higher SNR ratio at the receiver side; it involves transmitting data stream through multiple antennas and receiving by single antenna or more. Transmit diversity can effectively mitigate multipath fading effects as multiple antennas afford a receiver several observations of the same data stream. Each antenna will experience a different interference environment and if one antenna experienced

a deep fade, then it is likely that another has a sufficient signal. Thus, transmit diversity can help improve the reliability of the data reception and data decoding as well. The most popular examples of these transmit diversity techniques include Alamouti code [38] and orthogonal j codes proposed by Taroukh et al. [39]. Figure 16 depicts the whole system for an exemplary N_t transmit antenna system.

3.7.2 Receive Diversity

Receive diversity are widely used in wireless communication systems; it can be achieved by receiving redundant copies of the same signal. The idea behind receive diversity is that each antenna at the receive end can observe an independent copy of the same signal. Therefore the probability that all signals are in deep fade simultaneously is significantly reduced. This type of diversity hasn't particular settings or requirements on the transmit end, but requires a receiver that could simultaneously process all received signals and combines them by a proper combining method [37]. There are several classical methods for combining the different diversity branches at the receiver [40], [41], the most important of which and most widely used are Selection Combining (SC), Maximal Ratio Combining (MRC) and Equal Gain Combining (EGC).

Selection Combining

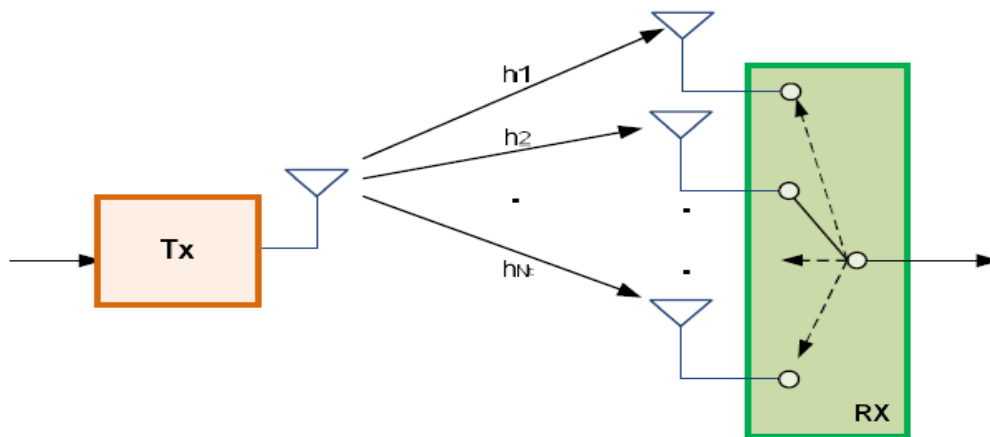

Figure 17: Receive Diversity: Selection Combining

Selection combining shown in Figure 17 is the simplest form of receive diversity combining methods. Fundamentally it estimates the instantaneous SNR for each of the received signals and selects the particular receiver output with the strongest SNR among N_r diversity

branches; where N_t is the number of receive antennas in the system. Selection Diversity is simple and cheap. In this receiver selects branch with highest instantaneous SNR. New selection made at a time that is the reciprocal of the fading rate. This will cause the system to stay with the current signal until it is likely the signal has faded. In selection diversity there is improvement in SNR. Let $\bar{\gamma}$ is new average signal SNR. Γ : avg. SNR in each branch.

$$\text{Then } \bar{\gamma} = \Gamma \sum_{k=1}^m \frac{1}{k} = \Gamma \left(1 + \frac{1}{2} + \frac{1}{3} + \frac{1}{4} + \dots + \frac{1}{m} \right) > \Gamma$$

Maximal Ratio Combining

The selection combining technique ignores information from all diversity branches except the particular branch that has the highest SNR. This drawback is mitigated by using Maximal Ratio Combining, in which the information from all branches is combined in order to maximize the output SNR [9]. MRC works by weighting each branch with the complex conjugate of their particular channel coefficients and then do summation to produce the received signal as shown in Figure 18. The voltage signals from each of the M diversity branches are co-phased to provide coherent voltage addition and are individually weighted to Provide optimal SNR. The resulting signal envelop applied to detector:

$$r_m = \sum_{l=1}^M G_l r$$

Total noise Power

$$N_T = N \sum_{l=1}^M G_l^2$$

SNR applied to detector

$$\gamma_m = \frac{r_m^2}{2N_t}$$

The voltage signals from each of the M diversity branches are co-phased to provide coherent voltage addition and are individually weighted to provide optimal SNR. The voltage signals from each of the M diversity branches are co-phased to provide coherent voltage addition and are individually weighted to provide optimal SNR. The SNR out of the diversity combiner is the sum of the SNRs in each branch.

$$\gamma_m = \frac{1}{2} \frac{\sum \left(\frac{r_i^2}{N}\right)^2}{\sum \left(\frac{r_i^2}{N}\right)} = \frac{1}{2} \sum_{i=1}^M \frac{r_i^2}{N} = \sum_{l=1}^M \gamma_l$$

The probability that γ_m less than some specific SNR threshold γ

$$P(\gamma_m) = \frac{\gamma_m^{M-1} e^{-\frac{\gamma_m}{\Gamma}}}{\Gamma^M (M-1)!} \quad \gamma_m \geq 0$$

$$P(\gamma_m \leq \gamma) = \int_0^\gamma P(\gamma_m) d\gamma_m$$

MRC gives optimal SNR improvement:

Γ_i : avg. SNR of each individual branch

$\Gamma_i = \Gamma$ if the avg. SNR is the same for each branch

$$\bar{\gamma}_m = M \Gamma$$

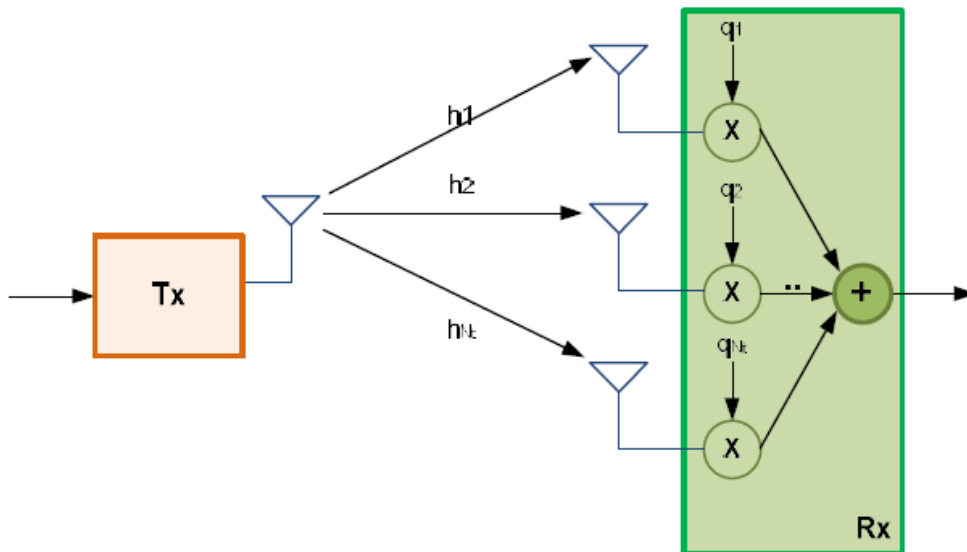

Figure 18: Receive Diversity: maximal ratio combining

Equal Gain Combining (EGC) is similar to Maximal Ratio Combining without weighting the signals before summation [19]. In EGC co-phasing is needed to avoid signal cancellation. The average SNR improvement of EGC is typically about 1 dB worse than with MRC, but still simpler to implement than MRC.

3.8 MIMO Spatial Multiplexing Techniques

Spatial Multiplexing (SM) has been utilized in MIMO systems to provide higher transmission rate without allocating additional bandwidth or increasing the transmit power [44]. The VBLAST [43] was the practical implementation approach of spatial multiplexing technique. Spatial multiplexing involves deploying multiple antennas at both transmitter and receiver ends as shown in Figure 19. Input data streams can be divided into different independent sub streams and then transmitted simultaneously via sufficiently-separated antennas ($\lambda / 2$) or more, to obtain highly uncorrelated and independent signal). It has been shown in [2] that utilizing spatial multiplexing schemes under certain conditions and assumptions, can linearly increases capacity with relation to the minimum of the number of transmit antennas and the number of receive antennas.

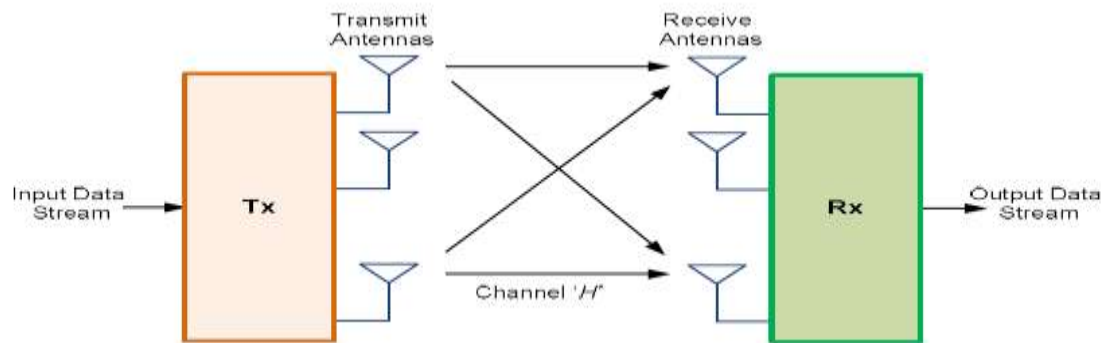

Figure 19 Spatial Multiplexing System

3.9 Advantages of MIMO Systems

The increased demand on higher transmission rate for the cutting edge wireless applications makes MIMO technology very important for the future wireless communication systems. MIMO systems can provide different advantages over single input single out output conventional system [37]. MIMO systems exploit multiple antennas diversity at transmitter/receiver. This gives the possibility to increase system reliability by one of the transmit diversity techniques in which the same signal is transmitted through multiple antennas. Different copies of the signal can be observed at the receiver and the probability that at least one of the copies is not experiencing a deep fade increases. Thus the receiver can successfully recover the signal with decreased bit/symbol error rate and overall system performance is improved as well. MIMO systems can proportionally increase the achievable

data-rates by spatial multiplexing, i.e. transmitting multiple independent data streams within the allocated bandwidth. Thereafter, the receiver can separate/recover the data streams under certain channel conditions such as a rich scattering surrounding wireless channel. MIMO systems can produce different gains such as array gain, diversity gain and multiplexing gain. Despite the fact that these gains compete each other, they may combined to increase the coverage area and to reduce the required transmit power [37]. Assume that there are N_r receive antennas and only one transmit antenna, then the average SNR is approximately $N_r \gamma$, then it can be found that the coverage area is increased by a multiplicative factor γ , where γ is the average SNR per branch. This can be used to increase the coverage area for a fixed transmitted power, or it can be used to reduce the transmitted power requirement for a given coverage area. The most benefit behind using MIMO technology is that all above advantages are achieved without requiring any additional bandwidth for the wireless system. Moreover, the offered benefits can help meet the challenges posed by both the impairments in the wireless channel as well as resource constraints and limitations. Therefore, MIMO technology constitutes a breakthrough in a wireless communication system design.

Chapter 4

Capacity and BER Analysis

4.1 Introduction

We have consider a MIMO system with transmit array of N_t antenna and receive array of N_r antenna as shown in figure 20. The transmitted matrix is $N_t \times 1$ column matrix X where X_i is i th component which is transmitted from i th antenna. We suppose the channel is Gaussian channel and elements of channel are supposed to independent identically distributed (i.i.d) Gaussian variables. If channel is unknown at the transmitter side we assume that equal power E_X/N_t is given to each transmitter antenna. The covariance of transmitted matrix is given by

$$R_{xx} = \frac{E_X}{N_t} I_{N_t}$$

Where E_X is the power across transmitter irrespective number of antennas where I_{N_t} is an $N_t \times N_t$ identity matrix. If channel is unknown at the transmitter side we assume [2] that equal power E_X/N_t is given to each transmitter antenna.

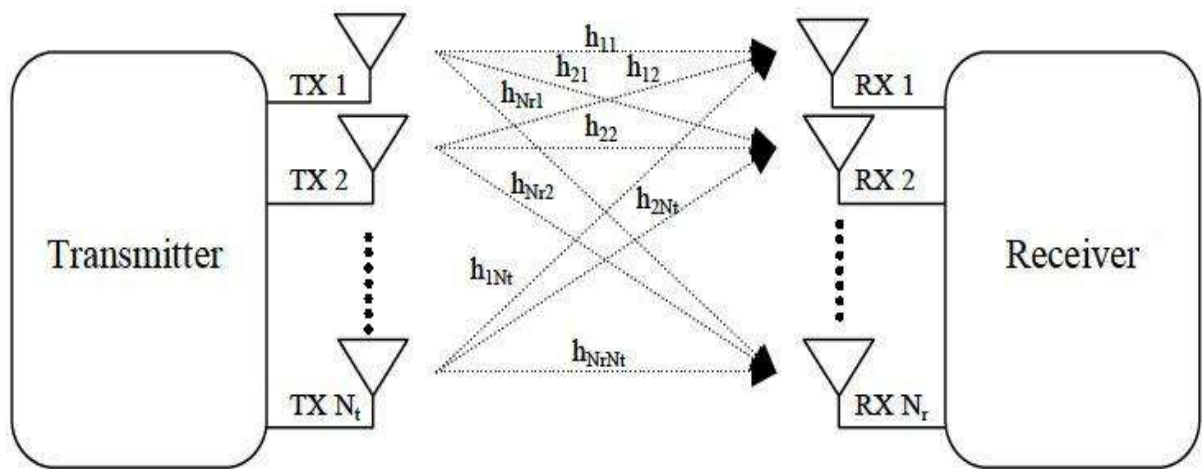

Figure 20: MIMO Rayleigh Channel Model

The channel matrix H is a $N_t \times N_r$ complex matrix. The component $h_{i,j}$ of the matrix is the fading coefficient from j th transmit antenna to i th receive antenna. If we assume that received

power of each. Antenna is equal to total transmitted power E_x . This mean we ignore the signal attenuation, antenna gain and other things, for a deterministic channel as

$$\sum_{j=1}^{N_t} |h_{i,j}|^2 = N_t \quad i = 1,2,3 \dots \dots N_t \quad (4.1)$$

If we assume that channel matrix is known at only receiver side not at transmitter side. The channel matrix at receiver can be estimated by training sequence. If transmitter to know this channel we can communicate this information to transmitter via feedback channel. Noise at the receiver is another column of size $N_r \times 1$, denoted by n . The components of n are zero mean circularly symmetrical complex Gaussian (ZMCSCG) variable. The covariance matrix of receiver noise given by

$$R_{nn} = E\{nn^H\} \quad (4.2)$$

If there is not any correlation between component of n then

$$R_{nn} = N_o I_{N_r} \quad (4.3)$$

each of the N_r receive branches has identical noise power N_o . Since we have assumed the total power received power per antenna is equal to total transmitted power. The SNR can be written as

$$\gamma = \frac{E_x}{N_t} \quad (4.4)$$

There for receiver vector can express as

$$R = Hx + n \quad (4.5)$$

4.2 Deterministic MIMO Channel Capacity

For two random vector x and y the mutual information is defined as

$$I(x,y) = H(y) - H(y|x) \quad (4.6)$$

Where $H(y|x)$ the conditional entropy.

$$H(x/y) = -E[\log_2(p(x|y))] \quad (4.7)$$

For a linear complex model

$$Y = Hx + n \quad (4.8)$$

Where x has zero mean and n is ZMCSCG vector with covariance matrix $\sigma_n^2 I$. Thus y has zero mean and covariance matrix

$$HPH^H + \sigma_n^2 I \quad (4.9)$$

The mutual information is given as

$$I(y,x|H) = \log_2 \det \left(I + \frac{1}{\sigma_n^2} H P H^H \right) \quad (4.10)$$

The Shannon capacity is the maximum mutual information between received vector and transmitted vector

$$C(H) = B \det \left(I + \frac{1}{\sigma_n^2} H P H^H \right) \quad (4.11)$$

When full transmitter CSI and receiver CSI are available, the capacity of the MIMO system is maximum.

4.2.1 CSI is Not Available At Transmitter for Channel Capacity Calculation

When receiver knows what is the channel state information and transmitter has no any idea about channel state information. Then we have to assign equal power to each transmitted antenna. In this case R_{xx} is an identity matrix.

$$\begin{aligned} C &= \log_2 \left[\det \left(I_{N_r} + \frac{\bar{\gamma}}{N_t} H H^H \right) \right] \\ &= \sum_{i=1}^{r_H} \log_2 \left(1 + \frac{\bar{\gamma}}{N_t} \beta_i \right) \end{aligned} \quad (4.12)$$

Where r_H is called the rank of matrix and r_H is $\min(N_t, N_r)$. So the capacity of the MIMO channel is expressed as the sum of r_H SISO channel, each have gain β_i .

CASE 1

$$\begin{aligned} \text{SIMO } N_t = 1 \text{ and } N_r > 1 \text{ then } \beta &= N_r \\ C(\text{SIMO}) &= \log_2(1 + \bar{\gamma} N_r) > C(\text{AWGN}) \end{aligned} \quad (4.13)$$

The knowledge of CSI at transmitter does not affect the SIMO channel. So capacity of SIMO is greater than C(AWGN)

CASE 2

$$\begin{aligned} \text{MISO } N_t > 1 \text{ and } N_r = 1 \text{ then } \beta &= N_t \\ C(\text{MISO}) &= \log_2(1 + \bar{\gamma}) = C(\text{AWGN}) \end{aligned} \quad (4.14)$$

Capacity of SIMO is greater than MISO system because MISO does not take the advantages of antenna array gain since it has no CSI.

CASE 3

MIMO MISO $N_t > 1$ and $N_r > 1$

$$\begin{aligned} \frac{1}{N_t} H H^H &\rightarrow N_r I_{N_r} \\ C &= N_r \log_2(1 + \bar{\gamma}) = N_r C(\text{AWGN}) \end{aligned} \quad (4.15)$$

So the capacity is N_r times the $C(AWGN)$.

4.2.2 Transmitter Knows the CSI for Capacity Analysis

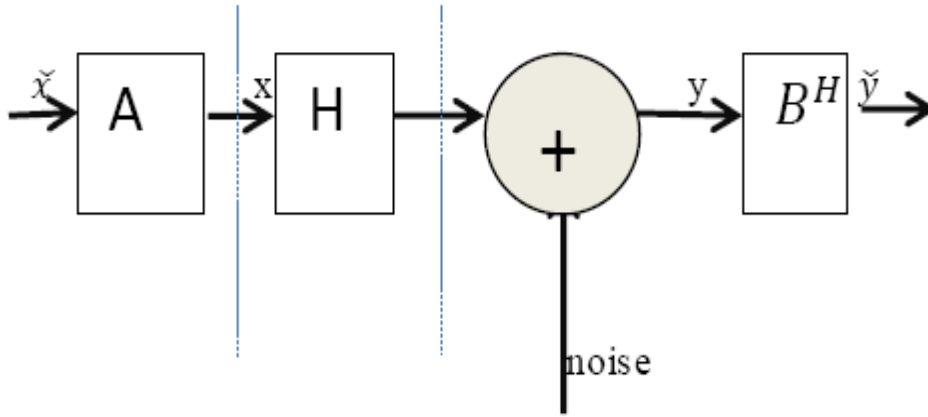

Figure 21: Transmitter know the CSI

The channel H is decomposed using SVD (single value decomposition) as shown in figure 21, in which transmitted signal is preprocessed with A and received signal is post processed with B^H .

Transmitted signal is preprocessed with A and received signal is post processed with B^H .

$$\begin{aligned} \text{At transmitter} \quad x &= A\tilde{x} \\ \text{At receiver} \quad \tilde{y} &= B^H y \end{aligned} \quad (4.16)$$

In this way MIMO channel is decomposed into r_H parallel (figure 22) channels.

$$\tilde{y}_i = \sqrt{\frac{E_x}{N_t}} \sqrt{\beta_i} \quad i=1,2,\dots,r_H \quad (4.17)$$

The maximum capacity can be obtained by maximizing the sum of individual capacity

$$C = \max \sum_{i=1}^{r_H} \log_2 \left(1 + \frac{\tilde{y}_i}{N_t} E_i \beta_i \right) \quad (4.18)$$

$$\sum_{i=1}^{r_H} E_i = N_t \quad (4.19)$$

$$E_i = \left(\frac{\epsilon N_t}{E_x} - \frac{N_t}{\tilde{y}_i \beta_i} \right)$$

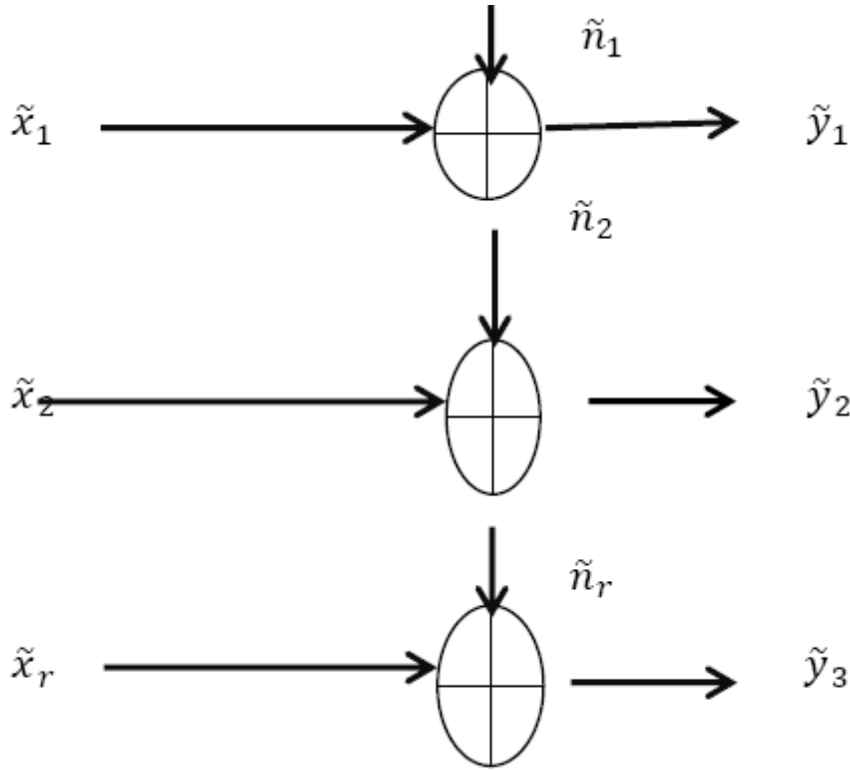

Figure 22: r virtual SISO channels obtained from model decomposition of MIMO channel

The optimal power given is estimated by iteration. In each iteration, the constant ϵ is obtained. Then power which is given to every mode is calculated. If power allocated to node is negative, the mode is dropped and power given to another node is calculated.

4.2.3 Channel Capacity With and Without CSI

We can expect higher capacity obtain when transmitter know the channel state information. There is another parameter SNR come in to the picture which play important factor during power calculation.

CASE 1 $N_t > N_r$ SNR $\longrightarrow \infty$

Method Water filling

$$\frac{C_{\text{CSI}}}{C_{\text{NO-CSI}}} \longrightarrow 1$$

Incremental Gain

$$G = \max \left[N_r \log_2 \left(\frac{N_t}{N_r} \right), 0 \right] \quad (4.20)$$

So gain increases linearly with N_r but it is optimistic at low SNR.

CASE 2 $N_t > 1, N_r = 1$ SNR = Low Value

$$\frac{C_{\text{CSI}}}{C_{\text{NO-CSI}}} = N_t$$

$$(N_t, N_r \rightarrow \infty)$$

$$\frac{C_{\text{CSI}}}{C_{\text{NO-CSI}}} \rightarrow \left(1 + \sqrt{\frac{N_t}{N_r}}\right)^2 > 1 \quad (4.21)$$

4.2.4 EFFECT of Correlation on MIMO

Correlation define the relationship between signal and delayed signal. There are two type of correlation auto correlation and cross correlation. MIMO channel capacity has been reduced due to correlation between transmit and receive antenna. We are taking a MIMO system in which channel gains between transmitter and receiver are correlated. The deterministic channel capacity can be written as

$$C = \max_{\text{Tr}(R_{xx})=N} \log_2 \det(R_{xx}) + \log_2 \det\left(\frac{E_x}{NN_0} H_w H_w^H\right)$$

$$\text{When } R_{xx} = I_N \quad (4.22)$$

Then capacity will become maximum.

We are taking correlated channel model

$$H = R_r^{1/2} H_w R_t^{1/2} \quad (4.23)$$

Here R_t is the correlation between the column vectors H. R_r is the correlation between the row vector oh H. The diagonal entries of R_t and R_r are forced to unity.

$$C = \log_2 \det\left(I_{N_r} + \frac{E_x}{N_t N_0} H H^H\right) \quad (4.24)$$

Put the value of H (equation 4.23) in (4.24)

$$C = \log_2 \det\left(N_t + \frac{E_x}{N_t N_0} R_r^{1/2} H_w R_t H_w^H R_r^{1/2}\right)$$

$$C = \log_2 \det\left(N_t + \frac{E_x}{N_t N_0} R_r^{1/2} H_w R_t H_w^H R_r^{1/2}\right) \quad (4.25)$$

If $N_t = N_r = N$ and R_t, R_r of full rank Then c becomes

$$C = \log_2 \det \left(\frac{E_x}{N_t N_0} H_W H_W^H \right) + \log_2 \det (R_r) + \log_2 \det (R_r) \quad (4.26)$$

4.2.5 Ergodic Capacity

In previous topic we have assumed that MIMO channels are deterministic. In general, however, MIMO channels change randomly. Therefore, H is a random matrix, which means that its channel capacity is also randomly time-varying. In other words, the MIMO channel capacity can be given by its time average. In practice, we assume that the random channel is an ergodic process. Then, we should consider the following statistical notion of the MIMO channel capacity:

$$\begin{aligned} \tilde{C} &= E_H [C(H)] \\ \tilde{C} &= E \left\{ \max_{R_{xx}} \log_2 \det \left(I_{N_r} + \frac{E_{xx}}{N_t N_0} H R_{xx} H^H \right) \right\} \end{aligned} \quad (4.27)$$

This is frequently known as an ergodic channel capacity. For example, the ergodic channel Capacity for the open-loop system without using CSI at the transmitter side, from Equation

$$\overline{C_{OL}} = E \sum_{i=1}^r \log_2 \left(1 + \frac{E_x}{N_T N_0} \right) \quad (4.28)$$

Similarly, the ergodic channel capacity for the closed-loop (CL) system using CSI at the Transmitter side, from Equation (9.24), is given a

$$\overline{C_{CL}} = E \sum_{i=1}^r \log_2 \left(1 + \frac{E_x}{N_T N_0} \lambda_i \lambda_i^{opt} \right) \quad (4.29)$$

4.3 Relay MIMO Network

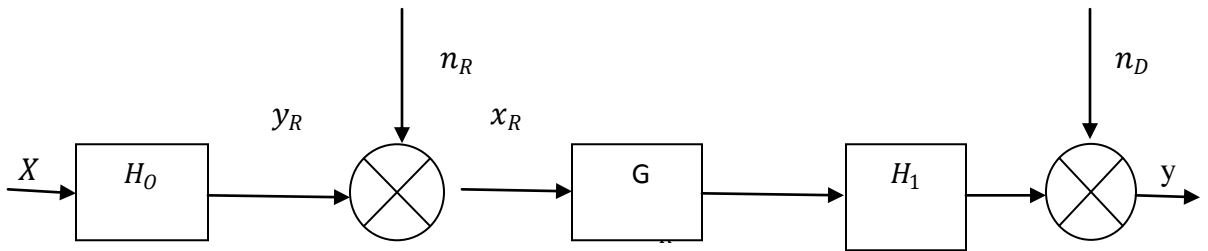

Figure 23: RELAY MIMO

Wireless relaying networks have recently been given considerable attention due to their many advantages. Apart from increasing the range, relaying networks can also achieve better diversity by using cooperative transmission from the source and several relays [45]. The

block diagram of MIMO AF relay system is shown in Figure. 23 .The relaying terminals forward the information from the source to the destination mainly using the well-known method AF since MIMO systems can provide better system capacity than SISO, SIMO and MISO systems, relaying has recently been extended to MIMO scenarios. MIMO relays aim to provide improved system capacity, increases in range, and better diversity as traditional communication system. The ergodic capacity of an AF MIMO two-hop system under Rayleigh fading channel is analyzed. Amplifying-Forward (AF) MIMO relay channel consists of source, relay and destination terminal each having multiple antennas. Relay terminal employs an amplifying matrix. Large network have shown increase in ergodic capacity by using large random matrix theory . The upper bound and lower bound on Capacity of fading relay for correlated channel is demonstrated in [46]. The scaling of capacity for relay channel is $N/2 \log K$ with single source and destination. In this thesis work the two-hop MIMO relay channel is considered having a source, a relay and a destination terminal equipped with N_s, N_r, N_d and numbers of antennas. The whole process of transmission is implemented in two phases. In first phase source terminal transmit a vector signal to relay, this is single hop and in second phase relay terminal transmit the received vector signal after modifying the parameter to destination terminal that is second hop.. First phase channel matrix is represented by $H_0 \in \mathbb{C}^{N_r \times N_s}$ and the second phase channel matrix represented by $H_1 \in \mathbb{C}^{N_d \times N_r}$ the .and the forward matrix of relay channel represented by $G \in \mathbb{C}^{N_r \times N_r}$.The received signal at the Relay terminal (Y_0) and destination terminal (Y_1) is given by

$$\begin{aligned} Y_0 &= H_0 X + n_0 \\ Y_1 &= H_1 G Y_0 + n_1 \end{aligned} \quad (4.30)$$

$G = \sqrt{\frac{\beta}{n}}$ is forward matrix where β overall power gain of relay channel that depend on the distance and path loss between source and relay terminal.

$$H_1 = R_t^{\frac{1}{2}} W_l T_t^{\frac{1}{2}} \quad (4.31)$$

Where W_l denote the channel matrix with i.i.d complex Gaussian random entries. $R_i \in \mathbb{C}^{N \times N}$ and $T_i \in \mathbb{C}^{N \times N}$ the receiver and transmitter spatial correlation matrix. If H_1 is perfectly known at the destination terminal then the mutual information between X and Y will be given by

$$I(X, Y) = \log \left(\det \left(I + \frac{\beta_i}{n_i} H_1 H_1^H + \frac{\beta_s}{n_s} H_1 H_2 H_1^H + H_2^H \right) \right) - \log \left(\det \left(I + \frac{\beta_i}{n_i} H_1 H_1^H \right) \right) \quad (4.32)$$

4.4 Beam Forming

Beamforming increase the system gain at the receive side by making signals emitted from different antennas add up constructively [6], and to reduce the multipath fading effect. A MIMO system with N_t transmitter antennas and N_R receiver antennas, including beamforming vectors and combining vectors. Assume that MIMO system is narrow bandwidth and block fading, discrete-time equivalent channel is modeled as $N_t \times N_R$ matrix H , then the relation of space time block coding between input and output can be expressed as

$$Y = Hx + n \quad (4.33)$$

And the relation of beamforming between input and output can be

$$y = z^H H m x + z^H n \quad (4.34)$$

Here x is the transmitted symbol signal, m is the $N_t \times 1$ complex beamforming vector and z is the $N_R \times 1$ receiver combining vector, which is the function of the channel information, i.e., m ,

$$z = f(H). (\cdot)^H \quad (4.35)$$

The main motive is to how the design m and z to maximize the signal to noise ratio, which can reduce the bit error rate and increase the capacity. The MIMO beamforming technique is a scheme that maximizes the instantaneous output SNR by jointly choosing optimum transmitting weight vector m and receiving combining vector z .

$$\text{SNR}[47] = \frac{E|SS^H|}{\|z^H\|^2 \sigma^2} = \frac{\|z^H m H\|^2}{\|z^H\|^2} n \quad (4.36)$$

where $\|\cdot\|$ is the Frobenius norm of a matrix, which is the sum of the norms of all the matrix elements. n is the SNR at the receiver for a SISO channel. $E|SS^H| = E_s$ is the maximum total power transmitted on T antennas at one symbol time. Therefore, maximizing the SNR at the receiver is equivalent to maximizing $\frac{\|z^H m H\|^2}{\|z^H\|^2} n$.

For a beamforming system, the capacity of a given channel realization can be given as [48]

$$C_{\text{bf}} = \max_{m: m^H m = p} \left[\log \left(1 + \frac{\|z^H m H\|^2}{\|z^H\|^2 \sigma_n^2} \right) \right] \quad (4.37)$$

In the case of space time coding effective channel capacity given as

$$C_s = \frac{K}{L} \log \left(1 + \frac{n}{T} \|H\|^2 \right) \quad (4.38)$$

4.5 Outage Capacity

Capacity with the outage allows bits sent over a given transmission burst to be decoded at the end of burst with some probability that these bits will be decoded incorrectly[49]. The transmitter fixes minimum received SNR m and encodes a data for $C = B \log(1 + m_{min})$. Data is properly received if received SNR is greater than m_{min} . If received SNR value is less than m then there is probability that burst cannot be decoded properly approaches 1. Thus receiver declares as outage. The probability of outage is

$$\begin{aligned} P_{out} &= p(m < m_{min}) \\ C_{out} &= (1 - P_{out}) B \log(1 + m_{min}) \end{aligned} \quad (4.39)$$

In the case of Rayleigh channel

$$\begin{aligned} P(m_i) &= \frac{1}{\bar{m}} e^{-\frac{m_i}{\bar{m}}} \\ P_{OUT}(m_0) &= 1 - e^{-\frac{m_0}{\bar{m}}} \end{aligned} \quad (4.40)$$

4.6 Rician Channel

The MIMO channel capacity has been studied for the Rayleigh scenario. On the other hand, in reality, MIMO channels do not always satisfy the i.i.d Rayleigh fading condition. In reality, there is often a line-of-sight (LOS) path between the transmitter and the receiver, and in such fading conditions, the channel is represented by the Rician fading model. There is random channel matrix in a MIMO Rician fading channel is a complex Gaussian matrix with a non- zero mean matrix, in a Rayleigh-faded MIMO channel there the channel matrix is of zero mean. The Rayleigh fading model can be seen as a special case of the Rician fading model. In which mean is set to zero. Consider a single user MIMO system with N_t transmit antennas and N_r receiver antennas. For simplicity we consider only frequency flat fading; i.e., the fading is not frequency selective. The transmitted signal in each symbol period is represented by a $N_t \times 1$ column matrix s , where i th component s_i refers to the transmitted signal from antenna i . The channel matrix H is a $N_t \times N_r$ complex matrix. The component $h_{i,j}$ of the matrix is the fading coefficient from j th transmit antenna to i th receive. The additive white Gaussian noise at the receiver is described by $N_r \times N_t$ column matrix n . Thus, the system is described by the matrix equation [50],

$$y = \sqrt{\frac{E_s}{N_t}} Hs + n \quad (4.41)$$

In Rician fading the elements of H are non-zero mean complex Gaussians. Hence we can Express H in matrix notation as [12]

$$H = aH^{SP} + bH^{sc} \quad (4.42)$$

Where the specular [48] and scattered components of H are denoted by superscripts, $a > 0$, $b > 0$ and $a^2 + b^2 = 1$.

H^{SP} is a matrix of unit entries denoted by H_1 .

If there is no correlation at the transmitter or at the receiver side then the entries of H^{sc} are independent usually denoted by $H\omega$.

- If there is correlated fading then the H^{sc} matrix can be modeled as
- $H^{sc} = R_r^{1/2} H_w R_t^{1/2}$ (4.43)
- Where R_t and R_r are the correlation matrix at the transmitter and at the receiver side respectively.
- The correlation matrix R is defined[10]

$$r_{ij} = \begin{cases} r^{i-j} & i \leq j \\ r^*_{j-i} & i > j \end{cases} \quad (4.44)$$

$$H(\text{correlated})[20] = \sqrt{\frac{K}{K+1}} H_1 + \sqrt{\frac{1}{K+1}} R_r^{1/2} \quad (4.45)$$

- If value of $k = 0$ then it acts as Rayleigh channel .
- If value of K (RICIAN FACTOR) increases then capacity (MIMO) decrease .
- If value of K (RICIAN FACTOR) increases then capacity (SIMO) increase.

4.7 Equalization (detection) Techniques

During the past few years, there has been an explosion in wireless technology. This growth has opened a new dimension to future wireless communications whose ultimate goal is to provide universal personal and multimedia communication without regard to mobility or location with high data rates. To achieve such an objective, the next generation personal communication networks will need to be support a wide range of services which will include high quality voice, data, facsimile, still pictures and streaming video. These future services are likely to include applications which require high transmission rates of several Mega bits

per seconds (Mbps). The data rate and spectrum efficiency of wireless mobile communications have been significantly improved over the last decade or so. Recently, the advanced systems such as 3GPP LTE and terrestrial digital TV broadcasting have been sophisticatedly developed using OFDM and CDMA technology. In general, most mobile communication systems transmit bits of information in the radio space to the receiver. The radio channels in mobile radio systems are usually multipath fading channels, which cause inter-symbol interference (ISI) in the received signal. To remove ISI from the signal, there is a need of strong detector which requires knowledge on the channel impulse response. Equalization (detection) techniques which can combat and/or exploit the frequency selectivity of the wireless channel are of enormous importance in the design of high data rate wireless systems. Although such techniques have been studied for over 40 years, recent developments in signal processing, coding and wireless communications suggest the need for paradigm shifts in this area. On one hand, the demonstrated efficiency of soft-input soft-output signal processing algorithms and iterative (turbo) techniques have fuelled interest in the design and development of nearly optimal joint detection and decoding techniques. On the other hand, the popularity of MIMO communication channels, rapidly time varying channels due to high mobility, multi-user channels, multi-carrier based systems and the availability of partial or no channel state information at the transmitter and/or receiver bring new problems which require novel detection techniques. Hence, there is a need for the development of novel practical, low complexity detection techniques and for understanding their potentials and limitations when used in wireless communication systems characterized by very high data rates, high mobility and the presence of multiple antennas [51]. In radio channels, a variety of adaptive detection can be used to cancel interference while providing diversity. Since the mobile fading channel is random and time varying, detector must track the time varying characteristics of the mobile channel, and thus are called adaptive detector. The general operating modes of an adaptive detector include training and tracking. First, a known, fixed-length training sequence is sent by the transmitter so that the receiver's detector may adapt to a proper setting for minimum bit error rate (BER) detection. The training sequence is typically a pseudorandom binary signal or a fixed, prescribed bit pattern. Immediately following this training sequence, the user data (which may or may not include coding bits) is sent and the adaptive detector at the receiver utilizes a recursive algorithm to

evaluate the channel and estimate filter coefficients to compensate for the distortion created by multipath in the channel. The training sequence is designed to permit a detector at the receiver to acquire the proper filter coefficients in the worst possible channel conditions (e.g., fastest velocity, longest time delay spread, deepest fades, etc.) so that when the training sequence is finished, the filter coefficients are near the optimal values for reception of user data. As user data are received, the adaptive algorithm of the detector tracks the changing channel. As a consequence, the adaptive detector is continually changing its filter characteristics over time. When a detector has been properly trained, it is said to have converged. The time span over which a detector converges is a function of the detector algorithm, the detector structure, and the time rate of change of the multipath radio channel [52].

4.7.1 Types of MIMO Equalizer

Some special detection techniques have been proposed in the literature in order to exploit the high spectral capacity offered by MIMO systems. These techniques are grouped into three main categories: linear, nonlinear, and tree-search.

In our present thesis discussion point of view we have studied three types of commonly used detectors used in MIMO systems. These detectors' names are given below:

1. Zero Forcing (ZF) Detectors
2. Minimum Mean Square Error (MMSE) Detector
6. Maximum Likelihood (ML) Detector.

8x8 MIMO System

Let's take a 8 transmit 8 receive antenna case (resulting in a 8x8 MIMO channel). We will assume that the channel is a flat fading Rayleigh multipath channel and the modulation is BPSK.

8x8 MIMO channel

In a 8x8 MIMO channel, probable usage of the available 8 transmit antennas can be as follows:

1. Consider that we have a transmission sequence, for example $\{x_1, x_2, x_3, \dots, x_n\}$.
2. In normal transmission, we will be sending x_1 in the first time slot, x_2 in the second time slot, x_3 and so on.

3. However, as we now have 8 transmit antennas, we may group the symbols into groups of eight. In the first time slot, send $x_1, x_2, x_3, x_4, x_5, x_6, x_7, x_8$ from the first and second, third, fourth, fifth, sixth, seventh, eighth antenna. In second time slot, $x_9, x_{10}, x_{11}, x_{12}, x_{13}, x_{14}, x_{15}, x_{16}$ the first and second, third, fourth, fifth, sixth, seventh, eighth antenna.

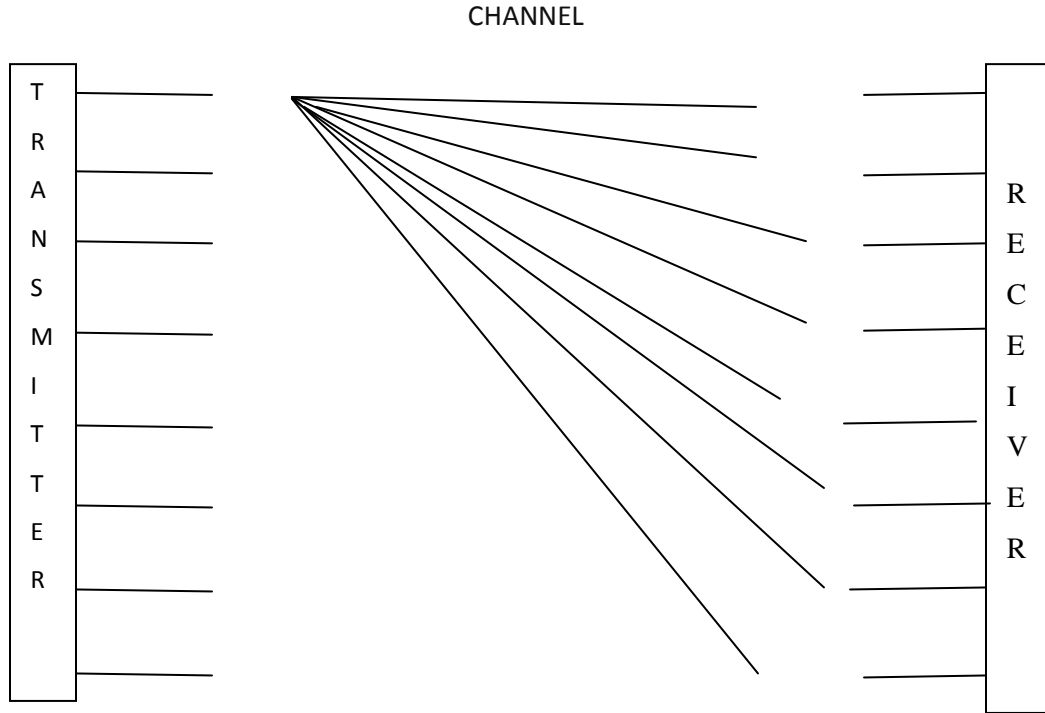

Figure 24 : MIMO (8X8)

4. Notice that as we are grouping eight symbols and sending them in one time slot.
5. This forms the simple explanation of a probable MIMO transmission scheme with 8 Transmit antennas and 8 receive antennas.

$$y_1 = h_{1,1}x_1 + h_{1,2}x_2 + h_{1,3}x_3 + h_{1,4}x_4 + h_{1,5}x_5 + h_{1,6}x_6 + h_{1,7}x_7 + h_{1,8}x_8 + n_1$$

$$= [h_{1,1} \quad h_{1,2} \quad h_{1,3} \quad h_{1,4} \quad h_{1,5} \quad h_{1,6} \quad h_{1,7} \quad h_{1,8}] \begin{bmatrix} x_1 \\ x_2 \\ x_3 \\ x_4 \\ x_5 \\ x_6 \\ x_7 \\ x_8 \end{bmatrix} + n_1$$

$x_1, x_2, x_3, x_4, x_5, x_6, x_7, x_8$ are the transmitted symbols and n_1, n_2, n_3, n_4 is the noise on 1st, 2nd, 3rd, 4th receive antennas. We assume that receiver knows $h_{1,1}, h_{1,2}, h_{1,3}, h_{1,4}, h_{2,1}, h_{2,2}, h_{2,3}, h_{2,4}, h_{3,1}, h_{3,2}, h_{3,3}, h_{3,4}, h_{4,1}, h_{4,2}, h_{4,3}, h_{4,4}$. The receiver also knows y_1, y_2, y_3 and y_4 . The unknown are x_1, x_2, x_3 and x_4 . For convenience, the above equation can be represented in matrix notation as follows:

$$\begin{bmatrix} y_1 \\ y_2 \\ y_3 \\ y_4 \\ y_5 \\ y_6 \\ y_7 \\ y_8 \end{bmatrix} = \begin{bmatrix} h_{1,1} & h_{1,2} & h_{1,3} & h_{1,4} & h_{1,5} & h_{1,6} & h_{1,7} & h_{1,8} \\ h_{2,1} & h_{2,2} & h_{2,3} & h_{2,4} & h_{2,5} & h_{2,6} & h_{2,7} & h_{2,8} \\ h_{3,1} & h_{3,2} & h_{3,3} & h_{3,4} & h_{3,5} & h_{3,6} & h_{3,7} & h_{3,8} \\ h_{4,1} & h_{4,2} & h_{4,1} & h_{4,4} & h_{4,5} & h_{4,6} & h_{4,7} & h_{4,8} \\ h_{5,1} & h_{5,2} & h_{5,1} & h_{5,4} & h_{5,5} & h_{5,6} & h_{5,7} & h_{5,8} \\ h_{6,1} & h_{6,2} & h_{6,1} & h_{6,4} & h_{6,5} & h_{6,6} & h_{6,7} & h_{6,8} \\ h_{7,1} & h_{7,2} & h_{7,1} & h_{7,4} & h_{7,5} & h_{7,6} & h_{7,7} & h_{7,8} \\ h_{8,1} & h_{8,2} & h_{8,1} & h_{8,4} & h_{8,5} & h_{8,6} & h_{8,7} & h_{8,8} \end{bmatrix} \begin{bmatrix} x_1 \\ x_2 \\ x_3 \\ x_4 \\ x_5 \\ x_6 \\ x_7 \\ x_8 \end{bmatrix} + \begin{bmatrix} n_1 \\ n_2 \\ n_3 \\ n_4 \\ n_5 \\ n_6 \\ n_7 \\ n_8 \end{bmatrix}$$

Equivalently, $y=Hx+n$

We can follow the same process for 8x8 MIMO system.

Different Detection Techniques Mathematical Explanation

Considering the above stated system model different MIMO detectors with mathematical explanation are explained below one by one.

Zero Forcing (ZF) Detector

The ZF is a linear estimation technique, which inverse the frequency response of received signal. The inverse is taken for the restoration of signal after the channel. The estimation of strongest transmitted signal is obtained by nulling out the weaker transmitted signal. The strongest signal is then subtracted from received signal and proceeded to decode strong signal from the remaining transmitted signals [23]. ZF equalizer ignores the additive noise and may significantly amplify noise for channel. The major advantages of ZF linear equalizer is that it simply eliminates ISI by forcing the overall pulse, which is the convolution of the channel and the equalizer to make a unit-impulse response. Although the noise power and covariance function does not need to be estimated in ZF even than its perform poor than that of ML [24],[25]. For a channel with frequency response $C(f)$ the zero forcing equalizer $E(f)$ is constructed by combining the equalizer and channel which gives a flat frequency and linear phase if and only if $C(F)xE(f)$ The channel response is $H(s)$ then the input signal is

multiplied by the reciprocal of $H(s)$. The zero forcing approach tries to find a matrix W which satisfies $WH=I$. The Zero Forcing (ZF) linear detector for meeting this constraint is given by,

$$W = (H^H H)^{-1} H^H .$$

This matrix is also known as the pseudo inverse [25] for a general $m \times n$ matrix. Note that the off diagonal terms in the matrix $H^H H$ are not zero. Because the off diagonal terms are not zero, the zero forcing detector tries to null out the interfering terms when performing the detection, i.e. when solving for x_1 the interference from x_2 is tried to be nulled and vice versa. While doing so, there can be amplification of noise. Hence Zero Forcing detector is not the best possible detector to do the job. However, it is simple and reasonably easy to implement [53].

Minimum Mean Square Error (MMSE) Detector

Minimum mean square error equalizer minimizes the mean –square error between the outputs of the equalizer and the transmitted symbol, which is a stochastic gradient algorithm with low complexity. Unlike a ZF equalizer, an MMSE equalizer maximizes the signal–to–distortion ratio by penalizing both residual ISI and noise enhancement. Instead of removing ISI completely, an MMSE equalizer allows some residual ISI to minimize the overall distortion. Compared with a ZF equalizer, an MMSE equalizer is much more robust in presence of deepest channel nulls and noise. Most of the finite tap equalizer are designed to minimize the mean square error performance metric but MMSE directly minimizes the bit error rate. The channel model for MMSE is same as ZF [27],[28]. The MMSE equalization is

$$W_{MMSE} = \arg \cdot_G^{\min} E_{x,n} \| x - x^2 \|$$

The Minimum Mean Square Error (MMSE) approach tries to find a coefficient W which minimizes the criterion,

$$E\{[Wy - x][Wy - x]^H\}$$

Solving,

$$W = [H^H H + N_0 I]^{-1} H^H$$

When comparing to the equation in Zero Forcing detector, apart from the $N_0 I$ term both the

equations are comparable [54]. Infract, when the noise term is zero, the MMSE detector reduces to Zero Forcing detector.

Maximum Likelihood (ML) Detector

The Maximum Likelihood (ML) detection is a scheme well known to be very robust and well suited for practical implementation whereas linear receiver suffers from numerical complexity. ML detector is the optimal receiver in terms of bit error rate (detector performance) but it is a nonlinear detector with a high complexity.

The Maximum Likelihood [45,54] receiver tries to find $\hat{\mathbf{x}}$ which minimizes,

$$j = |\mathbf{y} - H\hat{\mathbf{x}}|^2, \text{ or}$$

$$j = \begin{bmatrix} y_1 \\ y_2 \\ y_3 \\ y_4 \\ y_5 \\ y_6 \\ y_7 \\ y_8 \end{bmatrix} - \begin{bmatrix} h_{1,1} & h_{1,2} & h_{1,3} & h_{1,4} & h_{1,5} & h_{1,6} & h_{1,7} & h_{1,8} \\ h_{2,1} & h_{2,2} & h_{2,3} & h_{2,4} & h_{2,5} & h_{2,6} & h_{2,7} & h_{2,8} \\ h_{3,1} & h_{3,2} & h_{3,3} & h_{3,4} & h_{3,5} & h_{3,6} & h_{3,7} & h_{3,8} \\ h_{4,1} & h_{4,2} & h_{4,3} & h_{4,4} & h_{4,5} & h_{4,6} & h_{4,7} & h_{4,8} \\ h_{5,1} & h_{5,2} & h_{5,3} & h_{5,4} & h_{5,5} & h_{5,6} & h_{5,7} & h_{5,8} \\ h_{6,1} & h_{6,2} & h_{6,3} & h_{6,4} & h_{6,5} & h_{6,6} & h_{6,7} & h_{6,8} \\ h_{7,1} & h_{7,2} & h_{7,3} & h_{7,4} & h_{7,5} & h_{7,6} & h_{7,7} & h_{7,8} \\ h_{8,1} & h_{8,2} & h_{8,3} & h_{8,4} & h_{8,5} & h_{8,6} & h_{8,7} & h_{8,8} \end{bmatrix} \begin{bmatrix} \hat{x}_1 \\ \hat{x}_2 \\ \hat{x}_3 \\ \hat{x}_4 \\ \hat{x}_5 \\ \hat{x}_6 \\ \hat{x}_7 \\ \hat{x}_8 \end{bmatrix}^2$$

Since the modulation is BPSK, the possible values of x_1 is +1 or -1 similarly x_2 also take values +1 or -1. So, to find the Maximum Likelihood solution, we need to find the minimum from the all sixty four combinations of $x_1, x_2, x_3, x_4, x_5, x_6, x_7, x_8$. But we are taking the example of 2x2 MIMO system. The Maximum Likelihood (ML) detection is a scheme well known to be very robust and well suited for practical implementation whereas linear receiver suffers from numerical complexity. ML detector is the optimal receiver in terms of bit error rate (detector performance) but it is a nonlinear detector with a high complexity. The ML detection is given by [22]

$$j = |\mathbf{y} - H\hat{\mathbf{x}}|^2,$$

$$j_{+1,+1} = \left| \begin{bmatrix} y_1 \\ y_2 \end{bmatrix} - \begin{bmatrix} h_{1,1} & h_{1,2} \\ h_{2,1} & h_{2,2} \end{bmatrix} \begin{bmatrix} +1 \\ +1 \end{bmatrix} \right|^2,$$

$$j_{+1,-1} = \left| \begin{bmatrix} y_1 \\ y_2 \end{bmatrix} - \begin{bmatrix} h_{1,1} & h_{1,2} \\ h_{2,1} & h_{2,2} \end{bmatrix} \begin{bmatrix} +1 \\ -1 \end{bmatrix} \right|^2,$$

$$j_{-1,+1} = \left| \begin{bmatrix} y_1 \\ y_2 \end{bmatrix} - \begin{bmatrix} h_{1,1} & h_{1,2} \\ h_{2,1} & h_{2,2} \end{bmatrix} \begin{bmatrix} -1 \\ +1 \end{bmatrix} \right|^2, \text{ and}$$

$$j_{-1,-1} = \left\| \begin{bmatrix} y_1 \\ y_2 \end{bmatrix} - \begin{bmatrix} h_{1,1} & h_{1,2} \\ h_{2,1} & h_{2,2} \end{bmatrix} \begin{bmatrix} -1 \\ -1 \end{bmatrix} \right\|^2$$

The estimate of the transmit symbol is chosen based on the minimum value from the above four values i.e.

If the minimum is $j_{+1,+1} \Rightarrow [1 \ 1]$,

If the minimum is $j_{+1,-1} \Rightarrow [1 \ 0]$,

If the minimum is $j_{-1,+1} \Rightarrow [0 \ 1]$, and

If the minimum is $j_{-1,-1} \Rightarrow [0 \ 0]$.

In the case of (8X8)MIMO the total number of cases are 64.

Chapter 5 Results

In the case of MIMO (8x8) system there are eight antenna at transmitter and receiver. MIMO (8x8) system increases the capacity and reduces the BER.

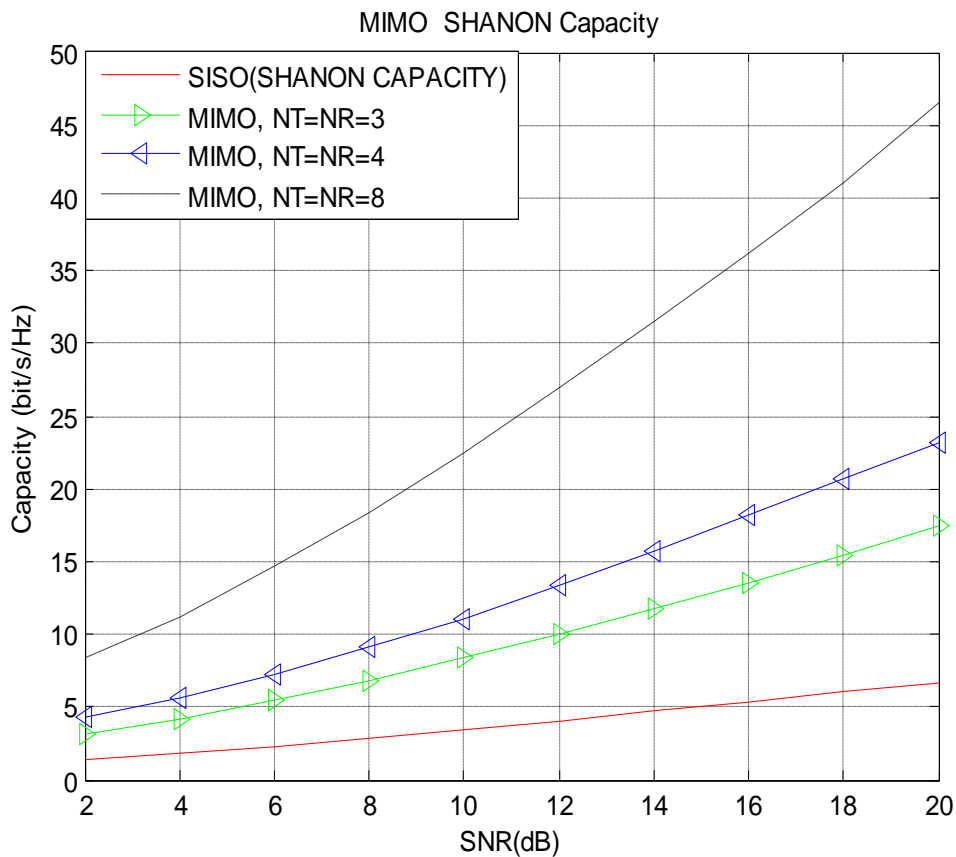

Figure 25: Shanon capacity vs. SNR(dB)

If we increase the number of transmitter and receiver the Shanon capacity increases. Because capacity C grows linearly with for $\min(N_t, N_R)$ for a given fixed transmitter power and bandwidth. In other words, without increasing the transmitted power or bandwidth the capacity of the wireless channel can be increased by simply increasing the number of transmitter and receiver antennas. This is an enormous improvement compared to a logarithmic increase in more traditional systems utilizing receiver diversity or no diversity. Shanon capacity is defined as $C = BW \log(1 + SNR)$

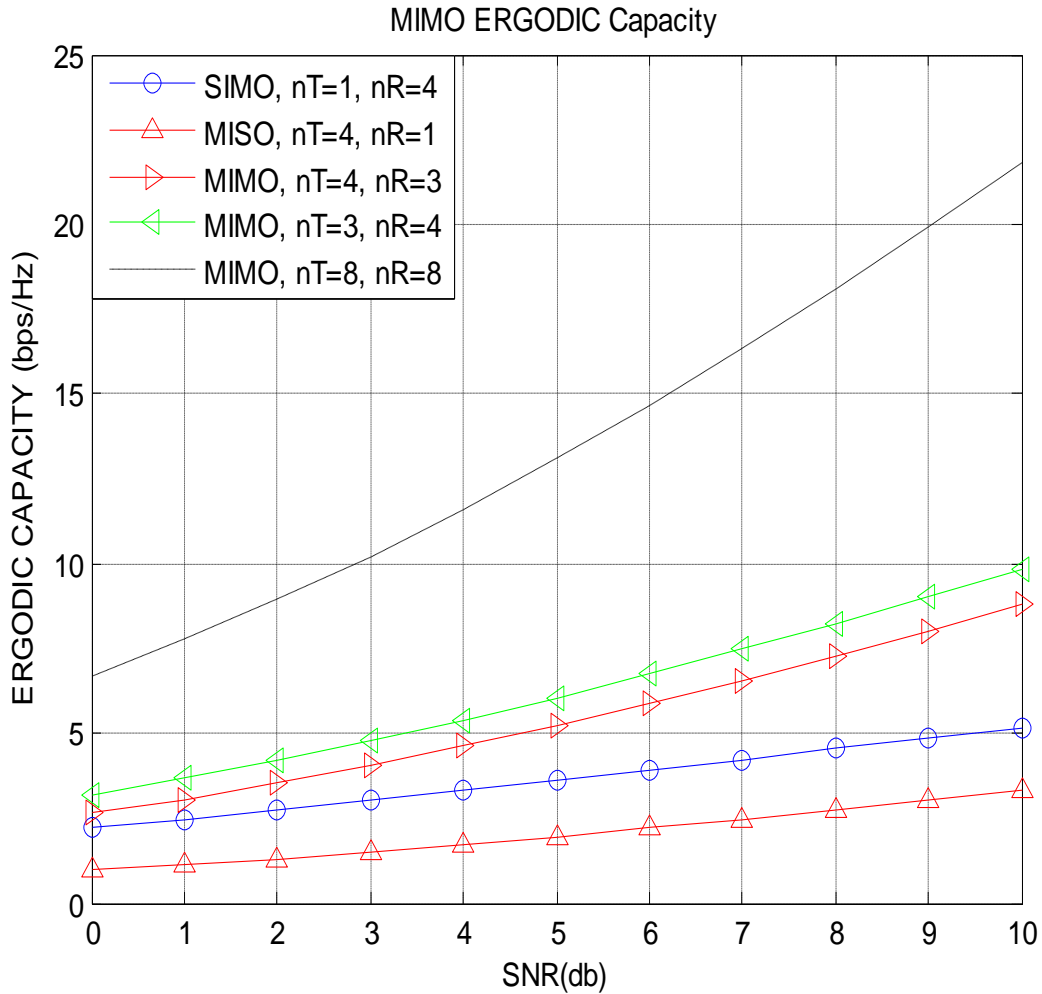

Figure 26: Ergodic channel capacity when CSI is not available at transmitter

When transmitter has no any idea of CSI it is optimal to evenly distribute the available power ρ among the transmit antennas. MIMO channels change randomly. Therefore, H is a random matrix, which means that its channel capacity is also randomly time-varying. In other words, the MIMO channel capacity can be given by its time average. In practice, we assume that the random channel is an ergodic process. As in figure ergodic channel capacity increases if we increase the number of transmitter and receiver because capacity C grows linearly with for $\min(N_t, N_R)$ for a given fixed transmitter power and bandwidth. The capacity of SIMO greater than MISO. Because MISO does not take the advantages of antenna array gain since it has no CSI.

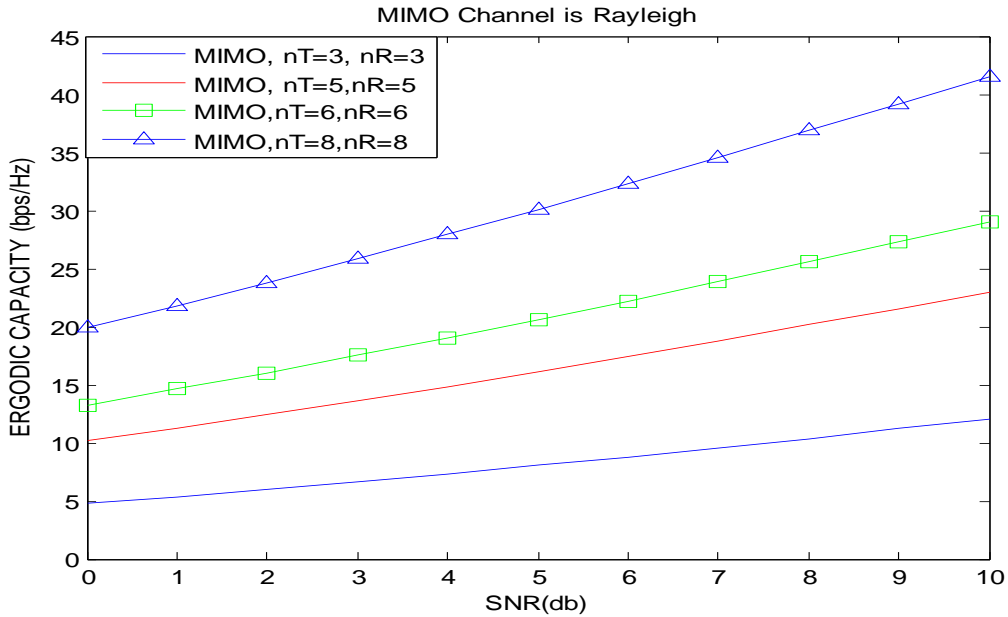

Figure 27; Ergodic channel capacity when CSI is available at transmitter

In other words, the MIMO channel capacity can be given by its time average. In practice, we assume that the random channel is an ergodic process. When CSI is present at transmitter channel capacity increases as compare to case when CSI is not present at transmitter. In figure as number of transmitter and receiver increases Channel capacity increases.

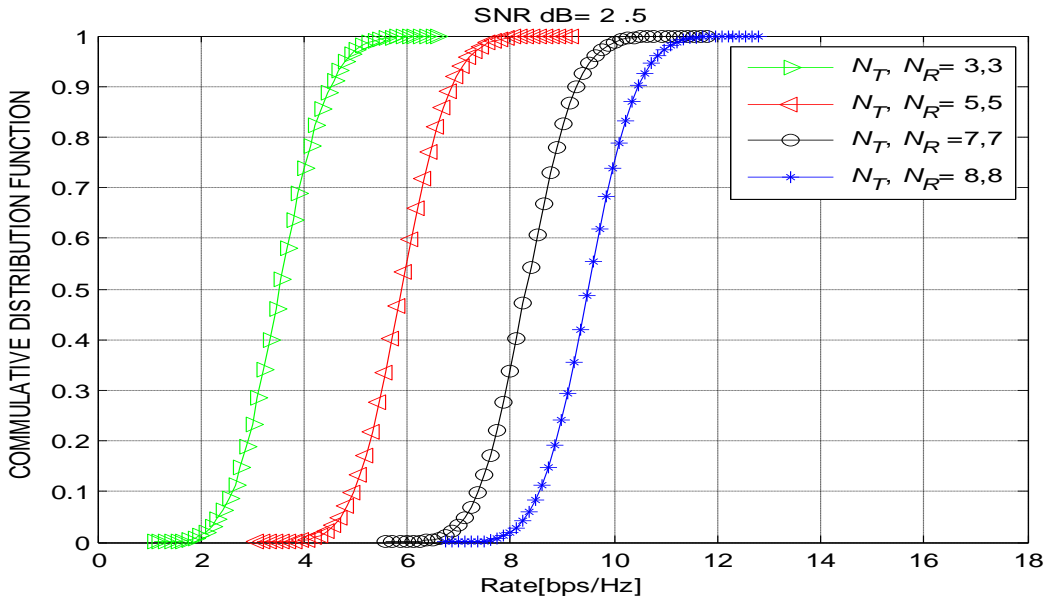

Figure 28: Distribution of MIMO channel capacity

Cumulative distribution function of MIMO increases if we increase the number of transmitter and receiver. In this figure CDF of 8x8 MIMO is greater than compare of other MIMO system . The cumulative distribution function (CDF), or just distribution function, describes the probability that a real-valued random variable X with a given probability distribution will be found at a value less than or equal to x . In the case of a continuous distribution, it gives the area under the probability density function from minus infinity to x . Cumulative distribution functions are also used to specify the distribution of multivariate random variables.

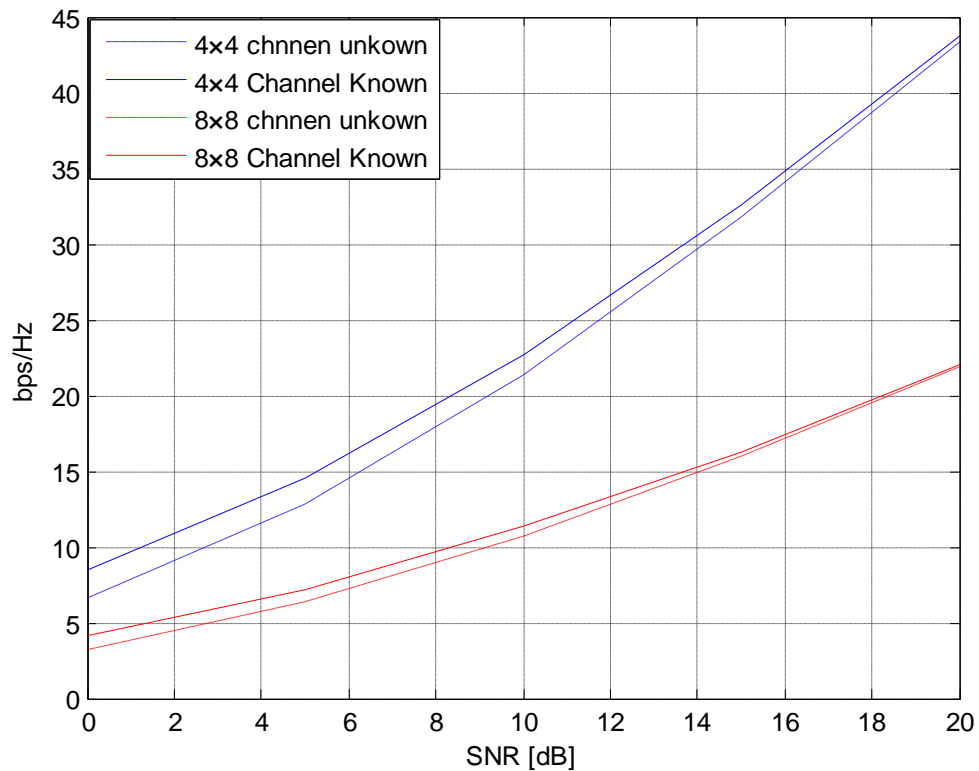

Figure 29: Channel unknown and known

In the case of channel known water filling algorithm method is used. MIMO (8x8) channel capacity more than as compare to MIMO (4X4) system. In this case we can use water pouring principle. In the case of water pouring principle the channel parameter are known to transmitter and more power is given to that channel which is in good condition or less or none which is in bad condition. The effect of channel known (in case of water pouring) is only occurring at low SNR. At higher SNR both capacity channel known or unknown approaches to equal

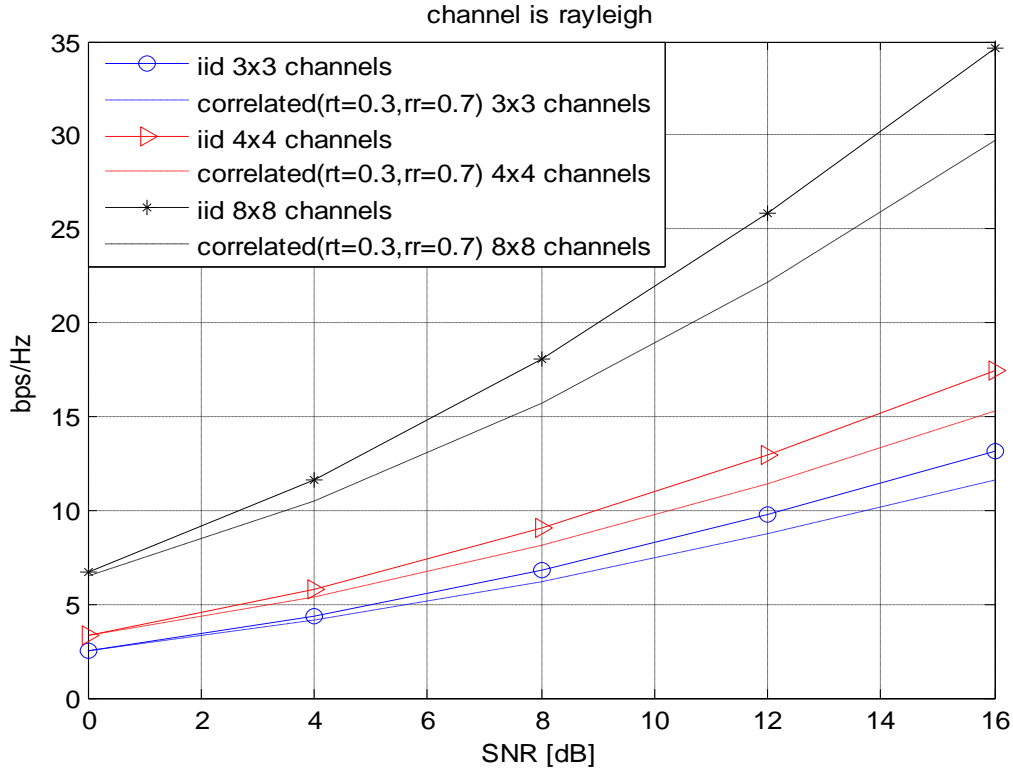

Figure 30: Effect of Correlation

Due to correlation channel capacity decreases. If we increase the number of transmitter and receiver the channel capacity increases. In general, the MIMO channel gains are not independent and identically distributed (i.i.d.). The channel correlation is closely related to the capacity of the MIMO channel. In the sequel, we consider the capacity of the MIMO channel when the channel gains between transmit antennas and received are correlated. Where R_t is the correlation matrix, reflecting the correlations between the transmit antennas (i.e., the correlations between the column vectors of H), R_r is the correlation matrix reflecting the correlations between the receive antennas (i.e., the correlations between the row vectors of H) received antennas are correlated.

Capacity with the outage allows bits sent over a given transmission burst to be decoded at the end of burst with some probability that these bits will be decoded incorrectly[49]. The transmitter fixes minimum received SNR m and encodes a data for $C = B \log(1 + m_{min})$. Data is properly received if received SNR is greater than m_{min} . If received SNR value is less than m

then there is probability that burst cannot be decoded properly approaches 1. Thus receiver declares as outage.

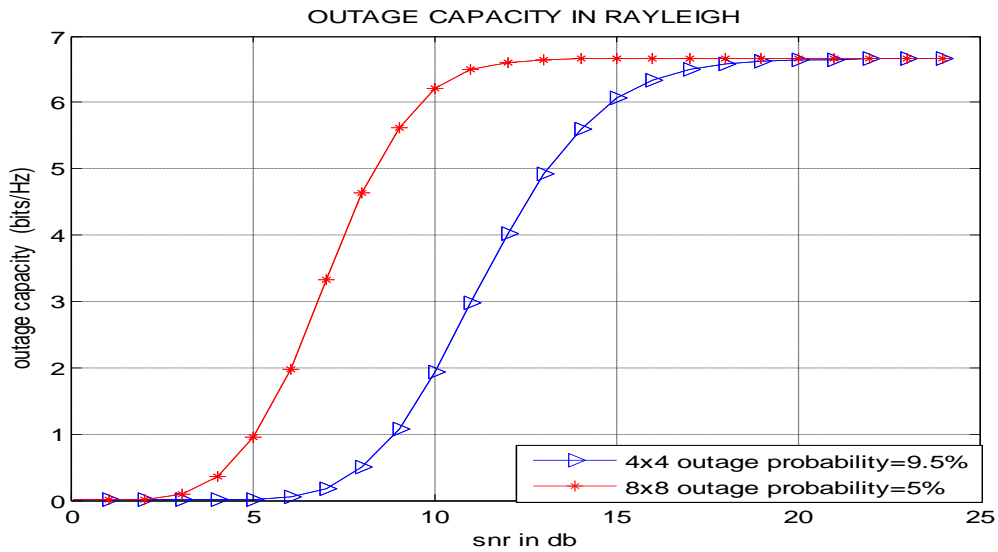

Figure 31; Outage capacity vs. SNR

Outage capacity of (8x8) MIMO is greater than (4x4) MIMO.

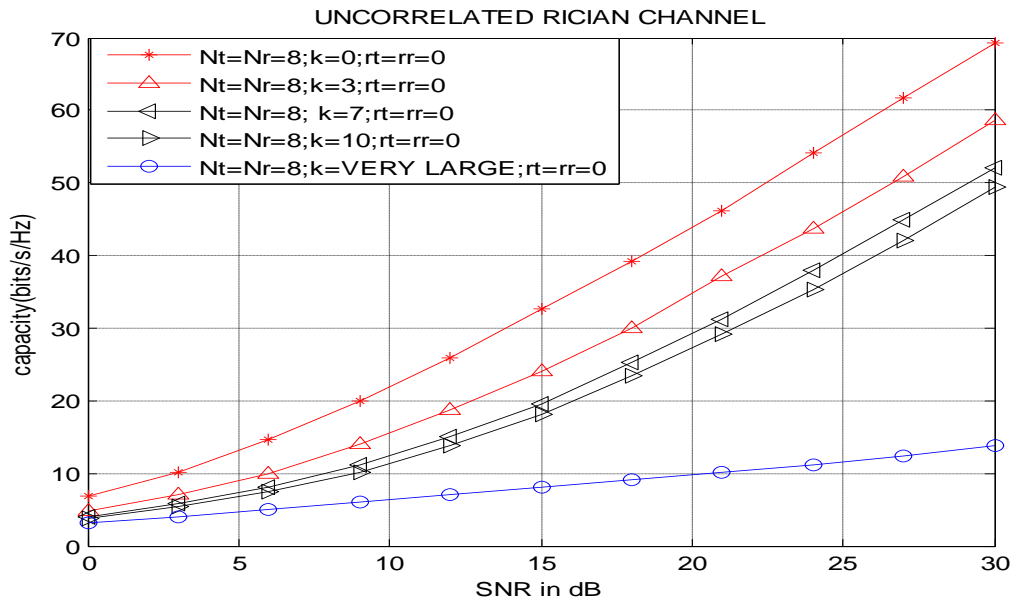

Figure 32 : Capacity analysis of uncorrelated rician channel when CSI is not present at transmitter

When $k=0$ channel is Rayleigh. As value of k increases capacity start to decrease. At very large value of k it acts as Gaussian channel. In this figure channel is uncorrelated. The MIMO channel

capacity has been studied for the Rayleigh scenario. On the other hand, in reality, MIMO channels do not always satisfy the i.i.d Rayleigh fading condition. In reality, there is often a line-of-sight (LOS) path between the transmitter and the receiver, and in such fading conditions, the channel is represented by the Rician fading model

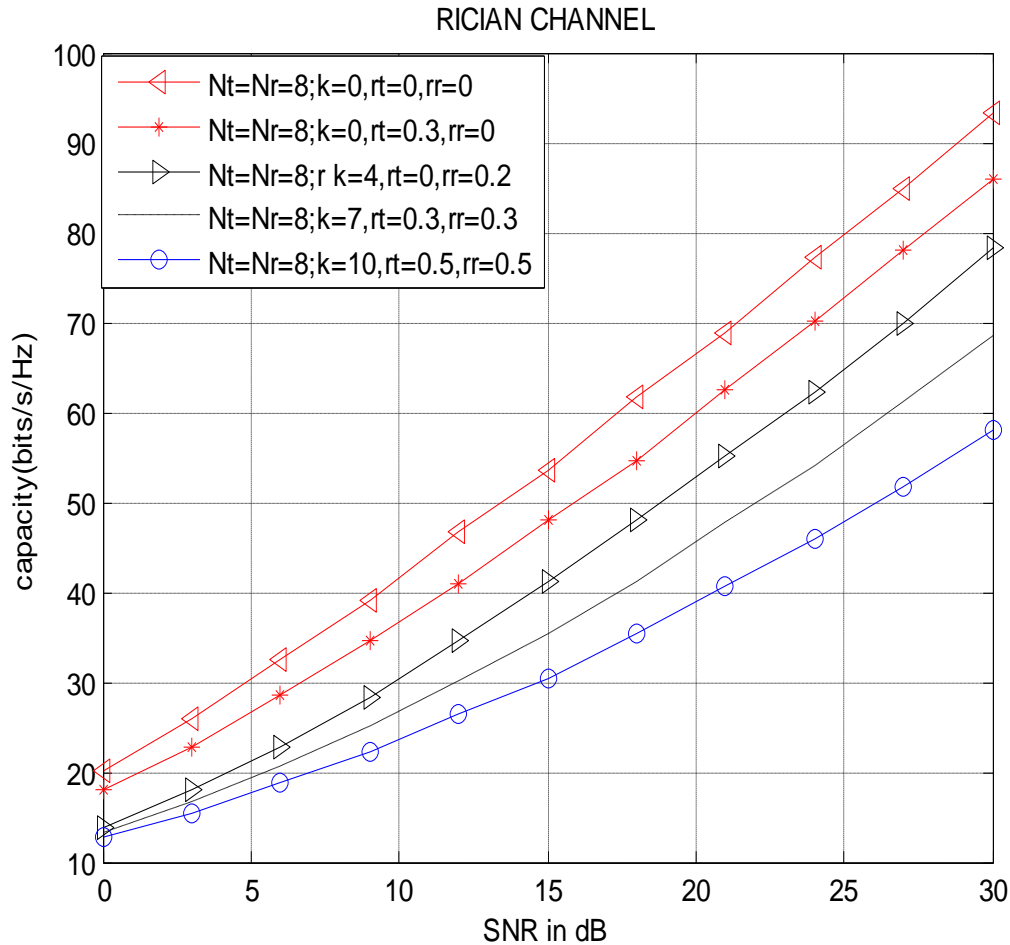

Figure 33: Rician channel capacity when transmitter knows the CSI under different correlation parameter

Rician channel capacity more when transmitter know the CSI as compare to when channel does not know the CSI. Correlation decreases the channel capacity. we consider the capacity of the MIMO channel when the channel gains between transmit and received antennas are correlated. Where R_t is the correlation matrix, reflecting the correlations between the transmit antennas (i.e., the correlations between the column vectors of H), R_r is the

correlation matrix reflecting the correlations between the receive antennas (i.e., the correlations between the row vectors of H),

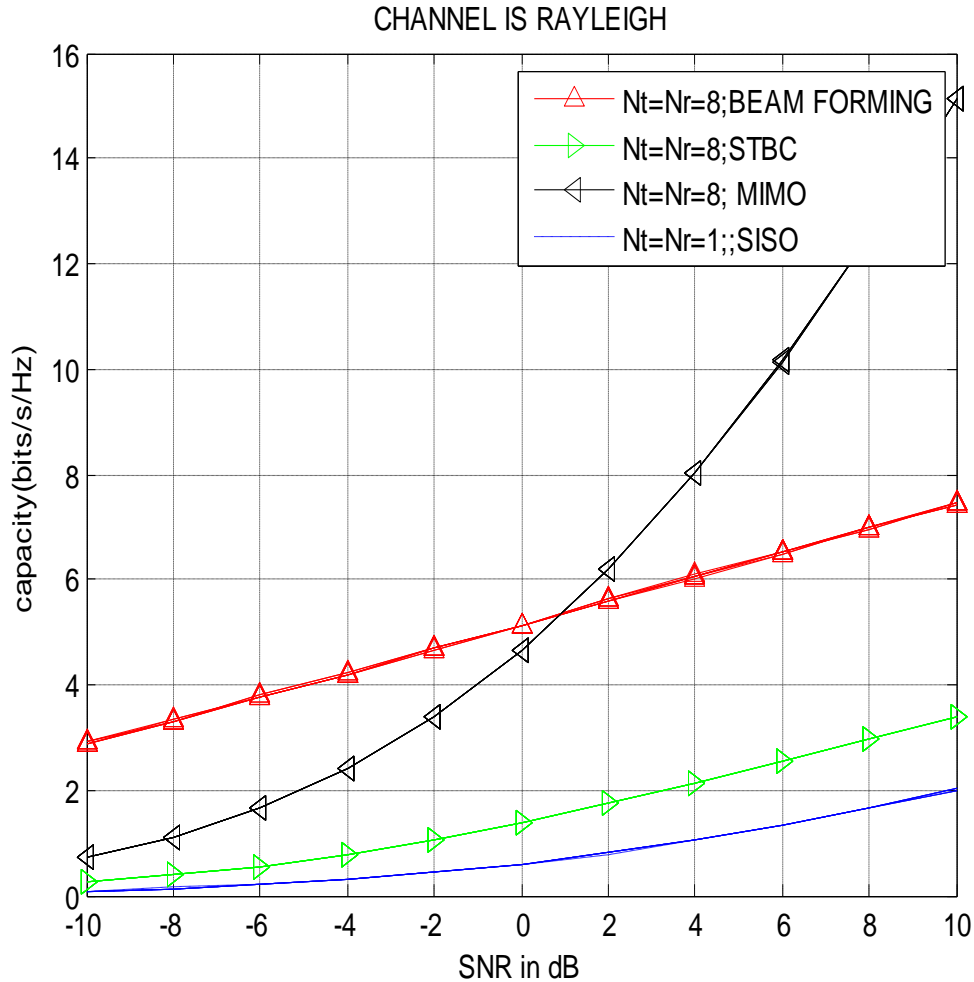

Figure 34 : Beamforming

In beamforming, the same signal is transmitted from each of the transmit antennas with different phase. Weighting such that the signal power is maximized at the receiver input. Beamforming increase the system gain at the receive side by making signals emitted from different antennas add up constructively, and to reduce the multipath fading effect. Beamforming capacity increases if there is increase in transmitter and receiver Ergodic capacity increases if we increase the relay between transmitter and receiver. Wireless relaying networks have recently been given considerable attention due to their many advantages.

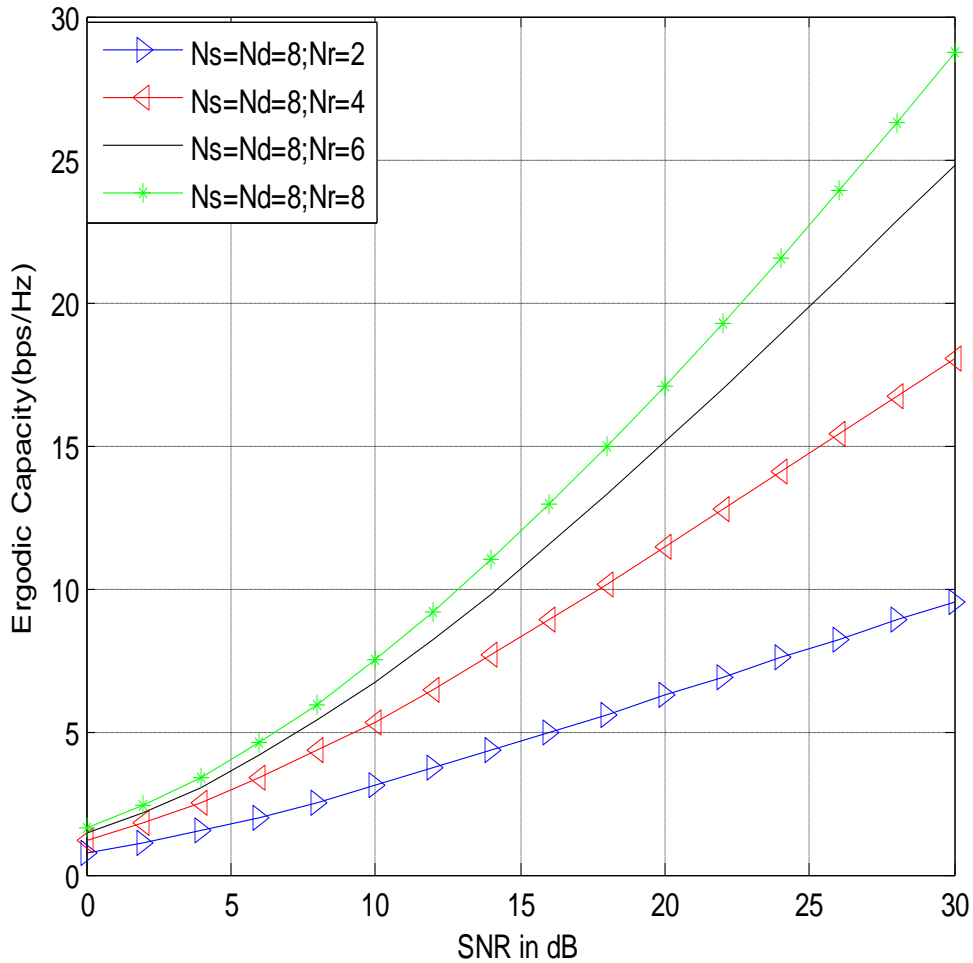

Figure 35: Ergodic channel capacity vs. SNR in dB

Apart from increasing the range, relaying networks can also achieve better diversity by using cooperative transmission from the source and several relays. The relaying terminals forward the information from the source to the destination mainly using the well-known method AF since MIMO systems can provide better system capacity than SISO, SIMO and MISO systems. As we increase the number of relay between transmitter and receiver channel capacity increases.

In multiplexing, a high rate signal is broken into multiple lower rate streams and each stream is transmitted from a different transmit antenna in the same frequency channel. In diversity method same signal is transmitted from different antenna. In the case of diversity bit error rate is less when compare to multiplexing.

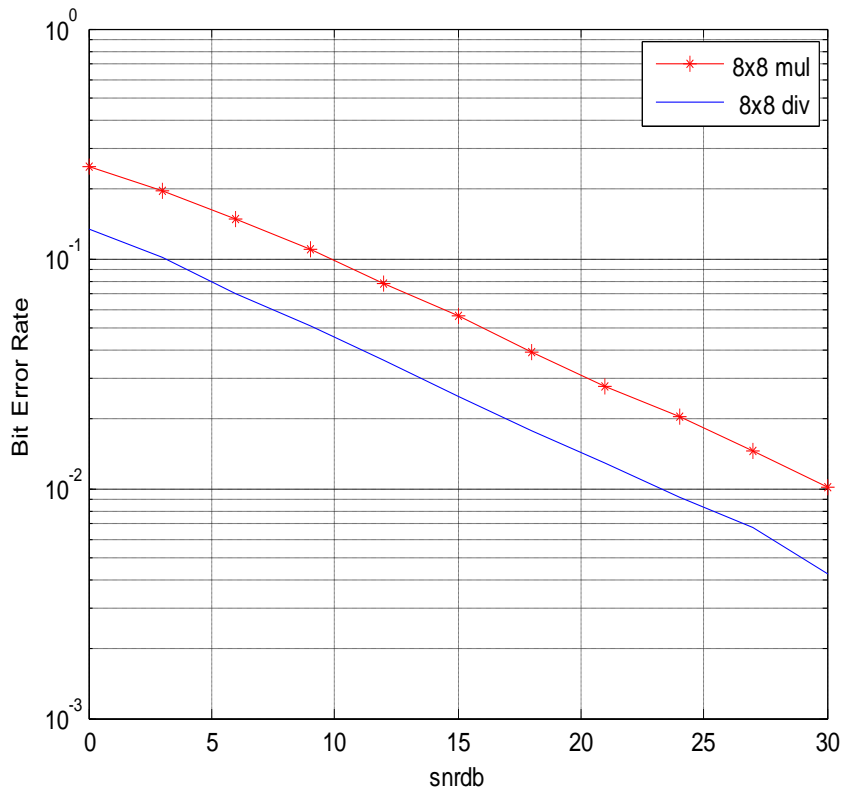

Figure 36: ZF Detection for multiplexing and diversity techniques

The ZF is a linear estimation technique, which inverse the frequency response of received signal. The inverse is taken for the restoration of signal after the channel. The estimation of strongest transmitted signal is obtained by nulling out the weaker transmitted signal. The strongest signal is than subtracted from received signal and proceeded to decode strong signal from the remaining transmitted signals. BER in Multiplexing(8x8) MIMO is greater than diversity(8x8) MIMO.

Minimum mean square error equalizer minimizes the mean –square error between the outputs of the equalizer and the transmitted symbol, which is a stochastic gradient algorithm with low complexity. Unlike a ZF equalizer, an MMSE equalizer maximizes the signal–to–distortion ratio by penalizing both residual ISI and noise enhancement. Instead of removing ISI completely, an MMSE equalizer allows some residual ISI to minimize the overall distortion.

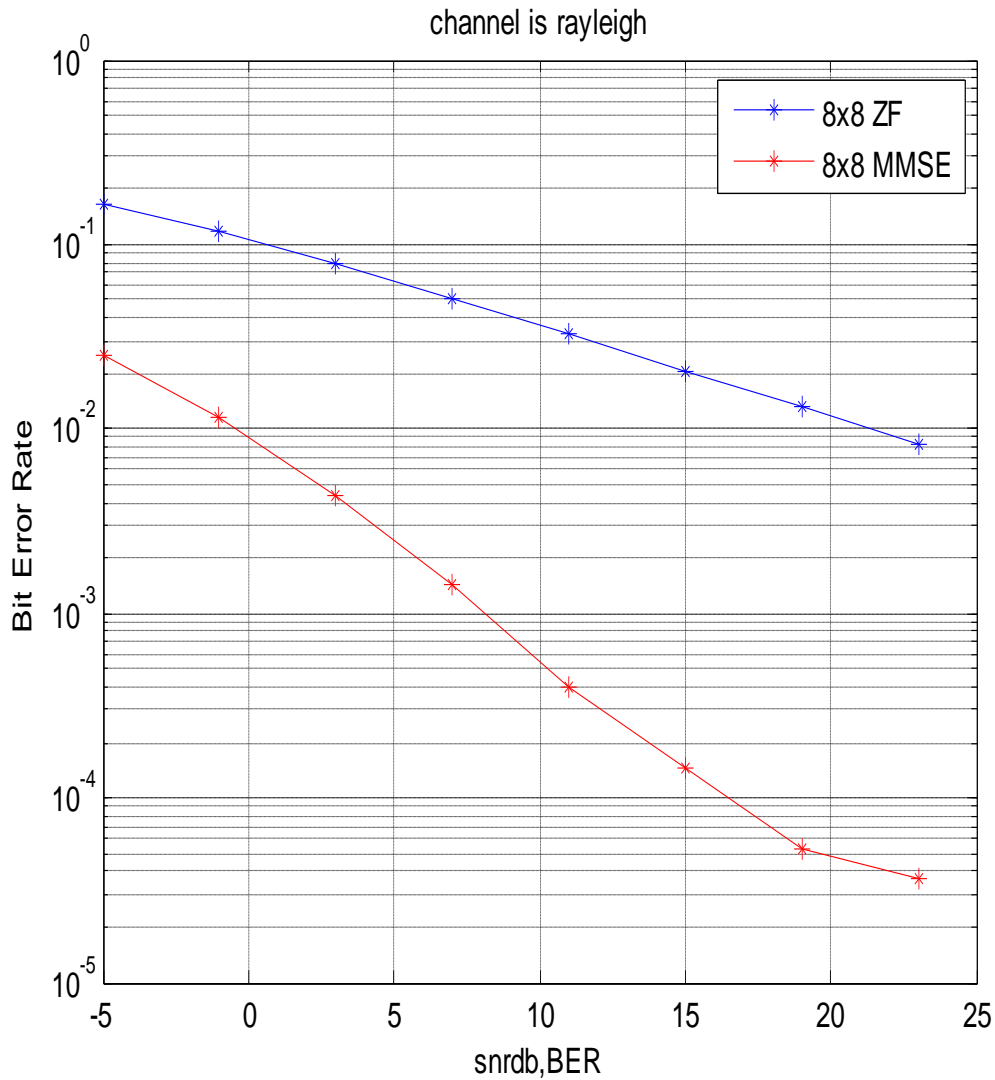

Figure 37 : Comparison between ZF and MMSE Detection

When the noise term is zero, the MMSE detector reduces to Zero Forcing detector. Bit error rate in MMSE is less than when compare to ZF.

The Maximum Likelihood (ML) detection is a scheme well known to be very robust and well suited for practical implementation whereas linear receiver suffers from numerical complexity. ML detector is the optimal receiver in terms of bit error rate (detector performance) but it is a nonlinear detector with a high complexity

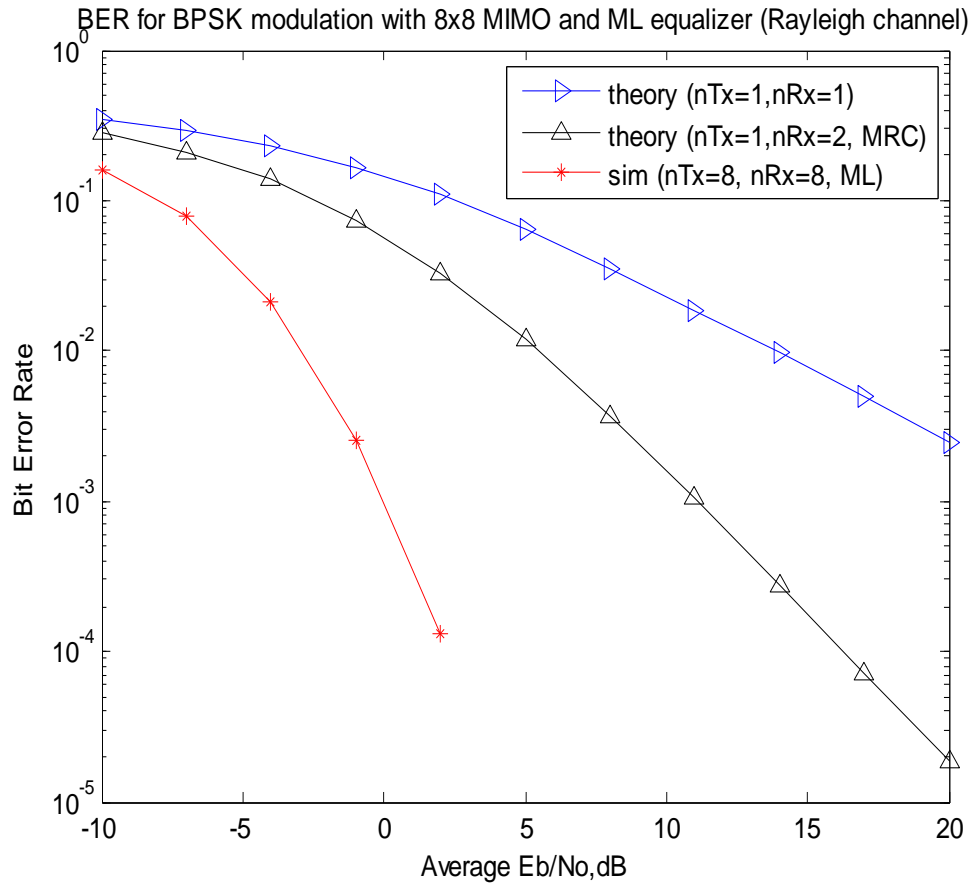

Figure 38: BER for ML detection techniques

If we increase the number of transmitting and receiving antenna BER start to reduce.

Chapter 6 Conclusion and Future scope

In the case of MIMO if we increase the number of transmitter and receiver MIMO channel capacity increases and BER reduces. By using (8x8) MIMO system capacity we can increase MIMO capacity and reduce the BER. But MIMO complexity increases if we increase number of transmitter and receiver to large extent. CSI plays important factor during channel capacity. If transmitter has no idea of CSI then equal power is allocate to each transmitter. Capacity increases if transmitter knows the CSI. Water pouring principle can be used when transmitter know the CSI. In the case of water pouring principle the channel parameter are known to transmitter and more power is given to that channel which is in good condition or less or none which is in bad condition. CSI effects at only lower SNR at higher SNR its effect is negligible. Correlation plays important factor during channel capacity. Correlation at transmitter and receiver decrease the channel capacity. In the case of Rician channel if we increase the value of k then channel capacity decreases. If value of k is equal to zero then channel acts as Rayleigh. If value of k increases the capacity decreases. At very high value of k channel acts as Gaussian channel. For $m \times m$ MIMO systems, we found that for all values of m , as the value of K increases, the ergodic and the decreases. However, the loss in the capacity is more at higher values of m . For uncorrelated fading channels, increase in K factor improves the BER error rate (BER). The MMSE method plays central role to get better result of BER for MIMO comparing to other technique but regarding complexity the ML perform better. The relaying terminals forward the information from the source to the destination mainly using the well-known method AF since MIMO systems can provide better system capacity than SISO, SIMO and MISO systems, relaying has recently been extended to MIMO. MIMO relays aim to provide improved system capacity, increases in range, and better diversity as traditional communication system. In the case of MIMO (4,3) when CSI is not present at transmitter then at SNR (dB) 5, 10 the capacity results for Rayleigh channels are 4(bps/Hz), 13(bps/Hz). But in case of (8x8) MIMO capacity become 13.5(bps/Hz), 22 (bps/Hz) for taking same condition. When transmitter know the CSI then at 5(dB), 10(dB) the capacity for MIMO(8X8) become 29.5 (bps/Hz), 41(bps/Hz). So there is increase in capacity when number of transmitter and receiver increases. In case of Rician

channel at 30(dB), $k=0$ the capacity for(8x8) is 70(bps/Hz),at $k=3$ the capacity is 59(bps/Hz) and at $k=7$ capacity becomes 52(bps/Hz).As value of k increases the capacity of Rician fading channel continuously decreases. The capacity of MIMO (8x8) for $k=10$ ($r_t=0.5, r_r=0.5$) at 30 (dB) become 59(bps/Hz) .Increasing channel correlation (r) reduces the capacity of the system. Ergodic capacity of MIMO (8x8) when there are eight relay between transmitter and receiver at 30 (dB) is 28(bps/Hz). Ergodic capacity of MIMO (8x8) when there are four relay between transmitter and receiver at 30 (dB) is 24(bps/Hz). So as number of relay between transmitter and receiver increases it increases the capacity. The BER rate of MMSE detection techniques for MIMO (8X8) is less than as compare of BER for ZF detection techniques at same SNR

FUTURE SCOPE

The work in this thesis can be extending to multiple users. Multiple user can add another dimension to the multiple antenna. Given a constraint on the total transmitted power, it is possible to give varying fractions of that power to different users in the network, another extension of work to get analytical results of channel capacity, diversity and MIMO detection techniques. Recently it is try to substitute the non logarithmic scale of Shanon capacity with analytical solution using fundamental approximation. but these results are limited to uncorrelated channel and not to correlated. Work can be extending to different MIMO detection techniques using linear and non linear method. Work can be extend to find out but is the effect of different value of k and correlation parameter on Rician MIMO capacity.

REFERENCES

- [1] T. S. Rappaport, *Wireless Communications: Principles and Practice*, 2nd edition, Prentice Hall, 2002.
- [2] Mohinder Jankiraman, *Space-Time Codes and MIMO Systems*, 2nd edition, British Library, Cataloguing in Publication Data, 2004.
- [3] Akbar Sayeed and Nader Behdad, "Continuous Aperture Phased MIMO: Basic Theory and Applications", *Forty-Eighth Annual Allerton Conference Allerton House, UIUC, Illinois, USA*, pp. 1196 - 1203, 2010.
- [4] A. Paulraj, R. Nabar, and D. Gore, *Introduction to space time Wireless Communication*, Cambridge University Press, New York, 2005.
- [5] Angel Lozano and Nihar Jindal, "Transmit Diversity vs. Spatial Multiplexing in Modern MIMO System", *IEEE Transactions on Wireless Communication*, vol. 9, no.1, pp. 186-22, 2010.
- [6] Yonghua Li, Lin Zhang, Dong Liang and Tiejun Lv, "Relation between Beamforming and Diversity in MIMO System: A Capacity Perspective" *5th International Conference on Wireless Communication Networking and Mobile Computing*, Beijing, China, pp. 1-4, 2009
- [7] R.B. Ertel, P. Cardieri, K.W. Sowerby, T.S. Rappaport, and J.H. Reed, "Overview Spatial Channel Models for Antenna Array Communication Systems", *IEEE Personal Communication*, vol. 5, no. 1, pp. 10-22, 1998.
- [8] G.J.Foschini. and M.J.Gans, "On the Limits of Wireless Communication in a Fading Environment When Using Multiple Antennas" *Wireless Communications*, vol.6, no. 3, pp. 226-235, 1998.
- [9] I. E. Telatar, "Capacity of multi-antenna Gaussian channels", *European Transactions on Telecommunication*, vol. 10, no.6, pp. 585 - 595, 1999.
- [10] S. Loyaka, "Channel capacity of MIMO architecture using exponential correlation matrix," *IEEE Communication Letters*, vol. 5, no. 9, pp. 369-371, 2001.
- [11] D. Gesbert, H. Bolcskei, D. J. Gore and A. J. Paulraj, "Outdoor MIMO wireless channels: Models and Performance prediction", *IEEE Transactions*

- Communication*, vol. 50 , no. 12, pp. 1926 – 1934, 2002.
- [12] F. R. Farrokhi, G. J. Foschini, A. Lozano and R.A . Valenzuela, “Linkoptimal Space–time processing with multiple transmit and receive antennas,” *IEEE Commun. Letters*, vol. 5, no. 3, pp. 85-87, 2001.
- [13] S. S. M. S. and A .Paulraj, “Space- Time Block Codes: A Capacity Perspective”, *IEEE Communication. Letters* , vol. 4, no. 12, pp 384-386, 2000.
- [14] M. Sharif, and B. Hassibi, “ On the capacity of MIMO broadcast channels with partial side information”, *IEEE Transaction on Information Theory*, vol. 51,no. 2, pp. 506–522, 2005.
- [15] Peter J. Smith Lee and M. Garth, ” Exact Capacity Distribution for Dual MIMO Systems in Ricean Fading” *IEEE Communication Letters*, vol. 8, no.1, pp. 18 - 20 , 2004.
- [16] Da –Shan Shiu, Gerard J. Foschini and Michael J. Gans, Joseph M. Kahn,” Fading Correlation and its Effect on the Capacity of Multielement Antenna Systems”*IEEE Transaction Communication*, vol. 48, no. 3, pp.502 - 513 2000 .
- [17] Rohit U. Nabar ,Helmut Bölcskei,and Arogyaswami andJ. Paulraj, “Diversity And Outage Performance in Space–Time Block Coded Ricean MIMO Channels”,*IEEE Transactions on Wireless Communication*, vol. 4, no.5 ,pp. 2519 - 2532 ,2005.
- [18] Ligang Ren, Zhijie Yan, Mei Song and Jude Song.,"An Improved Water-Filling For Algorithm Mobile MIMO Communication Systems over Time Varying Fadin Channels ", *Wireless Networks Communications International Conference* vol. no.35, pp. 629-632, 2004.
- [19] S. M. Alamouti,“ A simple transmit diversity technique for wireless communications”, *IEEE Journal of Selected. Areas Communication.*, vol. 16, no.35, pp.1451-1458, 1998.
- [20] E. Riegler and G . Taricco, “Asymptotic statistics of the Mutual Information on Spatially correlated Rician fading MIMO channels with interference”, *IEEE Transactions on Information Theory*, vol. 56, no. 4 pp. 1542-1559, 2010.

- [21] Bengt Holter, "On the capacity of the MIMO channel: -A tutorial introduction", *IEEE Norwegian Symposium on Signal Processing*, vol. 1, no 5, pp. 167-172, 2001.
- [22] Giorgio Taricco and Erwin Riegler, "On the ergodic capacity of correlated Rician Fading MIMO channels with interference", *IEEE Transactions on Information Theory*, vol. 57, no.4, pp. 4123-4137, 2011.
- [23] M. Qingyu, Afif Osseiran and Gan Jiansong, "MIMO Amplify - and-Forward relaying: spatial gain and filter matrix design", *IEEE Communications Society*, vol.1, pp. 26-30, 2008.
- [24] Yue Rong and Yong Xiang, "Multiuser multi- hop MIMO relay systems with correlated fading channels", *IEEE Transactions on Wireless Communications*, vol. 10, no.9, pp. 2835-2841, 2011.
- [25] G. Raleigh and J.M. Cioffi, "Spatial temporal coding for wireless communication ", *IEEE Transactions on Wireless Communications*, Vol. 46, no.3, pp.357-366, 1998.
- [26] Trungtan Nguyen, Weixiao Meng, Hongyu Wang, "Channel Capacity Analysis on Cooperative MIMO with Antenna Spatial Correlation and Multi-path" *6th International Conference on Communication and Networking in China*, Harbin, China, pp.181-185, 2001.
- [27] Chao-Kai Wen, Shi Jin, Kai-Kit Wong, Jung-Chieh Chen, and Pangan Ting "On the Ergodic Capacity of Jointly -Correlated Rician Fading MIMO Channels" *IEEE international conference on Acoustics speech and signal Processing*, pp. 3224 – 3227, 2011.
- [28] Giorgio Taricco, and Erwin Riegler, "On the Ergodic Capacity of Correlated Rician Fading MIMO Channels With Interference" *IEEE Transactions on Information Theory*, vol. 57, no. 7, pp. 4123 – 4137, 2011.
- [29] Constantin Siriteanu, Xiaonan Shi and Yoshikazu Miyayaga, "Analysis and Simulation of MIMO Zero-Forcing Detection Performance for Correlated and Estimated Rician- Fading Channel", *Communication Theory workshop (AusCTW)*, Australia, pp.182 – 187, 2010.

- [30] Tharwat Morsy and Klaus Hueske, "Analysis of a Reduced Complexity Generalized Minimum Mean Square Error Detector", *7th international Symposium on Wireless communication system*, York, pp. 496-500, 2010
- [31] Xiwu Lv, Kaihua Liu and Yongtao Ma, "Some results on the capacity of MIMO Rayleigh fading channels", *6th International Conference on Wire Communication Networking and Mobile Computing*, Chengdu, pp. 1-4, 2010.
- [32] Zhongliang Fan, Yongsheng Wang, Ding Wang and Jintao Hu, "Low Complexity MIMO Detector Based on Combination of MRC and MMSE Algorithm", *2nd International Conference on Future Computer and Communication*, Wuhan, pp.V1-442 - V1-447, 2010.
- [33] Jeffrey G. Andrews, Arunabha Ghosh, and Rais Mohamed, *Fundamentals of WiMAX: Understanding Broadband Wireless Networking*, Prentice Hall, 2007.
- [34] J. C. Liberti and T. S. Rappaport, "A Geometrically Based Model for Line-of-Sight Multipath Radio Channels", *IEEE Vehicular Technology Conference*, Atlanta, vol.12, pp.844 – 848, 1996.
- [35] R.B. Ertel, P. Cardieri, K.W. Sowerby, T.S. Rappaport, and J.H. Reed, "Overview of Spatial Channel Models for Antenna Array Communication Systems," *IEEE Personal Communications*, vol. 5, no.1, pp.10-22, 1998.
- [36] Jeffrey G. Andrews, Arunabha Ghosh, and Rais Mohamed, "Fundamentals of WiMAX: Understanding Broadband Wireless Networking", Prentice Hall, 2007.
- [37] S. M. Alamouti, "A simple transmit diversity technique for wireless communications", *IEEE Journal on Select Areas in Communications*, vol.16, no.8, pp.1451–1458, 1998.
- [38] V. Tarokh, H. Jafarkhani, and A. Calderbank, "Space-time block codes from orthogonal designs", *IEEE Transaction. on Information Theory*, vol. 45, no 5, pp. 1456-1467, 1999.
- [39] W. Van Etten, "An optimum linear receiver for multiple channel digital

- Transmission systems,” *IEEE Transaction Communication Theory*, vol. 23, no. 8 ,pp. 828 -834, 1975
- [40] Simon Haykin, and Michael Moher, "Modern Wireless Communications", Prentice-Hall Inc., 2005.
- [41] Stuber G. L.,Principles of Mobile Communication, Kluwer, Norwell, MA, 2001.
- [42] Ezio Biglieri," MIMO Wireless Communications", Cambridge University Press, 2007.
- [43] G. J. Foschini, “Layered space-time architecture for wireless communication in a fading environment when using multi-element antennas", *Bell Labs Tech. J.*, vol. 1, no. 2, pp. 41-59, 1996.
- [44] P. Lombardo, F. Fedele and M. M. Rao, “MRC Performance for Binary Signals in Nakagami Fading with General Branch Correlation”, *IEEE Transactions on Communications*, vol. 47, no. 1, pp.44-50, 1999
- [45] A. Wittneben and B. Rankov, “Impact of cooperative strategies and capacity Theorem for relay networks”, *Mobile and Wireless Communication Summit, Avero, Portugal*, vol. 2, pp. 421-425, 2003.
- [46] S. Jin, M. R.McKey and K.K. Wong, “Ergodic capacity analysis of amplifying And forward MIMO dual-hop system”, *IEEE Transaction on Information Theory*, vol. 56, no.5, pp. 3062-3080, 2004.
- [47] A.B.Gershman and N.D.Sidiropoulos,*Space-time Processing for MIMO system*, John Wiley&Sons, Chichester,2005.
- [48] S.Saudhu and A.Paulraj, “Space-Time Block Codes: A Capacity Perspective”, *IEEE Communications Letters*, vol.4, no 12 , pp. 384-386, 2000.
- [49] Gold Andera , Communication lecture reader. Stanford University.
- [50] X. Mestre, J. Fonolloosa, and A. Zamora, “Capacity of MIMO channels: Asymptotic evaluation under correlated fading”, *IEEE J. Selected Areas in Communication*, vol. 21, no. 5, pp. 829-838, 2003.
- [51] G. Leus, S. Zhou, and G. B. Giannakis, “Orthogonal multiple access over time and frequency selective channels”, *IEEE Transactions on Information Theory*, vol. 49, no. 8, pp. 1942–1950, 2003.

- [52] Toshiaki. K. “ Low- Complexity Systolic V-BLAST Architecture”, *IEEE Transactions on Wireless Communications*, vol. 8, no5, pp. 2172 - 2176 2009.
- [53] R.Schotz, “Multiple Access with Time- Hoping Impulse Modulation”,*IEEE Milit. Hoping Impulse Modulation, Communication . Confrence*, vol . 2, pp. 447-450,1993
- [54] Taekyu Kim and Sin- Chong Park. “Reduced Complexity Detection for V-Blast D Systems from Iteration Canceling”, *The 23rd International Technical Conference on Circuits/Systems, Computers and Communications* 2008.
- [55] Toshiaki. K. “ Low-Complexity Systolic V-BLAST Architecture ”, *IEEE Transactions on Wireless Communications*, vol. 8, no.5, pp. 2172 – 2176, 2009.

