

Synthesis of Silver Coated Silica Based Nano-fluids and to study their Thermo-Physical Properties and Heat Transfer Application

Thesis submitted by

Milan

(Roll no 301402010)

In the fulfillment of the requirement of

Degree of Masters in Chemistry



Under the joint supervision of

Dr. Bonamali Pal

(Professor and Head)

School of Chemistry and Biochemistry

Dr. S. S. Mallick

(Associate Professor)

Mechanical Engineering Dept.

Thapar University, Patiala-147004

Punjab, (India)

July 2016

Certificate

This is to certify that the thesis entitled “synthesis of silver coated nano fluids and to study their thermo physical properties and heat transfer applications” being submitted by Ms Milan in fulfillment of the partial requirement for the award of degree of masters (chemistry) in the school of Chemistry and Bio-chemistry Thapar University Patiala, and the project work was carried out by her under my supervision and guidance.

(Supervisor and Head)

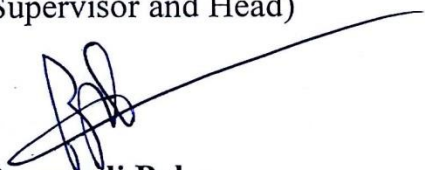

Dr. Bonamali Pal

Professor and Head

School of Chemistry and Bio-chemistry

Thapar University Patiala (147004)

Punjab (India)

Co-supervisor



Dr. S.S Mallick

Associate Professor

Department of mechanical engineering

Thapar University Patiala (147004)

Punjab (India)

Dr. Bonamali Pal



Professor and Head

School of Chemistry and Bio-chemistry

Thapar University Patiala (147004)



Dr. S.S Bhatia



Dean of Academics', Affairs
Thapar University, Patiala

Candidate's Declaration

I, hereby declare the work presented in the thesis entitled **“Synthesis of nano-fluid and to study their thermo-physical properties and heat transfer applications”** in fulfillment of the requirement of for the award of degree of masters of Science being sub-mitted to school of chemistry and bio-chemistry, Thapar University, Patiala is an authentic record of my work carried out under the supervision of Dr. Bonamali Pal (Head of school of chemistry and Bio-chemistry) and Dr. S.S.Mallick(Associate Professor in department of Mechanical Engineering) in Thapar University Patiala, Punjab .

Place: *Patiala*

Date: *8-July-2016*

Milau

(Milan Ahuja)

Acknowledgement

A major project is never the work of anyone alone. The contribution of many different people in their different ways made this possible. A statement of thanks is of evident to inculcate my deep sense of gratitude and obligations to all those who helped me in the work of thesis. It has been great honor and privilege to undergo my project in Department of Chemistry, Thapar University, and Patiala.

First and foremost I am extremely thankful to my both research supervisors, Dr. Bonamali Pal (Prof. and Head of School of Chemistry and Biochemistry) and Dr. S. S. Mallick (Associate Prof. in Department of Mechanical Engineering), for his valuable supervision and consistent encouragement throughout the research work. They always made it a point to be available to clarify my doubts despite of their busy schedules and I consider it as a great opportunity to do my research program under their guidance and learnt the techniques of research expertise.

I would like to say thanks to the faculty members Dr. Gautam Setia, Kundal Lal Sir and Atul Sharma from Mechanical Engineering Department for their engineering guidance.

I am also thankful to my research lab members Ms Tanushree Basu Rahees Ahmed, Bhupender Pal, R. C. Prajapat, Smriti Maa'm, Sakshi Bhardwaj.

I am also thankful to my batch mates of project (Udita Wadhawa, Darshan, Tejasvi, Arshdeep Singh, Amit, Shailender,) from Mechanical

Engineering Department. I gained a lot from them through their personal and scholarly interactions.

Besides this, I am thankful to the persons who knowingly and unknowingly helped me in successful completion of the work.

Chapter	Section	Contents	Page No
		List of symbols/abbreviations	i-ii
		Abstract	iii
1	Introduction and objectives		
	1.1	Introduction	1-3
	1.2	objectives	
	Literature review		
2	2.1	New methods for the preparations of nano-fluids	
	2.2	Various factors affecting the thermal conductivity of nano-fluids	4-16
	2.3	Mechanisms for thermal conduction in nano-fluids	
	2.4	Characterizations of nano-fluids	
	2.5	Research Gap	
	Experimental		
3	3.1	Experimental work done	
	3.1.1	Materials and methods used	17-26
	3.2	Synthesis of nano-particles	
	3.3	Preparations of nano-fluids	
	3.4	Different characterization	

		techniques used and interpretations of result	
	3.5	SEM morphologies and result analyses	
	3.6	TEM interpretations of Ag coated Si nanoparticles	
		Thermo-physical properties testing	
4	4.1	Thermo-physical properties measurement	
	4.2	Thermal properties analyzer working Experimentally	
	4.3	Thermal conductivity testing and results	27-39
	4.4	Heat transfer coefficient measurements	
	4.5	Applications of thermal conductivity and heat transfer	
5	5.1	Schematic of double tube heat exchanger	
	5.2	Conclusions	40-41
	5.3	Future scope of work	
		References	

List of Abbreviations and Symbols

TC	Thermal conductivity
NPs	nano-Particles
NFs	nano-fluids
Vol%	Volume percentage
H ₂ O	water
1-d	One Dimensional
EG	ethylene-glycol
DIW	de-ionized water
T	temperature
IEP	Iso-electric point
SDS	Sodium do-decayl sulphate
SDBS	Sodium do-decyl Benzene Sulphate
PVP	poly vinyl pyrrolidone
mM	milli-molar
DLS	dynamic light scattering
Vis	visible
HR-TEM	high resolution transmission electron
TEM	transmission electron microscopy
SEM	scanning electron microscope
L	length
a.u	arbitrary unit
Mg	milligram
g	gram
s	second

Abstract

In these present studies of work synthesis of silver coated silica nano-particles were synthesized and by using various techniques they were converted into nano-fluids. Nano-fluids play a very important role in today's world. Their thermo-physical properties such as thermal conductivity were studied and heat transfer co-efficient was calculated. In this work this is mainly based on the engineering applications of nano-fluids. by change in various parameters heat transfer co-efficient and thermal conductivity was measured. Results are mainly based on the applications of industrial cooling, heat engines etc.

Chapter 1 Introduction and objectives

In many past years, this nano-technology has emerged into a new generation of coolants known as nano-fluids in the form of suspensions. Serrano et al. [1] gives a lot of examples with the benefit of nano-sized materials in comparison to mille and micro sized. Nano fluid is basically dispersion of nano sized particles in any suitable base fluid, So the need of a fluid that can enhance the thermo-physical properties and heat transfer efficiency where the experimental investigations are concerned on thermal properties of nano-fluids.in comparison to other fluids water, oils etc nano fluids shows better thermo physical properties that's why they have various applications from industrial aspect too. There are various studies have been done by many researchers in thermal conductivity and in heat transfer systems where they have used in many cooling development systems and improvements are still doing especially for cooling capabilities. Nano fluids have shown there advantages and potentials for improving the thermal conductivity and heat transfer rates when they are using in various thermal systems. Nano fluids can be of different types with different ranges of nano particles .they can be solid liquids and suspended nano particles in various solution forms. Typical solid nano particles have a range 1-100 nm with high thermal conductivities and are suspended in various base fluids to make them stable in suspensions. Various types of nano particles which are synthesized such as Ag, Cu, Al, and TiO₂ based and converted into particular nano fluid which can enhance the effective thermal conductivity, heat transfer rates, viscosity and many thermo physical parameters in comparison to original base fluid which have low conductivity. Different nano fluids are selected on the basis of their different properties such as size shape, volume fractions and stability of nano particles in suspended forms.

In today's times from engineering aspect cooling is one of the great need because of heat generation rates on micro and macro levels both. There is various conventional heat transfer fluids present such as air, de-ionized water, ethylene glycol (E-G) etc. little enhancements can be done in liquids having their poor thermal conductivities by adding some solid particles in order to make them more beneficial for industrial purposes. If we see nano-particles in today's world they have more superior mechanical, optical, electrical, magnetic and thermal properties.

Different combinations of nano-particles with various base fluids are present to make them more stable suspensions. They include:

In oxides ceramic- Al_2O_3 , CuO, metal carbides, various combinations of nitrides, non-metals graphite nano-tubes, many other functionalized nano-particles whereas base fluids can be water, EG, oils and other lubricants, bio-fluids, polymer solutions.

Benefits of Technology and its Applications

Nano technology has many industrial applications which provide more efficient energy uses in various fields. While many applications not directly affect the energy transmission but has a capacity to reduce the need of electricity. Nano fluids have drawn a lot of attentions to many research groups for many industrial applications such as enhancements in cooling rates for so many devices. It have diverted researchers mind in various fields in many electronics devices such as coolants refrigeration systems, automotives and power generators. So almost in every energy system which has improved from this technology and get integrated into many other specific applications such as [2]

Applications of nano-fluids in heat transfer system

In cooling engines, Oil transmission, In exhaust gas recovery Electronics, cooling In transformer as cooling oil in form of nano-fluids, In solar water heating system, In drilling and refrigeration Defense areas Space aeronautics Thermal storage [3] In reduction of drag Bio-medical applications.

Importance of core shell nano-particles

They are gradually more attracting the attention because nano-particles have emerged between materials of chemistry and other fields such as biomedical, pharmaceutical etc. The properties of nano-sized materials are quite different because they can be further changed by constituent materials with their different core shells ratio. Here in this work because of shell material coating properties of core particles reactivity decreases and thermo physical properties such as heat transfer coefficient and thermal conductivity can be modified. The main purpose of coating is reduction in the consumption of precious materials [4].

In view of above followings are some specific objectives for work are as

1) Preparation of different types of nano-particles TiO_2 and silver coated silica of different shapes spherical, rods and their characterizations.

- 2) Surface modification of these and their dispersion stability and to evaluate the thermal conductivity of silver coated silica nano-particle with DI and EG as base fluids.
- 3) Characterization of silver-coated silica nano fluids and to measure their thermal conductivity and heat transfer co-efficient at various temperatures

Chapter 2 Literature review

2.1 Methods for preparation of nano fluids and their Advantages and disadvantages

There are two types of methods of preparations of nano-fluids by single step and two step methods (explained in details in chapter 2). Mainly nano-particles, nano-structures and nano-fluids are prepared by two step method. In this process first they are converted into the form of dry powders and then converted into nano-fluid. as nano-particles are smaller in size and have a great activity to get aggregates so many types of additional products can be added for making them stability.

There can be various base fluids that are used for thermal conductivity measurement which makes the suspension stable for a longer period of time as R.saleh et al./ postulated that thermal conductivity can be varied by using different metal nano-fluids of different oxides etc. this study basically focused on the fundamental transport properties such as viscosity ,ph, thermal conductivity how they vary with temperature and their compared values can be predicted by different models. Other effects can also be shown such as effect of adding surfactant to the nano-fluids and enhancement in the rate of thermal conductivity and heat transfer co-efficient. many research groups presented a lot of data stuff with variations in thermo physical properties by using different nano-fluids such as(Tio₂,Cu,Ag,Si,Au,CuO) etc. different methods are used for making poly-dispersed nano particles.

Types of nano-fluids

There can be various methods have been reported in literature to synthesize nano particles. Many types of nano-particles are often used to make nano-fluids such as metallic, non-metallic, carbon nano-tubes and nano-droplets[5].by made up from these various types of nano-fluids are investigated in many researchers work. In nano-fluid mainly suspensions are formed but in recent studies a new type of nano-emulsions[6] are reported which are in dispersed phase with nano-droplets.in the work of enhancement of thermal conductivity and heat transfer, nano-droplets plays a very important role. Ma [7] reported a very new system which consists of nano fluids of liquid metal.

2.2 Various factors affecting and stability concerns issues for the thermal conductivity of nano-fluids:

Main most crucial problem with these is they get aggregated within the solution, so agglomeration is also a kind of major issue about the stability of nano-fluids. so for improving this issue various surfactant and stabilizers are added to nano-particles which enhance the stability of solutions. Challenges come in measurement of thermal conductivity.

- Particles nature and properties changes due to Brownian motion.
- Particle agglomeration and aggregation changes the properties at certain temperature differences.
- For e.g. Pak and Cho [8] reported the 10% volume of Al₂O₃ shows an increase in viscosity within the nano-fluid but gives low concentration of energy transfer.

In last years of studies thermal conductivity and its applications diverted the researchers mind towards nano-fluids, but recent studies also shows the benefits of heat and mass transfer properties too.

Major problems reported from results of different researchers and previous attempts

- Results obtained from different groups have a lack of agreements among each other.
- In characterizations of suspensions.

(Problems come from theoretical understanding in mechanisms due to which properties of nano-fluids get changed.)

As less work has been done to overcome these problems in the field of nano-fluids, how we can improve various thermo physical properties of nano-fluids in contrast to above mentioned issues or what should be done to rectify these limitations?

By taking various factors into consideration we can increase the efficiency of nano-fluids up to some extent. They can be described as

1. Long term nano-particles dispersion

Stable dispersion of nano-fluid is also one of the challenging jobs. So for this some physical, chemical treatments or some surface modifications can be done. Stabilizers or surface active agents should use to disperse the nano-particles in aqueous solutions [9].

2. By increasing the pressure drop and pumping power in case of heat transfer systems

Cooling is one of the important parameter by which we can determine the efficiency of nano-fluid. by increasing the pressure drop (viscosity and density) extent of heat transfer can be enhanced up to somehow. Lee et al. [10] in case of water based nano-fluid this pressure drops system can be used.

(In this way by highering viscosity and lowering the specific heat we can effectively enhanced the heat transfer capacities of nano-fluids.

By using different nano-fluids an enhancement in thermal conductivity and heat transfer coefficient can be reported by many research groups. As Blake T. Branson reported that when we reduce the size of nano-core thermal conductivity gets increases with temperature, because small solid materials have greater stability and thermal conductivity in base fluid. As addition of less than 1 vol % of nano particles materials gives a double digit percentage enhancement in thermal conductivity in the case of (ND)-poly(glycidol) polymer when used in ethylene glycol base-fluid[2]. in the presence of oleic acid by dispersion in light mineral oil exhibiting the 11% increase in thermal conductivity of nano-fluid. Their surface modifications can also be done by hydrogen bonding interactions at different concentrations by making them stable and static nano-fluids

Effect of volume fraction

Many researchers found for the volume fraction this shows a linear and non-linear relationship in various plot with increase in thermal conductivity. Thermal conductivity mainly affects from temperature and volume fraction generally in many conventional fluids they contains different sized ranged (mille, micro nanometer) particles. Due to exhibition of different motions with in base fluids and their volume fractions thermal conductivity gets affected. Various kind of motion existing with the nano-fluids such as Brownian motion, particles aggregation, suspended solutions and they shows significant changes in thermal conductivity of nano-fluids. When we

take 0.05 vol % TiO₂ nano-particles in de-ionized water, 3% increase found in thermal conductivity with 15% volume fraction gets increase as per reported data. Duangthongsuk et al., Masuda et al. also measured the thermal conductivity at room temperature for these different nano-particles experimentally. Loading of 1% TiO₂ shows effectively 14% increase in thermal conductivity [11].even Al₂O₃ based nano-particles shows an anomalous increase in thermal conductivity reported by recent Benchmark studies [12].

Effect of temperature

Different research groups show their different influence of thermal conductivity with temperature where as some shows increase in thermal conductivity with temperature by using different metal based nano-fluids. An enhancement was found in case of different nano-fluids such as CuO, ZnO, and Al₂O₃ dispersed phase nano particles when are taken with E-G and water as a base-fluids in a ratio of 40:60[68]. In a report of D.K Agarwal et al./ ratio of thermal conductivity increases from 1.23 to 1.30 for 750 Graphene based nano-particles over a temperature range of 20 to 70 degree[13]. The comparative thermal conductivity was found a decrease with the increase of temperature from (15-35) degree for TiO₂ water based nano-fluids [14].

Effect of surface charge and pH on nano-fluids

Surface charge is the basic feature which is responsible for increasing the thermal conductivity of nano-fluid [15]. It is also an important factor which plays a key role in the stability of nano-fluid. In different suspensions particles attracts and repels each other which depends on their interaction energies which is the sum of $E_{att}+E_{rep}$. Donggeun Lee**/ and his co-workers found an increase in thermal conductivity with increase of pH (9-10) and only attraction occurs i.e. repulsion obstruction gets reduced with the increase in pH. Energy of repulsion should be less for smaller sized nano-particles therefore large zeta potential is required [83]. Iso-electric point is the point where the concentration of potential controlling ions varies when zeta potential values are zero. As pH of solution changes from the iso-electronic point, in case of colloidal it makes the stable solutions where as in case of suspensions it automatically transforms the property of thermal conductivity.

Effect of shape of nano-particles

In many past studies it was reported that an enhancement occurs in thermal conductivity ratio with the change in the shape of particle. Cylindrical, blade shaped particles show more conductivity as compared to other shaped [16]. By Zhou and Gao [17] they reported the different spherical and cylindrical shapes of nano particles which shows effective thermal conductivity in comparison to spherical shape nano particles.

Effect of surfactant or additives:

Stability of nano particles in different aqueous suspensions can be enhanced by adding different capping agents, stabilizers, surfactants or additives. Because of using these additives, water hating surfaces becomes water loving (hydrophilic) and vice versa for different aqueous non-aqueous suspensions. Surfactant cause coating which makes electrostatic forces more dominant over repulsive forces. Therefore an increase in surface charge occurs which makes the suspension more stable with different nano-fluids. Many surfactants that can be used are found in literature such as sodium do-decyl sulphate (SDS)[18-19],oleic acid and SDBS[20-21],PVP(polyvinylpyrrolidone)[22],Gum Arabic[23] etc. by choosing different suitable(cationic or anionic) surfactants, suspensions can be make more stable. Philip et al.[24] reported that aggregation is an important factor which passes a heat flow over many distances and enhances the thermal conductivity as well as heat transfer co-efficient of nano-fluid. Basically for gaining the better quality of suspensions particles should be scattered by liquid medium and and also dispersed in liquid medium. Zeta potential is important for making common repulsive forces among the particles that's why additives are added in nano-fluids.

Effect of Sonication

In present studies data reported that different sonications effects the thermal conductivity of nano-fluids. sonication mainly enhance the thermal conductivity and helps in the breaking of large bunch of particles and breaks them into smaller form. As different types of particles present in nano-fluids so they choose different pathways because as initially after sonications thermal conductivity increases and decreases with the passage of time. Large aggregations of particles results the decrease in thermal conductivity. There can be various other methods that can be used for making suspensions stable proposed by hwang et.al in which two micro channels are consisted of different streams. Both streams are combined to make the particles of nano-fluids

more stable. Breaking the clusters of nano-particles was studied by high energy cavitations [25]. Clusters of particles can be broken by various methods

- 1) By exploding the energy of induced cavitations.
- 2) By irregular shocks on inside interaction chamber.
- 3) By high shear rate of flow (important from engineering aspect).

2.3 Mechanisms for thermal conduction in nano-fluids

The thermal conduction mechanisms in solids, liquids and gases which mainly tell about the thermal behavior of materials or particles are as:

Free electron, Phonon and Photons carries heat in all of the materials [26]

So, the net thermal conductivity is

- $\kappa_{el} = 0$ for insulators
- $\kappa_{phon} \approx 0.01 \kappa_{el}$ for metals
- κ_{phot} : significant only in transparent materials (glasses, ceramic single crystals) and at moderately high T ($> \sim 700$ K).

A general model

Goal of a “microscopic” description: to understand what determines κ and its temperature dependence. For each mode of thermal conduction [27]

$$\kappa = \frac{1}{3} c_v v \delta \quad (20)$$

c_v : heat capacity of the “thermal carriers” per unit volume

v : velocity of the carriers

δ : *mean free path* — distance between carrier collisions

Mean free path definition

Phonons and electrons are scattered by disruptions in the periodicity of the lattice:

- Other phonons — κ_{phon}

- Intrinsic defects (vacancies, self-interstitials) — δ_{int}
- Impurities — δ_{imp}
- Line defects (dislocations) — δ_{dis}
- Planar defects (e.g. grain boundaries) — δ_{gb}

δ_{gb} \propto grain size

Each scattering mechanism presents its own resistance to heat flow[903]

$$\frac{1}{\delta} = \sum_i \frac{1}{\delta_i} = \frac{1}{\delta_{phon}} + \frac{1}{\delta_{int}} + \frac{1}{\delta_{imp}} + \frac{1}{\delta_{dis}} + \frac{1}{\delta_{gb}}$$

(21)

δ_{gb} is dominated by smallest δ_i :

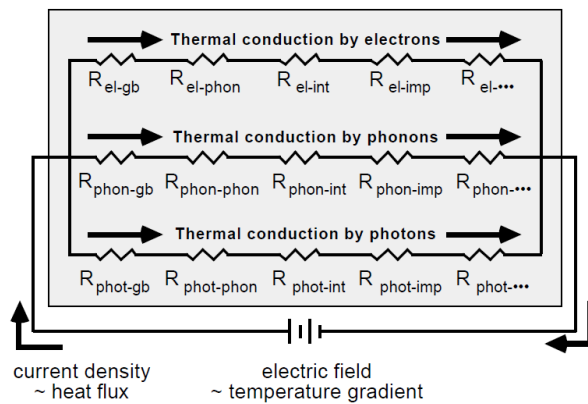

Figure 2.2.1 Thermal conduction mechanisms and networks

Cryogenic Thermal Conduction [28]

Widely divergent values of thermal conductivity for the same material are often reported in the literature. For comparatively pure materials (like copper), the differences are due mainly to slight material differences that have large effects on transport properties, such as thermal conductivity, at cryogenic temperatures. At 10 K, the thermal conductivity of commercial oxygen free copper for two samples can be different by more than a factor of 20 while the same samples at room temperature would be within 4%. It is also not uncommon for some experimental results to have uncertainties as high as 50%. Part of our program is to critically evaluate the literature to

determine the best property values. Data references used to generate predictive equations will be reported.

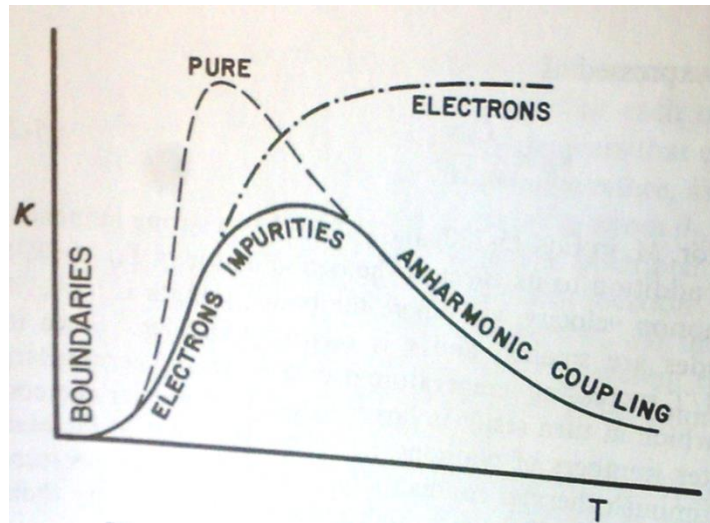

Figure 2.2.2) General behavior of the thermal conductivity of materials

2.4 Various Characterization techniques

The prepared Nano-particles were characterized by using different techniques for measuring their various properties such as size, surface charge, structural morphology, absorption, chemical composition and thermal stability etc. In this research work various techniques were used to characterize the nano-particles and to measure their thermo-physical properties such as thermal conductivity and heat transfer coefficient. They are as following:

U.V. visible spectroscopy

Fluorescence spectroscopy

Dynamic light scattering (DLS)

Scanning electron microscope (SEM)

Transmission electron microscope (TEM)

U.V. visible spectrophotometer (UV-vis spectrometer)

In this after passing the light from sample it was done for U.V. visible. This kind of spectroscopy mainly predicts about the absorption ranges of nano particles and their band gaps. This is based on the principle when sample is manifested to light (acquiring threshold energy for activation) within the molecule for transition of molecules from lower to higher energy states. Analytic Jena, SPECORD 205 U.V. *vis* spectrophotometer was used in this research work for determining the characteristics of absorption band for synthesized nano particles of TiO₂, Ag-Si Based etc. this spectroscopy refers to absorption spectroscopy in U.V. region. It means it uses the light in U.V. as well as visible up to in adjacent ranges. This technique is routinely used in the analytical chemistry work for quantitative determination of different samples [29].

Fluorescence Spectroscopy

It is defined as a kind of spectroscopic technique which analyze the fluorescence from the sample and sometimes also called as fluorimetry. In this analysis usually a beam of light (U.V. light) which excited the electrons from the molecules of many compounds and makes them to emit the light. Molecules have many energy levels concerned of electronic and vibrational channels along with different energy states. In this mainly first sample is analyzed by absorption of photons from its ground state to its next excited state and to further or many vibrational levels. The process is mainly defined on the basis of Jablonski Diagram [30].

There can be various types of instruments present to measure fluorescence such as fluorometer, monochromator [96] etc.

In this work we have used a quartz cuvette for sample holding into the instrument and data interpretation was done in nano material lab (Department of Chemistry, Thapar University, and Patiala). It is always necessary that in sample there must be some absorption properties in the fluorescence absorption range.

DLS (Dynamic Light Scattering)

This instrument is mainly used for determining the size of particles of various ranges. It is mainly used for nano particles, polymers, micells solutions etc. in various purposes. In DLS, measurement mainly depends on size of particles, core size and surface charge acquired by

particles on different concentration. DLS mainly measures fluctuations in scattered light intensity due to different diffusion coefficients which can also be determined. DLS software mainly predicts the particles population and different diameters [28].

In this work nano particles were taken in approximately of 1.5 ml cuvette in the form of dispersed phase.

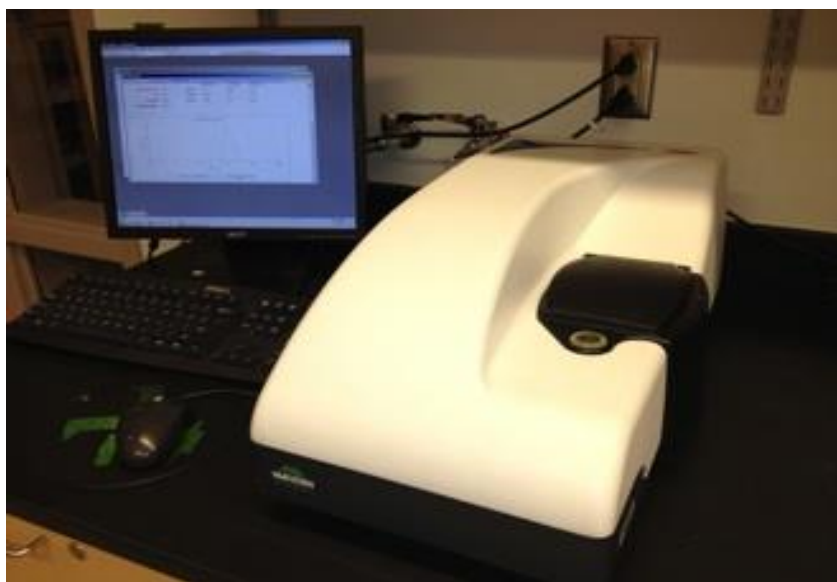

Fig (2.4.1) shows the instrument of Dynamic Light Scattering

SEM (Scanning Electron Microscope)

This instrument is basically used for determining the surface morphology of particles. The information about crystallographic, chemical composition can be obtained from the SEM images. The principle of it is a beam of electrons is bombarded over the particular area of sample at the time of analysis. The beam of light exchanges at the surfaces of sample In the form of energies. In this work JSM-7600 F (0.1 to 30 KV). Instrument was used for SEM images interpretation In SCI labs (Thapar University, Patiala). During the analysis of samples they were placed on a specimen with conducting tape and further coated with a thin layer of gold for making it conducting.



Fig (2.4.2) shows the instrument of SEM by through data analysis have done

EDS (Energy Dispersive Spectroscopy)

This is also one of another type of spectroscopy technique which is basically used for elemental detection and chemical composition. All samples were analyzed by energy dispersive spectrophotometer. EDS is also very beneficial about to recognize the sample contamination and for the concentration on the surfaces. In this work EDS was done on JEOL JSM-6510LB (SAI Lab, Thapar University, and Patiala).

TEM (Transmission Electron Microscope)

From this transmission technique we can see even very smaller column of atoms, having smallest resolvable objects in this light microscope. This forms a major analysis method in various fields such as in scientific, in physical, chemical and biological sciences in today's world. This technique is mainly used to optimize the more resolve images of sample or what product we have synthesized. Basically it provides the clearest pictures of particles and their sizes and shape interpretations. This is mainly based on the principle that when a beam of light falls on the samples and its gets transmitted, and due to this they forms a magnified and focused image on detecting device. Now days HR TEM is more beneficial technique to get clearer image pattern of the samples. In this work analysis were done of HR TEM from Sprint Testing laboratory

(Mumbai) for making the research work more valuable. In this suspended solutions of all the samples were dropped over a copper grid having a coating of carbon and then investigated. Various others imaging methods can be used for analysis such as diffraction, contrast formation, and 3-d imaging etc.

KD2 pro thermal properties analyzer:

This instrument was used for measuring the thermal-conductivity in our research work. There are three types of thermal conduction such as by convection, diffusion and direct conduction. This is based on convection in which a needle acts as heater and temperature sensor and when it senses the temperature from heater and it gives the value of thermal conductivity on screen of KD2 pro. In this way analysis can be done for different types of fluids up to a suitable range.



(Fig (2.4.3) shows the instrumental of Kd2 Pro Thermal Conductivity Analyzer)

Research Gap

Literature reviews predicts that many factors along with different parameters such as viscosity, volume fraction, concentration, effect of aggregation of particles, size and surface area and their geometric morphology etc. affects the thermal conductivity. Other thermo physical properties such as heat transfer co-efficient which also shows changes in nano-fluids suspensions with the effect of these basic parameters. By using different nano-materials of various metals, oxides etc. it can be expected their thermal conduction, heat transfer properties can be improved up to some

extent. So by this for better conduction of thermal conductivity we can think to synthesize some material in the form of nano-fluid which can be used to improve their efficiencies with the change in different thermo physical parameters. One of the major problems among this is to maintain the stability of suspensions of various nano-fluids of different concentrations. As in there is a strong Vander walls force of interactions occurring which cause the formation of clusters of particles within the base fluid. Many experimental trials were made to overcome this problem by varying pH and using additives etc. however it comedown the thermal conductivity radially due to chemical interactions and co-angulations of nano-particles with the passage of time. Why we need to choose a material which consists of thermally insulated as well as conducting properties. There can be various materials which can be used for this purpose found from literature such as:

Material name	Properties	Advantages
Quasi 1-d metal oxide	Semiconductor(chemical sensor)	Can acts as floating material
Boron-nirides	Semi-insulating material	In the form of nano-tubes
Thiophene based(Ga-As based)	Conductor	Controls over heating in heat transfer systems and high di-electric constant
Silica(insulator)	Provides natural insulations	Cheap to use
Ni catalyst	Beneficial in Semiconducting	Can work as metal oxide form as a floating type

Table 2.4.4shows a collection of some materials which can be used as core shell

So there is a need to improve the stability of nano-fluids to measure the thermo-physical properties for future applications. In many stabilizers silica is also stable at room temperature and thermally inert which can be easily used in various heat transfer systems as well as in cooling and high voltage systems.

Chapter 3 Experimental work

3.1 Chemicals

Titaniumisopropoxide[(Ti(OCH₃)₂)₄],TiCl₄,ethanol(C₂H₅OH),sodiumhydroxide(NaOH),nitricacid (HNO₃),methanol,TiO₂ P-25 and de-ionized water, sucrose, PVP solution

3.2 Synthesis of TiO₂ nano-particles

TiO₂ nano-tubes and nano-rods were synthesized by hydrothermal method [94] by TiO₂ P-25. In this experiment 2 g of TiO₂ P-25 was taken in 50 ml of NaOH(10N) and stirred with glass rod for half an hour, then it was autoclaved at 130 degree for 20 hour on muffle furnace. Slurry of this mixture was prepared with 0.1N nitric acid and washed with de-ionized water and methanol. Now sample was dried for overnight at 80 degree in an oven.

TiO₂ nano-tubes were used to synthesis of TiO₂ nano-rods and they mixed with 40ml DI and maintained the pH at 5-6, further sample was washed with methanol and dried for 48 hours at 175 degrees.

3.3 Synthesis of silver-silica nano-particles by reduction method

In this method 3.4g of silver nitrate salt was taken in 20ml de-ionized water. Then by dissolving 0.2g of PVP in 25ml the solution was prepared and adds into 0.01N NaOH in 60 ml de-ionized water and stirred the solution together and heat it at 40 degree and add into silica solution of nano-particles drop wise by stirring and kept for 20 minutes .Now add nitrate solution drop wise into it and stirred it for 10 minutes. Particles were separated by Ultra centrifugation and the product was washed with de-ionized water.

3.4 Preparation of nano-fluids:

There can be various method used to prepare the nano-fluids such as single step and two step method.

1) In two step method nano-particles are first synthesized and then add into any suitable base fluid such as ethylene glycol and water.

2) In single step method both steps can be done simultaneously within the base fluid and sonications can be done for dispersion of nano-particles.

3.5 Different characterizations techniques used and interpretations of results

Size and Structure morphological interpretations

We kept the sample for 1 day after drying the sample was dissolved into ethanol. By DLS method we characterize it and data reported for the TiO₂ nano-particles. In the figure () DLS pattern shows a size range which comes out to be 50nm in average for the TiO₂ nano-particles

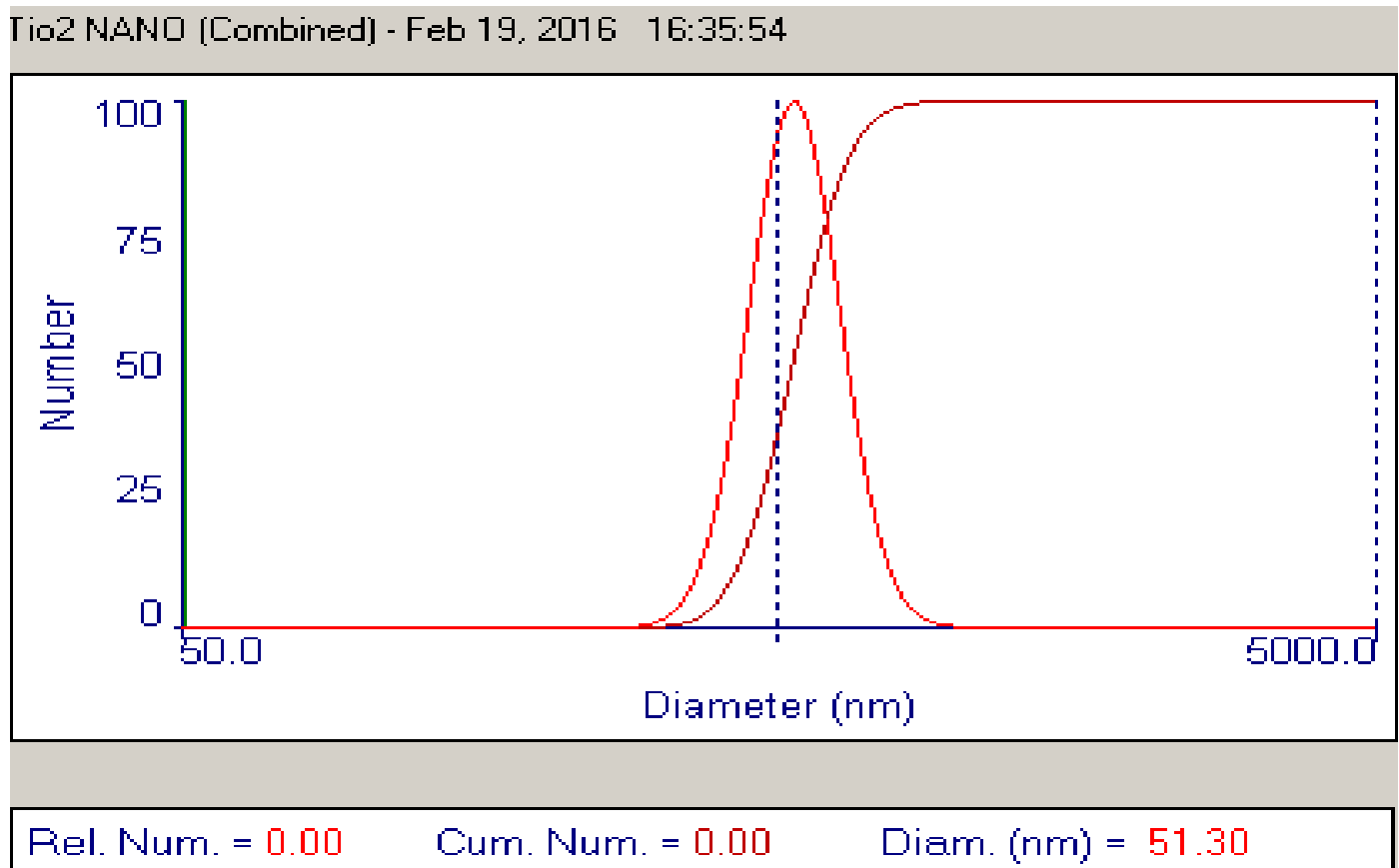

(Fig 3.5.1 shows DLS pattern for TiO₂ nano-particles)

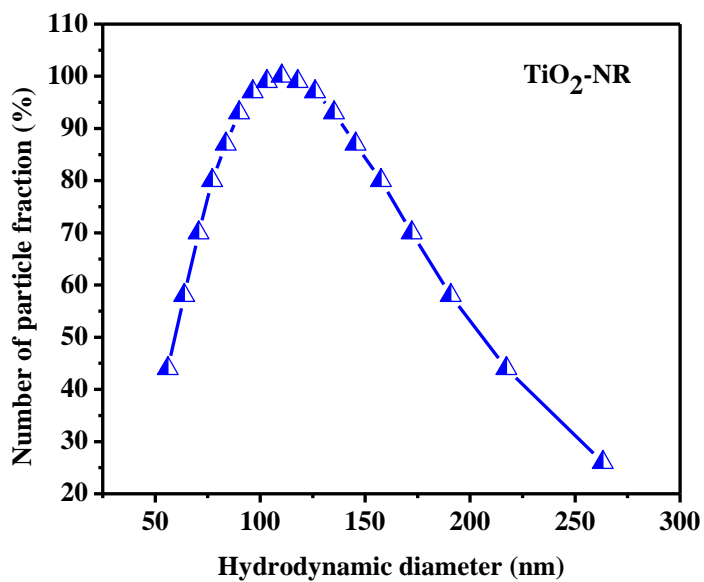

(Fig 3.5.2 shows the DLS plot for TiO₂ nano-rods having 100nm average diameter)

This above data predicts about the specific average size statistics and peak intensity distribution.

By fluorescence

This is also one of characterization technique which was used in this work, which shows peak intensity of absorption for TiO₂ nano-particles.

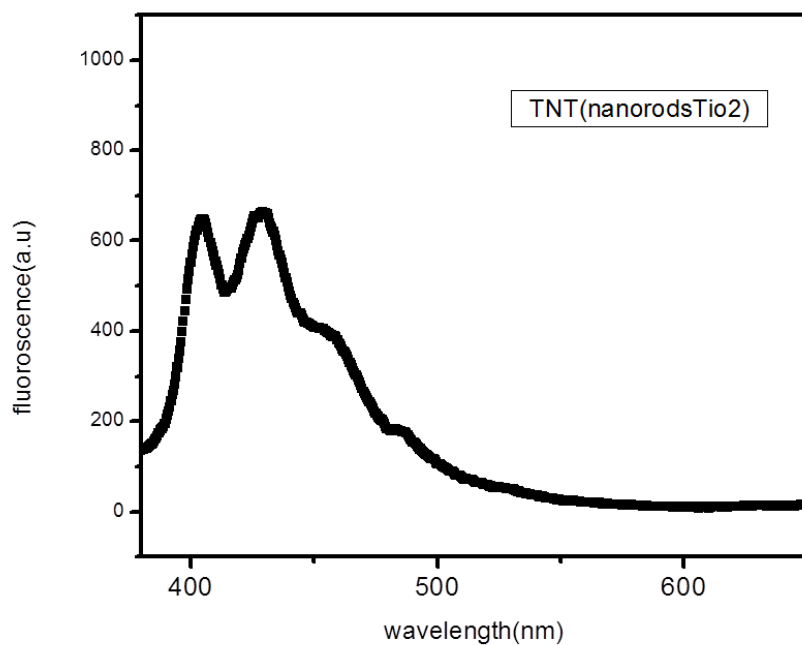

(Fig 3.5.3 shows fluorescence peak intensity for TiO₂ nano-particles)

Above pattern explains the peak intensity distribution which shows a range of (400-700 nm) for these synthesized nano-particles.

Characterization of silver silica based nano-particles by DLS

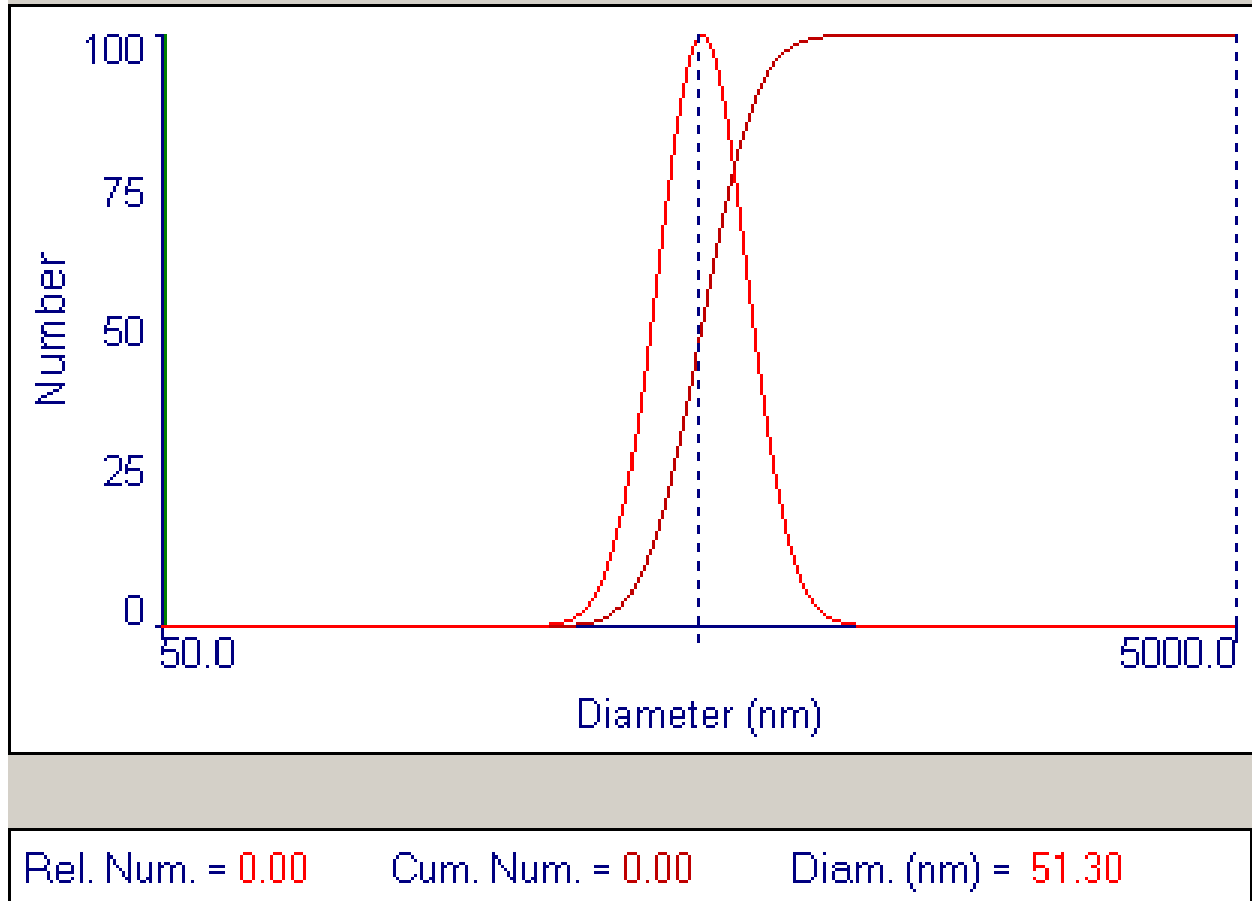

(Fig 3.5.4 shows size distribution of silver coated silica nano-particles)

By SEM-EDS results

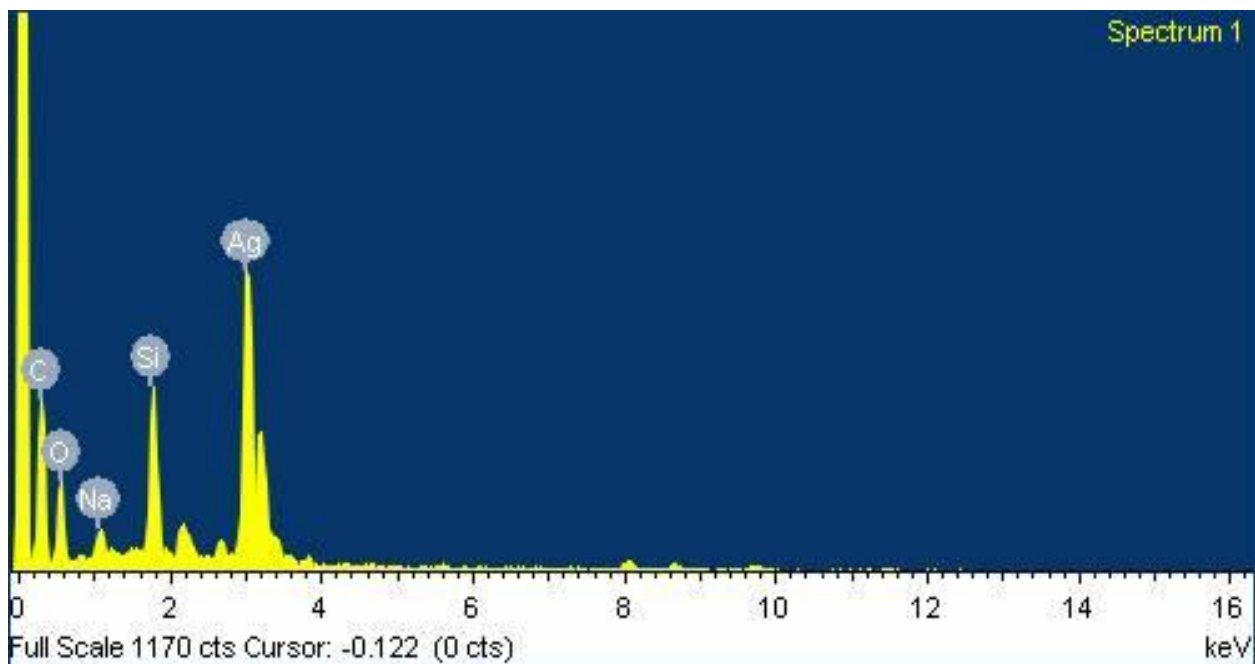

(Fig 3.5.5 shows the EDS results and composition of silver and silica in nano-particles)

SEM data interpretations

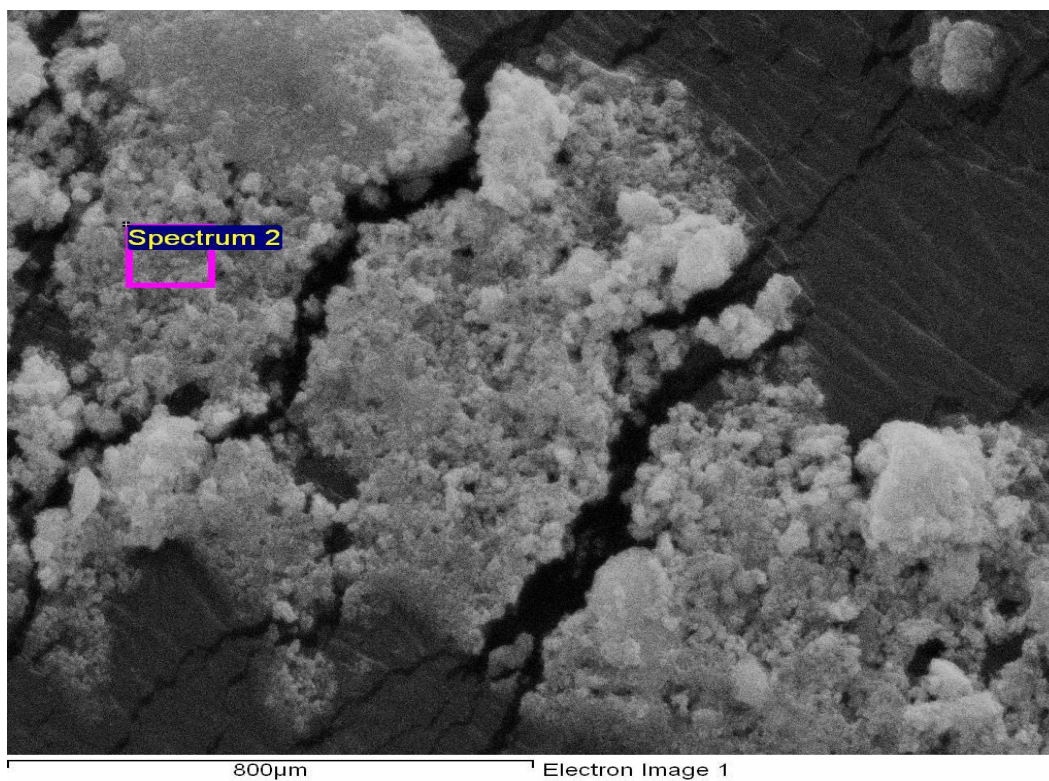

(Fig 3.5.6 shows the SEM images of silver coated silica nano-particles)

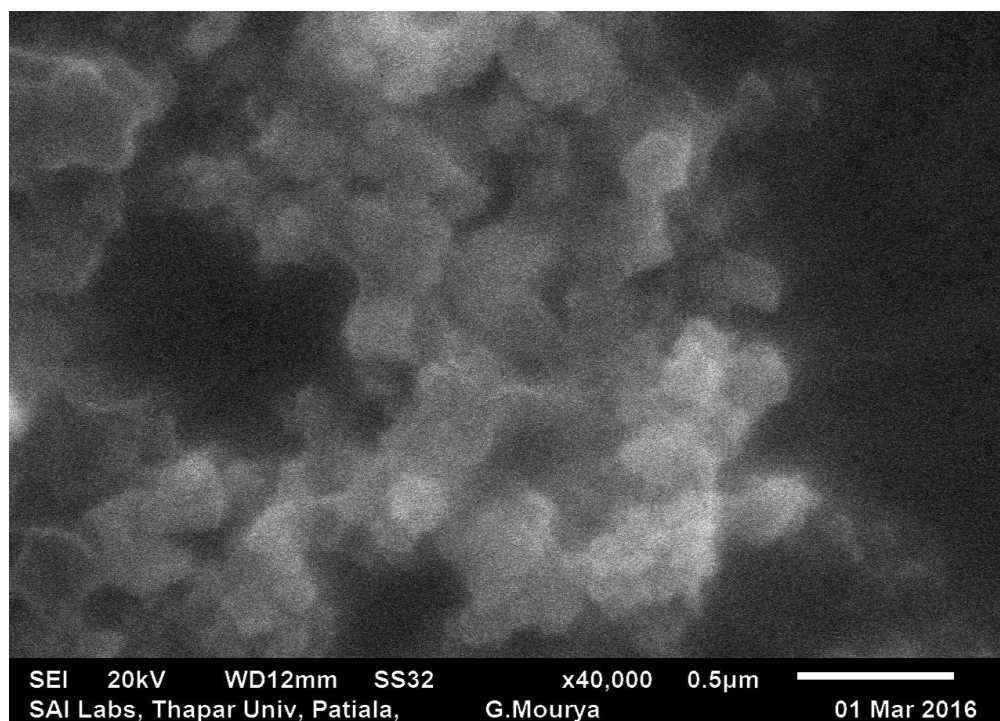

(Fig 3.5.7 shows More resolution image of Ag-Si)

In figure (3.5.3) EDS images shows the percentage composition of silver coated silica based nano-particles. On the other side figure (3.5.7) shows SEM images which have some irregular clusters of silver coated silica based nano-particles having average size almost 50 nm.

It has been found from SEM images there is a difference in surface area of synthesized nano-particles due to their different morphologies, because higher surface area forms a hollow spherical shapes. In the above images of SEM, shows some oxidation due to presence of silver which makes clusters of particles somewhere. Finer images can be collected and can be analyzed by HR TEM. In the spectrum shows a particular portion of nano-particles which tells about the irregular shapes of nano-particles.

3.6 HR TEM interpretations of silver coated silica nano-particles

The HR tem images in figure (3.6.1) shows some irregular and spherical shapes of silver coated silica nano-particles core shell structures which is mainly consists of a core shell of silica coated

with silver nano-particles. The difference in surface area was found due to different irregular shapes of prepared nano- particles.

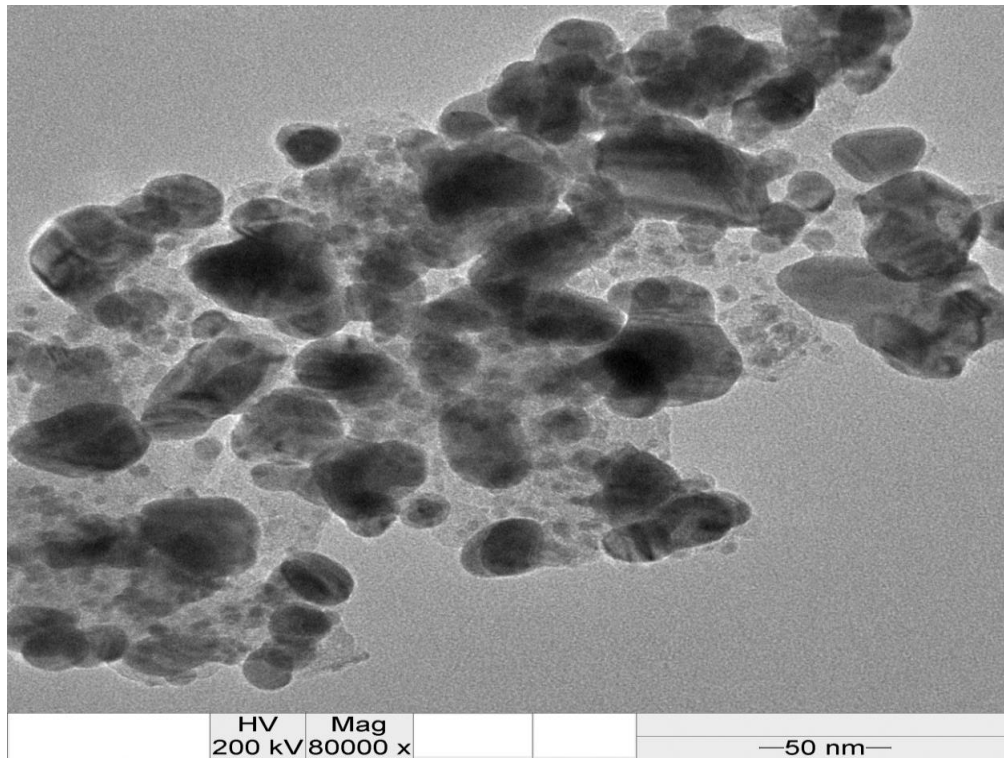

(Figure 3.6.1 shows HR TEM images for silver coated silica nano-particles)

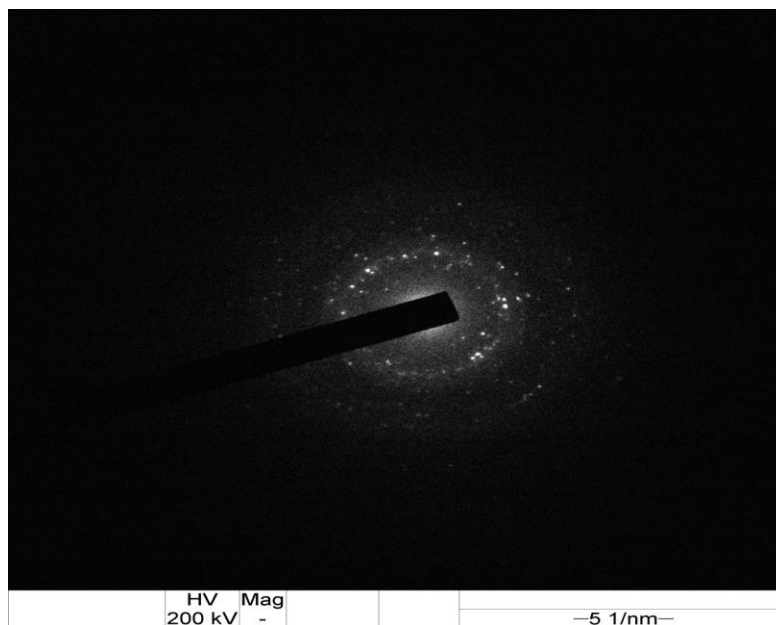
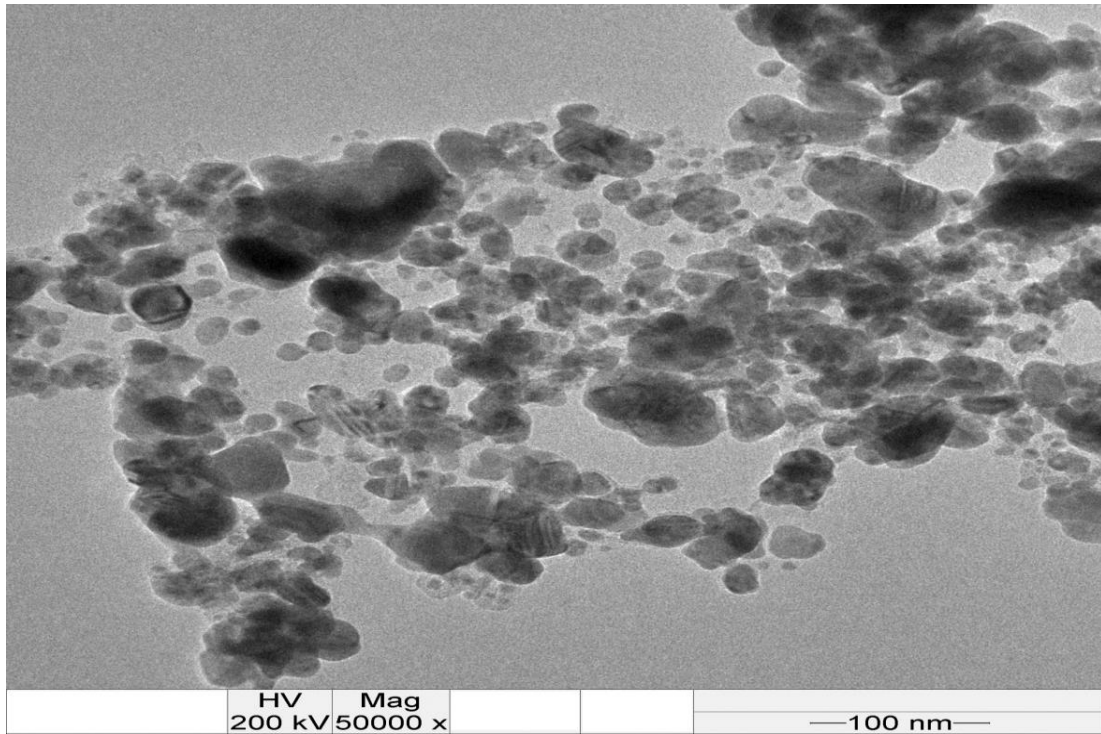
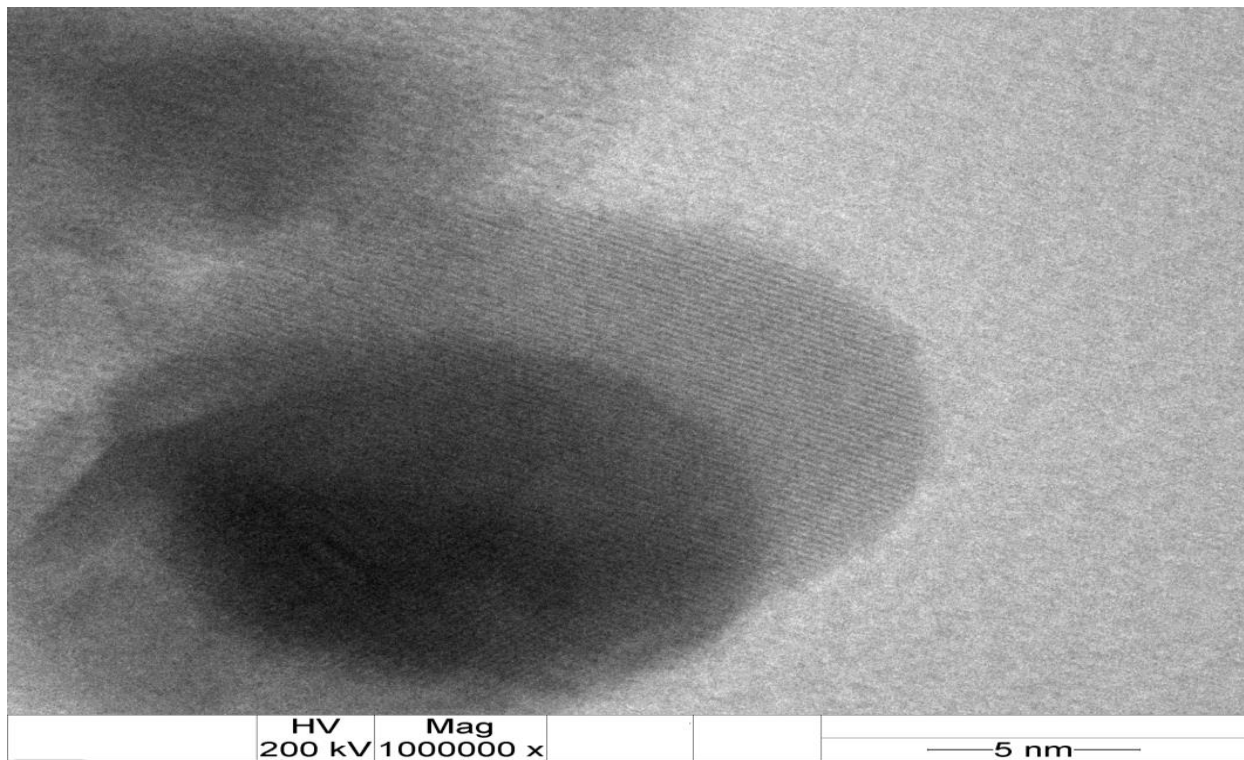

Fig (3.6.2) shows TEM crystalline morphologies of nano-particles having 51nm diameter



Images (3.6.3) shows different irregular shapes of silver silica nano-particles by HR TEM



Very high resolution HR TEM image for size range up to 5nm

The above all HR TEM images predicts about the different ranges of nano-particles.in this research work whole interpretation was done by HV (200kV) Mag(1000000) HR TEM(Sprint Bombay).in this synthesis of silver coated silica nano-particles synthesis.

Chapter 4

4.1 Thermo physical properties measurement

Thermal Conductivity Measurement

Heat Transfer Co-efficient

Thermal Conductivity Measurement

For determining the thermal properties of nano fluids the KD2 Pro (Decagon Devices, USA) instrument was used. In this work KS-1 sensor needle was used for measuring the thermal conductivity which is made up of stainless steel having the length of 60mm with 1.3mm diameter. The main fact with this instrument is the needle should give the least disturbance to sample during analysis. The correctness in measurement of thermal conductivity by needle is 5-6% in range of 0.3-3 w/m.k which is similar up to the ASTM56 and IEEE57 standards.

During the experiments with this KD2 Pro the needle was kept into the 15 ml sample tube vertically. The readings were taken after a 15 min gap over a period of time at different concentrations. The set of instrument automatically works with the interval of time at different temperatures for each sample. First sample was calibrated with the base fluid such as de-ionized water and ethylene glycol which already have some standard values of thermal conductivity, 0.280w/m.k for EG.

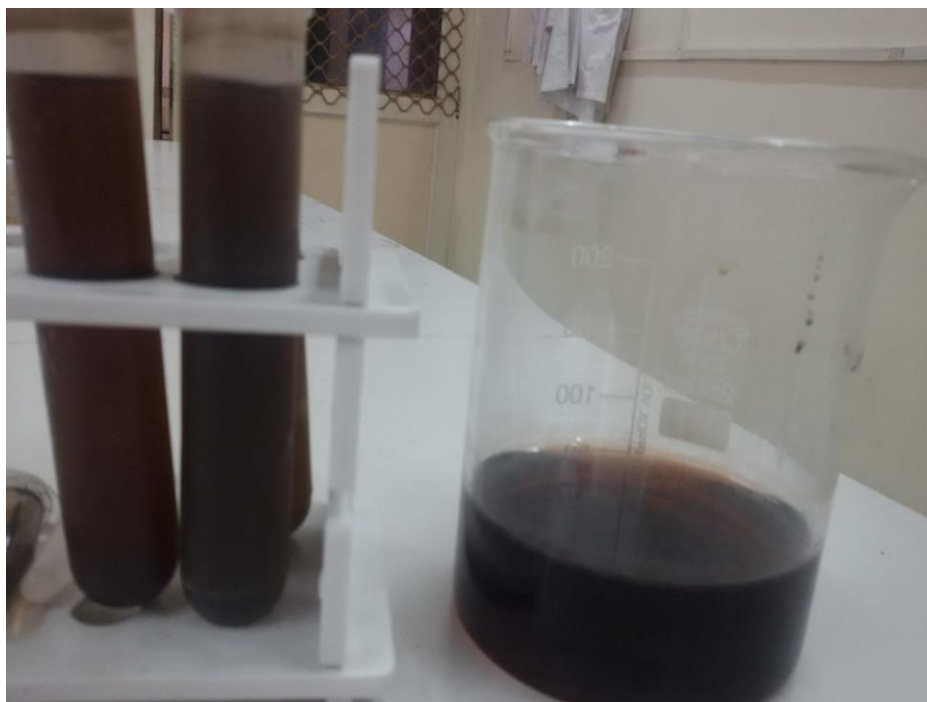

Fig 4.1.1 shows the dispersion of silver-silica nano-particles in EG base fluid

At various concentrations with different samples at temperature range (25-40°C) experiments was performed with it. Silicon oil bath was also used as temperature controller for measurement of thermal conductivity. The experimental setup is shown



Fig 4.1.2 shows KD2 thermal properties analyzer set up with TIO2 nano-fluid

Thermal conductivity results of silver coated silica nano-particles

Thermal conductivity values of Ag-Si nano fluids (base fluid ethylene glycol and water) for different concentrations (0.01g) by KD2 pro:

Temperature(in degrees)	Reading	Error
25.59	0.271	0.0032
24.89	0.279	0.0056
24.08	0.251	0.0031
25.59	0.291	0.003

For 0.02 g in 15ml

Temperature	Reading	Error
26.48	0.341	0.0038
23.71	0.330	0.0043

25.71	0.345	0.031
24.89	0.364	0.0021

For 0.03 g in 15ml

Temperature	Reading	Error
24.94	0.293	0.0031
24.08	0.312	0.0045
25.91	0.330	0.0046
25.41	0.341	0.0048

For 0.04g in 15ml

Temperature	Reading	Error
25.10	0.312	0.0056
25.75	0.293	0.0031
24.91	0.303	0.001
25.05	0.345	0.0038

Table 4.4.1 shows the various values of thermal conductivity

Temperature	K as per KD2 pro
25	0.611
	0.642
	0.644
	0.641
30	0.612
	0.643
	0.621
	0.444
35	0.899
	0.871
	0.888
	0.899

40	1.164
	1.072
	0.873
	0.871

Table 4.1.3 shows the average values of thermal conductivity at different temperatures

Influence of volume and thermal conductivity on AG coated Si based nano-particles

When we plot a graph between thermal conductivity and concentration then it shows a curve shown in fig (4.4.3.1). This whole predicts that on increasing the concentration of sample it increases up to some extent. The percentage increment can be calculated from the mean values of thermal conductivity given in above table. From the figure (4.4.3.2) we can demonstrate that Ag-Si based nano-fluids shows always higher thermal conductivity than others due to the presence of Ag coating.

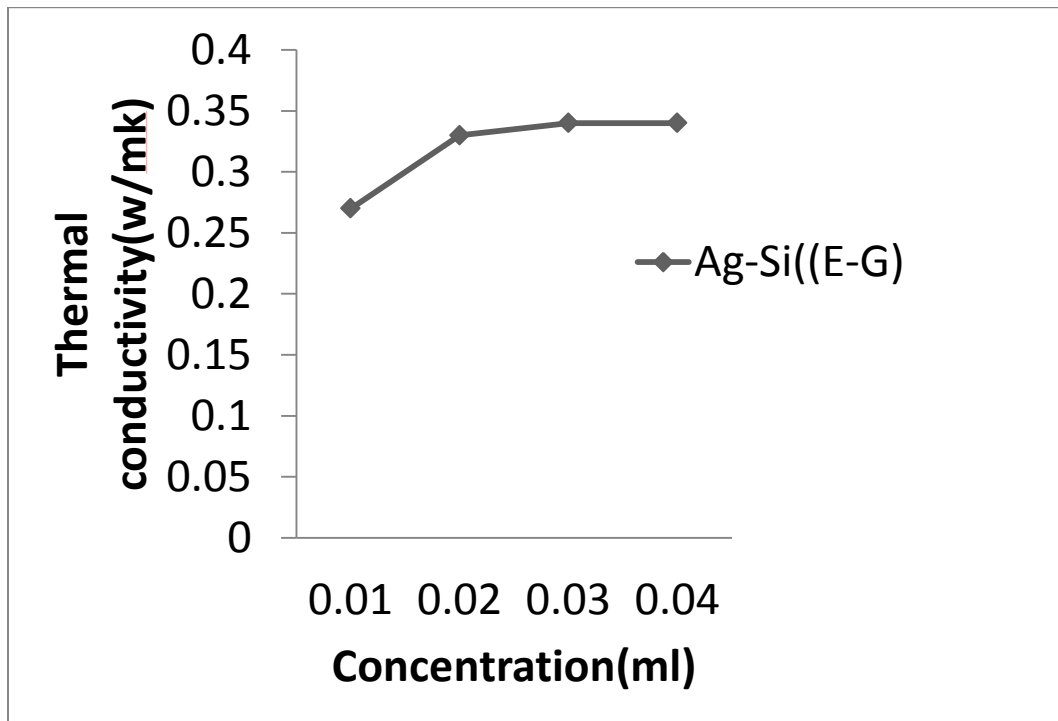

Fig (4.1.4) shows variation of thermal conductivity with concentration

Plot (4.1.4) shows only experimental curve for base fluid (EG) which nearly comes out to be 0.248w/m.k at various temperatures. This demonstrates about the experimentally measured thermal conductivity values for silver coated silica nano-particles.the thermal conductivity value increases with the increase of temperature and enhancement occurs up to 12%, 16% for 0.15% and 0.60% volume concentration respectively. In this main observations were done with EG nano-fluid and repeated experiments were done with DI.

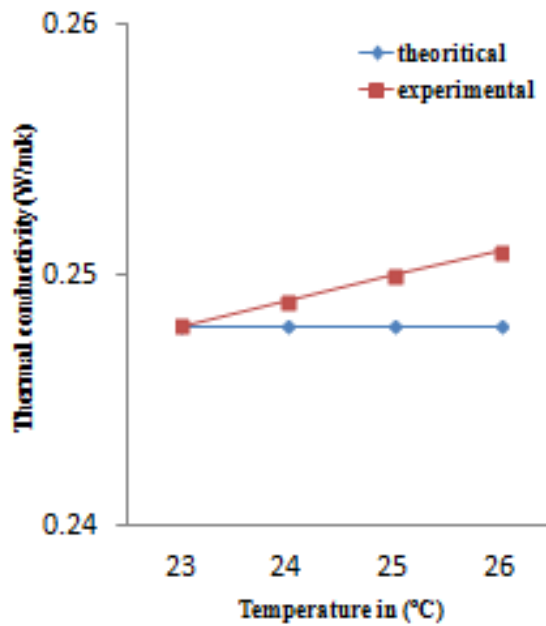
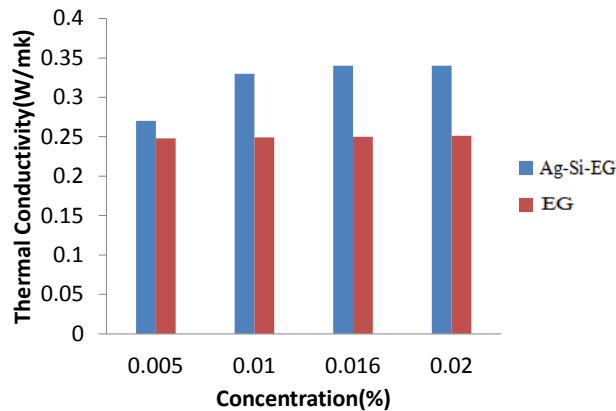

Fig (4.1.5) shows the plot of thermal conductivity of base fluid (EG)



The above plot (4.1.6) shows about the ratio increment in thermal conductivity w.r.t base fluid.

4.4 heat transfer co-efficient measurement

Double Tube Heat Exchanger

Heat transfer co-efficient was calculated by double tube heat exchanger in which double pipe heat design is an important factor in flow pattern. With this simplest instrument experiment was performed in heat and mass transfer lab (department of mechanical engineering). In double tube heat exchanger heat flow can be in both directions parallel or anti-parallel with a mean difference of temperature.

By measuring heat transfer co-efficient, surface area and pipe-length etc can also be measured. It consists of various components such as:

Pump

A device which is used to move slurries, fluids by mechanical work of action and can be of different types such as direct lift, displacement and gravity pumps.

PID (proportional-integral derivative controller)

This mainly helps to predict the error comes between the desired set point and detected process variables.

Rota meter

It is an apparatus which measures the rate of flow of fluid in a closed tube and fluid moves to vary the measurable effect. In our work the simple configuration has been taken of this double pipe heat exchanger which consists of one pipe inside and another larger pipe fluid was shown through the pipe in counter directions. The inner wall of heat exchanger acts as heat transfer surface.

Major calculations about this can be done by basic heat exchanger equation $Q=U_a \cdot \Delta t_{lm}$

Where Q = (rate of heat transfer)

U = (heat transfer co-efficient)

A = (area of heat transfer surface)

ΔT_{lm} = (log mean temperature difference)

As we have used in this is hot water pipe with diameter-6mm and made up of copper whereas for cold water pipe is of 12mm.

Positive rate of flow=heat transfer increases

Negative rate of flow=pressure drop work input increases.

Calculations: For heat transfer co-efficient

Heat lost by hot fluid

$$Q_h = m_h c_p (t_{h1} - t_{h2})$$

Heat gained by cold fluid

$$Q_c = m_c C_p (t_{c2} - t_{c1})$$

$$Q = Q_H + Q_c / 2$$

Average heat transfer in terms of HTC:

$$Q_{avg} = hA * LMTD \text{ (logarithmic mean temperature difference)}$$

$$\text{i.e } h = Q / (A * LMTD)$$

$$LMTD = (t_{h1} - t_{c2}) - (t_{h1} - t_{c1}) / \ln (t_{h1} - t_{c2}) / (t_{h1} - t_{c1})$$

$$\text{For \% increment } h_1 - h_2 / h_1 * 100$$

Heat exchanger instrument used:



Fig (4.4.1) shows the working design of double tube heat exchanger



Fig 4.4.2 shows the working system of cold and hot water pipe in heat exchanger

Hence the above figures show the simplified images of heat exchanger for measuring the heat transfer co-efficient.

Data Interpretation for heat transfer co-efficient

Heat lost by hot fluid

$$Q_h = m_h C_p (t_{h1} - t_{h2})$$

Heat gained by cold fluid

$$Q_c = m_c C_p (t_{c2} - t_{c1})$$

$$Q = Q_H + Q_c / 2$$

Average heat transfer in terms of HTC:

$$Q_{avg} = hA * LMTD \text{ (logarithmic mean temperature difference)}$$

$$\text{i.e } h = Q / (A * LMTD)$$

$$LMTD = \frac{(t_{h1}-t_{c2})-(t_{h1}-t_{c1})}{\ln(t_{h1}-t_{c2})/(t_{h1}-t_{c1})}$$

For % increment h_1-h_2/h_1*100

Table (4.4.3) of Heat Transfer co-efficient at different concentrations (1g, 2g, 3g, 4g) at 40degree

Mass flow rate	Temp(T ₁)	T ₂	T ₃	T ₄	H(heat transfer co-efficient)
1 lpm	30.0	30.1	30.5	30.1	0.434213
2 lpm	41.7	43.7	43.5	43.8	0.874734
3 lpm	30.8	32.7	32.6	32.9	0.837547
4 lpm	47.7	47.2	46.0	47.0	1.184204

Mass flow rate	Temp(T ₁)	T ₂	T ₃	T ₄	H(heat transfer co-efficient)
1lpm	30.1	30.1	30.4	30.5	1.436834
2 lpm	41.2	40.3	42.6	42.1	1.660189
3 lpm	32.8	33.5	33.2	33.8	1.532973
4 lpm	47.7	47.2	46.3	47.0	1.745036

Mass flow	T ₁	T ₂	T ₃	T ₄	H(heat
-----------	----------------	----------------	----------------	----------------	--------

rate					transfer co-efficient)
1 lpm	30.1	30.1	30.4	30.5	0.951921
2 lpm	42.1	41.9	42.4	42.5	1.594468
3 lpm	34.8	34.2	34.1	34.0	1.219051
4 lpm	47.7	47.2	46.3	47.0	1.79026

Experimental Graphs for heat transfer co-efficient

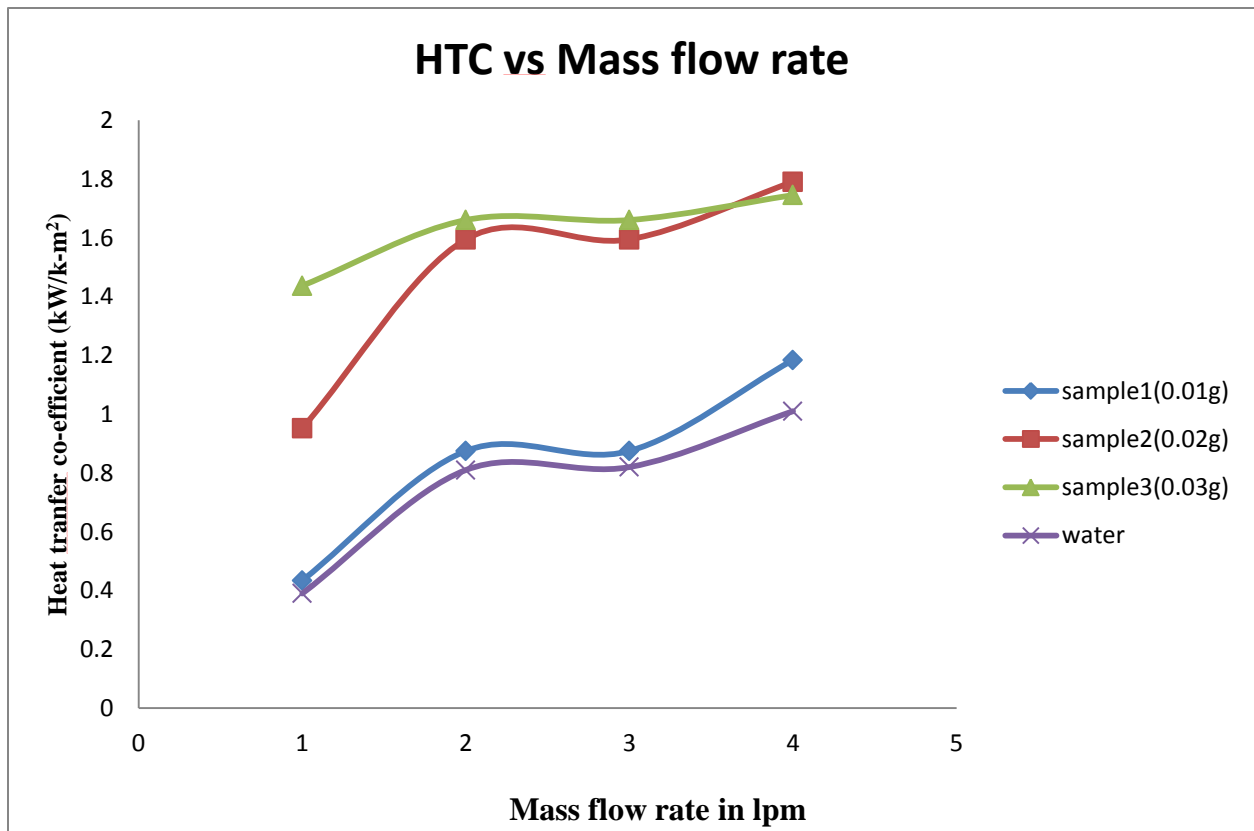

Fig (4.4.4) shows variation of heat transfer at different mass flow rate

The above test was evaluated for measurement by conducting test with water as a coolant in double tube heat exchanger. The experimental results show Ag coated silica nano-fluids give the enhancement in heat transfer.

$$\text{Percentage enhancement} = \frac{\text{Nu}_{nf} - \text{Nu}_{bf}}{\text{Nu}_{bf}}$$

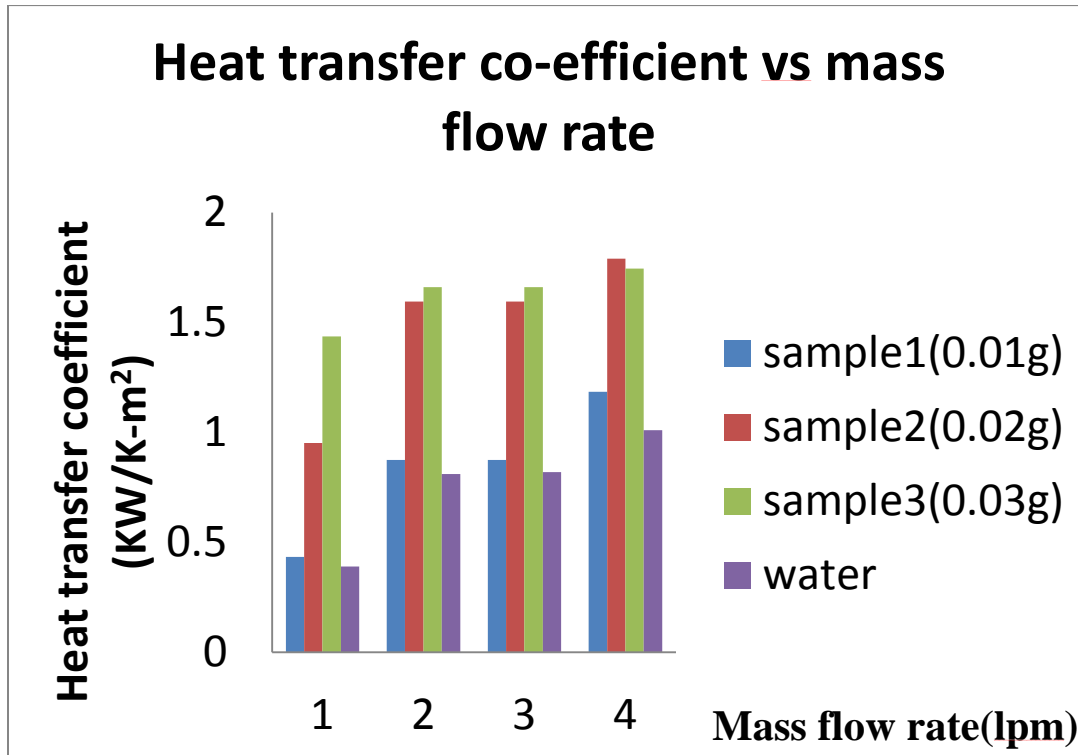

Fig (4.4.5) Graph shows increment in comparison to base fluid water

From above fig (4.4.4) it can be shown the increase in concentration of nano-particles heat transfer increases due to collision in between the nano-particles with the wall of heat exchanger. This leads to increase in Brownian motion and particles migration which results the increase in heat transfer. This heat transfer enhancement occurs 0.45%, 0.15%, 1% at different volume fractions respectively in comparison to water.

So this shows the higher thermal performance because of higher heat transfer co-efficient.in heat exchanger compared to water which causes the improvement in cooling performance of heat exchanger.

Chapter 5

5.1 Schematic of heat transfer and double tube heat exchanger

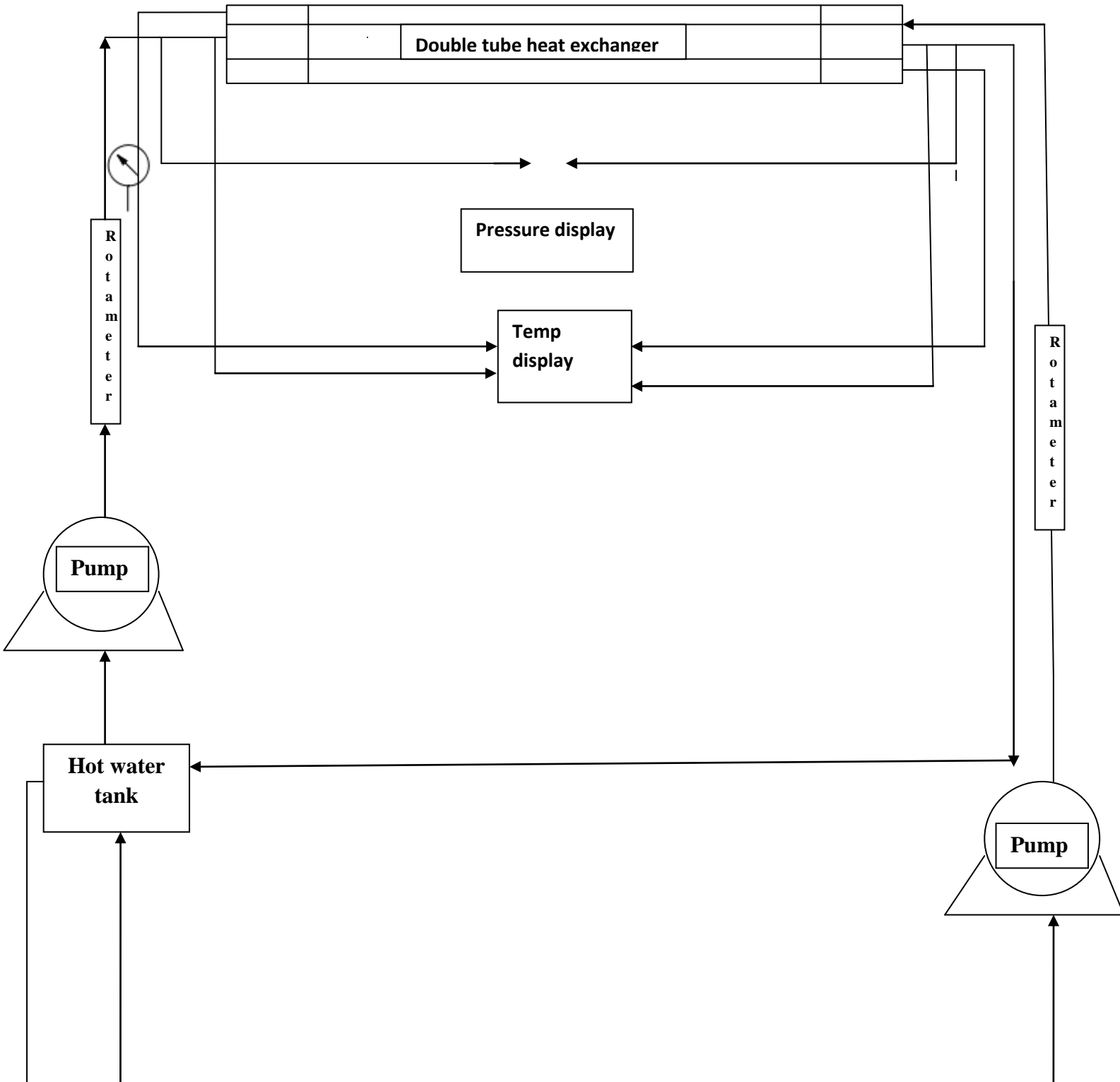

Conclusions

In nutshell, different shapes of nano-particles were synthesized. In this mainly silver coated silica nano-particles were made and (40%-45%) thermal conductivity and (10-15%) heat transfer coefficient enhancement were found with (3-8%) volume fraction.

In this due to small inter particle distance, high surface and molecular compactness. It always shows higher thermal conductivity and heat transfer. Ethylene glycol and water are better base fluids which are observed from experimental part. So this is essential for many cooling applications.

Improvements

By this work some good results has come into existence, but there is a need of improvement by some other techniques for beneficial effect. Thermal conductivity enhancement can be further increased by increasing volume fractions.

Future scope of work

- 1) Enhancement in thermal conductivity of nano-fluid can give many industrial applications in various fields.
- 2) Heat transfer co-efficient enhancement by nano-fluid can improve the heat transfer purposes in various mechanical (cooling systems) as well in engineering fields.

References

- [1] Serrano E, Rus G, Martínez JG. *RenewSust Energy Rev* 2009;13(December (9)):2373–84.
- [2] Choi C, Yoo HS, Oh JM. *Curr Appl Phys* 2008;8:710–2.
- [3] Choi C, Yoo HS, Oh JM. *Curr Appl Phys* 2008;8:710–2.
- [4] Olea, N.; Pulgar, R.; Perez, P.; Olea-Serrano, F.; Rivas, A.; Novillo-Fertrell, A.; Pedraza, V.; Soto, A. M.; Sonnenschein, C. *Environ.Health Perspect.* 1996, 104, 298.
- [5] Y. Ding, H. Alias, D. Wen and R. Williams, *Int. J. Heat Mass Transfer.* 2006, **49**, 240-250.
- [6] G. Paul, J. Philip, B. Raj, P.K. Das and I. Manna, *Int. J. Heat Mass Transfer.* 2011, **54**, 3783-3788.
- [7] Y. Hwang, J.-K. Lee, J.-K. Lee, Y.-M. Jeong, S.-i. Cheong, Y.-C. Ahn, S.H. Kim, *Powder Technology* 186 (2008) 145–153.
- [8] Hwang Y, Park HS, Lee JK, Jung WH. *Curr Appl Phys* 2006;6S1:e67–71.
- [9] Lee JH, Hwang KS, Jang SP, Lee BH, Kim JH, Choi SUS, et al *Int J Heat Mass Transfer* 2008;51(11–12):2651–6.
- [10] X.F. Li, D.S. Zhu, X.J. Wang, N. Wang, J.W. Gao and H. Li, *Thermochim Acta.* 2008, **103**,469-98.
- [11] S.M. Saterlie, H. Sahin, B. Kavlicoglu, Y. Liu and A.O. Graeve, *Chem. Mater.* 2012, **24**, 3299-3306.
- [12] Ceylan A, Jastrzembski K, Shah SI. *Metall Mater Trans A: Phys Metall,Mater Sci* 2006;37A(7):2033–8.
- [13] J.A. Eastman, S.R. Phillpot, S.U.S. Choi and P. Keblinski, *Annu. Rev. Mater. Res.* 2004, **34**, 219-246.

- [14] Shaikh S, Lafdi K, Ponnappan R., *J Appl Phys* 2007;101(6):7.
- [15] Y. Yang, Z.G. Zhang, E.A. Grulke, W.B. Anderson, G. Wu, *Int. J. Heat Mass Transfer* 48 (6) (2005) 1107–1116.
- [16]. Saidura,* , K.Y. Leong^b, H.A. Mohammad^c, A review on applications and challenges of nanofluids
- [17] S.M. Saterlie, H. Sahin, B. Kavlicoglu, Y. Liu and A.O. Graeve, *Chem. Mater.* 2012, **24**, 3299-3306.
- [18] S.M. Saterlie, H. Sahin, B. Kavlicoglu, Y. Liu and A.O. Graeve, *Chem. Mater.* 2012, **24**, 3299-3306.
- [19] D. Li, B. Hong, W. Fang, Y. Guo and R. Lin, *Ind. Eng. Che. Res.* 2010, **49**, 1697-70
- [20] D.H. Yoo, K.S. Hong and H.S. Yang, *Thermochim. Acta.* 2007, **455**, 66-9.
- [21] Y. Hwang, J.-K. Lee, J.-K. Lee, Y.-M. Jeong, S.-i. Cheong, Y.-C. Ahn, *Powder Technology* 186 (2008) 145–153
- [22] M.B. Bryning, D.E. Milkie, J.M. Kikkawa, A.G. Yodh, *Applied Physics Letter* 87 (2005) 161909.
- [23] K. Hagen, *Heat transfer with applications*, Prentice-Hall, New Jersey (USA), 1999.
- [24] J. Philip, P.D. Shima, B. Raj, *Appl. Phys. Lett.* 91(20) (2007) 203103–203108.
- [25] F. Kuspert, *Berichte* 1919, **35**, 2815.

[26] Material Research center, Mark R. DeGuire, Case Western Reserve University, www.case.edu/

[27] E.D. Marquardt, J.P. Le, and Ray Radebaugh, Cryogenic Material Properties Database, 11th International Cryocooler Conference June 20-22, (2000) Keystone, Co.

[28] S.L. Shinde, J.S. Geola, High thermal conductivity materials, Springer (2006)

[29] Boaz Vilozny, Paolo Actis, R. Adam Seger, and Nader Pourmand,3. VOL. 5 ' NO. 4 ' 3191–3197 ' 2011

[30] Boaz Vilozny, Paolo Actis, R. Adam Seger, and Nader Pourmand,3. VOL. 5 ' NO. 4 ' 3191–3197 ' 2011