

Thesis work
On
**“Experimental study and mathematical modeling of an EDM
system”**

Forfulfillment of course syllabi in
MASTER OF ENGINEERING (P&I)

Submitted by:

MohitGarg
Roll.No.801282014

Under the guidance of:

Dr. V.P Agrawal
Visiting Professor,
Department of Mechanical Engineering



**MECHANICAL ENGINEERING DEPARTMENT
THAPAR UNIVERSITY PATIALA-147004, PUNJAB, INDIA
JULY, 2014**

CERTIFICATE

This is to certify that the thesis entitled, 'Experimental study and mathematical modeling of an EDM system', being submitted by MohitGarg (Regd. No. 801282014), in partial fulfillment of the requirements for the award of degree of Master of Engineering in Production Engineering of Mechanical Engineering Department, Thapar University, Patiala, is a record of candidate's own work carried out by him under our supervision. To the best of our knowledge, the content of this thesis does not form a basis for the award of any previous degree to anyone else.

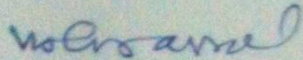

Dr. V.P Agrawal

Visiting Professor

Thapar University, Patiala

(Countersigned by)

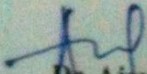

Dr. Ajay Batish
Professor and Head, MED
TU, Patiala



Dr. S.K. Mohapatra
Dean of Academics Affairs,
TU, Patiala

DECLARATION

I hereby declare that the report entitled '**Experimental study and mathematical modeling of an EDM system**' is an authentic record of my study carried out as requirement for the award of degree of ME (Production and Industrial Engineering) at Thapar University, Patiala under the supervision of Dr. V.P Agrawal, Visiting Professor, Thapar University, Patiala during 4th semester, Dec- July 2014.

Date: 15/07/15

Mohit Garg

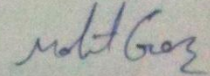

It is certified that the above statement made by the student is correct to best of my knowledge and belief.

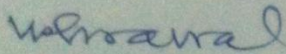

Dr. V.P Agrawal

Visiting Professor

Thapar University, Patiala

ACKNOWLEDGEMENT

I express my deep sense of gratitude and a very sincere thanks to my guide **Dr.V.P Agrawal**, Visiting Professor, Mechanical Engineering department, Thapar University, Patiala for their indefatigable guidance and full support which helped me in the accomplishment of this project. I am highly indebted to them for their painstaking efforts and invaluable suggestions during the period of work.

Mohit Garg

ABSTRACT

Purpose- The purpose of this research study is the analysis of an EDM system completely by considering all its subsystems simultaneously and developing a method to describe the EDM system based on its structure and developing a mathematical model to compare different EDM systems based on their final scores obtained from these mathematical models. In accomplishing this task first of all different subsystems of an EDM system has been identified by literature survey. After finding these subsystems the next step was to find out the interactions between them. These interactions between these subsystems has been shown as graph models. From these graph models a number of matrices has been developed and from these matrices a permanent function has been developed. This permanent function will give us the final mathematical values for a particular EDM system. By obtaining these mathematical values we can compare different EDM systems with each other and an optimum system can be find out. This final system which we have founded would give us the desired results.

Methodology/approach – Elements constituting the EDM system have been identified with the help of literature survey and along with this the interaction between these subsystems have been identified. These all have been shown with the help of a graph model approach. The different variable permanent models and matrix models has been drawn to do the total analysis.

Originality/value – This methodology of graph theory is a mechanism to do system wide optimization of an EDM system. Here through this paper an attempt has been made to do a comprehensive and integrated analysis of the EDM system.

Keywords – EDM system, Performance matrix, Modelling, System analysis, Graph theory.

TABLE OF CONTENT

Declaration.....	i
Acknowledgement.....	ii
Abstract.....	iii
Chapter 1: Introduction.....	1
1.1 Production process.....	1
1.2 Machining process.....	1
1.3 Electrical Discharge Machining.....	2
1.4 Process parameters.....	5
1.4.1 Discharge Voltage.....	5
1.4.2 Peak Current.....	6
1.4.3 Pulse Configuration.....	6
1.4.4 Polarity.....	6
1.4.5 Electrode Gap.....	7
1.4.6 Type of Dielectric flushing.....	7
1.5 Modifications in EDM.....	8
1.5.1 Powder Mixed EDM.....	8
1.5.2 Magnetic Force Assisted EDM.....	9
1.5.3 Ultrasonic EDM.....	10
Chapter 2: Literature Review.....	11
2.1 Powder mixed EDM.....	11
2.2 Literature summary& Gaps.....	28
Chapter 3: Methodology.....	29
3.1 Aim of the study.....	29
3.2 Methodology.....	29
3.2.1 Description of machine / set up.....	30
3.2.2 Factors.....	30
3.2.3 Experiment design.....	3
3.2.5 Graph theory.....	31
3.3 Work completed	33
3.3.1. Already purchased material.....	33
3.3.2 Enquired/ Ordered material.....	33

3.3.3 Trial experiments conducted.....	34
3.3.3 Experimental details.....	35
3.3.4 Observation Table/Graphs.....	35
3.4 Conclusions.....	38
Chapter 4: Results	39
4.1 Graph theory approach.....	39
4.1.1 Subsystems of an EDM.....	39
4.1.2 Interactions of subsystems.....	41
4.1.3 Graph theory implementation on EDM.....	48
4.2 usefulness of methodology.....	56
Conclusions.....	57
Chapter 5: References.....	58-60

LIST OF FIGURES

Fig. 1.1: Production process.....	1
Fig. 1.2: Spark initiation in EDM.....	3
Fig. 1.3: EDM Set-up.....	3
Fig. 1.4: The Lazarenko RC circuit.....	4
Fig. 1.5: Variation of capacitor voltage with time in RC circuit.....	4
Fig. 1.6: Pulse waveform of controlled pulse generator.....	5
Fig. 1.7: Actual profile of a single EDM pulse.....	6
Fig. 1.8: Principle of powder mixed EDM.....	8
Fig. 1.9: Magnetic force and effect on debris removal.....	9
Fig. 1.10: Ultrasonic vibrating tool EDM.....	10
Fig. 2.1: Effect of dielectrics on MRR and TWR.....	12
Fig. 2.2: Effect of area on SR.....	13
Fig. 2.3: Effect of current on SR and efficiency.....	14
Fig. 2.4: MRR relation with different polarities.....	15
Fig. 2.5: TWR relation with different polarities.....	15
Fig. 2.6: SR comparison with water and Si added water.....	15
Fig. 2.7: Comparison of current, MRR.....	16
Fig. 2.8: Comparison of pulse on time, MRR.....	17
Fig. 2.9: Main effect plot for MRR.....	18
Fig. 2.10: Main effect plot for EWR.....	19
Fig. 2.11: Micro hardness comparison.....	21
Fig. 2.12: Effect of powder concentration on MRR.....	23
Fig. 3.1: EDM machine.....	30
Fig. 3.2: Machined work piece.....	34
Fig. 3.4: Material Removal Plots.....	36
Fig. 3.5: Tool Wear Plots.....	37
Fig. 3.6 Surface roughness plots.....	37
Fig. 4.1 EDM system tree diagram.....	40
Fig. 4.2 Plot for MRR.....	42
Fig. 4.3 Plot for TWR.....	43
Fig. 4.4 Plot for SR.....	44
Fig. 4.5 Plot for MRR.....	45

Fig. 4.6 Plot for TWR.....	47
Fig. 4.7 Plot for SR.....	48
Fig. 4.8 Graphical presentation of EDM system.....	49
Fig. 4.9 Structural analysis of EDM system.....	54

LIST OF TABLES

Table 3.1: Details of purchased metal powders.....	33
Table 3.2: Details of tool material.....	33
Table 3.3: Details of work materials.....	33
Table 3.4: Observation table (Trial Experiments).....	35
Table 3.5:Observation table (Final Experiments).....	41-47

CHAPTER 1

INTRODUCTION

1.1) PRODUCTION PROCESS

A production process is that through which a raw material is converted into a useful final product. It mainly involves three steps.

- 1) Raw material extraction
- 2) Transformation process
- 3) Final product

Raw material extraction: It is the very first process of a production process. After raw materials extraction it goes through transformation process and here with the applications of Man, Machine, Mode etc. it get converted into final desired output.

Transformation process: This is the second stage in production of any product. Here at this stage with the help of different machining operations, final shape is given to work piece. These operations are known as primary and secondary operations.

- Primary operations: with the application of these processes, initial shape is given to extracted raw material. These involve forming, forging and casting etc.
- Secondary operations: after performing the primary operations, the final shape is given to the product and dimensional accuracy is achieved as mentioned in final design, with the help of these secondary operations.

1.2) MACHINING PROCESSES:

With help of these processes, material is removed from initially formed rough shape product. Final product dimensions and finish are achieved by their applications. In today's world a number of machining processes are performed, depending upon the requirement of product.

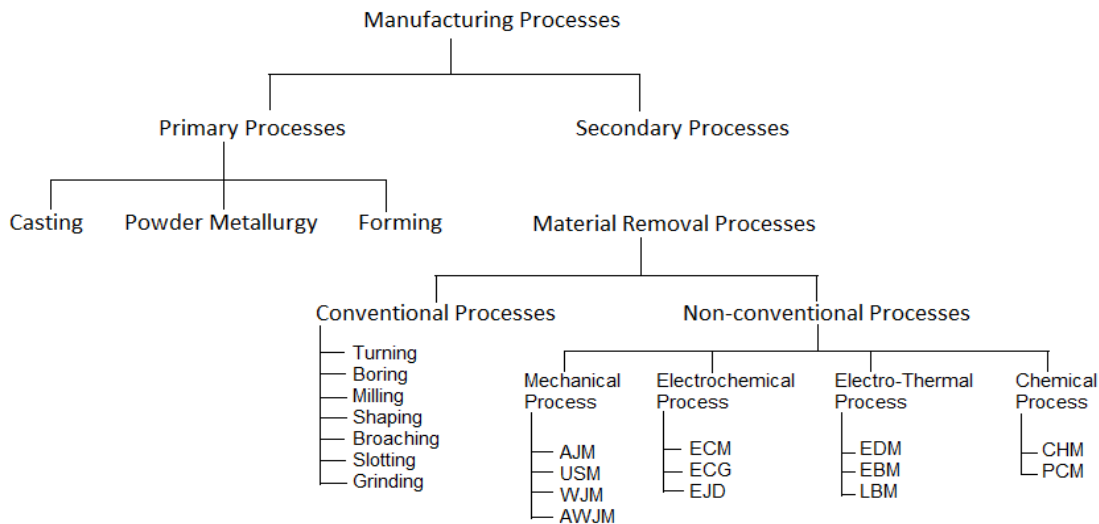

Fig.1- Classification of manufacturing processes

- **Conventional machining:** these are the processes where a contact between tool and work piece is must to remove material from work surface. Depending on the properties of work material, the removed material may or may not be detached in the form of chips. The one major drawback of these machining operations is their inability to machine harder materials. Because to machine hard materials the tool material must be harder than that of work piece material. Boring, turning, milling, shaping etc. are the examples of these machining operations.
- **Non-conventional machining:** To solve the problem of machining of hard materials new techniques were developed, which are known as non-conventional machining processes. In these processes no work piece and tool contact is required to remove material from work surface. Instead of mechanical energy, different forms of energy are used, depending upon the requirement of product. Depending upon the form of energy used in machining, these machining processes are divided into different types as mentioned in above diagram.

1.3) ELECTRIC DISCAHRGE MACHINING:

This is one from the non-conventional machining group. EDM is used for machining hard and difficult to cut materials. One of the basic requirement for a material to be cut with the help of EDM technique is that, it should be conductive. EDM method can be used for a number of metals and their alloys. EDM is a non-conventional' machining method, because it uses electric discharge energy to remove the material. It is similar to another non-

conventional machining processes like ECM, WJM, AJM, LBM etc. in the way of machining energy type. These all processes are different from conventional machining processes like milling, casting, drilling, turning etc. because of the difference of energy being used in these processes. Ideally, EDM involve the breakdown and restoration of dielectric medium present in between work piece and tool. The efficiency of an EDM process depends upon a number of factors, like type of dielectric medium used, power source etc. The electric properties of this dielectric medium vary from place to place depending upon the concentration of debris present in it. The presence of these debris affect the efficiency of EDM (<http://en.wikipedia.org>). The conversion of electrical energy into thermal energy through a series of discrete electrical discharges occurring between work piece and tool are widely accepted principle of material removal in EDM(Tsai and Wang 2001). The generation of intense heat due to these electric discharges between work piece and tool causes the melting and evaporation of work material in that zone (Fig 1.4). The electrode attached to the positive terminal erodes at a faster rate as compare to the electrode with negative polarity. Due to this reason the work piece is attached to positive terminal usually. The material removal mechanism is shown in (Fig. 1.2).

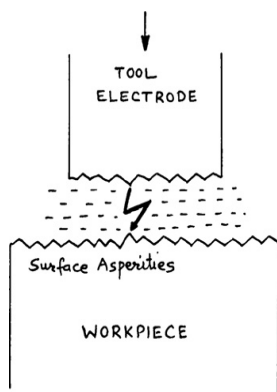

Fig. 1.2: Spark initiation in EDM (Kumar S. et al. 2009)

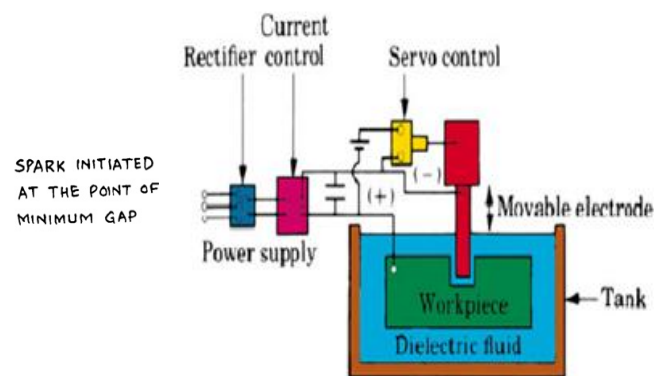

Fig. 1.3: EDM Set-up (<http://www.themetallurgist.co.uk>)

The discharge would take place at the place where the gap is minimum. Means the point of discharge every time would be different. By this way the erosion of metal will proceed. After each discharge, the charging of capacitor is done with the help of a DC source through a resistor as shown in (Fig. 1.4), and the next spark is transferred to the next location.

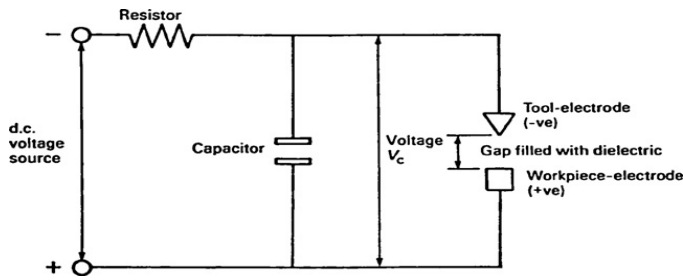

Fig. 1.4: The Lazarenko RC circuit (McGeough 1988)

A particular sequence is followed during charging and discharging of the capacitors (Fig. 1.5), this will decide the machining time for process.

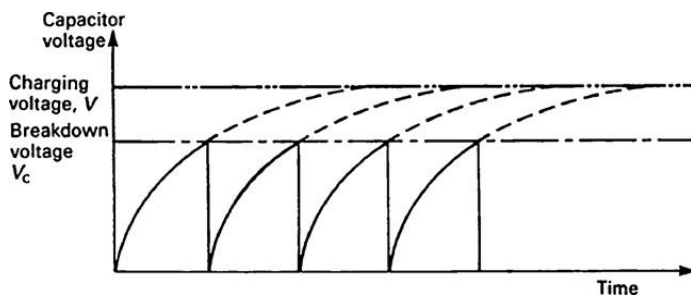

Fig. 1.5: Variation of capacitor voltage with time in RC circuit (McGeough 1988)

The whole machining of the work piece will be completed by these discharges. Their total effect will cause a large amount of work material erosion. The shape of the machined surface will be exactly same as that of tool. The MRR and TWR are measured in mm^3/sec . The main function of dielectric is to serve as a concentrating medium to concentrate the discharge energy into a narrow cross-sectional area. Another function of dielectric medium is to serve as a coolant for both electrodes, and it also helps in flushing of debris from discharge gap. In EDM a servo motor is used for the movement of tool towards work piece. The movement of tool towards work piece is required in EDM because, due to continue erosion of work material, there would be an increase in spark gap. This will create hindrance in spark initiation and ultimately sparking will cease to occur. So to maintain a proper gap between both electrodes, servo motor is used.

A controlled pulsed generator is used to eliminate the problem higher temperature generation, which caused higher TWR. A waveform generated with this generator is shown in Fig. 1.6.

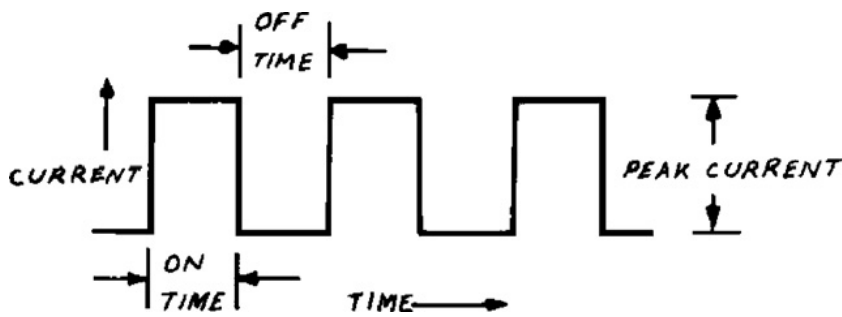

Fig. 1.6: Pulse waveform of controlled pulse generator (McGeough 1988)

1.4 PROCESS PARAMETERS

1.4.1 Discharge voltage

There are two parameters, one is dielectric medium strength and another is spark gap, which controls the discharge voltage (Kansal et al. 2005b). At initial stage when no current is flowing through the discharge gap, the discharge voltage is very high until it creates an ionized path for smooth flow of current carriers. Once this ionization takes place and current starts flowing then the voltage will drop automatically to a level to stabilize the working gap. The spark gap is determined by voltage. On increasing the value of voltage, the discharge gap will increase and this will help in easy removal of debris from working gap, which will cause a good surface finish. The increase in electric field strength due to an increase in voltage cause higher MRR and SR. Actual profile of single EDM pulse is shown (Fig. 1.7).

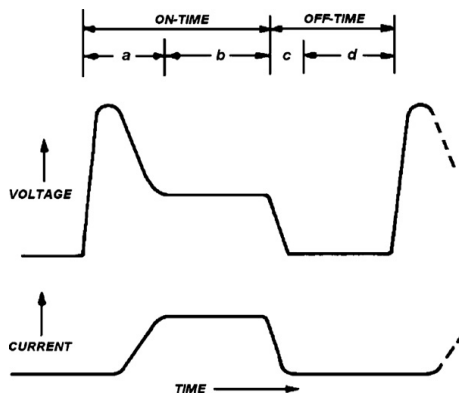

Fig. 1.7: Actual profile of a single EDM

1.4.2 Peak Current

During every pulse, the current reaches to maximum level, which is known as peak current. In all EDM processed, the amount of maximum current is governed by machined area. Higher current causes higher MRR due to an increase in discharge energy of pulses. This will also affect the surface finish of work piece negatively and causes poor surface finish.

1.4.3 Pulse configuration

In EDM two pulse times, pulse on time and pulse off time are very important because of their direct effect on process efficiency (**Kansal et al. 2005a**). To remove material from work surface high electric discharge energy is required. The current value and pulse on time control this energy. Pulse off-time is known as pulse interval and Pulse on-time as pulse duration. In comparison to a shorter pulse duration, a longer pulse duration will produce higher MRR and deeper craters. But if pulse on time is exceeded from its normal range than it will cause a lower MRR. Also to prevent continued sparking at one point the pulse interval should be greater than the time of deionization of dielectric (**Fuller 1996**).

1.4.4 Polarity

Polarity consideration is very important in EDM. Both types of polarity, positive polarity and negative polarity can be used in EDM depending upon the output required. In case of positive polarity, work piece would be attached to positive pole and tool to negative pole. While machining both electrodes gets eroded, but at different levels. When using small pulse on time duration, work piece is preferred to be attached with positive pole (anode), because of the high acceleration of electrons as compare to positive ions. Due to this the heat generation by electrons will be higher than the heat generation by positive ions. This higher heat generation will cause high MRR. But when large pulse on time is used than work piece is attached to cathode. Because the energy generated for large duration is higher in case of positive ions as compare to electrons. So higher MRR will be achieved with this arrangement (**Zhao 2011**).

1.4.5 Electrode gap

A minimum gap between two electrodes is desirable for the process to proceed. This gap is maintained by using a servo motor to control the movement of tool. Gap between electrodes affects the process to a great extent. In normal gap setting, the machined debris will start accumulating in between the gap. Due to this, machining will not be proper. But when gap is increased, there will be more space for debris to remove. So machining will be smoother and good surface finish will be achieved.

1.4.6 Type of Dielectric flushing

The dielectric plays an important role in EDM. The properties which are desirable for a good dielectric are, high dielectric strength, flushing ability, effective recovery after break down etc. (Wong et al. 1995). The efficiency of EDM process mainly depends upon dielectric medium being used. It also serves as a cooling agent for both electrodes.

1.5 MODIFICATIONS IN EDM

Non-traditional methods are mainly used only when the conventional processes can't work satisfactorily, although their material removal rate is comparatively very low than conventional ones. Hence for improvement in MRR and for achieving better surface finish, different techniques are being implemented on conventional EDM process. Some such techniques are:

- i) Powder mixed EDM
- ii) Magnetic assisted EDM
- iii) Dry or near dry EDM
- iv) EDM using ultrasonic vibrations

1.5.1 Powder mixed EDM:

Powder mixed EDM is an advanced method of machining. In this method the capabilities of EDM process has been improved. The MRR and surface finish of PMEDM is higher as compare to general EDM. The main reason for this change is the reduced dielectric strength of dielectric medium due to the addition of conducting particles. Due to this the working gap increase, which results an improved surface finish after machining. The invention of this technique was to achieve high surface finish on already machined surfaces. The machined surface becomes more corrosive resistant. The reason for decreasing the insulating strength of dielectric medium is the

bridging effect of charged particles. These charged particles on application of current interlock with each other in the direction of application of current (Fig. 1.8).due to this, early short circuiting take place, which results in early explosion. Due to the presence of conducting particles series discharges would take place, which results in high heat energy generation at work surface. This will result in higher MRR. Also due to these added particles the gap between electrodes gets wider. This will results in an easy removal of debris from gap and also at the same time shallow craters will be formed due to large gap (Zhao 2002). This will give an improved surface finish.

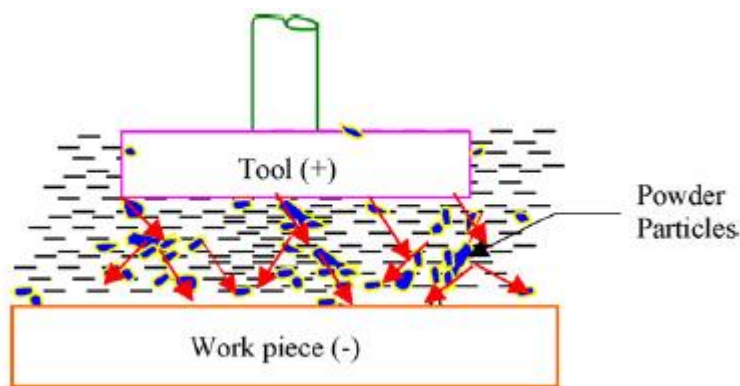

Fig. 1.8: Principle of powder mixed EDM (Kansal et al. 2007)

1.5.2 Magnetic force assisted EDM:

EDM is well known for its ability to cut hard to cut materials and also to cut intricate shapes which are otherwise tough to cut. The surface roughness and MRR depends upon many factors. The presence of small or big craters will affect the surface quality of the machined surface. The main problem in EDM is the accumulation of debris in work gap. These debris results in interruption of machining and also bad surface finish. To improve the process efficiency, these debris must be removed from the gap. Kim et al. (1997) investigated the effect of application of magnetic field on the electrolytic finishing process. It was found that by applying magnetic field the linear path of ions gets converted into cycloid motion. Due to this the surface finish got improved. The expulsion of debris from working gap resulted in this improvement in surface quality. The arrangement for MEDM is shown in Fig. 1.9.

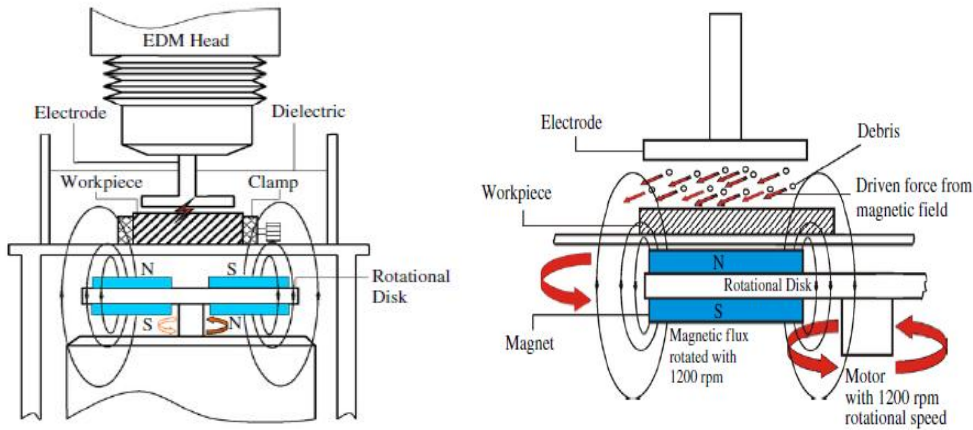

Fig. 1.9: Magnetic force set-up and its effect on debris removal
(Lin and Lee 2008)

1.5.3 EDM using Ultrasonic vibrations:

Ultrasonically vibrated tool as shown in fig. 1.10 is used in EDM to improve MRR and surface finish. The high vibrations of tool got transferred to slurry. This enhance their ability to detach more material in smaller time. This will reduce the machining time. Also the discharge efficiency got improved due great pressure variations between the discharge gap. This helps in expulsion of more molten metal. This also improves its ability to work with a narrow discharge gap. The thermal stresses got reduced and also affected layer got reduced. Micro cracks are observed to be small in size. Surface roughness, hardness and relative wear are also affected. (<http://link.springer.com>).

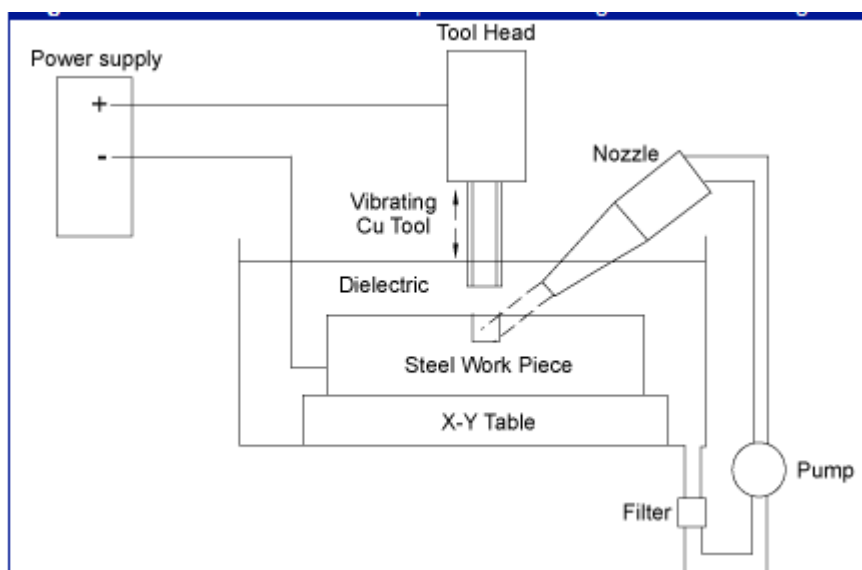

Fig 1.10- EDM using ultrasonic vibrated tool

CHAPTER- 2

1 LITERATURE REVIEW

In this report literature review of modified EDM process has been discussed. This modified EDM process is known as Powder Mixed Electric Discharge Machining (PMEDM).

➤ POWDER MIXED EDM :

Yan et al. (2004) mixed the Urea into distilled water to study the effect on pure titanium metals using EDM machining process with a change in machining characteristics. Also the effect on surface properties were also checked with urea addition in pure water. In these experiments, the machining parameters like peak current, dielectric type, and duration of pulse were changed to find out their effects on machining performance. These machining performances include material removal rate (MRR), electrode wear rate (EWR), micro hardness and surface roughness. The evaluation of effects of reinforced surface were done with the help of wear resistance and Micro hardness tests. After performing experiments on EDM it was found that the surface wear resistance of machined surface has improved to some extent. This mainly happened due to the transfer of nitrogen present in urea to titanium metal surface, which results in the formation of TiN layer. The main problem in earlier times was the defects on surface of a machined part like, pores, micro cracks, burns etc. These all are the result of high temperature gradient while machining. These defects affect the service life of machined part and also results in poor surface precision. This creates the need for post machining operations for the improvement of surface properties. Such subsequent treatment consume great amount of time and also increase the fabrication cost and time. To solve this problem many researchers have applied different methods to investigate modifying machined surfaces by EDM. They added different powders like chromium, nickel and silicon into dielectric solution to study their effects on the surface properties of work piece. They found that the addition of these powders greatly improve the surface properties like, hardness, wear resistance and corrosion resistance etc. In this work, also an attempt has been made to improve the surface properties of pure titanium by using urea in to distilled water to improve its wear resistance. The transfer of nitrogen from urea to work surface on applying electric discharge was as expected.

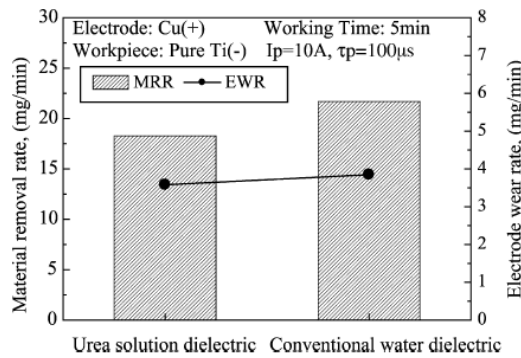

Fig. 1. The influence of different type dielectric on material removal rate and electrode wear rate.

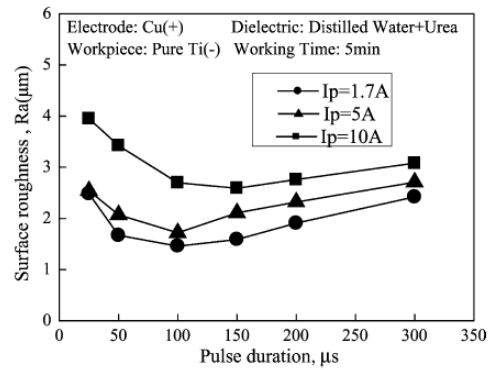

Fig. 5. Effect of peak current on surface roughness.

It was found that with an increase in current value the surface finish deteriorates. This mainly happened due to an increase in the discharge energy and impulsive force. Due to this high value of discharge energy and impulsive force, more molten metal get removed resulting in larger and deeper craters. This results in a coarser surface finish.

Pecas et al. compared the results of powder mixed EDM and conventional EDM for generation of high quality surfaces. To do this two parameters were set, one was the electrode area and another was crater morphology. An analysis of these two parameters were conducted to find out the surface roughness in both PMEDM and conventional EDM. It was found that while working on PMEDM the electrode area and the surface quality exhibit a linear relationship. Normally with increase in the surface area of an electrode results in the occurrence of superficial heterogeneities which results in deterioration of surface quality of work piece. To get a good surface finish as in case of surface polishing, low discharge energy is required. This low discharge energy requirement compels the user to use small electrode to work gap. The eroded particles starts accumulating while using small working gap. With the increase in electrode area the eroded particles tend to accumulate in the gap zone. This leads to short-circuiting between work piece and electrode. These abnormal discharges results in surface damages and an increase in processing time. To solve this problem powder mixed EDM (PMEDM) technique must be used. In this PMEDM conductive and semi conductive powder particles are present in EDM dielectric in suspended form. This results in the reduction of dielectric strength which leads to larger working gap. With a larger working gap it becomes easier to remove the eroded particles which leads to reduction in probability of abnormal discharges.

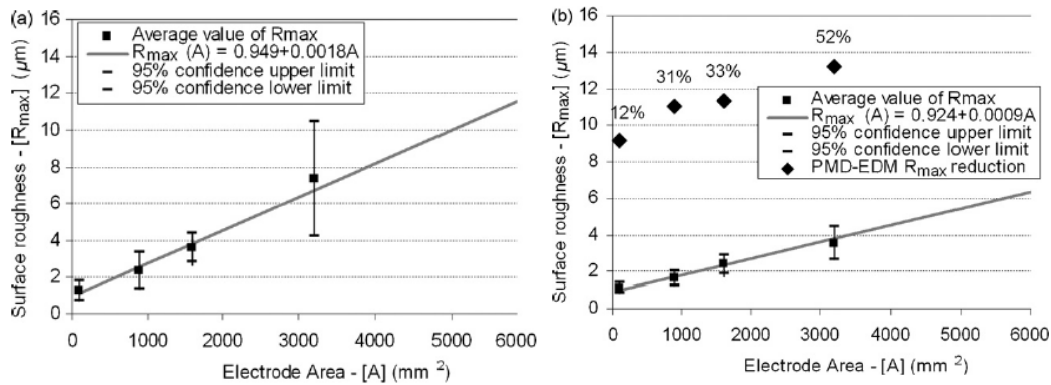

Fig. 2.2 – Distribution of the surface roughness with the electrode area for (a) EDM conventional conditions and (b) PMD-EDM conditions

Due to this reduced probability of abnormal discharges along with a larger surface area of electrode the surface finish of work piece can be improved very easily. Surface heterogeneity also get reduced while using PMEDM which results in an increase in process robustness. So it can be concluded that it is much convenient to use PMEDM when large electrode areas and high surface finish is required.

Wang et al. (2002) studied the efficiency of machining and surface roughness while using PMEDM in rough machining operations. A number of studies are present which shows that with the help of PMEDM surface quality and surface roughness can be improved in finishing phase of machining. But before this work no one has worked to find out the machining efficiency of PMEDM process while rough machining work. It has been found that while using PMEDM the working gap will get increased and this increased working gap will improve the efficiency of the process and also the surface finish of work piece. With an increase in peak current the discharge energy would get increased which will enhance process's machining efficiency but at another hand this increased energy would affect the surface roughness negatively. But if the pulse width is increased than this will result in a slight change in the work efficiency but it will create a bad surface roughness. So to get good results a smaller pulse width and high peak current should be used.

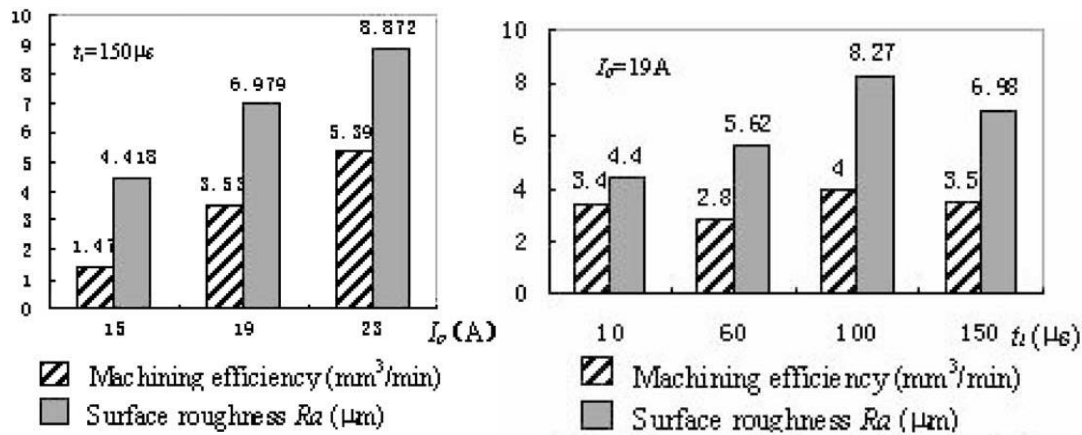

Fig.2.3- Influence of peak current and pulse width on machining efficiency and surface roughness respectively.

Yang et al. (2008) added SiC powder in pure water to use this mixture as dielectric medium in an EDM process. As SiC is a conductive material, its addition will help to decrease the dielectric strength of medium. This will help to increase the working gap, which will again help in easily removal of debris. This all will increase the MRR of process. Most of the time kerosene is used as EDM dielectric fluid. There are some problems a person will face while using kerosene as an EDM dielectric medium, like air pollution, high discharge temperature which causes it to decompose and liberation of carbon elements and these carbon elements will adhere to the electrode surface which will create hindrance in extrusion of debris. Thermal conductivity of kerosene is poor and this poor thermal conductivity will affect MRR. Due to this poor property the MRR will decrease. But Pure water has a high flowing rate, a high thermal conductivity, a low viscosity coefficient. Also temperature of pure water will not be changed very much while working for long hours so MRR will be sustained to initial value or we can say will not be affected negatively. Also depending on the workpiece and electrode tool connection the Power sources can be divided into positive polarity and negative polarity. The discharge current comprised ion and electron currents, the electron current constituted the main part of the total current when the pulse duration was short. When the pulse duration was long it was the ion current which constituted the large part of the total current. So to get higher MRR values the workpiece was set on positive as well as negative polarities depending upon pulse on time. Results were also collected for electrode wear rate when pure water was used for EDM machining. Fig. 4 reveals that while using NP in machining process electrode wear decreased with an increase in pulse duration. However, in case of PP in machining the electrode wear increased with increase in pulse duration. To get a lower electrode wear rate these two arrangements discussed above must be implemented.

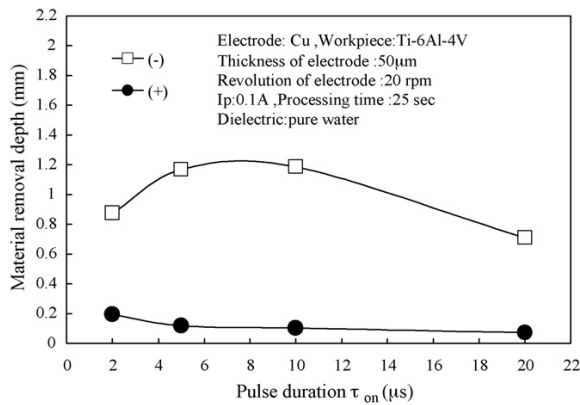

Fig.2.4- Relationship of MRR in different polarities

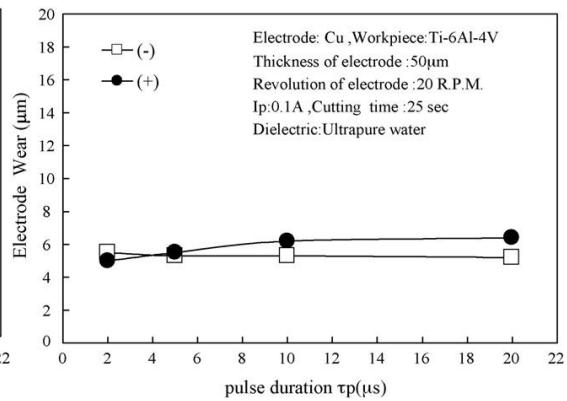

Fig.2.5- Relationship of TWR in different polarities

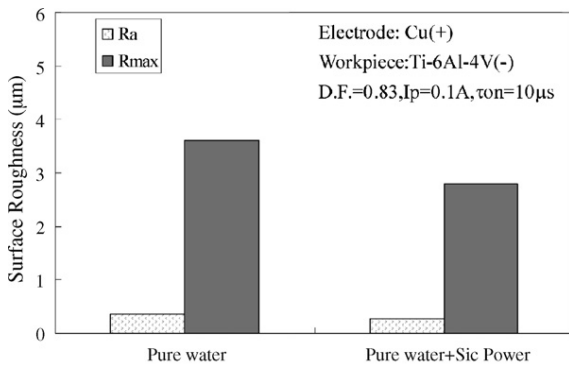

Fig.2.6- comparison of surface roughness using pure water alone and pure water added Si powder

Rahuman et al. (1997) studied that what effect a mixture of fine powders into dielectric medium would produce on surface finish of workpiece. A number of different combinations of powder-mixed dielectric and workpiece have been found to produce mirror-finish. These mirror finished surfaces was found to be produced by using an appropriate setting of parameters like electrode polarity, pulse duration and a right combination of workpiece material and powder characteristics. Experimentally generated results shows that a very high surface quality with high machining rate can be achieved by using different powders like aluminium, silicon, graphite etc. experimental results shows that, that an increase in powder concentration would affect the machining rate. But a very high concentration also affects the machining rate in an adverse way, because of the frequent shorting of electrodes. It has been found that a number of factors like dielectric fluid, flushing conditions, pulse current, servo settings etc. affects the spark gap distance. Due to the presence of these powders the spark

gap increases, which can be attributed to the presence of debris in spark gap. Also an increase in powder concentration tends to increase the spark gap distance.

Kansal et al. (2007) used silicon powder into kerosene oil to study the effect of this combination on D2 steel's machining. They mainly worked on six parameters to measure the process performance. These six parameters were, pulse on time, pulse off time, peak current, powder concentration, grain size and nozzle flushing. Machining rate was selected as a parameter to judge the process performance. After analyzing the results it was found that except nozzle flushing all five parameters affects the machining rate significantly. But analysis of results also shows that two process parameters, peak current and powder concentration affects the process most.

$$MR(\text{mm}^3 / \text{min.}) = \frac{\text{Workpiece weight loss (gm)}}{\text{Density (gm / mm}^3) \times \text{Machining time (min.)}}$$

The reason for an increase in machining rate with an increase in current value is spark energy. When current was increased the current carriers, electron and ions were accelerated towards their respective electrodes with high speeds. This concentration of current carriers was further increased by powder particles. When these current carriers' strikes with powder particles than these particles further strikes with other carriers and generate more carriers. This results in an avalanche of current carriers. This avalanche of carriers results in increased discharges per unit time on work piece surface. This results in an increase in spark energy which resulted more erosion on work surface. The faster sparking started within a discharge, which results in the faster erosion from the workpiece surface, and hence higher MR.

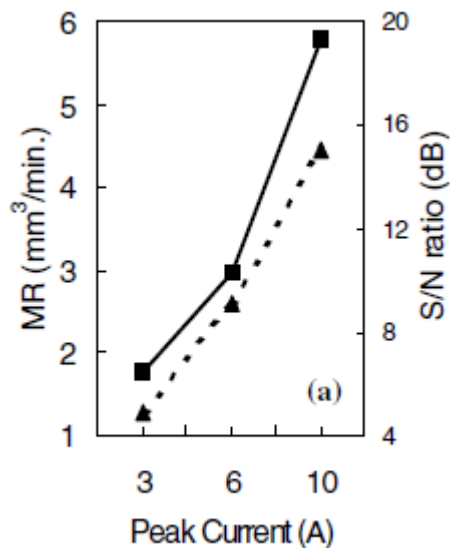

Fig -2.7

One another factor which affects the process results was pulse on time. It was found that with an increase in pulse on time, the machining rate first increased than after increasing to a particular level it starts decreasing. The main reasons for this variation were, the vaporization of work surface and short circuiting. At short pulse duration lesser surface vaporization was the main reason for lower MR and on another side at longer pulse duration a frequent short circuiting due to presence of debris caused a lower MR.

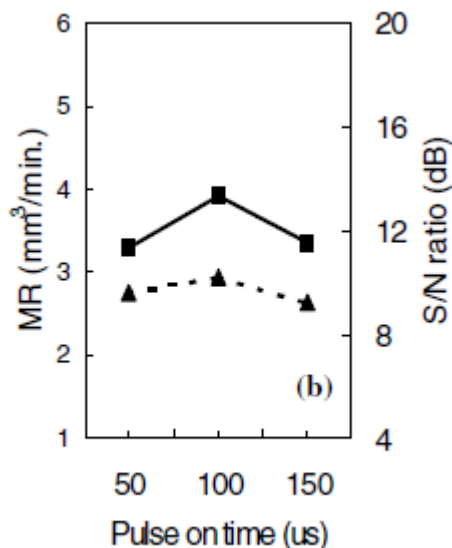

Fig -2.8

Luis et al. (2005) used reaction bonded SiC ceramic as work material. The reason for the selection of this material was it's wide range of applications in industrial field like, bearings,

seals, linings, gas turbines etc. Five design factors, duty cycle, current intensity, OCV, pulse time and flushing pressure were considered to study their effect on MRR and TWR. While conducting experiments it was found that the most influential factors out of these five are current intensity and open circuit voltage. But another three factors also affected these outputs but not too much variation. These two factors affect the MRR in a positive way, means on increasing the value of these two factors the MRR also increased. The reason for this behavior is the increase in discharge energy when input current was increased. On the other hand with an increase in the open circuit voltage the work gap and discharge energy both increased which finally leads to an increase in MRR. Now in case of duty cycle, though its effect on MRR is lesser but it shows a different behavior with changing its values. With an increase in duty cycle first the MRR value starts increasing and after reaching to a particular level this value starts decreasing. This behavior is because of the presence of debris in dielectric medium. Also the value of this time period can't be lowered from a certain value, because a minimum value of time is required between two sparks for flushing of debris from gap zone.

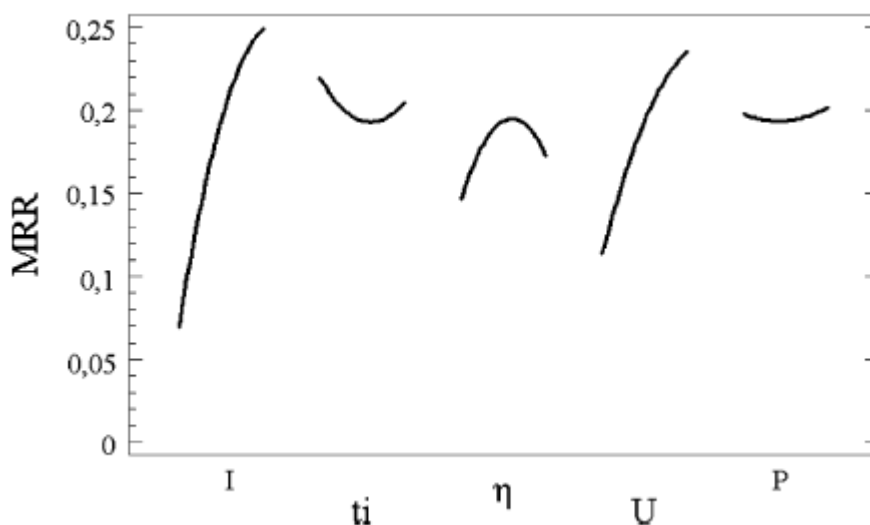

Fig .2.9. Main effects plot for MRR

Also the effect of these factors on EWR was studied. From the results it was determined that the most influential factor among all these was current intensity. With an increase in the current intensity the EWR decreased. This behavior remains for a specific value of current, after which it starts increasing. This change in the behavior after a certain value was due to the high value of current density. Due to this high current density the electrode wear

increased and it reversed the results which were obtained at lower current densities. The second factor which is pulse on time didn't affected the EWR too much. Results shows that with an increase in pulse on time, the EWR decreased. The third factor which is flushing pressure also affected the EWR significantly. A moderate flushing pressure resulted in lower EWR, because of the adequate flushing of debris. But when it was increased than it resulted in higher EWR. This was because of the turbulence created in dielectric fluid due to this high pressurized flush. With respect to the third significant factor for EW, i.e., flushing pressure, an increase in the latter tends to improve the wear on the electrode, at least for the work interval studied.

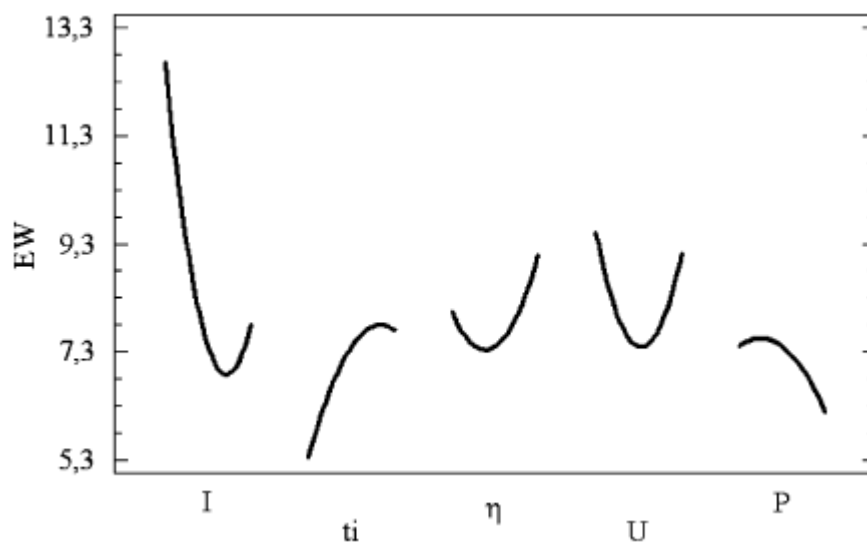

Fig.2.10. Main effect plot for EWR

Kumar et al. (2012) studied the effect of tungsten powder mixed dielectric fluid on surface hardness of die steels while working on EDM. There was two different ways to transfer tungsten to the work material, either by tool erosion or by using powder mixed dielectric. Also the liberation of carbon atoms from dielectric cause surface modification. In this work three different die steels were used to note their responses for surface modification. Pulse off time, Peak current and pulse on-time were choose as variable factors and the response parameter were selected as micro-hardness of surface machined. Final results shows a 100% improvement in micro hardness value for all three die steels when X-ray diffraction (XRD) and spectrometric analysis were used. This improvement in hardness value is linked with the transfer of tungsten carbide to machined surface. Tungsten carbide can only be formed in plasma channel only. The selection of tungsten was made because of its importance as alloying element in die steels for industrial purposes like, tool industries etc. surface alloying

was detected by analyzing increased micro-hardness which were taken as an indicator of alloying. It was also observed that the amount of tungsten deposition was same for all three die steels. The WC which formed in plasma channel was settled down on surface of die steels during pulse off time. Analysis also showed that for getting the same value of surface hardness, the input parameters needs not to be changed.

Table-1

Optimum process parameters and their relative contribution for the best value of micro-hardness.

Parameters	Work material		
	OHNS	D2	H13
Optimum setting	A ₂ B ₂ C ₃	A ₂ B ₂ C ₃	A ₂ B ₂ C ₃
Peak current contribution	71.9%	73.6%	74.6%
Pulse on-time contribution	10.1%	9.2%	8.1%
Pulse off-time contribution	17.7%	16.9%	17.0%

Factor A represents peak current and level A₁ = 2 A, A₂ = 4 A, A₃ = 6 A.

Factor B represents pulse on-time and level B₁ = 5 μs, B₂ = 10 μs, B₃ = 20 μs.

Factor C represents pulse off-time and level C₁ = 38 μs, C₂ = 57 μs, C₃ = 85 μs.

It was observed that out of all these factors peak current and pulse off time affected the results most significantly. Due to high peak current the MRR was high which created machined surface for the deposition of WC. On the other hand more pulse off time was required for the surface of steel to absorb more WC, which resulted in high value of micro hardness.

Hu et al. (2013) compared EDM and PMEDM processes by studying their effect on surface properties of SiC particles reinforced Al matrix composites (SiCp/Al). This is one of the mostly used composite material in industry like, plain bodies, turbine blades, support components of satellites etc. but the main disadvantage of this material in industrial use is its poor machining properties. These poor machining properties are due to the presence of brittle and hard SiC particles. But in case if EDM and PMEDM this is not a problem, because in these machining processes there is no tool to work piece contact as a case in conventional machining processes. But in case of PMEDM due to the presence of large number of Al atoms which helped to decrease the insulation strength of the medium which resulted in easy breakage of working fluid and also helped in enlarging the discharge channel. By applying the same value of pulse width and current, the effective discharge time for PMEDM increased. Due to this longer discharge period more number of SiC particles decomposed, which resulted in higher number of Si and C atoms attached on surface of workpiece. Due to

the above reason the surface micro hardness in case of PMEDM was much higher as compared to EDM.

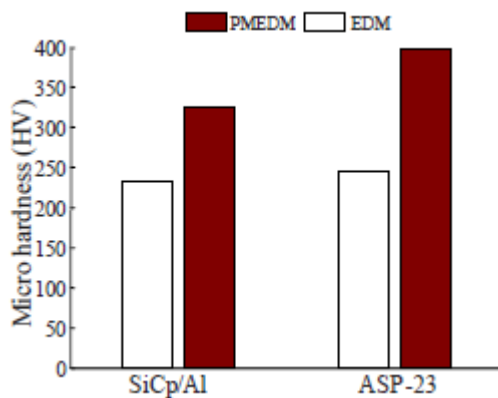

Fig.2.11. Micro hardness comparison

Surface corrosion resistant testing was also done in both cases. It was found that the corrosion resistivity of surface machined by EDM was lesser as compared to the surface machined by PMEDM. The reason for this behavior was found to be the surface cracks and surface texture. In case of EDM it was found that these surface cracks were very much deeper and uneven, due to this when a solution was poured on the surface a large area was present for this solution to react with the surface. Due to this reason more corrosion was reported on surface machined by EDM. But when the same procedure was applied on surface machined by PMEDM than it was found that the number of cracks were less and they were lesser deep as compared to the cracks produced in case of EDM. This mainly happened due to the larger working gap and also lesser discharge energy which leads to a smoother surface after machining. Due to this reason the area for reaction when solution was poured on the surface was lesser, which resulted in lesser corrosion of surface.

Ming et al. (1995) worked on PMEDM to study the effect of powders mixed in dielectric medium on TWR, SR, MRR etc. Their effects on MRR was found positive. It has been found that every powder increased the MRR. Surface finish and MRR were found interlinked as when MRR increased there was deterioration in surface quality. The effect of adding two different powders at the same time in dielectric medium were also studied and the results showed an increase in the MRR value up to a particular range of additives. The main reason for this was increased number of striking particles. By increasing the amount of powder, the surface finish of the machined surface was found to be improved. But this behavior was applicable up to a particular level of addition. Beyond that point when the amount of powder

was increased than the surface quality started deteriorating. The reason for this was found to be the increased number of discharges per unit time and also accumulation of debris between working gap. TWR and MRR were noted together. It was found that with addition of small amount of powder the MRR value doesn't improved much but at the same conditions the TWR was very high. The reason for this high TWR was found to be, the absorption of carbon atoms on surface of tool. But when the amount of powder was increased than it resulted in higher MRR with a slighter change in TWR. The microstructure of the machined surface was found to be different from the rest surface. The main reason for this was determined as melting and solidification of surface layer in machined area. Due to this reason the stresses were found to be present in machined area and due to these stresses cracks were appearing on the surface. But when PMEDM was performed than these problems were found to be solved to a great extent. The reason for this improvement was found to be an increase in working gap, which leads to even current, lower breakdown voltage and lower thermal stresses. The hardness value of surface machined by PMEDM was found to be higher as compare to EDM machined surface. The reason for this was found to be the presence of martensitic layer on surface in case of PMEDM.

Parihandana et al. (2009) used the ultrasonic vibrated dielectric fluid instead of using ultrasonic vibrated tool while machining on PMEDM. The main reason for their implementation of this technique was the accumulation of powder particles and machined debris in working gap, which caused frequent short circuiting between tool and work piece. Due to this the machining time was increased. To eliminate this problem they used this technique. They supplied ultrasonically vibrated powder mixed dielectric fluid because it supplied the powder mixture evenly every where, it eliminated the problem of accumulation of powder particles at the bottom of tank and also helped in increasing the kinetic energy of machined debris. This resulted in easy removal of debris from the work gap, which resulted in lesser short circuiting. The reason for applying ultrasonic vibrations to fluid instead of applying it to tool was its lesser cost and easy implementation. In this process the MRR value was found to be increased significantly. The increased amount of powder also gave the same results of higher MRR value.

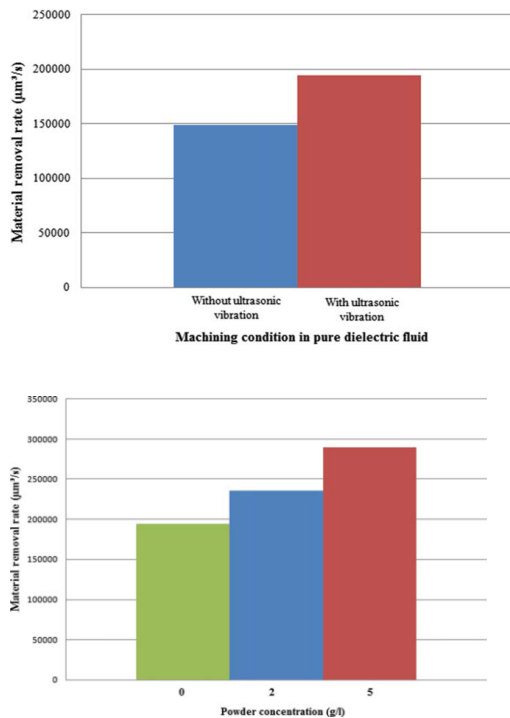

Fig 2.12: Effect of powder concentration and machining conditions on MRR

Mohan et al. (2002) studied the effect of changing different parameters of an EDM like current, pulse duration, electrode material, rotation of electrode etc. on MRR, EWR, SR of a metal matrix composite of Si and Al. It was found that with an increase in the value of pulse duration the MRR decreased. The reason for this was more vaporization, expansion of plasma channel and due to this reason a decrease in the value of energy density for the work piece. The MRR for rotatory tool was noted to be very high as compare when stationary tool was used. The main reason for this was found to be effective flushing of rotating tool. Also the recast layer present on the machined surface causes lesser MRR. This recast layer was produced in case of stationary electrode because the melted metal particles remain suspended in to the gap and settled down on surface of machined part as recast layer. The TWR was also analyzed for all these factors. With increase in pulse duration, current and positive polarity, the amount of TWR was noted to be high. This is because, in all these three cases the value of MRR increased, which caused the amount of debris to increase and that directly affected the TWR. Due to all these reasons TWR increased. Another factor which they analyzed was the SR value. It was found that with an increase in the pulse duration the SR value lowered. This happened because of the broadening of the gap, which lowered the value of energy per spark and caused the shallow craters on the surface. But an increase in current increased the energy per spark which caused a higher SR, due to deeper cuts.

Ekmecki, (2007) has studied the effect of electrode type and dielectric liquid on white surface layer structure formed while working on EDM. It was found that the white layer which was formed during these works contained products from the broken dielectric medium and tools material. Some traces of martensite in austenite matrix were found, which causes this high hardness value of the white surface layer. The presence of residual stresses were also analyzed and this was noted that these stresses were produced due to non-homogeneity of heat flow and also they were present on surface layer in a very narrow range. Higher pulse energy caused them to increase to higher level. It was found that in case of kerosene as dielectric medium the surface of machined part got saturated with carbon. But when another dielectric medium de-ionized water were used with graphite as tool material than retained austenite was formed on surface. The depth of white recast layer for all the samples was found to be different. The amount of retained austenite on the surface was found to be high as compare to layers beneath surface layer. The residual stresses increased with increase in depth. This all happened due to the presence of heat affected zone beneath the white surface layer. Due to this heat affected zone their occurred a change in microstructure of material. This change produced residual stresses in material beneath the white surface layer.

Srivastava et al, (2012) compared the MRR, TWR and SR of cryogenically cooled ultrasonically vibration assisted EDM process with cryogenically cooled EDM (CEDM) and conventional EDM process. The parameters like current, OCV, pulse on time and duty cycle were varied to check the change in these results. It was found that with increase in current in case of UACEDM the MRR was higher as compare to conventional EDM process. The reason for this was, higher discharge energy available in case of UACEDM. The cooling of electrode resulted in lowering the temperature of dielectric medium in vicinity of tool, which resulted into longer time for dielectric to reach at higher temperature. This resulted in the availability of high heat for machining and also vibrating tool resulted more heated dielectric to come into the gap resulting easy melting of work material and higher MRR. An increase in duty cycle also caused higher MRR due to the availability of longer time for machining. MRR in case of UACEDM was noted higher than CEDM and EDM. The TWR was also analyzed and it was noted that with an increase in discharge current the value of TWR increased. This is because of the increase in discharge energy. An increase in pulse on time, caused a decrease in TWR, because with an increase in pulse duration the energy density of column was reduced due to widening of column. Also the deposition of carbon from broken dielectric caused an increase in wear resistance of the tool, which reduced its wear rate.

Singh et al. (2007) worked on graph theory technique, to know its advantages by implementing it on a manufacturing system. They firstly collected all the information about a manufacturing system, that which kind of activities different departments were involved. Then the interrelations between these departmental activities were found. After collecting all this information, an advanced technique known as graph theory technique were implemented on this collected information to study the manufacturing system as a whole. In this work they used different variable permanent functions, matrices etc. to break the whole system into sub groups, their characterization and analyzing them. The reason for implementing this approach was its ability to analyze a system as a whole. Earlier reported work had never studied a manufacturing system as a single unit. From these different matrices different functions were generated which were known as characteristics of systems. Different steps involved in this technique leads to the formation of a graph which showed all different combinations of subsystems. This graph can be used in a number of ways to analyze the whole system. After forming these graphs, coefficient of similarity and coefficient of dissimilarity were formed to compare two different manufacturing systems.

Prabhakaran et al. (2005) worked on composite products. The properties of these composite products were found and integrated to analyze them using graph theory approach. It was found that the fiber reinforced polymers were good for industrial purpose, because of their good mechanical properties. But the main problem was lack of full knowledge of the whole composite materials, which was creating hurdles in their use for industrial purpose. In this work different sub parts of a composite product system were found like resin type, reinforcement type, processing equipment, tooling system and product design. Different matrices were formed to analyze all these systems. From these matrices different multinomial were formed. These leads to the formation of a permanent multinomial function, from which a graph was produced to analyze the system for its strength, weakness, optimization etc. After this two coefficients named as coefficient of similarity and coefficient of dissimilarity were formed to compare two different composite systems.

Karthikeyan et al. (1997) optimized EDM characteristic like TWR, MRR, SR etc. by developing a mathematical model. Discharge current, OCV, pulse on time, volume fraction of SiC in MMC were taken as process parameters. The linear, interactive and quadratic effects of parameters were checked using this mathematical model. Finally ANOVA was applied on this to check the significance of these models. By analyzing the results it was found that the MRR decreased when volume fraction of SiC was increased. But MRR increased with an

increase in value. The TWR decreased with an increase in pulse duration but it increased with an increase in volume fraction of SiC and current value. The SR value showed an increasing trend when current, volume and pulse duration were increased. A number of combinations were found to be made to get the desired results.

Liew et al. (2013) studied the material migration trend in micro EDM by conducting experiments on reaction bonded SiC. The tungsten tool was found deposited with carbon atoms in discharge induced craters and also at surface. This deposition of carbon atoms on tool was due to the migration of carbon atoms from dielectric, workpiece and carbon nanotubes present in dielectric medium. By analyzing the machined surface it was found that a white layer of particle has been deposited. On further analysis of this layer it was found to be formed from tungsten particles which came from the tool. The effect of voltage on material deposition was also analyzed and it was found that an increase in voltage resulted in decrease in material deposition on both sides. This was found because that with an increase in voltage the working gap increased which resulted an easy removal of debris from the working gap, this resulted in lesser deposition on the surfaces. But when the voltage was reduced than the reverse phenomenon happened. The effect of capacitance on material deposition were also analyzed and it was found that with an increase in the capacitance value the size of particles deposited increased in every case. Also with a longer pulse duration with an increased capacitance value the amount of material deposition increased. It was found that with an increase in the percentage of carbon nano tubes in system the material deposition was reduced. This happened because of the reduced surface roughness value, which resulted in smaller craters for material deposition.

Mahardika et al. (2008) developed a new method to monitor the micro EDM process. In this work they mainly concentrated on number of pulses and also upon the total discharge energy to monitor this process. Also the different complications in EDM system like cavitation, short circuiting were taken care of. The tool wear compensation factor was successfully calculated for good results and higher accuracy. It was found that, by increasing the vibrations provided to tool resulted in decrease in adhesion, which resulted a shorter machining time. Some of the problems of micro EDM process were found like, difficulty in measuring the shape compensation of tool electrode, difficulty in finding the exact effect of different parameters upon outputs due to the stochastic thermal nature of micro EDM process. It was found that when machining of large craters were achieved, it resulted in an increase in number of pulses

and ultimately an increase in discharge energy was reported. These were found to be independent from the disturbance and only dependent upon MRR.

Prihandana et al. (2009) studied the effect of addition of micro powder particles and ultrasonic vibrations in micro EDM process. Powder used was MoS₂. The machining parameters which were used to analyze the system were powder concentration, work material, vibrations of dielectric fluid, and tool material. The main problem for a large machining time and poor surface finish was found to be the presence of debris in machining gap. By applying ultrasonic vibrations to dielectric fluid this problem of powder accumulation was solved and a good SF and shorter machining time were noted. The increased powder concentration from a specific level resulted in decrease in MRR due to the accumulation of powder particles in working gap. But when this was in range than it resulted in increase in MRR. This was because if increase in number of conductive particles in system. When powder was used in EDM system, a good surface finish was reported. When powder was added, it resulted an increasing working gap which caused small craters and good surface finish.

LITERATURE SUMMERY AND GAPS:

Summery:

- i) Increasing the current would cause greater MRR due to an increase in energy per pulse. (Yan et al. 2004)
- ii) An increase in electrode area would cause a damage to the surface due to increase in heterogeneities which would cause short circuiting. (Pecas et al.)
- iii) PMEDM has a greater efficiency or MRR and good surface finish as compared to EDM (Wang et al.)
- iv) It has been found out that an increase in powder concentration would increase the MRR but beyond a specific limit if concentration of powder is being than it would result in decrease in MRR due to starting of short circuiting.
- v) To get higher MRR when pulse on time is small work piece should be attached to +ve polarity & when pulse on time is large than with -ve polarity.

Gaps in work:

Some gaps are being identified in work done by different researchers till date. Our aim has been decided to fulfill this gap.

- i) Everyone has worked to find out the results of adding powder in EDM dielectric on different parameters like MRR, TWR, SR, Micro Hardness. But till today no any method has been developed which will give us the direct value of working parameters to get required MRR, TWR, SR & micro hardness.
- ii) Work has been performed on EDM system by considering all the factors separately. No work has been done on EDM by considering all the different subsystems of EDM at single time.

CHAPTER 3

METHODOLOGY

3.1) AIM OF STUDY:

The aim of our work is to formulate such a technique, by which a new person entering in this field can easily understand the working of EDM. In our work we performed a number of experiments to find out the effect of different parameters on final outputs. After finding these interrelations between these parameters and outputs, we implemented a new approach known as “GRAPH THEORY APPROACH” on these results. With the help of this technique we generated some graphs. From these graphs a person can easily find out that what kind of parameters he needs to get desired results. Also with the help of this technique, two different systems of EDM can be compared with each other.

Hence present work's aim is to:

1. Study the effect of different ferrous and nonferrous powders on MRR, TWR, SR.
2. Study the effect of changing different working parameters on MRR, TWR, SR.
3. Apply the GRAPH THEORY approach to find out the interrelations between these outputs and different parameters.

3.2) METHODOLOGY:

3.2.1 DESCRIPTION OF MACHINE

The experimentation work was conducted on T-3822 M EDM machine present in non-traditional machining lab at Thapar University, Patiala. A different arrangement was added for performing powder mixed EDM. Fig. 3.1 shows a view of machine with arrangement for powder mixed EDM with properly visible control panel and machining arrangement.

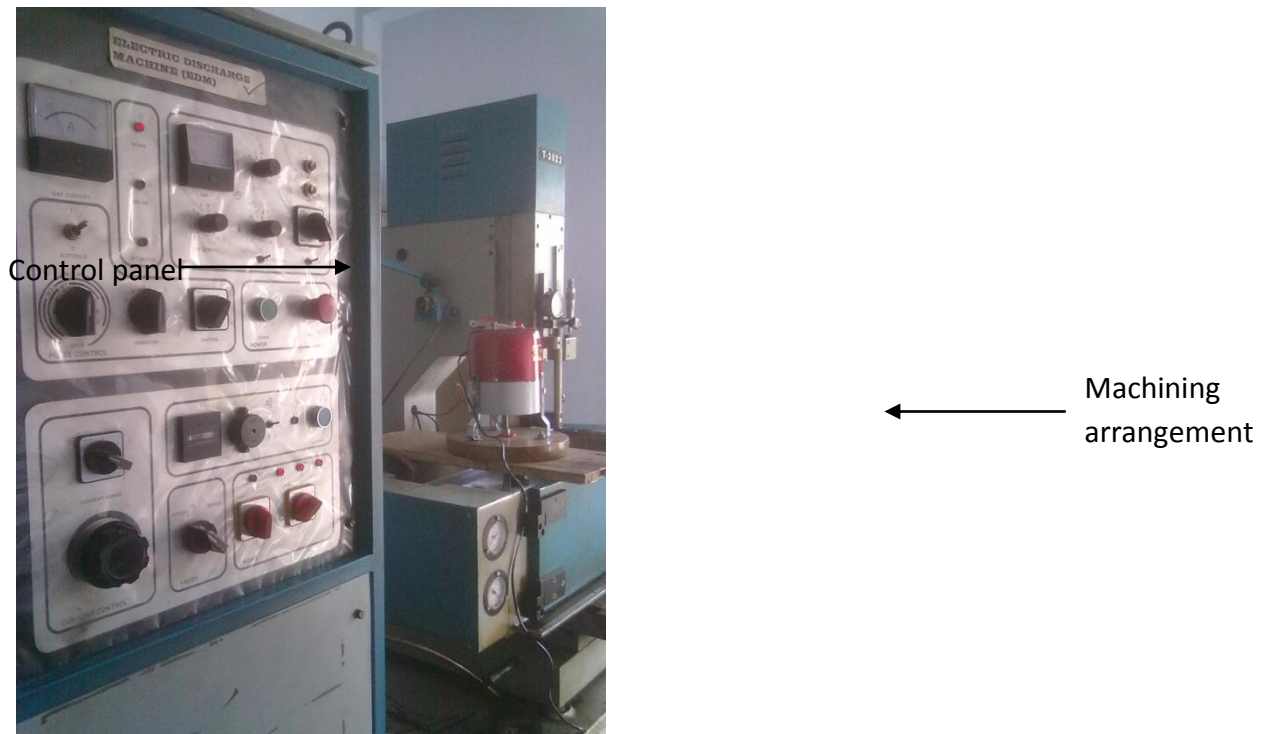

Fig. 3.1: EDM machine(Courtesy: NTM lab, Thapar University, Patiala)

3.2.2 Factors

Different factors needs to be decided before performing machining operation on EDM. These are:

- Various parameters of EDM
 - i) Type of dielectric flushing
 - ii) Discharge voltage
 - iii) Pulse configuration
 - iv) Polarity
 - v) Peak current
 - vi) Electrode gap
 - vii) Type of powder and powder concentration

- Work materials
 - i) H11
 - ii) AISID2

- Tool material:
 - i) Copper

- End requirements to be measured:
 - i) MRR
 - ii) TWR
 - iii) Surface finish
 - iv) Micro hardness

3.2.3 Experiment Design

In experimental design following points to be included:

- Deciding the factors which is to be studied i.e. peak current, pulse on duration, pulse off duration, dielectrics, metal powders and their concentration.
- Selecting suitable levels of each factor.

3.2.5) GRAPH THEORY APPROACH:

What is graph theory technique- This is an approach to analyze the system as a whole, by considering all different subsystems present in a system and also by finding the interrelations between these subsystems.

- **Selection of sub-systems.**
- **Finding of interrelations between them.**
- **Matrix formation**
- **Graphical representation**
- **Comparing two different systems**

Selection of subsystems -In every system a number of subsystems can be found on analyzing into depth. In this step the selections of different subsystems is done. These subsystems, when taken together will form the whole system. These are selected in such a way, that these can represent the whole system.

Finding the interrelations between subsystems-The next step is to find out all the relations between these subsystems. This is a very important step and must be performed with due care. Because the whole process now onwards will depend upon the interrelations selected.

Formation of adjacency matrix-An adjacency matrix is a square matrix in which whole information can be stored. In this matrix the whole information about the subsystems and the interrelations between them can be stored in matrix form.

Systems characteristics matrix- The adjacency matrix which we have, will show only the interrelationship between the subsystems. It would not represent the characteristics of this whole system. To solve this problem a new matrix named as “system characteristic matrix” will be created.

System characteristic and interdependence variable matrix- the “system characteristic matrix” formed earlier will not be able to give the correct information about the subsystems and relations between them. This is because of the property of matrix system, in which the rows and columns can be interchanged without changing the final value. To solve this problem this “EDM system characteristic and interdependence variable matrix” will be generated.

System characteristic and interdependence variable permanent matrix-In this matrix all the negative signs present in above matrix will be converted into positive signs. The reason to do this, is to save the desired information which could have been deleted due to many subtraction operations. To overcome this problem this matrix named as “system characteristic and interdependence variable permanent matrix” will be generated.

System characteristic and interdependence variable permanent function-to get the final numerical value of the whole system, the numerical values to each term will be assigned first and then, the determinant of this matrix will give a permanent function of this whole system.

Graphical representation of whole system- a number of different groups of subsystems can be seen in system characteristic and interdependent variable permanent matrix. This grouping can be represented in graphical form. This will help to understand the system as a whole very easily.

Comparison of different systems- the last step in this approach is to find out the best system for desired results. This can be done by comparing the numerical values obtained from above permanent function for two different systems. The coefficient of similarity and coefficient of dissimilarity” can be calculated for comparing two different systems.

3.3) WORK COMPLETED

3.3.1) purchased materials

1) Metal powder

Table (3.1): Details of purchased metal powder

S.no	Powder Material	Size(mesh)
1	Graphite	325
2	Aluminium	1000

2) Tool Material

Table (3.2): Details of purchased tool material

S.no	Material	Size(mm)
1	Copper	15

3) Work Material purchased

Table (3.3): Details of purchased work material

S.no	Material	Size(mm)
1	H11	100*60*10
2	AISI D2	100*60*10

3.3.2) Trial experiment conducted

Details

Work Material- H11 & AISID2

Tool Material- Copper

Dielectric- EDM oil

Powder- Graphite

Machining time- 5 min

Current- 8 amp



Fig (3.2). Machined work piece of D2

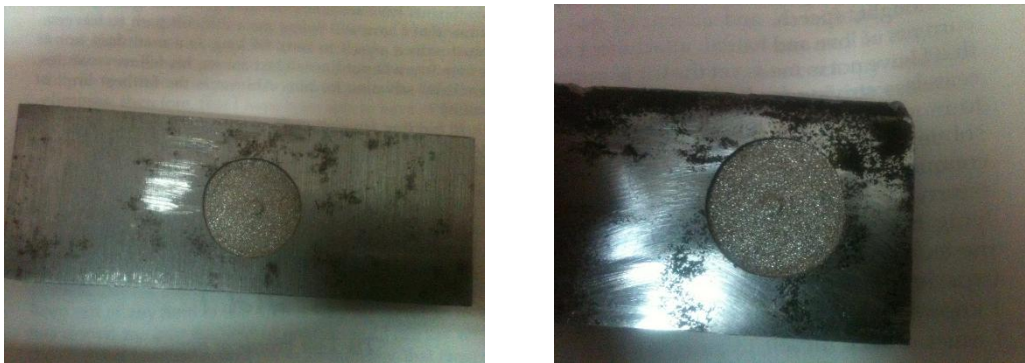

Fig (3.3). Machined workpiece of H11

3.3.3) Observation Table/Graphs:

S.no		H11			AISID2		
		Initial Wt. (gm)	Final Wt. (gm)	MRR (gm)	Initial Wt. (gm)	Final Wt. (gm)	MRR (gm)
1	Without using powder	280.220	279.380	0.84	281.630	281.080	0.55

2	With Graphite Powder	279.110	278.180	0.93	281.080	279.980	1.1

Table (3.4): Details of MRR obtained during experimentation

S.no	H11			AISID2		
	Initial Wt. (gm)	Final Wt. (gm)	TWR	Initial Wt. (gm)	Final Wt. (gm)	TWR
Without Powder	212.420	212.400	.02	212.440	212.420	.02
With graphite Powder	212.380	212.360	.03	212.400	212.380	.025

Table (3.5): Details of TWR obtained during experimentation

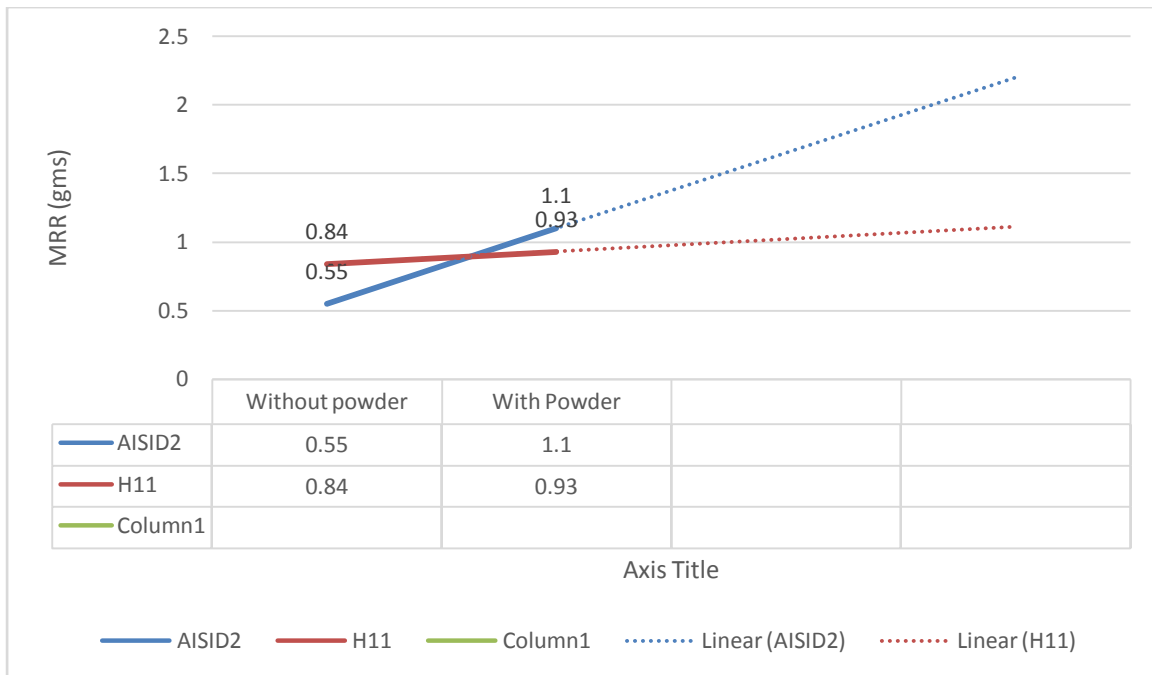

Fig (3.4). Plot of MRR for two different materials at two different conditions

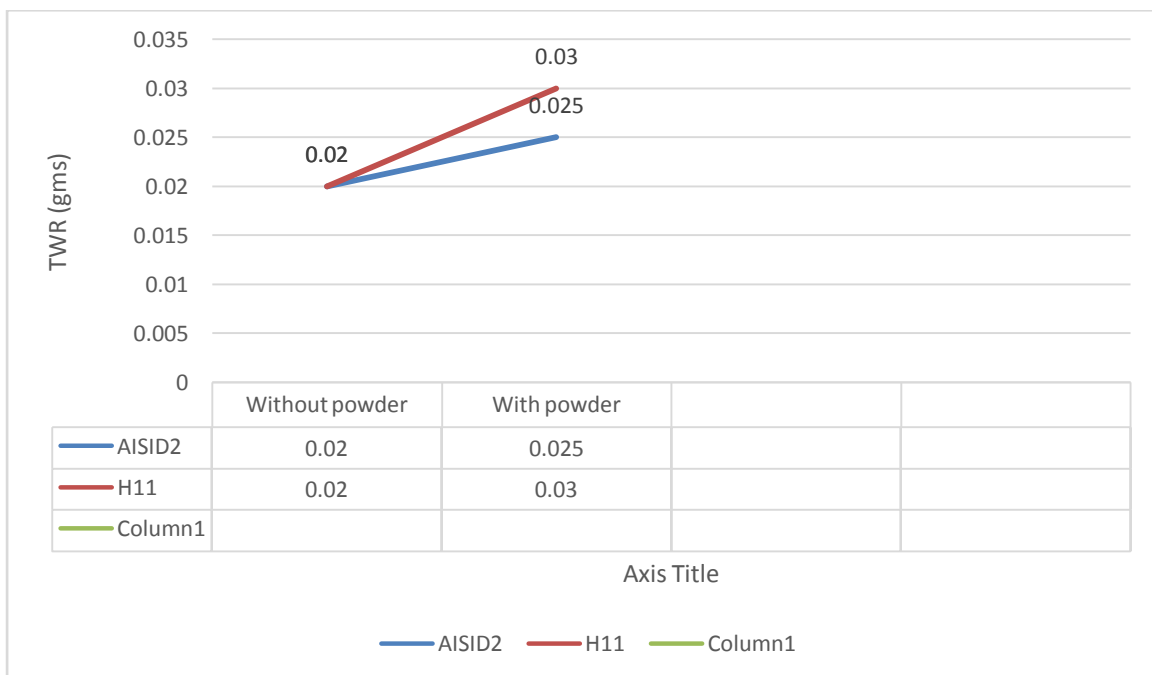

Fig (3.5). Plot for TWR for two different materials at two different conditions

3.3.4) Plot for surface roughness of work pieces.

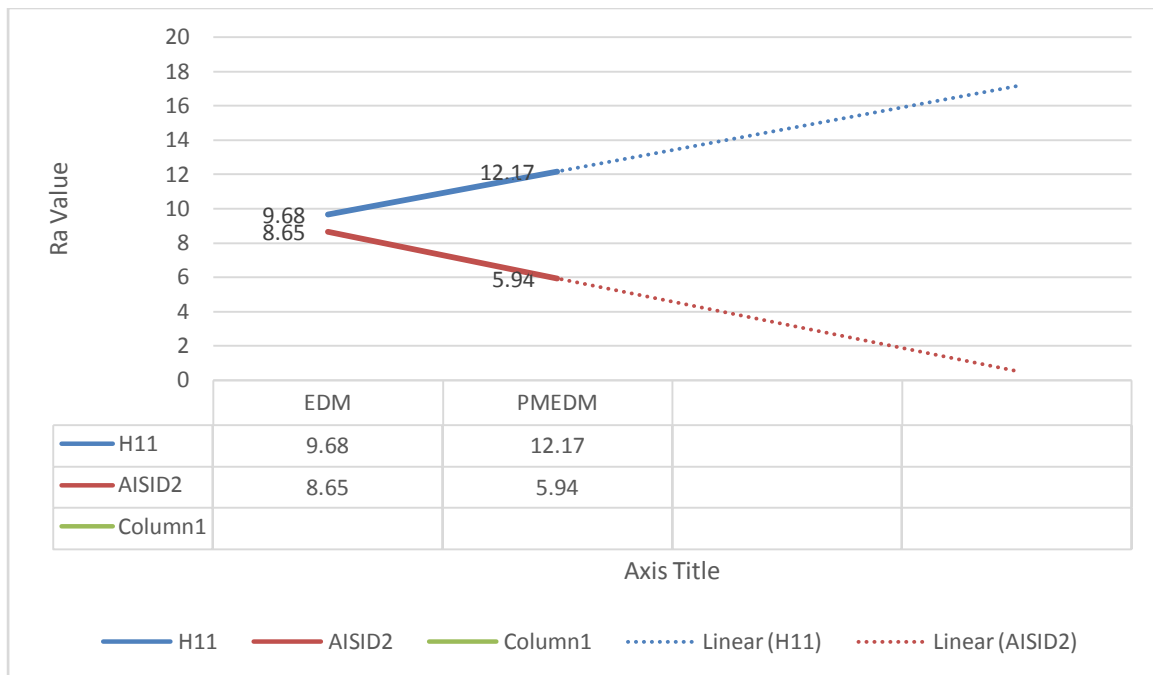

Fig (3.6):Plot for SR for two different materials at two different conditions

3.4) Conclusions

- i. In both the cases the MRR increased to a specific level.
- ii. The increase in MRR in case of AISID2 is greater as compare to H11 steel.
- iii. Tool wear rate (TWR) while machining without powder is same for both materials.
- iv. Tool Wear Rate increases when machining is done by mixing powder in EDM oil.
- v. Value of surface roughness for D2 improves by using PMEDM.
- vi. Value of surface roughness for H11 deteriorates while using PMEDM as compared to EDM.

CHAPTER 4

RESULTS AND DISCUSSION

4.1) GRAPH THEORY APPROACH-

In this chapter we have implemented and discussed the graph theoretic approach on EDM system. An EDM system can be divided into different number of subsystems as discussed below.

4.1.1) Subsystems of EDM-

For description of the methodology six subsystems have been identified namely performance, factors, work material, tool, EDM type, environment. These subsystems are general in nature which can represent all kind of EDM operations. The following sections discuss the importance of each of the identified subsystems of the EDM.

Performance

In this subsystem we mainly concern about the output results which can be obtained by using an EDM. These performances are mainly MRR, TER, SR, Surface Hardness, overcut, surface properties etc.

Input Factors

By factors we mainly mean those inputs which will change the final output result. These factors must be controlled carefully because a slight change in any of these would affect the final output. These factors are current, voltage, pulse frequency, pulse on time, pulse off time, polarity, gap between tool and work piece etc.

Work material

By work material we mean the all type of materials which are being used in EDM process. These materials are work specimen material, tool material, dielectric medium, type of powder etc. These work materials would affect the final results to a great extent if a slight change occur in these.

Tool

Tool plays an important role in EDM machining. Tool hardness, tool toughness, tool shape and tool material these all would affect the final output of process. A change in tool hardness would change the surface finish and MRR of the system. So this is very important to consider this subsystem here.

EDM Type

Type of EDM system being used is an important factor to consider to control the final output of system. In today's world wire cut EDM, simple EDM, Powder mixed EDM and magnetic field assisted EDM are being used. The all have different output results and different set parameters.

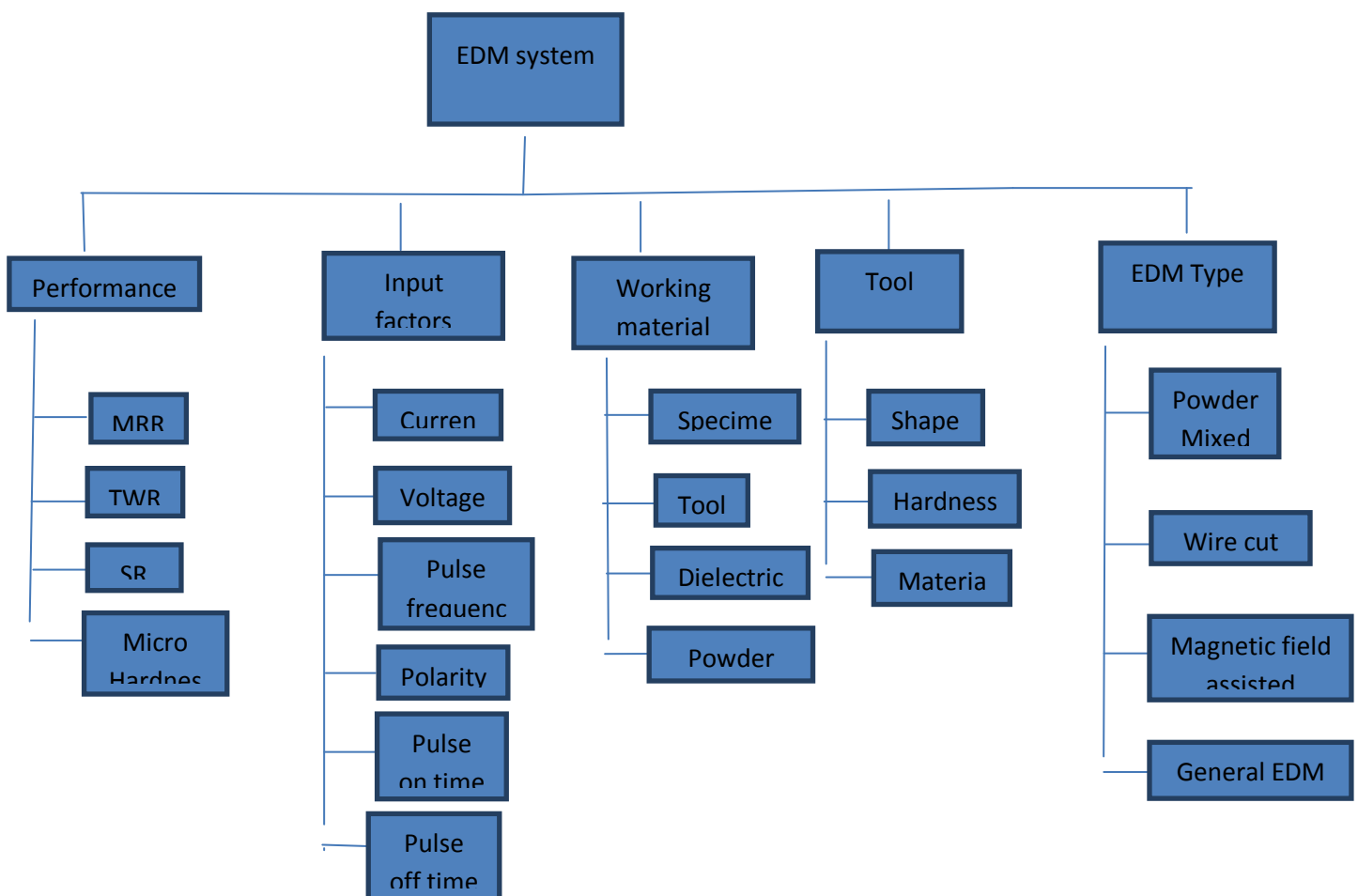

Fig. 4.1

EDM system tree diagram

4.1.2) Interactions in the subsystems of an EDM-

To find out the interactions between different subsystems of an EDM system, some experiments has been conducted to find out these interactions. The results are discussed below.

➤ **Experiments conducted**

1) Details

Work Material- H11 & AISID2

Tool Material- Copper

Dielectric- EDM oil

Powder- Aluminium

Machining time- 10 min

Current- 10 amp

Pulse off time- 40

Pulse on time- 150

➤ **Observation tables and graph for MRR-**

S.no	H11			AISID2			
	Initial Wt. (gm)	Final Wt. (gm)	MRR (gm)	Initial Wt. (gm)	Final Wt. (gm)	MRR (gm)	
1	Without using powder	308.40	306.45	1.95	291.110	289.170	1.94
2	With Aluminium Powder	311.170	309.170	2	284.820	282.810	2.01

Table (4.1): Details of MRR obtained during experimentation

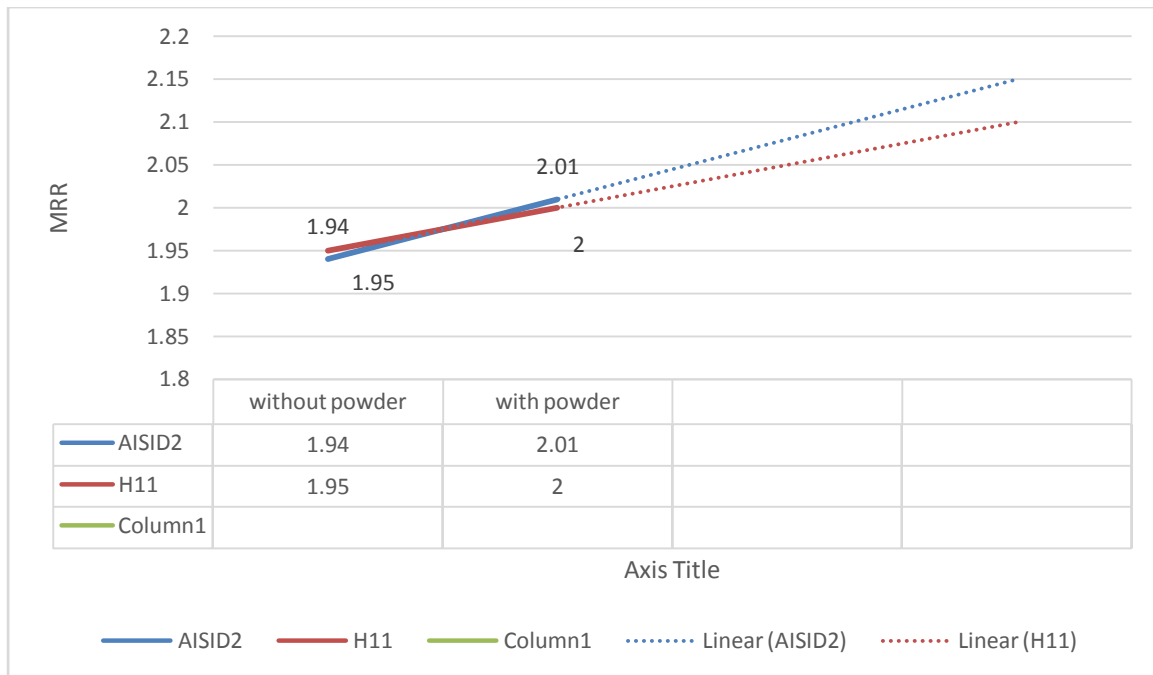

Fig (4.2). Plot for MRR for two different materials at two different conditions

➤ **Observation tables and graph for TWR-**

S.no		H11			AISID2		
		Initial Wt. (gm)	Final Wt. (gm)	TWR (gm)	Initial Wt. (gm)	Final Wt. (gm)	TWR (gm)
1	Without using powder	107.210	107.180	0.30	107.170	107.160	0.01
2	With Aluminium Powder	107.120	107.110	0.01	107.110	107.100	0.01

Table (4.2): Details of TWR obtained during experimentation

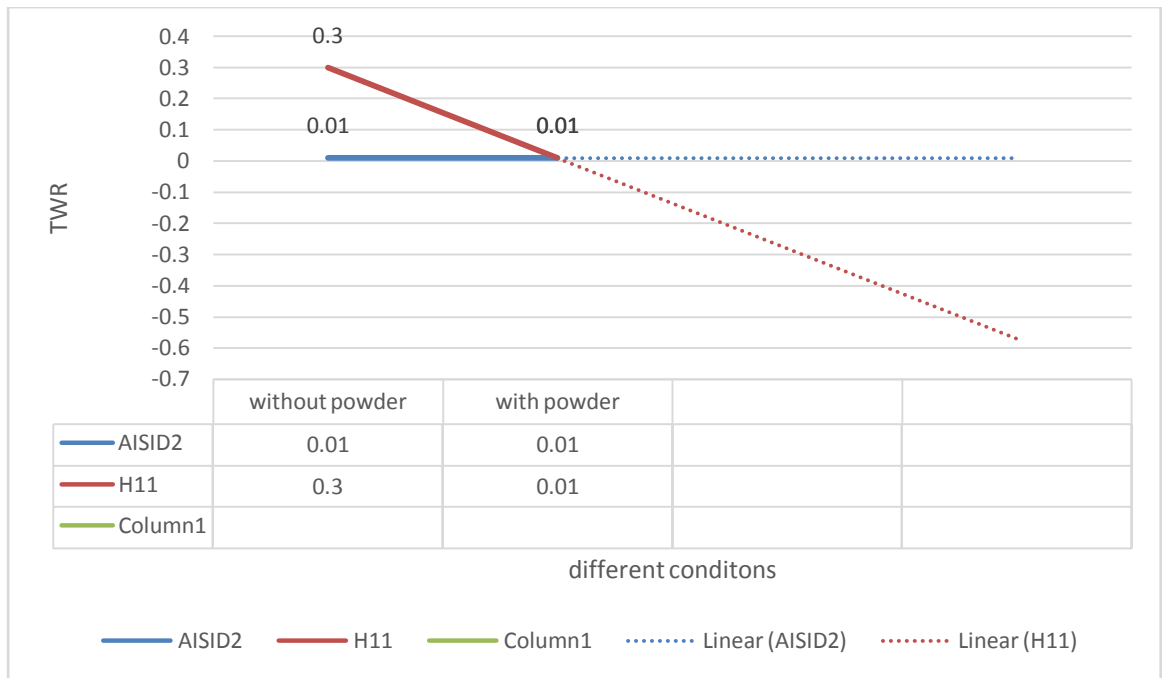

Fig (4.3). Plot for TWR for two different materials at two different conditions

➤ **Observation table and graph for surface roughness-**

S.no		H11			AISID2		
		Initial SR	Final SR	Difference	Initial SR	Final SR	Difference
1	Without using powder	0.75	7.07	6.32	0.81	6.86	6.05
2	With Aluminium Powder	0.68	6.91	6.23	0.63	5.42	4.79

Table (4.3): Details of SR obtained during experimentation

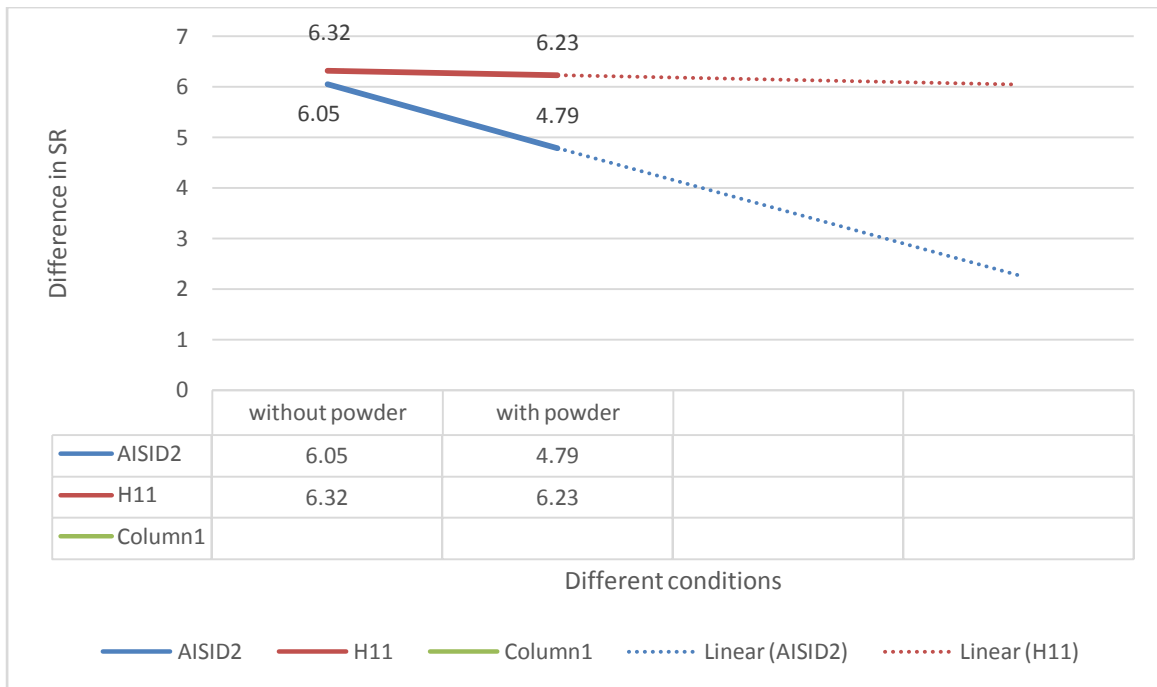

Fig (4.4). Plot for SR for two different materials at two different conditions

2) Details for another setup-

Work Material- H11 & AISID2

Tool Material- Copper

Dielectric- EDM oil

Powder- Aluminium

Machining time- 10 min

Current- 15 amp

Pulse off time- 40

Pulse on time- 200

Powder concentration- 10gm/ltr

➤ **Observation tables and graph for MRR-**

S.no		H11			AISID2		
		Initial Wt. (gm)	Final Wt. (gm)	MRR (gm)	Initial Wt. (gm)	Final Wt. (gm)	MRR (gm)
1	Without using powder	306.45	303.840	2.61	289.170	286.500	2.67
2	With Aluminium Powder	309.170	306.540	2.63	282.810	280.320	2.49

Table (4.4): Details of MRR obtained during experimentation

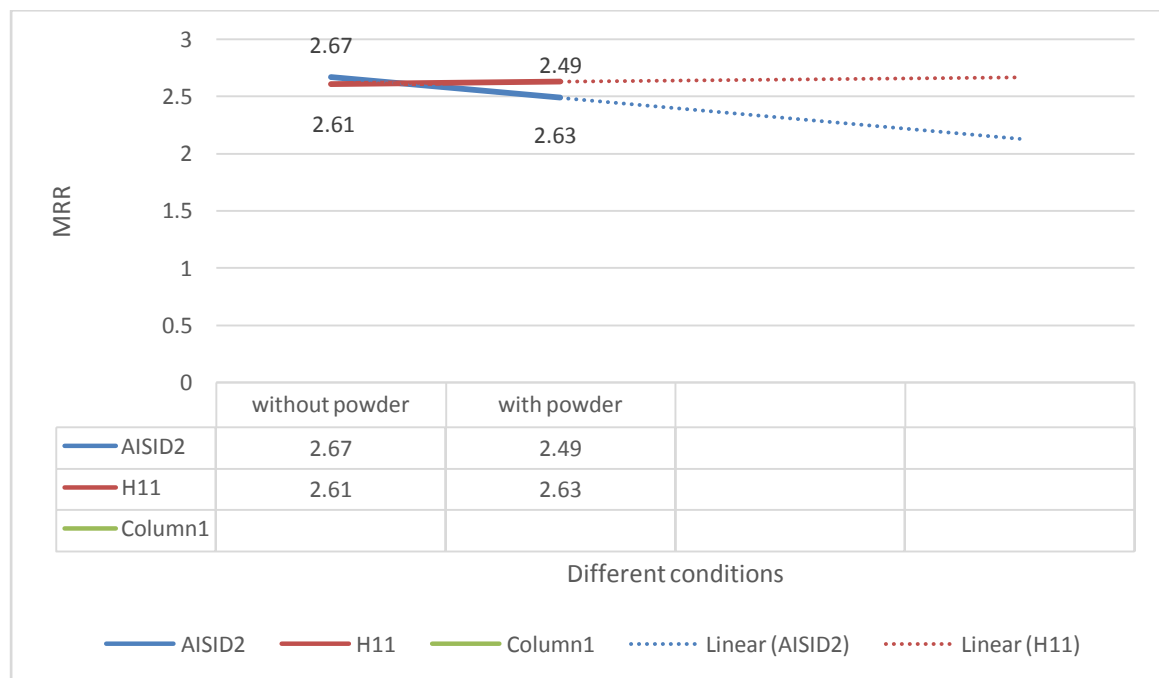

Fig (4.5). Plot for MRR for two different materials at two different conditions

➤ **Observation tables and graph for TWR-**

S.no		H11			AISID2		
		Initial Wt. (gm)	Final Wt. (gm)	MRR (gm)	Initial Wt. (gm)	Final Wt. (gm)	MRR (gm)
1	Without using powder	107.180	107.170	0.01	107.160	107.120	0.04
2	With Aluminium Powder	107.110	107.100	0.01	107.100	107.090	0.01

Table (4.5): Details of TWR obtained during experimentation

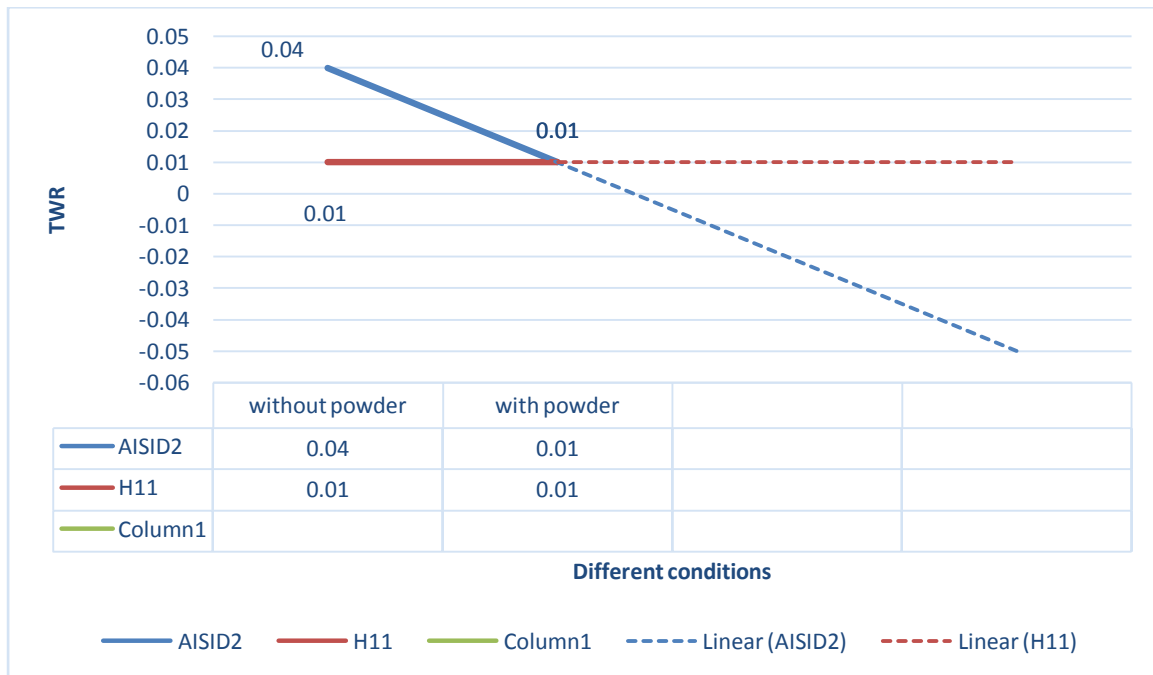

Fig (4.6). Plot for TWR for two different materials at two different conditions

➤ **Observation tables and graph for SR-**

S.no		H11			AISID2		
		Initial SR	Final SR	Difference	Initial SR	Final SR	Difference
1	Without using powder	0.75	8.29	7.54	0.81	11.42	10.61
2	With Aluminium Powder	0.68	8.83	8.15	0.63	9.68	9.05

Table (4.6): Details of SR obtained during experimentation

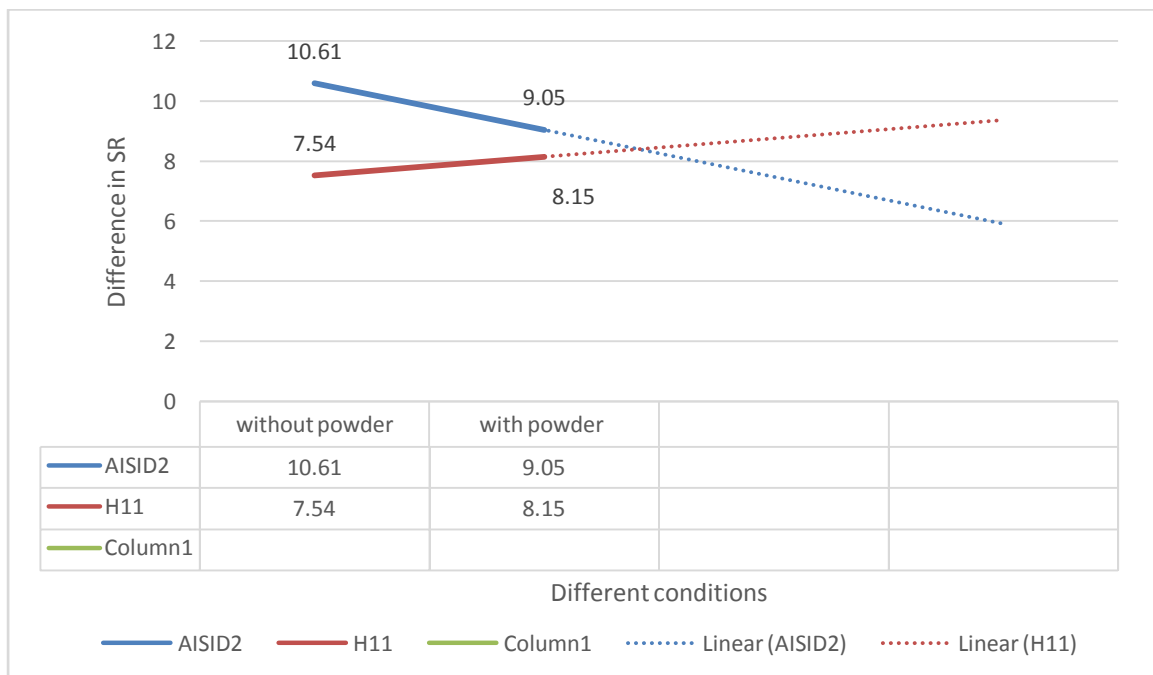

Fig (4.7). Plot for SR for two different materials at two different conditions

From the above results it is clear that, these subsystems affects each other. So from these results we found some of these interactions between these subsystems as discussed below.

Working material and factors- Type of dielectric material being used in machining operation would affect the open circuit voltage directly. An easy to break dielectric material

would require lesser voltage as compare to a dielectric which is not easily breakable. So from this example we can say that both factors and working materials would affect each other directly.

Performance and factors- Similarly performance and factors are also interrelated to each other and they would affect each other directly. For example if we require a good surface finish than input current range must be low. Input current should not be very high because a high current would lead to a poor surface finish and high surface roughness. Similarly polarity would affect the final performance of a machining operation. A work piece with positive polarity yields higher MRR as compare to a work piece on negative polarity.

Performance and work material- There is a relation between work material being used and final performance of the system. An easily breakable dielectric medium would give more time for machining and that would lead to an increase in the MRR of work material. Similarly there are a number of powder materials available in market which gives different surface finishes. So to get desired surface finish we need to choose a particular type of powder. So from above it is clear that both performance and work materials are interdependent.

Performance and tool- Tool size, tool area and tool shape, these all would affect the final performance of the system. Larger is the tool base area higher would be the MRR because due to larger area large no of sparks would be produced and these would lead to higher MRR and also at the same time higher TWR.

EDM structure and Performance- If we need a high MRR rate than type of EDM process which is being used does matters. A standard EDM machine would give lesser MRR as compare to a powder mixed EDM operation. Also the surface roughness obtained in case of standard EDM operation would be higher as compare to the surface roughness obtained by powder mixed EDM.

EDM structure and tool- Tool structure and shape would get changed according to the type of EDM machining operation being used. A standard EDM machine requires a tool of round or square shape. But in case of a wire cut EDM a wire is being used as a cutting tool.

4.1.3) Graph theoretic model implementation on an EDM system-

Today Graph theoretic approach is being implemented in many practical applications to make the working of a system very clear. Out of those applications some can be listed here like “Design for X-Ability of a mechatronic system (Kiran et al., 2011)”, “Structure modelling and analysis of composite product system (Durai Prabhakaran et al., 2005)”, “Modelling and analysis of manufacturing system (Singh and Agrawal, 2006) etc. From these applications it is quite clear that this Graph Theoretic modelling can be used for an EDM machining application also.

For this purpose a linear graph, G has been defined as a function of vertex set and edge set as $G=f(V, E)$, where V corresponds to a set of vertices $V=V_1, V_2, V_3, \dots, V_n$ etc. And E stands for a set of edges $E= e_{12}, e_{23}, \dots, e_{mn}$. (Singh and Agrawal, 2006).

Here in this case of an EDM machining system let subsystems are being denoted by vertices and the interactions between these subsystems are denoted by edges. The graph between these subsystems would be a directional graph, means two edges connecting the two subsystems but pointing towards in opposite direction would be different. This graph which we have prepared here is good for visual analysis of this whole EDM system.

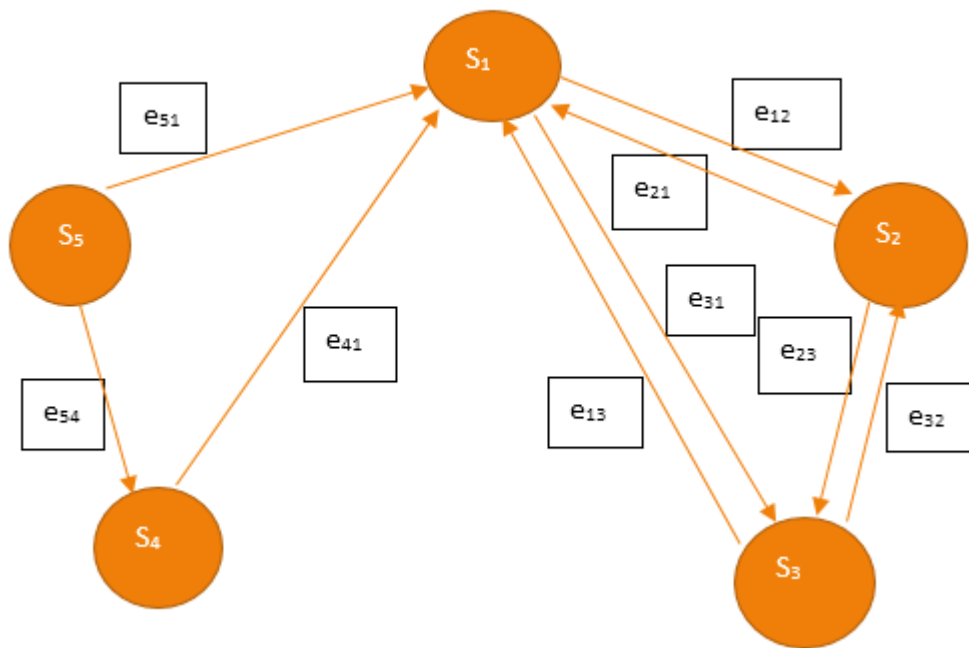

Fig. (4.8)

Graphical presentation of EDM

But for analysing this system with the help of a computer system, we have to adopt a different technique, because a computer system needs a different kind of information to

analyse the whole system. For achieving this objective we need to store this whole information in the form of matrix.

➤ **Matrix representation for EDM:**

To start with first we need to elaborate what an Adjacency matrix is. An adjacency matrix is a square matrix in which whole information can be stored. The adjacency matrix with five nodes would be a five order binary (0, 1) matrix, $A = [a_{ij}]$

$$a_{ij} = \begin{cases} 1, & \text{if both subsystems are interlinked} \\ 0, & \text{if both subsystems are not interlinked} \end{cases}$$

where $i, j \in \{1, 2, 3, 4, 5\}$ and $i = j$ /

Thus for this EDM system an adjacency matrix, A can be drawn from the above graph as given below:

$$A = \begin{bmatrix} 0 & 1 & 1 & 0 & 0 \\ 1 & 0 & 1 & 0 & 0 \\ 1 & 1 & 0 & 0 & 0 \\ 1 & 0 & 0 & 0 & 0 \\ 1 & 0 & 0 & 1 & 0 \end{bmatrix}$$

➤ **EDM systems characteristic matrix:**

The adjacency matrix A which we have, will show only the interrelationship between the subsystems. It would not represent the characteristics of this whole EDM system. To solve this problem we would now create a new matrix B named as “EDM system characteristic matrix.” (Singh and Agrawal, 2006).

$$B = [\lambda I - A] = \begin{bmatrix} \lambda & -1 & -1 & 0 & 0 \\ -1 & \lambda & -1 & 0 & 0 \\ -1 & -1 & \lambda & 0 & 0 \\ -1 & 0 & 0 & \lambda & 0 \\ -1 & 0 & 0 & -1 & \lambda \end{bmatrix}$$

Here \mathbf{I} is the identity matrix of the same order as of \mathbf{A} and λ represents the Eigen values for a matrix.

This matrix \mathbf{B} which is EDM system characteristic matrix cannot be considered as an invariant, because in normal matrix operations rows as well as columns can be interchanged without affecting any change in values of a matrix. So this matrix \mathbf{B} cannot be considered as a unique representative of the interactions between the subsystems of an EDM system (Singh and Agrawal, 2006). But the determinant of a matrix with a particular arrangement of rows and columns would give a specific value which would get changed with change in the arrangement of rows and columns. So here we would find out the determinant of matrix \mathbf{B} which would lead to an invariant of this matrix \mathbf{B} .

$$\text{Det}(\mathbf{B}) = \lambda^5 - 3\lambda^3 - 2\lambda^2$$

This determinant of the “EDM system characteristic matrix” is an invariant for this matrix \mathbf{B} . But this cannot be used directly to find out the characteristic of EDM system directly because of its unable ness to distinguish between subsystems as well as levels of interaction between them. To solve this problem another matrix named as “EDM system characteristic and interdependence variable matrix” needs to be created a given below.

➤ **EDM system characteristic and interdependence variable matrix:**

This “EDM system characteristic and interdependence variable matrix” has been created to solve the above problem and this matrix would be denoted by \mathbf{C} . To create this \mathbf{C} matrix, first we need to create two different matrices named as \mathbf{D} and \mathbf{E} matrices. \mathbf{D} is a diagonal matrix with diagonals representing different subsystems. Another five order matrix \mathbf{E} is a square matrix and its off diagonal elements represent different interactions between these subsystems.

$$\mathbf{C} = [\mathbf{D} - \mathbf{E}] = \begin{bmatrix} S1 & -e12 & -e13 & 0 & 0 \\ -e21 & S2 & -e23 & 0 & 0 \\ -e31 & -e32 & S3 & 0 & 0 \\ -e41 & 0 & 0 & S4 & 0 \\ -e51 & 0 & 0 & -e54 & S5 \end{bmatrix}$$

This matrix will represent the characteristic features of subsystems and interactions between them. But as discussed earlier due to matrices property of interchangeability of rows and

columns without any effect on matrix values. The determinant of this matrix would give us the desired results as it would be an invariant of the EDM system. Its name would be “EDM system characteristic and interdependence variable multinomial.”

$$\text{Det}(C) = S_1S_2S_3S_4S_5 - S_1S_4S_5e_{23}e_{32} - S_3S_4S_5e_{12}e_{21} - S_4S_5e_{12}e_{31}e_{23} - S_4S_5e_{13}e_{21}e_{32} - S_2S_4S_5e_{13}e_{31}$$

➤ **Composite performance index and the permanent function:**

To analyse the performance of an EDM system a composite score in a performance dimension may serve well. But to get this score we have to assign numerical values to the system variables in above equations. But these values may get deleted due to many subtraction operations, which would finally lead to missing of some important information of an EDM system. To overcome this, a permanent matrix and a permanent function is required to be used (Singh and Agrawal, 2006).

➤ **EDM system permanent matrix:**

When all the negative signs in the previous matrix C are converted into the positive signs than a new matrix will be formed and that matrix would be known as “EDM system characteristic and interdependence variable permanent matrix (EDMDPM).” This matrix would be represented by **P** as shown below.

$$P = \begin{bmatrix} S_1 & e_{12} & e_{13} & 0 & 0 \\ e_{21} & S_2 & e_{23} & 0 & 0 \\ e_{31} & e_{32} & S_3 & 0 & 0 \\ e_{41} & 0 & 0 & S_4 & 0 \\ e_{51} & 0 & 0 & e_{54} & S_5 \end{bmatrix}$$

➤ **EDM system characteristic and interdependence variable permanent function:**

The permanent function which is represented by Per (P) can be obtained by finding the determinant of permanent matrix. This permanent function Per (P) and the multinomial, det (C) are same except the signs in them. The advantage of this permanent model over the previous model is that, this model represents the structure of an EDM system completely with

an additional advantage of adding numerical values to each term without losing any important information.

$$\text{Per (P)} = S_1S_2S_3S_4S_5 + S_1S_4S_5e_{23}e_{32} + S_3S_4S_5e_{12}e_{21} + S_4S_5e_{12}e_{31}e_{23} + S_4S_5e_{21}e_{13}e_{32} + S_2S_4S_5e_{13}e_{31}$$

The value of the permanent function Per (P) which we get by putting all the numerical values to individual structural element can be considered as composite score of the EDM system. Based on this score we can compare different systems.

➤ **Structural analysis of EDM system:**

The different elements of this permanent consists of different subsystems and different interactions between them. The existence of terms in the form like $e_{12}e_{21}$, $e_{12}e_{23}e_{31}$ shows that the subsystems interact with each other in the form of loops. Each term can be divided into subgroups depending upon the type of elements present in it. These different sets can be used to characterise the EDM system uniquely.

First group	
Second group	No any element present
Third group + 2 more terms	
Fourth group + 1 more term	

Fig. (4.9). Structural analysis of an EDM system

Identification and comparison of EDM system structure:

The characteristic features of different structural members which are shown above can be summarized as below:

- 1) The first group consists of five independent subsystems. These are not interdependent upon each other. They can be identified as $S_1/S_2/S_3/S_4/S_5$.
- 2) The second group doesn't contain any term for this specific case. It might have for some another case.
- 3) The third group has three terms with three subsystems independent and two another subsystems in a loop. They can be identified as $S_i/S_j/S_k/S_{lm}$.
- 4) The fourth group has two terms with two subsystems independent from any another subsystem and another three subsystems are in loop with each other. They can be identified as $S_i/S_j/S_{klm}$.
- 5) The fifth group is again empty. It may contain another terms for some specific case. If present it would be shown like S_i/S_{jklm} .

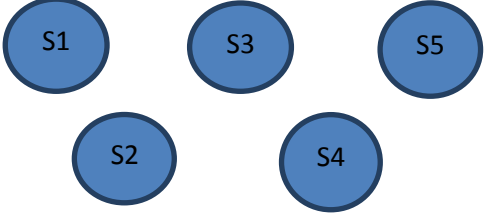
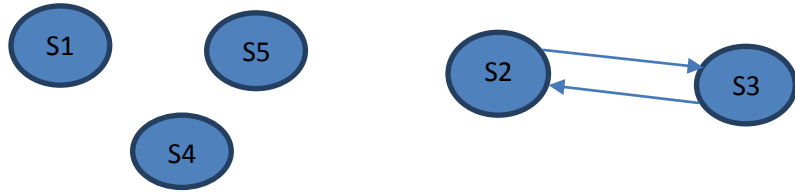
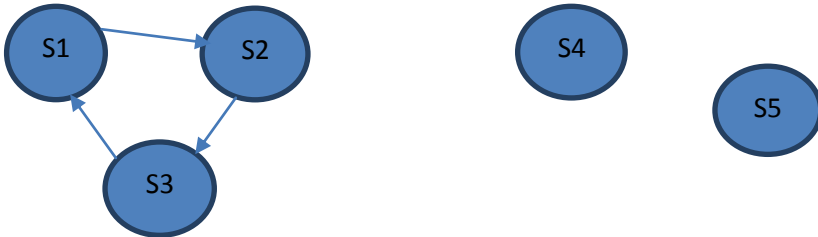
Thus it can be said that these different terms in permanent function can be used to compare different EDM systems in different conditions. This structural comparison between two systems would help to identify the best system required for a particular application. We have two different coefficients named as coefficient of similarity (COS) and coefficient of dissimilarity (COD). These coefficients would aid in comparing different systems.

There are two criteria's to find out these two coefficients. First of all we need a clarification on one notation i.e. J_{kl} . This J_{kl} denotes the total number of terms in l_{th} subgrouping of k_{th} group. Similarly J'_{kl} shows total number of terms for second case under consideration. Now we will discuss two criteria's to find out these coefficients.

- 1) **First Criterion:** In this case we have to find out the difference in number of terms in groups discussed above i.e. J_{kl} and J'_{kl} .

$$\alpha_{kl} = [J_{kl} - J'_{kl}]$$

Coefficient of dissimilarity (COD), $C_{d-1} = 1/X_1 \sum_k \sum_l \alpha_{kl}$

Here:

$$\mathbf{X}_1 = \text{maximum} [\sum_k \sum_l \mathbf{J}_{kl} \text{ and } \sum_k \sum_l \mathbf{J}'_{kl}]$$

The above criteria is good and very simple to find out the COD, but as α_{kl} may be negative due to the subtraction operation between two terms, it might lead to the elimination of some important information. So to solve this problem we have another method to find out this COD.

2) **Second criteria:** in this case we do

$$\text{COD, } C_{d-2} = [1/X_2 \sum_k \sum_l \alpha_{kl}^2]^{1/2}$$

Here:

$$\mathbf{X}_2 = \text{maximum} [\sum_k \sum_l \mathbf{J}_{kl}^2 \text{ and } \sum_k \sum_l \mathbf{J}'_{kl}^2]$$

The values of COD would lie between 0 and 1. The coefficient of similarity (COS) can be calculated directly from this COD by subtraction operation.

$$C_{s-1} = 1 - C_{d-1}$$

$$C_{s-2} = 1 - C_{d-2}$$

The values of COS would tell us about the similarity between two systems. If COS's value is 1 than it means that both the systems are similar in all ways and a value of 0 shows that both the systems are dissimilar 100 percent.

➤ **Generalization of permanent function model:**

If we are considering a general case of EDM system N number of subsystems than the independent permanent matrix "Z" for this system may be written as given below -

$$Z = \begin{bmatrix} S1 & e12 & e13 & \dots & e1N \\ e21 & S2 & e23 & \dots & e2N \\ e31 & e32 & S3 & \dots & e3N \\ \dots & \dots & \dots & \dots & \dots \\ eN1 & eN2 & eN3 & \dots & SN \end{bmatrix}$$

If we are talking about a general system with N subsystems and all these are interconnected with each other than the total number of elements in a permanent function shall be equal to N!. The permanent multinomial for this case may be written as given below-

$$\text{Per}(\mathbf{Z}) = \sum_i^N S_i + [\sum_i \sum_j \sum_k \dots \sum_N e_{ij} e_{ji} S_k \dots S_N] + [\sum_i \sum_j \sum_k \sum_l \dots \sum_N e_{ij} e_{jk} e_{kl} S_l \dots S_N] + [\sum_i \sum_j \sum_k \sum_l \dots \sum_N e_{ij} e_{jk} e_{kl} e_{li} S_m S_n \dots S_N] + \dots$$

The above form is a general form of a permanent multinomial function. It would vary case by case. Suppose in a particular case there is no interaction between two particular types of subsystems, then we can assign 0 to that particular interrelation in this general form and we will get the final correct permanent multinomial for that particular system. This would help in developing the graphs which we have drawn earlier to compare two different systems, thus helping in a visual analysis of the whole system.

4.2) Usefulness of this methodology-

- From the terms of a permanent multinomial a new user can easily find out the different subsystems which will effect each other and will affect the final result.
- Depending upon the requirements a person can select different parameters for securing the best results.
- By assigning the values to the terms in permanent multinomial we can find out the total score for a particular system and we can compare two systems for required results.
- To compare different systems we can use coefficient of similarity and coefficient of dissimilarity developed in this system.
- A computational analysis can be carried out using this methodology. This will result in to development of a software tool for the selection of optimum parameters for obtaining the best results.

Conclusions-

The methodology which were used in this work has the capability to interlink different subsystems of a system and can compare the best results for that system.

- The permanent function developed in this methodology is a mathematical model which has the capability of characterizing the EDM system uniquely and it can also identify different structural patterns and thus helps in systematic comparison of different system structures.
- The numerical values obtained from the permanent function can be very helpful in comparing two different systems and to develop a benchmark system.
- The COD and COS can be used to compare two different systems and this will help in evolving a system best suited for obtaining particular results.
- The best part of this methodology is that it consider all the subsystems of a system at one place and after considering all these subsystems, it will give the final numerical value for that system.
- One another advantage of using this system is that, in this system we take opinion from the experts and then assign scores to different subsystems parameters. This helps in including the expert's opinion in the final results thus giving weightage to the expert's opinions.

This is a small effort to make working of an EDM system more comprehensive and to compare different system with each other to get best results for particular requirements. The work is under progress to implement this methodology on another fields also.

CHAPTER 5

REFERENCES

- 1) Yan, B.H., Tsai, H.S., Huang, F.Y., 2004, The effect in EDM of a dielectric of a urea solution in water on modifying the surface of titanium, *Journal of Machine Tools and Manufacturing*, 45, 194-200
- 2) Pecas, P., Henriques, E., 2008, EDM Using simple and Powder Mixed Dielectric: The Effect of The Electrode Area In The Surface Roughness And Topography, *Journal Of Material Processing Technology*, 200, 250-258
- 3) Zhao, W.S., Meng, Q.G., Wang, Z.L., 2002, The Application of Research On Powder Mixed EDM In Rough Machining, *Journal Of Material Processing Technology*, 129, 30-33
- 4) Chow, H.M., Yang, L.D., Lin, C.H., Chen, Y.F., 2008, The Use Of SiC Powder In Water as Dielectric For Micro-Silt EDM Machining, , *Journal Of Material Processing Technology*, 195, 160-170
- 5) Wong, Y.S., Lim, L.C., Rahuman, I., Tee, W.M., Near Mirror Finish Phenomenon in EDM Using Powder Mixed Dielectric, *Journal Of Material Processing Technology*, 79, 30-40
- 6) Kansal, H.K., Singh, S., Kumar, P., 2007, Effect Of Si Powder Mixed EDM on Machining Rate Of AISID2 Die Steel, *Journal Of Manufacturing Processes*, 9, 1
- 7) Luis, C.J., Puertas, I., Villa, G., Material Removal Rate And Electrode Wear Study on the EDM of Silicon Carbide, *Journal Of Material Processing Technology*, 164-165, 889-896
- 8) Kumar, S., Batra, U., 2012, Surface Modification Of Die Steel Materials by EDM Method Using Tungsten Powder Mixed Dielectric, *Journal Of Manufacturing Processes*, 14, 35-40
- 9) HuF.Q., Cao, F.Y., Song, B.Y., Hou, P.J., Zhang, Y., Chen, K., Wei, J.Q., 2013, Surface Properties of SiC/Al Composite by Powder Mixed EDM, *Procedia CIRP*, 6, 101-106
- 10) Ming, Q.Y., He, L.Y., 1995, Powder Suspension Dielectric Fluid For EDM, *Journal Of Material Processing Technology*, 52, 44-54
- 11) Prihandana, G.S., Mahardika, M., Hamdi, M., Wong, Y.S., Mitsui, K., 2009, Effect Of Micro Powder Suspension and Ultrasonic Vibrations of Dielectric Fluid in Micro EDM Processes, *Journal of Machine Tools and Manufacture*, 49, 1035-1041

- 12) Ekmekci, B., 2007, Residual Stresses and White Layer in EDM, *Applied Surface Science*, 253, 9234-9240
- 13) Mohan, B., Rajadurai, A., Satyanarayana, K.G., 2002, Effect Of SiC and Rotation of Electrode On Electric Discharge Machining of Al-SiC Composite, *Journal Of Material Processing Technology*, 124, 297-304
- 14) Sharakhovsky, L.I., Marotta, A., Essiptchouk, A.M., 2006, Model of Workpiece Erosion for EDM Process, *Applied Surface Science*, 253, 797-804
- 15) Lui, Y.H., Ji, R.J., Yu, L.L., Zhang, H.F., Li, Q.Y., 2008, Effect of Machining Fluid on the Process Performance of EDM of Insulating Al₂O₃ Ceramic, *Journal of Machine Tools and Manufacturing*, 48, 1030-1035
- 16) Mahardika, M., Mitsui, K., 2008, A new Method For Monitoring Micro-Electric Discharge Machining Processes, *Journal of Machine Tools and Manufacturing*, 48, 446-458
- 17) Ekmekci, B., Tekkaya, A.E., Erden, A., 2006, A Semi Empirical Approach for Residual Stresses In EDM , *Journal of Machine Tools and Manufacturing*, 46, 858-868
- 18) Tsai, K.M. and Wang, P.J., 2001, Predictions on surface finish in electrical discharge machining based upon neural network models, *International Journal of Machine Tools & Manufacture*, 41(10), 1385–1403
- 19) Kuneida, M., Lauwers, B., Rajurkar, K.P. and Schumacher, B.M., 2005, Advancing EDM through fundamental insight into the process, *Annals of CIRP*, 54(2), 599–622
- 20) Fuller and John, E., 1996, Electrical Discharge Machining, *ASM Machining Handbook*, 16, 557–564
- 21) Bruyn and De, H. E., 1968, Slope control: A great improvement in spark erosion, *Annals of the CIRP*, 16, 183–186
- 22) McGeough, J.A., 1988, Advanced Methods of Machining, *1st ed. Chapman and Hall, USA, ISBN, 0-412-31970-5*
- 23) Wong, Y.S., Lim, L.C. and Lee, L.C., 1995, Effect of flushing on electro-discharge machined surfaces, *Journal of Materials Processing Technology*, 48, 299–305
- 24) Mahardika, M., Mitsui, K., 2008, A new method for monitoring micro EDM processes, *International General of Machining Tools and Manufacture*, 48, 446-458

- 25) Liew, J.P., Yan, J., Kuriyagawa, T., 2013, Experimental investigation on material phenomena in micro EDM of reaction bonded SiC, *Applied Surface Science*, 276, 731-743
- 26) Karthikeyan, R., Narayanan, P.R.L., Naagarazan, R.S., 1999, *Journal of Material Processing Technology*, 87, 59-63
- 27) Prabhakaran, R.T., Babu, B.J., Agrawal, V.P., 2005, Structural modeling and analysis of composite product system a graph theoretic approach, *Journal of Composite Materials*, Vol.40, 22
- 28) Singh, V., Agrawal, V.P., 2007, Structural modelling and analysis of manufacturing systems using graph theoretic approach, *Journal Of Manufacturing Technology*, vol 19, 844-870
- 29) Srivastava, V., Pandey, P.M., 2012, Effect of process parameters on performance of EDM process with ultrasonic assisted cryogenically cooled electrode, *Journal of Manufacturing Processes*, 14, 393-402
- 30) Ekmecki, B., 2007, Residual stresses and white in EDM, 2007, *Applied Surface Science*, 253, 9234-9240
- 31) Kira, C.P., Clement, S., Agrawal, V.P., 2011, Design for X ability of a mechatronics system- A concurrent engineering and graph theoretic approach, vol 19, 1

WEB REFERENCES:

<http://en.wikipedia.org><http://www.themetallurgist.co.uk><http://nptel.iitm.ac.in><http://technoccul.t.net>

<http://link.springer.com>