

# **ENVIRONMENTAL IMPACT ASSESSMENT IN A SECONDARY METALLURGICAL INDUSTRY WITH RESPECT TO AIR POLLUTION**

*A Thesis Submitted in Fulfillment of the  
Requirement for the Award of Degree of*

**Masters of Technology**

**In**

**ENVIRONMENT SCIENCE AND TECHNOLOGY**

*Submitted by*

**KANWARPAL SINGH**

**601601012**

*Under The Guidance Of*

**DR. ANOOP VERMA**

**Associate Professor**

(School of Energy and Environment,  
Thapar Institute of Engineering and  
Technology, Patiala)

**MR. SUMITAVA DUTTA**

**Dy. Technical Manager**

CPTL, Mohali



**THAPAR INSTITUTE**  
OF ENGINEERING & TECHNOLOGY  
(Deemed to be University)

SCHOOL OF ENERGY AND ENVIRONMENT  
THAPAR INSTITUTE OF ENGINEERING & TECHNOLOGY  
(A DEEMED TO BE UNIVERSITY), PATIALA, PUNJAB  
JUNE 2018

## DECLARATION CUM CERTIFICATE

I hereby declare that the project work entitled "Environment Impact Assessment in a Secondary Metallurgical Industry with respect to Air Pollution" is an authentic record of my own work carried out at M/s Chandigarh Pollution Testing Laboratory, Mohali as Requirements of one year project Internship for the award of Degree of M.Tech Environment Science and Technology, Thapar Institute of Engineering and Technology (Deemed to be University), Patiala, Punjab. Under the Guidance of Mr. Sumitava Dutta and Dr. Anoop verma. During the period of July 2017 to June 2018.

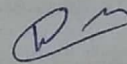

KANWARPAL SINGH  
(601601012)

Date :- 26/06/2018

Certified that the above statement made by the student is correct to best of our Knowledge and belief.

Faculty Coordinator :-

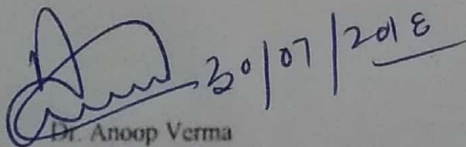

Dr. Anoop Verma  
Assistant Professor

M/s CPTL Coordinator :-

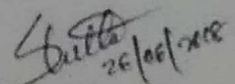

Mr. Sumitava Dutta  
Dy. Technical Manager

Sumitava Dutta  
Deputy Technical Manager  
Chandigarh Pollution Testing Lab

## ACKNOWLEDGEMENT

I would like to express my deepest appreciation to all those who provided me the possibility to complete this report. A special gratitude I give to the internal guide Dr. Anoop Verma and Industrial Coordinator Mr. Sumitava Dutta, whose contribution in stimulating suggestions and encouragement, helped me to coordinate my project especially in writing this report. Furthermore I would also like to acknowledge with much appreciation the crucial role of the staff of CPTL Mohali, who gave the permission to use all required equipments and the necessary materials to complete the task. I also thanks my classmates for their help .I have to appreciate the guidance given by other supervisor as well as the panels especially in our project presentation that has improved our presentation skills thanks to their comment and advices.

Kanwarpal Singh  
(601601012)

## **ABSTRACT**

In this project work the environment impact assessment of a secondary metallurgical industry situated near mandi gobindgarh town is studied primarily focusing on ambient air pollution. First of all the sites are selected for the monitoring purpose on the bases of guidelines, obtained meteorological data and our requirement. Sampling for the pollutants is done and then is compared with the standards. Further the ground level concentration of the pollutant is obtained using the AERMOD view cloud software which is based on the Gaussian model. A certain site was elected for the study of project. The selected site is a secondary metallurgical industry which does fall under the A category as it is situated in the mandi gobindgarh which is categorized as highly polluted area by CPCB. This project work includes the Collection and interpretation of the Meteorological data ,Collection of Ambient air quality data, Analysis of Ambient air quality data and its interpretation, Evaluation of ground level concentration of pollutants due to stack emission, Analysis of results obtained and its comparison with results from other sources.

## TABLE OF CONTENT

<b>TITLE</b>	<b>PAGE NO.</b>
DECLARATION	ii
ACKNOWLEDGMENTS	iii
ABSTRACT	iv
CONTENTS	v-vi
LIST OF FIGURES	vii
LIST OF TABLES	viii
<b>CHAPTER 1 INTRODUCTION</b>	
1.1 Purpose Of Environmental Impact Assessment Report	1
1.2 History Of EIA	2
1.3 Steps In EIA Process	3
1.4 Screening	3
1.5 Scoping	3
1.6 Baseline Data Collection	4
1.7 Impact Prediction	4
1.8 Mitigation Measures	5
1.9 Public Hearing	5
1.10 Environmental Management Plan	6
<b>CHAPTER 2 LITERATURE REVIEW</b>	8-12
<b>CHAPTER 3 Materials and Methodology</b>	
3.1 Study Period	13
3.2 Selection of Proper Site for Air Monitoring	13-15
3.3 Selection of pollutants to be monitored	15
3.4 Selection of Instrument	16

3.4.1 RDS (Respirable dust sampler)	17
3.4.2 AWS (Automatic Weather Station)	18
3.4.3 FPS (Fine Particulate Sampler)	18
3.4.4 Software Used	19 -20
3.4.4.1 Pavanaarekh v5	19
3.4.4.2 AERMOD Cloud	20
3.5 Calculation Method and Modeling	21- 29
3.5.1 Calculation Method	21
3.5.2 Air Dispersion Modeling	23-29
<b>CHAPTER 4.0 RESULT AND DISCUSSION</b>	<b>30-31</b>
<b>CHAPTER 5.0 CONCLUSION</b>	<b>32</b>
<b>CHAPTER 6.0 REFERENCES</b>	<b>33-34</b>

### LIST OF FIGURES

FIG.NO	TITLE	PAGE NO
1.0	Image of Respirable Dust sampler	17
2.0	Fine particulate sampler	19
3.0	Automatic weather station	19
4.0	Mixing height pattern of fatehgharh sahib district	22
5.0	Image showing the Gaussian plume model	24
5.0	wind rose diagram	26
6.0	Image showing modeling of the stack emission	29
7.0	Bar chart showing PM 10 values for October month	31
8.0	Bar chart showing PM 10 values for November month	32
9.0	Bar chart showing PM 10 values for December month	32
10.0	Bar chart showing PM 2.5 values for October month	33
11.0	Bar chart showing PM 2.5 values for November month	33
12.0	Bar chart showing PM 2.5 values for December month	34

### LIST OF TABLES

TABLE.NO	TITLE	PAGE NO
1.0	Location of different sites	27
2.0	Indian Standard for PM 10 and PM 2.5 (Source CPCB)	30
3.0	Concentration of PM10 and PM2.5 at different sites.	30
4.0	PM values for different months at different locations.	31

# **1. INTRODUCTION**

## **1.1 Purpose of Environmental Impact Assessment Report**

With rapid increase in population, it has become necessary to produce more material for various consumer requirements. This calls for the need for more developmental activities. This comes along the inevitable side effects of development. But the human kind is so dependent on these advancements that it can't stop consuming these facilities, no matter what are its side effects. Hence, the only solution is a keeping the adverse effects minimum, while trying to eliminate them as well, a sustainable collaboration of development with environmental conservation. EIA is one of such useful technique to achieve the aim stated before. It is of extreme benefit to our aim to make sure that the process chosen is not harmful to the environment. For this environmental consequences of the project should be identified and acknowledged at beginning steps. The EIA is having objective to judge in advance the possible undesirable effects on environment that could be caused by the proposed development, and to provide a plan to tackle them in project. It is also beneficiary in avoiding unwanted added costs in future. The EIA withstands for "Environmental impact assessment", this process is used in multi disciplines and is multi iterative process to fortify that environmental thoughts area included in all the resolution about projects that may affect the surroundings. To briefly define the EIA Process aids in accurately define the major harmful effects on environment that the activity can have, and to methods to reduce or to correct the effects.

Monitoring is regarded as pivotal and a segment that is continuous part of the environment impact assessment. Highlights the impacts industry or project can be having upon environment. This phase includes supervising various criteria of the environment like air, water, soil etc. Air monitoring being the most a time consuming of all, needs to be performed twice a week as per the guidelines.

## **1.2History of EIA**

In the National Environmental Policy Act (NEPA) 1969 (**Lynkton(1988)**) of USA EIA was acknowledged as legislation. A sound and strong framework was given for the very first time by any legislation, which was permitting every acknowledged environmental issue to be dealt at the same time. In U.S.A in 1970, after the National Environmental Policy Act (NEPA) Environmental impact assessment was pioneered. It was due to the growing awareness and concerns regarding pollution and other environmental problems.

In India, during looking into the river-valley projects, The Department of Science and Technology which was directed by the Planning Commission of that time, to look with the viewpoint of environment. It was at this time when EIA was introduced in India. It was further stretched for those projects which needed sanction from the Public Investment Board. These were not having enough legislative back up and were administrative decisions. The Environment (Protection) Act on 23<sup>rd</sup> May 1986 (**Muraleedharanet.al(1994)**) was proposed by The Government of India. For the fulfilment of aims of the Act, Environmental impact assessment was decided to be made legal. On 27<sup>th</sup> January 1994 a notification was issued ,subsequent to the law proceedings and amends were made during 4<sup>th</sup> May 1994, after on 10<sup>th</sup> April 1997 , 27<sup>th</sup> January 2000 ,and in 2006.

Nowadays, EIA is adopted by many countries greater than 100 in number as a primary tool for environmental protection and management The main intend of EIA is a tool to make environmental decision-making aware in the early stages of planning by assessment of environmental effects and enacting a layout to lessen the negative factors before the projects starts.

### **1.3 Steps In EIA Process:-**

Following are the steps consisted in EIA process in India -:

1. Screening of the proposed project
2. Assessing the Scope of the project along with alternatives.
3. Collection of baseline data.
4. Predicting the possible impacts.
5. Considering public opinions.
6. Planning the Environment Management.
7. Making the decision.
8. Investigating the clearance conditions

### **1.4 Screening**

The EIA is among the very foremost of project. What could be the result of this project on the environment is the foremost question that arises. Followed by asking, whether or not effect is considerable or not. An EIA may be needed if effects are considerable. This step answering this question is named as screening which can be an important initial step into a formal EIA.

It should be noted that EIA is repetitive method. The area needing formal EIA and related costs are highlighted during the screening. It might call for re-evaluation of whole lay out of the project with intend to mineralizing the pin pointed impacts till the point of no need EIA as per law.

### **1.5 Scoping**

A very vital process required at initial preparation of an EIA is scoping. Here diagnoses of vital issues are done while least significant impacts are omitted. So that only those impacts are considered which does have any significant effect on environment? In this way, EIA studies are targeted on the worthy issues hence saving time and finances from unimportant expenditure.

## **1.6 Baseline Data Collection**

In the step of baseline data collection, for a decided time period accumulation of data concerning meteorological parameters and environment quality is done. So, this awareness with respect to condition of environment is gained prior to the project's beginning. It is then viewed to draw a comparison between the environment conditions prior and later the project's commencement. Temperature, wind speed, wind direction, rain fall etc are the factors consisting the meteorological data. The pollution causing elements as PM10, PM 2.5, sulphur, ozone etc are the elements of air quality.

The data was accumulated from primary as well as secondary sources. It was thereafter weighed against the respective environmental parameters.

## **1.7 Impact Prediction**

Going by its name, this step predicts and estimates the impacts on the environment, caused by the project under consideration. Using the knowledge available The impacts of project on environment (air, soil, water) are assessed. For example the possible processes which could happen during construction and production or running phase. Estimation of pollutants and their quantity, suspected to generate. For this step, mathematical modeling and software are taken of help.

Prediction of the impact is carried out by analyzing the present existing conditions and knowledge of former, current and future predicted conditions. All the impacts which may directly or indirectly and even their sum total impact predictions need to be assessed, and the result can be could be advantageous or can be harmful, its effect may be for short time or long time , it can be reversible or irreversible, and it can changes with time or may be for long time. There are many available methods to do it and they vary according to components. However, impact prediction most of the time is poorly addressed, and can bereckoned as the most complex part of EIA. Impacts which are direct are generally swift to determine, on the other hand indirect and total impacts are more difficult to determine.

## **1.8 Mitigation Measures**

The objective of mitigation is to find out protecting alternatives, corrective steps protecting the nature surrounding and the area which is affected by the project. It is a creative as well as practical level of the EIA process. It targets at searching most suitable ways of evading, curtailing and correcting impacts. In order to be of significant use, mitigation measures needed to be brought into action in accurate way and at the exact time. This process is termed as impact management occurs while the project implementation. A written plan is must for this, consisting a plan of approved measures. Its need and Prospectus will be there during the whole duration of project time and again.

Expert Judgment

- Specialists are involved in predicting impacts based on their experiences
- Sound judgment from expert will later be evaluated by EIA review team
- Expert judgment or Professional Judgment is considered a ‘best’ estimate

## **1.9 Public Hearing**

Public which has comes under the field of effect of the project should have some say regarding the project. So their opinions need to be given due thought as they will be the one facing direct effect of project on environment on their area.

## **1.10 Environment Management Plan**

An organized plan as specified legally in an EIA report is called Environment management plan. It is formatted so that it is able to assist during the process of execution of Environmental Protection Measures In practice.

For the purpose of carrying out this plan impact mitigation, monitoring and auditing of environmental parameters are planned distinctively. For the formulation, execution and

monitoring of the environmental protection measures EMP Is needed, throughout and after the commissioning of the project. Another part of EMP is to formulating the Environment management team. This team works in the company to supervise and handle the environmental issues that are faced in the project's construction and production or running stages.

Government Bodies dealing with the EIA process are:-

1. MOEF&CC- stands for Ministry of Environment, Forest and Climate change
2. SEIAA, stands for State Level Environment Impact Assessment Authority
3. EAC stands for Expert Appraisal Committee
4. SEAC stands for State Level Environment Appraisal Committee
5. SPCB stands for State Pollution Control Board

The Central Govt. shall constitute SEIAA as per the Environment(Protection) Act 1986.

The state level environmental impact assessment authority designates a three member committee, which comprises sole Chairman and a Member-Secretary. It must be ensured that the member secretary is a active state government officer, and they must have knowledge of Laws related to Environment. While rest of the remaining couple members must be experienced or specialist, among the two one of them is specified to be a specialist of the process related to Environment Impact Assessment, and can be the Chairman of the State Environmental Impact assessment Authority.

We can categorize all the projects and activities into two segments.

1. Category A and,
2. Category B

The categorization is done on the basis of their impacts on human health and natural and manmade resources.

This classification of project is done along the line of the basis of its results and effects on the Environment of the area. The estimation of the project's spatial impact is done by assessing the parameters like the needed area for project, annual production etc.

As per the commendation of an Expert Appraisal Committee (EAC), Central Government, An environmental clearance from the Central Government in the Ministry of Environment and Forests (MoEF) is needed in the advance for those projects or activities which are marked under class 'A' in the Notification ,along with the modernization and expansion of projects on hand or activities and variation in contents of the projects.

For the projects which come under Category 'B', consisting the modernization and expansion of the current projects or changes in contents of the product mix will need environmental clearance beforehand from the State or Union territory Environment Impact Assessment Authority (SEIAA). The decisions of SEIAA shall be grounded on the guidelines of a State level expert appraisal committee as stated in this notification. In the case of non presence of a duly constituted SEIAA or SEAC, projects or activity classified under the Category 'B' will need to be considered as the Category A, if it is either situated entirely or in elements falling within the boundary of 10 km of:

- (i) Area Protected under the Notification under Wild Life (Protection) Act, 1972,
- (ii) Inter-State boundaries and international boundaries.
- (iii) Area which are Eco-sensitive .
- (iv) Areas which are Critically Polluted areas as stated by the Central Pollution Control Board from time to time.

Despite of the fact that the industry's production is not adequate to keep it in the category A project still it is termed as 'A' given to its location being under critically polluted area.

## 2.0 REVIEW OF LITRATURE

According to **Therivel and Morris (2001)** EIA has various phases and procedures. air pollution is going to be examined in this work, which is elementary to EIA, the probable impacts that the project can have, need to be thought about during each phase of the process and for the major components of environment. Guessing the impacts of a growth it is important to take the note of the changes in the baseline conditions that can happen many after many years of the project. Baseline monitoring is done during the prior to the project of the measurement of environmental parameters; it is done to know the variants of the of the environment and selecting reference points with respect to which variations can be calculated. The measurement of environmental parameters done during the project construction and implementation to identify variations in the environment around the project is known as Effects monitoring. While the measurement of environmental parameters which is done after regular intervals continuously to make it sure that that process is as par to the regulations and standards is known as Compliance monitoring

This is mostly done by analyzing the present baseline conditions, and knowledge of past, present and predicted conditions. Different types of impacts predictions should be done , and they could be good as well as bad, short or medium, long term, and they can pose permanent damage or temporary damage . There are several methods to analyze and they vary between EIA and its components. However, prediction of impact is often poorly addressed.

According to **Wathern, P.(1998)**.Uncertainty poses a major problem in prediction of impact. As, stated, uncertainties decides how an effect can be described, and hence tells us about the significance of a impact. The amount of information and its accuracy includes acceptable levels of impacts and the predictions can be compared against that impacts, the importance of an impacts over other impacts, comparing the predicted effects with each other and choosing the best suitable method for impact prediction are some of the main problems faced during impact prediction of a project.

Continuous sampling and time averaged sampling are two main type of sampling techniques. Continuous sampling is carried out by automatic samplers, optical , spectroscopic methods or electrochemical, and which produces continuous records of concentration values. The particular

time – averaged concentration data can then be obtained from continuous records..after that Samples are analyzed by established methods (physical, chemical, and biological) for the concentration values which are the effective average over the period of sampling. These time averaged values can also be obtained by sampling the known volume of the air for a set time.

According to **Glasson and Chadwick .A. (2005)** Prediction of the impacts over the life of a project including different stages like construction and operational and the change of these impacts over the time period must also be taken into account..

According to **Kimbrough et.al (2008)** Maximizing a positive impact might be the inclusion of meteorology (that is, wind speed and wind direction) as a criterion. One would not want to select a location in which the air pollutant emissions would not be “blowing” toward the monitoring instruments

According to **B.Sivertsen (2004)** to know the information about the value of these different contributions it is very necessary to locate monitoring stations so that represents the different types of impacts. Different sites represent different types of data for ex. A site selected near roads may represent the pollution due to vehicles while some other site may represent the background data. Due to these representations of the site we may need More than one monitoring site in order to characterize the air quality. Along with the air pollution data, we generally need meteorological data to identify and quantify the sources which are contributing to the values.

The main parameters in the movement of the contaminants in the atmosphere is the wind speed and its direction, which further are affected by the vertical and horizontal temperature gradients, both at the regional and local level. It can be said that, the more the wind speed, more will be the turbulence and the more rapid and complete is the dispersion of the pollutants in the air.

During the measurement of air quality or analyzing the results from sampling it is important to keep in mind that the data we are viewing are the sum of impacts or contributions originating from different sources on different scales.

- The concentration due to Natural background concentration.
- Concentration due to Regional background.
- Average city background concentration (kilometer scale impact),
- Impact due to traffic along local streets and roads,
- Impacts due to small area sources like open air burning (waste and cooking),
- Impacts due to large point sources such as Industrial emissions and power plants.

According to **S.Larsen et al. (1999)**<sup>[8]</sup> The number of sites generally depends upon the size of the area and its topographical variations like, mountains, valleys, buildings etc, the variety in pollutants from source and upon some other monitoring objectives such as,

1. The kind of equipment should be used
2. Number of the sampling stations needed.
3. The sampling time and its frequency.
4. Spatial density of sampling stations.
5. Number of samples that are needed and its period.
6. The locations of the sample.
7. the knowledge of the additional background information , like Meteorology, population density, emission sources and their emission rates, their effects and impacts.

According to **Caldwell and Angus (2001)** among all the EIA follow-up activities, Monitoring is the most continuous activity. It is essential to obtain the data for the other activities and allows project and environmental performance objectives to be attained. Monitoring is a repetitive processes, a program of repetitive observation, measurement and recording of environmental parameters and operational parameters over a period of time.

In Mandi Gobindgarh, the levels of the particulate matter increases during the arrival of winter and reached a maximum in the months of Nov.–Dec and the levels again started declining with the onset of summer. The major reason for the increase in levels of particulate matter in winter can be the fact that in this region, the meteorological conditions in winter season are mostly stable. These type of conditions results in thermal inversions and leads to the lesser dispersion and increase in the concentration of the pollutants.

It is a well known fact that that from cardio respiratory health aspect the PM<sub>2.5</sub> plays a greater role than the PM<sub>10</sub>. Most of the time the sources of PM<sub>2.5</sub> are anthropogenic whereas the source of PM<sub>10</sub> is normally natural.

According to **Cichowicz R & Fetter W (2017)**The higher values of air pollution in different months of a year occurs due to difference in climate during different months or seasons, and accordingly with different atmospheric conditions in particular months, change in state of weather on a given day.

According to **K Elminir and Hamdy (2005)**.Air pollutant concentrations are not only affected by the sources of emission but also by meteorological variables Meteorological variables play an important role in the dispersion, transport, photochemical reactions and secondary pollutants formation Meteorology plays a important role in determining the concentrations of the pollutants. Meteorology effects the dispersion of the pollutants into the atmosphere. Once the pollutants come into atmosphere their fate is decided by the local meteorological conditions. Many of the air pollution episodes are understood to have occurred under adverse meteorological conditions.

According to **Nautiyal et al. (2007)**.It is well established that from cardio respiratory health aspect the PM<sub>2.5</sub> plays much more significant role than the PM<sub>10</sub>. Also the sources of PM<sub>2.5</sub> are anthropogenic whereas the source of PM<sub>10</sub> is normally natural.

According to **K.Elminir&Hamdy (2005)** the variation of the pollutants with time in ambient air should also be taken into account. Change in meteorological conditions during monitoring should also be considered, as these conditions change with time. After the wind the variation of temperature with height plays a very important role in air pollution. The increase of temperature with height near the surface is known as inversion and is a point of concern because these

inversion, depending upon the level at which it occurs with respect to the stack can pose a problem and does not allow the dispersion to take place which results in very high ground level concentrations.

According to **William t. White (1982)** During the selection of site it is helpful to assign suitability values<sup>[13]</sup> to site and then on the basis of values narrow down the selected sites. Normally, the value of the scale ranges from "very good suitability" to "very poor suitability" The rating can be done on the basis of

1. Population density around selected site.
2. Sensitivity of the location (ecologically sensitive, noise sensitive, hospital etc.)
3. Aesthetically important sites (monuments, religious sites)
4. Its location for. ex the site selected for obtaining regional background data, upwind and Downwind.

According to the **Guidance manual for EIA of Metallurgical industry**.The selected sites needs to provide the right location for getting pollutant concentration for:-

1. Agricultural site
2. Residential area
3. Inside industry
4. Near road
5. Upwind
6. downwind
7. crosswind

There are also methods for impact prediction process the most widely used method in India is Expert Judgment method , in this method

- Specialists are involved in predicting impacts based on their experiences
- Sound judgment from expert will later be evaluated by EIA review team
- Expert judgment or Professional Judgment is considered a 'best' estimate

## **3.0 Material and Methodology**

### **3.1 Study Period**

First of all study period was selected according to the Guidelines. The Environmental Monitoring for the EIA study, for the proposed Steel Manufacturing plant, is conducted for the post monsoon season. Primarily an investigation survey of the study area was carried out and then the field monitoring to determine meteorological parameters, ambient air quality, quality of water (surface and Ground), soil quality and noise quality was done in the duration beginning on 1<sup>st</sup> October 2017, till 31<sup>st</sup> December 2017. Additionally, some aspects as land area, Socio economic status, meteorological conditions from past etc. have been scrutinized according secondary information obtained from the sources like, district gazetteers, data from Indian meteorological department, district census reports etc.

### **3.2 Selection of Proper Site for Air Monitoring**

Selection of site for air monitoring is very important because it helps us to reduce the numbers of sampling location for a reliable data.

For ambient air monitoring the number and locations of sampling stations depends on the given parameters:-

1. Presence of Ecological and other sensitive area.
2. Topography of the area.
3. Population and its distribution inside the area to be monitored.
4. Total area to be monitored.

For this Study, all the sampling sites are spotted with aid of Google maps and site visits. The ambient air quality monitoring was done to get the quality of ambient air for single season. Monitoring was carried out in post monsoon season (October 2017 to December 2017).

Places where the Concentration of pollutants varies frequently from place to place more number of monitoring stations are needed. Topographical features like Mountains, hills, water bodies also affect dispersion of pollutants into the atmosphere.

The previous information obtained on the ambient air quality of allocation can help in basis for selection of the sites where monitoring needs to be conducted, Previous studies helps to estimate the nature and extent of the problem. Previous studies which consist of data obtained for any health studies etc.

Number of sampling sites is also a important aspect of the monitoring, The no. of sampling sites depends on different factors like:-

- a) Total area to be monitored.
- b) The variation in the Concentration of the pollutant over the covered area.
- c) Different pollutants which needs to be monitored at that area.
- d) Types of Pollutants to be monitored.
- e) Data like Population figures which can be helpful to know the likely air quality deterioration as also health implications.

There are some guidelines given by CPCB for selection of the sampling location.

1. The site needs to be away from absorbing surfaces such as absorbing building material. The distance depends on several parameters like type of absorbing surface, nature of pollutant etc. but it should be at least 1m away.
2. Sampled site needs to be away from major pollution sources. The station should be at Least at a distance of 25 m away from domestic chimneys, especially if the height of the Chimney is less than the sampling point, with larger sources the distance should be greater.
3. Inlet height needs to be about 3 – 10 m above from the level of the ground.

4. The instrument should be placed to allow the free flow of the air without any disturbance to the instrument. The instrument should be placed away from Corners, balcony or narrow spaces
5. The air sampler must placed at a distance of two times from height of nearby obstruction like Buildings, trees etc.
6. The instrument must be paced more than 20 m away from any nearby trees.

The method through which the analyst combines laws, standards, and problems during the study of the project is the key to the site selection study use during environmental impact assessment. Analysts create Most analysts create scales of suitability or acceptability for each issue, and it is in these scales that the laws and standards are incorporated.

Normally, the values of the scale range from "very good suitability" to "very poor suitability"  
The rating can be done on the basis of

1. Population density around selected site.
2. Sensitivity of the location (ecologically sensitive, noise sensitive, hospital etc.)
3. Aesthetically important sites (monuments, religious sites)
4. Its location for. ex the site selected for obtaining regional background data, upwind and Downwind

The sites are selected while keeping in mind

1. Public concerns (like Residential or agricultural fields)
2. Scientific judgment (like upwind, downwind)
3. Commercial or economic importance (like near monuments)

### **3.3 Selection of pollutants to be monitored**

The pollutants selected are based on the TOR (Terms of reference issued) by the Expert Appraisal Committee. PM<sub>10</sub>, PM<sub>2.5</sub>, SO<sub>2</sub>, NO<sub>x</sub>, CO are the main pollutants coming from secondary steel industry and their monitoring is mentioned in the TOR. So for the given project work sampling of PM<sub>10</sub> and PM<sub>2.5</sub> is selected.

### **3.4 Selection of Instrument**

Selection of the instrument depends on the factors like pollutants to be monitored, time of sampling, location selected and availability etc.

On the basis of these parameters instruments selected are given below:-

#### **3.4.1 RDS (*Respirable dust sampler*)**

Respirable dust sampler is used to measure the value of PM<sub>10</sub> and gaseous pollutants. The gaseous pollutants are measured by passing the surrounding air through the impinger bottles containing suitable solutions to dissolve the required pollutant then the solution is further tested in laboratory to know the concentration of pollutants through chemical and physical testings.

Cyclone separator dimensions and inlet velocity are specially designed to selectively separate out the particles above the size of 10 µm. The particles bigger than 10 micrometers are then collected on the filter paper.

Particles which have the diameter lesser than the cut-point diameter are deposited on the filter paper. The mass of the collected particles is determined by knowing the difference in the weights of filter paper before and after the sampling is over.



**Figure 1. Image of Respirable Dust sampler**

Respirable dust sampler used for sampling works on the principle of separation of particles of different sizes on the basis of their weight difference when passed through a cyclone separator at a particular speed get separated due to centrifugal force. Cyclone separator dimensions and inlet velocity are specially designed to selectively separate out the particles above the size of 10  $\mu\text{m}$ . The particles bigger than 10 micrometers are then deposited on the filter paper. The RDS must be placed at a proper height above the ground to get proper concentration without the effect of the dust on the ground.

The filter paper used is of whatman with dimensions of 20.3 X 25.4 cm (8 X 10 in) and the air is passed through filter paper with a rate of flow of about 1132 L/min. Particles having the aerodynamic diameter lesser than the cut-point of the inlet are deposited on the filter paper. The mass of the particles is obtained is through the difference in filter paper weights before and after

the sampling. The concentration of PM<sub>10</sub> in the designated size range is obtained by dividing obtained weight difference with the total air volume sampled.

### **3.4.2 AWS (*Automatic Weather Station*)**

Automatic weather station is used to obtain the Meteorological data like temperature, humidity, rainfall, wind speed and direction etc. these all parameters are used to know the local weather conditions. Knowledge of Local weather conditions are necessary to require as they help us to predict the movement of pollutants in the atmosphere. The weather data was obtained from the automatic weather station situated at the lab.

### **3.4.3 FPS (*Fine Particulate Sampler*)**

Fine particulate sampler is used to measure PM 2.5. it is based on the WINS impact method. particles below the size of 2.5um Gets collected on the filter paper and then the difference in their weights gives the concentration of the particulate matter. The flow rate for FPS is set at 1 m<sup>3</sup> per Hour. The flow velocity and dimensions of impactor are specially designed to separate out the particles bigger than 2.5 um.

Ambient Air comes in the sampler through an Omni-directional; it is specifically made to give a clear aerodynamic cut-point to the particles of size greater than 10 microns. After that, the air stream goes in a WINS Impactor, which maintains the fraction between PM<sub>10</sub> and PM 2.5. The PM<sub>10</sub> and PM 2.5 impactors employed in the sampler are designed on the standards in accord to the USEPA and in a way that the system meet the terms of the international norms for PM 2.5 Samplers. The rate of sampling rate is kept constant at 1 m<sup>3</sup>/hr by a critical orifice.



**Figure 2.0 Fine Particulate Sampler**

### **3.4.4 Software Used**

#### **3.4.4.1 *Pavanaarekh v5***

It is a application used to analyze and plot wind data into graphical form .wind speed, time and other data like its direction are put into software and the wind rose diagram is generated . in this for a great amount of data can be shown in a single figure . The number of arms can be selected by the user from the software The length of the wind rose arm shows the frequency of the particular wind direction and its position on polar co-ordinates represent wind direction.. The data for this project is first downloaded from AWS and then if converted to exel file and in required format for use in software. In this software wind rose can be saved in different format and can further be used in other software.

#### **3.4.4.2 AERMOD Cloud**

AERMOD Cloud is an air dispersion modeling software .this application incorporates popular models AERMOD and ISCST3 into one integrated Graphical User Interface(GUI). AERMOD and ISCST3 models are used extensively for Environmental Impact Assessment (EIA) studies to asses air pollution concentration. Both are based on Gaussian model. This model can be used for both stationary as well as for mobile sources of emissions. In this model, the dispersion in the three dimensions is calculated. This model is a simple mathematical model which is used to know the concentration of pollutants at some location located at some distance from the source of emission.

The following precautions are followed in sampling of air pollutants:-

- a) Corrective and preventive maintenance of the finite particulate sampler and respirable dust sampler must be done.
- b) The dust sampler must be properly calibrated to get the correct flow rate.
- c) The filter used for the sampling must be of good of quality.
- d) Weighing balance must be used for weight of filter paper and silica gel bottle must be kept in Weighing chamber to absorb moisture and to avoid any error during weighing.
- e) Filter paper must be weighed after conditioning it in the desiccators containing moisture absorbent
- f) Filter should be properly mounted over the top of the screen with the rough side of the filter Paper facing upwards. .
- g) Manometer must be filled properly and changed to maintain zero level
- h) Sampling tray with ice must be used to avoid evaporation loss and better absorption.
- i) Distilled water must be added to compensate for evaporation loses
- j) The obtained samples must be preserved properly after the sampling. Obtained Gaseous samples in impengers must be preserved properly in an ice box or refrigerator (below 5 ° C) prior to analysis

### 3.5 Calculation Method and Modeling

#### 3.5.1 Calculation Method

Calculation method used know the concentration of the particulate matter is shown

Calculation of Volume of Air passed through sampler  $V = QT$

T = Total sampling time in minutes

V = Volume of air sampled in cubic meters

Q = Average flow rate in cubic meters /minute

Calculation for PM10 present in Ambient Air

$$\text{PM10} = \frac{(W_f - W_i) \times 10^6}{V}$$

Where :

PM10 = Mass concentration of particulate matter less than 10 micron diameter in  $\mu\text{g}/\text{m}^3$

V = Total Volume of air sampled in cubic meters

$W_i$  = Initial weight of filter paper in grams.

$W_f$  = Final weight of filter paper in grams.

$10^6$  = for converting g into  $\mu\text{g}$ .

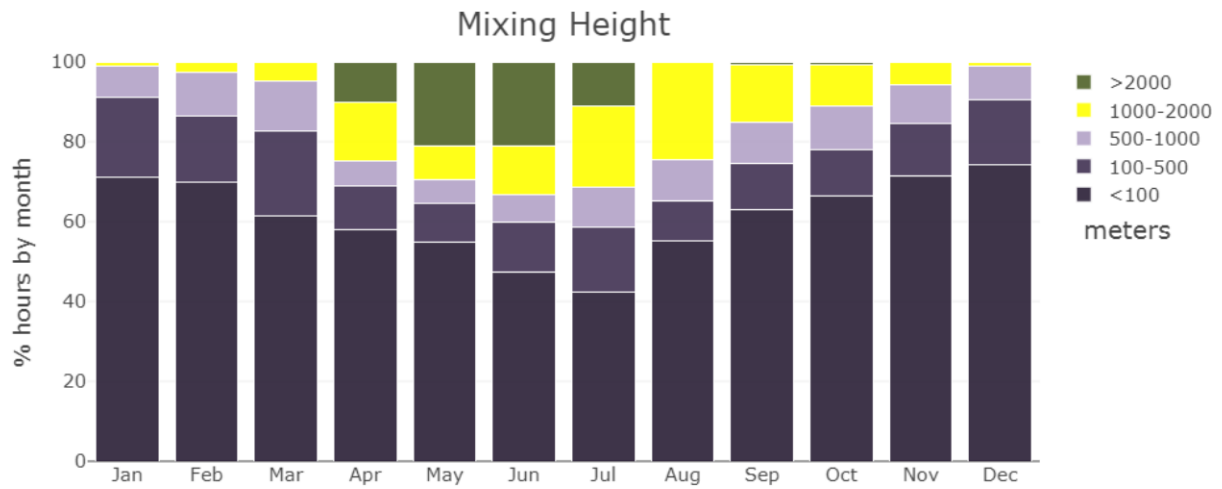

**Figure 4.0 Mixing height pattern of Fatehgarh sahib district**

The mixing height represents the extent of mixing of air in the vertical direction and suspended particles above the ground level. The determination of the height is done by the observing the temperature profile of the atmosphere. A portion of the air which arises from the surface of the Earth will rise at a given rate (called the dry-adiabatic lapse rate). For the time, the parcel of air is warmer than the surrounding air temperature; the parcel will continue to rise. However, when its temperature decreases and it becomes colder than the surrounding temperature of the environment, its movement slows down and finally it will stop. At that point the temperature of the parcel crosses the curve showing the vertical environmental temperature profile determines the mixing height.

As it is clear from the graph that post monsoon season the time percentage of mixing height starts to decrease and during winter most of the time it remains less than 100 meters from ground.

So after monsoon the dispersion of pollutants become less and it starts to further decrease during winter and can become worse

### **3.5.2 Air Dispersion Modelling**

Air pollution modeling is a mathematical tool which describes the causal relationships between meteorology, emission, atmospheric concentrations and other factors. Air pollution measurements give important, numerical information about the ambient air pollutant concentrations and its deposition.

The total concentration of a pollutant consists of those from local emission sources such as, chimney-stacks, roads, homes, industry etc., and those that are transported from other areas by the winds from further away. If we remove all the local sources, the remaining portion represents that which comes in from further away and it is this portion that is called 'background'.

In most of the situations background contribution can represent a major and dominant part of the total concentration of the pollutant, so it is important to give this careful consideration. A good knowledge of the background concentrations is important during assessment of the air quality as it gives us a good understanding of local pollutant sources.

Air dispersion modeling for the stack of induction furnaces was done by using AERMOD cloud 5 online. AERMOD Cloud is an air dispersion modeling software .this application incorporates popular models AERMOD and ISCST3 into one integrated Graphical User Interface(GUI). AERMOD and ISCST3 models are used extensively for Environmental Impact Assessment (EIA) studies to asses air pollution concentration. Both are based on Gaussian model.

This model is a simple mathematical model which is used for the estimation of the concentration of pollutants at some point which is at a distance from the pollution emitting source. The Gaussian model can work both for stationary and also with the mobile sources of emissions. In the Gaussian model, the dispersion of the pollutant in the three dimensions is calculated. The Air pollution is showed by an idealized plume coming from the top of a stack having some height and diameter. The major assumption in this model is that over short periods of time like few hours, the conditions are assumed to be steady with respect to the air emission of the air pollution and meteorological changes.

The main limitation of the Gaussian model is that this model is not suitable for pollutants which undergo chemical transformations in the atmosphere. Also, that this model depends largely on the steady state meteorological conditions and is short term in nature.

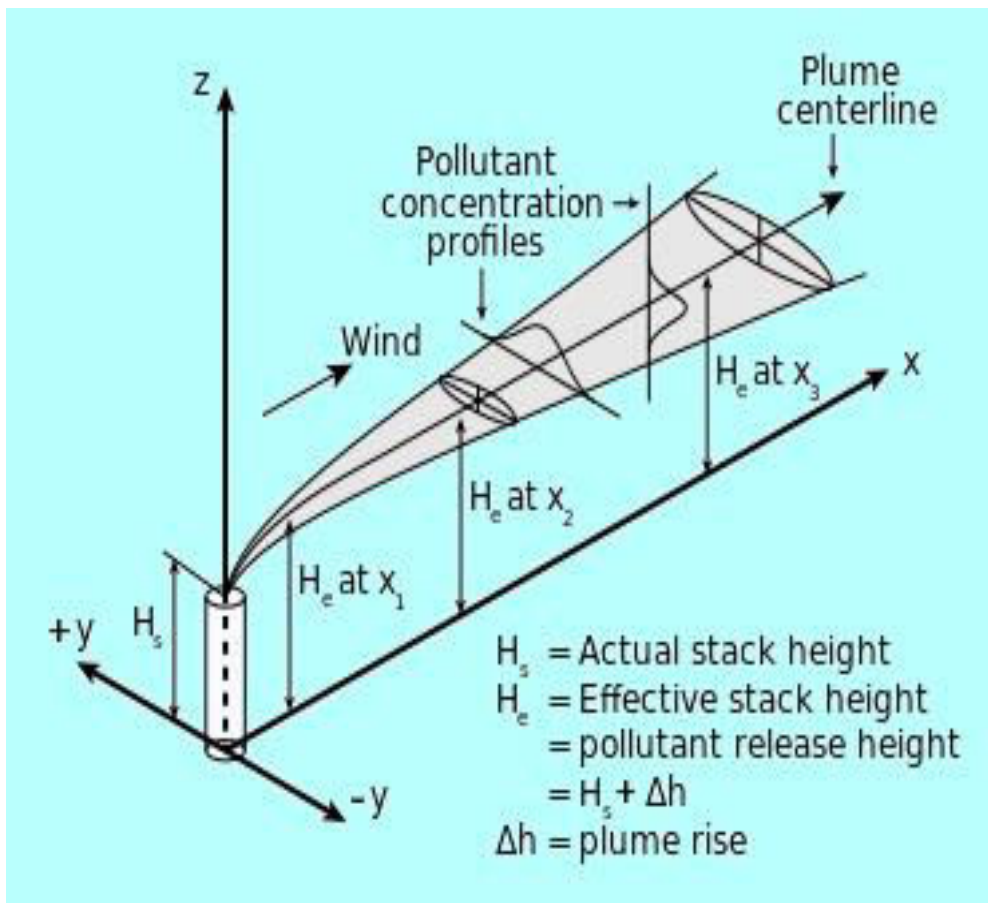

Figure 4.0:-Image showing the Gaussian plume model

The concentration of the air pollutant depends on different and number of variables, like the distance of the receptor from the pollution emitting source, emission rate and the condition of the atmosphere at that time. The important atmospheric conditions needs to be considered are wind direction, its speed, and the variation of temperature with change in height of atmosphere at that location. If with the increase in height the temperature of the atmosphere decreases with the rate higher than the adiabatic lapse rate, then the atmosphere is considered to be in unstable equilibrium and its upward motion increases. This is to keep pollution concentrations moderate or lower near the ground level. But, in contrast if with the increase in height the temperature of the atmosphere decreases at lower rate than the adiabatic lapse rate or increases with height the upward movement is reduced or damped. This will results into higher pollution concentrations.

The Lateral dispersion of the pollutants will depend on the parameter known as the atmospheric condition, which tells us the relative stability of the surrounding air, while the Dispersion of the pollutants in the direction of cross-wind and in the vertical direction will be governed by the Gaussian plume equations. An assumption is made in the Gaussian model that the dispersion of pollutants in these two given dimensions i.e. Lateral and vertical direction will take the form of a normal Gaussian curve, with the maximum concentration reaches at the centre of the plume.

The Gaussian model is used to calculate the coefficient for horizontal and Vertical Dispersion and concentrations at ground level or to calculate the Effective Stack Height, The Gaussian plume have the capability to calculate the concentration of pollutants at any point in space, it is done by using the equation as stated below:

$$C(x, y, z) = \frac{Q}{2 * \pi * u * \sigma_y * \sigma_z} * \exp\left(\frac{-y^2}{2 * \sigma_y^2}\right) * \left(\exp\left(\frac{-(z - h)^2}{2 * \sigma_z^2}\right) + \exp\left(\frac{-(z + h)^2}{2 * \sigma_z^2}\right)\right)$$

Where,

C = Concentration of the emission (micrograms/cubic meter) at any point meters downwind of  
The source.

Q = quantity or mass of the emission (in grams) per unit of time (seconds)

u= speed of the wind (in meters per second)

h = height of the source from the ground level (in meters)

During the dispersion modeling using Gaussian plume model the pollution concentration towards downwind of a source is considered to be spreading outward from the centerline of the plume in the form of a normal statistical distribution and its spread is in both the horizontal as well as in the vertical directions.

During the analyzation of the Gaussian plume model, the assumption made is stated below.

- 1) The emission is Continuous and diffusion is negligible in the direction of travel.
- 2) Material which is diffused is assumed to be a stable gas or aerosol.
- 3) Background pollution is considered to be negligible.
- 4) The conditions are Steady-state.
- 5) There is no change in speed and direction of the wind with change in time and elevation.
- 6) Wind shear has negligible effect on the of wind shear on the horizontal diffusion.
- 7) The parameters representing the dispersion is assumed to be a functions of  $x$  (and hence  $u$  alone).
- 8) The topography is assumed to be flat and open country.

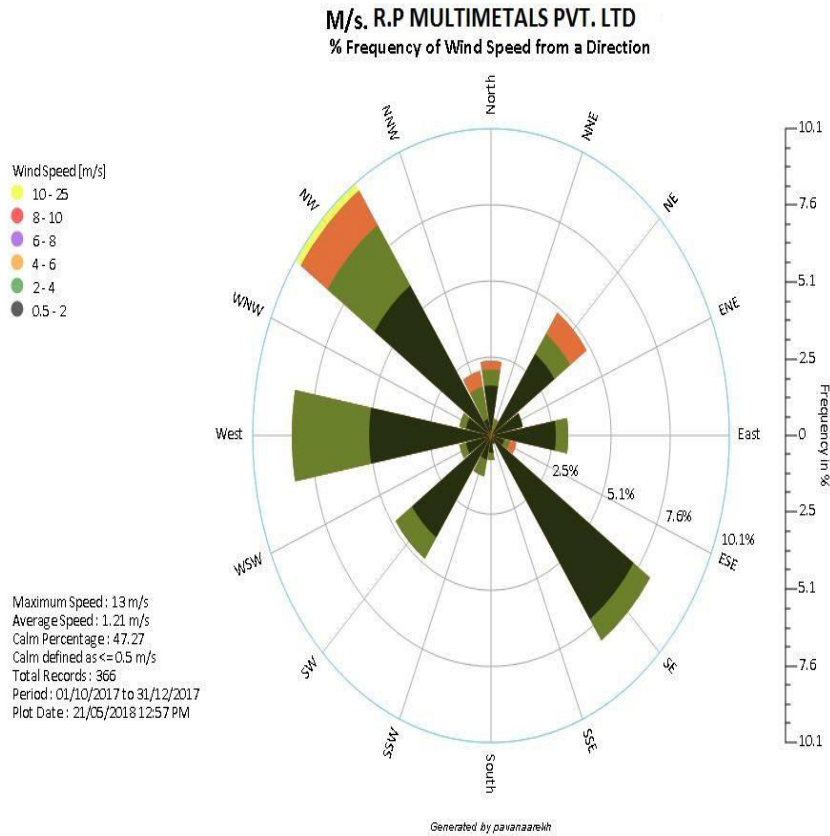

**Figure 5.0:-wind rose diagram**

Wind rose from the wind speed and direction data of post monsoon months is plotted here, the wind vector is flowing from type. So it is clear from the diagram that during this period the wind flows from northwest side predominantly.

On the basis of the wind rose diagram and other requirements following sites are selected and reason of selection is given below:-

**Table 1.0:- Selected air monitoring locations**

Selected Site	Reason of selection
Project Site	The project site gives the amount of pollutants inside the industry
BaraungaZir	This village is located in downstream direction of the industry and sampler is placed near agricultural fields.
Amloh	The sampler here is placed in residential area so the site represents pollution in residential area.
Ambemajra	This village is alongside the main highway, so this site includes PM due to traffic also.

These sites fulfill most of the requirements for monitoring sites, the instrument was set near agricultural area in baraunga zir village and baraunga zir village is located at downstream of the industry, so this location gives us the concentration of pollutants at downstream as well as near agricultural area. Second location Amloh represents the populated area, the sampler here is placed in residential area. Third site Ambemajra is located near the main highway so it shows us the pollution near the highway.

## 4.0 RESULT AND DISCUSSION

With the help of wind rose diagram and other meteorological data the air modeling of the stack emission is done using the AERMOD view cloud software.

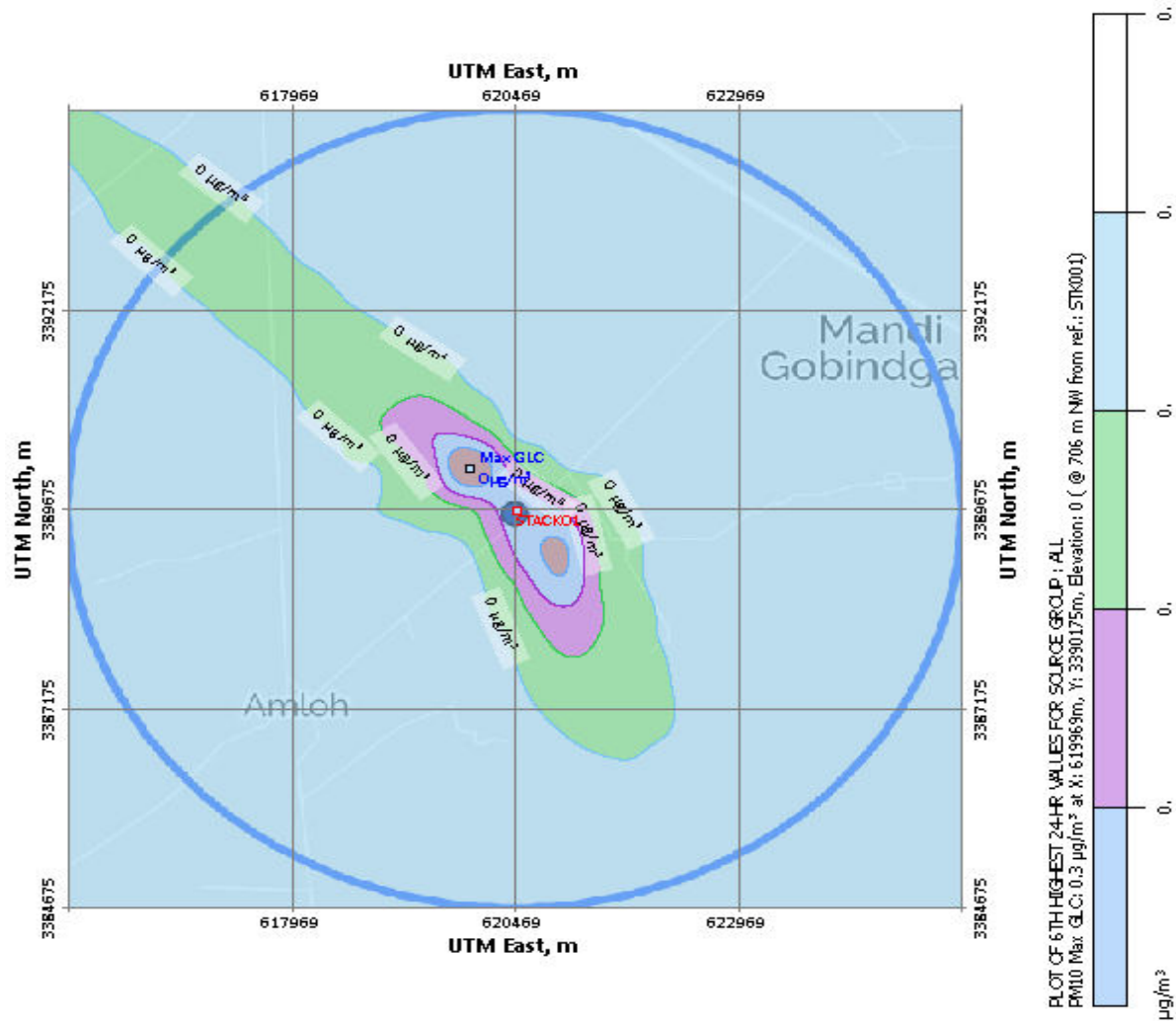

**Figure 6.0 image showing modeling of the stack emission**

The dimensions and data used to get GLC.

Stack Dia = 0.75 m

V= 12.89 m/s

Temp = 388 K

PM Conc = 50 mg/Nm<sup>3</sup>

**AERMOD RUN SUMMARY REPORT**

AN AERMOD PROEJECT  
Dasmesh Casting Pvt. Ltd.

Predicted Ambient Concentrations of PM10 [SIXTH Highest]] Group: ALL

Avg. Period	RANK	Conc., µg/m³	X, m	Y, m	ZELEV, m	Direction #	Distance, m #
24-HR	6TH	0.31	619968.75	3390175.45	0.00	NW [315°]	707.00

The GLC modeling shows that the max GLC value reaches to 0.3ug/m<sup>3</sup> the flow of pollutant is predominantly towards the North East side as shown in the figure.

**Table 2.0 Indian Standard for PM 10 and PM 2.5 (Source CPCB)**

S.NO	Air Quality Parameter	24 HRS (µm)	Annual (µm)
1	Particulate matter (Size less than 10 um)	100	60
2	Particulate matter (Size less than 2.5 um)	60	40

The sampling is done at these four places twice in study period the results obtained are presented in the tabular form.

**Table 3.0 Concentration of PM10 and PM2.5 at different sites. Values of Particulate Matters for different months**

S.NO	Location	PM10	PM2.5
1.	Project Site	85.0--108.2	37.4-45.0
2.	BaraungaZir	85.2-96.3	30.1-36.6
3.	Amloh	80.5-92.8	32.1-40.5
4.	AmbeMajra	85.8-96.4	28.4-36 .3

The following table shows the value of PM 10 and PM 2.5 at four different locations for three different months October, November and December. The pre-monsoon months are selected to avoid effect of rainy season.

**Table 4.0:- PM values for different months at different locations.**

S.NO	MONTH	LOCATIONS							
		Project Site		Barunga Zir		Amlloh		Ambe-Majra	
		PM 10 ( $\mu\text{m}$ )	PM 2.5 ( $\mu\text{m}$ )	PM10 ( $\mu\text{m}$ )	PM 2.5 ( $\mu\text{m}$ )	PM 10 ( $\mu\text{m}$ )	PM 2.5 ( $\mu\text{m}$ )	PM 10 ( $\mu\text{m}$ )	PM 2.5 ( $\mu\text{m}$ )
1.	October	85.1	37.4	85.2	36.6	80.5	33.7	85.8	28.4
2.	November	108.2	41.3	96.3	34.1	92.8	32.1	96.4	33.1
3.	December	87.4	45.1	95.6	36.6	88.2	40.5	93.1	36.3
AVERAGE		93.56	41.26	92.36	35.76	86.4	36.2	91.2	32.7

As it is clear from the values that the amount of particulate matters increases from October to November and the reason is clear that during winters the dispersion of the pollutants into upper atmosphere decreases and also they get trapped due to fog and mist. The values at different locations are different due to their proximity from the industrial area and from main highway. The values of PM 10 and PM 2.5 are maximum inside the industrial premises due to industrial processes which emits dust and other pollutants.

Comparison of PM 10 values at different locations are shown in the graphical form for different months.

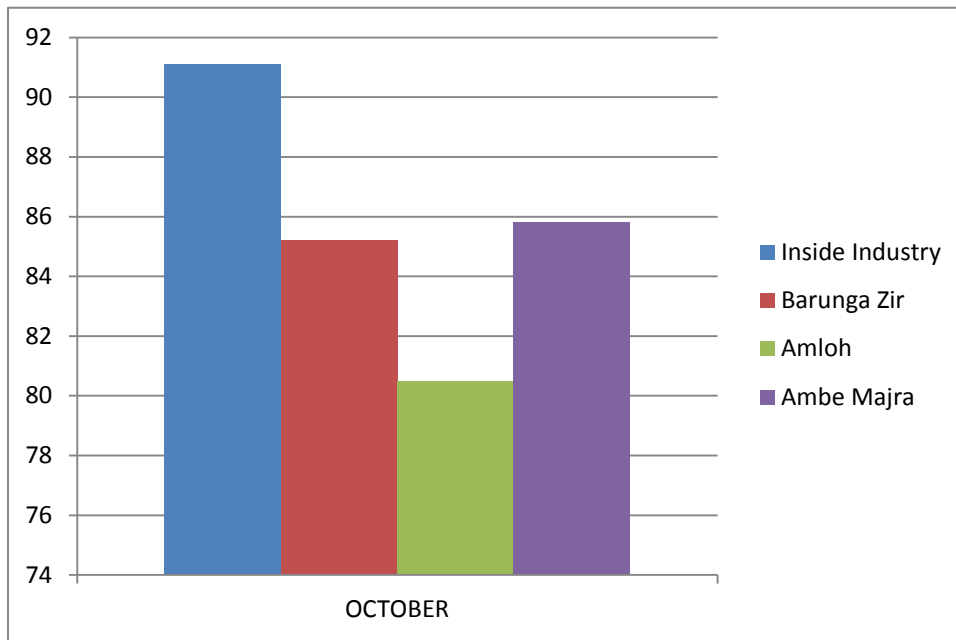

**Figure 7.0:- value of PM 10 for month of October**

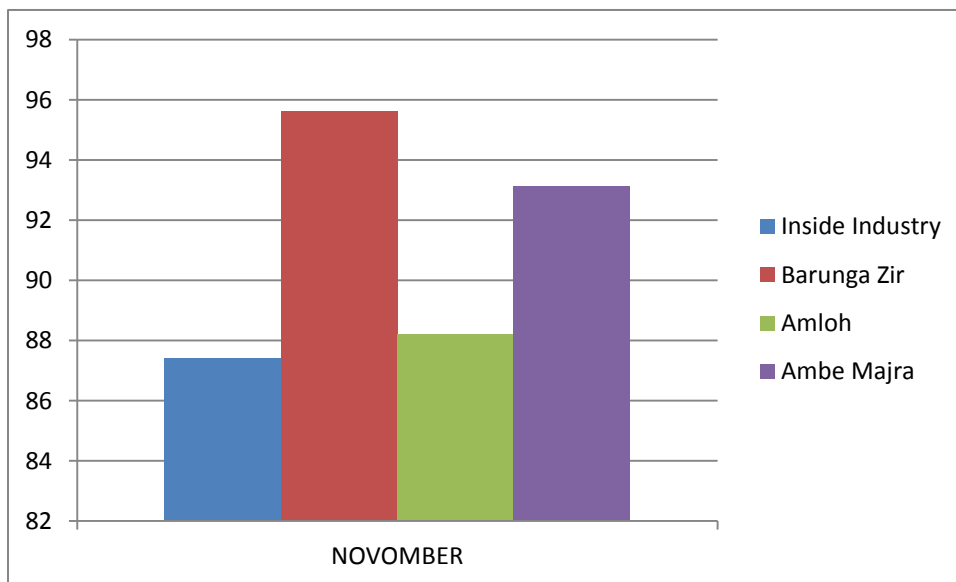

**Figure- 8.0 :- Value of PM 10 for the month of November**

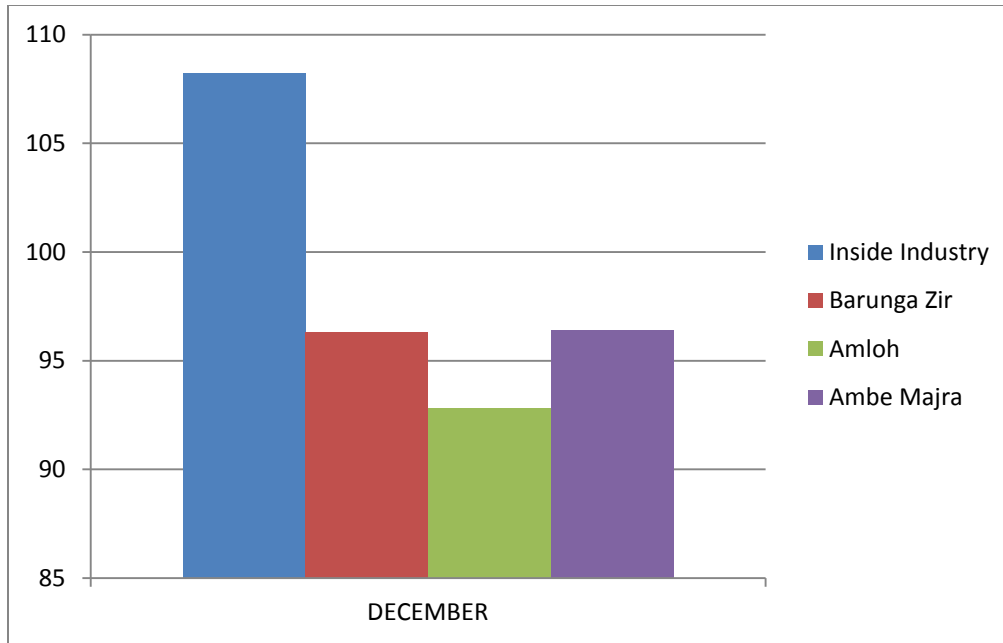

**Figure 9.0:- Value of PM 10 for the month of December**

It is clear from the graphs that for the month of December the values of PM are maximum as compared to other months the reason is clear that during the winter season the winds get stabled and dispersion of pollutants get reduced.

Result values shows that the values were found inside the Indian standards for pollutants except inside the industry where it is slightly above the standard. The value of PM 10 is greater inside the industry than other locations because there are different sources of dust emissions inside the industry which adds to existing concentrations.

Value of PM 10 is greater at Ambe-majra village than other villages due to the fact that the village is located near the main highway so the dust from the vehicular movement adds to the existing concentration.

The value at village Amloh is lesser than other locations because Amloh village is at greater distance from Mandigobindgarh village than other locations and the sampler was placed at residential area away from the road to get the value of particulate matters at residential area.

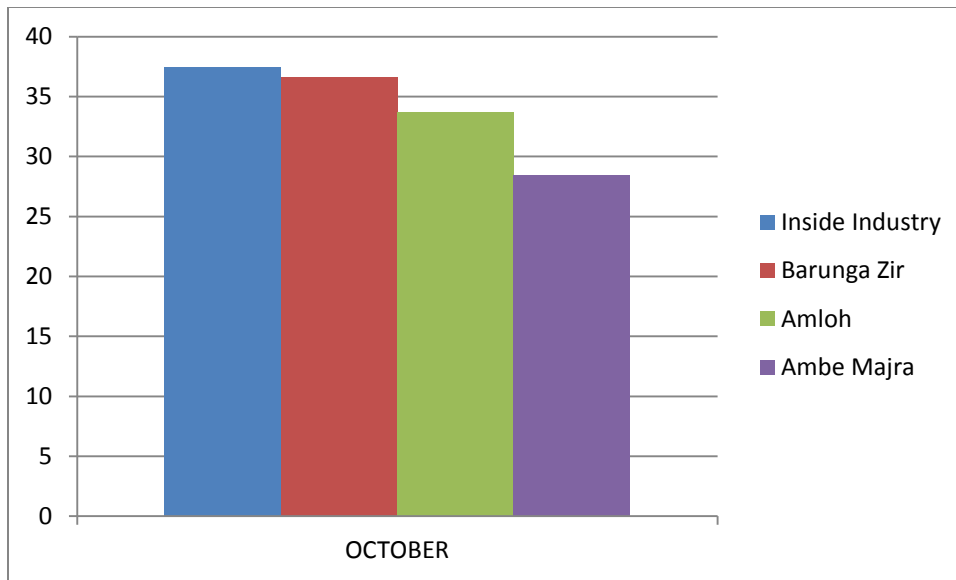

**Figure -10.0 :- PM 2.5 values for October Month.**

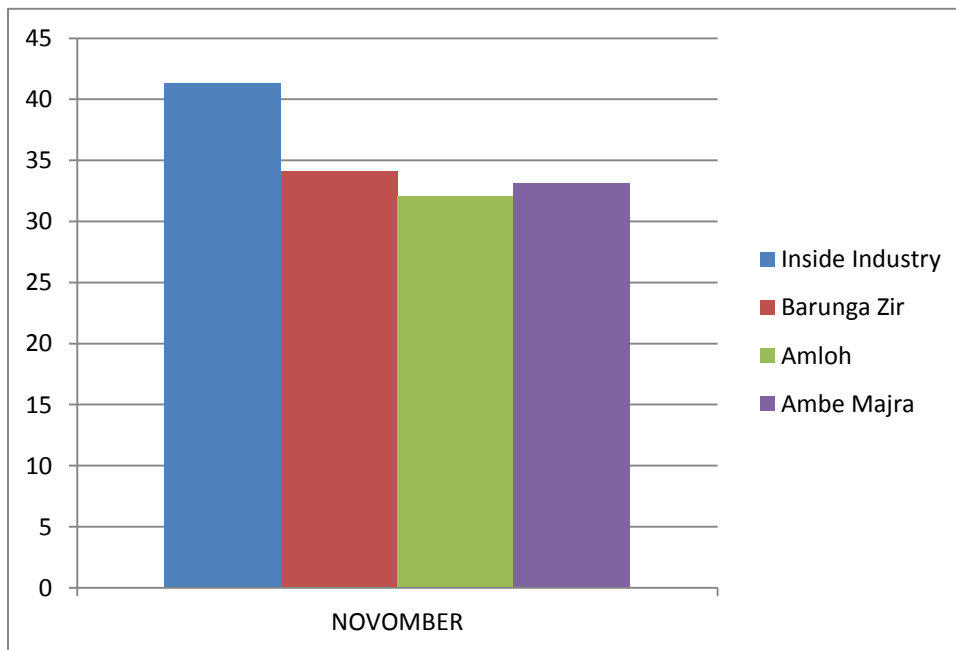

**Figure 11.0:- PM 2.5 Value for November Month**

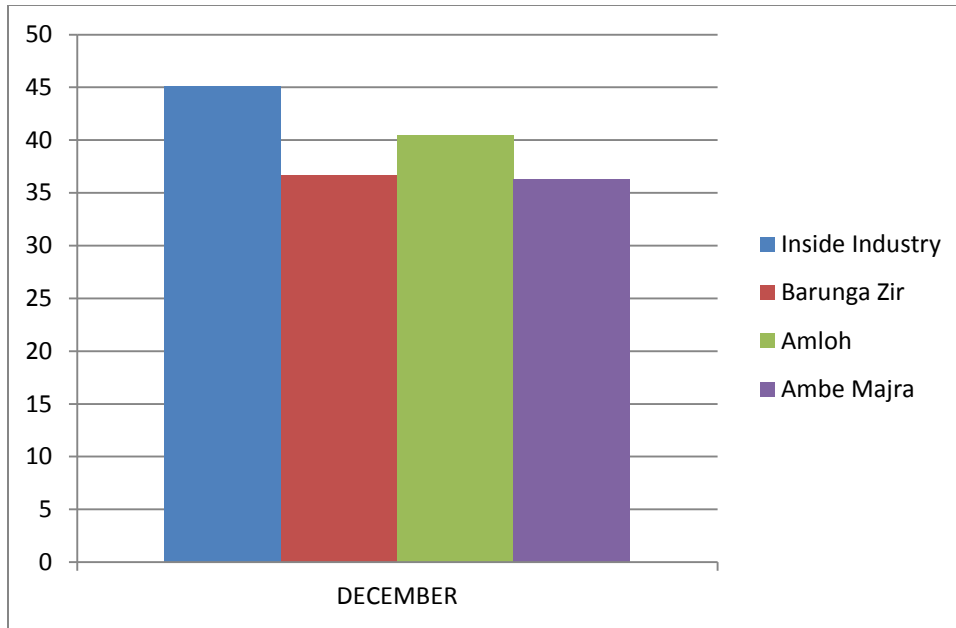

**Figure - 12.0 :- PM 2.5 Value for December month.**

Similarly for PM 2.5 the values are maximum for winter season highest for month of December. The reason is same that during winter season due to decrease in mixing height and stable winds the dispersion of Particulate matter decreases and their concentration increases. PM 2.5 concentration is also maximum at project site due to the different sources of emissions from the industry which contributes to the PM 2.5 values.

The value of PM 2.5 at Ambemajra is greater than other villages because this village is alongside the main highway and the pollution from the vehicles contributes to the existing PM 2.5 values.

The values are lowest for the village Amlah because this village is situated at more distance than other locations and the sampling for this location was one in residential area away from road.

Result values shows that the values were found inside the Indian standards for pollutants except inside the industry where it is slightly above the standard

## **5.0 CONCLUSION**

In this project the results obtained from the sampling of air at four locations comes close to the standards. The results obtained inside the industry which is slightly greater than the standards are justifiable due to its location which comes under critically polluted town of Mandi gobindgarh. Although the results obtained at village sites are under standards, but are high as compared to other villages of the state, this is due to its location which is near to industrial area, the polluted air get transported to these villages with winds . The value of pollutants is higher in village because the winds predominantly flow towards this direction from industrial area.

## 6.0 REFERENCES

1. Lynton K. Caldwell (1988) Environmental Impact Analysis (EIA): Origins, Evolution, and Future Directions, *Impact Assessment*, 6:3-4, 75-83.
2. Muraleedharan Valappil Ph.D. , Dimitri Devuyst Ph.D. & Luc Hens Ph.D. (1994) evaluation of the environmental impact assessment procedure in india, *Impact Assessment*, 12:1, 75-88.
3. Therivel and Morris (2001). *Methods of Environmental Impact Assessment*, Spon Press, 2001
4. Wathern, P. (1988). An introductory guide to EIA. In Wathern, P. (ed.), *Environmental Impact Assessment: Theory and Practice*, Boston: Unwin Hyman.
5. Glasson, J. Therivel, R. & Chadwick. A. (2005). *Introduction to Environmental Impact Assessment (3rd Ed)*, pp 125-155.
6. Kimbrough, e. S. And d. A. Vallero. Air Pollution Monitoring Site Selection by Multiple Criteria Decision Analysis. Chapter xx, *McGraw-Hill Yearbook of Science & Technology 2008* . McGraw-Hill Companies, New York, NY, (2007)
7. B. Sivertsen, , The air quality monitoring and management system for HCMC, Vietnam, Presented at BAQ conference, Agra, India, December 2004,
8. S. Larssen, R. Sluyter, C. Helmis, Criteria for Euroairnet - The EEA Air Quality Monitoring and Information Network, Technical Report No. 12, (1999), Jos Arts , Paula
9. Caldwell & Angus Morrison-Saunders (2001) Environmental impact assessment follow-up: good practice and future directions — findings from a workshop at the IAIA 2000 conference, *Impact Assessment and Project Appraisal*, 19:3, 175-185
10. Cichowicz R, Wielgosiński G, Fetter W. Dispersion of atmospheric air pollution in Summer and winter season. *Environmental Monitoring and Assessment*. 2017;189(12):605.
11. K Elminir, Hamdy. (2005). Dependence of urban air pollutants on meteorology. *The Science of the total environment*. 350. 225-37. 10.1016/j.scitotenv.2005.01.043.

12. Nautiyal, J., Garg, M., Kumar, M.S., Khan, A.A., Thakur, J.S., & Kumar, R. (2007). Air Pollution and Cardiovascular Health in Mandi-Gobindgarh, Punjab, India - A Pilot Study. International journal of environmental research and public health.
13. William T. White (1982) Site Selection as Environmental Impact Assessment, Impact Assessment, 1:3, 27-39
- 14 EIA Guidance manual metallurgical industries
15. The guidelines for selections of ambient air monitoring stations given in IS -5182 part 14, 2000 and; Guidelines for Ambient Air Quality Monitoring' by CPCB