

**PERFORMANCE EVALUATION OF HIGH-RATE SPACE-TIME
BLOCK-CODED WIRELESS SYSTEMS WORKING UNDER
NAKAGAMI FADING CHANNEL**

Thesis submitted towards the partial fulfilment of requirement for the
award of degree of

**MASTER OF ENGINEERING
IN
WIRELESS COMMUNICATION**

Submitted by:

Devendra Kumar

Roll No. 801263006

Under the guidance of

Dr. Amit Kumar Kohli

Associate Professor, ECED

T.U. Patiala



**ELECTRONICS AND COMMUNICATION ENGINEERING
DEPARTMENT**

THAPAR UNIVERSITY

(Established under the section 3 of UGC Act, 1956)

PATIALA – 147004, INDIA

JULY-2014

DECLARATION

I, **Devendra Kumar**, hereby declare that the work, which is being presented in the thesis entitled "**Performance Evaluation of High-Rate Space-Time Block-Coded Wireless Systems Working Under Nakagami Fading Channel**" by me in partial fulfilment of the requirements for the award of degree of Master of Engineering in Wireless Communication from Thapar University (Deemed University), Patiala, is an authentic record of my own work carried out under the supervision of **Dr. Amit Kumar Kohli**, Associate Professor, Electronics and Communication Engineering Department.

The matter presented in this thesis has not been submitted in any other University/Institute for the award of Master of Engineering

Date: 7th July 2014

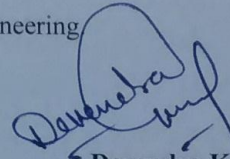

Devendra Kumar

Roll no: 801263006

This is to certify that the above statement made by the student is correct to the best of my knowledge and belief.

Date:

7/7/14

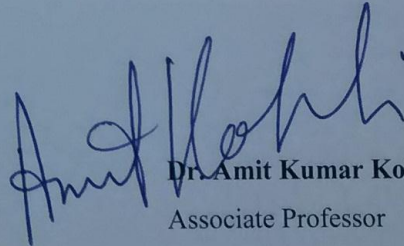

Dr. Amit Kumar Kohli

Associate Professor

ECED

Thapar University, Patiala

Countersigned by:

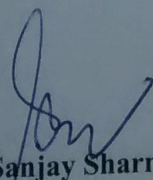

(Dr. Sanjay Sharma)

Professor and Head ECED

ECED, Thapar University, Patiala

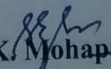

(Dr. S. K. Mohapatra)

Dean of Academic Affairs

Thapar University, Patiala

ACKNOWLEDGEMENT

I would like to give special thanks to my guide **Dr. Amit Kumar Kohli**, Associate Professor, ECED, Thapar University, Patiala, for his advice, kind assistance, and invaluable guidance. It has been a great honour to work under him.

I am also thankful to **Dr. Sanjay Sharma**, Prof. & Head, Electronics and Communication Engineering Department, for providing us with adequate infrastructure in carrying the work.

I am also thankful to **Dr. Kulbir Singh**, P.G. Coordinator, Electronics and Communication Engineering Department for the motivation and inspiration that triggered me for the report work.

I am greatly indebted to all of my friends who constantly encouraged me and also would like to thank all the faculty members of ECED for the full support of my work. I am also thankful to the authors whose work have been consulted and quoted in this work.

Devendra Kumar

ABSTRACT

Fading is one of the most challenging phenomena in wireless communication when a reliable communication path has to be established between transmitter and receiver. Fading is more prominent when there is no line-of-sight component, moreover it is more prominent in case of urban and suburban cities. Generally, the multipath fading amplitude distribution is modelled with Rayleigh probability distribution function (PDF). But when the fading is more severe, the Rayleigh model fails to characterize the exact channel characteristics. Therefore, a more accurate model, named m -Nakagami model may be employed to characterize the channel. However, Inter symbol interference (ISI), an another important issue that is again a matter of concern when frequency-selective fading case is considered. Frequency-selective fading is defined when signal bandwidth is greater than channel bandwidth. Thus, Frequency-selective fading causes ISI. The equalization is one of the methods that invert the effects of channel.

Orthogonal frequency division multiplexing (OFDM) may be the other useful technique which can be employed to mitigate the effect of ISI. Generally, in OFDM, each subcarrier undergoes flat fading since its bandwidth is smaller than the coherence bandwidth. OFDM converts frequency-selective channel into a number of flat fading channels by using cyclic prefix, but sub-bands of OFDM are disclosed to deep fading and may cause complete loss of sub-band information. To deal with this problem Space-time block coding is applied in OFDM, however it also introduces redundancy. By affixing CP at beginning of OFDM symbol block, the linear convolution associated with channel impulse response become a circular convolution, so inter-block interference is precluded.

In this thesis, we have made an effort to study space-time block coded (STBC) and high-rate STBC working under different fading wireless channels.

We have presented simulation results which demonstrates that in mobile environment at lower value of SNR for $m > 1$ (slow fading) effective throughput is high in case of both high-rate STBC as well as full-rate STBC when compared to $m = 1$ (Rayleigh fading) and effective throughput is low for $m < 1$ when $m = 1$ compared to for both systems.

Secondly, simulation results demonstrate that at high values of SNR (e.g. 6dB to 20dB) proposed low complexity zero forcing (ZF) receiver gives better effective throughput for the values of $m < 1$ and for $m = 1$ effective throughput is between $m < 1$ and $m > 1$. Whereas at lower values of SNR (e.g. 0dB to 6dB) proposed receiver achieves better effective throughput for the values of $m > 1$.

Keywords: Frequency-selective fading, PDF, m-Nakagami, OFDM, STBC, high-rate STBC, ZF, ISI, Time-selective fading.

TABLE OF CONTENTS

DECLARATION	i
ACKNOWLEDGEMENT	ii
ABSTRACT	iii
TABLE OF CONTENTS	iv
LIST OF ABBREVIATIONS	v
LIST OF FIGURES	vi
1. INTRODUCTION	1
1.1 Real Scenario of Today's Communication Environment	1
1.2 Problem Statements	5
1.3 Organization of the Thesis	5
2. LITERATURE REVIEW	7
3. FADING AND DIVERSITY	14
3.1 Fading	14
3.2 Small Scale Fading	14
3.3 Types of Small Scale Fading	15
3.3.1 Fast Fading	15
3.3.2 Slow Fading	15
3.3.3 Frequency Selective Fading	16
3.3.4 Flat Fading	17
3.4 Diversity	17
3.4.1 Advantages of Diversity Technique	18
3.4.2 Types of Diversity	18
3.4.2.1 Time Diversity	18
3.4.2.2 Frequency Diversity	18
3.4.2.3 Polarization Diversity	18
3.4.2.4 Spatial Diversity	19
3.4.3 Different Types of Combining Techniques For Space Diversity	20

3.4.3.1	Selection Diversity	20
3.4.3.2	Feedback or Scanning Diversity	21
3.4.3.3	Maximal Ratio Combining	22
3.4.3.4	Equal Gain Combining	22
3.5	Fading Models or Distribution	23
3.5.1	Rayleigh Distribution	23
3.5.2	Ricean Distribution	23
3.5.3	Gamma Distribution	24
3.5.4	Nakagami-m Distribution	24
4.	ORTHOGONAL FREQUENCY DIVISION MULTIPLEXING	26
4.1	OFDM System Model	26
4.1.1	Transmitter	26
4.1.1.1	Addition of Guard Band	28
4.1.1.2	Cyclic Prefix	28
4.1.1.3	Cyclic Suffix	29
4.1.1.4	Zero Padding	30
4.1.2	Channel Model	30
4.1.3	Receiver	31
4.2	STBC-OFDM	32
4.3	Simulation Results	33
4.3.1	Comparison of STBC with EGC and MRRC	33
4.3.2	Comparison of STBC-OFDM For $m=0.75, 1, 1.25$	34
5.	SPACE TIME BLOCK CODE	36
5.1	Two Branch Transmit Diversity	36

5.1.1	Encoding and Transmission Sequence	37
5.2	High-Rate STBC	38
5.2.1	System Model of High-Rate STBC	39
5.2.2	Transmission Model	39
5.2.3	Received Signal Model of High-Rate STBC	40
5.2.3.1	For Frequency Flat Condition	41
5.3	Proposed Low Complexity ZF Receiver	42
6.	SIMULATION RESULTS	45
6.1	SER Performance of High-Rate STBC and Alamouti STBC in Rayleigh Fading Channel	45
6.2	SER Performance of Alamouti STBC and High rate STBC in m-Nakagami Fading Channel For Frequency Flat Condition	46
6.3	SER Performance of Proposed Receiver For Alamouti STBC and High- Rate STBC in m-Nakagami Fading Channel For Frequency-Selective Condition	47
7.	CONCLUDING REMARKS AND FUTURE SCOPE	49
7.1	Concluding Remarks	49
7.2	Future Scope	50

REFERENCES

LIST OF ABBREVIATIONS

ACE	Active Constellation Extension
ADSL	Asymmetric Digital Subscriber Line
AWGN	Additive White Gaussian Noise
A/D	Analog to Digital
BER	Bit Error Rate
BPSK	Binary Phase Shift Keying
BTS	Base Transceiver Station
CDF	Cumulative Distribution Function
CDMA	Code Division Multiple Access
CFR	Channel Frequency Response
CP	Cyclic Prefix
CSI	Channel State Information
DAB	Digital Audio Broadcasting
DFT	Discrete Fourier Transform
DVB	Digital Video Broadcasting
D/A	Digital to Analog
ECC	Error Correction Codes
FDE	Frequency Domain Equalization
FDMA	Frequency Division Multiplexing
FER	Frame Error Rate
FFT	Fast Fourier Transform
FIR	Finite Impulse Response
GI	Guard Interval
IBI	Inter Block Interference
ICI	Inter Carrier Interference
IDFT	Inverse Discrete Fourier Transform
IEEE	Institute of Electrical and Electronics Engineers
IFFT	Inverse Fast Fourier Transform
ISI	Inter Symbol Interference
LAN	Local Area Network
LCF	Linear Complex Field
LOS	Line of Sight

LMS	Least Mean Square
LS	Least Square
LTE	Long Term Evaluation
MIMO	Multi Input Multi Output
ML	Maximum Likelihood
MRRC	Maximum Ratio Receive Combining
OC	Orthogonal Code
OFDM	Orthogonal Frequency Division Multiplexing
PAM	Pulse Amplitude Modulation
PAPR	Peak to Average Power Ratio
PCC	Polynomial Cancellation Code
PDF	Probability Density Function
PSK	Phase Shift Keying
PCU	Per Channel Use
P/S	Parallel to Serial
QAM	Quadrature Amplitude Modulation
QPSK	Quadrature Phase Shift Keying
RF	Radio Frequency
RMS	Root Mean Square
SC	Single Carrier
SER	Symbol Error Rate
SF	Space Frequency
SFBC	Space Frequency Block Code
SI	Side Information
SNR	Signal to Noise Ratio
ST	Space Time
STBC	Space Time Block Code
STC	Space Time Code
STTC	Space Time Trellis Code
Wi-MAX	Worldwide Interoperability For Microwave Access
ZF	Zero Forcing
3G	Third Generation
3GPP-LTE	Third Generation Partnership Project Long Term Evolution

LIST OF FIGURES

Fig. 1.1. Wireless Communication System in Urban and Sub-Urban Area	1
Fig. 3.1. Frequency Selective Fading Channel Characteristics	16
Fig. 3.2. Flat Fading Channel Characteristics	17
Fig. 3.3. Receiver Space Diversity	19
Fig. 3.4. Transmit Space Diversity	19
Fig. 3.5. Transmit-Receiver Space Diversity	19
Fig. 3.6. Generalize Diagram of Antenna Diversity	21
Fig. 3.7. Scanning Diversity	21
Fig. 3.8. Maximum ratio combiner	22
Fig. 4.1. Block diagram of OFDM system	27
Fig. 4.2. OFDM symbols with cyclic prefix	28
Fig. 4.3. OFDM symbols with cyclic suffix	29
Fig. 4.4. OFDM symbols with zero padding	30
Fig. 4.5. Time domain implementation of STBC-OFDM system	33
Fig. 4.6. BER Performance of STBC system with EGC and MRC schemes	34
Fig. 4.7. SER Performance of STBC-OFDM in m-Nakagami fading environment	35
Fig. 5.1. Two branch transmit diversity scheme	36
Fig. 5.2. Block diagram of rate-5/4 STBC for QAM Modulation	40
Fig. 6.1. Comparison of effective throughput: Alamouti STBC vs high-rate STBC for Rayleigh fading channel, N=64, QAM and 2 TX	45
Fig. 6.2. Performance of Alamouti STBC and High rate STBC in m-Nakagami fading channel for frequency flat condition	46
Fig. 6.3. Performance of proposed receiver for Alamouti STBC and High-rate STBC in m-Nakagami fading channel for frequency-selective condition	47

INTRODUCTION

1.1 Real Scenario of Today's Communication Environment

In wireless communication systems, Signals travel from source to destination through wireless channels. These signals get reflected, scattered and diffracted through different obstacle like Big High-rise Buildings, Temples, Malls, Industries, etc. Due to these effects multiple copies of information bearing signals are generated which follows the different path to propagate. Multiple propagation paths exist from a transmitter to a receiver due to the lack of Line of sight between them as shown in Fig. 1.1.

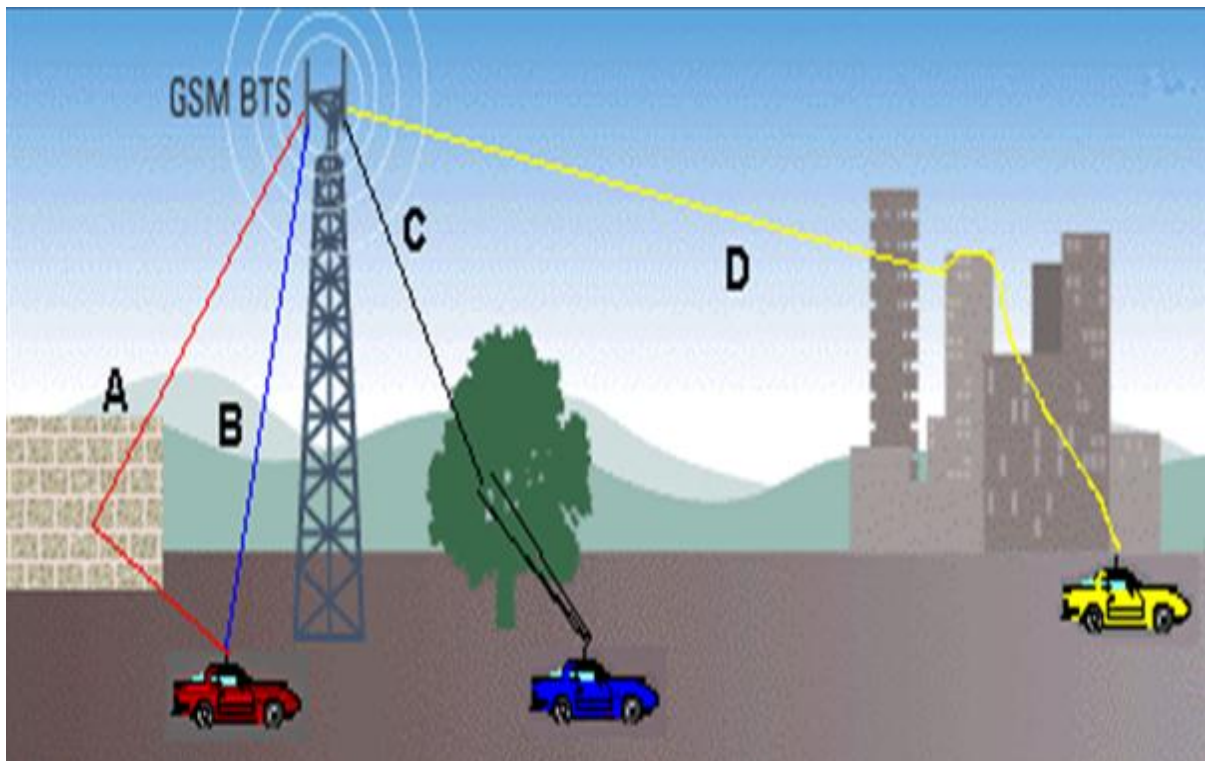

Fig. 1.1. Wireless Communication System in Urban and Sub-Urban Areas.

Signal copies following different paths can undergo different attenuation, delays, distortions and phase shifts. Constructive and destructive interference effect will occur at the receiver. When destructive interference occurs, the signal power can be significantly diminished. This phenomenon called as a fading [1].

The performance of a wireless communication system (in terms of probability of error) can be eventually reduced by fading. Very often, especially in mobile communications, multiple propagation paths exist which are also time-varying in nature. The result is a time-varying fading channel. Communication through these channels can be difficult. To make communication reliable, some special techniques may be required to make error or noiseless communication [1].

In addition, the vehicle motion introduces a Doppler shift resulting in broadening of the signal spectrum. Measurements confirm that the short term statistics of the resultant signal envelope approximate by a Rayleigh distribution.

Multipath fading may also be frequency selective which is the complex fading envelope of the received signal at one frequency may be only partially correlated with the received envelope at a different or another frequency. This uncorrelation is due to the difference in propagation time delays associated with the various scattered waves making up the total signal. The spread in arrival times, known as delay spread, causes transmitted data pulses to overlap, resulting in inter symbol interference (ISI) [1].

In a typical urban environment, a spread of several microseconds and greater can be occasionally expected. In order to use the assigned spectrum more efficiently, the available radio channels are reused at different locations within the overall cellular service area. Thus, mobiles simultaneously using the same channel in different locations can interfere with each other. This is termed as co-channel interference.

In addition, there is a long-term variation of the local mean of the received signal, called shadow fading. Shadow fading in a mobile radio environment is caused by large obstacles blocking the transmission path.

Therefore wireless communication systems encounter multipath fading which is relatively deep, i.e. the signals fade completely away, whereas at other times the fading may not cause the signal to fall below a useable strength. The fading channel could be modeled with m -Nakagami distribution if the fading is severe compared to the Rayleigh distribution model. The Rayleigh distribution is a special case of m -Nakagami when $m = 1$ [2].

In multi path channels, small scale fading is the main issue to concentrate for communication engineer. Due to this small scale fading, the signal strength gets rapid fluctuations over a small travel distance. In Wireless communication, proper Coding and Transmission schemes are used to reduce the Fading Effect in which different diversity techniques are used which are as follows [1]:

- Time diversity: Replicas of the Original information containing signal are transmitted in different - different time slots, where the separation between the time slots is greater than the coherence of the channel.
- Frequency diversity: In this case, replicas of the Original information containing signal are transmitted in different frequency bands or slots, where the separation between the frequencies is greater than the coherence bandwidth of the channel.
- Antenna (space) diversity: In this case, multiple antennas used to transmit the replicas of original information bearing signal. It has been observed that antennas with a spacing of more than half a wavelength leads to spatially uncorrelated channels. The transmission of the replicas of the information bearing signal over these uncorrelated spatial channels leads to spatial diversity.

Combination of multiple antennas and time codes can be used to occupy spatial diversity. Space-time Codes (STC) were first introduced by G. J. Foschini from Bell Labs in 1996 as a novel means of providing transmitter diversity for the multiple antenna fading channel.[3]

There are two main approaches of STC:

- Space-time Trellis Codes (STTC)
- Space-time Block Codes (STBC)

The original STTC were proposed by Tarokh, these original STTC design were hand crafted and therefore, it is very complex in Nature. In subsequent years, a large number of research proposals were published which proposed new code construction or perform

systematic searches for different convolution STTC or some variant of the original design criteria introduced by Tarokh.

The maximum diversity can be occupied using the Space-Time Block Codes (STBC) which is proposed by Alamouti [4] and Tarokh which provide a simple transmit diversity scheme in a flat fading channel. The MIMO techniques generally used in flat frequency channels. Orthogonal Frequency Division Multiplexing (OFDM) converts a wide band frequency to multiple narrow bands having flat frequency. So we can use MIMO with OFDM to transmit data in wide band frequencies achieving high efficiency and low symbol error rate. Space time or space frequency along with OFDM can utilize the orthogonal transmission by Alamouti Scheme [4] as described by following equations,

$$\begin{matrix} \longrightarrow & \text{Space} \\ \begin{bmatrix} X_1 \\ X_2 \end{bmatrix} = \begin{bmatrix} X_1 & X_2 \\ -X_2^* & X_1^* \end{bmatrix} & \downarrow \text{Time} \end{matrix} \quad (1.1)$$

Orthogonal frequency division multiplexing (OFDM) reduces receiver complexity in wireless broadband systems, and it currently been use in wireless broadband multi-antenna systems. It is also a promising modulation technique to be used in multiple-input multiple-output (MIMO) systems. The orthogonal and independent sub-channels in OFDM are achieved by appending a cyclic prefix to each transmitted block of data, which is then discarded at the receiver. The cyclic extension results in overhead transmission time and reduces the rate & efficiency of the communications link. This overhead in time is always present, since the length of the cyclic prefix is usually chosen to cover the longest channel spread.

Cyclic guard interval (GI) is inserted between two sub-carriers at each antenna in OFDM provide a flat fading channel. Therefore, space-time block codes can be used in conjunction with OFDM. A cyclic prefix (CP) instead of guard interval appended in the head of each transmitted block to eliminate inter block interference (IBI), makes all channel matrices circulant. However, in the frequency-selective broadband channels, the symbol duration is increased significantly as compared to single carrier of the same total bandwidth because of the broadband channel is subdivided into orthogonal

narrowband channels.

STBC was first designed assuming a narrowband wireless system which is a flat fading channel. However, when used over frequency selective channels a channel equalizer has to be used at the receiver along with the space-time decoder. For the STBC, the channel equalization problem was addressed by modifying the original Alamouti scheme in such a way that it is use over frequency selective channel, and hence the equalization is a very easier method to implement. Therefore STBC was used in conjunction with OFDM.

OFDM is used to convert the frequency selective channel into a set of independent, parallel, and flat-frequency sub- channels or sub carriers. The Alamouti scheme is then applied to two consecutive subcarriers or two consecutive OFDM block.

1.2 Problem Statement

This thesis consists the following research work

1. First STBC wireless communication system are investigated for 2 Tx and 1 Rx and compare with 1 Tx and 1 Rx.
2. Next we evaluate STBC-OFDM system and compared for different combining scheme like equal gain combining, maximum ratio combining, selective combining.
3. Subsequently, we have evaluated high-rate STBC system for frequency flat condition and compared to STBC system with respect to effective throughput.
4. Further, we have evaluated the performance of high-rate STBC and STBC in m-Nakagami fading environment.
5. We have proposed low complexity zero forcing for high rate STBC to mitigate the effect of ISI and compared with the STBC with respect to effective throughput in m-Nakagami fading environment.

1.3 Organization of Report

This report is organized in seven chapters

- Chapter-1, Introduction to real scenario of today's communication system and

how problem can realize using different techniques.

- Chapter-2, work done in the area of STBC and high-rate STBC, Fading and Nakagami Channel.
- Chapter-3, Basic phenomena behind Fading effect and Types of Fading, different combining scheme and different types of fading models in wireless communication.
- Chapter-4, discuss the Basic Principal and Implementation of OFDM and briefly describe how STBC is implemented in OFDM.
- Chapter-5, We describe how High-rate STBC is implemented and deep mathematical description of High-rate STBC implementation in communication system
- Chapter-6, simulation results of STBC, STBC-OFDM and High-rate STBC for various fading channels.
- Finally in Chapter-7, describe the summary of work done and future work to be carried out to fulfill the research work.

LITERATURE SURVEY

In Ref. [2], For frequency-selective Nakagami-fading channels, the magnitudes of the channel frequency responses to be also Nakagami-m distributed RVs whose fading and mean power parameters are explicit functions of those of the channel impulse responses. Based on the new results, one can design and evaluate OFDM systems over Nakagami-m fading channels in the frequency domain. In this letter, the BER performance of a multiple receive antenna OFDM system with BPSK and QFSK signals over correlated frequency-selective Nakagami-m fading channels has been evaluated.

In Ref. [4], this research work proposed a two-branch transmit diversity scheme which is Using two transmit antennas and one receive antenna. This scheme provides order of diversity same as maximal-ratio receiver combining (MRRRC) with one transmit antenna and two receive antennas. It is also proved that this scheme may easily be generalized for two transmit antennas and M receive antennas to give diversity order of $2M$. The new scheme does not require any additional bandwidth or any feedback from the receiver to the transmitter and its computation complexity is similar as MRRRC.

In Ref. [6], Fourier transform data communication system is a realization of frequency-division multiplexing (FDM) in which discrete Fourier transforms are computed as part of the modulation and demodulation processes. To eliminate the bunks of subcarrier oscillators and coherent demodulators generally required in FDM systems, a completely digital implementation could be made around a special-purpose computer that can perform the fast Fourier transform. In this, the system is explained and the effects of linear channel distortion are evaluated. Signal design criteria and equalization algorithms are derived and explained. A differential phase modulation scheme is presented that avoids any equalization.

In Ref. [10], there has been an increasing interest in providing high rate services such as video-conferencing, multimedia Internet access and wide area network over wideband wireless channels. Wideband wireless channels available in the PCS band (2 GHz) have

been envisioned to be used by mobile and stationary (low Doppler) units in a variety of delay spread profiles. This is a challenging task, given the limited link budget and severity of wireless environment, and calls for the development of novel robust bandwidth efficient techniques which work reliably at low SNRs. To this end, we design a space time coded orthogonal frequency division multiplexing (OFDM) modulated physical layer. Space-time code was previously proposed for narrowband wireless channels. STC codes have spectral efficiency and operate at very low SNR (within 2-3 dB of the capacity). On other side, OFDM is matured as a modulation scheme for wideband channels. They combine these two in a natural manner and propose a system which achieved data rate 1.5-3 Mbps over a 1 MHz bandwidth channel. This requires 18-23 dB receive SNR at a frame error probability of 10^{-2} with two transmit and one receive antennas.

In Ref. [11], this research paper proposed a space-time block-coded orthogonal frequency-division multiplexing (STBC-OFDM) scheme for frequency-selective fading channels which does not require channel knowledge either at the transmitter or at the receiver. The decoding algorithm is based on generalized maximum-likelihood sequence estimation. Further they investigate the performance of the proposed scheme over two-tap Rayleigh fading channels.

In Ref. [12], A new paradigm space time block coding is proposed for communication over Rayleigh fading channels using multiple transmit antennas in which data is encoded by using a space time block code and encoded data is split into N streams which has to be transmitted simultaneously using N transmit antennas. The received signal at each receiver antenna is a linear superposition of the N transmitted signals distracted by noise. Maximum-likelihood decoding is acquired in a simple way through disconnect of the signals transmitted from different antennas rather than joint detection. This technique uses the orthogonal property of space time block code and provide a maximum-likelihood decoding algorithm which is based only on linear processing at the receiver. Space-time block codes are designed to achieve the maximum diversity order for a given number of transmit and receive antennas subject to the constraint of having a simple decoding algorithm. The classical mathematical framework of orthogonal designs is

applied to construct space-time block code. It is shown that space-time block codes constructed in this way only exist for few irregular values of N . Subsequently, a generalization of orthogonal designs is shown to provide space-time block codes for both real and complex constellations for any number of transmit antennas. These codes achieve the maximum possible transmission rate for any number of transmit antennas using any arbitrary real constellation such as PAM. For an arbitrary complex constellation such as QAM, space-time block codes are designed that achieve $1/2$ of the maximum possible transmission rate for any number of transmit antennas. For the specific cases of two, three, and four transmit antennas, space-time block codes are designed that achieve, respectively, all, $3/4$, and $3/4$ of maximum possible transmission rate using arbitrary complex constellations. The best tradeoff between the decoding delay and the number of transmit antennas is also computed and it is shown that many of the codes presented here are optimal.

In Ref. [13], this research work proposed a new rate- $5/4$ full-diversity orthogonal space-time block code (STBC) for QPSK and 2 transmit antennas (TX) by elaborating the signalling set from the set of quaternions used in the Alamouti [7] code. In this paper researchers using Selective power scaling of information symbols to guarantee full-diversity while maximizing the coding gain (CG) and minimizing the transmitted signal peak-to-minimum power ratio (PMPR). The optimum power scaling factor is derived analytically and shown to exceed schemes based only on constellation rotation while still enjoying a low-complexity maximum likelihood (ML) decoding algorithm.

In Ref. [15], they proposed an iterative interference cancellation scheme for OFDM signals with blanking nonlinearity in impulsive noise channels. By decomposing the blanking nonlinearity output into the signal term, ICI term, and impulsive noise term, the ICI caused by blanking nonlinearity can be iteratively reconstructed and subtracted from the DFT outputs to improve system SER performance significantly.

In Ref. [16], this paper proposes windowing nonlinearity scheme to detect and remove the over-sampled impulsive interference in OFDM systems. The analysis of the false detection probability (FDP) and successful detection probability (SDP) is given. The results indicate that the proposed scheme detects impulsive noise efficiently. In addition,

the closed-form expressions for the FDP and SDP of blanking nonlinearity scheme which is widely used to remove impulsive interference are also derived.

In Ref.[17], the impulsive noise rejection in BPSK modulated OFDM symbol which is commonly used to transmit frame control information in physical layer frame. At this condition, the OFDM symbol in time domain is symmetry. They propose a new algorithm to mitigate the impulsive noise affect based on this symmetry. An impulsive noise model and an OFDM simulation platform are built for testing the algorithm. Simulation results show that our method easily implement and has a good performance in impulsive noise environment.

In Ref.[18], Present theoretical analysis of the performance of orthogonal multiplexing data transmission that subjects to a number of degrading factors commonly encountered by a practical operating system. The factors which can be considered jointly are sampling time error, carrier phase offset, and non-ideal phase characteristics of transmitting and receiving filters. Performance measured by the familiar criterion of eye opening of the received data signal. A closed-form expression for the eye opening is obtained. this shows that the lengthy nonlinear functions in the solution can be closely approximated by simple piecewise linear functions for parameter values of interest. The optimum settings of the sampling time and the carrier phase are determined for given filter phase distortion. Also, considering all elements, simple formulas are developed for computing inter channel interferences, inter symbol interference, and the resulting eye opening. Simple relationships between the eye opening and filter phase distortion are explored, and a concept of parametric eye is introduced to aid in filter design.

In Ref. [19], This research presents the characterization of impulse environment effects on the space-time block coded orthogonal frequency division multiplexing (STBC-OFDM) symbol reception, in this technique the conventional OFDM system is combined with the antenna-diversity or spatial-diversity in order to acquire the high data transmission rates. Further, weak impulse noise can be combated by the longer OFDM symbol duration, because the total energy of noise spreads among the simultaneously transmitted OFDM sub-carriers regardless of the impulse noise energy distribution. Specifically, the main focus of the proposed work was on “noise bucket” effect, in

which the STBC-OFDM system is considered to be working in the impulsive environment. It is shown by simulation results that for the occurrence of a significant number of impulses per symbol duration, the noise distribution at the input of the receiver's final decision device is approximately Gaussian. Therefore for simulation purpose, the impulsive environment may be generated by the incorporation of equivalent Gaussian noise. Besides, some simulation results are presented using 16-QAM / STBC-OFDM system to give some insight into the symbol error rate variations with respect to the different number of sub-carriers and characteristics of impulsive environment.

In Ref. [20], this paper proposed a simulation model for m fading channels, $m < 1$. The model reveals that an m fading channel, $m < 1$, having a given Doppler power spectrum can be simulated by generating a complex Gaussian process and a square-root-beta random process. Application of the proposed model to simulate correlated m fading channels has also been demonstrated. In numerical examples, it has been shown that statistical properties of the samples generated from the use of the proposed model are close to the required ones.

In Ref. [21], the Nakagami fading by using sum of sinusoidal using Rayleigh and Ricean fading is described in this paper. The received signal for Rayleigh can be expressed as

$$R_{nakagami} = R_{ray}e^{(1-m)} + R_{rice}(1 - e^{(1-m)}) \quad (2.1)$$

Where R_{ray} and R_{rice} are envelopes of Rayleigh and Ricean channels respectively. Their method of generation is given in this paper. By adopting sum of sinusoidal approach for received signal generation and expressing it in in-phase and quadrature form for both Rayleigh and Ricean fading.

$$R(t) = \sqrt{I(t)^2 + Q(t)^2} \quad (2.2)$$

Where $I(t)$ and $Q(t)$ are the in-phase and quadrature components.

In Ref. [22], High mobility causes performance-limiting ICI in MIMO OFDM receivers. S. Lu et al. designed a novel SFBC-OFDM scheme and showed how to integrate it with FIR ICI- mitigating equalization. To compute the equalizer coefficients, they showed how to estimate the fast time-varying MIMO channel matrix efficiently by exploiting its sparse and banded structure in the time and frequency-domains, respectively. Their simulation results for the Digital Video Broadcasting-Handheld (DVB-H) system demonstrate the effectiveness of the proposed scheme.

In Ref. [23], an inter-carrier interference (ICI) occurs in an orthogonal frequency division multiplexing (OFDM) system when a channel is rapidly time-varying. Polynomial cancellation code (PCC) to suppress this ICI, and uses a linear complex field (LCF) code as a transmit-diversity technique to make the transmission rate compatible up to $\frac{nT}{nT+1}$ where nT is the no. of transmit antennas used in the system. The conventional orthogonal code (OC), such as the Alamouti code, with accompanying PCC cannot achieve this rate. Both analysis and simulation results verify that the proposed scheme can achieve higher channel capacity as well as lower bit error rate (BER) than the other schemes in rapidly time-varying channels, even with a linear receiver and inaccurate channel estimation.

In Ref. [24], quasi-orthogonal STBC (QO-STBC) is used instead of the conventional O-STBC with OFDM MIMO systems, thus resulting in a system called quasi-orthogonal space-frequency block coding (QOSFBC). This approach therefore, helps in increasing the transmission rate of STBC-MIMO-OFDM. This paper discusses the employment of a Zero-forcing detector, which is a low complexity receiver and removes the error floor completely.

As it is a known fact, that QO-STBC can offer full transmission rate when it is compared to the partial rate provided by OSTBC. On using computer simulation, the QO-SF-OFDM system is proved to perform better than the O-STBC based SF-OFDM system and on the same time, this improves the code transmission rate.

In Ref. [25], this paper proposed orthogonal frequency division multiplexing (OFDM) for high data rate narrowband power line communication (PLC) in the frequency bands up to 500 kHz. In narrowband PLC, the performance is badly affected by impulsive noise with

very large amplitudes with short durations. Simple iterative impulsive noise suppression algorithms can effectively give better error rate performance in OFDM systems. However, the convergence speed depends on the number of subcarriers, N . For $N \leq 256$, the algorithms converge slowly or not even at all. These papers extend the iterative receiver design to enable a fast convergence for $N > 64$ and to improve the error rate performance for $N \leq 64$. These extensions include

- (1) A clipping and nulling technique at the input of the iterative algorithm
- (2) A novel low complexity syndrome decoder which uses the redundancy that is transmitted for synchronization or other purposes. Simulation results are showing the improvement in error rate.

FADING AND DIVERSITY

3.1 Fading

Number of quite simple and precise statistical models for fading channels which rely on the exact propagation environment and underlying communication scenario has been discussed. The statistical models are dependent on evaluation made for communication system or bandwidth allocation. Propagation models have mainly discussed on predicting the average received signal strength at a defined distance from transmitter, as well as the variability of signal strength in close spatial proximity to a desired location. Large scale propagation models determine the mean signal strength for any source-destination separation, thereby estimating the radio coverage of source.

3.2 Small Scale Fading

Small scale fading defines as the fast variations of the amplitude, phases or multipath delays of radio signal over small time interval or distance travelled, so that large scale path loss effects may be ignored. In small scale fading, power of the signal received at destination may differ by as much as three or four order of magnitude (30 or 40 dB) when destination is moved by small distance.

Another bad effect of mobile channel is Doppler shift which is due to relative motion between mobile station and source. Doppler shift describe the apparent frequency shift that each multipath feels due to relative motion between mobile station and source. If moving object is travelling in the direction of arrival of wave, the Doppler shift is positive that is apparent received frequency is increased and if moving object is travelling away from the direction of arrival of wave, then Doppler shift is negative. Multipath, Inter symbol interference and Doppler shift all are associated to variability that is because of motion of user and different varieties of environments that signal travels through. Altogether effects of these process results in decrease in signal strength at receiver, poor mobile receiver performance and hence not satisfactory quality of service of wireless system. Figure shows multipath propagation of the signal [1].

3.3 Types of Small Scale Fading

Depending on the relation between the signal parameters such as bandwidth, symbol period etc. and channel parameters such as root mean square delay spread and Doppler spread, various transmitted signals will undergo different types of fading. The Small scale signal fading is because of time dispersion and frequency dispersion mechanism in mobile channel could be sorted out into four major categories which depends on nature of the transmitted signal, channel and mobile velocity.

3.3.1 Fast Fading

In frequency domain, distortion of signal is because of fast fading increases with increasing Doppler spread as compare to transmitted signal bandwidth.

$$T_S > T_C$$

$$B_S < B_D$$

Where T_S is the symbol period, T_C is the coherence time, B_S is the bandwidth of symbol and B_D is the Doppler spread. Fast fading channel only deals with rate of change of channel due to motion.

3.3.2 Slow Fading

In the frequency domain, bandwidth of signal is much higher than the Doppler spread of the channel. Therefore slow fading occurs if

$$T_S \ll T_C$$

$$B_S \gg B_D$$

where T_S is the symbol period, T_C is the coherence time, B_S is the bandwidth of symbol and B_D is the Doppler spread.[1]

3.3.3 Frequency Selective Fading

The channel creates frequency selective fading on the received signal, if the channel has a fixed gain and linear phase response over the bandwidth which is smaller than bandwidth of transmitted signal.

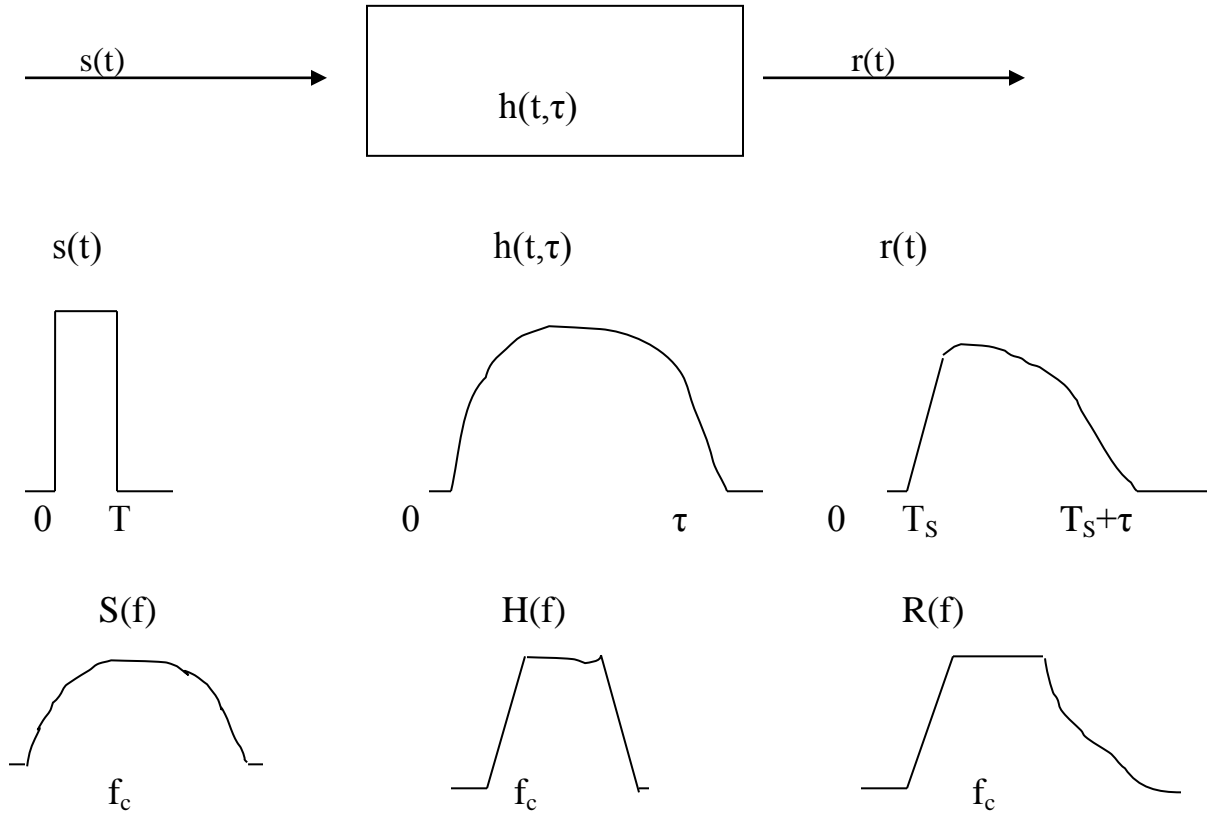

Fig. 3.1. Frequency Selective Fading Channel Characteristics

Frequency selective fading channels are also called as wideband channels as bandwidth of signal is wider than bandwidth of channel impulse response.

$$B_S > B_C$$

And
$$T_S < \sigma_\tau$$

Where B_S is bandwidth of transmitted signal, B_C is coherence bandwidth of channel, T_S is symbol period and σ_τ is root mean square delay spread.

3.3.4 Flat Fading

In flat fading, symbol time is much larger than multipath time delay spread of channel. Flat fading channel are also called as narrowband channel.

$$B_S \ll B_C$$

And
$$T_S \gg \sigma_\tau$$

Where B_S is bandwidth of transmitted signal, B_C is coherence bandwidth of channel, T_S is symbol period and σ_τ is root mean square delay spread [5].

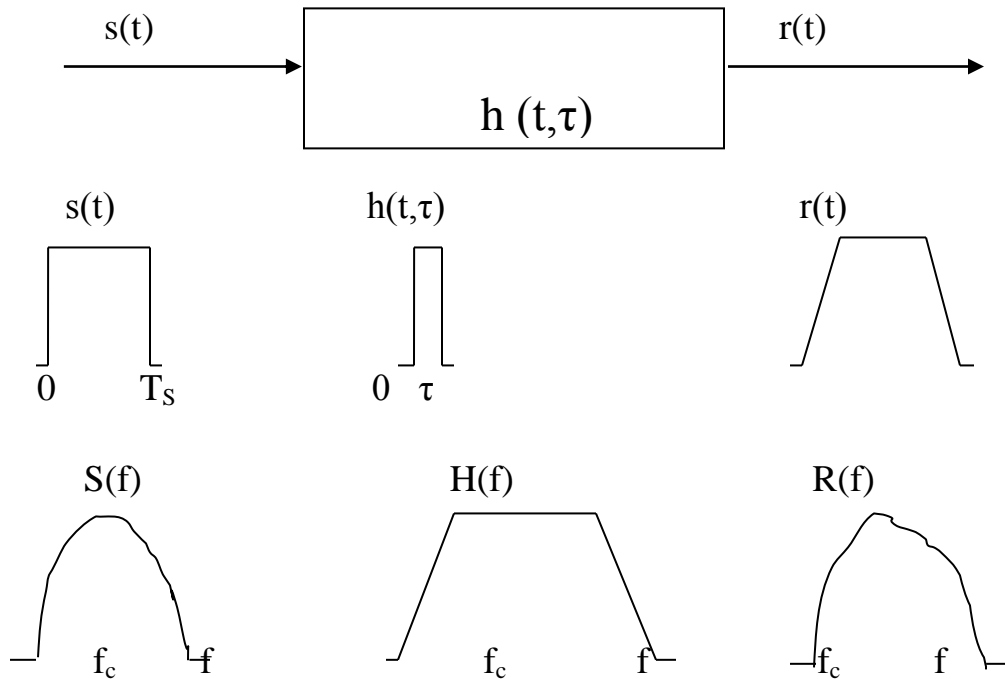

Fig. 3.2. Flat Fading Channel Characteristics

3.4 Diversity

The main objective of Diversity is to combine the multiple signals in such a manner that effect of fading is reduced. Diversity is used to reduce the effect and interval of the fades occurred by a receiver in frequency selective fading environment.

3.4.1 Advantages of Diversity Technique

- Unlike Equalization, no training overheads are required in case of diversity.
- It provides significant link improvement with less added cost.
- It exploits random nature of wave propagation by finding uncorrelated signal paths for communication.

3.4.2 Types of Diversity

In this section, we study the type of diversity technique used in wireless environment. Usually diversity systems are employed at receiver instead of transmitter since no more transmitted power is required to employ the receiver diversity [1].

3.4.2.1 Time Diversity

Time diversity technique is applicable for transmission of digital data over fading channel. In time diversity, same data is transmitted over channel at different time intervals. Separation between multiple copies of the transmitted signal should be greater than coherence time. Coherence time (Δt) is defined as time interval over which the channel impulse response is fixed. There is no need to increase the numbers of antenna.

3.4.2.2 Frequency Diversity

In frequency diversity scheme transmission of same signal at different frequency slots and the frequency separation between them should be at least coherence bandwidth (Δf). Coherence bandwidth is defined as range of frequencies over which channel can be considered to be flat.

3.4.2.3 Polarization Diversity

Transmitted signals may be in horizontal or vertical electric fields which are not correlated at the transmitting end and receiving end. The horizontal and vertical polarization components E_x and E_y transmitted by two polarized antennas at the transmitting end and received by two polarization antennas at receiving end which

provides two uncorrelated fading signals. Polarization diversity results in 3db power loss at transmitting site since power is divided into different polarized antennas.

3.4.2.4 Spatial Diversity

In spatial diversity, multiple antennas are placed at different spatial locations which are separated by small distance (few wavelengths) and they will not experience fading of signal altogether at the same time instant. There are several configurations of spatial diversity like: Transmitter Space diversity, Receiver Space diversity and Transmitter-Receiver Space. M different antennas used at transmitter or receiver site will experience independent fading of signal.

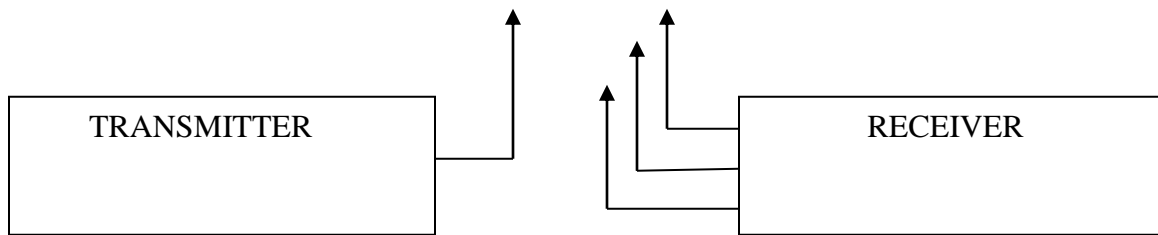

Fig. 3.3. Receiver Space Diversity

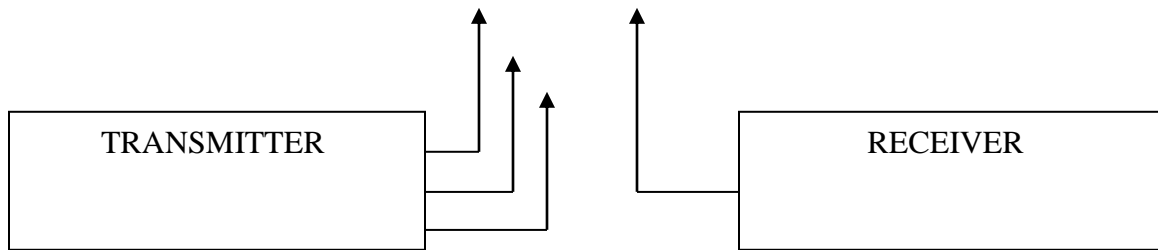

Fig. 3.4. Transmit Space Diversity

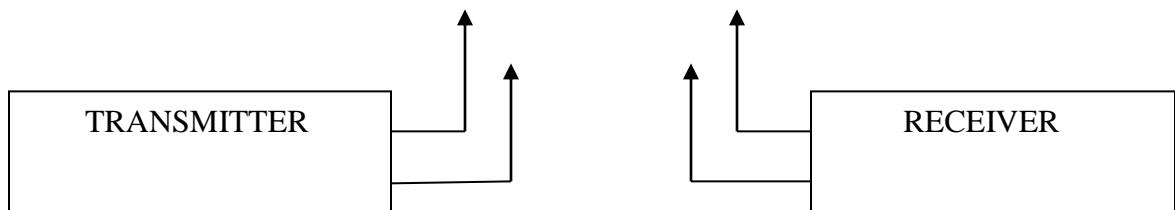

Fig.3.5. Transmit-Receiver Space Diversity

3.4.3 Different Types of Combining Techniques For Space Diversity:

Combining of independently faded signal branches can be merged in a different ways in order to increase the received signal to noise ratio at destination. By employing combining schemes both the instantaneous and average signal to noise ratio at receiver can be improved. The improvement in average and instantaneous signal to noise ratio depends upon type of combining approach used. Since there are very less chance that all the uncorrelated branches have deep fade at any particular instant of time. Combining them altogether can reduce the effect of fading. Three major combining schemes used are: Selection Combining, Equal Gain Combining and Maximal Ratio Combining.

Space diversity reception methods can be classified into four categories [5]:

1. Selection diversity
2. Feedback diversity
3. Maximal ratio combining
4. Equal gain diversity

3.4.3.1 Selection Diversity

Selection diversity is the simplest diversity technique which is similar to shown in Figure 3.6, where m demodulators are used to provide m diversity branches whose gains are selected in such a way that to provide the same average SNR for each branch. The receiver branch having the highest instantaneous SNR is connected to the demodulator. The antenna signals themselves could be sampled and the best one sent to a single demodulator.

In practice, the branch with the largest SNR is used, but it is difficult to measure SNR alone. In practical selection diversity system cannot function on a truly instantaneous basis, but must be designed so that the internal time constants of the selection circuitry are shorter than the reciprocal of the signal fading rate

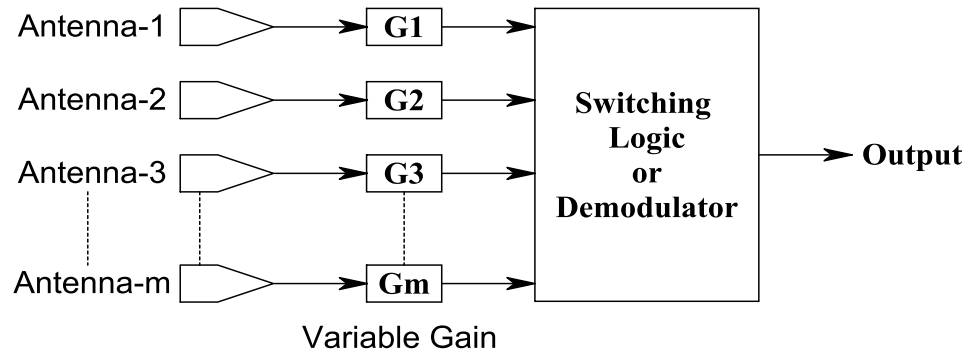

Figure 3.6. Generalize Diagram of Antenna Diversity.

3.4.3.2 Feedback or Scanning Diversity

In Scanning diversity, all M antenna signals are scanned in a particular sequence until signal strength get beyond the pre fixed threshold voltage. This signal is then received until it falls below threshold and the scanning process is again initiated as shown in Figure 3.7.

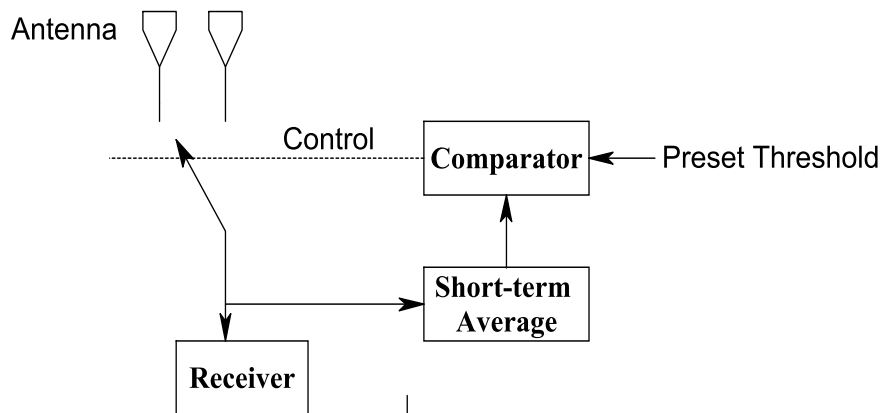

Fig. 3.7. Scanning Diversity

If all signals received at the receiver do not have the signal strength above the threshold then this technique will fail. But the advantage with this method is that it is very simple to implement where only one receiver is required.

3.4.3.3 Maximal Ratio Combining

In this method, the signals from all of the M branches are weighted according to their individual signal voltage to noise power ratios and then summed.

Figure 3.8 shows block diagram of the technique. Here, the individual signals must be received before being summed (unlike selection diversity) which generally requires an individual receiver and phasing circuit for each antenna element.

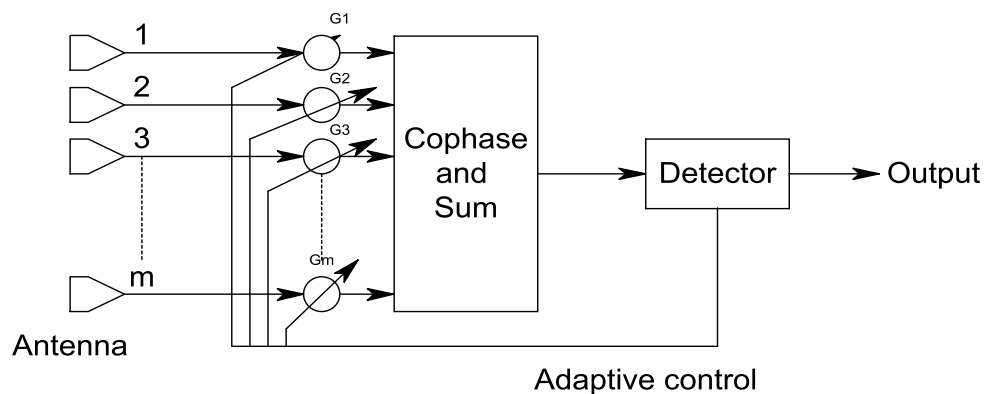

Fig. 3.8. Maximum ratio combiner.

Maximal ratio combining produces an output SNR equal to the sum of the individual SNRs. Thus it has the advantage of producing an output with an acceptable SNR even when none of the individual signals are themselves acceptable. This technique gives the best statistical reduction of fading of any known linear diversity combiner, but required more no. of receivers.

3.4.3.4 Equal Gain Combining

In certain cases, it is not possible to provide for the variable weighting capability required for true maximal ratio combining. In such cases, the branch weights are all set to unity, but the signal from each branch are co-phased to provide equal gain combining diversity. This allows the receiver to exploit Signals that are simultaneously received on each branch. The possibility of producing an acceptable signal from a number of unacceptable

inputs is still retained, and performance is only marginally inferior to maximal ratio combining and superior to selection diversity.

3.5 Fading Models or Distribution

3.5.1 Rayleigh Distribution

Rayleigh Distribution is historically commonly used to describe the statistical time varying nature of received signal, if there is no line of sight.

The Rayleigh distribution is a time function describe the magnitude of the sum of two equal independent orthogonal Gaussian random variables and the *probability density function* (PDF) is given in by

$$p(r) = \frac{r}{\sigma^2} e^{-\frac{r^2}{2\sigma^2}} \quad 0 \leq r \leq \infty \quad (3.1)$$

where σ is the rms value of the received voltage signal before envelope detected and σ^2 is the time-average power of the received signal [1].

3.5.2 Ricean Distribution

When there is line of sight, direct path is normally the strongest component goes into deeper fade compared to the multipath components. This kind of signal is approximated by Ricean distribution. In such a situation, a stationary dominant signal will superimposed by random multipath components receiving at different angles.

As the dominating component run into more fade the signal characteristic goes from Ricean to Rayleigh distribution. The Ricean distribution is given by

$$p(r) = \frac{r}{\sigma^2} e^{-\frac{(r^2+A^2)}{2\sigma^2}} I_0 \frac{Ar}{\sigma^2} \quad \text{For } (A \geq 0, r \geq 0) \quad (3.2)$$

Where A denotes the peak amplitude of the dominant signal, I_0 is the modified Bessel function of zero-order and the first kind [1].

3.5.3 Gamma Distribution

The probability density function (PDF) of the gamma distribution can be expressed in terms of the gamma function parameterized in terms of a shape parameter k and scale parameter θ . Both k and θ are always positive values.

The PDF of a gamma- distribution for random variable X is given as

$$f_x(x) = \frac{\left(\frac{x}{\theta}\right)^{k-1} \exp\left(-\frac{x}{\theta}\right)}{\theta(k)} u(x) \quad \text{For } k, \theta > 0 \quad (3.3)$$

Its cumulative distribution function (CDF) given by

$$F_x(x) = \frac{p(k, x/\theta)}{(k)} u(x) \quad (3.4)$$

In the above equations, the gamma function is a generalization of the factorial function defined by

$$\Gamma(a) = \int_0^{\infty} e^{-t} t^{a-1} dt \quad (3.5)$$

And the incomplete gamma function is given by

$$P(\alpha, \beta) = \int_0^{\beta} e^{-t} t^{\alpha-1} dt \quad (3.6)$$

3.5.4 Nakagami-m Distribution

The Nakagami distribution or the Nakagami- m distribution is a probability distribution related to the gamma distribution. It has two parameters: one is shape parameter ‘ μ ’ and second parameter is controlling spread, ‘ ω ’.

The Nakagami- m distribution having the PDF of the form

$$f(x, \mu, \omega) = \frac{2\mu^\mu}{\Gamma(\mu)\omega^\mu} x^{2\mu-1} e^{-\frac{\mu}{\omega}x^2} \quad \text{for } 0 \leq x < 1 \quad (3.7)$$

Its CDF is given by

$$F(x, \mu, \omega) = P\left(\mu, \frac{\mu}{\omega}, X^2\right) \quad F(x, \mu, \omega) = P\left(\mu, \frac{\mu}{\omega}, X^2\right) \quad (3.8)$$

Where P is the incomplete gamma function

In addition to the m-distribution, the following compact form of distribution is presented by Nakagami (1940) and is named *n-distribution* [2]

$$P(R) = \frac{2R}{\sigma} e^{-\left(\frac{R^2 + R_0^2}{\sigma}\right)} I_0\left(\frac{2RR_0}{\sigma}\right) \quad (3.9)$$

and

$$P(R) = \frac{2R}{\alpha\beta} e^{-\left(\frac{R^2}{2}\right)\left(\frac{1}{\beta} + \frac{1}{\alpha}\right)} I_0\left(\frac{R^2}{2}\left(\frac{1}{\beta} - \frac{1}{\alpha}\right)\right) \quad (3.10)$$

is called q-distribution.

ORTHOGONAL FREQUENCY DIVISION MULTIPLEXING

This chapter describes mathematical analysis of OFDM system. It elaborates the OFDM block diagram with its transmitter, channel and receiver. Simulation results are done to evaluate the performance of OFDM system over multipath environment with inserting cyclic prefix and without inserting cyclic prefix by using different modulation schemes and different subcarriers. At last, the simulation results and conclusion of the chapter are discussed.

4.1 OFDM System Model

The discrete time baseband OFDM system with N subcarriers is shown in figure 4.1. It consists of transmitter, channel and receiver blocks.

4.1.1 Transmitter

In this model, a block of input bits (symbols) are modulated by M-ary data modulators and then N such symbols are transferred by the serial to parallel converter. Different types of data modulator can be used depending upon system requirement (e.g. M-PSK, M-QAM etc.). The complex parallel data symbols (X_k) obtained by using modulation techniques are given to N point IFFT block as shown in figure 4.1.

The complex envelope of the baseband transmitted OFDM signal can be written as-

$$x(t) = \frac{1}{\sqrt{N}} \sum_{k=0}^{N-1} X_k e^{j2\pi f_k t}, \quad 0 \leq t \leq NT \quad (4.1)$$

where, N is the total number of subcarriers, X_k , $k = (0, 1, \dots, N - 1)$ block of N input bits (symbols), $f_k = k\Delta f$, where $\Delta f = \frac{1}{NT}$, T =original symbol period. Generally, the

complex data are uncorrelated as shown in below-

$$E[X_k X_l^*] = \begin{cases} 1, & k = l \\ 0 & k \neq l \end{cases} \quad (4.2)$$

where, X_l^* represents the complex conjugate of X_l .

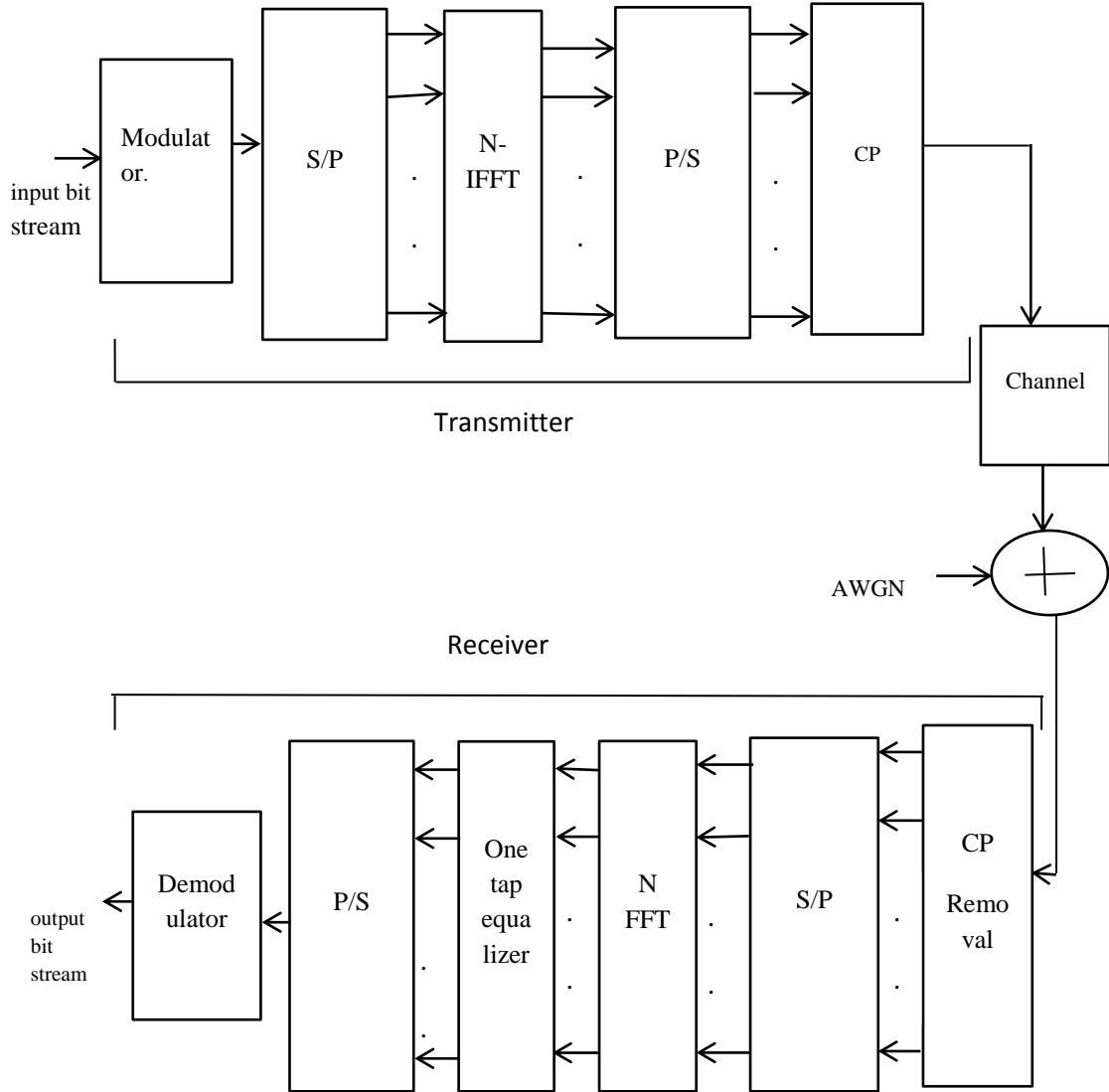

Figure.4.1. Block diagram of OFDM system

The discrete form of OFDM signal $x(n)$ is given by-

$$x(n) = \frac{1}{\sqrt{N}} \sum_{k=0}^{N-1} X_k e^{j2\pi kn/N}, \text{ for } n = 0, 1, 2, 3 \dots N-1 \quad (4.3)$$

equation (4.3) shows that transmitted signal $x(n)$ is obtained by taking the inverse discrete Fourier transform (IDFT) of modulated input data symbols X_k . As shown in figure 4.1, practically IDFT can be comfortably and thoroughly obtained by using inverse fast Fourier transform (IFFT) [6].

4.1.1.1 Addition of Guard Band

Guard interval in OFDM system is used to remove ISI which is generally introduced between consecutive OFDM symbols. The delay spread of multipath channel caused ISI in OFDM symbols. To remove ISI entirely a guard band interval with no signal transmission can be used but it can produce ICI because of higher spectral components which occurred due to quickly change of waveform.

The guard interval can be used in two ways- zero padding (ZP) and cyclic extension. Cyclic extension can be extended in two ways- cyclic prefix (CP) or cyclic suffix (CS).

4.1.1.2 Cyclic Prefix

In cyclic prefix, small part or portion of transmitted symbols are taken and repeat that small portion as the prefix of transmitted symbol [8].

By prefixing of OFDM symbol ISI is removed. The CP insertion is shown in figure 4.2.

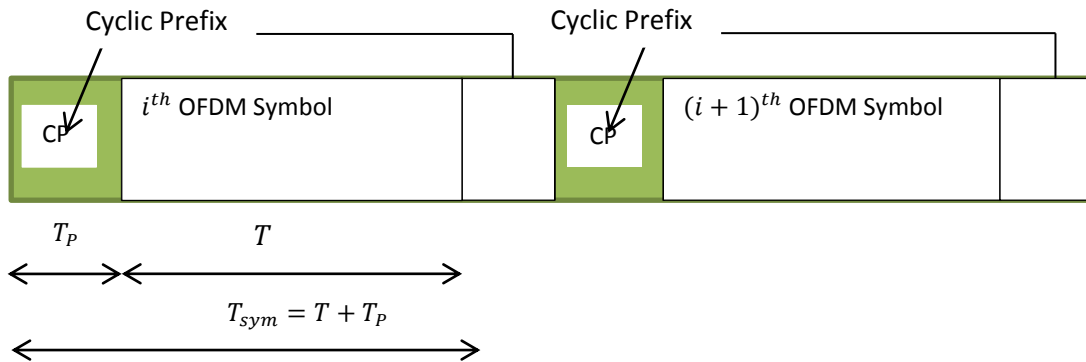

Figure 4.2. OFDM symbols with cyclic prefix

Addition of cyclic prefix extends OFDM symbols to $T_{sym} = T + T_p$ and mathematically it can be expressed as-

$$x(t)_{ext} = \frac{1}{\sqrt{N}} \sum_{k=0}^{N-1} X_k e^{j2\pi f_k t}, \quad -T_P \leq t \leq T \quad (4.4)$$

where, $x(t)_{ext} = x(t+T)$, for $-T_P \leq t \leq 0$.

The discrete form of the prefixed OFDM symbols can be expressed as-

$$x(n)_{ext} = \begin{cases} x(n+N), & \text{for } n=0,1,\dots,P-1 \\ \frac{1}{\sqrt{N}} \sum_{k=0}^{N-1} X_k e^{j2\pi k(n-P)/N}, & \text{for } n=P,P+1\dots P+N-1 \end{cases} \quad (4.5)$$

where, N is the total number of sub-carriers and P is total number of CP symbols added in the OFDM symbol.

The length of the CP should be greater than delay spread of a multipath channel. If the CP is less than delay spread of multipath channel then the head part of the next OFDM symbol will be altered by the tail part of previous OFDM symbol, leading to ISI. The cyclic prefix larger than the delay spread of the multipath channel maintains the orthogonality among the subcarriers.

4.1.1.3 Cyclic Suffix

In cyclic suffix, small part or portion of transmitted symbols are taken and repeat that small portion as the suffix of transmitted symbol as shown in figure 4.3.

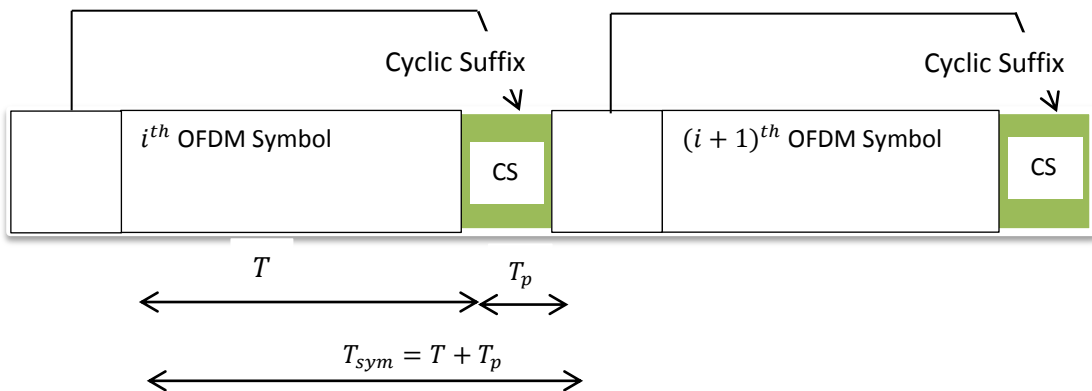

Figure 4.3. OFDM symbols with cyclic suffix

It copy upper portion of OFDM symbol to the bottom of the symbol to mitigate inter symbol interference (ISI). This method of insertion of guard interval is used for frequency hopping and radio frequency (RF) convergence.

4.1.1.4 Zero Padding

In zero padding (ZP) top and bottom portion of the transmitted symbols are filled with zeros as shown in figure 4.4.

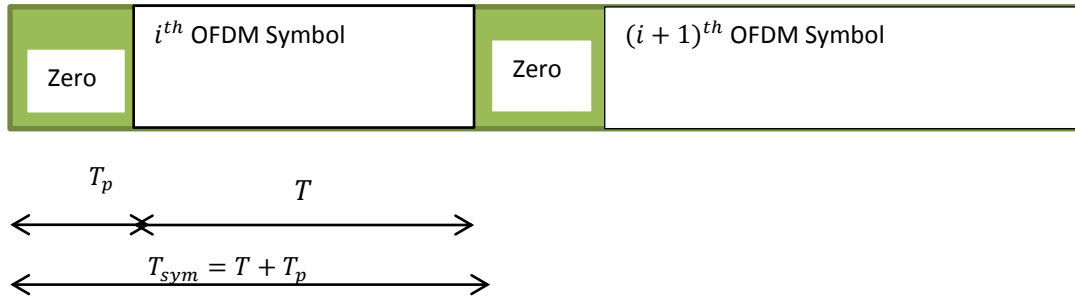

Figure 4.4. OFDM symbols with zero padding

4.1.2 Channel Model

The phenomenon of noise and multipath environment can be predicted by using channel model. Generation of noise can be done by adding few random data to the OFDM symbol and multipath environment can be generated by adding attenuated and delayed copies of the OFDM signal. The impulse response $h(\Gamma - t)$ for wireless channel is given by as [5]

$$h(\Gamma - t) = \sum_{l=0}^{L-1} h_l(t) \delta(t - \Gamma) \quad (4.6)$$

where, $h_l(t)$ and Γ are the tap coefficient or complex amplitude and propagation delay.

The tap coefficient $h_l(t)$, $l=0,1,2,\dots,L-1$ are modelled as zero mean complex Gaussian random variables having variance 1. Rayleigh fading model provide a suitable environment on a wireless signal [5]. The amplitude of wireless signal follows the

Rayleigh distribution because of multipath environment and its probability density function (pdf) is given as [1]-

$$f(r) = \frac{r}{\sigma^2} \exp\left\{-\frac{r^2}{2\sigma^2}\right\}, \quad r \geq 0 \quad (4.7)$$

where, r is envelope of received signal and σ^2 is a variance of envelope of received signal. In Rayleigh distribution, propagation of signal is along non line of sight (NLOS) between the transmitter and receiver.

After multipath fading channel $h(\Gamma, t)$, the received signal $y(t)$ is expressed

$$y(t) = \sum_{l=0}^{L-1} h_l(t) x_{ext}(t - \Gamma) + n(t) \quad (4.8)$$

where, $n(t)$ is the Additive White Gaussian Noise (AWGN) [5].

4.1.3 Receiver

At the receiver, inverse of the transmitter is done. Here, first the guard interval of OFDM symbol is removed. Then these unguarded OFDM symbol is converted from serial to parallel which are passed through FFT block. The FFT converts these parallel OFDM data streams into frequency domain. The output of FFT operation can be expressed as-

$$X(k) = F(k)x(k) + w(k), \text{ for } 0 \leq k \leq N-1 \quad (4.9)$$

where, $w(k)$ is the AWGN component in frequency domain and $F(k)$ denotes the FFT (frequency response of the multipath fading channel at the k sub channel) which is expressed as

$$F(k) = \frac{1}{\sqrt{N}} \sum_{l=0}^{L-1} h_l e^{-\frac{j2\pi kn}{N}}, \quad k = 0, 1, \dots, N-1 \quad (4.10)$$

The complex data received symbol $x(k)$ can be recovered by single tap frequency domain equalizer and expressed as-

$$G(K) = \frac{1}{F(k)} \quad (4.11)$$

The tap coefficients of the filter are calculated based on channel information [7].

Finally, the recovered data symbol are converted back into serial stream and demodulated by using scheme like (M-PSK, M-QAM) to baseband.

4.2 STBC-OFDM

Space-time block coded Orthogonal-Frequency-Division Multiplexing (STBC-OFDM) system is an advanced modulation technique which used in the emerging broadband fourth generation wireless communication systems and high-definition-television (HDTV) broadcasting [12], because of its high spectral efficiency and inherent robustness to the channel impairments. In the conventional approaches, the single carrier systems are forced to invert the channel characteristics, a problem that is provoked by the multipath dynamics and packet waveform formats [11]. However, the major benefit that the OFDM offers over single carrier approaches is the resistance to the multipath fading, diversity schemes for better SNR, the STBCs have appeared as a breakthrough in the field of high data transmission rate wireless communication systems. The pioneering work of Alamouti is based on the two transmitter antennas, which exploits the spatial diversity to improve the SNR without bandwidth expansion. However, the perfect knowledge of the mutually uncorrelated Rayleigh fading channels or channel state information (CSI) is assumed to be available at the receiver. Under these conditions, the OFDM technology is merged with STBC system to achieve the benefit of both schemes [10]. A simple and efficient receiver structure may be used for STBC-OFDM systems, which do not require CSI [11].

As shown in STBC-OFDM block diagram

Two signals are transmitted simultaneously from two antennas at a known symbol period. From antenna one transmitted signal is denoted by X_1 and from antenna two transmitted signal is denoted by X_2 . In next symbol period, antenna one will transmit signal $(-X_2^*)$ and antenna two will transmit signal X_1^* where $(*)$ is the complex conjugate operator and this process is repeated for further transmission of other symbols.

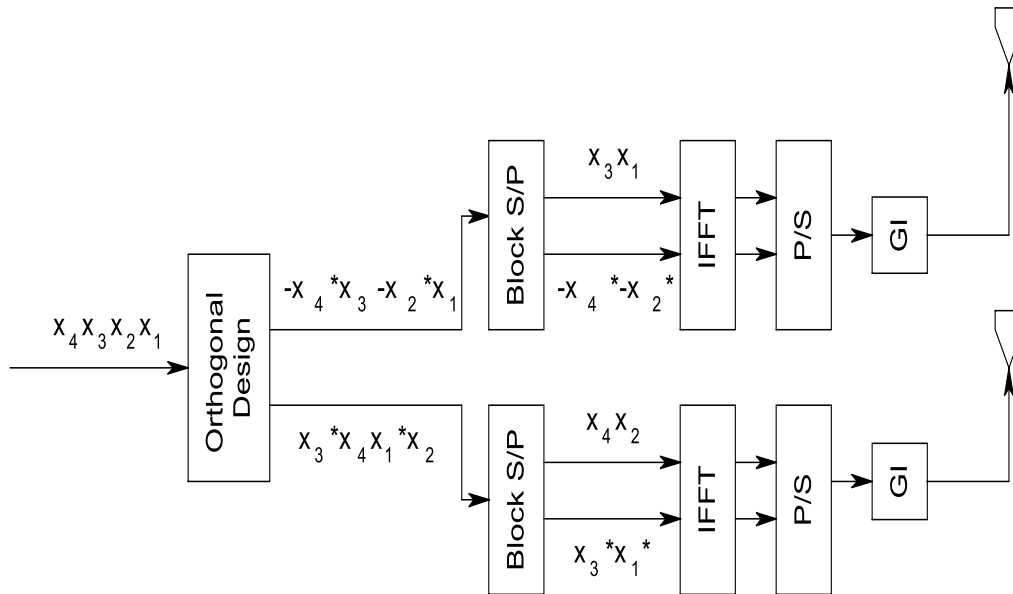

Figure 4.5. Time domain implementation of STBC-OFDM system

4.3 Simulation Results

4.3.1 Comparison of STBC With EGC And MRRC

Fig. 4.6 Compares the performance of STBC with equal gain combining and maximal ratio receiver combining scheme (MRRC). In the simulations, we assumed that the channel gain is perfectly known at the receiver, estimation is done using classical ZF. The effects of channel estimation on our performance comparisons are not addressed here and are a subject for future research. It has been shown that an STBC with MRRC scheme achieves better performance than STBC with equal gain combining scheme.

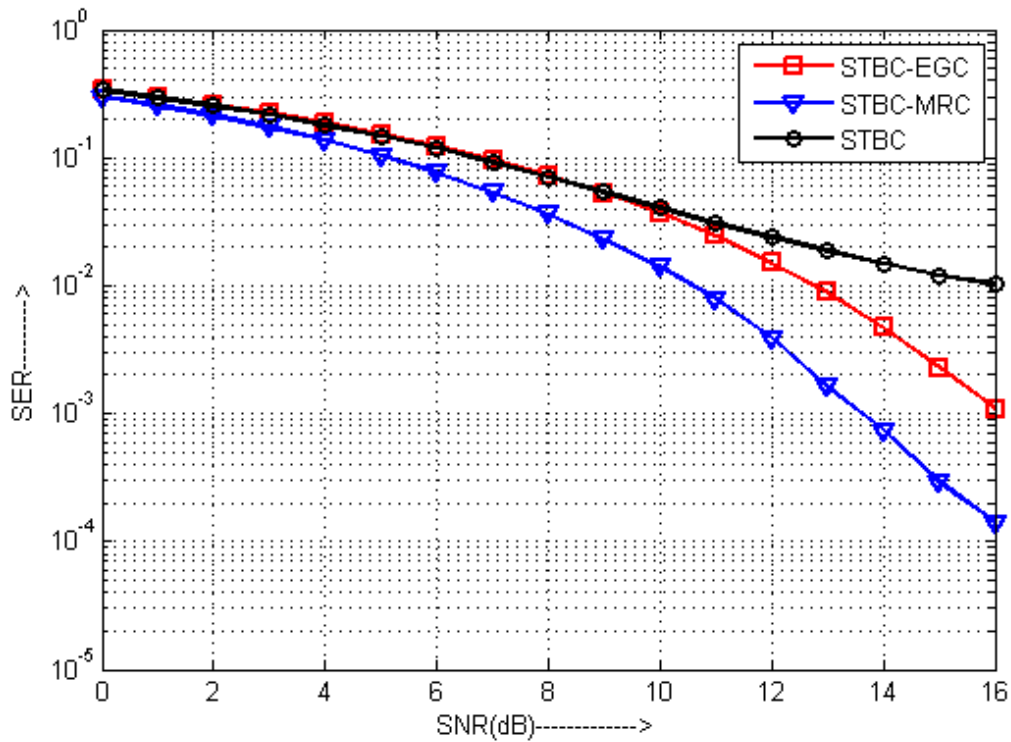

Fig. 4.6. BER Performance of STBC system with EGC and MRC schemes.

4.3.2 Comparison of STBC-OFDM For $m=0.75, 1, 1.25$

For $m=1$, Nakagami- m fading channel gives similar performance as Rayleigh fading channel or in other words Rayleigh is a special case of Nakagami- m fading for $m=1$. When coherence time is smaller than the symbol duration of signal ($T_S > T_C$), Fast fading occurs and this case refers to $m < 1$ and such types of channel becomes time varying because within a symbol duration rapid changes occurs in impulse response of the channel. In STBC system an assumption is taken that channel frequency response remains same for two consecutive symbols, practically it is not the case for $m < 1$. Hence performance of STBC-OFDM degrades for $m < 1$ as compared to $m \geq 1$ which is clearly shown in Fig 4.7.

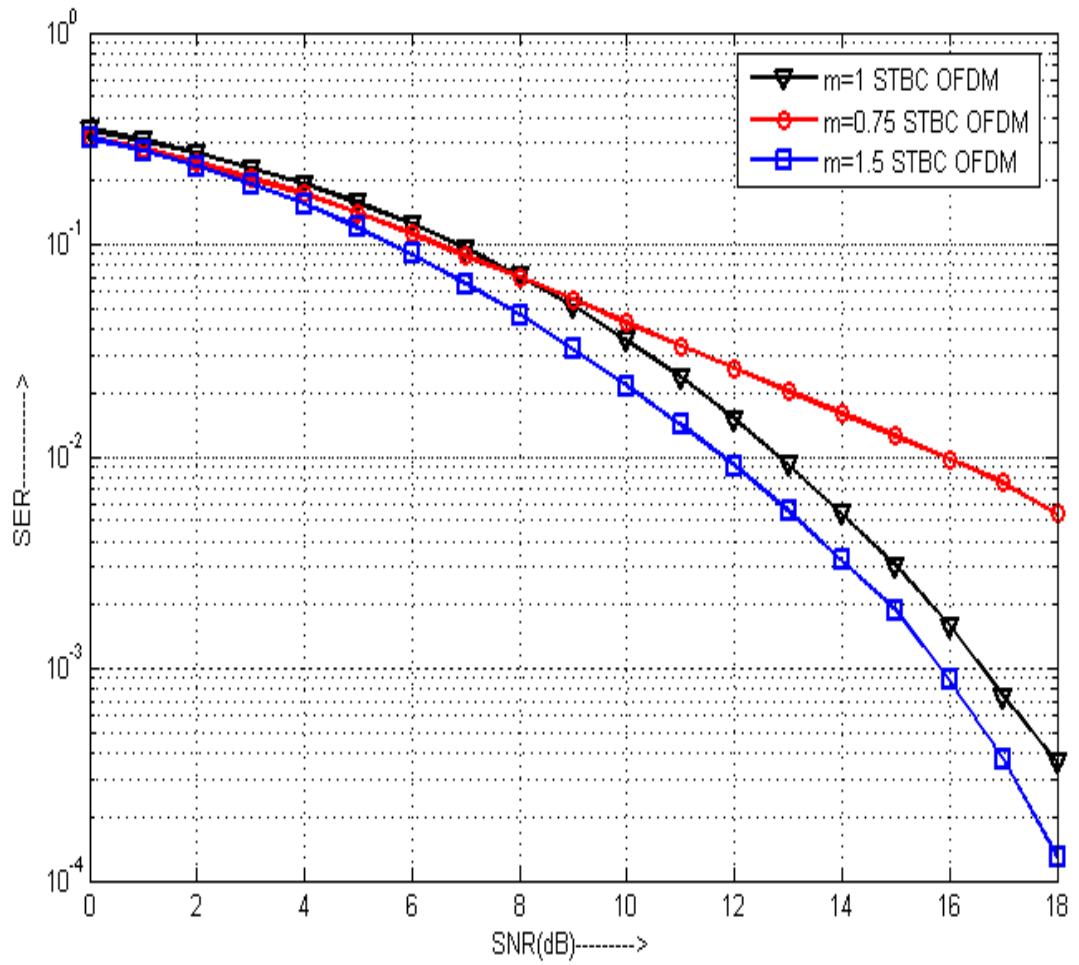

Fig.4.7. SER Performance of STBC-OFDM in m-Nakagami fading environment.

SPACE TIME BLOCK CODE

Space time block coding is a technique used in wireless communications to transmit multiple copies of a data stream across a number of antennas and to exploit the various received versions of the data to improve the reliability of data-transfer. The fact that the transmitted signal must traverse a potentially difficult environment with scattering, reflection, refraction and so on and may then be further corrupted by thermal noise in the receiver means that some of the received copies of the data will be better than others. This redundancy results in a higher chance of being able to use one or more of the received copies to correctly decode the received signal. Space-time coding combines all the copies of the received signal in an optimal way to extract as much information from each of them as possible.

5.1 Two Branch Transmit Diversity

This scheme uses two transmit antennas and one receive antenna and can be explained by the following three functions [4]:

- Encoding and transmission sequence of information symbols at the transmitter
- Combining scheme at the receiver
- Decision rule for maximum likelihood detection.

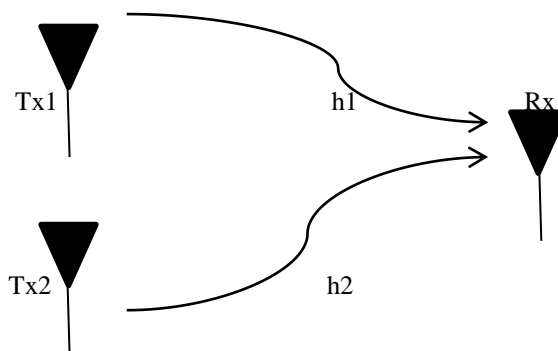

Fig.5.1. Two branch transmit diversity scheme.

5.1.1 Encoding and Transmission Sequence

Two signals are transmitted simultaneously from two antennas at a known symbol period. From antenna one transmitted signal is denoted by x_1 and from antenna two transmitted signal is denoted by x_2 . In next symbol period, antenna one will transmit signal $(-x_2^*)$ and antenna two will transmit signal x_1^* where (*) is the complex conjugate operator. This sequence is shown in table .

The Encoding and transmission sequence for two-branch transmit diversity scheme

	<i>Antenna 1</i>	<i>Antenna 2</i>
T	x_1	x_2
$t+ T$	$-x_2^*$	x_1^*

In above table , encoding is done in space and time both domains (space-time coding). Encoding can be done in space and frequency. In place of two adjacent symbol periods, two adjacent carriers may be used (space-frequency coding) [4].

The channel at time T can be modeled by a complex multiplicative distortion $h_1(t)$ for transmission from antenna one and $h_2(t)$ for transmission from antenna two. By taking an assumption that fading is constant for two consecutive symbols, we can write

$$h_1(t) = h_1(t+T) = h_1 \quad (5.1)$$

$$h_2(t) = h_2(t+T) = h_2 \quad (5.2)$$

Where T is symbol duration. Therefore received signal is expressed as follows:

$$r_1 = r(t) = h_1 x_1 + h_2 x_2 + n_1 \quad (5.3)$$

$$r_2 = r(t+T) = -h_1 x_2^* + h_2 x_1^* + n_2 \quad (5.4)$$

$$r_2^* = r^*(t+T) = -h_1^* x_2 + h_2^* x_1 + n_2^* \quad (5.5)$$

We can also write above equations in matrix representation as:

$$\begin{aligned}
\mathbf{R} &= \begin{bmatrix} r_1 \\ * \\ r_2 \end{bmatrix} \\
&= \begin{bmatrix} h_1 & h_2 \\ h_2^* & -h_1^* \end{bmatrix} \begin{bmatrix} x_1 \\ x_2 \end{bmatrix} + \begin{bmatrix} n_1 \\ * \\ n_2 \end{bmatrix} \\
&= \mathbf{H}\mathbf{X} + \mathbf{n}
\end{aligned} \tag{5.6}$$

By Linear combiner equalizer like zero forcing we can estimate the symbols given below

$$\begin{aligned}
\hat{\mathbf{R}} &= \mathbf{H}^H \mathbf{R} \\
\hat{\mathbf{x}} &= (\mathbf{H}^H \mathbf{H})^{-1} \mathbf{H}^H \mathbf{R}
\end{aligned}$$

5.2 High-Rate STBC

In high rate ($rate = \frac{5}{4}$) full diversity orthogonal STBC for QAM and 2 transmit antennas(Tx) by expanding the signalling set from the set of quaternions used in Alamouti [4] code. To maximizing full-diversity, selective power scaling of information symbols is used while maximizing the coding gain (CG) and minimizing the transmitted signal peak to minimum power ratio (PMPR). Analytically we derive optimum power scaling factor and we see that it achieves better performance with the help of rotation of constellation points, decoding is performed using low complexity maximum likelihood decoding algorithm[12].

After studying the literature we came to know that in [13] They have designed high rate STBC system, by not considering loss of ‘quasi-static’ assumption due to frequency selectivity phenomenon of channel. Due to frequency selectivity of channel causes ISI which results in error floor in bit error rate. First I describe the high rate STBC system for frequency flat case, Secondly, To compact the effect of ISI in frequency selective environment, I proposed low complexity zero forcing which reduces the complexity of equalizer.

5.2.1 System Model of High-Rate STBC

The simplest complex orthogonal design is the 2×2 code

$$G_1(x_1, x_2) \rightarrow \begin{pmatrix} x_1 & x_2 \\ * & * \\ -x_2 & x_1 \end{pmatrix}$$

find out by Alamouti [4] where $(.)^*$ denotes the complex conjugate transpose. This code accomplishes rate-1 at full diversity. The correspondence between Alamouti matrices and means of quaternion's is that the set of Alamouti matrices is closed under inversion, addition and multiplication. Consider the set G_2 of \mathbf{x} given by 2×2 orthogonal matrices

$$G_2(x_1, x_2) \rightarrow \begin{pmatrix} x_1 & x_2 \\ * & * \\ x_2 & -x_1 \end{pmatrix} = \begin{pmatrix} 1 & 0 \\ 0 & -1 \end{pmatrix} G_1$$

5.2.2 Transmission Model

Different antennas represented by the columns of G_1 , different time slots represented by rows of G_1 and two symbols are transmitted in frequency selective fading environment. We use *QAM* modulation in this system, the transmission of space-time matrix is done based on either G_1 or G_2 according to an extra information bit of 1 or 0 respectively shown in Fig.5.2. To regain full-diversity, Strategy based on rotation of information symbols has been proposed. In this paper, we assume the information symbol in G_2 is divided only by a real scalar $K(>1)$ to ensure full-diversity, hence it is called selective power scaling. For QAM constellation of unit-radius, scaling leads to overall signal constellation consisting of two concentric circles of radius 1 and $\frac{1}{k}$ [28]. For the optimum power scaling factor k is to ensure full diversity for high-rate STBC. As $k > 1$, the average transmitted power is reduced as compared to the case of no scaling. Two important selection techniques for k are maximizing the CG and minimizing the PMPR due to power scaling. We select $k_{opt} = \sqrt{3}$ which is proposed in [13].

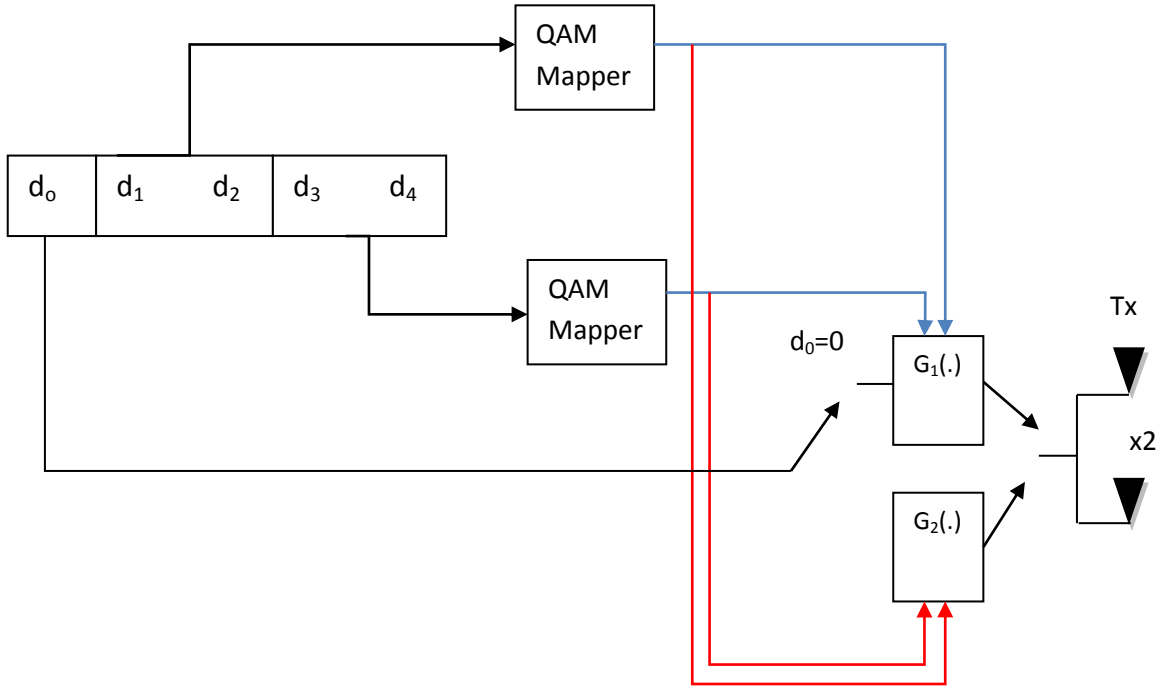

Fig. 5.2. Block diagram of rate-5/4 STBC for QAM Modulation

5.2.3 Received Signal Model of High-Rate STBC:

Time domain representation of received signal at receiver is denoted by

$$\begin{bmatrix} r_{1,t} \\ r_{1,t+1} \end{bmatrix} = \begin{bmatrix} h_{1,t} & h_{2,t} \\ h_{2,t+1}^* & -h_{1,t+1}^* \end{bmatrix} \begin{bmatrix} x_1 \\ x_2 \end{bmatrix} + \begin{bmatrix} n_t \\ n_{t+1} \end{bmatrix} \quad (5.7)$$

$$\underbrace{\quad} \quad \underbrace{\quad} \quad \underbrace{\quad} \quad \underbrace{\quad}$$

$$\mathbf{R} \quad \mathbf{H} \quad \mathbf{X} \quad \mathbf{N}'$$

$$\begin{bmatrix} r_{1,t}^{opt} \\ r_{1,t+1}^{opt} \end{bmatrix} = \begin{bmatrix} \frac{h_{1,t}}{K} & \frac{-h_{2,t}}{K} \\ \frac{h_{2,t+1}^*}{K} & \frac{h_{1,t+1}^*}{K} \end{bmatrix} \begin{bmatrix} x_1 \\ x_2 \end{bmatrix} + \begin{bmatrix} n_t \\ n_{t+1} \end{bmatrix} \quad (5.8)$$

$$\underbrace{\quad} \quad \underbrace{\quad} \quad \underbrace{\quad} \quad \underbrace{\quad}$$

$$\mathbf{R}_{opt} \quad \mathbf{H}_{opt} \quad \mathbf{X} \quad \mathbf{N}'$$

Where \mathbf{R} and \mathbf{R}_{opt} are 2×2 matrix representations of the time domain received signals corresponding to transmitted code words in the form of G_1 and G_2 , respectively. $h_{i,t}, i = 1, 2$ is channel path gain from transmitter 1 and transmitter 2, respectively at t time instant.

5.2.3.1 For Frequency Flat Condition :

Due to frequency flat nature of channel we can say that $h_{1,t} = h_{1,t+1}$ and $h_{2,t} = h_{2,t+1}$.

Therefore received signal is represented from eq.(1) is

$$\begin{bmatrix} r_{1,t} \\ r_{1,t+1} \end{bmatrix} = \begin{bmatrix} h_{1,t} & h_{2,t} \\ h_{2,t}^* & -h_{1,t}^* \end{bmatrix} \begin{bmatrix} x_1 \\ x_2 \end{bmatrix} + \begin{bmatrix} n_t \\ n_{t+1} \end{bmatrix} \quad (5.9)$$

$$\mathbf{R} = \mathbf{H}\mathbf{X} + \mathbf{N}'$$

$$\hat{\mathbf{R}} = \mathbf{H}^H (\mathbf{H}\mathbf{X} + \mathbf{N}') \quad (5.10)$$

Where

$$\mathbf{H}^H \mathbf{H} = \begin{bmatrix} |h_{1,t}|^2 + |h_{2,t}|^2 & 0 \\ 0 & |h_{1,t}|^2 + |h_{2,t}|^2 \end{bmatrix},$$

here off diagonal element of $\mathbf{H}^H \mathbf{H}$ is zero so there is no inter symbol interference.

Similarly from eq.(2)

$$\begin{bmatrix} r_{1,t}^{opt} \\ r_{1,t+1}^{opt} \end{bmatrix} = \begin{bmatrix} \frac{h_{1,t}}{K} & \frac{-h_{2,t}}{K} \\ \frac{h_{2,t}^*}{K} & \frac{h_{1,t}^*}{K} \end{bmatrix} \begin{bmatrix} x_1 \\ x_2 \end{bmatrix} + \begin{bmatrix} n_t \\ n_{t+1} \end{bmatrix} \quad (5.11)$$

$$\mathbf{R}_{opt} = \mathbf{H}_{opt} \mathbf{X} + \mathbf{N}'$$

$$\hat{\mathbf{R}}_{opt} = \mathbf{H}_{opt}^H (\mathbf{H}_{opt} \mathbf{X} + \mathbf{N}') \quad (5.12)$$

Where
$$H_{opt}^H H_{opt} = \begin{bmatrix} \frac{1}{K^2} (|h_{1,t}|^2 + |h_{2,t}|^2) & 0 \\ 0 & \frac{1}{K^2} (|h_{1,t}|^2 + |h_{2,t}|^2) \end{bmatrix},$$
 here off diagonal

element of $\mathbf{H}_{opt}^H \mathbf{H}$ is zero so there is no inter symbol interference.

5.3 Proposed Low Complexity ZF Receiver:

Due to frequency selectivity nature of channel, there is loss of quasi-static assumption caused ISI. We can say that $h_{1,t} \neq h_{1,t+1}$ and $h_{2,t} \neq h_{2,t+1}$. Therefore received signal is represented from eq(1) is

$$\begin{bmatrix} r_{1,t} \\ r_{1,t+1} \end{bmatrix} = \begin{bmatrix} h_{1,t} & h_{2,t} \\ h_{2,t+1}^* & -h_{1,t+1}^* \end{bmatrix} \begin{bmatrix} x_1 \\ x_2 \end{bmatrix} + \begin{bmatrix} n_t \\ n_{t+1} \end{bmatrix}$$

$$\mathbf{R} = \mathbf{H}\mathbf{X} + \mathbf{N}'$$

$$\hat{\mathbf{R}} = \mathbf{H}^H (\mathbf{H}\mathbf{X} + \mathbf{N}')$$

Where
$$H^H H = \begin{bmatrix} |h_{1,t}|^2 + |h_{2,t}|^2 & \epsilon_1 \\ \epsilon_2 & |h_{1,t}|^2 + |h_{2,t}|^2 \end{bmatrix}, \quad \epsilon_1 = h_{1,t}^* h_{2,t} - h_{2,t+1} h_{1,t+1}^* \text{ and}$$

$\epsilon_2 = h_{2,t}^* h_{1,t} - h_{1,t+1} h_{2,t+1}^*$. Here off diagonal element of $\mathbf{H}^H \mathbf{H}$ is not zero so there is inter symbol interference due to loss of quasi-static assumption. To mitigate the effect of ISI we proposed Low Complexity Zero forcing (LZF).

$$\hat{\mathbf{R}} = \mathbf{H}^{LZF} (\mathbf{H}\mathbf{X} + \mathbf{N}') \tag{5.13}$$

$$\hat{\mathbf{X}} = (\mathbf{H}^{LZF} \mathbf{H})^{-1} \hat{\mathbf{R}} \tag{5.14}$$

$$\text{Where } H^{LZF} = \begin{bmatrix} h_{1,t}^* & \frac{h_{2,t+1}}{L_t} \\ h_{2,t}^* & -\frac{h_{1,t+1}}{L_t^*} \end{bmatrix} \text{ and } L_t = \frac{h_{2,t+1} \cdot h_{1,t+1}^*}{h_{1,t}^* \cdot h_{2,t}}$$

$$H^{LZF} H = \begin{bmatrix} |h_{1,t}^*|^2 + \frac{|h_{2,t+1}|^2}{L_t} & 0 \\ 0 & |h_{2,t}|^2 + \frac{|h_{1,t+1}|^2}{L_t^*} \end{bmatrix}$$

Similarly from eq.(2) is given by

$$\begin{bmatrix} r_{1,t}^{opt} \\ r_{1,t+1}^{opt} \end{bmatrix} = \begin{bmatrix} \frac{h_{1,t}}{K} & \frac{-h_{2,t}}{K} \\ \frac{h_{2,t+1}^*}{K} & \frac{h_{1,t+1}^*}{K} \end{bmatrix} \begin{bmatrix} x_1 \\ x_2 \end{bmatrix} + \begin{bmatrix} n_t \\ n_{t+1} \end{bmatrix}$$

$$\mathbf{R}_{opt} = \mathbf{H}_{opt} \mathbf{X} + \mathbf{N}'$$

$$\hat{\mathbf{R}}_{opt} = \mathbf{H}_{opt}^H \cdot (\mathbf{H}_{opt} \mathbf{X} + \mathbf{N}')$$

$$\text{Where } H_{opt}^H H_{opt} = \begin{bmatrix} \frac{1}{K^2} (|h_{1,t}|^2 + |h_{2,t+1}|^2) & \epsilon_1^{opt} \\ \epsilon_2^{opt} & \frac{1}{K^2} (|h_{1,t+1}|^2 + |h_{2,t}|^2) \end{bmatrix},$$

$$\epsilon_1^{opt} = \frac{-h_{1,t}^* h_{2,t}}{K^2} + \frac{h_{2,t+1} h_{1,t+1}^*}{K^2} \text{ and } \epsilon_2^{opt} = \frac{-h_{2,t} h_{1,t}}{K^2} + \frac{h_{1,t+1} h_{2,t+1}^*}{K^2}. \text{ Here off diagonal element}$$

of $\mathbf{H}_{opt}^H \mathbf{H}_{opt}$ is not zero so there is inter symbol interference due to loss of quasi-static assumption. To mitigate the effect of ISI we proposed Low Complexity Zero forcing (LZF).

$$\hat{\mathbf{R}}_{opt} = \mathbf{H}_{opt}^{LZF} \cdot (\mathbf{H}_{opt} \mathbf{X} + \mathbf{N}') \quad (5.15)$$

$$\hat{\mathbf{X}}_{opt} = (\mathbf{H}_{opt}^{LZF} \mathbf{H}_{opt})^{-1} \hat{\mathbf{R}}_{opt} \quad (5.16)$$

$$H_{opt}^{LZF} = \begin{bmatrix} \frac{h_{1,t}^*}{K} & \frac{h_{2,t+1}}{K \cdot L_t} \\ \frac{-h_{2,t}}{K} & \frac{h_{1,t+1}}{K \cdot L_t^*} \end{bmatrix} \text{ and } H_{opt}^{LZF} H_{opt} = \begin{bmatrix} \frac{1}{K^2} \left(|h_{1,t}|^2 + \frac{|h_{2,t+1}|^2}{L_{t,opt}} \right) & 0 \\ 0 & \frac{1}{K^2} \left(\frac{|h_{1,t+1}|^2}{L_{t,opt}^*} + |h_{2,t}|^2 \right) \end{bmatrix}$$

Applying Low complexity Zero forcing on eq.(5.8) and eq.(5.9) we generate two candidate solution namely, $\hat{\mathbf{X}}$ and $\hat{\mathbf{X}}_{opt}$ which are compared using $\left\| \mathbf{R}^T - [h_1 \ h_2] \mathbf{X}^T \right\|^2$ and $\left\| \mathbf{R}_{opt}^T - [h_1 \ h_2] \mathbf{X}_{opt}^T \right\|^2$. The decoding of d_o follows directly once the decision between $\hat{\mathbf{X}}$ and $\hat{\mathbf{X}}_{opt}$ is made.

SIMULATION RESULTS

6.1 SER Performance of High-Rate STBC and Alamouti STBC in Rayleigh Fading Channel

Performance of two transmits and one received antenna systems was investigated through MATLAB simulator. Considering a slow fading Rayleigh channel (i.e. frequency flat fading channel) model with QAM modulation for $N=64$ symbols to be transmitted. We assume that channel state information is known at the receiver. We compare high-rate STBC with the Alamouti STBC [4] using the measure of Effective Throughput. Fig. 6.1 shows that at high SNR, high-rate STBC achieves a higher throughput level of 2.5 bits per channel use (PCU) whereas Alamouti STBC achieves 2 bits PCU. We observe a cross-over point at an input SNR level of 16dB.

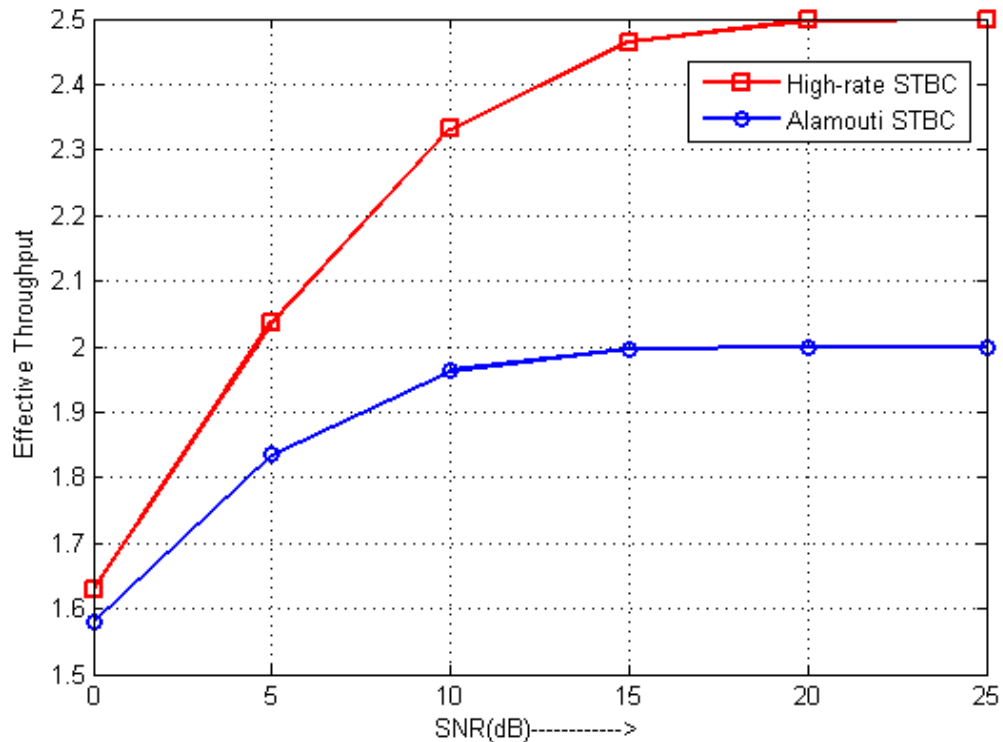

Fig. 6.1. Comparison of effective throughput: Alamouti STBC vs high-rate STBC for Rayleigh fading channel, $N=64$, QAM and 2 TX.

6.2 SER Performance of Alamouti STBC and High rate STBC in m -Nakagami Fading Channel For Frequency Flat Condition

Simulation results shown here are verified using MatLab v-7.5.0. The symbol error rate performance of two transmitter and one receiver antenna systems (high-rate STBC) was investigated through computer simulation. Considering m -Nakagami fading channel model with QAM modulation for the $N=64$ symbols to be transmitted. We assume that channel state information (CSI) is perfectly known at receiver.

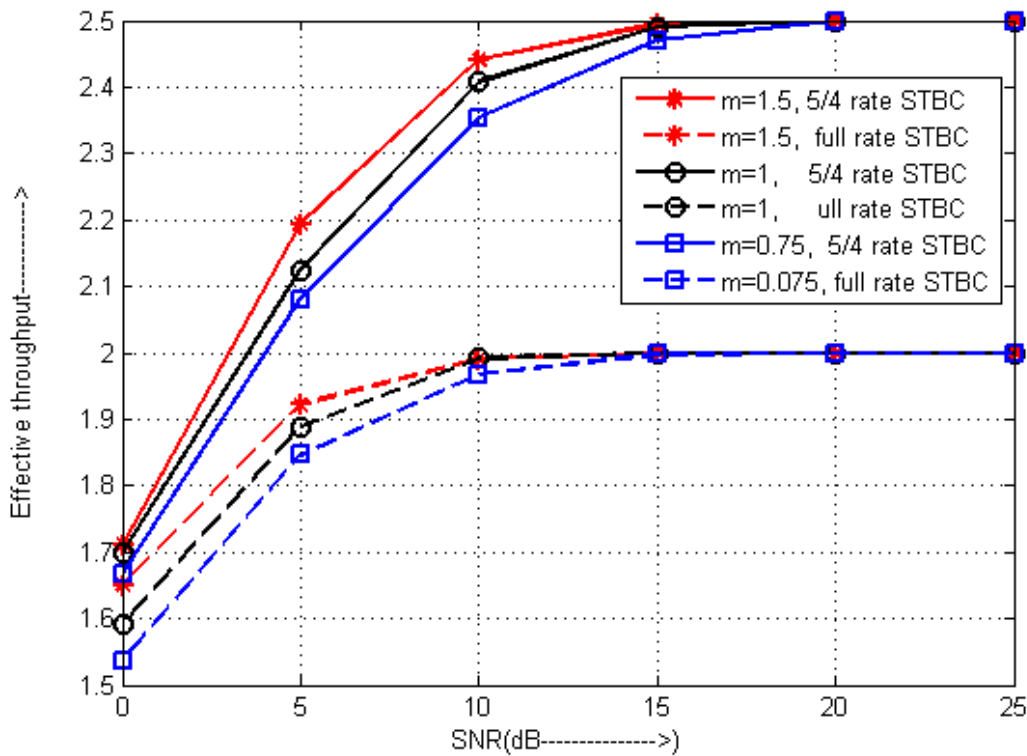

Fig. 6.2. Performance of Alamouti STBC and High rate STBC in m -Nakagami fading channel for frequency flat condition.

Rayleigh fading channel is special case of Nakagami- m fading channel when $m = 1$. Fast fading occurs if the coherence time is smaller than the symbol duration of the signal ($T_s > T_c$) this is the case when $m < 1$, such channels become time varying and within symbol duration rapid changes occur in impulse response of the channel, In STBC systems an assumption is made that channel impulse response remain same for two

consecutive symbol. Practically it is not the case for $m < 1$. Therefore performance of STBC or High rate STBC degrades for $m < 1$ as compared to $m \geq 1$.

Fig. 6.2 shows comparisons of High-rate STBC and Alamouti STBC for different values of m for frequency flat condition. We have seen that at lower value of SNR for $m > 1$ effective throughput is high in case of both high rate STBC as well as full rate STBC as compared to $m = 1$ and effective throughput is low for $m < 1$ compared to $m = 1$ for both systems. We also seen that effective throughput of High rate at high SNR is 2.5 becomes constant where as in full rate STBC get effective throughput 2 at high value of SNR.

6.3 SER Performance of Proposed Receiver For Alamouti STBC and High-Rate STBC in m -Nakagami Fading Channel For Frequency-Selective Condition.

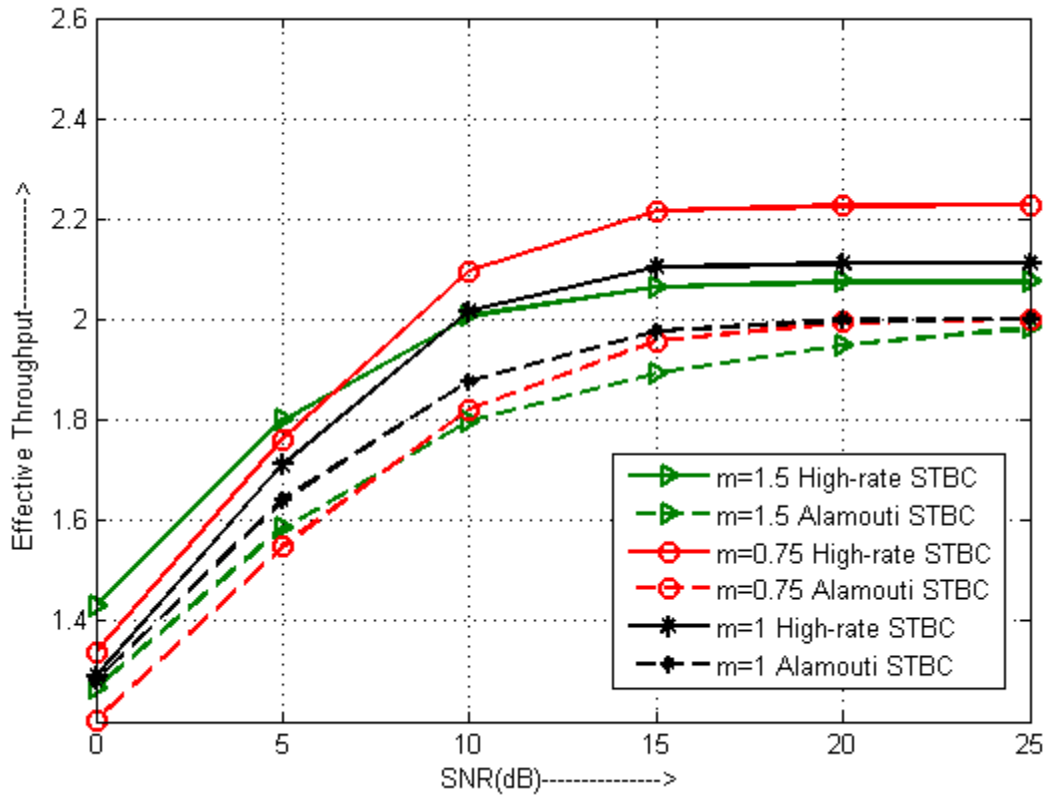

Fig. 6.3. Performance of proposed receiver for Alamouti STBC and High-rate STBC in m -Nakagami fading channel for frequency-selective condition.

Fig. 6.3. shows performance of proposed low complexity zero forcing for frequency selectivity of channel. At high values of SNR (e.g. 6dB to 20dB) proposed low complexity ZF receiver gives better effective throughput for the value of $m < 1$, for $m = 1$ effective throughput is between $m < 1$ and $m > 1$. Whereas at lower values of SNR (e.g. 0dB to 6dB) proposed receiver achieves better effective throughput for the value of $m > 1$.

With the help of proposed receiver at higher values of SNR full rate STBC achieves effective throughput like in case frequency flat condition by reducing complexity at receiver. For $m = 1$ full-rate STBC achieves better performance compared to $m < 1$ and $m > 1$.

CONCLUDING REMARKS AND FUTURE SCOPE

7.1 Concluding Remarks

Space-time coding for fading channels is a communication technique that realizes the diversity benefits of multipath transmit antennas. In this thesis, we exploited the algebraic structure of quaternions to design and optimize a high-rate, full-diversity STBC for 2 transmit antennas and one received antenna. We include the concept of selective power scaling to guarantee full-diversity for proposed code.

Simulation results in Fig. 4.7 show that for $m=1$, m -Nakagami fading channel gives similar performance as Rayleigh fading channel. When coherence time is smaller than the symbol duration of signal ($T_s > T_c$), the case of $m < 1$ refers to fast fading and such types of channel becomes time varying because within a symbol duration rapid changes occurs in impulse response of the channel. In STBC system an assumption is taken that channel impulse response remains same for two consecutive symbols, practically it is not the case for $m < 1$. Hence performance of STBC-OFDM degrades for $m < 1$ as compared to $m \geq 1$.

Simulation results in Fig. 6.2 shows comparisons of high-rate STBC and Alamouti STBC under m -Nakagami fading channel for different values of m for frequency flat fading environment. It seen that at lower value of SNR for $m > 1$ effective throughput is high in case of both high-rate STBC as well as full-rate STBC as compared to $m = 1$ and effective throughput is low for $m < 1$ compared to $m = 1$ for both systems. We also seen that effective throughput of high-rate at high SNR is 2.5 becomes constant whereas in full-rate STBC get effective throughput 2 at high value of SNR.

Fig. 6.3 shows performance of proposed low complexity zero forcing for frequency-selectivity of channel. It achieves maximum effective throughput 2.22 per channel use when value of $m < 1$ whereas for $m > 1$ and $m = 1$ effective throughput is less than 2.22 but more than 2 (i.e. in case of full rate STBC for frequency flat fading channel) which is higher than full-rate STBC by reducing complexity of receiver compared to classical ZF.

7.2 Future Scope

- Proposed high-rate STBC with low-complexity ZF receiver can be extended for high-rate STBC-OFDM system.
- The proposed work can be extended for doubly selective fading channel. STBC-OFDM system performance evaluation in the presence of impulsive noise is also a subject of future work.
- The work given in this thesis can be extended for higher spatial diversity scheme.

REFERENCES

- [1] T. S. Rappaport, *Wireless Communications*, 3rd ed. Delhi: Prentice Hall, 1996.
- [2] Zhengjiu Kangetal., “Nakagami-m fading modeling in the frequency domain for OFDM system analysis,” *IEEE Commun.Lett.*, vol. 7, no. 10, pp. 484 – 486, Oct. 2003.
- [3] G. J. Foschini, “Layered space-time architecture for wireless communication in a fading environment when using multi element antennas,” *Bell Labs Tech. J.*, vol. 1, no. 2, pp. 41–59, 1996.
- [4] Siavash M. Alamouti,” A simple transmit diversity technique for wireless communications”, *IEEE J. Sel. Area. Commun.*, vol. 16, no. 8, pp. 1451 – 1458, Oct. 1998.
- [5] A. Goldsmith, *Wireless Communications*, 2nded. US: Cambridge University Press, 2005.
- [6] S. B. Weinstein, “Data transmission by frequency division multiplexing using the discrete fourier transform,”*IEEE Trans. Commun. Technol.*, vol. 19, no. 5, pp. 628 – 634, Oct. 1971.
- [7] Bernard Sklar, *Digital Communications*. 2nd ed. Los Angeles: Prentice-Hall, 2001.
- [8] R. Van. Nee and R. Prasad, *OFDM for Wireless Multimedia Communication*.London: Artech house Publisher, 2000.
- [9] J. Armstrong, “OFDM for optical communication - Invited tutorial,” *IEEE J. Light wave Technol.*, vol. 27, no. 3, pp. 189-204, Feb. 2009
- [10] D. Agrawal, V. Tarokh, A. Naguib, N. Seshadri , “Space-time coded OFDM for high data rate wireless communication over wideband channels,”*IEEE Veh. Technol. Conf.*, vol. 3, pp. 2232 – 2236, 18-21 May 1998.
- [11] Murat Uysal, Naofal Al-Dhahir “A Space-time block coded OFDM scheme for unknown frequency selective fading channels,” *IEEE Commun. Lett.*, vol.5, no.10, pp. 393 – 395, Oct. 2001.
- [12] Vahid Tarokh, “Space–time block codes from orthogonal designs,” *IEEE Trans. Inf. Theory*, vol. 45, no. 5, pp. 1456 – 1467, July 1999.

- [13] Sushanta Das, "Novel full-diversity high rate STBC for 2 and 4 transmit antennas," *IEEE Commun. Lett.*, vol. 10, no. 3, pp. 171 - 173 , Mar. 2006.
- [14] V. Tarokh, H. Jafarkhani, and A. R. Calderbank, "Space-time block coding for wireless communications: Performance results," *IEEE J. Sel. Areas Commun.*, vol. 17, no. 3, pp. 451–460, Mar. 1999.
- [15] Chi-Hsiao Yih, "Iterative interference cancellation for OFDM signals with blanking nonlinearity in Impulsive noise channels," *IEEE Signal Process.Lett.*, vol. 19, no. 3, pp. 147 – 150, Mar. 2012.
- [16] Xiaoxin Zhang, Yuping Zhao and Li Zou, "An Efficient Impulsive Noise Mitigation Scheme for Over-Sampled OFDM Systems," *IEEE Trans. Consum.Electron.*, vol. 55, no. 2, pp. 147 - 150, May 2009.
- [17] Ku Li, "Impulsive noise rejection in BPSK modulated OFDM system," *IEEE Int. conf. Comput. Sci. Service Syst.*, pp. 2282 - 2285 , 27-29 June 2011.
- [18] R.W chang, "A Theortical study of performance of an orthogonal multiplexing data transmission scheme," *IEEE Trans. Commun. Technol.*, vol. 16, no. 4, pp. 529-540, Aug. 1968.
- [19] Amit Grover et. al., "Characterisation of impulse noise effects on space-time block-coded orthogonal frequency division multiplexing (OFDM) signal reception," *Int. J. Physical Sci.* , vol. 7, no. 25, pp. 4003-4011, June 2012.
- [20] Kun-WahYipand Tung-Sang Ng, "A simulation model for nakagami-m fading channels, $m < 1$ ", *IEEE Trans. Commun.*, vol. 48, no. 2, pp.214 - 221 , Feb. 2000.
- [21] Li Tang, Zhu Hongbo, "Analysis and simulation of Nakagami fading channel with Matlab," *Proc. Asia-Pacific conf. Environmental Electromagnetic*, pp. 490-494, 4-7 Nov. 2003.
- [22] S. Lu., B. Narasimhanand, N. Al-Dhahir, "A novel FBC-OFDM scheme for doubly- selective channels,"*IEEE Trans. Veh.Technol.*,vol.58, no.5, pp.2573-2578, June 2009.
- [23] Kwanghoon Kim, Hyuncheol Park, and Hyuck M. Kwon, "Rate-compatible SFBC OFDM under rapidly time-varying channels,"*IEEE Trans. Commun.*, vol.

- 59, no. 8, pp. 2070-2077, Aug. 2011.
- [24] Luis Miguel Cortés-Peña, "MIMO Space-Time Block Coding (STBC): Simulations and Results," *Perons. Mobile Commun.*, vol. 9, pp. 1-8, Apr. 2009.
- [25] Anil Mengi and A. J. Han Vinck, "Successive Impulsive Noise Suppression in OFDM," *IEEE Int. Symp. Power Line Commun.*, pp. 33 - 37, 28-31 Mar. 2010.
- [26] John G. Proakis, *Digital Communications*, 4th ed. Dehli: McGraw-Hill, 2001.
- [27] W.Y. Zou and Y. Wu, "COFDM: An Overview," *IEEE Trans. Broadcast.*, vol. 41, no. 1, pp. 1-8, March 1995.
- [28] W.Su and X.-G. Xia, "Signal constellations for quasi-orthogonal space time block codes with full diversity," *IEEE Trans. Inf. Theory*, vol. 50, pp. 2331–2347, Oct. 2004.
- [29] A.V. Oppenheim and R.W Schafer, *Discrete-Time Signal Processing*, Dehli: Prentice-Hall, 1989.
- [30] H. A. Suraweera and J. Armstrong, "Noise bucket effect of impulse noise in OFDM," *IEEE Electron Lett.*, vol. 40, no. 18, pp. 1156-1157, Sep. 2004.
- [31] A. Papoulis, *Probability Random Variables and Stochastic Processes*, McGraw-Hill, 2008.
- [32] J. Jang, H. Won, and G. Im, "Cyclic prefixed single carrier transmission with SFBC over mobile wireless channels," *IEEE Sig. Process.Lett.*, vol. 13, no. 5, pp. 261 – 263, June 2001.
- [33] G. J. Foschini and M. J. Gans, "On limits of wireless communications in a fading environment when using multiple antennas," *Wireless Person.Commun.*, vol. 6, no. 3, pp. 311–335, Mar. 1998.
- [34] E. Lindskog and A. Paulraj, "A transmit diversity scheme for channels with interference," *Proc. IEEE Int. Conf. Commun.*, vol. 1, pp. 307–311, June 2000.
- [35] Gerhard Boch, "Space-time block codes versus space-frequency block codes," *IEEE Veh. Technol. Conf.*, vol. 2, pp. 22-25, Apr. 2003.
- [36] I. E. Telatar, "Capacity of multi-antenna Gaussian channels," *Eur. Trans. Telecommun.*, vol. 10, no. 6, pp. 585–595, Dec. 1999.
- [37] Z. Liu, G. Giannakis, A. Scaglione, and S. Barbarossa, "Decoding and equalization of unknown multipath channels based on block precoding and

- transmit-antenna diversity,” *Proc. Asilomar Conf. Signal Syst.*, vol. 2, pp. 1557–1561, Oct. 1999.
- [38] H. Bolcskei and A. J. Paulraj, “Space-frequency coded broadband OFDM systems,” *Proc. IEEE Wireless Commun. Network. Conf.*, pp. 1–6, 23-28 Sep. 2000.
- [39] N. Al-Dhahir, “Single-carrier frequency-domain equalization for space-time block-coded transmissions over frequency-selective fading channels,” *IEEE Commun. Lett.*, vol. 5, no. 7, pp. 304–306, Jul. 2000.
- [40] S. Zhou and G. Giannakis, “Single-carrier space-time block-coded transmissions over frequency-selective fading channels,” *IEEE Trans. Inf. Theory*, vol. 49, no. 1, pp. 164–179, Jan. 2003.
- [41] N. Al-Dhahir, “Overview and comparison of equalization schemes for space time coded signals with application to EDGE,” *IEEE Trans. Signal Process.*, vol. 50, no. 10, pp. 2477–2488, Oct. 2002.
- [42] S. Geirhofer, L. Tong, and A. Scaglione, “Time-reversal space-time coding for doubly-selective channels,” *Proc. IEEE Wireless Commun. Network. Conf.*, vol. 3, pp. 1638–1643, 3-8 Apr. 2006.
- [43] M.M Islam, M.R Haque and M. G Mostafa, “Performance analysis of Nakagami-m MIMO channel in presence of multiple keyhole,” *Int. Conf. Inf. Network.*, vol.10, pp.33.-334, Feb. 2014.
- [44] Lee, Donghun, “Performance analysis of combining space-time block coding and scheduling over arbitrary Nakagami fading channels,” *IEEE Trans. Wireless Commun.*, vol.13, no. 5, pp. 2540-2551, May 2014.