

Design of MIMO and MU-MIMO Antennas for Modern High Data Rate Wireless Systems

*Dissertation submitted in the partial fulfillment of
requirements for the award of degree
of*

**Master of Engineering
in
Wireless Communications**

Submitted by
Deepak Saluja
Roll No. 801363009

Under guidance of
Dr. Rajesh Khanna
Professor, ECED



Electronics and Communication Engineering Department

THAPAR UNIVERSITY

(Established under the section 3 of UGC Act, 1956)

PATIALA-147004 (PUNJAB)

July, 2015

CERTIFICATE AND DECLARATION

I, Deepak Saluja hereby declare that the work which is being presented in the dissertation entitled "**Design of MIMO and MU-MIMO antennas for high data rate wireless systems**", by me in partial fulfillment of the requirement for the award of degree of M.E. in Wireless Communication submitted in Electronics and Communication Engineering Department of Thapar University, Patiala is an authentic record of my own work carried out under the guidance of **Dr. Rajesh Khanna** (Professor), Electronics & Communication Engineering Department.

The matter presented in this dissertation has not been submitted in any other University/Institute for the award of degree.

Date: 14-07-15

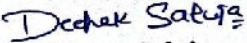
Deepak Saluja

Roll no. 801363009

This is to certify that the above statement made by the student is correct to the best of my Knowledge and belief.

Date: 14/7/15

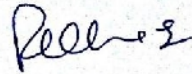

Dr. Rajesh Khanna
Professor
Thapar University

Countersigned By:-

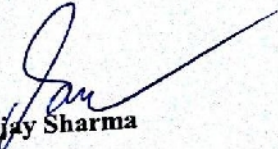
Dr. Sanjay Sharma
Professor & Head
ECED, Thapar University

Dr. S.S. Bhatia

Dean of Academic Affairs
Thapar University

ACKNOWLEDGEMENT

First of all, I would like to express my gratitude to **Dr. Rajesh Khanna**, Professor, Electronics & Communication Engineering Department, Thapar University Patiala for his patient guidance and support throughout this report work. I am truly very fortunate to have the opportunity to work with him. I found his guidance to be extremely valuable.

I am also thankful to **Dr. Sanjay Sharma**, Head, Department of Electronics and Communication, Thapar University, Patiala, for providing the opportunity to carry out the present work.

I also want to express my gratitude to **Dr. Amit Kumar Kohli**, P.G. Coordinator, Electronics and Communication Engineering Department, the entire faculty and staff of Electronics and Communication Engineering Department for their help in all possible ways for Successful completion of this work. I thank all those who have contributed directly or indirectly in this work. Lastly, I would like to thank my parents and friends for their constant support and encouragement throughout making of this report .They have always wanted the best for me and I admire their love and sacrifice.

Deepak Saluja
Roll No. : 801363009

Abstract

The trends in wireless communication are changing day by day. To meet the challenges of modern day wireless systems, the multiple input multiple output (MIMO) antennas are proposed in the report. The high data rate requirement for modern day wireless system makes it necessary to adopt MIMO systems. The size of the device is another constraint after data rate of the systems. The planar antennas proved as revolution in the antenna design enables achievement in terms of size reduction and conformal nature of antenna. The MIMO planar antennas are quite desirable for the reason.

The literature survey is presented in context of MIMO systems. The different type of MIMO antennas are discussed by authors in the literature. The various methods are presented by the authors in literature to increase isolation between the antenna elements so to decrease correlation coefficient and to increase the data rate.

The planar MIMO antennas are characterized by specific parameters other than the parameters used in context of antenna design. The planar antennas are characterized by the parameters like Scattering parameters, Coupling coefficient, Isolation, Correlation coefficient, ECC (Envelope correlation coefficient), Mean effective gain (MEG) and branch power ratio etc. The planar MIMO antennas can be understand as evolution of planar antennas from rectangular Microstrip patch antenna. In this study, the MIMO antennas are presented evolving from the simple microstrip patch antenna. The data rate of system depends on the correlation between different antenna elements in MIMO systems.

The simple rectangular planar antenna is designed and matching is achieved by inset feed. The designed antenna resonates at 2.4 GHz in the dominant mode. The gain for the proposed antenna is also discussed. After design of antenna element the MIMO system is proposed and analyzed. The value of S11, S12 is calculated and the gain parameter is also presented in the report for the proposed MIMO systems.

Table of Contents

Certificate and Declaration	i
Acknowledgements	ii
Abstract	iii
Table of Contents	iv
List of Abbreviations	vii
List of Figures	ix
List of Tables	xi
1 Introduction	1
1.1 Introduction	1
1.2 Overview of MIMO systems	2
1.2.1 Spatial Multiplexing	3
1.2.2 Space time coding	4
1.3 Advantages of MIMO system	5
1.4 Massive MIMO	6
1.5 Antenna Design Challenges in Modern Wireless Communication Systems	6
1.6 Overview of multiband antenna	6
1.7 Planar MIMO antennas	7
1.8 MIMO antenna array	9
1.9 Objectives of the thesis	9
1.10 Organization of the thesis	10
2 Literature Survey	11
2.1 Research Gap	17
2.2 Objectives of the thesis	18
2.3 Methodology	18

3	Electromagnetic principles and the parameters	19
3.1	Microstrip patch antenna computations	19
3.2	Correlation Coefficient	20
3.3	Isolation	21
3.4	Total active reflection coefficient	21
3.5	Mean effective gain	22
3.6	Diversity gain	23
3.7	Branch power ratio	24
3.8	Rumsey's Principle	24
3.9	HCR principle	25
3.10	Capacitive loading	26
3.11	Principle of pattern multiplications	27
4	Results and Discussion	31
4.1	Basic designs	31
4.1.1	Design of inset fed microstrip patch antenna	31
4.1.2	Reflection coefficient analysis of the design	31
4.1.3	Current density analysis of the design	32
4.1.4	Radiation pattern analysis of design	33
4.2	MIMO Antennas	33
4.2.1	Design Considerations	33
4.2.2	Reflection Coefficient analysis of design	34
4.2.3	Radiation pattern analysis of design	34
4.3	F-MIMO-PIFA Antenna for LTE/4G/WiFi	35
4.3.1	Introduction to proposed antenna	35
4.3.2	Design considerations	35

4.3.3	Reflection Coefficient analysis of design	37
4.3.4	Field distribution	39
4.3.5	Radiation pattern analysis of design	40
4.3.6	MIMO parameters characteristics for proposed design	41
4.4	MU-MIMO	42
4.4.1	Introduction	42
4.4.2	Design Considerations	42
4.4.3	Reflection coefficient analysis of proposed design	43
4.4.4	Radiation pattern analysis of design	44
4.4.5	MU-MIMO property analysis	45
5	Conclusions and Future scope	47
5.1	Conclusions	47
5.2	Future Scope	48
	References	49
	List of the publications	53

LIST OF ABBREVIATIONS

1G	First generation
2G	Second generation
2.5G	Enhanced Second Generation
2.75G	Enhanced data rate Generation
3G	Third generation
4G	Fourth generation
5G	Fifth generation
AMPS	Advanced Mobile Phone System
GSM	Global System for Mobile Communications
CDMA	Code Division Multiplexing Access
GPRS	General Packet for Radio Services
EDGE	Enhanced Data rates for GSM Evolution
UMTS	<i>Universal Mobile Telecommunications System</i>
LTE	Long Term Evolution
MIMO	Multiple Input Multiple Output
SNR	Signal to Noise Ratio
SISO	Single Input Single Output
WiFi	Wireless Fidelity
WiMax	Worldwide Interoperability for Microwave Access
UWB	Ultra-Wide-Band
DVB	Digital Video Broadcasting
GPS	<i>Global Positioning System</i>
EGSB	Expanded Granular Sludge Bed
DCS	Digital Communication System
PCS	Personal Communication System
LAN	Local Area Network

TARC	Total Active Reflection Coefficient
WCDMA	Wideband Code Division Multiplexing Access
ECC	Envelope Correlation Coefficient
PCB	Printed Circuit Board
WLAN	Wireless Local Area Networks
PIFA	Planar Inverted-F Antenna
VSWR	Voltage Standing Wave Ratio
EBG	Electromagnetic Band Gap
DGS	Defected Ground Structure
MEG	Mean Effective Gain
HCR	Hohlfeld-Cohen-Rumsey

List of Figures

Figure 1.1	Different generations of wireless communications	1
Figure 1.2	MIMO spatial multiplexing method	4
Figure 1.3	MIMO space time coding implementing	4
Figure 1.4	The example of space time coded MIMO	5
Figure 1.5	Radio system front end section of Laptop	5
Figure 1.6	The different configuration of Microstrip patch antenna for MIMO configuration	9
Figure 3.1	The flowchart for calculation of the microstrip patch antenna Parameters	19
Figure 3.2	The structure following Rumsey's principle	25
Figure 3.3	Hohlfeld-Cohen-and-Rumsey (HCR) Conditions.	26
Figure 3.4	The principle of pattern multiplication for two antenna elements	28
Figure 3.5	The principle of pattern multiplication for four element antennas Array	29
Figure 3.6	The final pattern for four element antenna array	29
Figure 4.1	(a) The microstrip patch antenna with microstrip line feed (b) The microstrip patch antenna with inset feed	31
Figure 4.2	The S11 parameter for microstrip line feed without inset feed and With inset feed.	32
Figure 4.3	The current density of proposed antenna at 2.4 GHz	32
Figure 4.4	The radiation pattern of the inset fed antenna at frequency 2.4 GHz.	33
Figure 4.5	The MIMO system with two inset feed antenna elements	33
Figure 4.6	The S-parameters versus frequency for the proposed design	34
Figure 4.7	The radiation pattern of proposed antenna at 2.52 GHz.	35
Figure 4.8	Antenna Element of proposed MIMO	36
Figure 4.9	The 3D view of proposed antenna	36
Figure 4.10	Different prospective views of proposed antenna and detailed	37

	dimensions of antenna	
Figure 4.11	Fabrication of the proposed antenna systems in comparison to Samsung 4.5 inch mobile phone	37
Figure 4.12	Simulation and fabrication results for antenna	38
Figure 4.13	S11 (dB) for the proposed antenna element	38
Figure 4.14	Scattering parameters for antenna with air and solid material ($\epsilon_r = 1$) as substrate.	39
Figure 4.15	The field distribution of proposed antenna (a) at 1.9 GHz (b) at 2.4 GHz	40
Figure 4.16	Radiation pattern of proposed antenna	40
Figure 4.17	Radiation pattern of F- MIMO PIFA at (a) 1.9 GHz and (b) 2.4 GHz	41
Figure 4.18	ECC versus frequency (GHz) for proposed MIMO systems	41
Figure 4.19	The MIMO system with four inset feed antenna elements	42
Figure 4.20	Reflection coefficient of each antenna element	43
Figure 4.21	S11 and S21 for 2 antenna array elements as single MIMO element	43
Figure 4.22	Gain (dBi) versus frequency (GHz) for different values of antenna element spacing	
Figure 4.23	The side lobe level (SLL) versus antenna element spacing	44
Figure 4.24	The directivity versus antenna element spacing	45
Figure 4.25	Radiation pattern of proposed antenna	45
Figure 4.26	(a) ECC versus frequency and (b) Diversity gain versus frequency	46

List of Tables

Table 1.1	The frequency spectrum of different access technologies	8
-----------	---------------------------------------------------------	---

Chapter 1

Introduction

1.1 Introduction

The history of wireless communication is quite vast and continuously driving need for higher speeds. The communication has witnessed different phases during their growth. The broad era started from physical transport communication in 490 B.C. and extended to electronic technology based communication in year 1897 when Marconi patented communication system by complete wireless system of communication. Since the inception of electromagnetic wave communication by Marconi, it has undergone tremendous amount of changes. The purpose of communication is completely changed and wired systems are completely replaced by wireless communication. The free space is used as a channel for wireless communication which proves to be dispersive in nature. The challenges are met with growing electronic technologies and evident by functions embed in modern day mobile devices. The era of improvement in wireless communication is still evident from everyday evolution of latest technologies. The standards for wireless communication are growing like 1G, 2G, 2.5G, 2.75 G, 3G, 4G and 5G which are briefed in the figure 1.1.

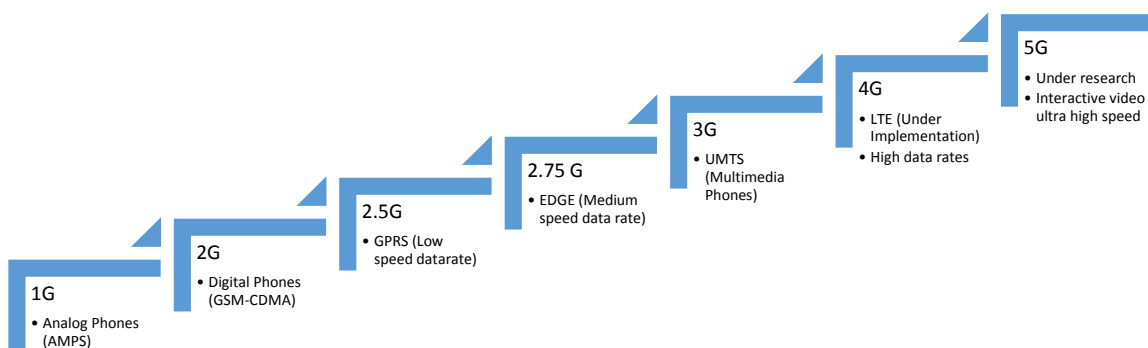

Figure 1.1: Different generations of wireless communications

Though wired communication was existing well before the introduction to wireless communication, the wireless communication was the most happening revolution in this world. The user equipment used in the wireless communication system was named as mobile phone. The different phases of wireless communication has been divided into generations. The analog phones during 1st generation of wireless communication offered voice communication as its only service. Also its access was limited to upper class economy public only. But as the digital technologies are introduced in wireless communication, the 2nd generation phones were open to general public. The 2nd generation was named as global system for mobile communication. Later addition of data services was termed as 2.5 G also named as general packet for radio services (GPRS). The improvement in data service provider technologies was resulted in introduction to 2.75 G (Enhanced data rate for GSM evolution). The 3G phone emerged as high data rate support to multimedia services like video calling and most popular in India from 2012 onwards. In some regions of India 4th generation phones have also been employed and now the technology up-gradation is targeting reliable, small size, energy efficient, low cost and high data rate application. The 5G technology is emerging as technology of future and targeting the antenna design which proved to be bottleneck in previous technologies. The research from antenna community have make the way possible for the next technology termed as massive MIMO. The expectations from technologies are huge and the thesis has been written keeping in view the design for 5th generation wireless systems.

1.2 Overview of MIMO systems

With advancement of technologies the performance criteria for the next generation wireless systems are ever increasing. The performance criteria for modern day wireless systems are listed as under

- a. Higher data rate
- b. Good gain
- c. Small size
- d. High bandwidth

One approach for achieving targets mentioned above can be the introduction of MIMO (Multiple Input Multiple Output systems) in modern day wireless systems. This term describe

the use of multiple antennas at both the transmitter (multiple input) and receiver (multiple output).

Since advantage of MIMO technology the next generation wireless technologies will be embed with multiple antennas. As the requirement of MIMO technology is to obtain uncorrelated antennas. The correlation coefficient given as parameter in last chapter decides the frequency range for which MIMO antenna will work. In figure 1.2 the MIMO technology has highest throughput and data rates.

The terms and approaches used in MIMO communication are classified into two broad categories given as

- a. Spatial multiplexing
- b. Space time coding.

1.2.1 Spatial Multiplexing

Spatial multiplexing uses different data with multiple streams between the transmitting and receiving antenna. Figure 1.2 depicts the example of spatial multiplexing. As described in the figure, if one stream carries 20 Mbps of “Data 1” and a second stream carries 20 Mbps of “Data 2”, the receiver device could receive at 40 Mbps. In comparison to the conventional design of single transmitter, it is assumed that the two antennas are used for transmission and termed as 2x1 MISO system i.e. 2 transmitter antennas and 1 receiver antennas. In addition, if 4x2 MIMO systems was used (4 transmitting antennas and 2 receiving antennas) then it could potentially offer data rate of 80 Mbps.

Spatial multiplexing is commonly used for increasing the capacity of the channel or to improve signal to noise ratio. In the spatial multiple techniques the multiple antennas are installed and the signals received by different antennas are processed by signal processing techniques. The quality of the signals received at the receiver is dependent on the propagation channel. If the channel is uncorrelated then the streams at the receiver then signals can easily be separated. The spatial multiplexing either can be used with or without the knowledge of the fading channel. In general spatial multiplexing can be applied to both deterministic and non-

deterministic channels. To calculate the number of independent streams, the $\text{MIN}(M, N)$ is considered. Here M and N are the numbers of the transmitting and receiving antennas, respectively, in the MIMO system.

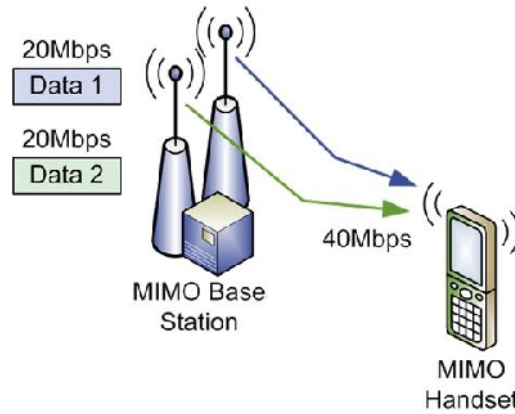

Figure 1.2: MIMO spatial multiplexing method [1]

1.2.2 Space time coding

On the other hand, the space time coding methods use multiple antennas to transmit the same information. Figure 1.3 illustrate the example of space time coding. It is clearly shown that the set of data “Data 1” is the same for both the blue and the green channel. But the data is differently treated by the two antennas [2].



Figure 1.3: MIMO space time coding [2]

The most important parameter for the space time coding is channel matrix. The generic form of space time coded MIMO is shown in figure 1.4. The matrix can be defined by the equation

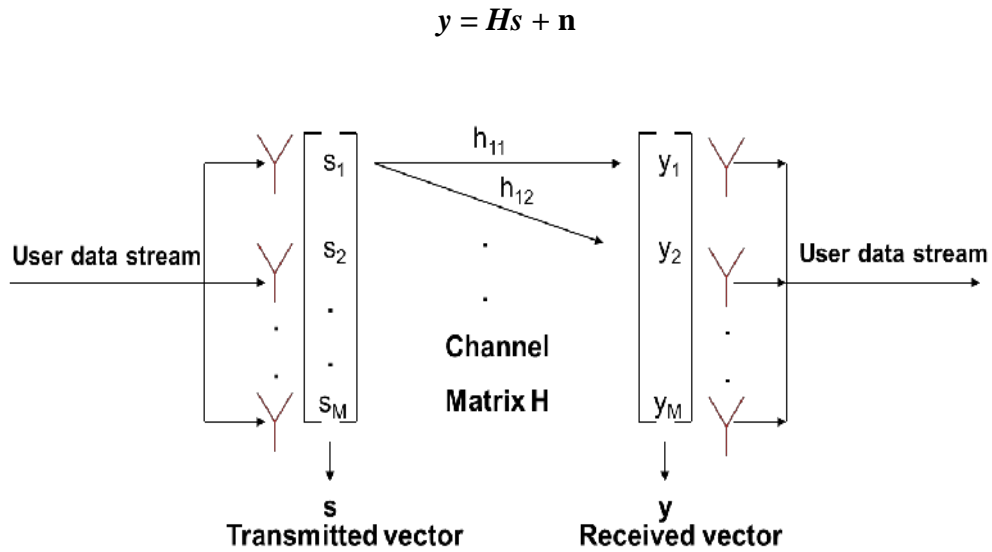

Figure 1.4: The example of space time coded MIMO

Here, s = signal vector for Tx side and y = signal vector for the Rx side

The example of H matrix for the above system is shown below.

$$\mathbf{H} = \begin{matrix} & \xleftarrow{M_T} & & \xrightarrow{M_T} \\ \uparrow & \begin{bmatrix} h_{11} & h_{21} & \dots & h_{M1} \\ h_{12} & h_{22} & \dots & h_{M2} \\ \cdot & \cdot & \dots & \cdot \\ h_{1M} & h_{2M} & \dots & h_{MM} \end{bmatrix} & \downarrow \\ M_R & & & \end{matrix}$$

Here, h_{ij} is a Complex Gaussian random variable and the fading model considers communication between i^{th} transmit antenna and j^{th} receiving antenna

1.3 Advantages of MIMO System

MIMO systems have several advantages compared to SISO system. Some of the principle advantages are:

- Increased channel capacity
- Reduced transmitting power
- Higher link gain

- Faster data rate
- Better reliability
- Improve network throughput
- Improve coverage without requiring additional bandwidth

1.4 Massive MIMO

Massive MIMO is backbone for 5th generation mobile phone systems. Evolution of multimedia applications derived the need of high speed broadband internet while on move. The mobile broadband internet in conventional scenario was achieved using more spectrum. But introduction of MIMO system enabled increase in spectral efficiency. Which in terms resulted in increased data rate of mobile internet without need of extra spectrum which is costly and already occupied by different services. As wireless systems has bottleneck in designing of antennas, multiuser MIMO antenna require multiband antennas. In the thesis various design aspects of Multiband MIMO antennas are discussed for mobile phones. Three layer model is assumed for controlling different bands of MIMO antennas.

1.5 Antenna Design Challenges in Modern Wireless Communication Systems

- Placement of multiple antennas
- Device size reduction and compactness
- To cover multiple band of operation
- Parameters optimization
- Low cost
- Light weight
- Robustness
- Flexibility and ease of mass production

1.6 Overview of multiband antenna

In this era, multiple technologies consolidated together in a single device, require multiband antennas on a device circuit board. The users operate with multiple technology in a single

device which further drive the need of multiband antennas. Which otherwise require the multiple antennas in mobile phone and may result in size increase for the devices. The multiband antennas can simultaneously operate in multiple frequencies, covering all the required wireless communication frequencies. Example of the multi-radio platform in a single device is shown in Figure 1.5 [3]. The system architecture so presented include WiFi, WiMAX, 3G, UWB, Bluetooth, TV-DVB, GPS and the Personal Communication system (at 60 GHz band) that could be implemented using single Multiband antenna.

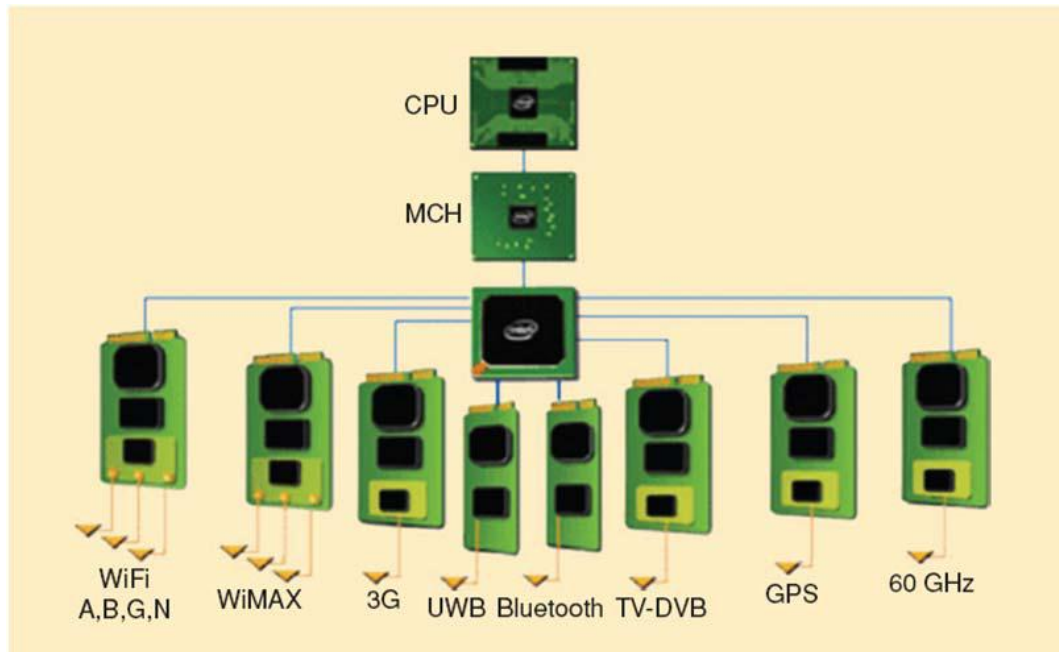

Figure 1.5: Radio system front end section of Laptop

The multiband antennas are widely used for this type of multi-radio platform. The frequency spectrum for different access technology is listed in table 1.1.

1.7 Planar MIMO antennas

LTE is considered to be upcoming and most promising technology. The antenna for LTE needs to be MIMO type of antenna. The other requirement of antenna for LTE is that it should be planar in nature. So the aim of the report is to emphasize on Planar MIMO antennas. Microstrip patch antennas are known to be planar antenna. In Microstrip patch antenna two different element antenna are fabricated on single substrate. The different methods exist in literature to

reduce the correlation between multiple antennas. The MIMO planar antenna is perfect candidate for high data rate modern day wireless systems. The planar technology has got popular in the last decade because of its advantages of integration of antenna with PCB circuit. The figure 1.6 describe the planar MIMO antennas for different configurations. The different configuration affects the correlation between multiple antennas. The two types of antennas shown in the figure. The circular patch shaped microstrip antenna element and slotted polygonal microstrip patch antenna.

Table 1.1: The frequency spectrum of different access technologies.

Access Technologies	Frequency range (MHz)
GSM	824 – 894
EGSM	890 – 960
LTE	1850-1910 MHz and 1930-1990 MHz
PCS	1850 – 1990
UMTS	824 – 894 1710 - 2170
Bluetooth, Wireless LAN 802.11b/g	2400-2483
Wireless LAN 802.11 a	5150-5250
GPS	1559-1610

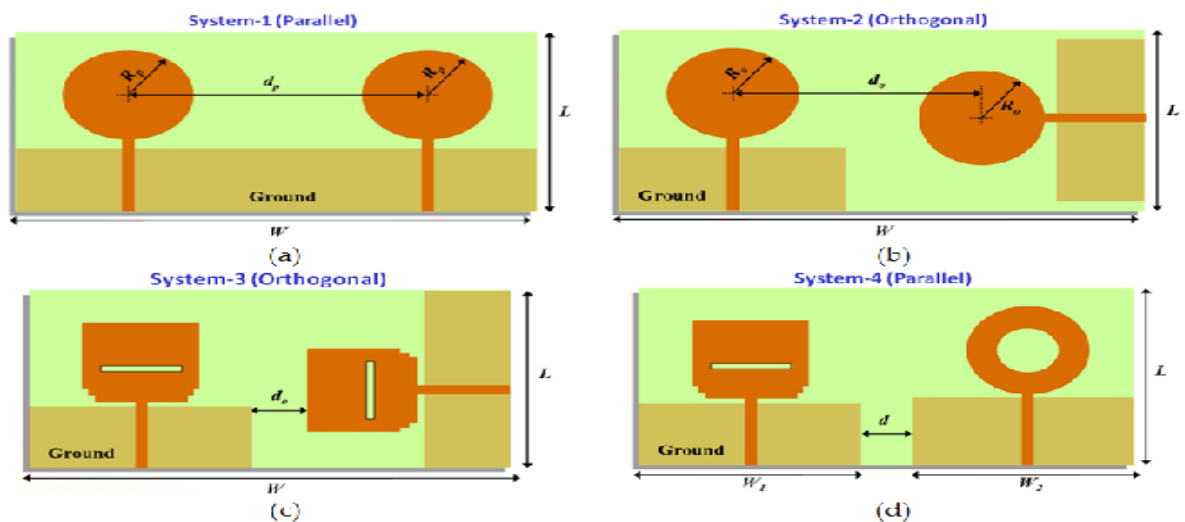

Figure1.6: The different configuration of Microstrip patch antenna for MIMO configuration

1.8 MIMO Antenna array.

Modern day wireless device requires high data rate and small size of the devices. MIMO technique is introduced in wireless to improve data rate of devices. The MIMO technique uses space diversity to achieve enhancement in data rate. However in order to achieve highly directional beam it is important to study MIMO antenna in the form of array. With the help of an antenna array, it is possible to increase gain and directivity of an antenna. In MIMO array, an array is design with number of elements and then two similar arrays are used to work it as MIMO. By doing so it is possible to achieve the combined advantages of array as well as MIMO i.e. high gain and directional beam along with high data rate. In order to work an array as MIMO, phase excitation to different elements plays an important role. Single antenna element usually gives low value of directivity and radiation pattern of it is extensive. So single element antennas are not always sufficient for required antenna gain and radiation pattern. However some applications like long distance communication requires antennas with very high gain (directivity). The increase in gain can be achieved by increase in electrical length of the antenna. In terms the electrical size of antenna either can be increased by increasing the dimensions of antenna elements or by using lumped elements loading of the antennas. In-fact the method to increase the directivity of antenna is the use of antenna arrays. Different type of antennas arrays exist in the literature. However in uniform linear array as the length of array is increase in order to improve the directivity of antenna, secondary lobes or minor lobes always appears in the pattern. A study of uniform array using the principle of pattern multiplication reveals that the resultant pattern of antenna array contains secondary lobes whenever the element that produces unit pattern or elements that produces group or space factor pattern have a spacing greater than $\lambda /2$. By reducing spacing of array elements to $\lambda /2$, the resultant pattern is eight shape pattern and having only primary lobes.

1.9 Objectives of the thesis

The objectives of proposed research are given as

1. To design planar monopoles for desired specifications
2. The parametric study of different decoupling structures.
3. To propose MIMO antenna for next generation wireless technologies.

4. To propose MIMO for multiband operations.
5. Comparison of measured and simulated results.

1.10 Organization of the thesis

The thesis is organized in five chapters.

In **Chapter 2** literature review of different types of MIMO antennas including novel small size MIMO-PIFA Antenna and MIMO array antenna are presented. The chapter covers literature survey for basic microstrip MIMO antenna, parametric analysis of antennas, PIFA antennas, array antennas and their performance analysis. This chapter also includes research gap, objectives of thesis and methodology of work.

In **chapter 3** parametric analysis of MIMO antennas are performed. This chapter includes analysis in the form of different parameters viz. correlation coefficient, isolation, total active radiated power (TARC) and branch power ratio. This chapter also includes electromagnetic principles of antenna.

In **Chapter 4** the proposed work for dissertation and the result of proposed thesis work is presented and discussed. This chapter discuss the simulation result of proposed antenna designs. The simulation result of various performance parameters such as return loss characteristics, far field radiation pattern and envelope correlation coefficient (ECC) variation with frequency (GHz) are presented. The comparison of simulation and measured result of return loss characteristics is also presented in this chapter.

Chapter 5 forms the summary of thesis and finally the scope of future work has been presented.

Chapter 2

Literature Survey

The survey of literature for MIMO system starts with introduction to conventional antennas. Antenna was first introduced in 1910 and coil antennas were quite common in 1920s. The advancement of antenna is derived by the needs of wireless systems. The need for MIMO systems are derived by high data rate in modern day systems. The immense research have already been carried out for MIMO implementation in context of signal processing. The implementation of MIMO antenna is also important aspect of modern day wireless systems. The following section describe the literature survey for MIMO antennas.

Lee et.al in [3] has proposed MIMO multiband antenna which operates at GSM 900/1800/WCDMA band. The value of ECC lies below 0.5 for the frequency range. The antenna occupies a volume of 21.5 mm X 10 mm X 5 mm. Authors uses FR4 substrate and the antenna is planar inverted F type. The authors contribute to higher data rate system by using multiple antennas i.e. MIMO multiband antenna.

WU et.al in [4] designed a multiband MIMO antenna that uses planar technology. The MIMO system consists of two monopole elements with symmetrical configuration. The antennas are printed parallel to each other at upper and lower corners of PCB. Author claims that much enhanced bandwidth in upper band can be obtained by using parasitic element in each monopole. The FR4 substrate is proposed for antenna having dielectric constant of $\epsilon_r=4.9$ and loss tangent of 0.025. The antenna occupies a volume of 50X110X0.8 mm³. Two monopole antennas are printed on top side of PCB to achieve good diversity performance and lower correlation coefficient. A special slit cut on ground plane is to reduce coupling and increase isolation of two elements. The value of isolation is found to be -13 dB in LTE band and -15 dB in upper band.

Han and Choi proposed a small size MIMO antenna with strip printed on substrate in [5]. The MIMO antenna consists of simple two strip monopole as the patch and embedded chip inductor

for compensation of capacitance. The capacitance results from shortening of radiating strip. Author uses FR4 substrate having $\epsilon_r=4.4$ and antenna occupies volume of 25mmX66mmX0.8mm. The fabricated antenna has isolation of -18dB at lower band and lower than -12dB at higher band. The peak gain of two antenna elements are -0.52 dBi and -0.64 dBi at LTE band; 13, 3.8 dBi and 3.5 dBi at WCDMA band and 3.4 dBi and 3.2 dBi at WiBro band respectively.

Krewski et.al in [6] design a MIMO antenna system for application in laptops. Author analyze characteristics modes of laptop chassis to use in antenna design. A multiband MIMO antenna system with 2 ports is introduced for LTE in their lower frequency bands and WLAN bands applications. Author envision an extension to more ports as future scope of the work.

Kulkarni and sharma in [7] proposes a small size multiband antenna attributed by low cost. The printed inverted F-antenna (PIFA) type of antenna is proposed. This structure designs on a low cost FR4 substrate ($\epsilon_r=4.4$, loss tangent =0.02 and thickness of substrate= 1.6 mm). The proposed antenna element dimensions are 9.3mm X 25mm X 5mm. The proposed Antenna ground plane dimensions are 25mmX 43mm. Author observed correlation coefficient below 0.5 at LTE band of frequencies. The antenna is proposed to work in the 3rd and 7th bands of LTE.

Jamil et.al in [8] proposes a multiband MIMO antenna using hybrid meander-Koch monopole patch. The antenna is proposed to be compact in size. In the paper, to practice the diversity, antenna has been arranged as a two elements array. To study effect of mutual coupling, four antennas configurations are analyzed for the two antenna elements. Author considers the size optimization as a major challenge in multiband MIMO antenna while maintaining its performance characteristics. Unfortunately authors found that all MEAs performs strong correlation between their antenna elements.

Shin et.al in [9] proposes and designs diversity and MIMO antenna. The proposed antenna diversity system works in frequency band of DCS/PCS/UMTS bands while its MIMO antenna system operates in 4th and 17th bands of LTE. The proposed antenna consists of meandered patch planar inverted F-antennas and branch lines. The radiation efficiency of proposed

antenna is more than 30% in LTE bands and more than 40% in DCS/PCS/UMTS bands. The ECC between different antenna elements is less than 0.5 over the entire targeted frequency bands. High isolation between antenna elements (> 8 dB) is obtained.

Ahmed et.al in [10] develops a compact planar multiband MIMO antenna system. Antenna has a total size of $100 \times 50 \times 0.8$ mm³. Antenna fabricated on FR-4 substrate ($\epsilon_r=4.6$, thickness=0.8 mm, $\tan(\delta) = 0.02$) of dimension 110×60 mm². MIMO antenna system consists of two symmetric antenna elements. Each of which comprises three effective radiators: a driven monopole, a meandered S- and F- shaped strip. At $VSWR \leq 2.75$, antenna operates in frequency range of LTE-1, LTE-2, LTE-3, LTE-7, LTE-40, and WLAN 2.4 GHz bands. Higher isolation (>18 dB) is achieved. The correlation coefficient is lower than 0.01.

Rao and Wilson in [11] presented a multiband diversity antenna and achievement of size efficiency of antenna in wireless terminals. The proposed antenna have two folded edges for the rectangular patch. The variation in patch width can result in frequency re-configurability and frequency tuning can be obtained. The antenna has ground plane dimensions of 5.5 cm X 10.5 cm. The substrate used in the proposed antenna is FR4 with dielectric constant 4.4 and thickness 1 mm. The conducting patch is kept on substrate. The overall dimensions of proposed antenna are 0.7 cm X 1.5 cm X 0.75 cm. Author claims the mutual coupling between diversity element below 10 dB at both lower and higher frequency bands. The ECC value is calculated for both bands and claimed to lie below 0.7 at all frequency bands.

Shoaib et.al in [12] study and design a linearly polarized compact multiband MIMO antenna. In the proposed design size compactness is targeted for small size wireless terminals. The MIMO diversity is obtained by arranging two antenna elements at the distance. The antenna elements are printed monopole patch antennas. The antenna elements are separated by $0.097 \lambda_0$ when the frequency of operation is 900 MHz. The antenna elements are fed by capacitive type of twisted line feeding. A parasitic loop and shorting trip is used for generation of resonances at 900 MHz, 1.8, 2.1, 3.50 and 5.4 GHz bands. The isolation between antenna elements in proposed design is 15 dB and 20dB for lower and upper bands respectively. The ECC has been calculated for the designs and found to be less than 0.025 in the desired bands of operation.

Zhao and Choi in [13] proposes a multiband MIMO antenna for 4G mobile terminal. The antenna structure consists of multiband main antenna element, a printed inverted-L sub-antenna element and a wideband loop sub-antenna. To improve isolation and ECC, each element is located at a different corner of ground plane. Inductive coils are used reduce the antenna volume. Proposed antenna covers LTE band 7/8, PCS, WiMAX and WLAN service simultaneously. MIMO antenna has ECC lower than 0.15 and isolation higher than 12 dB in both lower and higher bands.

Ren in [14] presented a compact multiband antenna for handset and tablet application. This study uses a ceramic material which gives a shorter guided wavelength and wider bandwidth to achieve antenna size reduction and very low correlation coefficient. Antenna radiator occupies a volume of 35 X 11 X 5 mm³.

Miers et.al in [15] design a bandwidth enhanced and multiband MIMO antennas using characteristics mode. By correlating the characteristic currents and near fields of modes with high modal significance in a given frequency band, a single feed may be designed to excite multiple modes, leading to enlarged bandwidth. Similarly, the correlation of characteristic currents and near fields across different bands provides candidate modes that can be excited for multiband operation using a single feed. Moreover, the impedance matching of these modes can be improved by additional structural manipulation.

In [16], author proposes a compact UWB MIMO antenna covering entire Ultra Wideband (3.1-10.6 GHz). In order to improve isolation, isolating metal strip is introduce between radiating elements. The proposed antenna provide an isolation better than 20 dB, ECC less than or equal to 0.1641 and peak efficiency of 90%.

Liu et.al in [17] proposes a compact MIMO antenna for portable UWB devices. The size of propose antenna is 26 x 40 mm² and designed on a Rogers substrate, RO4350B having a thickness of 0.8 mm, a loss tangent of 0.004 and permittivity of 3.5. The author employs two planar monopoles placed perpendicularly to each other to get good isolation between input ports. To enhance isolation, two ground stubs are placed adjacent to radiating elements and a short ground strip that connects the two ground planes together are used. The author observes

mutual coupling of less than -15db and ECC of less than 0.2 across UWB for the proposed design.

Many studies have been made to improve isolation, to reduce correlation between radiating elements. In [18], a compact dual port MIMO array antenna for mobile handset is introduced. The introduced antenna works at a frequency band of 2.4 GHz-2.84 GHz. The quarter wavelength antennas are used as radiating elements and between two antenna elements a meander shape slot has been used to provide isolation. The author claims that the proposed design has advantages over other isolating slot structures in terms of isolation, efficiency, diversity performance and bandwidth.

In [19], quad band MIMO array antenna has been presented. The proposed antenna array operates at frequency bands of 2.4–2.5 GHz, 3.4–3.6 GHz, 5.15–5.35 GHz, and 5.75–5.875 GHz. The design of quad-band MIMO array uses a two slots and a resonator to operate in the specified quad-band while maintaining isolation characteristics. C-shaped slot is cut in patch to get resonances at 2.45 and 5.75 GHz frequency bands. The T-shaped slit in the antenna to get another resonance at 5.2 GHz and in order to get the fourth band a resonator with matching element is added to the antenna.

Browne et.al in [20] design a compact antenna array for MIMO system. PIFA design is propose for use as a basic element to build compact array. Compact two element and four element PIFA array is design for use in MIMO portable devices. The volume occupied by the array is two element array is $0.45 \lambda \times 0.12 \lambda \times 0.033 \lambda$ and volume occupied by four element array is $0.45 \lambda \times 0.12 \lambda \times 0.066 \lambda$. The substrate use to design both two elements and four elements array is RT-Duroid. The authors observes that as number of radiating elements increases from two to four, detrimental effect of mutual coupling on array efficiency compounds.

In [21], triband PIFA array is design for MIMO radio communication. The design uses two slits to realize three resonant modes and provide low mutual coupling between array elements.

In [22], capacitive fed microstrip antenna for wideband application is presented. Capacitive feed is created by a slot cut within the rectangular patch around the feed point. The proposed

antenna reveals a much higher impedance bandwidth of about 47% ($S_{11} < -10$ dB). The author discuss the effect of air gap between the substrate and the ground plane.

In [23], author proposes a novel dual band MIMO array for portable wireless devices. The MIMO antenna array occupies a volume of $15 \times 50 \times 0.8$ mm³ and two monopoles elements are placed back to back with edge-to-edge separation of 0.096λ . The antenna is design on FR4 substrate with relative permittivity of 4.4. The author designs a shorting strip and isolation stub to reduce mutual coupling between two radiating elements. The correlation coefficient of the proposed MIMO antenna is less than 0.01.

In [24], author proposes a compact MIMO printed array antenna. The propose antenna design consists of an array of five elements and then these two arrays are employed for MIMO application. The antenna is design on FR4 substrate with relative permittivity of 4.4, thickness of 1.588 and Loss tangent of .001 and antenna works at frequency of 5.25 GHz. The proposed antenna offers high gain, good impedance matching and a band width of 150 MHz Isolation achieved by this design is -25dB by adjusting the distance between two arrays.

Yang et.al in [25] proposes a dual band MIMO antenna array for ultra-wideband (UWB) operations. The antenna consist of a notch in UWB bands and array consist of two planar printed antenna array elements. The antenna is fed by CPW feed of 50 ohm impedance. The mutual coupling between antenna elements is reduced by using the central metallic strip between proposed antenna elements. The isolation parameter is analyzed for the proposed design and found to be less than -30 dB.

Piazza et.al in [26] designs a reconfigurable antenna array for MIMO system. The propose antenna system consists of two printed dipoles to create an array separated by quarter wavelength distance. Each array element length can be reconfigured using PIN diode switches. Though switch configuration is explicitly defined to effect the correlation between array antenna elements. The use of switches are also supposed to effect the radiation properties of the antenna. This leads to different degree of pattern diversity and this concept is use by author to improve link capacity. Author claims that an average improvement in link capacity achieve

is 10% and 8% for SNR of 10 dB and 20 dB respectively as comparison to non-configurable antenna arrays system.

Abdalla in [27] presents a two element array antenna with reduced effect of surface wave and mutual coupling. In order to reduce mutual coupling, author uses an electromagnetic bandgap (EBG) structure between the two elements of the array antenna and a defected ground structure between the two antennas. Upon testing DGS individually shows 12 dB reduction in transmission coefficient, EBG shows 15dB reduction in transmission coefficient. When both DGS and EBG tested together shows 22dB reduction in transmission coefficient.

In [28], authors designed a compact multiband array antenna for MIMO application. The proposed antenna is designed on Rogers RT/duroid 6002 substrate of dimension $W \times L = 50\text{mm} \times 70\text{mm}$ and thickness 1.6 mm. The proposed system operates in frequency bands of 1710-2200 MHz and 5150-5350 MHz which covers DCS, PCS, UMTS and HIPERLAN2 applications. The proposed antenna offers numerous advantages such as size efficiency, simple structure, compatibility, low cost and good radiation patterns.

Nezhad and Hassani in [29] presented a novel multiband monopole antenna of E shaped for MIMO applications. The presented antenna suitable for frequency of 2.4, 5.4, and 5.8 GHz. The substrate used for the presented antenna has a permittivity of 2.2, thickness 0.8mm, and dimension of $35 \times 38\text{mm}^2$. The ECC offered by the configuration is below 0.02, efficiency of higher than 90%, and stable omnidirectional patterns at all three frequency bands.

2.1 Research Gap

- i. In the literature, the antennas are proposed for wide-bandwidth, multi-bandwidth and desired directivity of the antenna. But the antenna size is always bottleneck in achieving compactness of the devices, which is not specifically targeted or explained in much of the papers.
- ii. The techniques introduced in the literature offer effectiveness in terms of size, bandwidth and gain but the terms are not optimized as per the conventional principles in antenna.

- iii. The antennas introduced for MIMO can be effectively design by optimization using principle of pattern multiplications.
- iv. The small size MIMO antenna is not discussed in the existing literature, the compactness in MIMO-PIFA need to be explored.

2.2 Objectives for the thesis

The thesis has been organized with four objectives given as

- i. To analyze different structures of planar antennas using EM software.
- ii. To study conventional principles in antenna design and their applications.
- iii. To propose size reduction techniques for achievement of small size in mobile phone antennas.
- iv. To propose planar antennas for MIMO operations in next generation wireless systems.

2.3 Methodology

1. The thesis started with study of antenna design and modern day wireless systems requirement.
2. The different antenna structures are simulated using electromagnetic (EM) simulation software.
3. Parametric studies are carried out for the proposed designs.
4. Optimization of the proposed design parameters are achieved.
5. Different conventional principles in antennas are applied on antenna designs and presented in the thesis.
6. The comparison is to be made between different structure proposed in the designs in terms of S parameters, Gain, Current density, Isolation and Envelope correlation coefficient.
7. The results are to be verified with different type of parameters.
8. Communicating the results to journals.

Chapter 3

Electromagnetic principles and the parameters

3.1: Microstrip patch antenna computations

In this chapter the computation and the principles important for antenna design is presented. The design of microstrip patch antenna is governed by the flow chart shown in the figure 3.1. The input being frequency of resonance, relative dielectric constant and height of the substrate and the width and length can be evaluated on the basis of input.

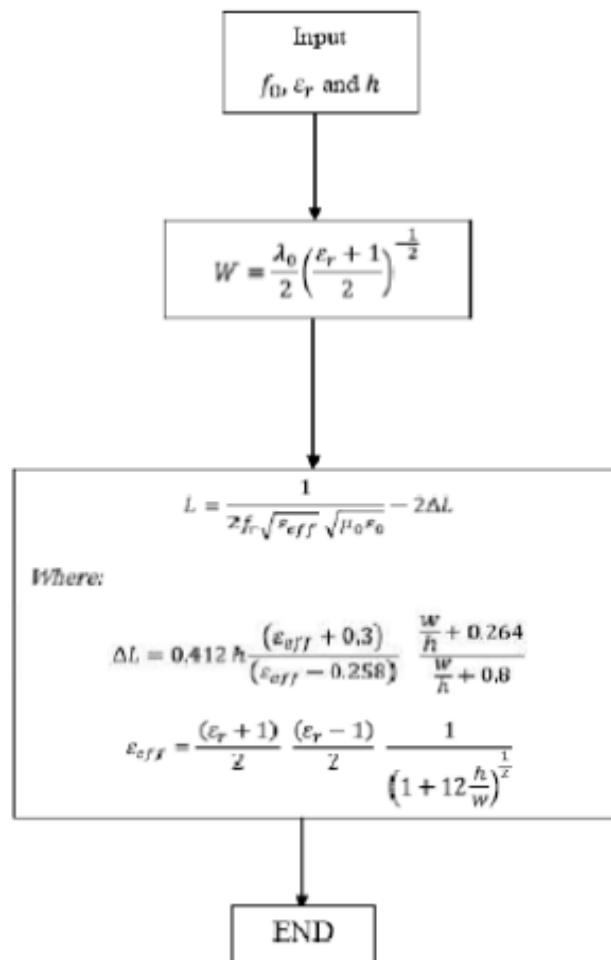

Figure 3.1: The flowchart for calculation of the microstrip patch antenna parameters

Along with the conventional antenna performance metrics and parameters such as the bandwidth, resonant frequency, the radiation patterns, the gain, the efficiency and several other important parameters need to be evaluated to fully characterize a MIMO antenna system. These metrics are not essential in single-antenna devices, but they are at-least essential for multi-antenna devices

3.2 Correlation Coefficient

The correlation Coefficient is a measure that describes how much the communication channels are isolated or correlated with each other. This metric considers the radiation pattern of antenna system, and describe how much the pattern from one antenna affect pattern from another when operated in MIMO systems. The square of correlation coefficient is known as envelope correlation coefficient. The envelope correlation coefficient can be calculated using following formula [30]

$$\rho_e = \frac{\left| \iint_{4\pi} \left[\vec{F}_1(\theta, \phi) * \vec{F}_2(\theta, \phi) \right] d\Omega \right|^2}{\iint_{4\pi} \left| \vec{F}_1(\theta, \phi) \right|^2 d\Omega \iint_{4\pi} \left| \vec{F}_2(\theta, \phi) \right|^2 d\Omega} \quad 3.1$$

The correlation coefficient can also be calculated using S-parameter. The calculation of correlation coefficient by S- parameter is more convenient than calculating it using radiation pattern. The significance of correlation coefficient is to analyze matching and isolation. The reflection coefficient calculation with S-parameter is defined as

$$\rho = \frac{|S_{11} \times S_{21} + S_{21} \times S_{22}|}{\left(1 - |S_{11}|^2 - |S_{21}|^2\right) \left(1 - |S_{22}|^2 - |S_{12}|^2\right)} \quad 3.2$$

The term S_{ij} is the scattering parameter from port j into port i.

The ideal value for ρ should be less than 0.7 for a mobile base station. Then for mobile terminals, the value for ρ should be less than 0.5. The guidelines for calculating the correlation

coefficient is that the antenna should be lossless, measurements should be made in a uniform scattering environment and the excitation of ports should follow the correct protocol.

3.3 Isolation

The terms coupling and isolation are generally used interchangeably in the literature as low coupling yields high isolation. More specifically, isolation is usually calculated directly from the S parameters (isolation = $-10\log_{10}(|S_{ij}|)$). Though the parameters isolation and correlation are different in some aspects. Lower coupling (high isolation) in general yields lower correlation, but it does not guarantee a low correlation coefficient, and vice versa. High isolation and low correlation coefficients are required for a MIMO antenna system to provide good diversity performance.

3.4 Total Active Reflection Coefficient (TARC)

To properly characterize the efficiency and bandwidth (BW) of the MIMO antenna system, the scattering matrix is not sufficient. The MIMO antenna system can better be characterized by the term total active reflection coefficient (TARC) is used. The TARC is defined as the ratio of the square root of the total reflected power divided by the square root of the total incident power [31] in a multi-port antenna system. The TARC can also be computed using the S parameters of the MIMO antenna system. For an N -element antenna, the TARC is given by

$$\Gamma_a^t = \frac{\sqrt{\sum_{i=1}^N |b_i|^2}}{\sqrt{\sum_{i=1}^N |a_i|^2}} \quad 3.3$$

Here a_i and b_i are the incident signals and reflected signals, respectively. The same can also be calculated using S parameters. The relationship between the incident and reflected waves in a multi-port network with similar characteristic impedances at all ports is given by [32]

$$\mathbf{b} = \mathbf{S}\mathbf{a} \quad 3.4$$

Where \mathbf{S} is the S -parameter matrix. The bold face in Equation 3.4 indicates a vector quantity with magnitude and phase. For an N -port MIMO antenna system, the S -parameter matrix will thus become $N \times N$ indexed matrix. The TARC accounts for coupling as well as random-signal combinations between ports. The TARC has a value between zero and one, where zero means all the power is radiated, while one means all incident power is reflected back and nothing is radiated. The available power is the sum of powers available on all the ports of the antenna system. The TARC is usually presented in decibels (dB).

The TARC also includes the effect of a feeding phase to the antenna port. A single curve of the TARC can hence be used to determine the resonance frequency and impedance bandwidth of the whole antenna system for a specified phase excitation between the ports. For a two-port MIMO antenna system, the TARC can be evaluated using:

$$\Gamma_a^t = \frac{\sqrt{\left(|S_{11} + S_{12}e^{j\theta}|^2\right) + \left(|S_{21} + S_{22}e^{j\theta}|^2\right)}}{\sqrt{2}} \quad 3.5$$

Where θ is the input feeding phase, S_{xx} is the reflection coefficient of the port, and S_{xy} is the coupling between the two ports associated with the antenna structure. Once the S parameters of a two-port network are found, the random phase is swept between 0° and 180° to investigate the effect of the phase variation between the two ports on the resonance behavior of the antenna, and to thus create the corresponding TARC curves for effective bandwidth assessment. If the TARC for a multi-port antenna system is needed for more than two ports, equation (3.5) is used in conjunction with Equation (3.4). Port 1 is excited with a signal having unity amplitude and zero phase, while the other ports are excited with similar amplitudes but different phases.

3.5 Mean Effective Gain (MEG)

The standalone antenna gain (i.e., the gain calculated for single antenna elements) is not a good measure of antenna performance, as the antenna is not to be used in an anechoic chamber but in practical applications. The antenna is used in a certain environment for a specific application. The study of the effect of the environment on the antenna's radiation characteristics is thus

important in evaluating its true performance. One way to do this is to fabricate an antenna, operate it under the specific conditions along with another standard antenna with known characteristics, and obtain the antenna's performance. The prototype of antenna is fabricated tests are performed to get the results, tune the antenna, and repeat the process to get the desired design. This procedure is very time consuming and costly. The mathematical expressions for the mean effective gain calculation is shown in Equations (3.6)

$$\text{MEG} = \int_0^{2\pi} \int_0^{\pi} \left[\frac{XPD}{1+XPD} G_{\theta}(\theta, \varphi) P_{\theta}(\theta, \varphi) + \frac{1}{1+XPD} G_{\varphi}(\theta, \varphi) P_{\varphi}(\theta, \varphi) \right] \sin \theta d\theta d\varphi \quad 3.6$$

where XPD is the cross-polarization power ratio or cross polarization discrimination, which represents the distribution of the incoming power (the ratio between the vertical mean incident power to the horizontal mean incident power), $G_{\theta}(\theta, \varphi)$ and $G_{\varphi}(\theta, \varphi)$ are antenna gain components, and $P_{\theta}(\theta, \varphi)$ and $P_{\varphi}(\theta, \varphi)$ represent the statistical distribution of the incoming waves in the environment, assuming that the two are not correlated.

3.6 Diversity Gain (DG)

Diversity is usually achieved when the transmitter receives multiple versions of the transmitted stream through different channel paths in context of MIMO systems.

If the signals are uncorrelated, the combined signals at the receiver will provide higher signal-to-noise-ratio levels, and thus better signal reception. Diversity gain is a measure of the effect of diversity on the communication system. Diversity gain (more specifically, the effective diversity gain) is defined as the difference between the time-averaged SNR of the combined signals within the diversity antenna system and that of a single antenna system in one diversity channel, provided the SNR is above a reference level. Mathematically, the diversity gain is defined as follows [33]:

$$\text{Diversity Gain} = \left[\frac{\Upsilon_c}{SNR_c} - \frac{\Upsilon_1}{SNR_1} \right]_{P(\Upsilon_0 < \Upsilon_0/SNR)} \quad 3.7$$

Where γ_c and SNR_c are the instantaneous and mean SNR for the diversity system, respectively, and γ_1 and SNR_1 are the instantaneous and mean SNR for the single branch with maximum values in the diversity system. $\gamma_{0, SNR}$ is the reference level.

3.7 Branch Power Ratio

Other factors that affect the performance of a MIMO antenna system are the relative power levels coming from the different antenna branches. The power levels of the various branches should be very close. To represent these power-level differences the two-branch power-level ratio (k) is introduced as

$$k = \frac{P_{\min}}{P_{\max}} \quad 3.8$$

Where P_{\min} is the power level of the antenna with the lower power, and P_{\max} is the power from the higher-power antenna. The power-level ratio will affect the diversity gain, as the overall obtained diversity gain is multiplied with the inverse of k to obtain the actual effective diversity gain.

3.8 Rumsey's Principle

In context of broadband antennas the most popular theory was introduced by V.H. Rumsey in 1950 and termed it as frequency independent antennas. The Rumsey's introduced the principle which need to be followed if frequency independence behavior is desired. According to Rumsey's principle "the impedance and pattern properties of an antenna will be frequency independent if the antenna shape is specified only in terms of angles". It is obvious from the statement of principle that if angle requirement need to be met, the length of antenna need to be infinite in length. Practically being impossible to configure antenna for infinite length, the antennas are usually truncated in size. But the size of frequency independent antennas usually require to be large size in terms of wavelength. The examples of frequency independent antenna includes spiral antennas, various log periodic antennas, sinuous antennas, and Dyson spirals etc.

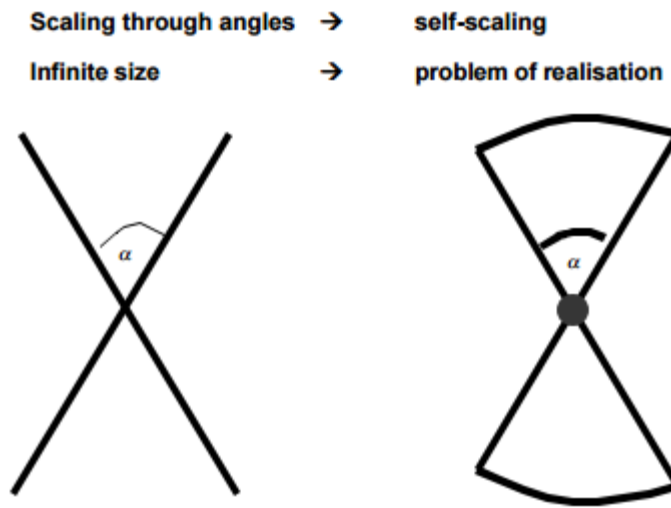

Figure 3.2: The structure following Rumsey's principle

This observation led to the suggestion that, if an antenna structure can be described entirely by angles without specifying any characteristic length dimensions, its pattern and impedance characteristics would be frequency independent

3.9 HCR Principle

The principle for frequency independent antenna was first presented by Rumsey [34] which defined conditions for antenna geometry to achieve frequency independence. The work was taken ahead by Hohlfeld and Cohen [35] in the context. The principle defined is termed as HCR principle and it is based on Maxwell's equation symmetry property.

In addition to the Rumsey's principle, the HCR principle defines the necessary and sufficient conditions for achieving frequency independence. The condition can be defined as to achieve the frequency independence, the radiating antenna should have self-similar structure as in case of fractal shapes and about a point the structure should be origin symmetric. The later condition defines the current distribution so, it may define the feed positions for the radiating structure. The log periodic and discone antennas are broad categories in self similar and point symmetric structures.

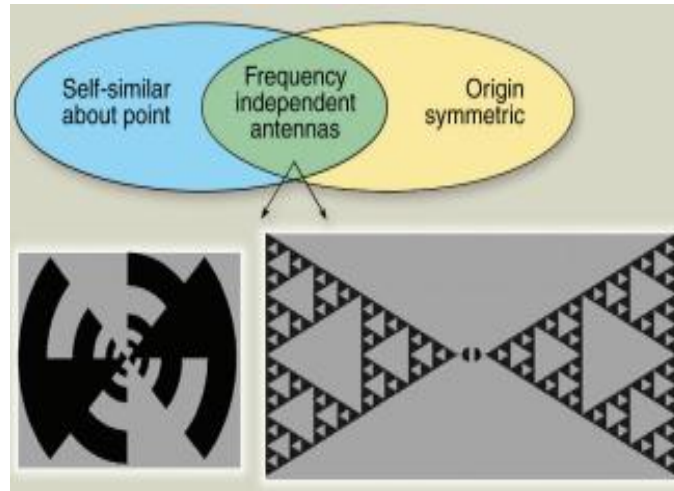

Fig 3.3: Hohlfield-Cohen-and-Rumsey (HCR) Conditions.

It is clear from the discussion so far that the Rumsey's principle is subset of the HCR principle. For a usual design of phased arrays, antenna element sizes and the distance between elements are chosen as fixed distances. This fixed distance between the elements is often nearly $\lambda/2$ at the highest operational frequency of the array in order not to observe the grating lobe at high frequencies. As a result, the elements can be electrically small at the low end of the frequency band for wideband applications. In conventional array design, the length of elements is determined according to the specified beamwidth at the lowest frequency whereas the element spacing is determined according to the wavelength at the highest frequency. This results in unnecessarily large number of elements at the lowest frequency for very wideband arrays. Moreover, the beamwidth at the highest frequency will be narrower than the specified value. If the phased array feed is frequency independent, the beamwidth of the array will decrease, and the gain will increase with increasing frequency. Thus, with conventional approach, wideband phased arrays are subject to disadvantages of frequency dependent radiation and high cost because of the large number of T/R modules required to feed the array. As a result, there is a need for a proper design of the array and the antenna feed so that the phased array can perform less frequency dependent radiation compared to a conventional phased array.

3.10 Capacitive Loading

In order to reduce the size of an antenna, different techniques are available in the literature. Few of them are listed here.

- (1) Capacitive loading
- (2) Inductive Loading
- (3) change of antenna's topology
- (4) Increase of the electrical length of an antenna

The electrical length of an antenna's can be reduced without changing its physical length by adding capacitor or inductor in series with it. This is called loading of an antenna. The loading of antenna can be achieved in patch antenna using different structures detailed in next chapter.

It is sometime desirable to use single antenna for both transmitter and receiver. Since transmitting and receiving antenna may need to operate at different frequencies, electric length need to alter for both roles of antenna. The answer is that electrical length can differ from physical length if it is loaded by capacitor or inductor. Moreover the size efficiency can be achieved using loading and the concept is used in proposed designs. If the antenna is too short for the wavelength being used, it is resonant at a higher frequency than that at which it is being excited.

3.11 Principle of pattern multiplications

The principle of pattern multiplications is important tool for obtaining radiation pattern from identical antenna array system. In few cases, the rough estimation of radiation pattern may suffice the need. The rough estimation of the pattern can be obtained from principle of pattern multiplications. With the help of the principle, any complicated array antenna pattern can be sketched rapidly.

According to the definition of principle of pattern multiplication

“The radiation pattern of an array is the product of the individual antenna with the array pattern”. The array pattern is a function of the position of the antennas in the array and their relative complex excitation amplitudes. Advantage of this method of multiplication is to sketch the radiation pattern of array antennas rapidly from the simple product of element pattern and array pattern. But this principle is applicable only for arrays containing identical elements.

$$\text{Total pattern} = \text{Unit pattern} * \text{Group pattern} \quad 3.9$$

Equation (3.9) is referred to as pattern multiplication for arrays of identical elements. Where the array factor is a function of the geometry of the array and the excitation phase. By varying the spacing (d) and/or the phase between the elements, the characteristics of the array factor and the total field of the array can be controlled.

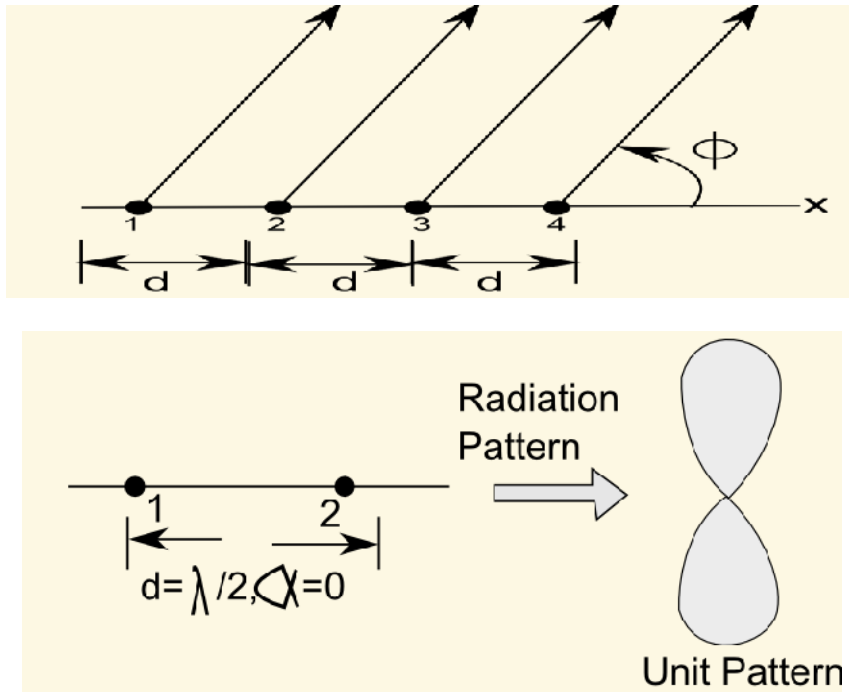
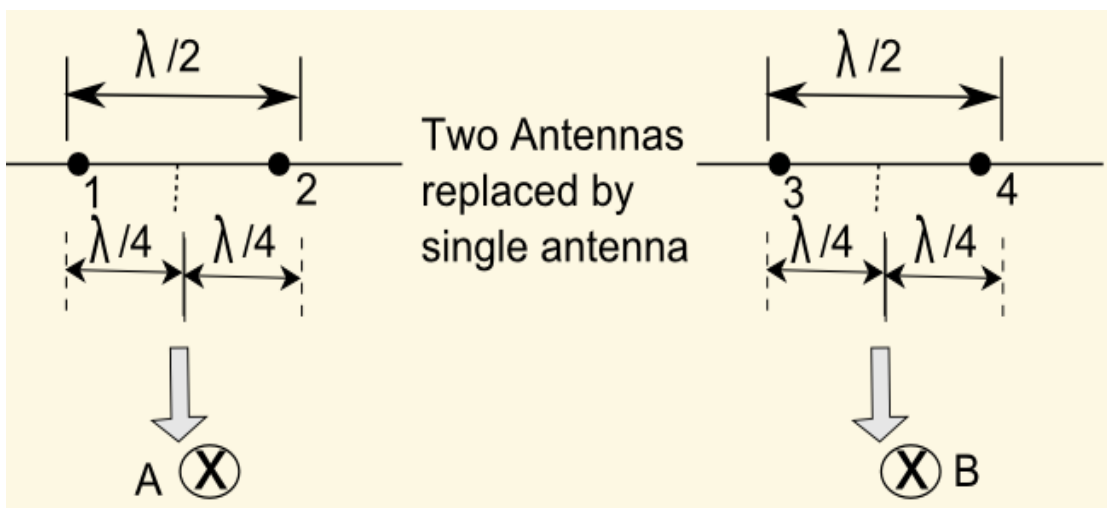

Figure 3.4: The principle of pattern multiplication for 2 antenna elements



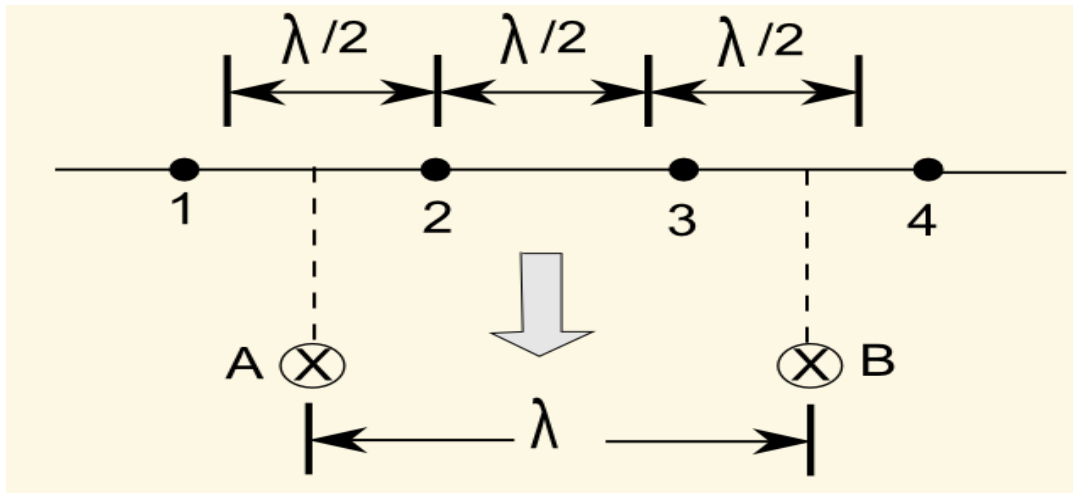

Figure 3.5: The principle of pattern multiplication for four element antennas array.

The example of radiation pattern estimation by principle of pattern multiplication is shown in figure 3.4 (a). The example considers two identical antenna element separated by $\lambda/2$ spacing are replaced by single antenna element. The radiation pattern of the antenna array is obtained by the multiplication of antenna element pattern with that of array factor as shown in the figure 3.4 (b). The radiation pattern obtained from 2 antenna element array is used for evaluation of the pattern for 4 element array. The 2 antenna element array is considered as single element with the radiation pattern defined in the figure 3.4 (b).

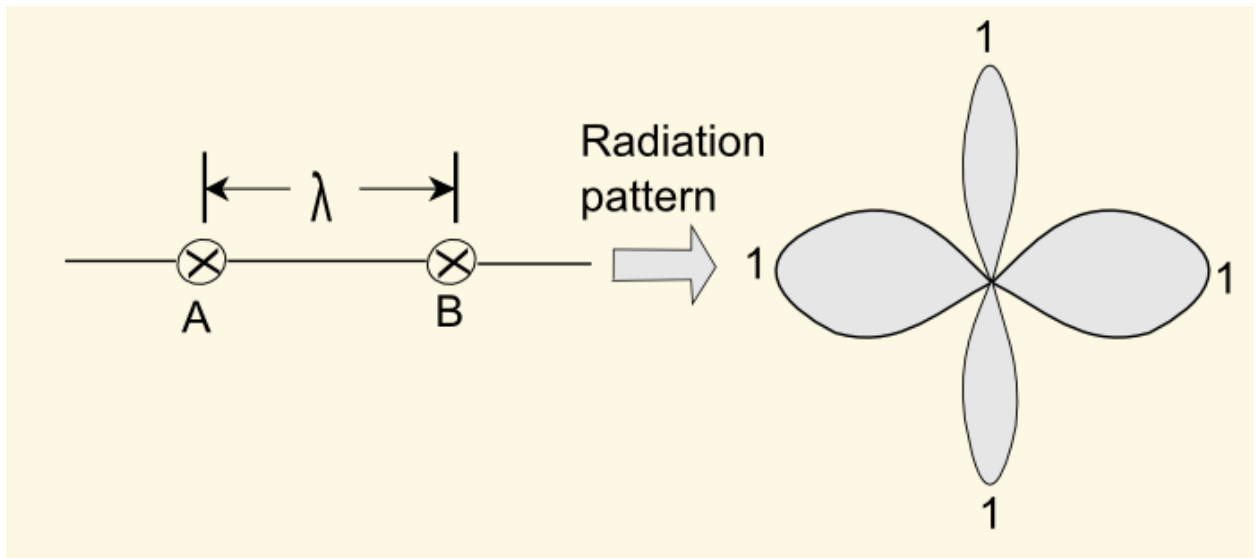

Figure 3.6: The final pattern for 4 element antenna array

The final pattern for 4 element antenna array is evaluated in the figure 3.6. where the multiplication of equivalent of two antenna elements array and array factor is performed. The final pattern from principle of pattern multiplication is depicted in figure 3.6.

Chapter 4

Results and Discussion

4.1 Basic designs

4.1.1 Design of Inset fed microstrip patch antenna

This section describe the design for microstrip patch antenna at desired frequency of 2.4 GHz to elaborate the evolution of MIMO antenna. The figure 4.1 (a) and (b) defines the rectangular patch microstrip antenna. The dimension of the patch is 28 mm X 28 mm. The connector chosen for the feed of the patch has 50 ohm impedance. The feed width is calculated for 50 ohm impedance. The 50 ohm impedance in figure 4.1 (a) does not match with edge of rectangular patch and shown in figure 4.2. The simple microstrip line feed width is 3.04 mm. The inset feed is used in figure 4.1 (b) instead of simply feeding microstrip line to the patch.

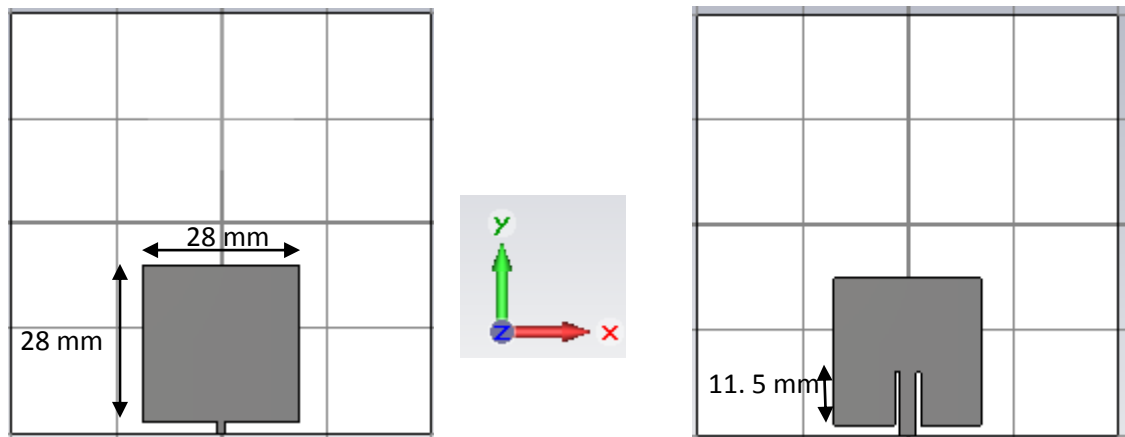

Figure 4.1: (a) The microstrip patch antenna with microstrip line feed (b) The microstrip patch antenna with inset feed.

4.1.2 Reflection Coefficient analysis of design

The S11 parameter for microstrip line feed without inset and with inset feed. The patch resonates at frequency define for WiFi i.e. 2.4 GHz as clear from the reflection coefficient shown in figure 4.2. The S11 below -10 dB is considered sufficient value of matching for the proposed antenna.

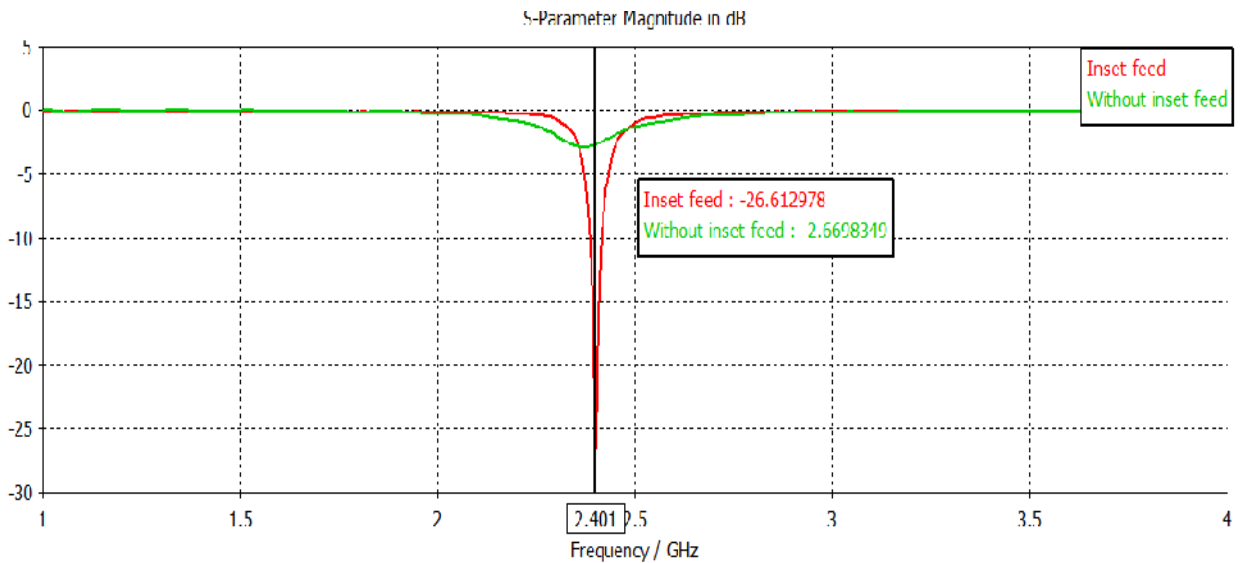

Figure 4.2: The S11 parameter for microstrip line feed without inset and with inset feed.

4.1.3 Current density analysis of design

The patch resonates in dominant mode TM₀₁ as proved by the current density shown in figure 4.3. The red mark shows the maximum current of 78.5 Ampere/ meter in the midway of y axis. The current remains constant along x axis. The behavior is specified for the TM₀₁ mode. In figure 4.3, the radiation pattern of proposed antenna is shown. The radiation pattern of proposed antenna is symmetrical along x axis. The proposed antenna radiates mostly in positive z- axis as defined by the radiation pattern.

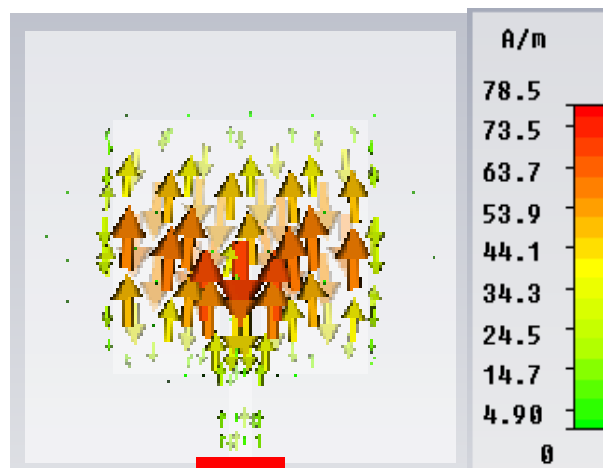

Figure 4.3: The current density of proposed antenna at 2.4 GHz

4.1.4 Radiation pattern analysis of design

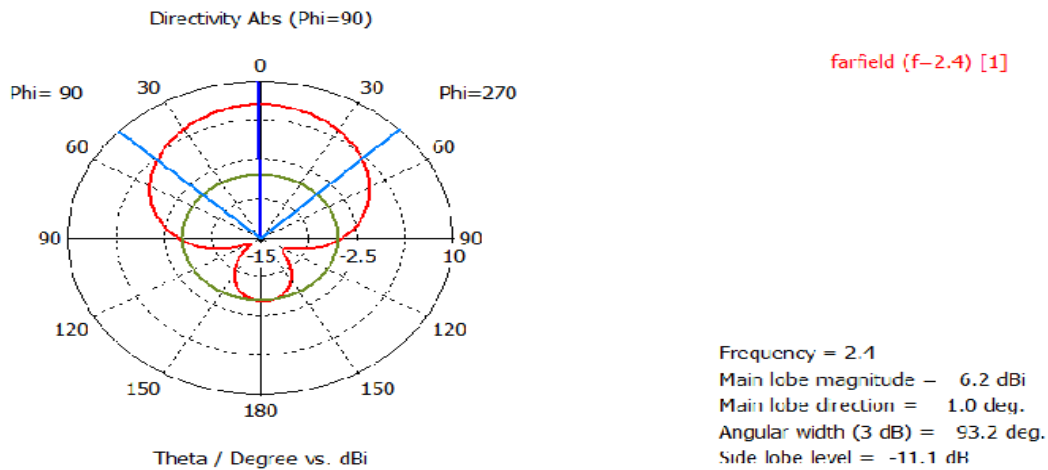

Figure 4.4: The radiation pattern of the inset fed antenna at frequency 2.4 GHz.

4.2 MIMO antennas

4.2.1 Design Considerations

In figure 4.4, the planar multiple input multiple output (MIMO) system consisting of 2 elements is proposed. The antenna elements have the dimensions of 30 mm X 30 mm. The antenna is designed on FR 4 substrate. The antenna elements are separated by the distance 18 mm in x – direction and 20 mm in y – direction. The antenna is considered as matched with 50 ohm impedance for the S11 below -10 dB and the isolation is considered satisfactory for below -20 dB.

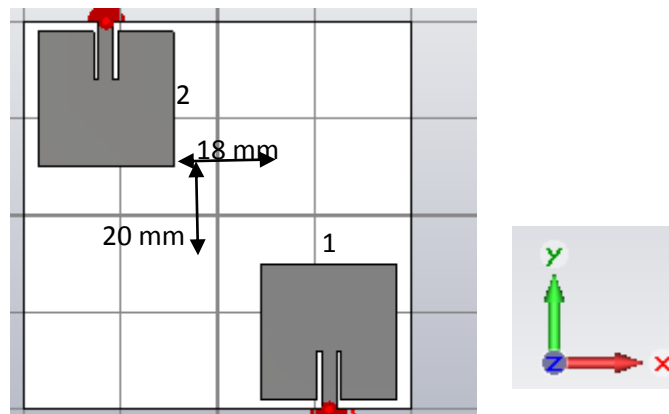

Figure 4.5: The MIMO system with two inset feed antenna elements

4.2.2 Reflection Coefficient analysis of design

The S parameters for the proposed system is shown in figure 4.5. The S11 parameter is reflection coefficient for the individual antenna elements and the S12 parameter defines the isolation between the antenna elements. The MIMO antenna so proposed in the figure 4.4 has good isolation so high spectral density which is the major consideration in modern day wireless systems. The MIMO antenna is planar so advantages of planar antennas are also enjoyed by the proposed system.

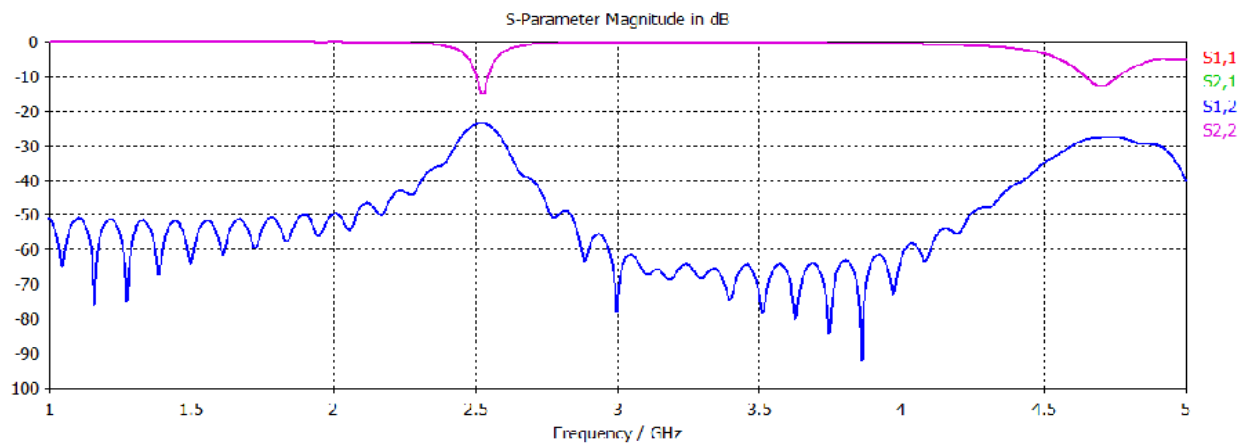
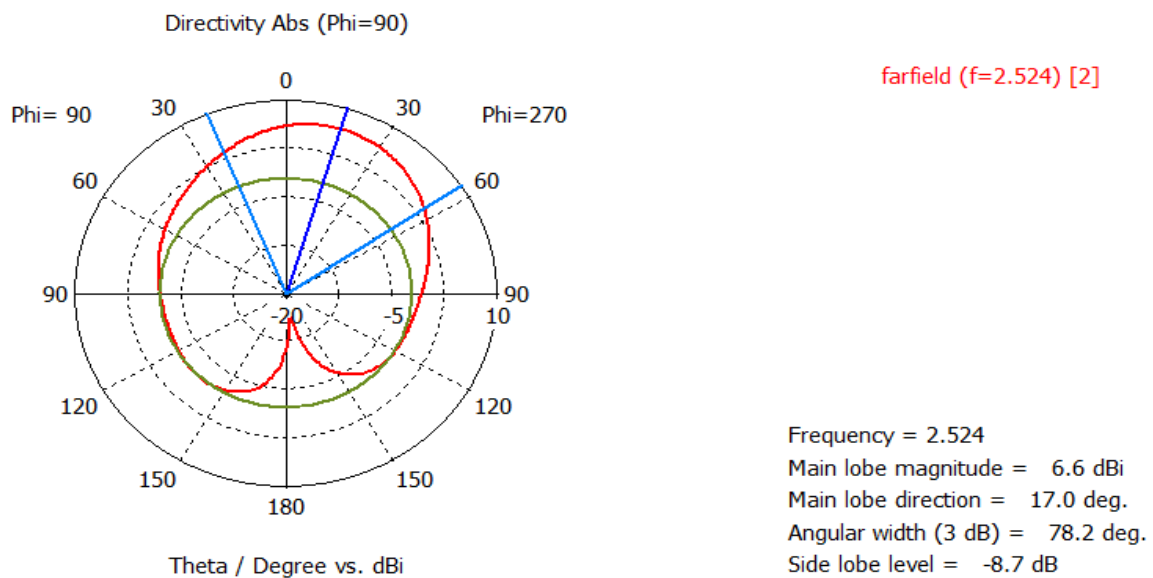

Figure 4.6: The S-parameters versus frequency for the proposed design

4.2.3 Radiation pattern analysis of design



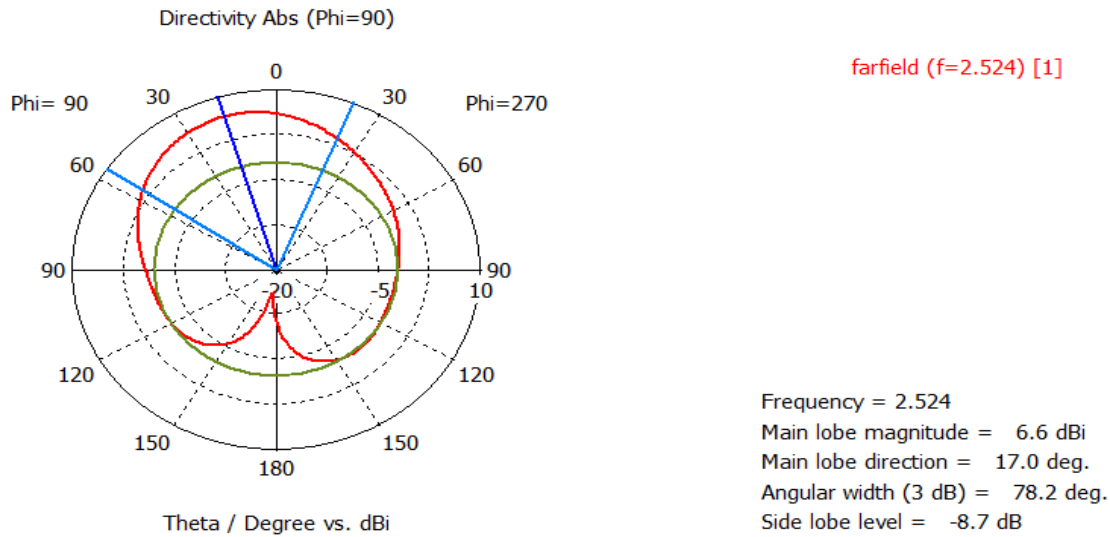

Figure 4.7 : The radiation pattern of proposed antenna at 2.52 GHz.

The radiation pattern of proposed antenna is shown in figure 4.7 for antenna 1 and antenna 2.

4.3 F-MIMO-PIFA Antenna for LTE/4G/WiFi

4.3.1 Introduction to proposed antenna.

As discussed in the preceding sections about need of small size antennas for mobile phones for next generation wireless standards like UMTS, LTE and Massive MIMO. The challenge is to achieve multiband operation and optimization of correlation at the same time. Another challenge is to achieve size efficiency for mobile phone applications. In this section, the PIFA antenna is presented for mobile phones. The multiband operation is achieved using HCR Principle L-shaped Koch fractal curve. The antenna consists of 2 elements with un-correlated patterns. The antenna is proposed for applications in MIMO wireless communication.

4.3.2 Design considerations

The design considerations in the section consider the design of element first and then the element is used in two antenna MIMO systems. The unit element of MIMO system is shown in figure 4.8. The 3-D prospective view of proposed antenna is shown in Figure 4.9. The antenna is termed as F-MIMO PIFA. The overall dimensions of proposed antenna are 25 mm X 25mm, which are the cross sectional dimensions. The patch is kept at height of 6.2 mm. The structural dimensions are optimized using neural network discussed in later sub-section.

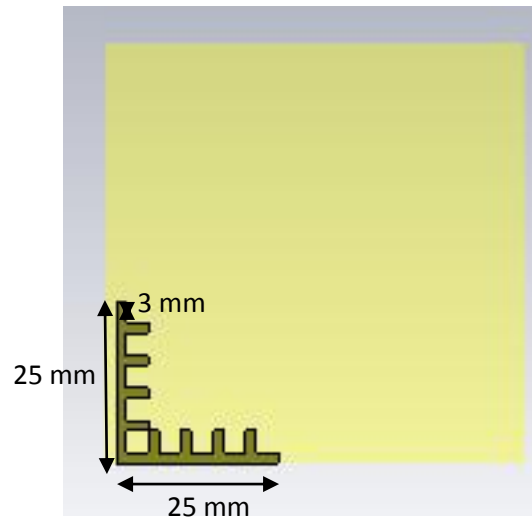

Fig. 4.8. Antenna Element of proposed MIMO

The air between patch and metallic ground behaves as substrate material with dielectric constant 1. The patch is shorted by strip of 5 mm width at 2.1 mm away from meeting corner of 1st iteration L-shaped fractal Koch curve. The antenna is fed by 6 mm strip, kept 3 mm away from meeting corner of L-shaped patch. The L-shaped 4 unit elements of 4 mm X 4 mm dimensions are combined in transverse directions to obtain 1st iteration of L-shaped patch. The different prospective views of proposed antenna is shown in figure 4.10.

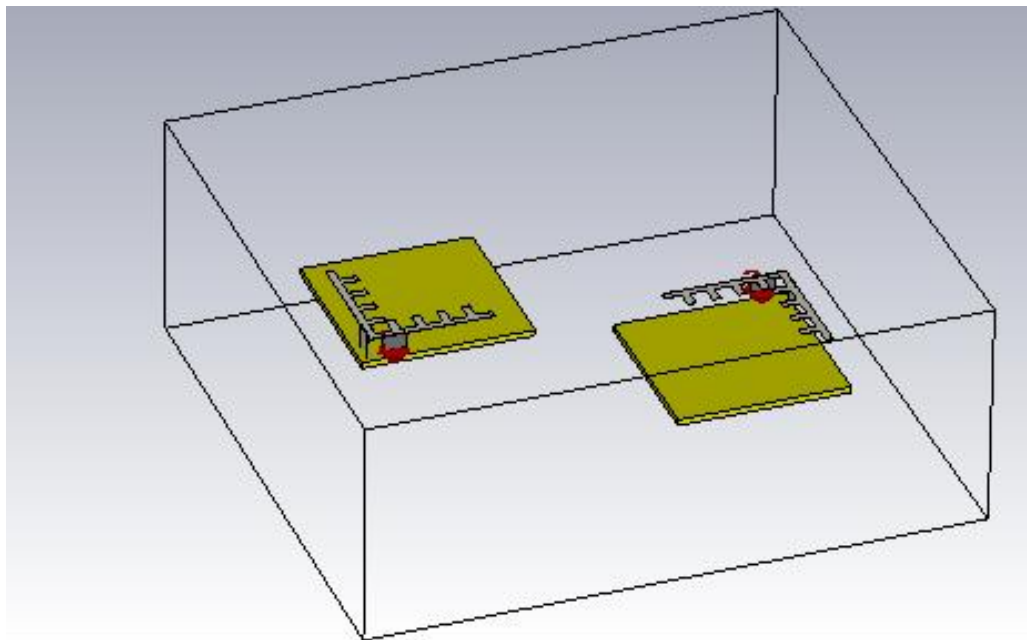

Fig. 4.9. The 3D view of proposed antenna

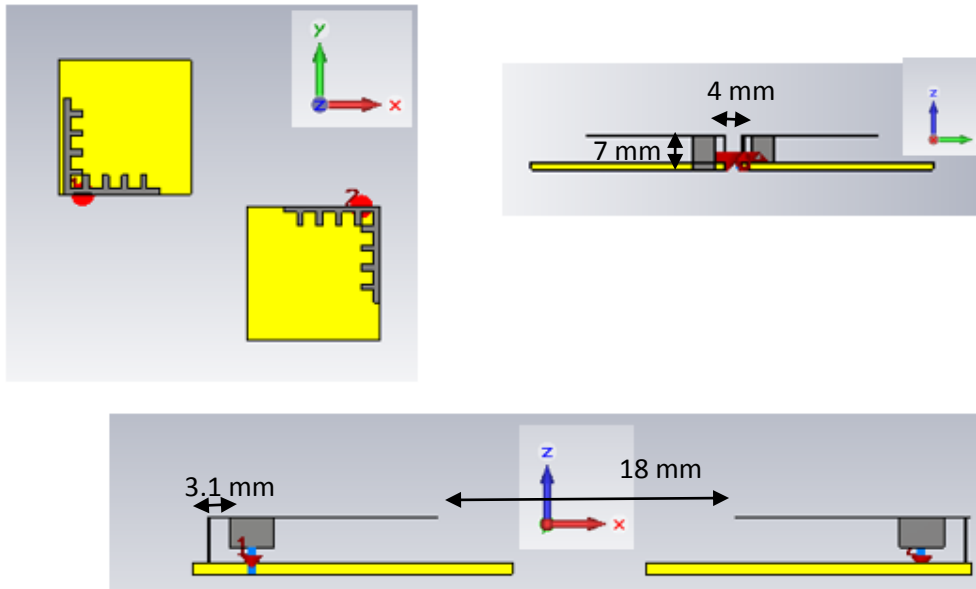

Fig. 4.10. Different prospective views of proposed antenna and detailed dimensions of antenna



Fig. 4.11 Fabrication of the proposed MIMO antenna system in comparison to Samsung 4.5 inch mobile phone.

4.3.3 Reflection Coefficient analysis of design

The parametric analysis of scattering parameters for the proposed design has been presented in the figure 4.12. The S_{11} (dB) is plotted for different feed locations. The current density path

shown in the next section explains the region for such a variation because of feed position. The feed position is selected to be 2.1 mm away from the L corner. The S11 for single antenna element with ground size of 50 mm X 50 mm is shown in figure 4.13. The antenna resonates at two frequency bands i.e. 1.84 GHz – 2.051 GHz for long term evolution (LTE) and 2.39 GHz- 2.44 GHz (WiFi) Band.

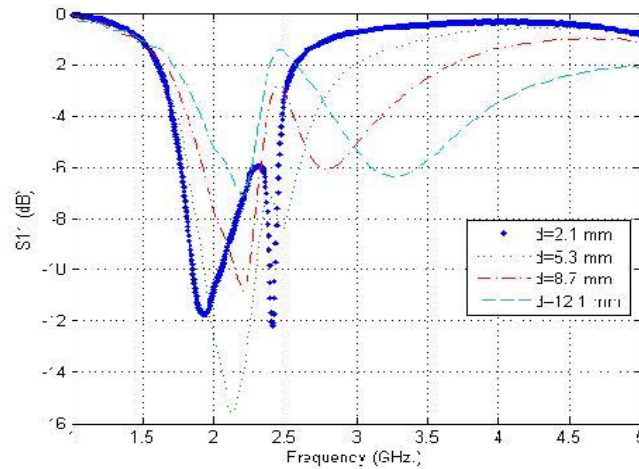

Fig. 4.12. Simulation and fabrication results for antenna

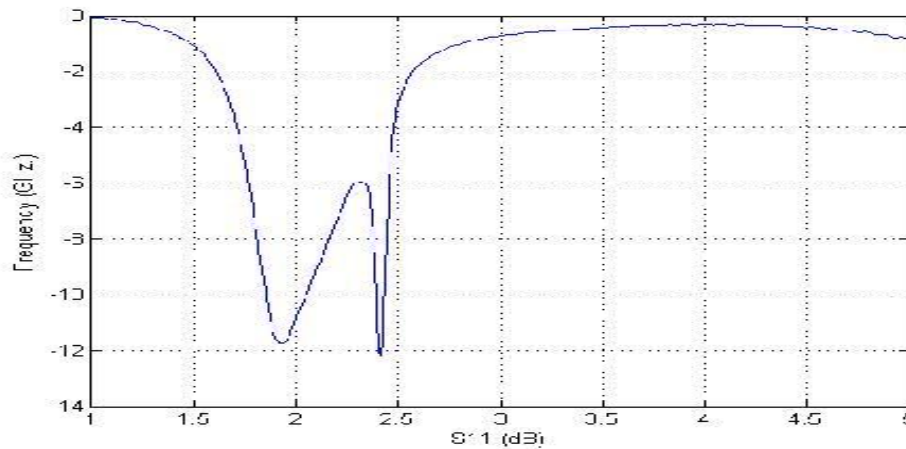

Figure 4.13: S11 (dB) for the proposed antenna element

The S11 and S21 in decibels for proposed MIMO antenna with 2 antenna elements is shown in figure 4.14. The antenna elements spacing is optimized for minimizing the correlation between two antenna elements as given by S21. When practical fabrication of antenna is

concerned. The patch can't be floated in the air, so the solid base is needed to support the patch mechanically. The material used for solid mechanical support must have similar dielectric properties as air. The thermocol which is easily available and exhibiting almost similar property to air is used as mechanical support to the patch of the antenna. The effect of solid support is analyzed through figure 4.14. The S11 parameter shows little variations in the result. This attribute to the use of thermocol to support the patch of the antenna mechanically without altering much the characteristics of the antennas.

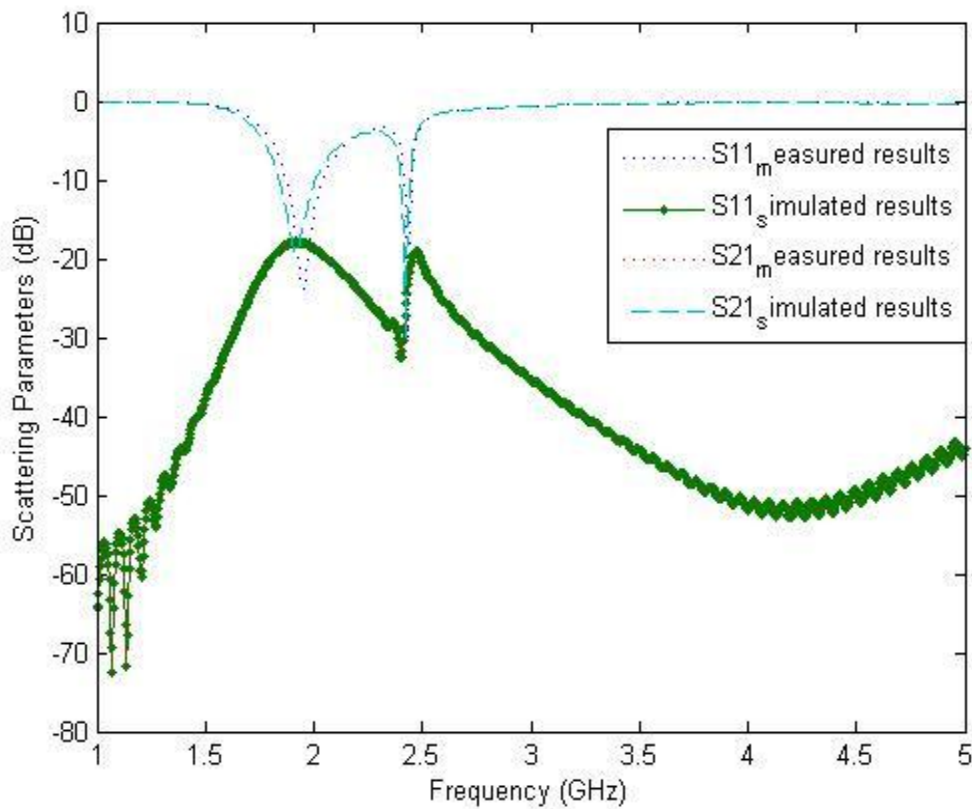
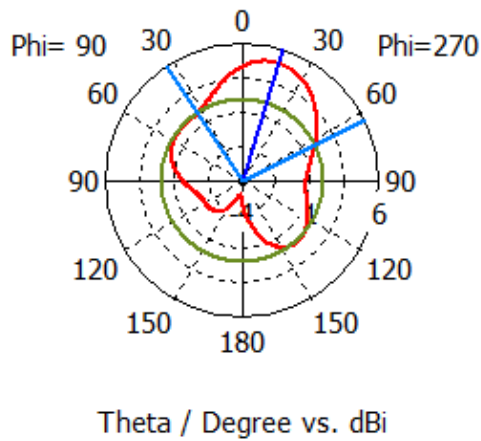

Figure 4.14: Comparison of simulated and measured results.

4.3.4 Field distribution

The field distribution of proposed antenna at 1.9 GHz and 2.4 GHz is shown in figure 4.15. It is clear from the figure that the fractal shape smaller element radiates at 2.4 GHz frequencies and the complete L resonates at the 1.9 GHz. Further the shorting pin contributes to resonant frequencies and the feed position decides two current path for the antenna. The first current

Farfield Directivity Abs (Phi=90)



Frequency = 2.4
 Main lobe magnitude = 4.93 dBi
 Main lobe direction = 17.0 deg.
 Angular width (3 dB) = 97.1 deg.
 Side lobe level = -3.0 dB

Figure 4.17: Radiation pattern of F- MIMO PIFA at (a) 1.9 GHz and (b) 2.4 GHz.

4.3.6 MIMO parameters characteristics for proposed design

The correlation between two antennas is analysed with parameter Envelope correlation coefficient (ECC). The frequency versus ECC graph is shown in figure 7. It is clear from Figure 7 that antenna correlation can be considered quite less as in frequency range 2.3GHz to 2.5 GHz, the value of ECC is less than 0.1 in both frequency bands.

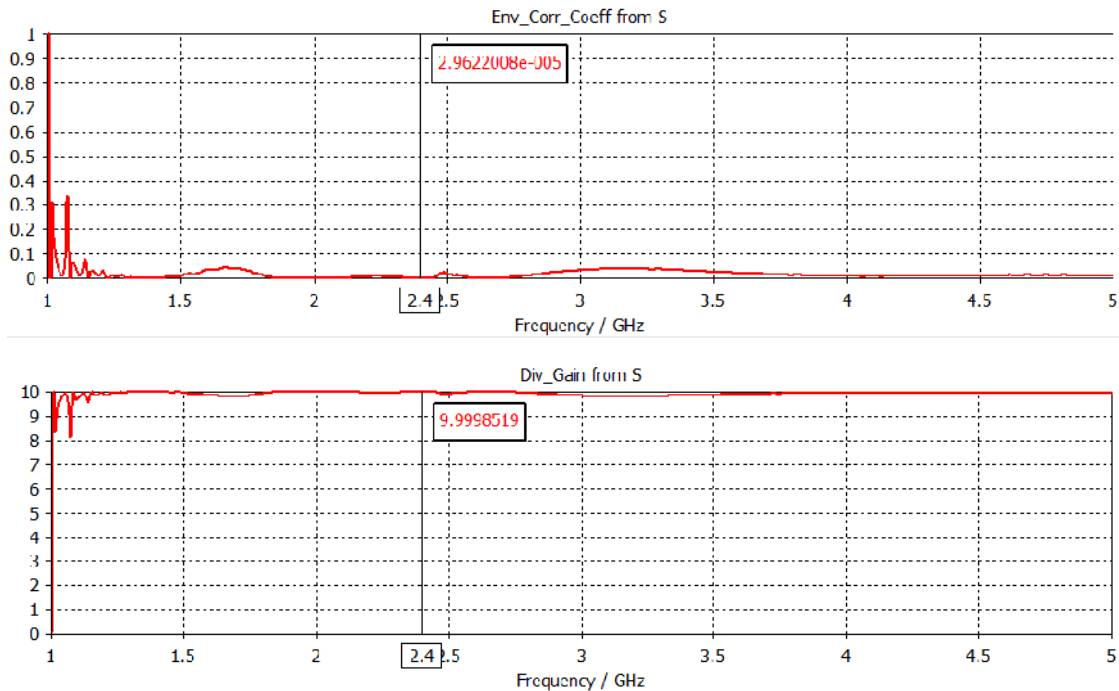

Fig. 4.18. ECC versus frequency (GHz) for proposed MIMO systems.

4.4. MU-MIMO

4.4.1 Introduction

The antenna proposed above in section 4.3 exhibits the property of MIMO and offers excellent mutual decoupling between antenna elements. The need for higher data rate in next generation wireless systems like 5 G, the multi-user MIMO is the need of an hour. The antenna is important component for 5G also known as Massive MIMO. The massive MIMO technique considers multi-user support by antenna using antenna arrays as an element of MIMO. The following section introduces the antenna for massive user MIMO system.

4.4.2 Design considerations

The proposed antenna is designed uses FR4 substrate with a dielectric constant of 4.4 and a thickness of 1.59 mm. The dimensions of the rectangular patch is 28 mm X 28 mm to achieve resonance at 2.4 GHz. The four element antennas are proposed in the design. The two antenna elements are targeted to behave like array and which in-terms behave like MIMO system antenna element. The inset feed is used to match 50 ohm connector impedance with that is of the patch. This type of feed is most commonly known as coupled feeds. This gap between patch and inset feed introduces a capacitance that cancels out inductance added by probe feed.

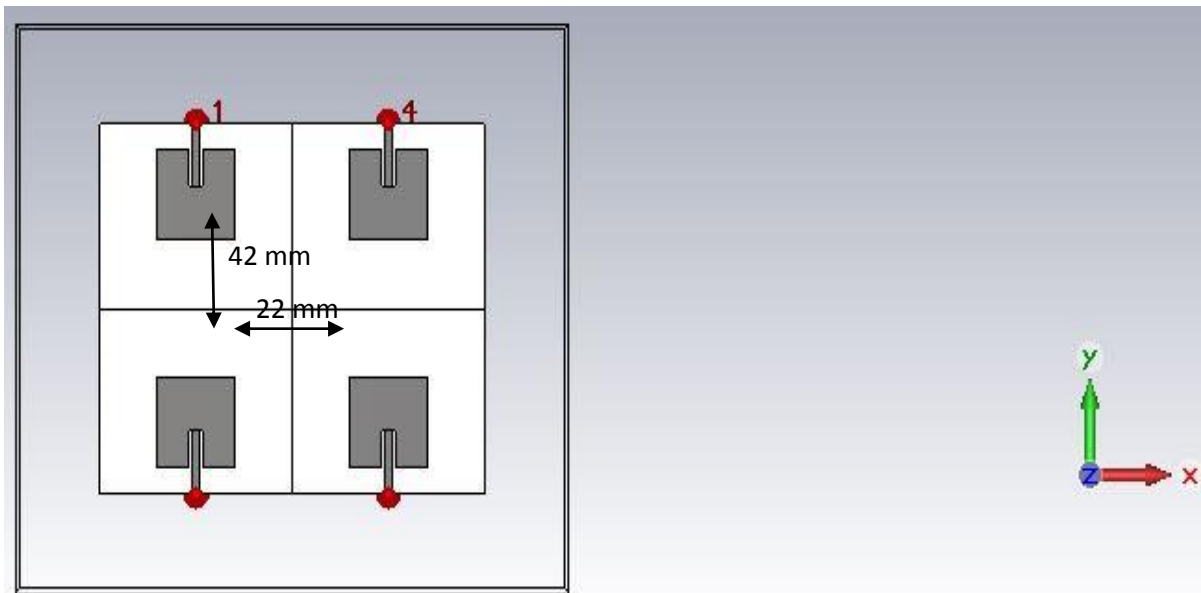

Figure 4.19: The MIMO system with four inset feed antenna elements

4.4.3 Reflection coefficient analysis of proposed design

The antennas 1 and 4 behaves like one antenna element and the combination of antennas 2 and 3 behaves like other antenna element. The reflection coefficient of each antenna is given in figure 4.20. It is clear from the scattering parameter graphs that the antenna resonates at the frequency ranges 2.44 GHz – 2.49 GHz.

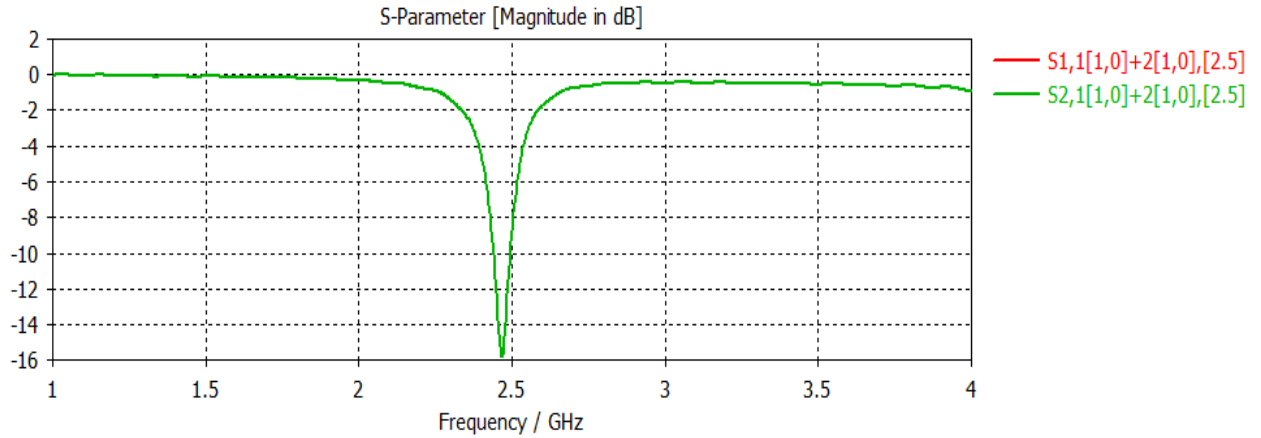

Figure 4.20: Reflection coefficient of each antenna element

The S_{11} and S_{21} for 2 antenna element as array and each array as MIMO antenna element is shown in figure 4.21. The S_{21} graph shows that the isolation between two MIMO elements are well below the specified limits of MIMO standards.

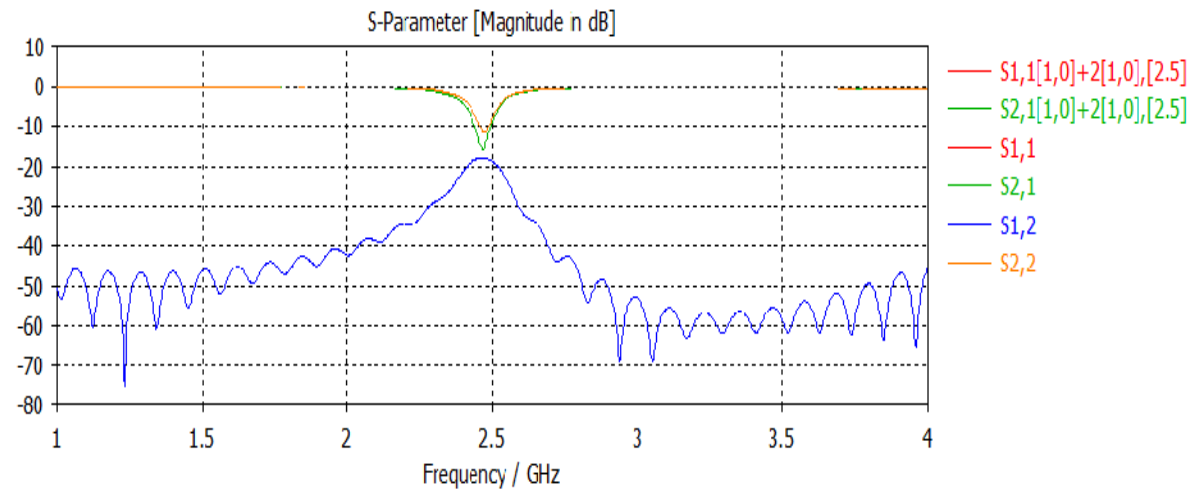

Fig. 4.21: S_{11} and S_{21} for 2 antenna array elements as single MIMO element.

4.4.4 Radiation pattern analysis of design

The radiation pattern of antenna array from element 1 and 4 is evaluated by principle of pattern multiplication and the pattern is used for obtaining optimized relative position for two antenna arrays in MIMO configurations.

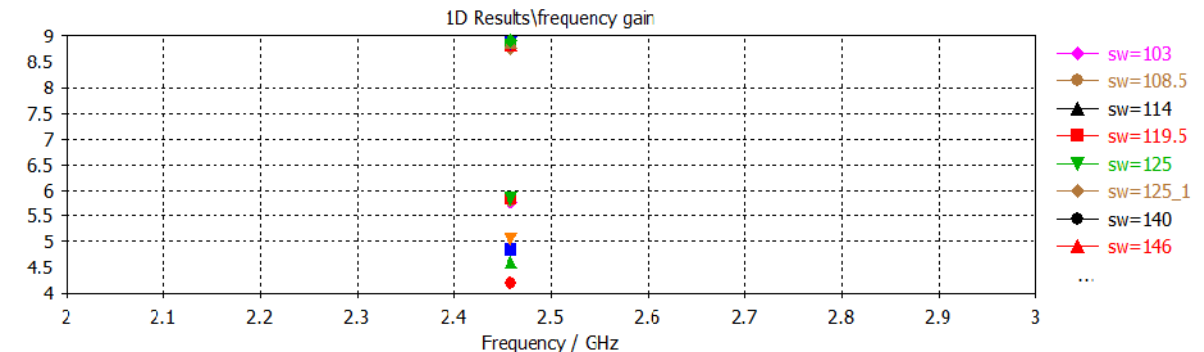

Fig. 4.22: Gain (dBi) versus frequency (GHz) for different values of antenna element spacing.

To optimize the value of gain for different spacing between antenna array elements is obtained. The different parameters versus antenna element spacing is shown in figure 4.22-figure 4.24. The optimization algorithm aims at maximizing gain, minimizing side lobe level and maximizing radiation efficiency. The high directivity of the antenna array results in decreased value of correlation between two MIMO elements.

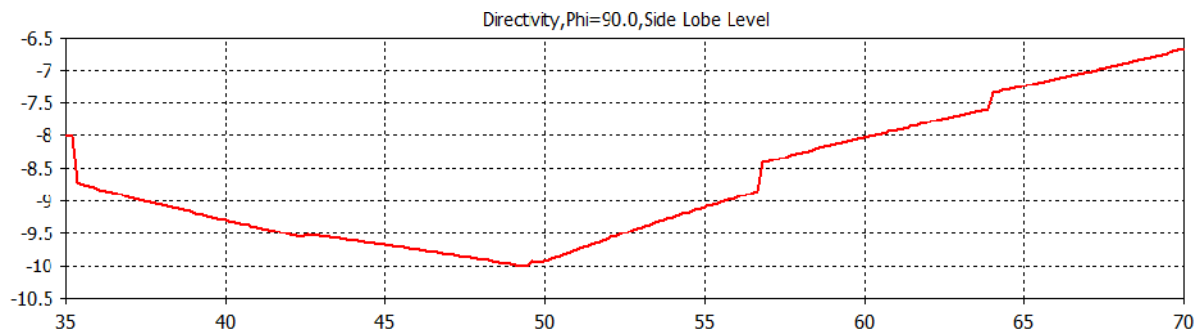

Fig. 4.23: The side lobe level (SLL) versus antenna element spacing

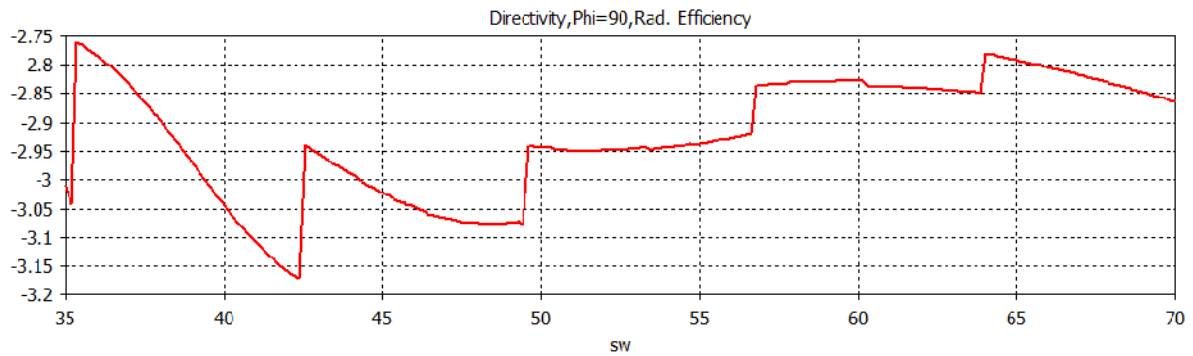

Fig. 4.24: The directivity versus antenna element spacing.

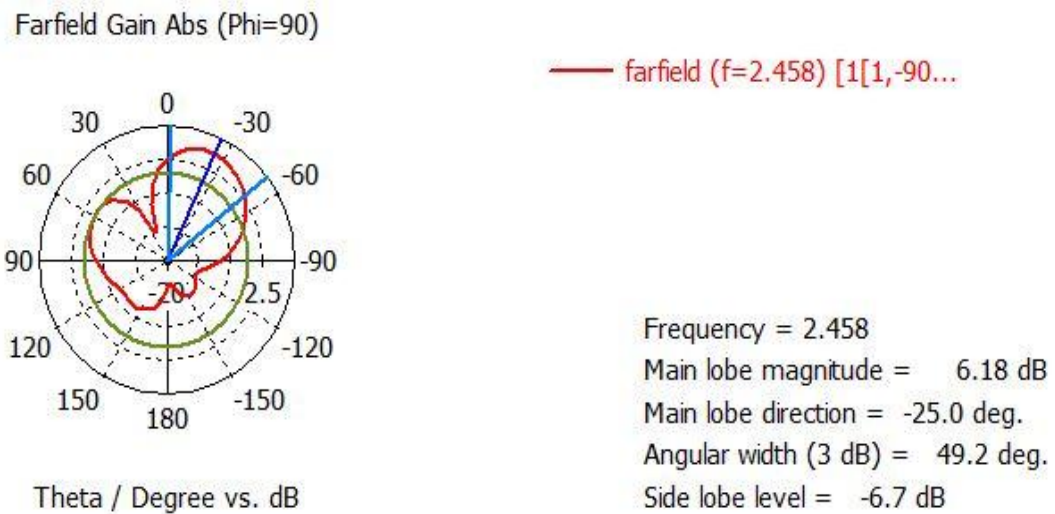

Fig. 4.25. Radiation pattern of proposed antenna

The radiation pattern for proposed antenna array from elements 1 and 4 is shown in figure 4.25. It is clear from the figure that the antenna radiates primarily in first quadrant of shown polar graph. The directive information helps optimizing MIMO parameters shown in next section.

4.4.5 MU-MIMO property analysis

Since system is proposed for multi-user MIMO communication, the MIMO properties are important consideration for the design. The two parameters are considered for evaluation of

MIMO system performance.

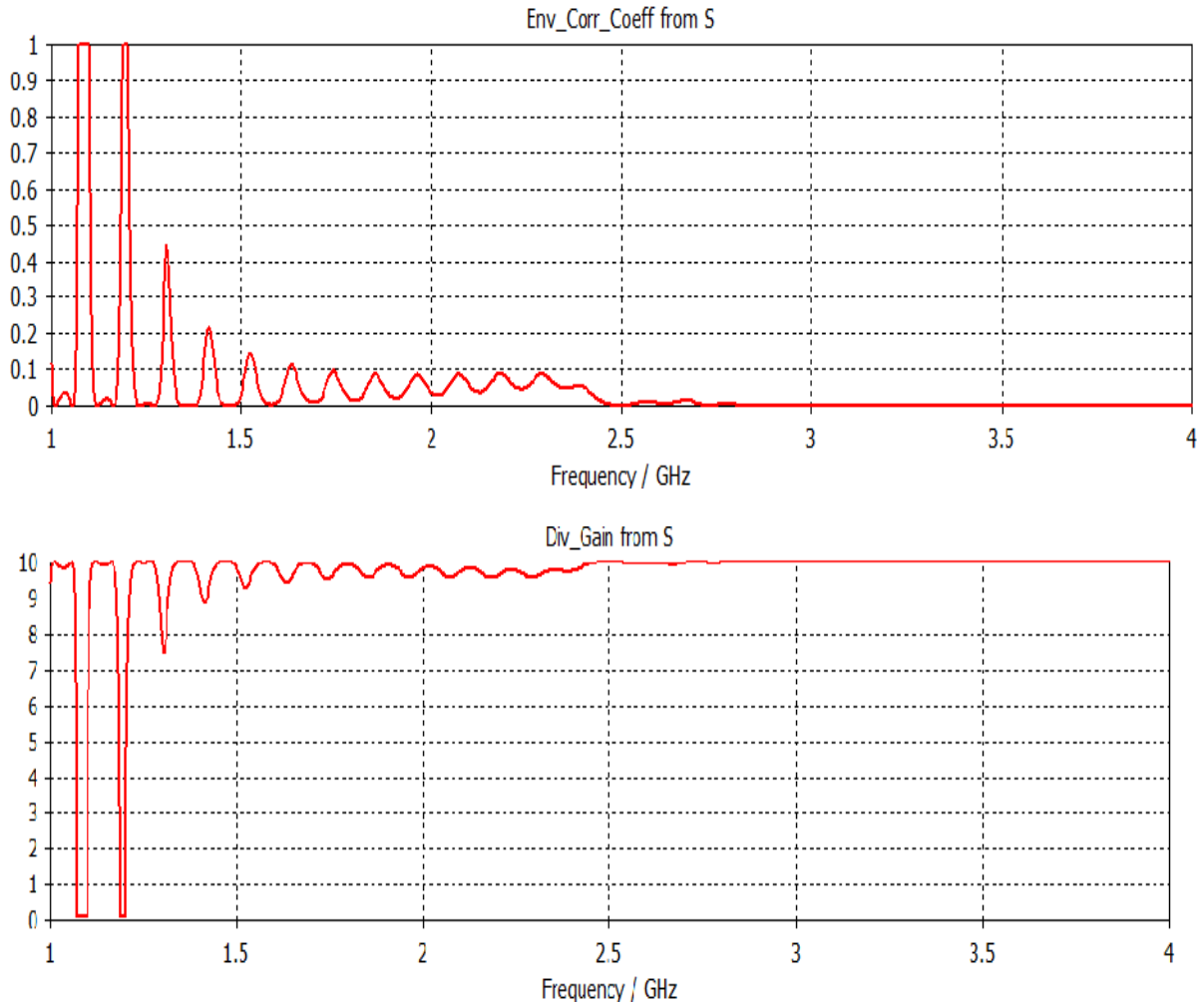

Figure 4.26 (a) ECC versus frequency and (b) Diversity gain versus frequency

The envelope correlation coefficient and diversity gain for the proposed design is shown in figure 4.26. Since the antenna is proposed to resonate at the frequency 2.45 GHz, the MIMO system offers ECC of less than 0.1 and diversity gain of more than 0.9, which is considered to be good performance for MIMO systems.

The proposed MIMO system is designed to operate for multi-user scenario as claimed to be covered in massive MIMO systems.

Chapter 5

Conclusion and Future Scope

5.1 Conclusion

The technology progress in this era of fast changing trends demands every component of the system to be precise. The electromagnetic principles available in the literature can contribute to the optimized design of the components in the context. The antenna is an important component of any wireless system and requires to be optimized as well. The increase in data rate demands for MIMO system to be employed. The antenna being important factor, the MIMO antenna is the need of modern day wireless systems for its advantage of spectrum efficiency and increase data rate. The MIMO antennas are well desired with planar structure. The thesis introduces the different concept of antennas and proceed with introduction to different aspect of MIMO antennas. Two approaches for MIMO antennas are defined such as spatial multiplexing and space time coding. The space time coding has channel matrix as important parameter. The transmitters in space time coding radiates equal power. The special performance criteria analysis are needed to carry out with some specific parameters like total active reflection coefficient (TARC), Envelope correlation coefficient (ECC), Mean effective gain and Branch power ratio etc. The literature survey is presented for the MIMO antennas. Authors have contributed lots of papers in context of MIMO antenna design.

The problem is formulated on the basis of research gap identified from the literature survey and the objectives are defined for the research to be carried out. The methodology based on parametric analysis, computation, optimization and testing is proposed in the thesis. The microstrip patch antenna with and without feed is presented. The inset feed helps matching the 50 ohm impedance microstrip line with the patch so that minimizes the reflected power to the microstrip feed. The current density is presented to prove the existence of dominant mode TM₀₁ at desired frequency of 2.4 GHz. The radiation pattern is also depicted to prove achievement of specific parameters for the desired application of Wi-Fi. The multiband MIMO antenna is proposed for the high data rate applications. The S parameters for the proposed design is presented and the proposed system offers resonance at 1.95 GHz and 2.4 GHz, which are the

spectrum allocated for LTE and WiFi. The radiation patterns at desired frequency is shown for the proposed MIMO system. The ECC and diversity gain performance is presented in the thesis for multiband F-MIMO antenna system. The reason for choosing L-shaped Koch fractal patch is verified by presenting field distribution of the antenna.

The second design is targeted for 5G wireless standard. The proposed antenna aims at achieving multi-user MIMO which can result in further enhancement of spectral efficiency. The design is discussed with different spacing between antenna elements. The rectangular shape is proposed in the design and fed by inset feed. The combination of the two antenna elements are behaving like antenna array and also behaving like individual element for MIMO operation of the antenna.

The conclusion is drawn that by applying conventional electromagnetic principles, the antennas can be designed for next generation wireless standards.

5.2 Future work

The antennas for next generation wireless standard currently aiming at multi-user MIMO implementations for achieving high data rate. The work presented in the thesis can provide basis to the future research. The concept of using conventional electromagnetic principles further can be considered for different designs. The antennas based on polarization diversity has further scope for implementation. The antennas for MU-MIMO with multiband support will be the future concern for the researchers.

REFERENCES:

- [1] A. Karabuto, Intel Developer Forum, Beijing, 2007.
- [2] Mpirical Limited, Boosting capacity with MIMO, 2010.
- [3] Seongcheol Lee, Jae Sik Kim, and Yoong Joong Yoon, “ Design of a Multiband Antenna with LTE B13 MIMO Characteristics in Mobile Handsets”, IEEE conference publications, pp. 507-510, 2012
- [4] Di WU, S.W. Cheung, T. I. Yuk and L. Liu, “Design of a printed multiband MIMO antenna”, IEEE conference publications, pp. 220-223, 2013
- [5] MinSeok Han and Jaehoon Choi, “Compact Multiband MIMO Antenna for Next Generation USB Dongle Application”, IEEE conference publications, pp. 1-4, 2010.
- [6] Aleksander Krewski, Werner L. Schroeder, and Klaus Solbach, “Multi-band 2-port MIMO LTE Antenna Design for Laptops Using Characteristic Modes”, pp. 1-4, 2012
- [7] Anup N. Kulkarni and Satish K. Sharma, “A Compact Multiband Antenna with Implementation for USB Size 4G LTE Wireless Devices”, IEEE conference publications, pp. 2215-2218, 2011
- [8] Atif Jamil, Mohd Zuki Yusoff, Noorhana Yahya, M. A. Zakariya, “Design and Performance Evaluation of Multiband MIMO Antennas”, IEEE conference publications, pp. 1-5, 2011
- [9] Bong-Gyu Shin, Chang Won Jung, Wonbin Hong and Juhyung Lee, “Diversity and MIMO antenna for multi-band mobile handset applications”, IEEE conference publications, pp. 419-421, 2011.
- [10] Foez Ahmed, Ronglin Li, and Ying Feng, “Development of a Compact Planar Multiband MIMO Antenna for 4G/LTE/WLAN Mobile Phone”, IEEE conference publications , VOL.1, pp. 539-542,2013
- [11] Qinjiang Rao and Kelce Wilson, “Design, Modeling, and Evaluation of a Multiband MIMO/Diversity Antenna System for Small Wireless Mobile Terminals”, IEEE journals and magazine, vol. 1, no.3, 2011

- [12] Sultan Shoaib, Imran Shoaib, Noshewan Shoaib, Xiaodong Chen and Clive G. Parini, "Design and Performance Study of a Dual-Element Multiband Printed Monopole Antenna Array for MIMO Terminals", IEEE journals and magazine, VOL. 13, pp. 329-332, 2014
- [13] Xing Zhao, Jaehoon Choi, "Multiband MIMO antenna for 4G Mobile Terminal", IEEE conference publications, pp. 49-51, 2013
- [14] Yu-Jiun Ren, "Ceramic Based Small LTE MIMO Handset Antenna", IEEE journals and magazine, VOL. 61, NO. 2, pp 934-938, 2013
- [15] Zachary Miers, Hui Li, and Buon Kiong Lau, "Design of Bandwidth-Enhanced and Multiband MIMO Antennas Using Characteristic modes", IEEE journals and magazine, VOL. 12, pp. 1696-1699, 2013
- [16] T. K. Roshna, U. Deepak, V. R. Sajitha, K. Vasudevan and P. Mohanan, "A Compact UWB MIMO Antenna With Reflector to Enhance Isolation," IEEE TRANSACTIONS ON ANTENNAS AND PROPAGATION, vol. 63, NO. 4, 2015, pp. 1873-1877.
- [17] L Liu, S. W. Cheung, and T. I. Yuk, "Compact MIMO antenna for portable devices in UWB applications," IEEE Trans. Antennas Propag., vol. 61, no. 8, pp. 4257-4264, 2013.
- [18] M. Ayatollahi, Q. Rao, and D. Wang, "A Compact, High Isolation and Wide Bandwidth Antenna Array for Long Term Evolution Wireless Devices," IEEE TRANSACTIONS ON ANTENNAS AND PROPAGATION, VOL. 60, NO. 10, pp. 4960-4963, 2012.
- [19] R.A. Bhatti, J.H. Choi, and S.O. Park, "Quad-Band MIMO Antenna Array for Portable Wireless Communications Terminals," IEEE ANTENNAS AND WIRELESS PROPAGATION LETTERS, VOL. 8 pp 129-132, 2009.
- [20] D. W. Browne, M. Manteghi, M. P. Fitz, and Y. R. Samii, "Experiments with compact antenna arrays for MIMO radio communications," *IEEE Trans. Antennas Propag.*, vol. 54, no. 11, 2006.
- [21] C. Calero, L. Gonzalez, and R. Martinez, "Tri-band compact antenna array for MIMO user mobile terminals at GSM 1800 and WLAN bands," *Microw. Opt. Tech. Lett.*, vol. 50, no. 7, 2008.

- [22] M. M. Fakharian, P. Rezaei, A. Azadi and M. R. Dadras, "A Capacitive Fed Microstrip Patch Antenna with Air Gap for Wideband Applications," *IJE Transaction*, Vol. 27, No. 5, pp. 715-722, 2014.
- [23] XueMing Ling and RongLin Li, "A Novel Dual-Band MIMO Antenna Array With Low Mutual Coupling for Portable Wireless Devices," *IEEE antennas and wireless propagation letters*, Vol. 10, pp. 1039-1042, 2011.
- [24] Chandan Kumar Ghosh, Bappaditya Mandal and Susanta Kumar Parui, "Omni-Directional Printed Antenna Array for MIMO Application," *International conference on computers and devices for Communication*, 2012.
- [25] Ying-Ying Yang, Qing-Xin Chu and Jian-Feng Li, "Dual Band-Notched Ultrawideband MIMO Antenna Array," **IEEE Conference Publications**, pp. 1-4, 2013.
- [26] Daniele Piazza, Nicholas J. Kirsch, Antonio Forenza Robert W. Heath and Kapil R. Dandekar, "Design and Evaluation of a Reconfigurable Antenna Array for MIMO Systems," *IEEE transactions on antennas and propagation*, Vol. 56, No. 3, pp. 869-881, 2008.
- [27] Mahmoud A. Abdalla, Ahmed M. Abdelreheem, Mohamed H. Abdegellel and Ali M. Ali, "Surface wave and mutual coupling reduction between two element array MIMO Antenna," **IEEE Conference Publications**, pp. 178-179, 2013.
- [28] A. A. Lotfi Neyestanak, Alex Danideh and Reza Sadeghifakhr, "Compact size microstrip array MIMO antenna operable in multiband", **IEEE Conference Publications**, pp. 158-161, 2008.
- [29] Sajad Mohammad Ali Nezhad and Hamid Reza Hassani, "A Novel Triband E-Shaped Antenna for MIMO Application," *IEEE antennas and wireless propagation letters*, Vol. 9, pp. 576-579, 2010.
- [30] S. Blanch, J. Romeu and I. Corbella, "Exact Representation of Antenna System Diversity Performance from Input Parameter Description," *IET Electronic Letters*, Vol. 39, No. 9, pp. 705-707, 2003.

- [31] M. Manteghi and Y. Rahmat-Samii, "Multiport Characteristics of a Wideband Cavity Backed Annular Patch Antenna for Multi polarization Operations", IEEE transactions on antennas and propagation, AP-Vol. 53, No. 1, January 2005, pp. 466-474.
- [32] D. M. Pozar, Microwave engineering, Second edition, New York, John Wiley, 1998.
- [33] R. Vaughan and J. B. Anderson, "Antenna propagation for mobile communication", London, IET, 2003.
- [34] V. H. Rumsey, Frequency Independent Antennas, (Academic Press, New York and London), 1966.
- [35] R. G. Hohlfeld and N. Cohen, "Self-Similarity and the Geometric Requirements for Frequency Independence in Antenna", vol. 7, pp. 79-84, 1999.

List of Publications

- [1]. Deepak Saluja, Rajesh Khanna, "A novel small size MIMO-PIFA antenna for LTE/4G/WiFi in mobile phones", Microwave and Optical Technology Letters (Communicated).