

BER and PAPR Analysis of OFDM System for $\pi/4$ -DQPSK and GMSK

*A Dissertation submitted in partial fulfillment of the
requirements for the award of the Degree of*

MASTER OF ENGINEERING

IN

ELECTRONICS AND COMMUNICATION ENGINEERING

Submitted By

Paramvir Bhatti

Roll No.: 801161032

Under the Guidance of

Dr. Kulbir Singh

Associate Professor



DEPARTMENT OF ELECTRONICS AND COMMUNICATION ENGINEERING

THAPAR UNIVERSITY

(Established under the section 3 of UGC Act, 1956)

PATIALA – 147004 (PUNJAB)

CERTIFICATE

I, Paramvir Bhatti, hereby certify that the work which is being presented in this dissertation entitled “**BER and PAPR Analysis of OFDM System for $\pi/4$ -DQPSK and GMSK**” by me in partial fulfilment of the requirements for the award of degree of Master of Engineering in Electronics and Communication Engineering from Thapar University, Patiala, is an authentic record of my own work carried out under the supervision of **Dr. Kulbir Singh** and refers other researcher’s works which are duly listed in the reference section.

The matter presented in this dissertation has not been submitted in any other University/Institute for the award of any other degree.

Date:

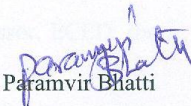
Paramvir Bhatti

Roll No. 801161032

It is certified that the above statement made by the student is correct to the best of our knowledge and belief.

Date: 15/7/2013

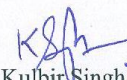
(Dr. Kulbir Singh)

Asso. Professor (ECED)

Thapar University, Patiala

Countersigned by:



HEAD ECED

Thapar University, Patiala

Dean of Academic Affairs

Thapar University, Patiala

ACKNOWLEDGEMENT

All praises to almighty WAHEGURU who give me strength and abilities to complete this dissertation work successfully.

I would like to give my sincere gratitude to honourable supervisor **Dr. Kulbir Singh**, Associate Professor ECED, for his assistance and good guidance time after time which made our dissertation work become more precise and attractive. He supervises me and gives his spare time to discuss more about the problem of dissertation work. At the same time, I am grateful to Head of Department, **Dr. Rajesh Khanna** for providing the facility for completion of dissertation.

I am also very thankful to **Mr. Ankush Kansal**, Assistant Professor, ECED, for his continuous guidance and support.

I am grateful to my beloved parents and friend for their love and continuous support during the dissertation work at Thapar University until finish.

Also, I would like to thank to all the members of the Electronics and Communication Department whose love and affection made my stay at Thapar University campus a memorable.

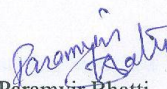
Paramvir Bhatti

Roll No. 801161032

Abstract

In the last few years wireless communications have seen a fast growth due to the high mobility that they allow. With promising technology and ever-increasing wireless devices, the spectrum is becoming scarcer day by day. In this case, using Orthogonal Frequency Division Multiplexing (OFDM) for spectrally efficient transmission is an alternative solution.

OFDM is a bandwidth efficient multicarrier modulation scheme where the available spectrum is divided into subcarriers, with each subcarrier data modulated at low rate. OFDM has gained a tremendous interest in recent years because of its spectral efficiency and robustness in the presence of severe multipath channel conditions with simple equalization, robustness against Inter-Symbol Interference (ISI), multipath fading, in addition to its high spectral efficiency. However, the Peak to Average Power Ratio (PAPR) is a major drawback of multicarrier transmission system such as OFDM. As power amplifier is used at the transmitter side, OFDM signal forced the amplifier to work in the nonlinear region due to the high PAPR which leads to in-band distortion and out-band radiation. This can be avoided by increasing the dynamic range of power amplifier which leads to high cost and high consumption of power at the base station. To reduce PAPR number of techniques has been proposed in literature.

In this dissertation, MPSK, $\pi/4$ –DQPSK, GMSK modulation schemes are implemented in OFDM system. GMSK is Continuous Phase Modulation (CPM), which can give higher bandwidth efficiency than QPSK and higher-order MPSK. And $\pi/4$ –DQPSK gives much smaller fluctuations of the envelope than that of QPSK. Bit Error Rate or Bit Error Ratio (BER) performance analysis is done for MPSK, $\pi/4$ –DQPSK, GMSK modulation schemes with OFDM system under AWGN channel, Rayleigh fading channel, Rician fading channel. In case of GMSK-OFDM, BER decreases more rapidly with respect to SNR when compared with 64PSK.

This dissertation presents analysis of PAPR for above described OFDM system. An efficient PAPR reduction technique i.e the Selected Mapping (SLM) is implemented. The PAPR is analysed using Complementary Cumulative Distribution Function (CCDF), which is the one of the most regularly used parameter to measure the

efficiency of any PAPR technique. Reduction in PAPR is obtained for OFDM system with above mentioned modulation techniques.

TABLE OF CONTENTS

CERTIFICATE	i
ACKNOWLEDGEMENT	ii
ABSTRACT	iii
TABLE OF CONTENTS	v
LIST OF FIGURES	vii
LIST OF TABLES	ix
LIST OF ABBREVIATION	x
CHAPTER 1: INTRODUCTION	1
1.1 Preamble	1
1.2 History Of Mobile Wireless Communications	2
1.3 OFDM	4
1.4 Digital Modulation Schemes	6
1.5 Selective Mapping	6
1.6 Organisation of Dissertation	6
CHAPTER 2: LITERATURE REVIEW	8
2.1 Signal Scrambling Techniques	8
2.2 Signal Distortion Techniques	14
2.3 Motivation	16
2.4 Objective	17
CHAPTER 3: OFDM	18
3.1 Overview of OFDM	19
3.1.1 Mathematical Representation of OFDM	20
3.1.2 IFFT and FFT Implementation	22
3.1.3 OFDM with a cyclic prefix	24
3.2 Applications	25
3.2.1 IEEE 802.11	25
3.2.2 Digital Audio Broadcasting	26
3.2.3 Digital Video Broadcasting	27
3.2.4 Asynchronous Digital Subscriber Lines	27
3.3 Advantages of OFDM Transmission	27

3.4 Drawbacks of OFDM Transmission	28
3.4.1 Orthogonality	28
3.4.2 Synchronization	29
3.5.3 PAPR in OFDM	29
CHAPTER 4: PAPR AND SLM	31
4.1 Introduction	31
4.2 PAPR	32
6.2.1 Distribution of the PAPR	33
4.3 Selected Mapping Technique	34
CHAPTER 5: DIGITAL MODULATION	37
5.1 Introduction	37
5.2 Phase Shift Keying	38
5.3 MPSK	38
5.4 $\pi/4$ –DQPSK	41
5.5 Gaussian Minimum Shift Keying	42
CHAPTER 6: CHANNEL FADING AND MODELS	45
6.1 Fading	45
6.2 Multipath Fading	45
6.2.1 Types of Multipath Fading	46
6.2.1.1 Large Scale Fading	47
6.2.1.1 Small Scale Fading	47
6.3 Channel Models	54
6.3.1 Additive White Gaussian Noise (AWGN)	55
6.3.1.1 Gaussian Distribution	57
6.3.2 Rayleigh Fading Channel	58
6.3.2.1 Rayleigh Distribution	58
6.3.3 Rician Fading Channel	59
6.3.3.1 Rician Distribution	59
CHAPTER 7: RESULTS AND DISCUSSION	61
CHAPTER 8: CONCLUSION AND FUTURE SCOPE	77
8.1 Conclusion	77
8.2 Future Scope	78
REFERENCES	
PUBLICATIONS	

LIST OF FIGURES

NO.	TITLE	PAGE NO.
3.1	OFDM time/frequency representation	19
3.2	Basic OFDM transceiver	22
3.3	Generate Cyclic Prefix	24
4.1	PAPR for a 16-channel OFDM signal	33
4.2	Block Diagram of SLM	35
5.1	MPSK constellations. (a) QPSK. (b) 8PSK	40
5.2	MPSK (a)modulator (b)Coherent MPSK demodulator	40
5.3	Constellations of $\pi/4$ –QPSK and $\pi/4$ –DQPSK	42
5.4	GMSK (a) transmitter (b) receiver	43
6.1	Multipath fading channel	46
6.2	Large scale& small scale fading	48
6.3	Types of small scale fading	49
6.4	Typical case of (a) Frequency Selective (b) Flat Fading	52
6.5	Type of fading experienced by a signal as a function of (a) symbol period (b) baseband signal width	54
6.6	Model for received signal passed through an AWGN channel	56
6.7	Gaussian distribution (a) PDF (b) CDF	57
6.8	Rayleigh random variable (a) PDF (b) CDF	58
6.9	Rician random variable (a) PDF and (b) CDF for $\sigma = 1$	60
6.1	Block Diagram of SLM	58
7.1	BER performance of 16PSK and 64PSK over AWGN channel	62
7.2	BER performance of GMSK-OFDM over AWGN channel	63
7.3	BER performance of $\pi/4$ –DQPSK over AWGN channel	63
7.4	BER performance for different modulation schemes over AWGN channel	64
7.5	BER performance for different modulation schemes over Rayleigh fading channel	65
7.6	BER performance for different modulation schemes over Rician fading channel	65
7.7	PAPR for 16PSK (a) CCDF Function (b) Histogram	66
7.8	PAPR for 64PSK (a) CCDF Function (b) Histogram	67

7.9	PAPR for $\pi/4$ –DQPSK (a) CCDF Function (b) Histogram	67
7.10	PAPR for GMSK (a) CCDF Function (b) Histogram	68
7.11	PAPR for 16PSK after applying SLM with U=10 (a) CCDF (b) Histogram	69
7.12	PAPR for 16PSK after applying SLM with U=20 (a) CCDF (b) Histogram	69
7.13	PAPR for 16PSK after applying SLM with U=30 (a) CCDF (b) Histogram	70
7.14	PAPR for 64PSK after applying SLM with U=10 (a) CCDF (b) Histogram	71
7.15	PAPR for 64PSK after applying SLM with U=20 (a) CCDF (b) Histogram	71
7.16	PAPR for 64PSK after applying SLM with U=30 (a) CCDF (b) Histogram	72
7.17	PAPR for $\pi/4$ –DQPSK after applying SLM with U=10 (a) CCDF (b) Histogram	73
7.18	PAPR for $\pi/4$ –DQPSK after applying SLM with U=20 (a) CCDF (b) Histogram	73
7.19	PAPR for $\pi/4$ –DQPSK after applying SLM with U=30 (a) CCDF (b) Histogram	74
7.20	PAPR for GMSK after applying SLM with U=10 (a)CCDF (b) Histogram	75
7.21	PAPR for GMSK after applying SLM with U=20 (a) CCDF (b) Histogram	75
7.22	PAPR for GMSK after applying SLM with U=30 (a) CCDF (b) Histogram	76

LIST OF TABLES

NO.	TITLE	PAGE NO.
7.1	Values of PAPR and elapsed time for Different Modulation Scheme	68
7.2	Summary of reduced PAPR and elapsed time for 16PSK	70
7.3	Summary of reduced PAPR and elapsed time for 64PSK	72
7.4	Summary of reduced PAPR and elapsed time for $\pi/4$ –DQPSK	74
7.5	Summary of reduced PAPR and elapsed time for GMSK	76

List of Abbreviations

1G	First Generation
2G	Second Generation
3G	Third Generation
4G	Fourth Generation
$\pi/4$ –DQPSK	$\pi/4$ –Differential Quadrature Phase Shift Keying
AWGN	Additive White Gaussian Noise
ADSL	Asymmetric Digital Subscriber Line
ADC	Analog to Digital Converter
ASK	Amplitude Shift Keying
ACE	Active Constellation Extension
ACP	Aggressive Clipping Projection
BER	Bit Error Rate
BTS	Base Transceiver Station
CP	Cyclic Prefix
CDF	Cumulative Distribution Function
CCDF	Complementary Cumulative Distribution Function
CDMA	Code Division Multiple Access
CPM	Continuous Phase Modulation
DVB-T	Terrestrial Digital Video Broadcasting
DAB	Digital Audio Broadcasting
DAC	Digital to Analog Converter
DFT	Discrete Fourier Transform
DSI	Dummy Sequence Insertion
DSSS	Direct Sequence Spread Spectrum
DMT	Discrete Multi Tone
FFT	Fast Fourier Transform
FM	Frequency Modulation
FSK	Frequency Shift keying
FHSS	Frequency Hopping Spread Spectrum
FDMA	Frequency Division Multiple Access
EM	Electromagnetic
BRAN	Broadband Radio Access Networks

FDM	Frequency Division Multiplexing
FDMA	Frequency Division Multiple Access
GMSK	Gaussian Minimum Shift Keying
GSM	Global System for Mobile communications
GI	Guard Interval
HiperLAN	High Performance Radio LAN
ISI	Inter Symbol Interference
ICI	Inter Carrier Interference
IEEE	Institute of Electrical and Electronic Engineers
IFFT	Inverse Fast Fourier Transform
IDFT	Inverse Discrete Fourier Transform
IMTS	Improved Mobile Telephone System
IP-PTS	Interleaved Partitioning Partial Transmit Sequence
AP-PTS	Adjacent Partitioning PTS
LAN	Local Area Network
LOS	Line Of Sight
MIMO	Multiple Input Multiple Output
MPSM	Multi-Points Square Mapping
MSK	Minimum Shift Keying
NRZ	Non-Return to Zero
OFDM	Orthogonal Frequency Division Multiplexing
OFDMA	Orthogonal Frequency Division Multiple Access
PTS	Partial Transmit Sequences
PSK	Phase Shift Keying
PA	Power Amplifier
PAPR	Peak to Average Power Ratio
PRC	Peak Reduction Carriers
QPSK	Quadrature Phase Shift Keying
QAM	Quadrature Amplitude Modulation
RF	Radio Frequency
SNR	Signal to Noise Ratio
SLM	Selective Level Mapping
SC	Sub-Carrier

SFN	Single Frequency Network
TR	Tone Reservation
TI	Tone Injection
TDMA	Time Division Multiple Access
WiMAX	Worldwide Interoperability for Microwave Access
Wi-Fi	Wireless Fidelity
WLAN	Wireless Local Area Network

CHAPTER 1

INTRODUCTION

1.1 Preamble

The demand for high data rate services has been increasing day by day and there is no slowdown in sight. Almost every existing physical medium capable of supporting broadband data transmission to our homes, offices and schools has been or will be used in the future. This includes both wired (Digital Subscriber Lines, Cable Modems, Power Lines) and wireless media. Generally, these services require very reliable data transmission over very harsh environments. Most of the transmission systems experience many factors which leads to degradation of the system, such as noise, attenuation, multipath, fading, time variation, interference, non-linearity's. The reliable data transmission system must meet constraints, such as finite transmit power and most importantly finite cost. One physical-layer technique that has recently gained much popularity due to its robustness in dealing with these impairments is multi-carrier modulation [1]. Information transmission with high spectral efficiency and variable bit rate are major requirements for the modern communication system to deal with the high quality services to be delivered to the customers. Because in the wireless environment signals are usually impaired by fading and multipath delay spread phenomenon, hence, conventional single carrier mobile communication systems do not perform well.

In such channels, extreme fading of the signal amplitude occurs and ISI due to the frequency selectivity of the channel appears at the receiver side. This leads to a high probability of errors and the system's overall performance decreases [1]. Various techniques like channel coding and adaptive equalization have been widely used as a solution to these problems. However, due to the inherent delay in the coding and equalization process and high cost of the hardware, it is quite difficult to use these techniques in systems operating at high bit rates. Moreover, an alternative solution is to multicarrier communication system is OFDM. OFDM is used in several applications such as Asymmetric Digital Subscriber Lines (ADSL), a system that makes high bit-rates possible over twisted-pair copper wires [2]. It has been standardized and recommended for Digital Audio Broadcasting (DAB) in Europe and it is already used for Terrestrial

Digital Video Broadcasting (DVB-T). The IEEE 802.11a/g standards for Wireless Local Area Network (WLAN) are also based on OFDM.

The purpose of this dissertation is to investigate how OFDM performs in different channel models such as Additive White Gaussian Noise (AWGN) channel, Rayleigh fading channel, Rician fading channel. In AWGN channel only one path between the transmitter and the receiver exists and only a constant attenuation and noise is considered, but in other channel models multipath effect is taken into account. PAPR for OFDM is also analysed in this dissertation. This is a basic investigation and it is intended as a basis of understanding OFDM better in order for future studies of this technique in multipath channels.

1.2 History of Mobile Wireless Communications:

The history of mobile communication [1, 2] can be categorized into three periods:

- The pioneer era
- The pre-cellular era
- The cellular era

In the pioneer era, a great deal of the fundamental research and development in the field of wireless communications took place. During 1860s James Clark Maxwell postulates electromagnetic (EM) waves in England, in 1880s Heinrich Rudolf Hertz demonstrated the existence of these waves and the invention of wireless telegraphy by Guglielmo Marconi during the 1890s in Italy was representative examples from Europe. Moreover, in Japan, the Radio Telegraph Research Division was established as a part of the Electro technical Laboratory at the Ministry of Communications and started to research wireless telegraph in 1896.

The application of wireless telegraphy to mobile communication systems started from the 1920s. This period, which is called the pre-cellular era, began with the first land-based mobile wireless telephone system installed by the Detroit Police Department in 1921 to dispatch patrol cars, followed by the New York City Police Department in 1932 [2]. These systems were operated in the frequency band of 2MHz. In 1946, the first commercial mobile telephone system, operated in the frequency band of 150MHz, was set up by Bell Telephone Laboratories in St. Louis. The demonstration system was a simple

analog communication system with a manually operated telephone exchange. Subsequently, in 1969, a mobile duplex communication system was realized in the frequency band of 450MHz. The telephone exchange of this modified system was operated automatically. The new system, called the Improved Mobile Telephone System (IMTS), was widely installed in the United States. However, because of its large coverage area, the system could not manage a large number of users or allocate the available frequency bands efficiently.

To overcome this problem, the cellular zone concept was developed by using the propagation characteristics of radio waves. The cellular zone concept divided a large coverage area into many smaller zones [1]. A frequency channel in one cellular zone is used in another cellular zone. However, the distance between the cellular zones that use the same frequency channels is sufficiently large to ensure that the probability of interference is quite low. The use of the cellular zone concept launched the third era, known as the cellular era. So far, the evolution of the analog cellular mobile communication system is described. There were many problems and constraints, such as, the incompatibility of the various systems in each country or region, which precluded roaming. In addition, analog mobile communication systems were unable to ensure sufficient capacity for the increasing number of users, and the speech quality was also not good.

To tackle these problems, the R&D of cellular mobile communication systems based on digital radio transmission schemes was initiated. These new mobile communication systems became known as the second generation (2G) of mobile communication systems, and the analog cellular era is regarded as the first generation (1G) of mobile communication systems [3]. 1G analog cellular system was actually a hybrid of analog voice channels and digital control channels. Frequency Modulation (FM) was used by analog voice channels and Frequency Shift keying (FSK) modulation was used by digital control channels [4].

2G digital systems use digital radio channels for both voice (digital voice) and digital control channels. 2G digital systems typically use more efficient modulation schemes, including Global System for Mobile communications (GSM), which uses Gaussian Minimum Shift Keying (GMSK). Digital radio channels offer a universal data transmission system, which can be divided into many logical channels that can perform

different services. To increase the spectral efficiency, 2G systems use multiple access (or multiplexing) technologies to allow more customers to share individual radio channels or use narrow channels to allow more radio channels into a limited amount of radio spectrum band. The three basic types of access technologies used in 2G systems are [4]: Frequency Division Multiple Access (FDMA), Time Division Multiple Access (TDMA), and Code Division Multiple Access (CDMA). FDMA reduces the Radio Frequency (RF) channel bandwidth; TDMA share a radio channel by assigning users to brief timeslot; CDMA divides a wide RF channel into many different coded channels (CDMA). Improvements in modulation techniques and multiple access technologies amongst other technologies inadvertently led to 2.5G and 3G.

1.3 OFDM

OFDM has become a popular technique for transmission of signals over wireless channels [5]. OFDM has been used in number of applications and adopted in several wireless standards such as DAB, DVB-T, the IEEE 802.11a [6] and the IEEE 802.16a [7]. OFDM is also being pursued for dedicated short-range communications (DSRC) for road side to vehicle communications and as a potential candidate for fourth generation (4G) mobile wireless system.

OFDM converts a frequency-selective channel into a number of parallel frequency flat subchannels. The Subcarrier spacing is carefully selected so that each SC is orthogonal their corresponding time domain waveforms, yet the signal spectra corresponding to the different subcarriers overlap in frequency. Hence, the available bandwidth is used very efficiently. If knowledge of the channel is available at the transmitter, then the OFDM transmitter can adapt its signaling strategy to match the channel. As OFDM uses a large collection of narrowly spaced subchannels, these adaptive strategies can approach the ideal water pouring capacity of a frequency-selective channel. In practice this is achieved by using adaptive bit loading techniques, where different sized signal constellations are transmitted on the subcarriers.

OFDM is a block modulation scheme where a block of N information symbols is transmitted in parallel on N low rate modulated SCs. The time duration of an OFDM symbol is N times larger than that of a single-carrier system, making the symbols much longer than the channel impulse response [4]. In this way, effect of ISI is minimised. An

OFDM modulator can be implemented as an IDFT on a block of N information symbols followed by an ADC. Moreover, to further mitigate the effects of ISI caused by channel time spread, each block of IDFT coefficients is typically preceded by a Cyclic Prefix (CP) or a Guard Interval (GI) consisting of G samples, such that the length of the CP is at least equal to the channel length. Under this condition, a linear convolution of the transmitted sequence and the channel is converted to a circular convolution [4]. As a result, the effects of the ISI are easily and completely eliminated. Moreover, this approach enables the receiver to use fast signal processing transforms such as Fast Fourier Transform (FFT) for OFDM implementation [5]. Similar techniques can be employed in single carrier systems as well, by preceding each transmitted data block of length N by a CP of length, while using frequency-domain equalization at the receiver.

OFDM has many advantages compared with other transmission techniques. One of such advantages is high spectral efficiency. The orthogonality in OFDM implies a precise mathematical relationship between the frequencies of the subchannels that use in the OFDM system. Each one of the frequencies is an integer multiple of a fundamental frequency. This ensures that a subchannel does not interfere with other subchannels even though the subchannels are overlapped. This results in high spectral efficiency.

Although OFDM has many advantages it also encountered some problems such as Inter-Carrier Interference (ICI), PAPR. The ICI occurs due to frequency error. In OFDM two types of frequency errors are present. These are frequency offset and error in the receiver master clock frequency. A high PAPR brings disadvantages like an increased complexity of the A/D and D/A converters and reduced efficiency of RF power amplifier [8]. OFDM signal consists of a number of independent modulated subcarriers that leads to the problem of PAPR. If all subcarriers are added coherently, the peak power is N times the average power of the signal where N is the total number of symbols in an OFDM signal. Thus, it is not possible to send this high peak amplitude signals to the transmitter without reducing peaks. Because power amplifier used for the transmission has a limited linear range and non-linear nature of power amplifier causes inter-modulation and out-of-band radiation. The high peak of OFDM signal can be reduced in several ways [8].

The focus of this dissertation is on study of OFDM with MPSK, $\pi/4$ – DQPSK and GMSK modulation techniques and analysis of PAPR for them and its reduction using SLM scheme

1.4 Digital Modulation Schemes

Modulation is the process of mapping information from a message source to high frequency carrier signal to make it suitable for transmission. In general it involves translating a baseband signal (source signal) to a modulated signal signal at a higher frequency (the carrier frequency, f_c). In a digital communication system, the source signal to be transmitted is discrete both in time and amplitude [1]. In digital modulation, an analog carrier signal is modulated by a discrete signal. Moreover, digital modulation methods can be considered as digital-to-analog conversion, and the corresponding demodulation or detection as analog-to-digital conversion. There are number of advantages of digital modulation over analog modulation, such as, noise immunity, robustness to channel impairments, security. Digital modulation is categories depending on process is used or factor of carrier frequency signal altered, like amplitude, frequency, phase or a combination of them is varied in accordance with the information to be transmitted. The most common digital modulation schemes include Phase Shift Keying (PSK), Frequency Shift Keying (FSK), Amplitude Shift Keying (ASK), GMSK. In this dissertation, MPSK, $\pi/4$ –DQPSK and GMSK are implemented.

1.5 Selective Mapping

Selective Mapping (SLM) approach has been proposed by Bauml in 1965 [9]. This method is used for minimization of PAPR of multicarrier transmission system with selected mapping. A complete set of candidate signal is generated signifying the same information in selected mapping, and then concerning the most favorable signal is selected as consider to PAPR and transmitted. In the SLM, the input data is multiplied by random series and resultant series with the lowest PAPR is chosen for transmission. One of the preliminary probabilistic methods is SLM method for reducing the PAPR problem. The good side of selected mapping method is that it doesn't eliminate the peaks, and can handle any number of subcarriers.

1.6 Organisation of Dissertation

Chapter 1 gives introduction to the dissertation, brief introduction to OFDM system, digital modulation schemes and SLM.

Chapter 2 gives literature survey about the topic of the dissertation. In order to start the dissertation, the first step is to study the papers that have been already published by other researchers. Paper related to this work are chosen and studied. With the help of literature review, it becomes easier to perform this work.

Chapter 3 presents an introduction of OFDM and describe its principles, the basic OFDM transceiver model, its applications, advantages and disadvantages.

Chapter 4 explains the digital modulation schemes. This chapter introduces modulation schemes, such as, PSK, MPSK, $\pi/4$ –DQPSK, GMSK their transceivers and constellation diagrams.

Chapter 5 begins with the introduction of fading, followed by brief introduction to different types of fadings and fading effects. This chapter also introduces different types of channel models and their distributions.

Chapter 6 explains the PAPR in OFDM and the effects of PAPR on OFDM system. This chapter also includes list of different PAPR reduction schemes and briefly introduces SLM scheme.

Chapter 7 presents the simulation results of OFDM system. The OFDM system performance is analysed on the basis of BER for different modulation schemes this chapter also includes the simulation results for PAPR and its reduction with SLM.

Chapter 8 includes the conclusion and future scope of the work.

CHAPTER 2

LITERATURE SURVEY

There have been many new approaches developed during the last few years. Several PAPR reduction techniques have been proposed in the literature. These techniques are mainly divided into two categories

- Signal Scrambling Techniques [10-25]
- Signal Distortion Techniques [26-33]

Signal scrambling techniques work with side information which minimized the effective throughput since they commence redundancy. Signal distortion techniques introduce band interference and system complexity also. Signal distortion techniques minimize high peak dramatically by distorting signal before amplification.

2.1 Signal Scrambling Techniques

Coding techniques can be applied for signal scrambling, M sequences, Golay complementary sequences codes can be used to reduce the PAPR efficiently. Block coding technique has been proposed by T. A. Wilkison and A. E. Jones in 1995 for the minimization of the PAPR of multicarrier communication system [10]. The objective of this paper is that PAPR can be minimized by block coding the data. The block coding techniques has three stages for the development. The first stage works with the collection of appropriate sets of code words for any number of carriers, any M-ary phase modulation method, and any coding rate. The second stage deals with the collection of the sets of code words which enable proficient implementation of the encoding/decoding. The third stage offers error deduction and correction potential. The development of the technique in terms of the selection of suitable sets of code words based on Shapiro-Rudin sequences, Golay complementary sequences is done and reduction of 3dB is achieved in the value of PAPR

The Block coding scheme with Error Correction has been proposed by A. Hyo-Joo *et al.* [11] for minimization of PAPR of an OFDM system. The Block coding proposed by them has error correction capability. In block coding method, the OFDM symbol can be reduced by selecting only those code words with lower PAPR. In this paper, the key

object of the method is proposed that properly designed block codes can not only minimize the PAPR, but also give error correction capability. In this paper minimum PAPR is achieved for the OFDM system with QPSK and four carriers and BER significantly improves as compared with uncoded OFDM system.

A scheme is proposed to reduce the PAPR of OFDM system and also to detect transmission errors. The proposed scheme is as termed sub-block-coding and this was proposed by Y. Zhang *et al.*[12] Two extensions of the sub-block-coding are also proposed in the form of redundant bit location optimized sub-block-coding and combination-optimized sub-block-coding. Performance results obtained with sub-block-coding are given and compared with that of the cyclic coding scheme proposed by D. Wulich in 1996 [13] for the same purpose. The results show that, at the same code rate $3/4$, the proposed scheme can achieve the same performance as the cyclic code but with lower complexity. The results obtained with the two extended techniques are also given and compared with that of the sub-block-coding. It was found that at code rate $3/4$, these two new techniques can achieve a higher peak-to-average power ratio reduction than the standard sub-block-coding.

SLM approach has been proposed by Bauml in 1965 [9]. This method is used for minimization of PAPR of multicarrier transmission system with selected mapping. In this paper, parallel data signal of length N is multiplied by a predetermined set of U phase vectors of length N and generates U alternative signals. Out of U alternative signals, one of them with the least PAPR is selected for transmission. To allow the receiver to recover the original data to the multiplying sequence can be sent as 'side information'. The drawback of this method is that as number of phase increases complexity of the system increases.

S. Y. Le Goff [14] in 2009 proposed SLM scheme for reducing PAPR without transmitting side information. In his paper, he shows that this technique based on QPSK and 16-QAM modulations is particularly attractive for systems using a large number of subcarriers. The probability of side information detection error can be made very small by increasing the extension factor and/or the number of subcarriers. In the cases where this probability becomes very low, the BER performance difference between the proposed technique and classical SLM using error-free side information has been shown to be negligible. For OFDM systems with a large number of subcarriers, the only significant

price to pay for implementing the proposed technique instead of classical SLM is a slight complexity increase at the receiver side due to the use of a side information detection block.

K. D. Choe *et al.* [15] proposed prescrambling method consists of the following processes. First, the optimum data reversal positions which can reduce PAPR value are searched. With these results, PAPR value of input data is predicted by the use of correlator. And then, before IFFT processing, source information is rearranged by inverting data bits in order to reduce the PAPR value. The simulation results show that this method has less computational complexity and reasonable PAPR reduction capability than PTS method. Consequently the number of IFFT used in this system is less than that used in RTS method systems. And feed-back time delay does not exist. Therefore, performance of computational time and complexity surpasses other methods.

Another signal scrambling technique has been proposed by S. H. Muller and J. B. Huber in 1997 [16]. In this paper Muller proposed Partial Transmit Sequence (PTS) technique which is based on the phase shifting of sub-blocks of data and multiplication of data structure by random vectors. This method is flexible and effective for OFDM system. The main purpose behind this method is that the input data frame is divided into non-overlapping sub blocks and each sub block is phase shifted by a constant factor to reduce PAPR. PTS is probabilistic method for reducing the PAPR problem in multicarrier systems. It can be said that PTS method is a modified method of SLM. PTS method works better than SLM method. The major advantage of this scheme is that there is no need to send any side information to the receiver of the system, when differential modulation is applied in all sub blocks.

In 2010 C. L. Wang *et al.* [17] propose PAPR reduction methods for OFDM systems commonly use four times oversampling for the discrete-time OFDM signal to approximate the peak of the continuous-time OFDM signal. However, the four times oversampling process increases the computational complexity. In this paper, they propose a new low-complexity method to efficiently estimate the PAPR value of the OFDM signal. The proposed scheme uses an interpolator to find the peak of the four times oversampled OFDM signal around some searched samples of the original discrete-time OFDM signal using oversampling with a factor lower than four. Some criteria are derived to determine the interpolation filter length and the threshold of sample power for the

search process. As compared to the method with four times oversampling, the proposed PAPR estimation scheme achieves close performance with only about half of the computational complexity. It is also shown that the proposed approach can easily be combined with the selected mapping method for PAPR reduction, where the complexity is significantly reduced but the performance is degraded only slightly.

In [18], Y. Zhou, T. Jiang proposed Multi-Points Square Mapping (MPSM) - PTS scheme which extends the QPSK constellation points to disjoint points of 16-QAM constellation and eliminates the requirement of side information. He proposed M-PTS scheme could offer good PAPR reduction, which is almost the same as that of conventional PTS scheme. However, the proposed M-PTS scheme needs not to transmit side information. Therefore, the proposed M-PTS scheme has better bandwidth efficiency and BER performance compared with the conventional PTS scheme.

The Interleaved Partitioning Partial Transmit Sequence (IP-PTS) scheme is an attractive technique for PAPR reduction in OFDM systems, which was proposed by X. Wu *et al.* in 2010 [19]. But the PAPR performance of IP-PTS is inferior to that of the Adjacent Partitioning PTS (AP-PTS) scheme because the candidates generated in IP-PTS are not fully independent. This paper analyzes the independence of candidates in IP-PTS in detail and finds the effective phase factor vectors. In order to improve the PAPR performance of IP-PTS, a conjugate IP-PTS (C-IP-PTS) scheme is proposed. By performing the conjugate operations on some sub-blocks, the number of candidates is increased. Because of the conjugate property of the discrete Fourier transform (DFT), the additional inverse DFT can be avoided. By optimizing the conjugate sequence, the complexity can be further lowered. Simulation results show that C-IP-PTS can obtain better PAPR performance compared with AP-PTS; moreover, the computational complexity of C-IP-PTS is not high.

B. M. Kang *et al.* in 2007 [20] proposes an ACE (active constellation extension) method to reduce PAPR without any data rate loss. In this method, the target PAPR is firstly set and then the clipping is used. Next, the active extending is made for the mapping the dispersive constellation onto the fixed point of extended constellation. The main advantage of this method is that it can meet target PAPR without any data rate loss. Unlike the conventional phase rotation method, the side information is not required in this method. So, the target PAPR by the extension of the constellation level is achieved. Using

this method upto 4dB reduction in PAPR by the 16-QAM extension, and can expect the target PAPR by the 64-QAM ACE. This ACE PAPR reduction method has more reduction capability, compared with the conventional SLM or PTS method. Also, it has lower BER (bit error rate) than ordinary same constellation level symbols.

Interleaving technique has been proposed by A. D. C. Jayalath, C. Tellambura [21], for reduction PAPR of an OFDM system. In this paper data randomization technique has proposed for the minimization of the PAPR. The notion that highly correlated data structures have large PAPR can be reduced, if long correlation pattern is broken down. Also, to minimize the system complexity method has been proposed in this paper. The basic idea in adaptive interleaving is to set up an initial terminating threshold. PAPR value goes below the threshold rather than seeking each interleaved sequences. The minimal threshold will compel the adaptive interleaving to look for all the interleaved sequences. The advantage this scheme is that it is less complex than the PTS technique but obtains comparable result.

G. Yang and Z. Yang proposed Tone Reservation (TR) method for PAPR reduction in 2007 [22]. The tone reservation (TR) algorithm is an efficient technique to reduce the PAPR of a multicarrier signal. In this paper he proposes a method in which a small number of subcarriers (tones) are reserved to create a cancellation signal which can cancel the high peaks in the information-carrying signals at the transmitter. The cancellation signal can be easily stripped off at the receiver. This approach can reduce the PAPR of the OFDM signals without introducing any additional distortions to the information data and does not require side information. However, TR can have a high computational cost due to the difficulties of finding an effective cancellation signal in the time domain from only a small number of reserved tones in the frequency domain. In this paper, he proposes a novel TR scheme to generate the cancellation signal by using a few steps of FFT/IFFT iteration, which greatly reduces the number of iteration.

Tone Reservation (TR) method is used for PAPR reduction [23]. The main idea of this method is to keep a small set of tones for PAPR reduction. This can be originated as a convex problem and this problem can be solved accurately. The amount of PAPR reduction depends on some factors such as number of reserved tones, location of the reserved tones, amount of complexity and allowed power on reserved tones. This method explains an additive scheme for minimizing PAPR in the multicarrier communication

system. It shows that reserving a small fraction of tones leads to large minimization in PAPR even using with simple algorithm at the transmitter of the system without any additional complexity at the receiver end. The advantage of TR method is that it is less complex, no side information and also no additional operation is required at the receiver of the system. Tone reservation method is based on adding a data block and time domain signal. A data block is dependent time domain signal to the original multicarrier signal to minimize the high peak. This time domain signal can be calculated simply at the transmitter of system and stripped off at the receiver.

In this paper, H. G. Ryu *et al.* propose a Dummy Sequence Insertion (DSI) method for PAPR reduction [24]. The complementary sequence and the combination of the correlation sequence belong to the dummy sequence. Flipping technique can be combined into DSI method to effectively lower the PAPR reduction. Also, PAPR threshold technique escalates the processing speed. Unlike the conventional PTS and SLM methods, the specified dummy sequence is inserted only for PAPR reduction and any kind of side information is not necessary. So, BER of the DSI method is independent of the error in the dummy data sequence. Although the DSI method is not better than the conventional PTS and block coding methods with respect to the PAPR reduction performance, the DSI method improves the BER performance than the conventional PTS and is even more spectrally efficient than the conventional block coding for PAPR reduction.

Tone injection (TI) is a promising PAPR reduction technique proposed by Cagdas Tuna and D. L. Jones, C. Tuna [25]. In their paper, they propose that cyclically extends QAM constellations to allow an alternative encoding with lower PAPR at the transmitter. They present a new efficient complex-baseband algorithm which performs TI by using aggressive clipping to combat large peaks. An approximated analog PAPR reduction of up to 5.1 dB at a 10^{-5} symbol-clip probability is obtained for 64-channel 16-QAM OFDM. This is a very fast and practical peak-power reduction method for OFDM systems that essentially achieves the same PAPR as single-carrier modulation for large constellations. The results show great promise for PAPR reduction for an approximated analog signal. Thus, the TI with Aggressive Clipping Projection (TI-ACP) method can offer considerable hardware and power savings, particularly for systems with a small number of broadcast transmitters. TI-ACP is very well suited for all constellation sizes, thereby making TI-ACP a superb PAPR-reduction solution for commercial applications.

2.2 Signal Distortion Techniques

The clipping [26] is one of the simplest distortion based technique to reduce the PAPR of OFDM signal. It reduces the peak of the OFDM signal by clipping the signal to the desired level. Clipping yields distortion power, which called clipping noise, and expands the transmitted signal spectrum, which causes interfering Clipping is nonlinear process and causes inband noise distortion, which causes degradation in the performance of BER and out-of-band noise, which decreases the spectral efficiency[27]. Clipping and filtering technique is effective in removing components of the expanded spectrum. Although filtering can decrease the spectrum growth, filtering after clipping can reduce the out-of-band radiation, but may also cause some peak re-growth, which the peak signal exceeds in the clip level.

H. G. Ryu *et al.* in 2002 [28] propose a new PAPR reduction method using soft clipping and filtering. Unlike conventional hard clipping, soft clipping has non-zero slope in the clip region. Next, filtering, which uses additional FFT and IFFT processes, is applied in order to reject the out-of-band clip noise. Although the filtering removes the out-of-band noise, it oppositely increases PAPR by a small amount. Since an HPA increases the power consumption according to the linearity range, soft clipping for an SSPA lowers power consumption and is more efficient than the conventional hard clipping method. By the results of the proposed method, the wanted PAPR can be obtained and there is no out-of-band radiation caused by the clipping process

The peak windowing method has been suggested by R. V. Nee, A. Wild [29]. By using this method it is possible to remove large peaks at the cost of a slight amount of self interference when large peaks arise infrequently. Peak windowing reduces PAPR at the cost of increasing the BER and out-of-band radiation. Clipping is a one kind of simple introduces PAPR reduction technique which is self interference. The technique of peak windowing offers better PAPR reduction with better spectral properties. Peak Windowing technique provides better PAPR reduction with better spectral properties than clipping. In peak windowing method we multiply large signal peak with a specific window, for example; Gaussian shaped window, cosine, Kaiser and Hamming window. Windowing method, PAPR can be obtained to 4dB which from the number of independent subcarriers. The loss in Signal-To-Noise Ratio (SNR) due to the signal distortion is limited to about 0.3dB.

The Envelope Scaling technique has been proposed by P. Foomooljareon, W. A. C. Fernando in [30]. They proposed a new algorithm to reduce PAPR by scaling the input envelope for some subcarriers before they are sent to IFFT. In this paper, they used 256 subcarriers with QPSK modulation technique, so that envelopes of all the subcarriers are equal. The idea behind this scheme is that the input envelope in some sub carrier is scaled to achieve the smallest amount of PAPR at the output of the IFFT. Thus, the receiver of the system doesn't need any side information for decoding the receiver sequence. This scheme is appropriate for QPSK modulation; the envelopes of all subcarriers are equal. Results show that PAPR can be reduced significantly at around 4 dB. Finally the system of single scaling factor and number of clusters equal to number of sub carriers is recommended.

Peak Reduction Carrier has been proposed by C. E. Tan and I. J. Wassell to use of the data bearing Peak Reduction Carriers (PRCs) to reduce the effective PAPR in the OFDM system [31]. This scheme includes the use of a higher order modulation scheme to represent a lower order modulation symbol. This permits the amplitude and phase of the PRC to be positioned within the constellation region symbolizing the data symbol to be transmitted. This scheme is appropriate for PSK modulation; where the envelopes of all subcarriers are equal. When the QAM modulation scheme will be implemented in the OFDM system, the carrier envelope scaling will result in the serious BER degradation. To limit the BER degradation, amount of the side information would also be excessive when the number of subcarriers is large.

A uniformly distributed nonlinear companding scheme efficiently reduces PAPR with a low BER. However, the uniformly distributed companding scheme cannot perform variably to satisfy the different performance requirements for the systems. Therefore, S. S. Jeng, J. M. Chen in 2011 [32] proposes a novel scheme that transforms the OFDM signals into a trapezium distribution. The uniformly distributed companding scheme is a special case of the proposed scheme. The general formulas of the proposed scheme are derived and the trade-off between PAPR reduction and BER performance is achieved by setting the value of a parameter. Then, the simulation results show the PAPR reduction and the BER over the AWGN and multipath channels, indicating that the proposed scheme provides a favourable trade-off between the PAPR reduction and the BER.

Companding is another popular distortion based scheme for PAPR reduction in OFDM system. In [33], Wang et al. proposed a scheme based on μ -law companding to reduce the PAPR of OFDM signal. In μ -law companding scheme the peak value of the OFDM signal before and after companding remains same, which keeps peak power of the OFDM signal unchanged but the average power of the OFDM signal after companding increases and therefore the PAPR of the OFDM signal gets decreased. But due to increase in the average power of the OFDM signal the error performance of μ -law companding scheme degrades.

2.3 Motivation

Multimedia is effectively an infrastructure technology with widely different origins in computing, telecommunications, entertainment and publishing. New applications are emerging especially wireless technology. The radio environment is harsh, due to the many reflected waves and other effects. Using adaptive equalization techniques at the receiver could be the solution, but there are practical difficulties in operating this equalization in real-time at several Mb/s with compact, low-cost hardware.

A promising candidate that eliminates a need for the complex equalizers is the OFDM, a multiple carrier modulation technique. OFDM is robust in adverse channel conditions and allows a high level of spectral efficiency. It effectively mitigates performance degradations due to multipath and is capable of combating deep fades in part of the spectrum. The OFDM waveform can be easily modified to adjust to the delay spread of the channel. OFDM can handle large delay spreads easier to the independence of the carriers and the flexibility of varying the cyclic prefix length. OFDM allows efficient operation in both FDD and TDD mode as very short or no pre-ambls are needed. Multiple access techniques which are quite developed for the single carrier modulations (e.g. TDMA, FDMA) had made possible of sharing one communication medium by multiple number of users. Multiple techniques schemes are used to allow many mobile users to share simultaneously a finite amount of radio spectrum. The sharing is required to achieve high capacity by simultaneously allocating the available bandwidth

While working with the wireless systems using these techniques various problems encountered are which degrade the system performance. Disadvantage of FDMA technique is its Bad Spectrum Usage. Disadvantages of TDMA technique is Multipath

Delay spread problem. In a typical terrestrial broadcasting, the transmitted signal arrives at the receiver using various paths of different lengths. Since multiple versions of the signal interfere with each other, it becomes difficult to extract the original information. The use of OFDM technique provides better solution for the above mentioned problems.

The performance of OFDM system depends on the type of modulation scheme used for carriers. Numbers of digital modulation scheme were implemented in OFDM system. Previously, GMSK and $\pi/4$ –DQPSK modulation schemes for OFDM system almost remain untouched. Hence, the potential of these modulations can be used in OFDM.

Many researchers have considered the PAPR problem in OFDM and numerous PAPR reduction approaches have been proposed. An efficient PAPR reduction technique i.e SLM approach has been proposed by Bauml in 1965 [9]. This method is used for minimization of PAPR of multicarrier transmission system with selected mapping.

2.4 Objective

The objectives of dissertation are

- To analyse the BER performance of OFDM system with MPSK, $\pi/4$ –DQPSK and GMSK modulation schemes under different channel conditions, i.e., AWGN channel, Rayleigh fading channel and Rician fading channel.
- To analyse the PAPR of OFDM system with MPSK, $\pi/4$ –DQPSK and GMSK modulation schemes.
- To analyse the improvement in PAPR with SLM for MPSK, $\pi/4$ –DQPSK and GMSK modulation schemes with different phase sequences.

3.1 Overview of OFDM

OFDM is a special form of multicarrier transmission scheme with a long history back to 1960 that has recently seen rising popularity in wireless and wire line applications. The recent interest in this technique is mainly due to the recent advances in digital signal processing technology. International standards making use of OFDM for high-speed wireless communications are already established or being established by IEEE 802.11, IEEE 802.16, IEEE 802.20 and ETSI BRAN committees. For wireless applications, an OFDM-based system can be of interest because it provides greater immunity to multipath fading and impulse noise, and eliminates the need for equalizers, while efficient hardware implementation can be realized using FFT techniques [34].

OFDM is a technique for transmitting data in parallel by using a large number of low rate modulated sub-carriers [2]. OFDM divides a given spectral allotment into many narrow subcarriers each with inherently small carrier spacing. These SCs are orthogonal to each other. The orthogonality of the carriers means that each carrier has an integer number of cycles over a symbol period. The spectrum of each carrier has a null at the centre frequency of each of the other carriers in the system. This result into elimination of cross-talk between SCs and inter-carrier guard bands are not required. The separation between carriers is theoretically minimal so there would be a very compact spectral utilization [35]. OFDM systems are very attractive for the way they handle ISI, which is usually introduced by frequency selective multipath fading in a wireless environment. Each sub-carrier is modulated at a very low symbol rate, making the symbols much longer than the channel impulse response. In this way, ISI is diminished. Moreover, if a guard interval is inserted between consecutive OFDM symbols, the effects of ISI can completely be vanished. This guard interval must be longer than the multipath delay. Although each SC operates at a low data rate, a total high data rate can be achieved by using a large number of SCs. ISI has very small or no effect on the OFDM systems hence an equalizer is not needed at the receiver side.

In the OFDM system, Inverse Fast Fourier Transform/Fast Fourier Transform (IFFT /FFT) algorithms are used in the modulation and demodulation of the signal respectively.

The length of the IFFT/FFT vector determines the tolerance of the system to errors caused by the multipath channel. The time duration of this vector is chosen so that it is much larger than the maximum delay time of echoes in the received multipath signal [36].

OFDM is generated by firstly choosing the spectrum required, based on the input data, and modulation scheme used. Each carrier to be produced is assigned some data to transmit. The required amplitude and phase of the carrier is then varied based on the modulation scheme (typically differential BPSK, QPSK, or QAM). Then, the IFFT converts this spectrum into a time domain signal.

The FFT transforms a cyclic time domain signal into its equivalent frequency spectrum. Finding the equivalent waveform, generated by a sum of orthogonal sinusoidal components, does this. The amplitude and phase of the sinusoidal components represent the frequency spectrum of the time domain signal [36]. A more complete description of an OFDM signal can be seen in fig. 3.1 which shows, an OFDM signal is divided in both time and frequency domain and so increases the capacity of the system in addition to the less interference of the adjacent symbols.

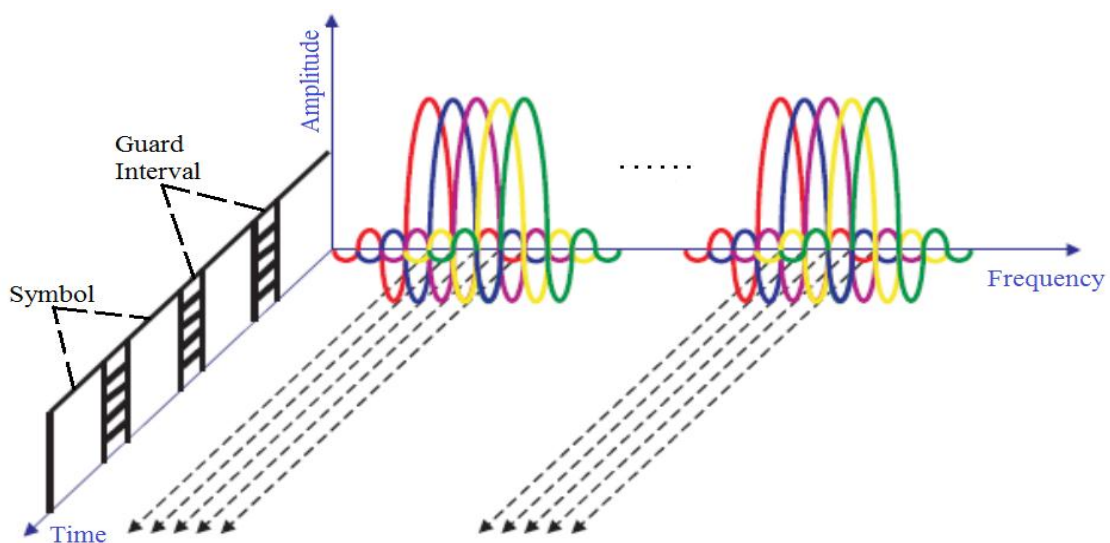

Fig. 3.1: OFDM time/frequency representation [36]

Multicarrier transmission system uses two or more modulated signals, each carry a single data stream over a communication channel. The received signals are independently demodulated in the receiver resulting in the received bit stream. OFDM is a type of Frequency Division Multiplexing (FDM) scheme that allows users to transmit information at high data rates offers a more reliable alternative to traditional single-

frequency transmission system in the noisy communication channels that suffers from fading. OFDM offers more efficient use of available RF spectrum than single-carrier frequency communication system because of simultaneous use of multiple frequencies for data communication. Guard intervals are inserted during the OFDM transmission process to preserve carrier frequency orthogonality, which reduce the potential maximal spectral efficiency of this scheme [2].

OFDM is a special form of multicarrier transmission technique, where a single data stream is transmitted over a number of lower rate modulated subcarriers. OFDM divides a given spectral allotment into many narrow subcarriers each with inherently small carrier spacing. It is a revolutionary communication technology as it forms the basis for all wireless 4G (fourth generation) communication systems [2]. One of the main reasons to use OFDM is to increase the robustness against frequency selective fading and narrowband interference. In a single carrier system, a single fade or interferer can cause failure to the entire communication system, but in a multicarrier system, only a small percentage of subcarriers will be affected. Error correction coding can then be used effectively to correct the few erroneous subcarriers.

3.1.1 Mathematical Representation of OFDM

OFDM is known as orthogonal FDM. OFDM is a special form of multicarrier transmission technique, where signal is the sum of many independent signals modulated into the number of sub-channels separated by frequency spacing of Δf .

The bandwidth will be divided into N-equally spaced subcarriers. And all the SCs are orthogonal to each other with a time interval of length $T = 1/\Delta f$. Thereby bandwidth of SCs becomes small compared to the coherent bandwidth of the channel, i.e., the individual SCs experience flat fading, which allows for simple equalization [2]. High spectral efficiency is obtained by selecting a set of orthogonal frequencies, while mutual interference among SCs can be avoided.

Let each SC can be modulated independently with the complex modulation symbol $X_{m,n}$ where m is a time index and n is subcarrier index. Then within the time interval T the following signal of the m -th OFDM block period can be described as [2]

$$x_m(t) = \frac{1}{\sqrt{N}} \sum_{n=0}^{N-1} X_{m,n} g_n(t - mT) \quad (3.1)$$

where $g_n(t)$ is

$$g_n(t) = \begin{cases} e^{j2\pi\Delta f t}, & 0 \leq t \leq T \\ 0, & \text{else} \end{cases} \quad (3.2)$$

where $g_n(t)$ is a rectangular pulse to each subcarrier. The total continuous time signal $x(t)$ consisting of the OFDM blocks is given equation

$$x_m(t) = \frac{1}{\sqrt{N}} \sum_{m=0}^{\infty} \sum_{n=0}^{N-1} X_{m,n} g_n(t - mT) \quad (3.3)$$

Now, consider a single OFDM symbol ($m = 0$) without loss of generality. This can be shown because there is no overlap between different OFDM systems. Since $m = 0$, $X_{m,n}$ can be replaced by X_n . The OFDM signal can be described as

$$x_m(t) = \frac{1}{\sqrt{N}} \sum_{n=0}^{N-1} X_n e^{j2\pi n \Delta f t} \quad (3.4)$$

If the bandwidth of OFDM signal is $B = N \times \Delta f$ and the signal $x(t)$ is sampled by the sampling time of $\Delta t = \frac{1}{N\Delta f}$, then the complex baseband OFDM signal in discrete time form can be written as [2]

$$x_k(t) = \frac{1}{\sqrt{N}} \sum_{n=0}^{N-1} X_n e^{j2\pi k n / N} \quad k = 0, 1, \dots, N-1 \quad (3.5)$$

where $n =$ index in frequency domain

$X_n =$ complex symbol frequency domain

At the receiver, the received OFDM signal is mixed with local oscillator signal, with the frequency offset deviated from Δf the carrier frequency of the received signal owing to frequency estimation error or Doppler velocity, the received signal is given by

$$\widehat{x}_k = (x_k \otimes h_k) e^{j2\pi k \Delta f T} + z_k \quad (3.6)$$

where, h_n , $e^{j2\pi k f T}$ and z_k represent the channel impulse response, the corresponding frequency offset of received signal at the sampling instants: Δf , T is the frequency offset to subcarrier frequency spacing ratio, and the AWGN respectively, \otimes while denotes the circular convolution. Assuming that a cyclic prefix is employed, the receiver have perfect time synchronization. Note that a DFT of the convolution of two signals in time domain is equivalent to the multiplication of the corresponding signals

in the frequency domain. Then the output of the FFT in frequency domain signal on the k_{th} receiving subcarrier becomes:

$$\begin{aligned}\hat{X}_m &= \sum_{n=0}^{N-1} X_n H_n Y_{n-m} + Z_m & m = 0, 1, \dots, N-1 \\ &= X_m H_m U_0 + \sum_{n=0, n \neq m}^{N-1} X_n H_n Y_{n-m} + Z_m\end{aligned}\quad (3.7)$$

The first term of Equation (3.7) is a desired transmitted data symbol X_m . The second term represents the ICI from the undesired data symbols on other subcarriers in OFDM symbol. H_m is the channel frequency response and Z_m denotes the frequency domain of z_n . The term Y_{n-m} is the coefficient of FFT (IFFT), is given by:

$$Y_{l-m} = \frac{1}{N} \sum_{n=0}^{N-1} e^{j \frac{2\pi}{N} n(l-m+\Delta f T)} \quad (3.8)$$

when the channel is flat, Y_{n-m} can be considered as a complex weighting function of the transmitted data symbols in frequency domain [37].

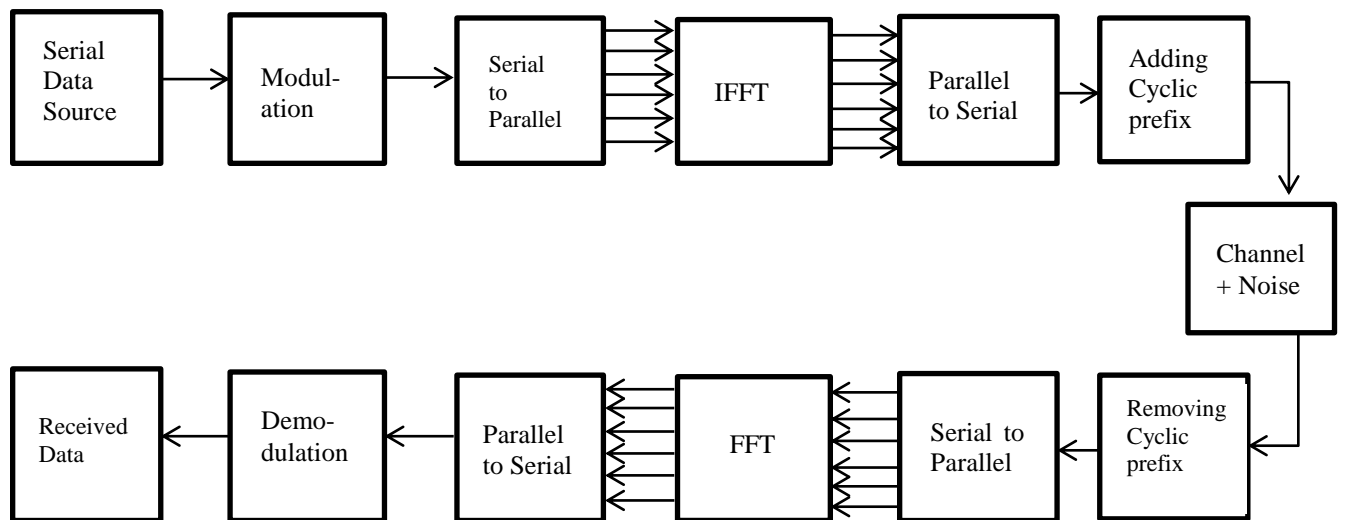

Fig. 3.2: Basic OFDM transceiver

3.1.2 IFFT and FFT Implementation

Inverse DFT and DFT are critical in the implementation of an OFDM system.

$$\text{IDFT} \quad x(n) = \frac{1}{N} \sum_{k=0}^{N-1} X(k) e^{j \frac{2\pi}{N} kn} \quad (3.9)$$

$$\text{DFT} \quad X(k) = \sum_{n=0}^{N-1} x(n) e^{-j \frac{2\pi}{N} kn} \quad (3.10)$$

N-point inverse DFT and DFT requires N^2 multiplications and additions. But taking advantage of cyclic property of the multiplier $e^{-j2\pi nk/N}$, FFT technique reduces the number of computations to the order of $N \log N$ [36]. The FFT is most efficient when N is a power of 2. It is common to add symbols of value zero to the input data block, if the number of SCs is not a power of 2, so that the advantage of using such a block length in FFT is achieved. Let $\{X_k\}_{k=0}^{N-1}$ be the complex symbols to be transmitted by OFDM modulation of the OFDM signal can be expressed as

$$\begin{aligned} x(t) &= \sum_{k=0}^{N-1} X_k e^{j2\pi f_k t} \\ &= \sum_{k=0}^{N-1} X_k \psi_k(t), \quad \text{for } 0 \leq t \leq T_s \end{aligned} \quad (3.11)$$

where $f_k = f_c + k\Delta f$

$$\text{and } \psi_k(t) = \begin{cases} e^{j2\pi f_k t}, & \text{for } 0 \leq t \leq T_s \\ 0, & \text{otherwise} \end{cases} \quad (3.12)$$

for $k = 0, 1, \dots, N-1$, T_s and Δf are called the symbol duration and SC spacing of OFDM, respectively. To demodulate OFDM signal at receiver, the symbol duration must be long enough such that $T_s \Delta f = 1$, which is also called orthogonality condition. Because of the orthogonality condition, we have [2]

$$\begin{aligned} &= \frac{1}{T_s} \int_0^{T_s} \psi_k(t) \psi_l^* dt \\ &= \frac{1}{T_s} \int_0^{T_s} e^{j2\pi(f_k - f_l)t} dt \\ &= \frac{1}{T_s} \int_0^{T_s} e^{j2\pi(k-l)t} dt \\ &= \delta(k-l) \end{aligned} \quad (3.13)$$

where $\delta(k-l)$ is a delta function defined as

$$\delta(k-l) = \delta(n) \begin{cases} 1, & \text{if } n = 0 \\ 0, & \text{otherwise} \end{cases} \quad (3.14)$$

equation (3.13) shows that $\{\psi_k(t)\}_{k=0}^{N-1}$ is a set of orthogonal functions. Using this property, the OFDM signal can be demodulated.

$$= \int_0^{T_s} x(t) e^{-j2\pi f_k t} dt$$

$$\begin{aligned}
&= \frac{1}{T_s} \int_0^{T_s} (\sum_{l=0}^{N-1} x_l \psi_l(t)) \psi_k^* dt \\
&= \sum_{l=0}^{N-1} x_l \delta(k-l) \\
&= X_k
\end{aligned} \tag{3.15}$$

this shows that for OFDM IFFT and FFT can be applied for modulation as well as demodulation. [2]

3.1.3 OFDM with a cyclic prefix

The CP is the most common GI. The GI is introduced initially to eliminate the ISI. There are several options for GI. One choice of GI is zero padding. In this scheme, no waveform is transmitted in the GI duration. However, the zero-padded waveform would destroy the orthogonality of SCs and results in ICI [36]. The CP is a good substitute of the zero-padding GI. In the CP scheme, the GI is a copy of the partial waveform. Based on the fact that the Fourier bases are periodic functions, the orthogonality of subcarriers can be preserved consequently.

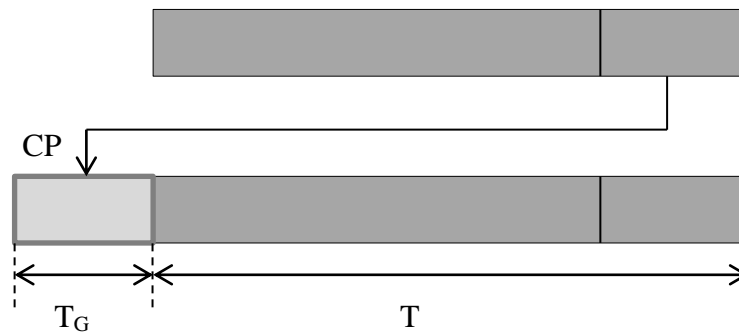

Fig. 3.3 Generate Cyclic Prefix

The cyclic prefix has two important benefits [36]:

- The cyclic prefix acts as a guard interval. It eliminates the ISI from the previous symbol.
- It acts as a repetition of the end of the symbol thus allowing the linear convolution of a frequency-selective multipath channel to be modeled as circular convolution which in turn may be transformed to the frequency domain using a discrete Fourier transform. This approach allows for simple frequency-domain processing such as channel estimation and equalization.

3.2 Applications

The previous section gives the brief introduction to the OFDM system, it should be noted that depending on the application and medium used different design issues take precedence. In this section, some of the current and future applications of OFDM systems are elaborated. OFDM takes its place in the next generation of communication systems because of its high data rates and low complexity [2].

3.2.1 IEEE 802.11

One of the most common uses of OFDM is to facilitate high-speed Wireless Local Area Networks (WLAN). One of the most popular WLAN standards in use today is the Institute of Electrical and Electronics Engineers, Inc. IEEE 802.11 standard and its variations. 802.11 actually refer to a family of specifications developed by the IEEE for WLAN technology which was accepted by the IEEE in 1997.

3.2.1.1 IEEE802.11a

An extension of the IEEE 802.11 standard is 802.11a formally written as IEEE 802.11a, which uses OFDM and operates in the 5 GHz band. The OFDM transceiver system used in this standard is capable of transferring data at 6, 9, 12, 18, 24, 36, 48, and 54 Mbps. 52 sub-carriers are used and the array of transfer rates possible is because the data symbols associated with these sub-carriers may use binary or quadrature phase shift keying (BPSK/QPSK), 16-quadrature amplitude modulation (QAM), or 64-QAM. Forward Error Correction is used at the receiver to correct any errors that may have occurred in the received and demodulated sequence of binary values.

3.2.1.2 IEEE802.11b

The 802.11b standard formally written as IEEE 802.11b was approved by the IEEE in 1999. The physical layer for this particular standard does not involve the use of OFDM but serves as a useful introduction to the two OFDM-based standards, IEEE 802.11a and IEEE 802.11g, which both use OFDM. This 802.11b standard, which uses Frequency Hopping Spread Spectrum (FHSS) or Direct Sequence Spread Spectrum (DSSS), has been largely superseded by a new generation of wireless LAN devices that enabled wire-free Ethernet connections but still at a much more reduced data transfer rate than wired-Ethernet connections. This standard relates to a similar OFDM-based transceiver as a

WLAN using 802.11a except that 802.11g termed as IEEE 802.11g operates in the 2.4 GHz band. This standard also includes the same channel access and modulation scheme capabilities used for 802.11b. Therefore, 802.11g is backwards compatible with the 802.11b standard.

3.2.1.3 IEEE802.11g

This standard relates to a similar OFDM-based transceiver as a WLAN using 802.11a except that 802.11g formally written as IEEE 802.11g operates in the 2.4 GHz band. This standard also includes the same channel access and modulation scheme capabilities used for 802.11b. Therefore, 802.11g is backwards compatible with the 802.11b standard. The OFDM signal processing kernel and the 802.11b processing kernel both required access to the Digital to Analogue Converter (DAC) and the RF front-end. A soft-switch, which is a software means of selecting one of many signal paths, is used to switch between the two different kernels when required.

3.2.1.4 IEEE802.11n

The new OFDM-based wireless standard given by IEEE is the 802.11n termed as IEEE802.11n, which is an example of how OFDM is the key to achieve significantly faster data rates than previous commercial offerings. This standard combines OFDM and Multiple Input Multiple Output (MIMO) technology. A MIMO system, which is a space-diversity transmission scheme, uses two or more antennas for transmission and reception creating two or more independent transmission paths. Information may then be transmitted in parallel using these independent transmission paths. An 802.11n implementation using an array of four antennas for transmission and reception of an OFDM signal, using a modulation scheme with a high bit to symbol ratio such as 64-QAM, means that data rates up to 600 Mbps can be achieved.

3.2.2 Digital Audio Broadcasting

DAB using OFDM has been standardized in Europe [38]. Moreover, it is the next step in evolution beyond FM radio broadcasting providing interference free transmission. The standard for DAB is known as Eureka-147 [39] and is a multi-service digital broadcasting method transmitting at around 1.5Mbps in the 1.536MHz band. In DAB between 192 and 1536 carriers are used with Differential Quadrature Phase Shift Keying (DQPSK), which allows the system to avoid channel estimation techniques. The very long symbol time

means that large echoes can be tolerated and that the redundancy due to the CP is not that great. Large echoes are expected as the broadcasting is over large distances so that long delay paths will be present. The PAPR is a problem but as DAB only uses DQPSK modulation it is more immune to noise generated through saturation of the amplifier. The DAB data payload contains audio, data associated with audio, and other optional data services.

3.2.3 Digital Video Broadcasting

Digital Video Broadcasting (DVB) [40, 41] is also using OFDM as the carrier modulation scheme. DVB delivers full multimedia in digital form in a broadcast format. DVB adapts the baseband TV signal from the output of the MPEG-2 [42] transport multiplexer to the terrestrial channel characteristics. Maximum spectral efficiency is achieved within the VHF and UHF bands by utilizing Single Frequency Network (SFN) operation. There are two modes defined in DVB: 1/2K mode and 2/8K mode. The 2K mode is used for limited distance transmission for single transmitters and small SFN's. The 8K mode encompasses the 2K mode as well as larger SFN's. One of the advantages of OFDM is that different mapping types can be used on different subcarriers, this aspect is used in DVB so that the data rate can be increased.

3.2.4 Asynchronous Digital Subscriber Lines

ADSL utilizes OFDM over wired links [43]. Data rates for ADSL standard [44] are 1.54Mbps to 6.1Mbps in the downlink and 9.6 to 192Kbps in the uplink over ordinary twisted pair telephone line upto several kilometres, while still supporting the standard telephone. The unbalanced data rates make ADSL particularly applicable to internet type applications where the downlink rate is typically much larger than the uplink rate. Stationary channels like wired links do not change over time, therefore a technique called bit loading is used. Bit loading assigns a mapping type to SCs depending on its quality, using the available bandwidth efficiently. Bit loading used in conjunction with OFDM over wired links is usually called Discrete Multi Tone (DMT).

3.3 Advantages of OFDM Transmission

- OFDM is an efficient transmission scheme to deal with multipath; for a given delay spread, addition of guard band almost removes the ISI and ICI in the system.

- As it is evident from the spectral pattern of an OFDM system, orthogonally placing the sub-carriers lead to high spectral efficiency [36].
- Conversion of the channel into many narrowly spaced orthogonal sub-carriers renders it immune to frequency selective fading.
- OFDM makes single-frequency networks possible, which is especially attractive for broadcasting applications.

3.4 Disadvantages of OFDM Transmission

3.4.1 Orthogonality

As seen above the fact to have several carriers is actually advantageous whenever they are mathematically orthogonal. So carrier's orthogonality is a constraint that can lead to a wrong operation of OFDM systems if not respected. The orthogonality is provided by IFFT that a numerical manipulation, an error of computation could change slightly spacing between two consecutive carriers and break the orthogonality of the whole system. In this case OFDM loses all its efficiency, because the notion of orthogonality is an absolute one.

3.4.2 Synchronization [36]

Both time and frequency synchronization are a major drawback in OFDM, the following sections detail the problem and provide a basic introduction into solutions for these problems.

Timing errors

Timing synchronization is the process of finding the start of a symbol in the receiver. If there is timing mismatch within the CP the demodulation produces a linear phase rotation at the output of the FFT which can be corrected with a channel estimator.

$$\hat{x}_b = \sum_{k=0}^{N-1} a[k] e^{j2\pi[k\Delta f t + (f_c + k\Delta f)\delta t]} \quad (3.16)$$

where

$$\widehat{a}_{\delta t}[k] = a[k] e^{j2\pi(f_c + n\Delta f)\delta t} \quad (3.17)$$

is the phase shift.

If the timing mismatch is not corrected additional ISI is generated. Therefore a sufficient length of the CP needs to be chosen.

Carrier phase noise

Carrier phase noise is caused by a mismatch in the RF oscillators in the transmitter and local oscillators at receiver and manifests itself in the baseband as additional phase rotation and amplitude attenuation. No difference can be made between phase rotations introduced by timing errors and carrier phase offset. The effect of phase noise is more pronounced in differential detection schemes than coherent detection schemes [45].

Frequency errors

OFDM system can be subject to two types of frequency error. They are frequency offset (as might be caused by mismatch between the RF oscillators, Doppler shifts, and phase noise introduced by non-linear channels) and, Error in the receiver master clock frequency (which will cause the spacing of the demodulating carriers to be different from those transmitted). Frequency offset causes the received signal not to be sampled at the peak, this means that the sample under consideration is not at maximum power. Power from adjacent subcarriers is also sampled as well. OFDM is more sensitive to frequency offset errors than single carrier systems due to the tight orthogonal packing of the subcarriers.

3.4.3 PAPR in OFDM

The peak power is defined as the power of a sine wave with amplitude equal to the maximum envelope value. When numerous sinusoidal waves of different frequencies and phases are added constructively or destructively, the output signal fluctuates with high PAPR. PAPR increases as number of carrier increases. The PAPR is the relation between the maximum power of a sample in a given OFDM transmit symbol divided by the average power of that OFDM symbol. The PAPR can be defined as [2]

$$PAPR = \frac{\max |x(n)|^2}{E\{|x(n)|^2\}} \quad (3.18)$$

where $E[.]$ is the expectation operator.

High PAPR value has some disadvantages for practical implementations and needs to be reduced to an acceptable level. High PAPR degrades OFDM signals by forcing the analog

amplifier to work in the nonlinear region, distorting this way the signal and making the amplifier to consume more power.

CHAPTER 4

PAPR AND SLM

4.1 Introduction

OFDM is one of the many multicarrier modulation techniques, which provides high spectral efficiency, low implementation complexity, less vulnerability to echoes and non-linear distortion. Due to these advantages of the OFDM system, it is vastly used in various communication systems. But the major problem one faces while implementing this system is the high PAPR of this system. A large PAPR increases the complexity of the ADC and DAC, used at transmitter and receiver respectively, and reduces the efficiency of the RF power amplifier.

Regulatory and application constraints can be implemented to reduce the peak transmitted power which in turn reduces the range of multi carrier transmission. This leads to the prevention of spectral growth and the transmitter power amplifier is no longer confined to linear region in which it should operate for distortionless amplification. This has a harmful effect on the battery lifetime of the apparatus used for multicarrier communication. Therefore it is vital for the multicarrier communication system to reduce the PAPR.

There have been many new approaches developed during the last few years. Several PAPR reduction techniques have been proposed in the literature. These techniques are divided into two groups. These are signal scrambling techniques and signal distortion techniques. These techniques achieve PAPR reduction at the expense of transmit signal power increase BER increase, data rate loss, computational complexity increase, and so on [46]. The signal scrambling techniques are

- Block coding
- SLM
- Partial Transmit Sequences
- Tone Reservation
- Tone Injection
- Active Constellation Extension

Signal scrambling techniques work with side information which minimized the effective throughput since they commence redundancy. Signal distortion techniques introduce band interference and system complexity also. These techniques reduce the peak amplitudes simply by nonlinearly distorting the OFDM signal at or around the peaks. These techniques minimize high peak dramatically by distorting signal before amplification. The signal distortion techniques are:

- Clipping and Filtering
- Peak windowing
- Envelope Scaling
- Peak Reduction Carriers
- Nonlinear Comanding Scheme

Both types of PAPR reduction techniques have been discussed in previous chapter, in this chapter SLM Scheme which comes under Signal Scrambling Techniques is discussed, but first analyses the PAPR distribution function. This will give a better insight in the PAPR problem and will explain why PAPR reduction techniques can be quite effective.

4.2 PAPR

An OFDM signal consists of a number of independently modulated SCs, these when added up coherently gives a large PAPR. When N signals are added with the same phase, they produce a peak power that is N times the average power. This effect is illustrated in Fig. 4.1. For this example, the peak power is 16 times the average value. The peak power is defined as the power of a sine wave with amplitude equal to the maximum envelope value. Hence, an unmodulated carrier has a PAPR of 0 dB. An alternative measure of the envelope variation of a signal is the Crest factor, which is defined as the maximum signal value divided by the RMS signal value.

$$C = \frac{\max |x(n)|}{x_{rms}} \quad (4.1)$$

The relationship between Crest factor and PAPR is given by

$$C = \sqrt{PAPR} \quad (4.2)$$

hence, PAPR is given by

1/2. The amplitude of the OFDM signal therefore has a Rayleigh distribution, while the power distribution becomes a central chi-square distribution with two degrees of freedom and zero mean with a cumulative distribution given by

$$F(z) = 1 - e^{-z} \quad (4.5)$$

The CDF is one of the most regularly used parameters, which is used to measure the efficiency of any PAPR technique. Normally, the Complementary Cumulative Distribution Function (CCDF) is used instead of CDF, which helps us to measure the probability that the PAPR of a certain data block exceeds the given threshold. To derive the CDF for the peak power per OFDM symbol, assuming the samples are mutually uncorrelated, which is true for non over sampling, the probability that the PAPR is below some threshold level can be written as

$$P(\text{PAPR} \leq z) = F(z)^N = (1 - e^{-z})^N \quad (4.6)$$

There are different approaches to the PAPR problem is to use the fact that because large PAP ratios occur only infrequently, it is possible to remove these peaks at the cost of a slight amount of self-interference. Now, the challenge is to keep the spectral pollution of this self-interference as small as possible.

4.3 Selected Mapping Technique

The SLM technique is derived from the idea of symbol scrambling. In the SLM technique, the transmitter generates a set of different data blocks, all representing the same information as the original data block and selects the most favourable for transmission [47]. This is an effective and distortion less technique used for the PAPR reduction in OFDM. According to the concept of discrete time OFDM transmission we should make a data block considering N number of symbols from the constellation plot, where N is the number of SCs to be used. Then using the data block, U number of independent candidate vectors are to be generated with the multiplication of independent phase vectors. Let us consider the data block with $X(k)$ as the mapped symbol (i.e. the symbol from the constellation), where $k = \{0, 1, 2, \dots, N - 1\}$. Let the u^{th} phase vector is denoted as $B^{(u)}$, where $u = \{1, 2, \dots, U\}$. The u^{th} candidate vector that is generated by the multiplication of data block with the phase vector is denoted as $X^{(u)}$. So we can write the equation to get the k^{th} element of u^{th} candidate vector as

$$X^u(k) = X(k)B^{(u)}(k) \quad (4.7)$$

Then by doing IFFT operation to each candidate vector we will obtain U number of alternative OFDM signals, so the n^{th} symbol of u^{th} alternative OFDM signal can be written mathematically as

$$x^{(u)}(n) = \frac{1}{\sqrt{N}} \sum_{k=0}^{N-1} X^u(k) e^{j\left(\frac{2\pi nk}{N}\right)} \quad (4.8)$$

So out of the U number of alternative OFDM signals the signal having minimum PAPR is to be selected for transmission. Let that selected OFDM signal is denoted as $x^{(\hat{u})}(k)$. The block diagram for this technique is shown in figure 4.2.

So in this technique for generation of alternative OFDM symbols the independent phase vectors has to generate. We get from the equation 4.7, the k^{th} value of u^{th} phase vector is denoted as $B^{(u)}(k)$ and can be found by

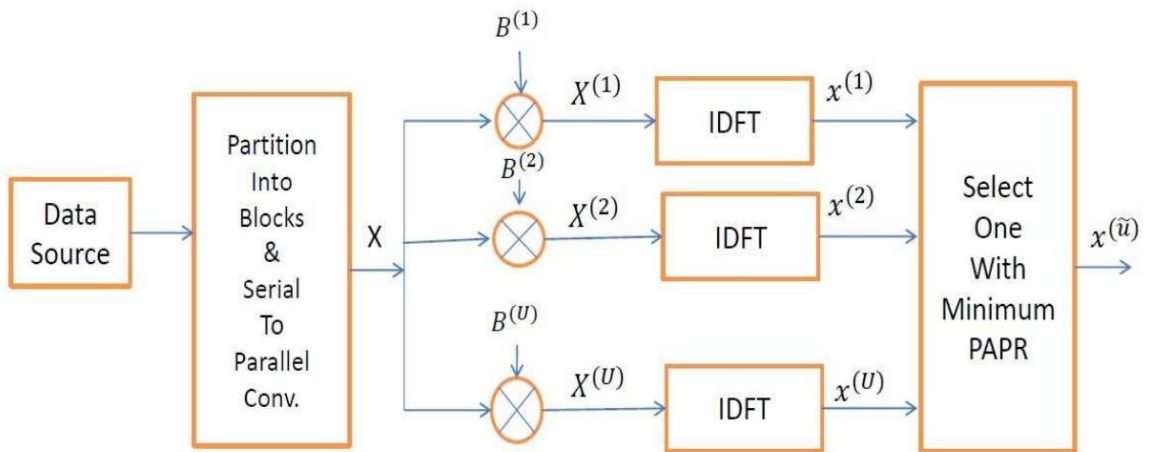

Fig. 4.2: Block Diagram of SLM[9]

$$B^{(u)}(k) = e^{j\varphi^{(u)}(k)} \quad (4.9)$$

where $\varphi(k)$ is the random phase value. So from the equation 4 we get that $X^{(u)}(k)$ be a phase rotated version of $X(k)$. From [48] we came to know that two phase vectors $B^{(m)}$ and $B^{(l)}$ is dependent if any joint cumulant between them is nonzero. So the condition of mutual independence between $b^{(m)}(n)$ and $b^{(l)}(n)$ is given as

$$E[e^{j\varphi}] = 0 \quad (4.10)$$

To make satisfy the above condition φ should be uniformly distributed in $[0, 2\pi)$. According to this selection criteria of φ the variation of the PAPR reduction performance will be shown in the next subsection.

The figure 4.2 provides description about the transmitter side of the SLM technique. This selected OFDM signal at transmitter side has to be recovered at the receiver side. So the receiver side must have the information about the perfect phase vector that has been used to generate that selected OFDM signal. Hence to fulfil the requirement of the receiver some side information (SI) has to be transmitted along with the selected OFDM signal. This SI index is generally transmitted as a set of $\lceil \log_2 U \rceil$ bits. For the efficient transmission of these extra bits channel coding technique should be used. If any SI index cannot be detected properly then that total recovered transmitted block will be in error.

CHAPTER 5

DIGITAL MODULATION

5.1 Introduction

Modulation is the process of encoding information from a message source in a manner suitable for transmission. In general it involves translating a baseband signal (source signal) to a modulated signal at a higher frequency (the carrier frequency, f_c). In a digital communication system, the source signal to be transmitted is discrete both in time and amplitude. In digital modulation, an analog carrier signal is modulated by a discrete signal. Digital modulation methods can be considered as digital-to-analog conversion, and the corresponding demodulation or detection as analog-to-digital conversion. The changes in the carrier signal are chosen from a finite number of M alternative symbols (the modulation alphabet). There are number of advantages of digital modulation over analog modulation.

- Greater noise immunity and robustness to channel impairments.
- Easier multiplexing of various forms of information like voice, data, video.
- Greater security – by using coding techniques to avoid jamming.
- Accommodation of digital error control codes which detect and/or correct transmission errors.
- Equalization to improve the performance of overall communication link.
- Supports complex signal conditioning and processing methods.

Digital modulation can be classified into number of categories depending on process whereby the amplitude, frequency, phase or a combination of them is varied in accordance with the information to be transmitted. The most common digital modulation techniques are:

- Phase Shift Keying (PSK)
- Frequency Shift Keying (FSK)
- Amplitude Shift Keying (ASK)
- Quadrature Amplitude Modulation (QAM)
- Continuous Phase Modulation (CPM)
- Spread Spectrum techniques

In this dissertation, PSK, $\pi/4$ –DQPSK and GMSK are implemented

5.2 Phase Shift Keying

Phase Shift Keying (PSK) is digital modulation technique that conveys data by changing or modulating the phase of a carrier signal. The demodulator determines the phase of the received signal and maps it back to the symbol it represents. PSK has constant envelop, this leaves the requirements of transmitter power amplifier. PSK is more bandwidth efficient than FSK, and more power efficient than ASK and FSK. PSK is of number of types some of them are

- Binary PSK (BPSK), using M=2 symbols
- Quadrature PSK (QPSK), using M=4 symbols
- 8PSK, using M=8 symbols
- 16PSK, using M=16 symbols
- Differential PSK (DPSK)
- Differential QPSK (DQPSK)
- Offset QPSK (OQPSK)
- $\pi/4$ –QPSK
- $\pi/4$ –DQPSK

In this dissertation, under PSK modulation PSK with M=16, 64 and $\pi/4$ –Differential Quadrature Phase Shift Keying ($\pi/4$ –DQPSK) are implemented in OFDM systems.

5.3 MPSK

In MPSK, M stands for number of symbols used in PSK modulation. The reason for using MPSK is to increase the bandwidth efficiency of PSK. For MPSK, the modulated signal is defined as[49]

$$\begin{aligned}
 s_i(t) &= Ag(t) \cos(2\pi f_c t + \theta_i), & 0 \leq t \leq T \quad i = 0, 1, \dots, M - 1 \\
 &= A \cos \theta_i g(t) \cos(2\pi f_c t) + A \sin \theta_i g(t) \sin(2\pi f_c t) \\
 &= s_i^I g(t) \cos(2\pi f_c t) + s_i^Q g(t) \sin(2\pi f_c t)
 \end{aligned} \tag{5.1}$$

where $\theta_i = \frac{2\pi i}{M}$,

$$A = \sqrt{E_s},$$

$$s_i^I = A \cos \theta_i,$$

$$s_i^Q = A \sin \theta_i \text{ and}$$

$g(t)$ is the pulse shaping function given by $g(t) = \sqrt{\frac{2}{T}}$, $0 \leq t \leq T$ or any function, which satisfy orthonormal conditions

$$\int_0^T g^2(t) \cos^2(2\pi f_c t) dt = 1 \quad (5.2)$$

$$\int_0^T g^2(t) \cos(2\pi f_c t) \sin(2\pi f_c t) dt = 0 \quad (5.3)$$

f_c = carrier frequency is selected as an integer multiple of symbol rate, thus the signal initial phase in any symbol interval is one of the M phases, θ_i

In MPSK the minimum distance between the two constellations points on the signal constellation diagram

$$d_{min} = 2A \sin\left(\frac{\pi}{M}\right) \quad (5.4)$$

In the signal constellation diagram of MPSK, there are M points uniformly distributed on a unit circle, each point corresponding a possible value of the symbol. Gray code is used for symbol representation such that adjacent signal points differ by only one bit. the advantage of using Gray code is that a symbol error is most likely to cause a single bit error. The constellations of Gray coded QPSK and 8PSK are shown in Fig.5.1.

Bit error probability for MPSK is

$$P_b = \frac{2}{\log_2 M} \sum_{i=1}^{M/4} Q\left(\sqrt{\frac{2E_b \log_2 M}{N_0} \sin\left(\frac{(2i-1)\pi}{M}\right)}\right) \quad (5.5)$$

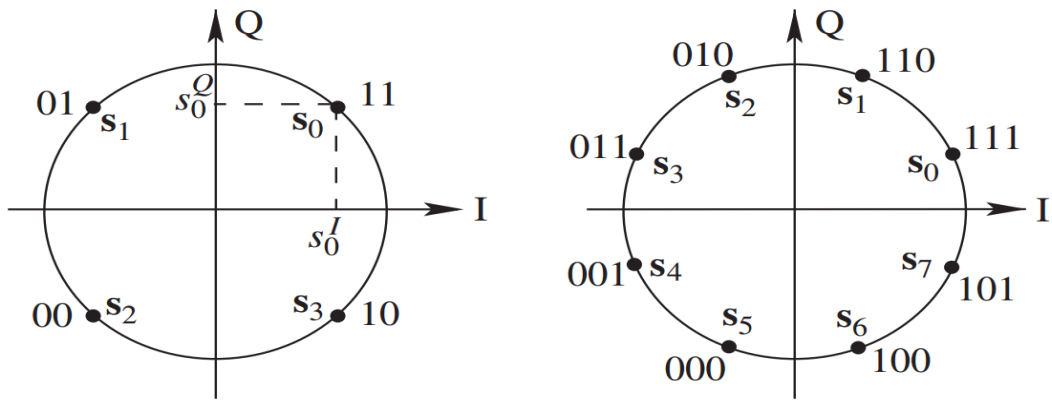

Fig. 5.1: MPSK constellations. (a) QPSK. (b) 8PSK [49]

Since MPSK signals are two-dimensional, for $M \geq 4$, the modulator can be implemented by a quadrature modulator. The MPSK modulator is shown in Fig. 5.2

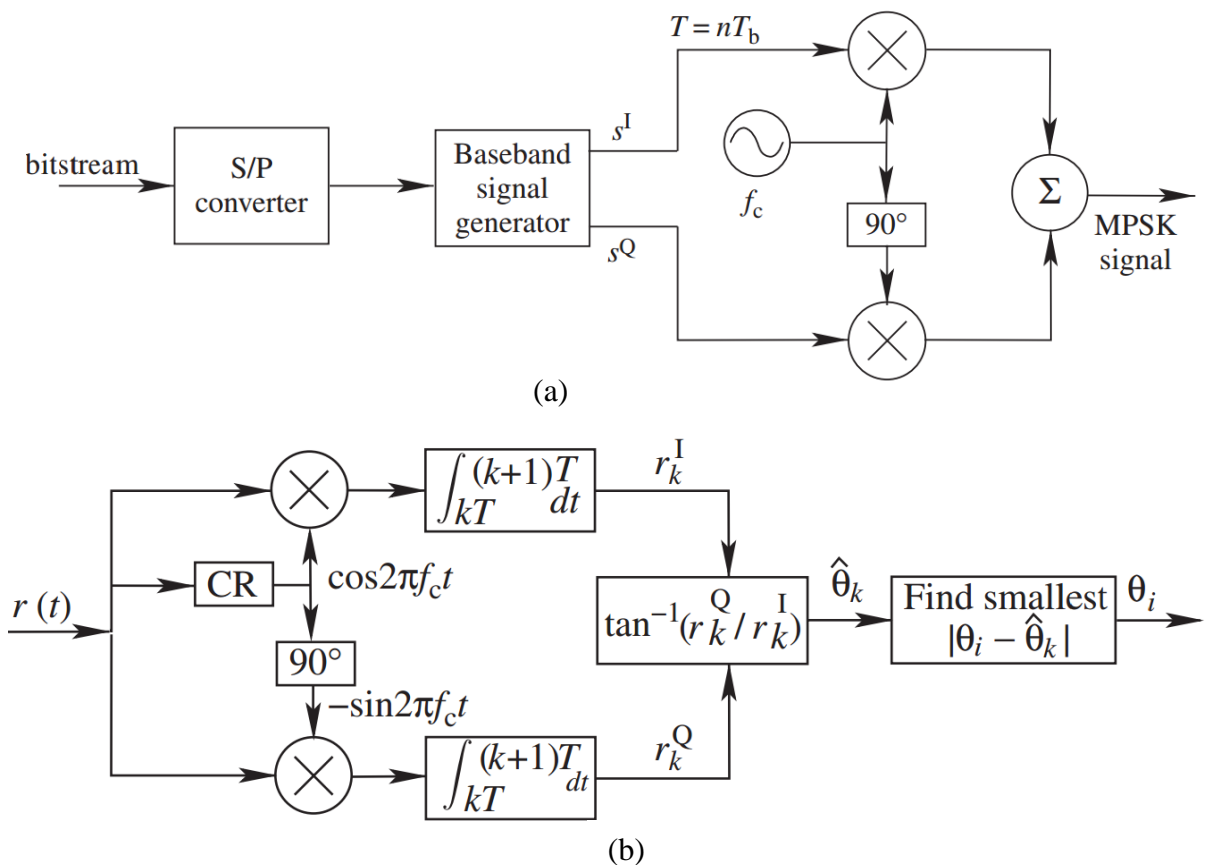

Fig. 5.2: MPSK (a) modulator (b) Coherent MPSK demodulator. CR denotes coherent reference. [49]

Coherent MPSK demodulation uses two correlators, and a carrier recovery circuit is used to get the reference signal. At the receiver, the received signal is

$$r(t) = s(t) + n(t) \quad (5.6)$$

where $n(t)$ is the AWGN channel noise. The structure of coherent MPSK demodulator is shown

5.4 $\pi/4$ –DQPSK

When the phase is differentially encoded, the demodulator then determines the changes in the phase of the received signal rather than the phase itself. This is known as DQPSK. In $\pi/4$ –QPSK modulation, modulated signal points are alternatively selected from two QPSK constellations that have a phase difference of $\pi/4$. The $\pi/4$ –DQPSK modulation combines differential encoding with $\pi/4$ –QPSK. For each symbol, the modulated signal has a phase shift which is that of the previous symbol plus a nonzero phase shift. The nonzero phase shift has four states, corresponding to the four possible values of a symbol. In $\pi/4$ –DQPSK modulation, there are much smaller fluctuations of the envelope than that of QPSK because the transitions between subsequent signal constellations never pass through the origin.

The constellation of $\pi/4$ – QPSK and $\pi/4$ – DQPSK modulation is also shown in Fig. 6. For $\pi/4$ – DQPSK with Gray codes, bit error probability is quite complicated

$$P_b = Q(a, b) - \frac{1}{2} I_0(ab) e^{-\frac{1}{2}(a^2+b^2)} \quad (5.7)$$

where I_0 is the zero-order modified Bessel function of the first kind, which is given by

$$I_0(x) = \frac{1}{2\pi} \int_0^{2\pi} e^{-x \cos \theta} d\theta \quad (5.8)$$

$$a = \sqrt{2\gamma_b \left(1 - \frac{1}{\sqrt{2}}\right)}, \quad b = \sqrt{2\gamma_b \left(1 + \frac{1}{\sqrt{2}}\right)}$$

and

$$Q(a, b) = 1 - \int_0^b z e^{-\frac{z^2+a^2}{2}} I_0(za) dz$$

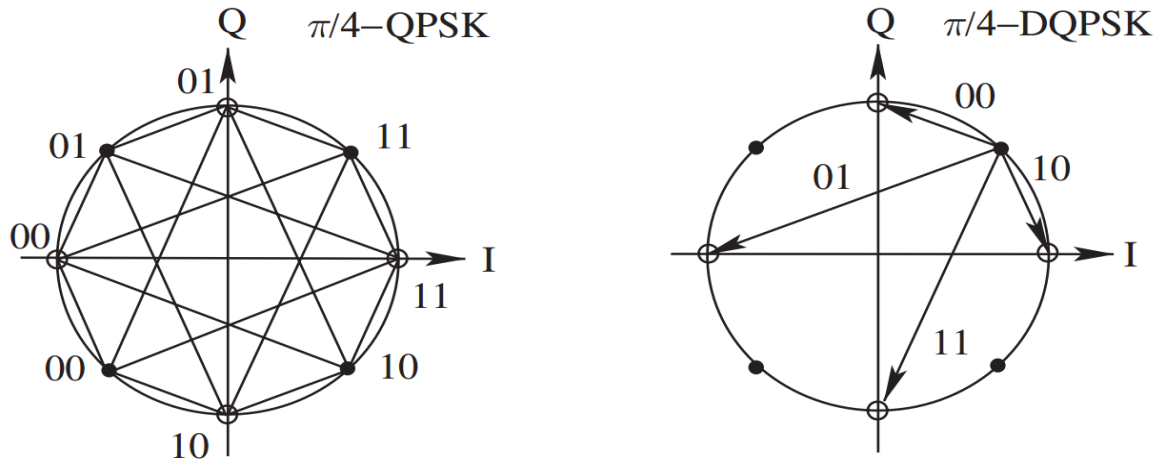

Fig. 5.3: Constellations of $\pi/4 - \text{QPSK}$ and $\pi/4 - \text{DQPSK}$.

5.5 Gaussian Minimum Shift Keying

GMSK is a simple digital binary modulation technique which may be viewed as a derivative of Minimum Shift Keying (MSK). GMSK is a form of continuous-phase frequency shift keying in which phase is changed between symbols to provide a constant envelop. In GMSK, phase of the carrier is continuously varied by modulating signal. The important characteristics of GMSK are: constant envelop, relatively narrow bandwidth and coherent detection capability. The power spectrum of the MSK has a wide main lobe. In GMSK, the sidelobes levels of the spectrum are reduced by passing modulating NRZ data waveform through a pre-modulation Gaussian pulse shaping filter [49]. This filter has sharp narrow bandwidth and sharp cut-off properties which are required to suppress the high frequency components. However, the Gaussian filter increases the modulation memory in the system and causes inter symbol interference, making it more difficult to discriminate between different transmitted data values and requiring more complex channel equalization algorithms such as an adaptive equalizer at the receiver. GMSK is most attractive for excellent spectral efficiency and power efficiency (due to the constant envelop).

The GMSK premodulation filter has a impulse response given by

$$h_G(t) = \frac{\sqrt{\pi}}{\alpha} \exp\left(-\frac{\pi^2}{\alpha^2} t^2\right) \quad (5.9)$$

and transfer function is given as

$$H_G(f) = \exp(-\alpha^2 f^2) \quad (5.10)$$

The parameter α is related to bandwidth, B , the 3dB baseband bandwidth of $H_G(f)$

$$\alpha = \frac{\sqrt{\ln 2}}{\sqrt{2}B} = \frac{0.5887}{B}$$

and the GMSK filter can be completely defined from B and symbol duration, T , because of this it is customary to define GMSK by its BT product. As BT decreases, GMSK spectrum becomes more and more compact but leads to increase in ISI and also degradation in power efficiency. For $BT = \infty$, it reduces to MSK while smaller BT leads to tighter power spectral density.

The bit-error-probability for GMSK is given as

$$P_b = Q(\sqrt{2\alpha\gamma_b}) \quad (5.11)$$

where α is a degradation factor due to Gaussian filter, $\alpha = 0.68$ for GMSK with $BT = 0.25$, $\alpha = 0.85$ for simple MSK ($BT \rightarrow \infty$).

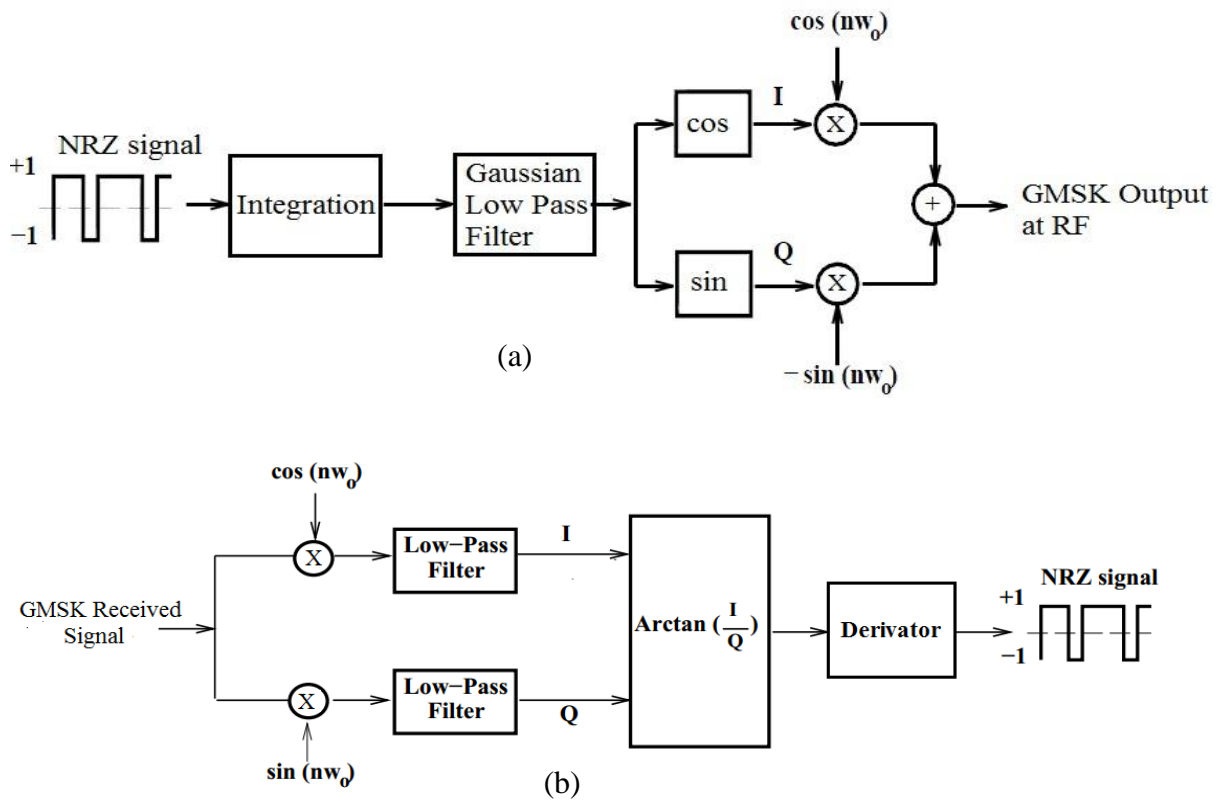

Fig. 5.4: GMSK (a) transmitter (b) receiver

The simplest way to generate GMSK signal is to pass a NRZ message bit stream through a Gaussian baseband filter having impulse response given by equation (5.9), followed by standard I/Q modulator.

The GMSK signal can be detected by orthogonal coherent detectors. The received signal is detected using I/Q demodulator followed by lowpass filters

CHAPTER 6

CHANNEL FADING AND MODELS

6.1 Fading

Fading is used to describe fluctuations in the envelope of a transmitted radio signal. Sometimes it is defined as fluctuation problem in receiving radio signals is variations in signal strength. There are several conditions that can produce fading. When a radio wave is refracted by the ionosphere or reflected from the Earth's Surface, random changes in the polarization of the wave may occur [4]. Vertically and horizontally mounted receiving antennas are designed to receive vertically and horizontally polarized waves, respectively. Therefore, changes in polarization cause changes in the received signal level because of the inability of the antenna to receive polarization changes. Fading also results from absorption of the RF energy in the ionosphere. Absorption fading occurs for a longer period than other types of fading, as absorption takes place slowly. Usually, however, fading on ionospheric circuits is mainly a result of multipath propagation.

6.2 Multipath Fading

Multipath fading affects most forms of radio communications links in one form or another. Multipath fading can be detected on many signals across the frequency spectrum from the HF bands right up to microwaves and beyond. This type of fading is experienced not only by short wave radio communications where signals fade in and out over a period of time, but it is also experienced by many other forms of radio communications systems including cellular telecommunications and many other users of the VHF and UHF spectrum[4].

Multipath fading occurs in any environment where there is multipath propagation and movement of elements within the radio communications system. This may include the radio transmitter or receiver position, or in the elements that give rise to the reflection, refraction, scattering, diffraction. Sometimes multipath fading is so severe that the signal fades away completely, whereas at other times the fading may not cause the signal to fall below a useable strength.

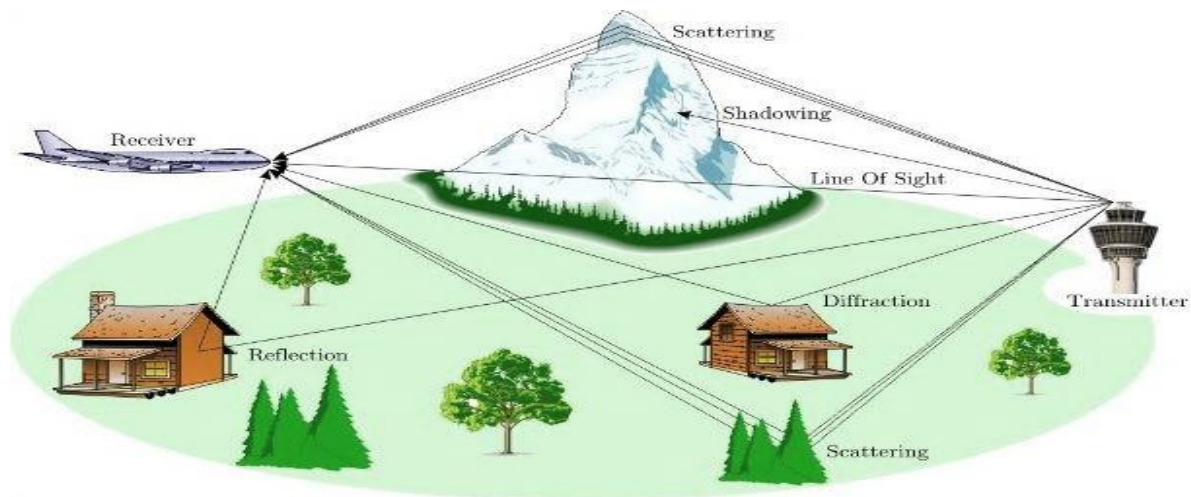

Fig. 6.1: Multipath fading channel

Multipath fading may also cause distortion to the radio signal. It is a feature that needs to be taken into account when designing or developing a radio communications system. In any terrestrial radio communications system, the signal will reach the receiver not only via the direct path, but also as a result of reflections from objects such as buildings, hills, ground, water, etc that are adjacent to the main path [4]. As the various paths that can be taken by the signals vary in length, the signal transmitted at a particular instance will arrive at the receiver over different times. The overall signal at the radio receiver is a summation of the variety of signals being received. As they all have different path lengths, the signals will add and subtract from the total dependent upon their relative phases. This can cause problems with phase distortion and ISI when data transmissions are made.

At times there will be changes in the relative path lengths. This could result from either the radio transmitter or receiver moving, or any of the objects that provides a reflective surface moving. This will result in the phases of the signals arriving at the receiver changing, and in turn this will result in the signal strength varying as a result of the different way in which the signals will sum together. It is this that causes the fading that is present on many signals.

6.2.1 Types of Multipath Fading

Propagation models have traditionally focused on predicting the average received signal strength at a given distance from the transmitter, as well as the variability of the signal

strength in close spatial proximity to a particular location. Depends upon it, the multi path fading is mainly classified into 2 types [4].

- Large scale fading
- Small scale fading

6.2.1.1 Large Scale Fading

Large-scale fading represents the average signal power attenuation or the path loss resulting from motion over large areas. This phenomenon is affected by prominent terrain contours (e.g., buildings, forests, billboards, or hills) between the transmitter and receiver. The receiver is often said to be “shadowed” by such prominences. The statistics of large-scale fading provide a way of computing an estimate of path loss as a function of distance. This is often described in terms of a mean-path loss (nth-power law) and a log normally distributed variation about the mean. Large-scale fading (attenuation or path loss) can be considered to be a spatial average over the small scale fluctuations of the signal. It is generally calculated by averaging the received signal over 10 to 30 wavelengths to decouple the small-scale (mostly Rayleigh) fluctuations from the large-scale shadowing effects (typically log normal).

6.2.1.2 Small Scale Fading

Small-scale fading refers to the dramatic changes in signal amplitude and phase that can be experienced as a result of small changes (as small as a half wavelength) in the spatial positioning between a receiver and a transmitter. Small-scale fading manifests itself in two mechanisms, which are time spreading of the signal (or signal dispersion) and time variant behaviour of the channel [4]. For mobile-radio applications, the channel is time variant because motion between the transmitter and receiver results in propagation path changes. The rate of change of these propagation conditions accounts for the fading rapidity (rate of change of the fading impairments). Small-scale fading is called Rayleigh fading if there are multiple reflective paths that are large in number, and there is no line-of-sight (LOS) signal component; the envelope of such a received signal is statistically described by a Rayleigh pdf. When there is a dominant nonfading signal component present, such as LOS propagation path, the small-scale fading envelope is described by a Rician pdf [1]. In other words, the small-scale fading statistics are said to be Rayleigh whenever the LOS path is blocked and Rician otherwise.

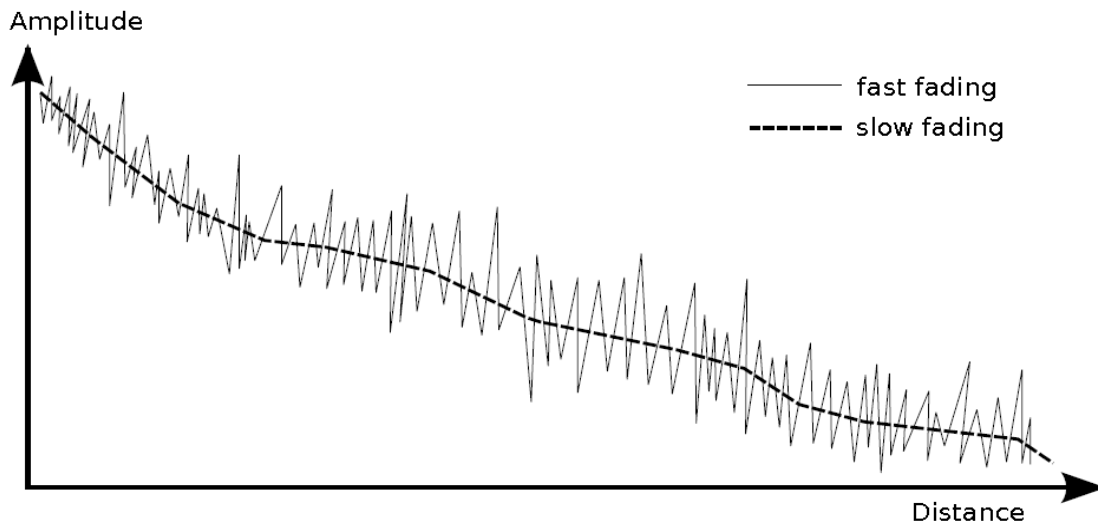

Fig. 6.2 Large scale& small scale fading [4]

In fig. 6.2, Small scale fading is superimposed on large scale fading can be easily identified. Equation 5.1 shows the relationship between large scale and small scale fading

$$\alpha(t)R(t) = m(t) \times r_0(t) \times R(t) \quad (6.1)$$

where $m(t)$ is the large scale fading component of the envelope, and $r_0(t)$ is the small scale fading component. Sometimes, $m(t)$ may be referred as the local mean or log normal fading and $r_0(t)$ is sometimes referred to as multipath or Rayleigh fading.

Depending on the relation between the signal parameters (such as bandwidth, symbol period, etc.) and the channel parameters (such as rms delay spread and Doppler spread), different transmitted signals will undergo different types of fading. The time dispersion and frequency dispersion mechanisms in a mobile radio channel lead to four possible distinct effects, which are manifested depending on the nature of the transmitted signal, the channel, and the velocity. While multipath delay spread leads to time dispersion and frequency selective fading, Doppler spread leads to frequency dispersion and time selective fading. The two propagation mechanisms are independent of one another. Fig. 6.3 shows the types of fading.

Fading effects due to multi path time delay spread

In a fading channel, the relationship between maximum delay spread time, T_m , and symbol period, T_s , can be viewed in terms of two different degradation categories, frequency-selective fading and frequency nonselective or flat fading

- Frequency selective fading
- Flat fading

Frequency Selective Fading

A channel is said to exhibit frequency-selective fading if $T_m > T_s$. This condition occurs whenever the received multipath components of a symbol extend beyond the symbol time duration. Such multipath dispersion of the signal yields the same kind of ISI distortion that is caused by an electronic filter. However, another name for this category of fading degradation is channel-induced ISI. In the case of frequency-selective fading, mitigating the distortion is possible because many of the multipath components are resolvable by the receiver.

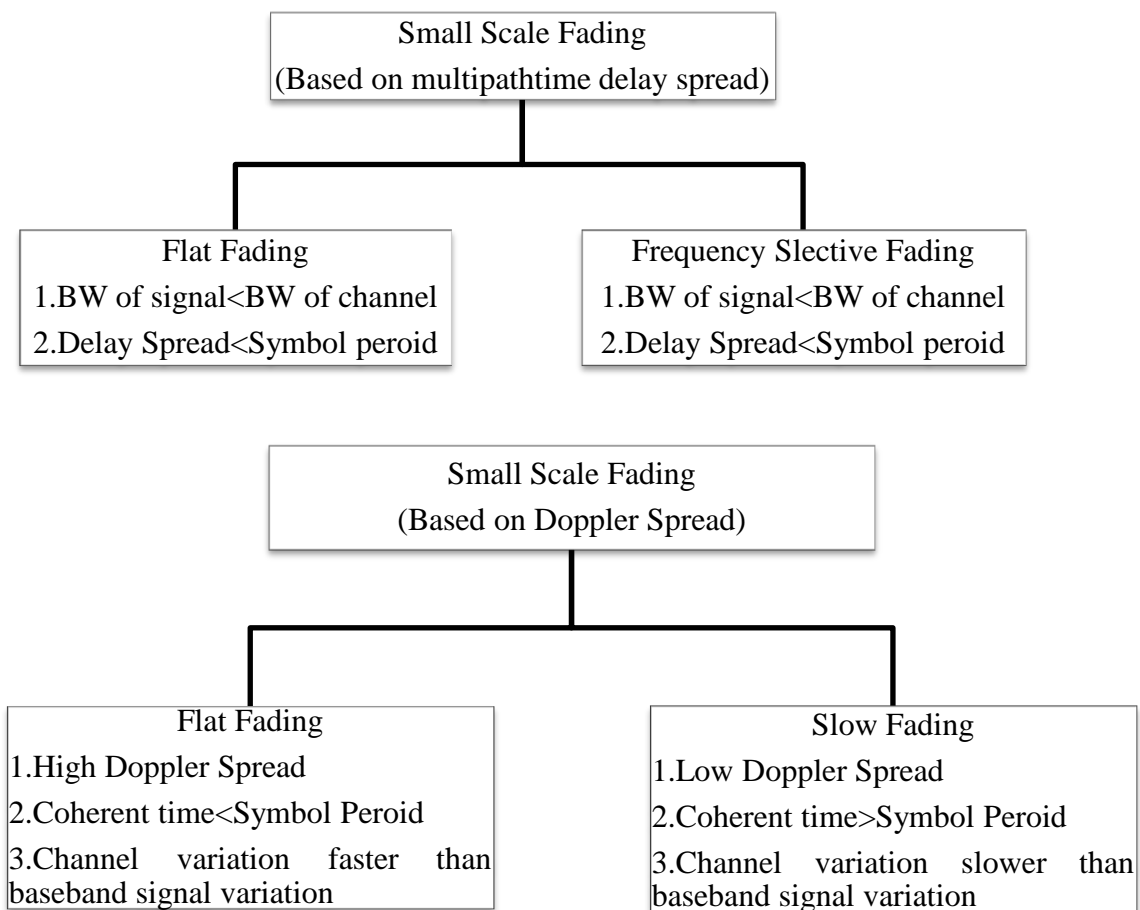

Fig. 6.3: Types of small scale fading [4]

If the channel possesses a constant-gain and linear phase response over a bandwidth that is smaller than the bandwidth of transmitted signal, then the channel creates frequency selective fading on the received signal. Under such conditions, the channel impulse

response has a multipath delay spread which is greater than the reciprocal bandwidth of the transmitted message waveform. When this occurs, the received signal includes multiple versions of the transmitted waveform which are attenuated (faded) and delayed in time, and hence the received signal is distorted.

Frequency selective fading channels are much more difficult to model than flat fading channels since each multipath signal must be modeled and the channel must be considered to be a linear filter [36]. It is for this reason that wide band multipath measurements are made, and models are developed from these measurements. When analyzing of the mobile communication systems, statistical impulse response models such as the two-ray Rayleigh fading model (which considers the impulse response to be made up of two delta functions which independently fade and have sufficient time delay between them to induce frequency selective fading upon the applied signal), or computer generated or measured impulse responses, are generally used for analyzing frequency selective small-scale fading.

Flat Fading

A channel is said to exhibit frequency nonselective or flat fading if $T_m < T_s$. In this case, all the received multipath components of a symbol arrive within the symbol time duration; hence, the components are not resolvable. In this type of fading, there is no channel-induced ISI distortion, because the signal time spreading does not result in significant overlap among neighboring received symbols. There is still performance degradation because the unresolvable phasor components can add up destructively to yield a substantial reduction in SNR. Also, signals that are classified as flat fading, can sometimes experience the distortion effects of frequency-selective fading.

This form of multipath fading affects all the frequencies across a given channel either equally or almost equally. When flat multipath fading is experienced, the signal will just change in amplitude, rising and falling over a period of time, or with movement from one position to another. In other words, if the radio channel has a constant gain and linear phase response over a bandwidth which is greater than the bandwidth of the transmitted signal, then the received signal will undergo flat fading [4]. In flat fading, the multipath structure of the channel is such that the spectral characteristics of the transmitted signal are preserved at the receiver. However the strength of the received signal changes with time, due to fluctuations in the gain of the channel caused by multipath.

Flat fading channels are also known as amplitude varying channels and are sometimes referred to as narrowband channels, since the bandwidth of the applied signal is narrow as compared to the channel flat fading bandwidth. Typical flat fading channels cause deep fades, and thus may require 20 or 30 dB more transmitter power to achieve low bit error rates during times of deep fades as compared to systems operating over non-fading channels. The distribution of the instantaneous gain of flat fading channels is important for designing radio links, and the most common amplitude distribution is the Rayleigh distribution. The Rayleigh flat fading channel model assumes that the channel induces amplitude which varies in time according to the Rayleigh distribution.

Signal Time Spreading Viewed in the Frequency Domain

A channel is referred to as frequency selective if $f_0 < 1/T_s \approx W$, where the symbol rate, $1/T_s$ is nominally taken to be equal to the signaling rate or signal bandwidth W . Frequency selective fading distortion occurs whenever signal spectral components are not all affected equally by the channel. Some of the signal spectral components, falling outside the coherence bandwidth, are affected differently (independently) compared with those components contained within the coherence bandwidth.

Fig. 6.4 contains two examples. Each one illustrates the spectral density vs. frequency of a transmitted signal having a bandwidth of W Hz. Superimposed on the plot in Fig. 6.4a is the frequency transfer function of a frequency-selective channel ($f_0 < W$). Fig. 6.4a shows that various spectral components of the transmitted signal are affected differently [4].

Frequency-nonselctive or flat-fading degradation occurs whenever coherent bandwidth $f_0 > W$. Hence, all the signal spectral components are affected by the channel in a similar manner (e.g., fading or no fading). This is illustrated in Fig. 6.4b, which features the spectral density of the same transmitted signal having a bandwidth of W Hz. However, superimposed on this plot is the frequency transfer function of a flat-fading channel ($f_0 > W$). Fig. 6.4b illustrates that all the spectral components of the transmitted signal are affected in approximately the same way. Flat fading does not introduce channel-induced ISI distortion, but performance degradation can still be expected because of the loss in SNR whenever the signal is fading. To avoid channel-induced ISI distortion, the channel is required to exhibit flat fading. This occurs provided that

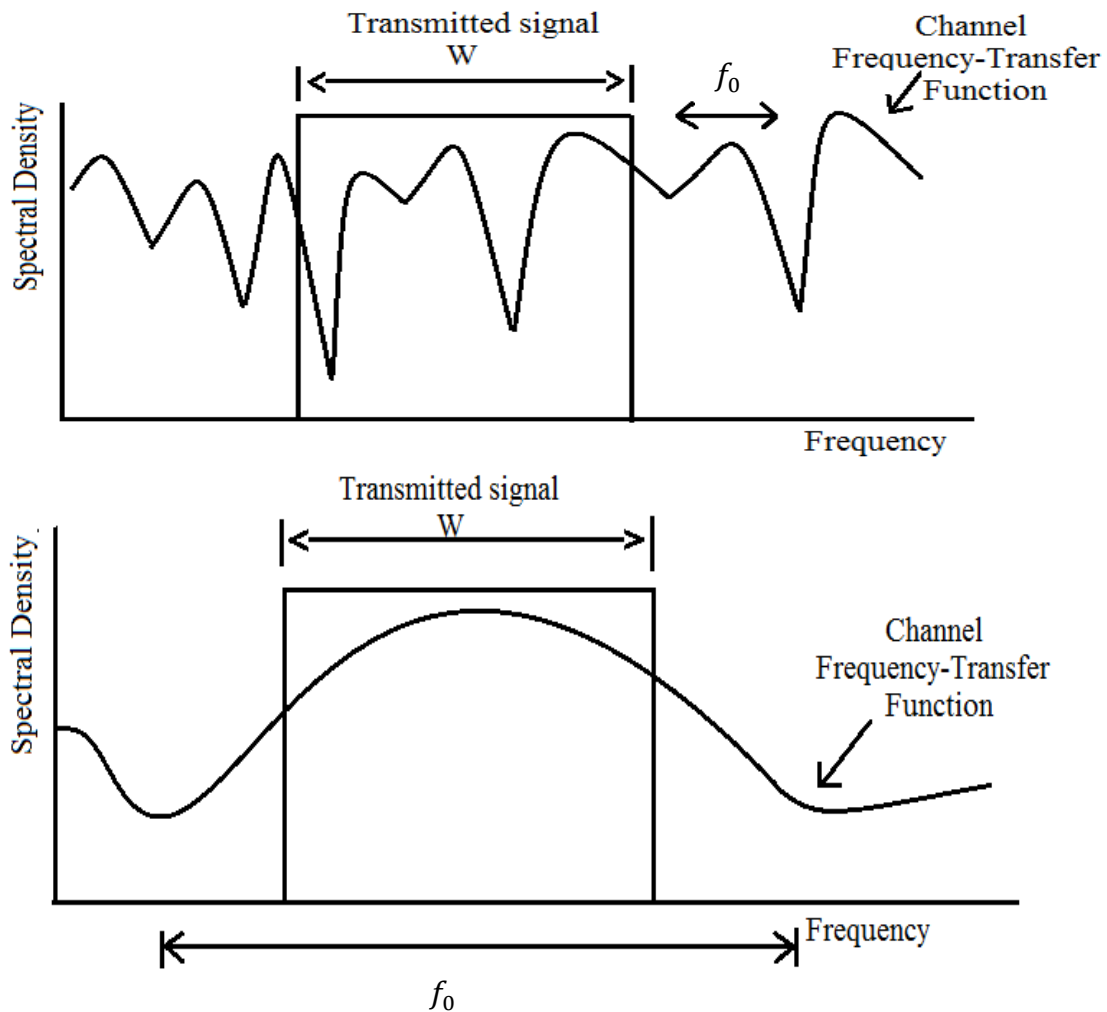

Fig. 6.4: Typical case of (a) Frequency Selective (b) Flat Fading

$$f_0 = W \approx \frac{1}{T_s} \quad (5.2)$$

Hence, the channel coherence bandwidth f_0 sets an upper limit on the transmission rate that can be used without incorporating an equalizer in the receiver.

Fading Effects Due to Doppler Spread

This type of fading mostly occurs in mobile communication. There are many reasons for this type of fading to occur. The first is that the mobile station or user is likely to be moving, and as a result the path lengths of all the signals being received are changing. The second is that many objects around may also be moving. Automobiles and even

people will cause reflections that will have a significant effect on the received signal [46]. Accordingly multipath fading due to Doppler spread has a major bearing on cellular telecommunications. The time-variant nature or fading rapidity mechanism of the channel can be viewed in terms of two degradation categories as

- Fast fading
- Slow fading

Fast fading

The terminology fast fading is used for describing channels in which channel coherence time, T_0 , is less than time duration of a transmission symbol, T_s . Also, a channel is said to be fast fading if the symbol rate, $1/T_s$ (approximately equal to the signaling rate or bandwidth W) is less than the fading rate, $1/T_0$ (approximately equal to f_d); that is, fast fading is characterized by [4]

$$W < f_d \quad (6.3a)$$

or

$$T_s > T_0 \quad (6.3b)$$

Fast fading referred as condition where the time duration in which the channel behaves in a correlated manner is short as compared with the time duration of a symbol. Therefore, it can be expected that the fading character of the channel will change several times during symbol duration, leading to distortion of the baseband pulse shape. Analogous to the distortion previously described as channel-induced ISI, distortion takes place because the received signal components are not all highly correlated throughout time. Hence, fast fading can cause the baseband pulse to be distorted, often resulting in an irreducible error rate. Such distorted pulses cause synchronization problems (failure of phase-locked loop receivers), in addition to difficulties in adequately designing a matched filter [47].

Slow Fading

A channel is generally referred to as introducing slow fading channel if channel coherence time, T_0 , is greater than time duration of a transmission symbol, T_s . In other words, a channel is referred to as slow fading if the signaling rate is greater than the fading rate. Thus, to avoid signal distortion caused by fast fading, the channel must be

made to exhibit slow fading characteristics by ensuring that the signaling rate exceeds the channel fading rate. That is[4]

$$W > f_d \tag{6.4a}$$

or

$$T_s < T_0 \tag{6.4b}$$

Here, the time duration that the channel behaves in a correlated manner is longer as compared with the time duration of a transmission symbol. Thus, one can expect the channel state to virtually remain unchanged during the time in which a symbol is transmitted or say symbol duration. The propagating symbols likely do not suffer from the pulse distortion described earlier. The primary degradation in a slow-fading channel, as with flat fading, is loss in SNR [46]. Over the years, some authors have confused the terms fast and slow fading with the terms large scale and small scale fading. It should be emphasized that fast and slow fading deal with the relationship between the time rate of change in the channel and the transmitted signal, and not with propagation path loss models.

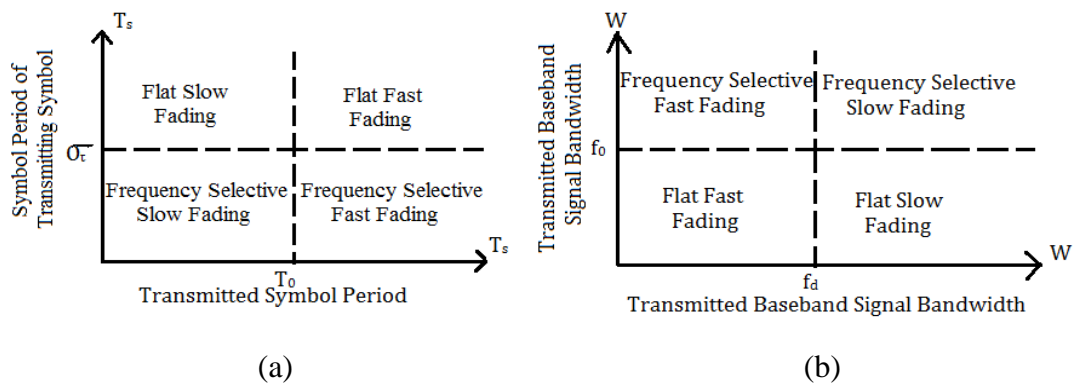

Fig. 6.5: Type of fading experienced by a signal as a function of (a) symbol period (b) baseband signal width [4]

6.3 Channel Models

In a wireless communication channel, the transmitted signal can travel from transmitter to receiver over multiple reflective paths. This gives rise to multipath fading which causes fluctuations in amplitude, phase and angle of arrival of the received signal. For example , the transmitted signal from the BTS (base transceiver station) may suffer multiple reflections from the buildings nearby, before reaching the mobile station.

Such multipath fading channels are often classified into slow fading/fast fading and frequency-selective/flat fading channels. For flat fading, channel is modeled by AWGN, which is typically assumed to be statistically independent of the fading amplitude α , and which is characterized by a one-sided power spectral density N_0 (W/Hz). On the other hand frequency selective channel can be classified as Rayleigh fading channel, Rician fading channel.

6.3.1 Additive white Gaussian noise

AWGN is a channel model in which the only impairment to communication system is a linear addition of wideband or white noise with a constant spectral density (expressed as watts per hertz of bandwidth) and a Gaussian distribution of amplitude. The model does not account for fading, frequency selectivity, nonlinearity, interference or dispersion. However, it produces simple and tractable mathematical models which are useful for gaining insight into the underlying behaviour of a system before these other phenomena are considered. Wideband Gaussian noise comes from many natural sources, such as thermal noise (the thermal vibrations of atoms in conductors) or Johnson Nyquist noise, shot noise, black body radiation from the earth and other warm objects, and from celestial objects such as the Sun [50].

Although AWGN channel model seems very limiting, its study is beneficial from two points of view. First, noise is the major type of corruption introduced by many channels. Therefore isolating it from other channels impairments and studying its effect results in better understanding of its effects on all communication systems. Second, the AWGN channel, although very simple, is a very good model for studying deep space communication channels which were historically one of the first challenges encountered by communication engineers [50].

The AWGN channel is a good model for many satellite and deep space communication links. It is not a good model for most terrestrial links because terrestrial links account for multipath, terrain blocking, interference, etc. However, for terrestrial path modelling, AWGN is commonly used to simulate background noise of the channel under study, in addition to multipath, terrain blocking, interference, ground clutter and self interference that modern radio systems encounter in terrestrial operation.

Basic characteristic of the AWGN channels are

- The noise is additive, i.e., the received signal equals the transmit signal with some noise, where the noise is statistically independent of the signal.
- The noise is white, i.e., the power spectral density is flat, so the autocorrelation of the noise in time domain is zero for any non-zero time offset.
- The noise samples have a Gaussian distribution.

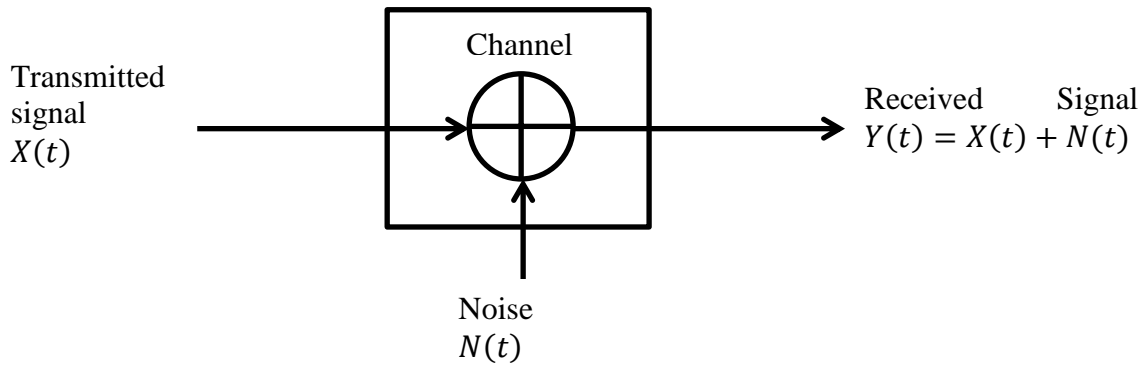

Fig. 6.6: Model for received signal passed through an AWGN channel

AWGN is the commonly used to transmit signal while signals travel from the channel and simulate background noise of channel. Hence, AWGN channel model is given in Fig. 6.6

The mathematical expression in received signal

$$Y(t) = X(t) + N(t) \quad (6.5)$$

is shown in the Fig. 6.4 that passed through the AWGN channel where $X(t)$ is transmitted signal and $N(t)$ is background noise [24]. Where $X(t)$ is the transmitted signal, regarded as a real random process, and $N(t)$ is a real white Gaussian noise process with single-sided noise power density N_0 and also independent of $X(t)$. Moreover, the transmitted signal $X(t)$ is assumed to be both power-limited and band-limited. The average input power of the transmitted signal $X(t)$ is limited to some constant. The channel band is a positive frequency interval with bandwidth W Hz. The channel is said to be baseband if $B = [0, W]$, and passband otherwise. The (positive-frequency) support of the Fourier transform of any sample function $X(t)$ of the input process $X(t)$ is limited to B . The SNR of this channel model is

$$SNR = P/N_0W \quad (6.6)$$

where N_0W is the total noise power in the frequency band B and N_0 is the noise power per positive frequency Hz . Therefore the double-sided power spectral density of $N(t)$ must be $S_{nn}(f) = \frac{N_0}{2}$, at least over the frequency bands $\pm B$.

5.3.1.1 Gaussian Distribution

A Gaussian random variable is one whose probability density function can be written mathematically as

$$f_x(x) = \frac{1}{\sqrt{2\pi\sigma^2}} e^{-\frac{(x-m)^2}{2\sigma^2}}, \quad -\infty < x < \infty \quad (6.7)$$

The PDF of the Gaussian random variable has two parameters, m and σ , which have the interpretation of the mean and standard deviation respectively. The parameter σ^2 is referred to as the variance. In general, the Gaussian PDF is centred about the point $x = m$ and has a width that is proportional to standard deviation, σ . The Cumulative Distribution Function (CDF) is required whenever we want to find the probability that a Gaussian random variable lies above or below some threshold or in some interval. The CDF of a Gaussian random variable is written as.[51]

$$F_x(x) = \int_{-\infty}^x \left(\frac{1}{\sqrt{2\pi\sigma^2}} \right) e^{-(y-m)^2/2\sigma^2} dy \quad (6.8)$$

it can be shown that it is impossible to express this integral in closed form.

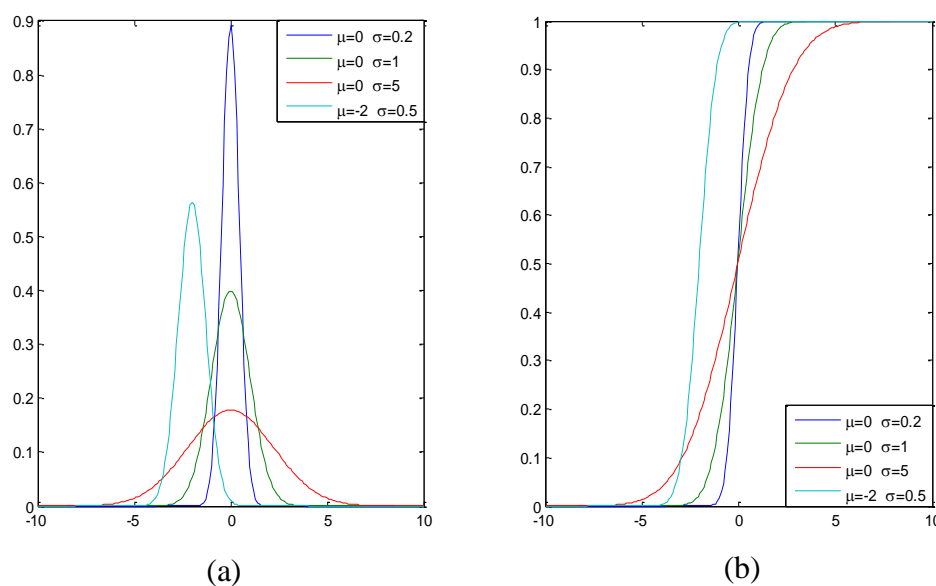

Fig. 6.7: Gaussian distribution (a) PDF (b) CDF

6.3.2 Rayleigh Fading Channel

The delays associated with different signal paths in a multipath fading channel change in an unpredictable manner and can only be characterized statistically. When there are a large number of paths, the central limit theorem can be applied to model the time-variant impulse response of the channel as a complex-valued Gaussian random process. When the impulse response is modeled as a zero-mean complex-valued Gaussian process, the channel is said to be a Rayleigh fading channel [49].

The model behind Rician fading is similar to that for Rayleigh fading, except that in Rician fading a strong dominant component is present. This dominant component can for instance be the line-of-sight wave.

In our case the Rayleigh Fading model is assumed to have only two multipath components $X(t)$ and $Y(t)$. Rayleigh Fading can be obtained from zero-mean complex Gaussian processes ($X(t)$ and $Y(t)$). Simply adding the two Gaussian Random variables and taking the square root (envelope) gives a Rayleigh distributed process. The phase follows uniform distribution.

6.3.2.1 Rayleigh distribution

A Rayleigh random variable has a one sided PDF. The form of the PDF and CDF are given (for any $\sigma > 0$) by

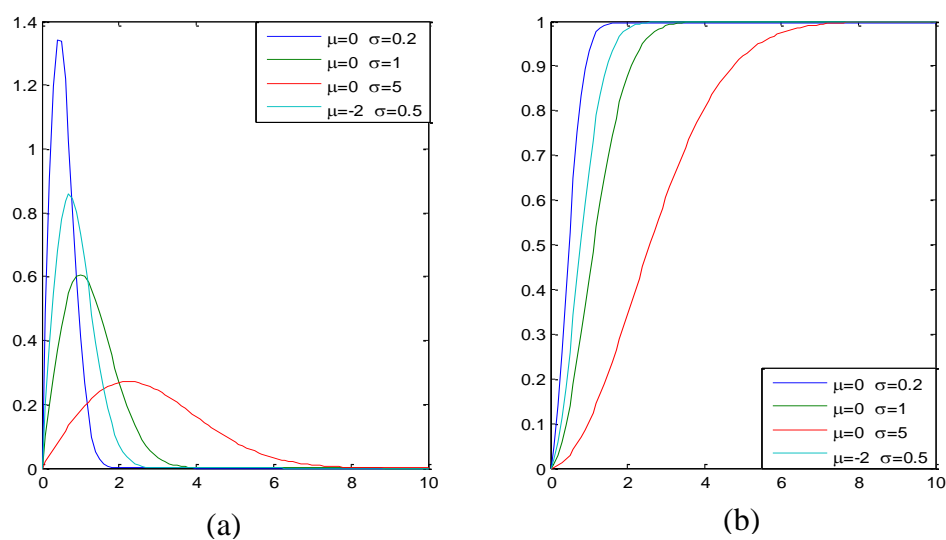

Fig. 6.8: Rayleigh random variable (a) PDF (b) CDF

$$f_x(x) = \left(\frac{x}{\sigma^2}\right) \exp\left(-\frac{x^2}{2\sigma^2}\right) u(x) \quad (6.9a)$$

$$F_x(x) = 1 - \exp\left(-\frac{x^2}{2\sigma^2}\right) \quad (6.9b)$$

6.3.3 Rician Fading Channel

Rician Fading model is used to simulate environments that produce multipath components and also a dominant Line Of Sight (LOS) component. The LOS component is called “specular” component and the multipath component is called “random or scatter” component. The amplitude distribution of the specular component will have non-zero mean, whereas, the random component will have zero-mean. Rician fading channel is a stochastic model for radio propagation anomaly caused by partial cancellation of a radio signal by itself, the signal arrives at the receiver by two different paths (hence exhibiting multipath interference), and at least one of the paths is changing (lengthening or shortening). Rician fading occurs when one of the paths, typically a line of sight signal, is much stronger than the others [49]. In Rician fading, the amplitude gain is characterized by a Rician distribution. In Rician fading, a strong dominant component is present.

6.3.3.1 Rician Distribution

A Rician random variable is closely related to the Rayleigh random variable (in fact, the Rayleigh distribution is a special case of the Rician distribution). The functional form of the PDF for a Rician random variable is given (for any $v > 0$ and any $\sigma > 0$) by [51]

$$f_x(x) = \left(\frac{x}{\sigma^2}\right) \exp\left(-x^2 + \frac{v^2}{2\sigma^2}\right) I_0\left(\frac{vx}{\sigma^2}\right) u(x) \quad (6.10)$$

in this expression, the function $I_0(x)$ is the modified Bessel function of the first kind

of order zero, which is defined by

$$I_0(x) = \frac{1}{2\pi} \int_0^{2\pi} e^{x \cos \theta} d\theta \quad (6.11)$$

like the Gaussian random variable, the CDF of a Rician random variable cannot be written in closed form [52]. The following figure shows the PDF and CDF of Rician distribution.

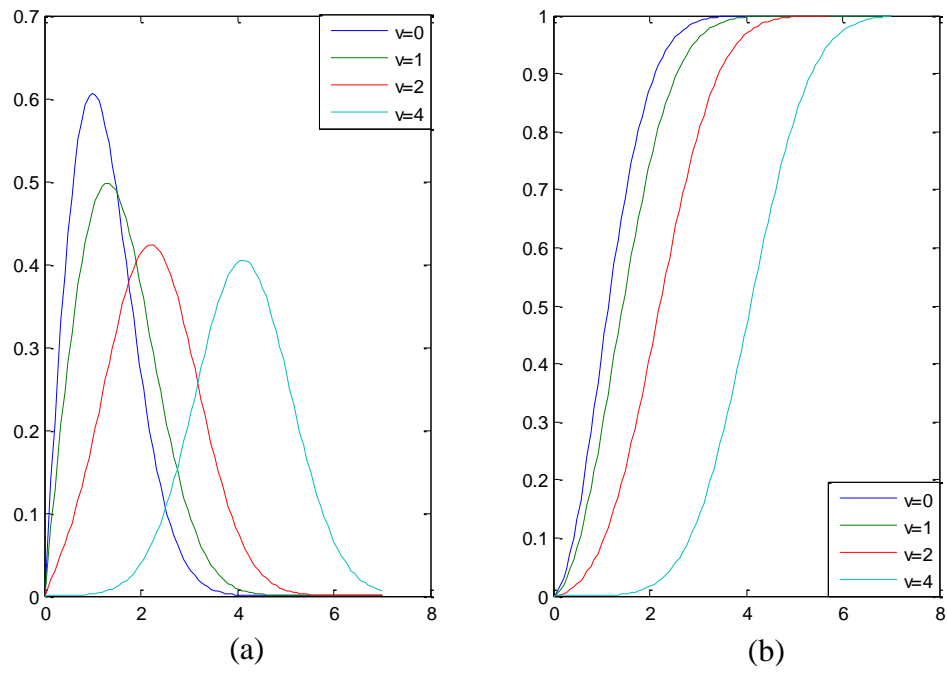

Fig. 6.9 Rician random variable (a) PDF and (b) CDF for $\sigma = 1$

CHAPTER 7

RESULT AND DISCUSSION

One of the main changes that modern digital communication systems have brought to radio engineering is the need for end-to-end performance measurements. The measure of that performance is usually BER, which quantifies the reliability of the entire radio system. The BER is the number of bit errors divided by the total number of transferred bits during a studied time interval. BER is a unitless performance measure, often given by

$$BER = \frac{\text{Errors}}{\text{total number of bits}} \quad (7.1)$$

With a strong signal and noiseless channel, this number is so small that it is insignificant. It becomes significant when we wish to maintain a sufficient SNR in the presence of imperfect transmission through electronic circuitry (amplifiers, filters, mixers, and digital/analog converters) and the propagation medium (e.g. the radio path).

SNR is a measure used in science and engineering to quantify how much a signal has been corrupted by noise. It is defined as the ratio of signal power to the noise power corrupting the signal. In general, SNR compares the level of a desired signal to the level of background noise. The higher the ratio, the less obtrusive the background noise is and more is the signal strength. SNR is sometimes used informally to refer to the ratio of useful information to false or irrelevant data in a conversation or exchange.

Noise is the main enemy of BER performance. Noise is a random process, defined in terms of statistics. The noise introduced by the circuitry is described with a Gaussian probability density function, while the channel noise is usually described with a Rayleigh, Rician probability density function.

This chapter is divided into two sections. The first section calculates BER for different values of SNR for different modulation schemes. The second section deals with PAPR analysis for different modulation schemes and its reduction with SLM.

The system model was implemented in MATLAB for MPSK, GMSK, $\pi/4$ -DQPSK modulation schemes. BER performance analysis is done by taking random data stream of defined length for different modulation schemes. Here data is transmitted by using OFDM technique in which large numbers of closely-spaced orthogonal sub-carriers are

used to carry data. Each sub-carrier is modulated with a above given digital modulation schemes. Various fading channels are used to the encoded data passed through it. In AWGN channel SNR (dB) denotes the signal to noise ratio. The simulation is performed between SNR and BER. The GMSK and $\pi/4$ -DQPSK modulation has been chosen and results have been compared with 16PSK and 64PSK modulation schemes which are obtained by Fuquin Xiong in 2003 [13].

In the system, the following specifications are used for the system simulation:

- Parameters of the simulation: 52 carriers, FFT/IFFT size is 64, and cyclic prefix 12.
- Four types of modulation schemes: 16PSK, 64PSK, $\pi/4$ -DQPSK, GMSK used in simulations.
- There are three types of channel models AWGN, Rayleigh fading, Rician fading used in simulations.
- The three different outputs of the simulation are: BER vs SNR, PAPR, reduction of PAPR with SLM scheme.

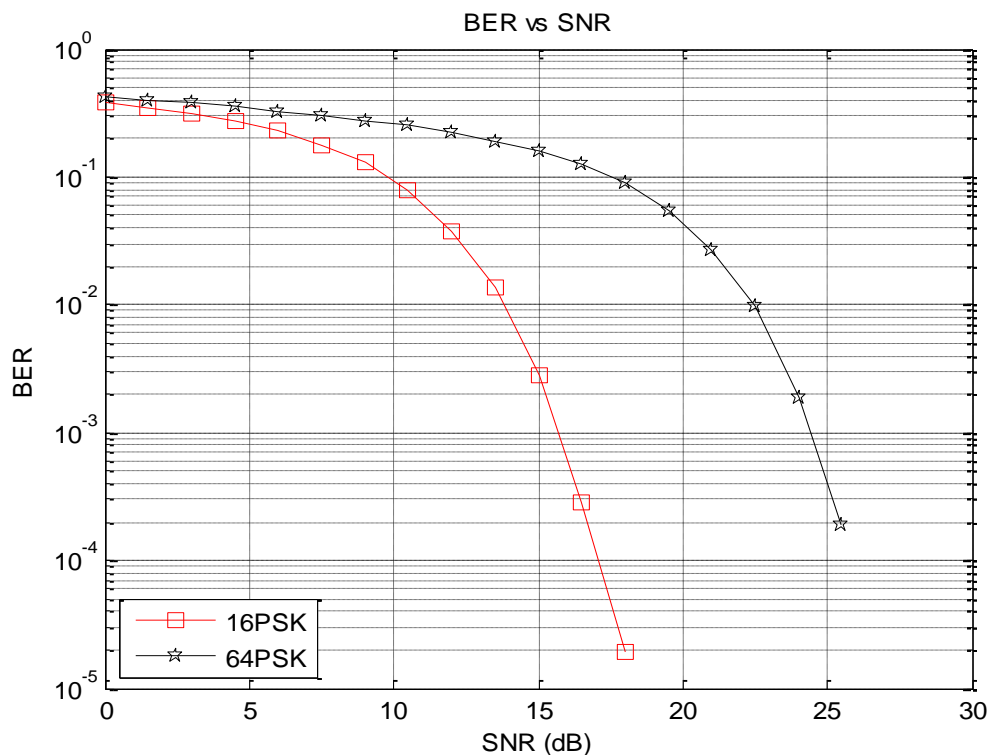

Fig. 7.1: BER performance of 16PSK and 64PSK over AWGN channel

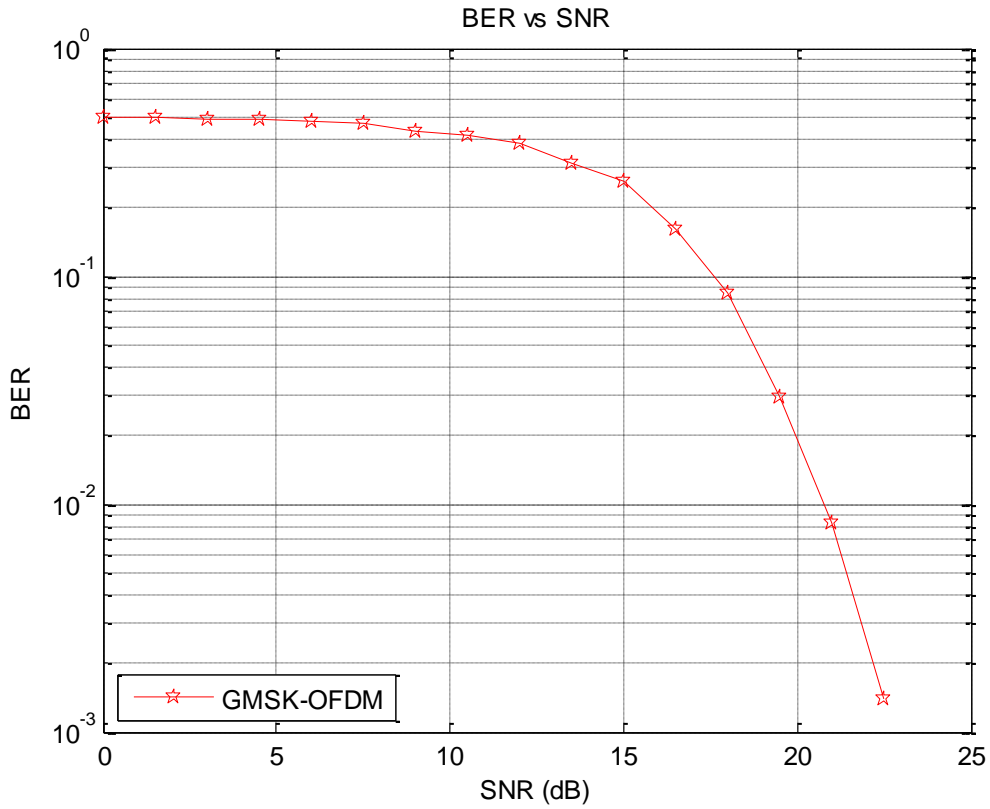

Fig. 7.2: BER performance of GMSK-OFDM over AWGN channel

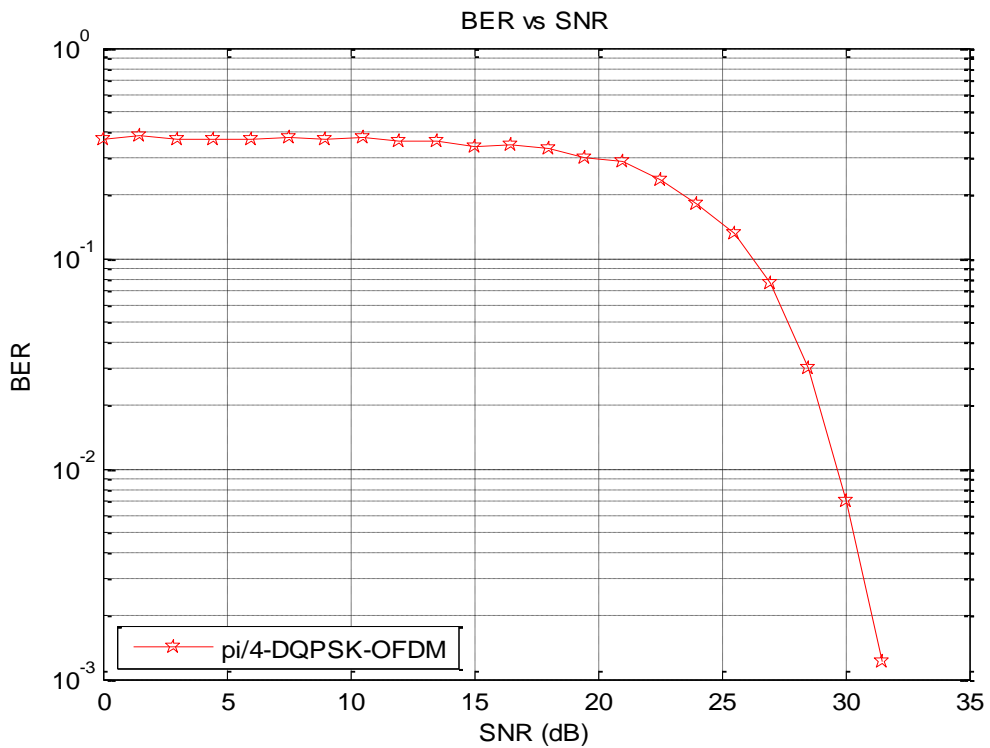

Fig. 7.3: BER performance of $\pi/4$ –DQPSK over AWGN channel

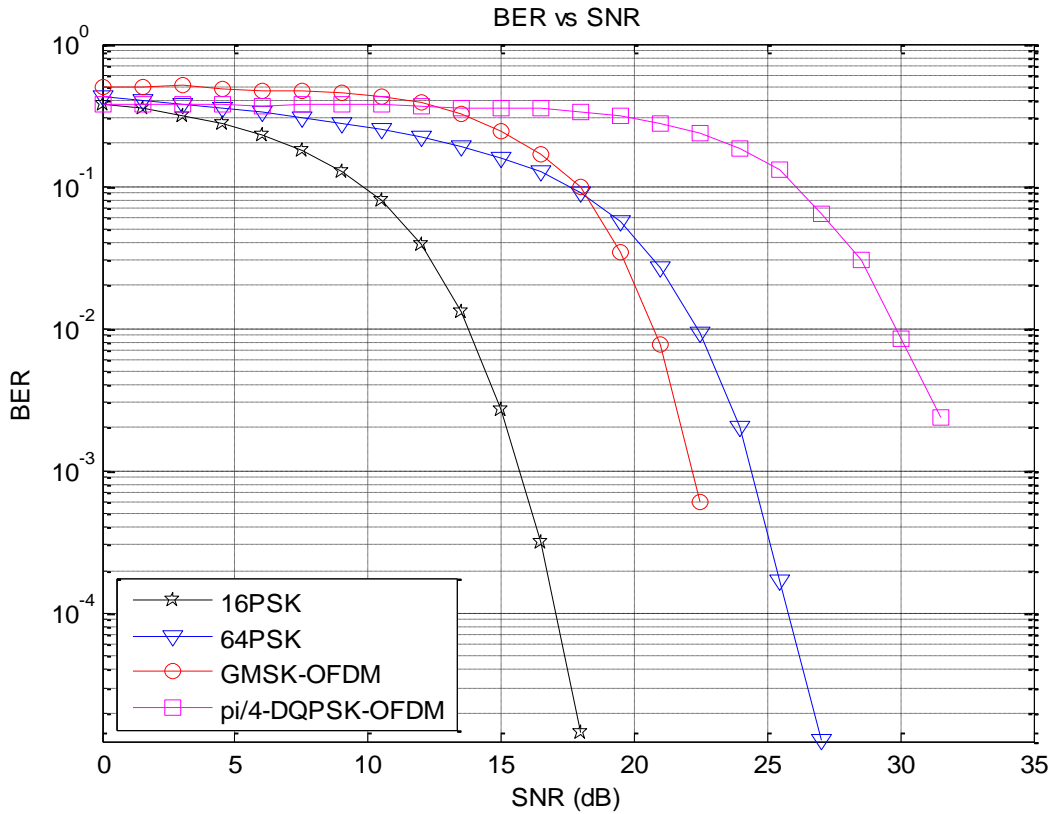

Fig. 7.4: BER performance for different modulation schemes over AWGN channel

BER performance of an OFDM System with 16PSK, 64PSK, $\pi/4$ -DQPSK, GMSK is plotted against SNR over AWGN channel (Fig. 7.4), the obtained BER values for 16PSK and 64PSK are exactly same as obtained by Fuquin Xiong in 2003 [53], these result are compared with GMSK and $\pi/4$ -DQPSK. The observed value of BER is 10^{-3} (approx.) for SNR values of 16 for 16PSK, 22 for GMSK, 24 for 64PSK and 32 for $\pi/4$ -DQPSK. The BER performance of GMSK and 64PSK are quite similar.

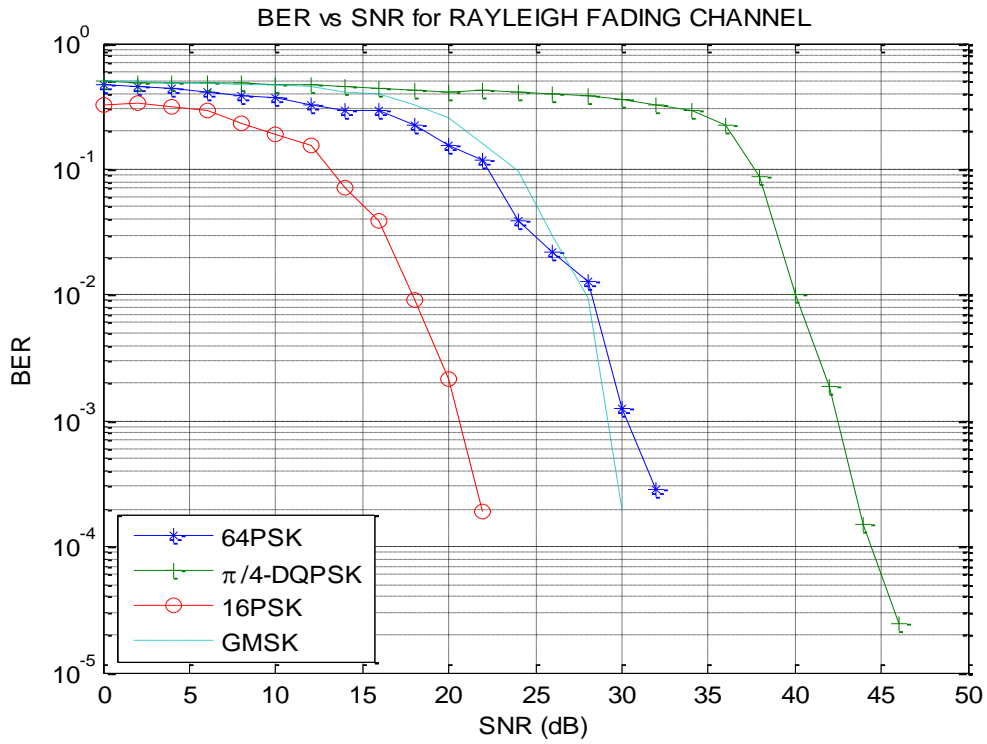

Fig. 7.5: BER performance for different modulation schemes over Rayleigh fading channel

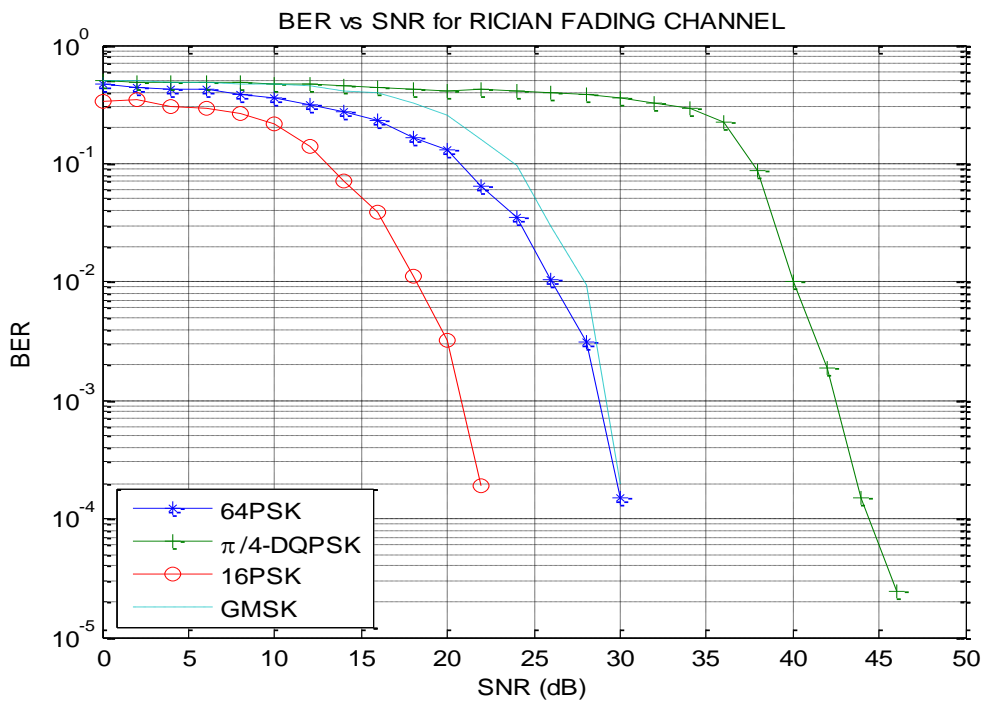

Fig. 7.6: BER performance for different modulation schemes over Rician fading channel

BER performance of an OFDM System with 16PSK, 64PSK, $\pi/4$ –DQPSK, GMSK is plotted against SNR over Rayleigh fading channel, Rician fading channel. $\pi/4$ –DQPSK shows better result than all other modulations used in the system

PAPR Analysis and Reduction Using SLM Technique

The mapping schemes used for simulation is 16PSK, 64PSK, $\pi/4$ –DQPSK, GMSK. It is OFDM system, so it has to deal with PAPR problem. The simulation for PAPR has been carried out using 10000 symbols. CCDF and histogram plot are plotted for all mapping schemes. SLM PAPR reduction scheme is used here. This approach is applicable with all types of modulation and any number of subcarriers. The amount of PAPR reduction using SLM depends on the number of phase sequences U and the design of the phase sequences.

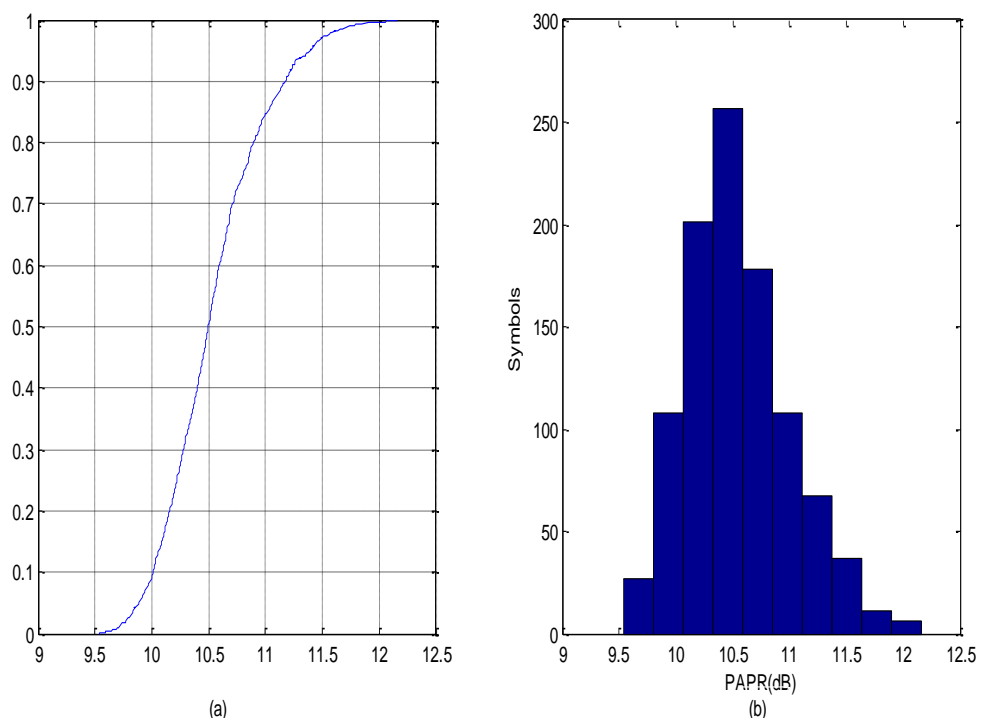

Fig. 7.7: PAPR for 16PSK (a) CCDF Function (b) Histogram

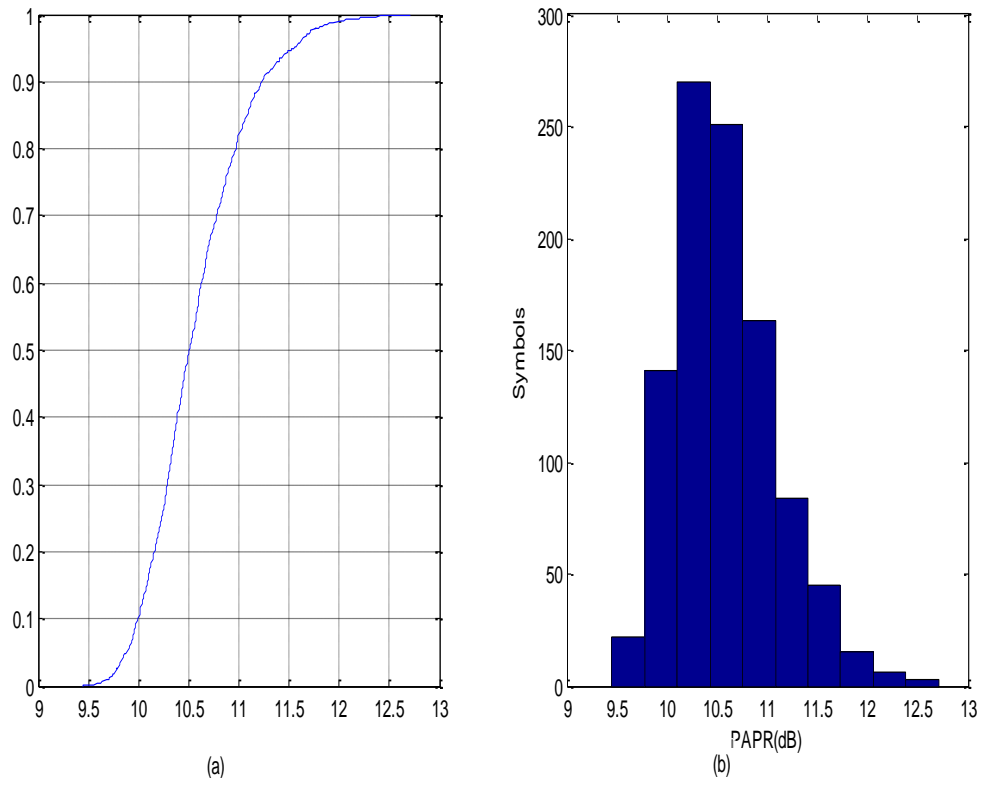

Fig. 7.8: PAPR for 64PSK (a) CCDF Function (b) Histogram

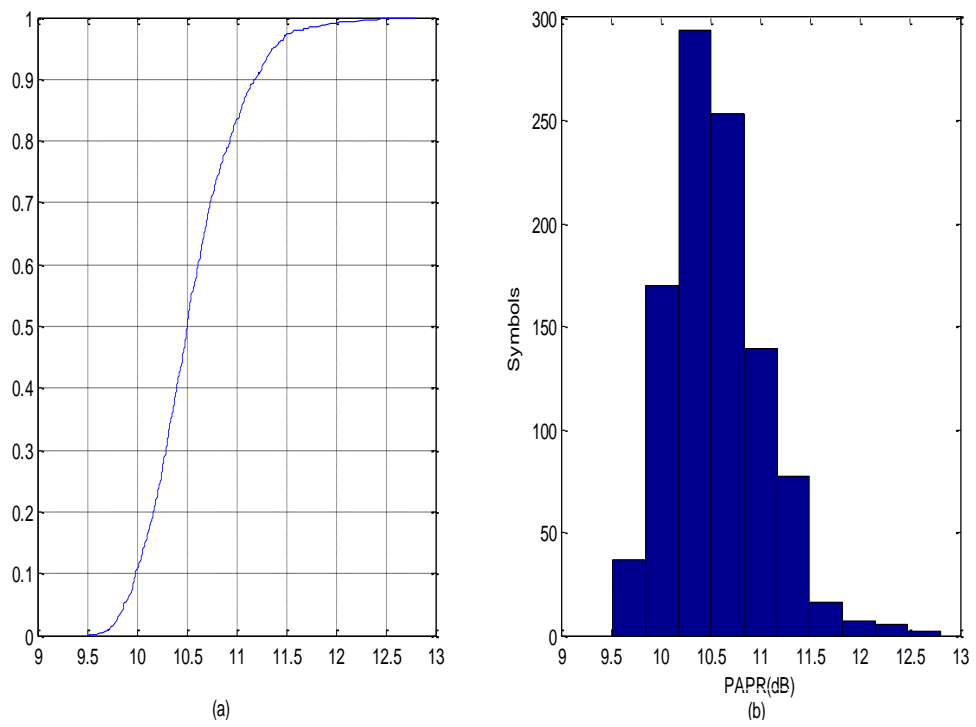

Fig. 7.9: PAPR for $\pi/4$ -DQPSK (a) CCDF Function (b) Histogram

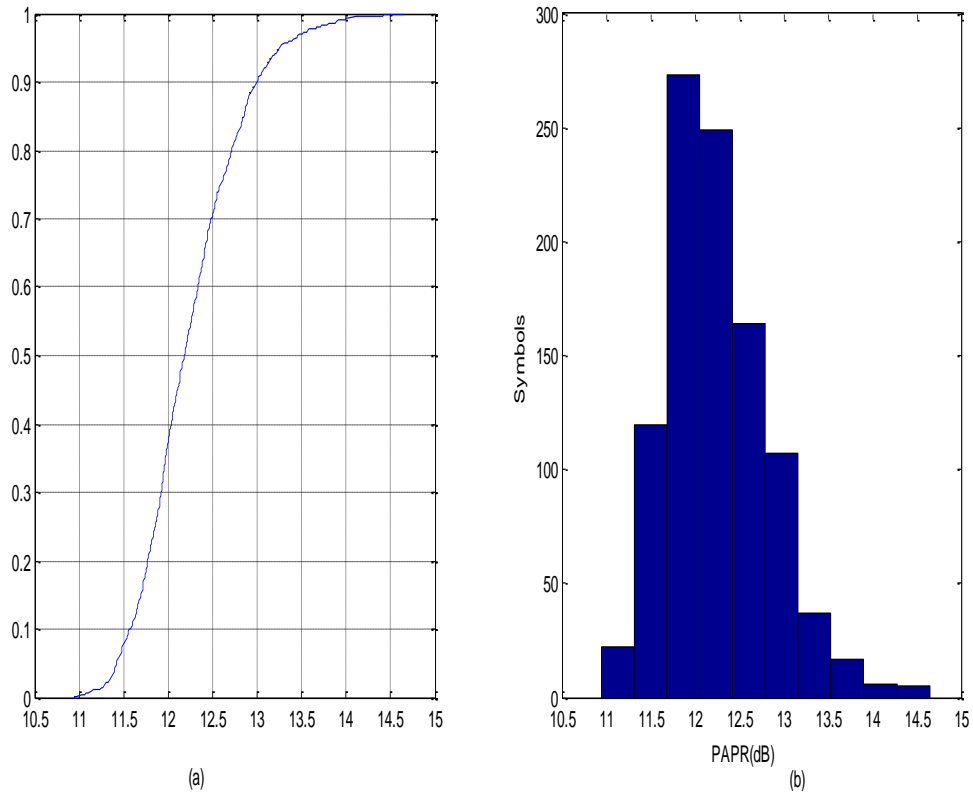

Fig. 7.10: PAPR for GMSK (a) CCDF Function (b) Histogram

The OFDM system is simulated using modulation schemes described in chapter 4. PAPR is calculated and CCDF and histogram plots are plotted for all the mapping schemes fig. 7.5-7.8. to show PAPR graphically. The obtained values of PAPR for all modulations along with elapsed time are shown in the table.

Table 7.2: Values of PAPR and elapsed time for Different Modulation Scheme

Modulation Scheme used	PAPR(dB)	Elapsed time(sec)
16PSK	12.16	12.95
64PSK	12.71	14.63
$\pi/4$ -DQPSK	12.80	18.78
GMSK	14.64	17.43

The above table depicts that PAPR is highest for OFDM system based on GMSK modulation scheme.

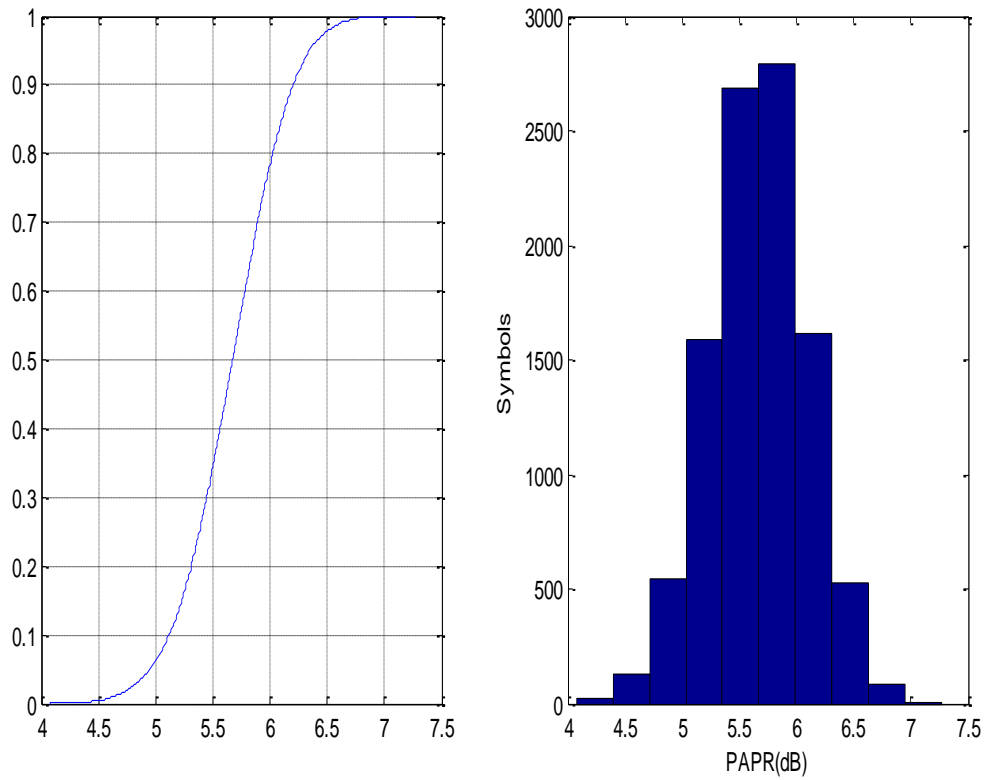

Fig. 7.11: PAPR for 16PSK after applying SLM with U=10 (a) CCDF (b) Histogram

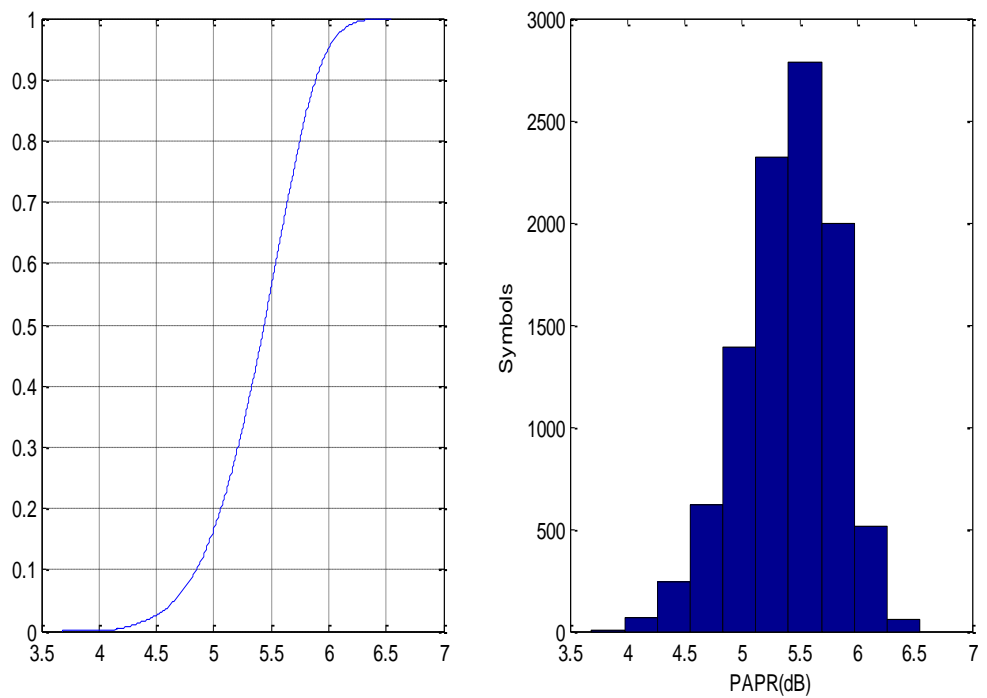

Fig. 7.12: PAPR for 16PSK after applying SLM with U=20 (a) CCDF (b) Histogram

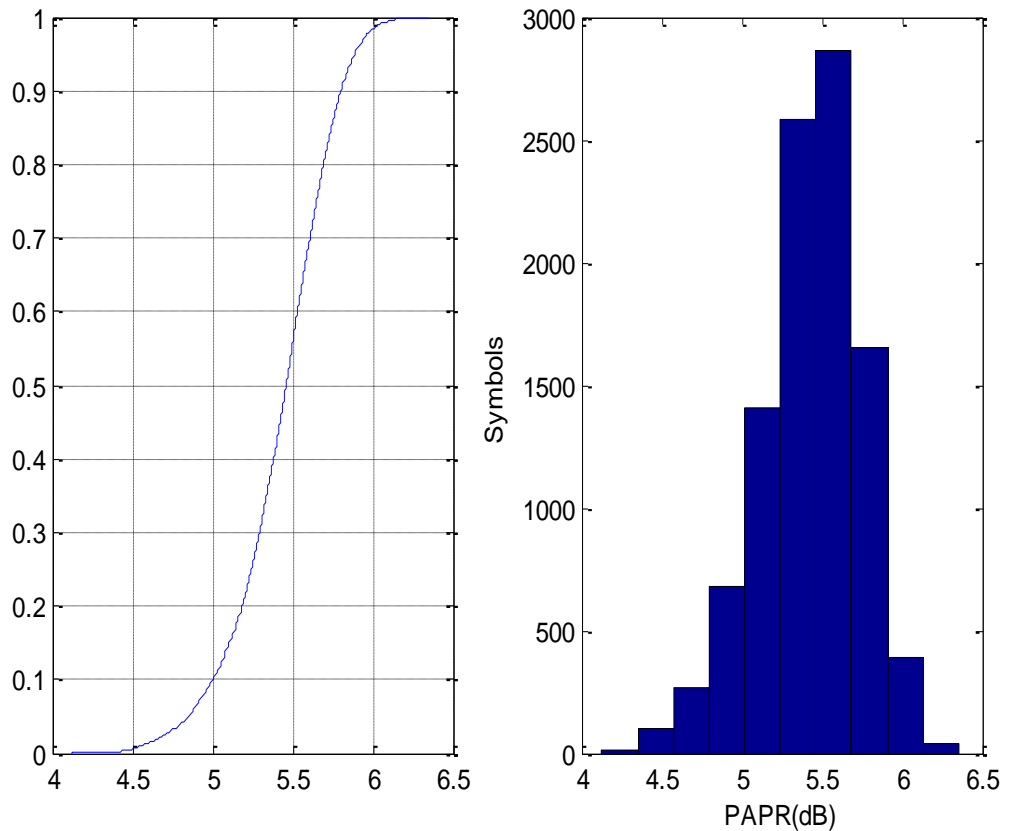

Fig. 7.13: PAPR for 16PSK after applying SLM with $U=30$ (a) CCDF (b) Histogram

Table 7.2: Summary of reduced PAPR and elapsed time for 16PSK

Number of Phase Sequence (U)	PAPR (dB)	Reduction in PAPR (dB)	Elapsed Time (sec)
10	7.265	4.895	23.50
20	6.601	5.559	32.06
30	6.290	5.870	57.75

The SLM technique for an OFDM system for 16PSK with 64 subcarriers is implemented . The number of phases chosen for simulation are $U = 10, 20, 30$. The table 7.1 depicts that as number of phase sequences increases the value of PAPR decreases for 16PSK but the cost is paid in the form of computational complexity and system latency. Here maximum 5.87dB reduction in PAPR is obtained with $U = 30$.

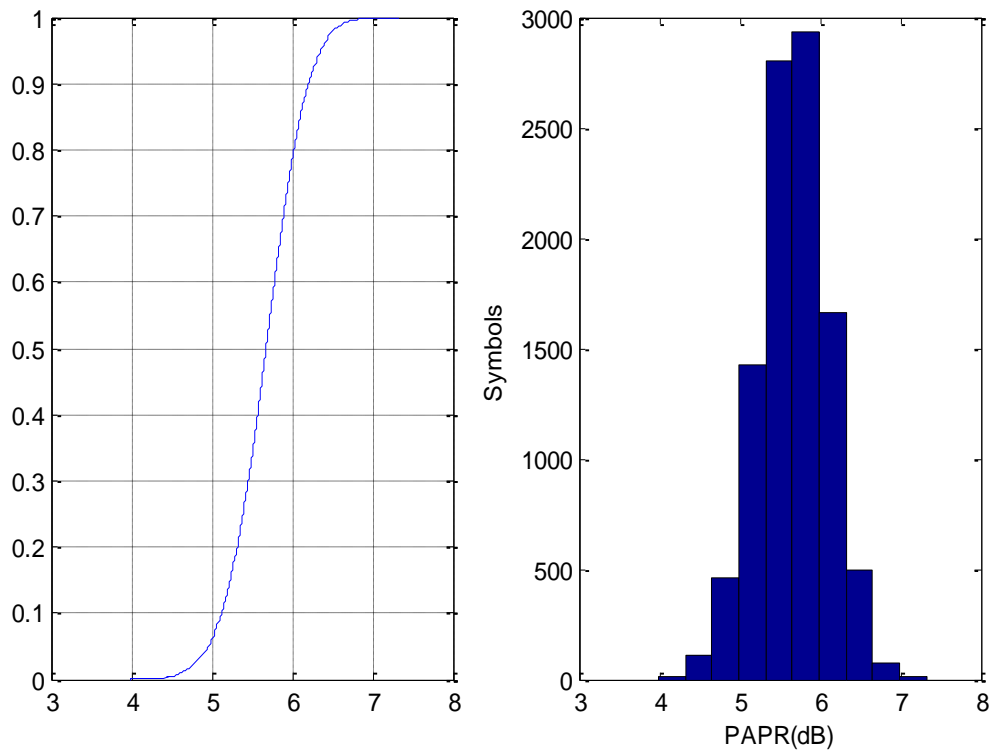

Fig. 7.14: PAPR for 64PSK after applying SLM with U=10 (a) CCDF (b) Histogram

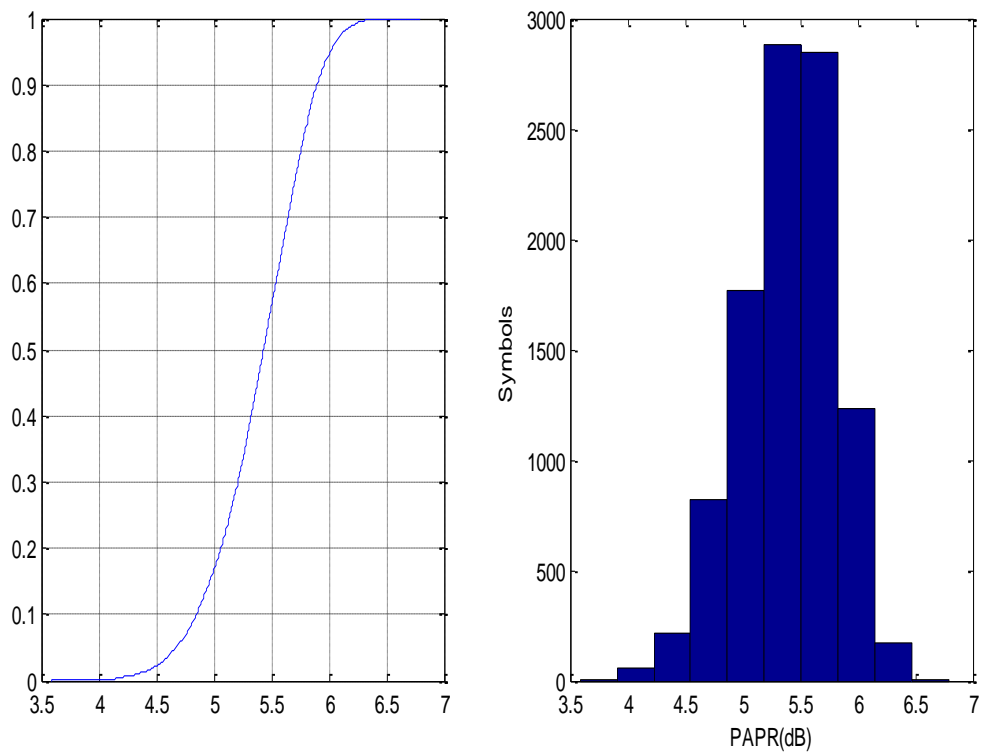

Fig. 7.15: PAPR for 64PSK after applying SLM with U=20 (a) CCDF (b) Histogram

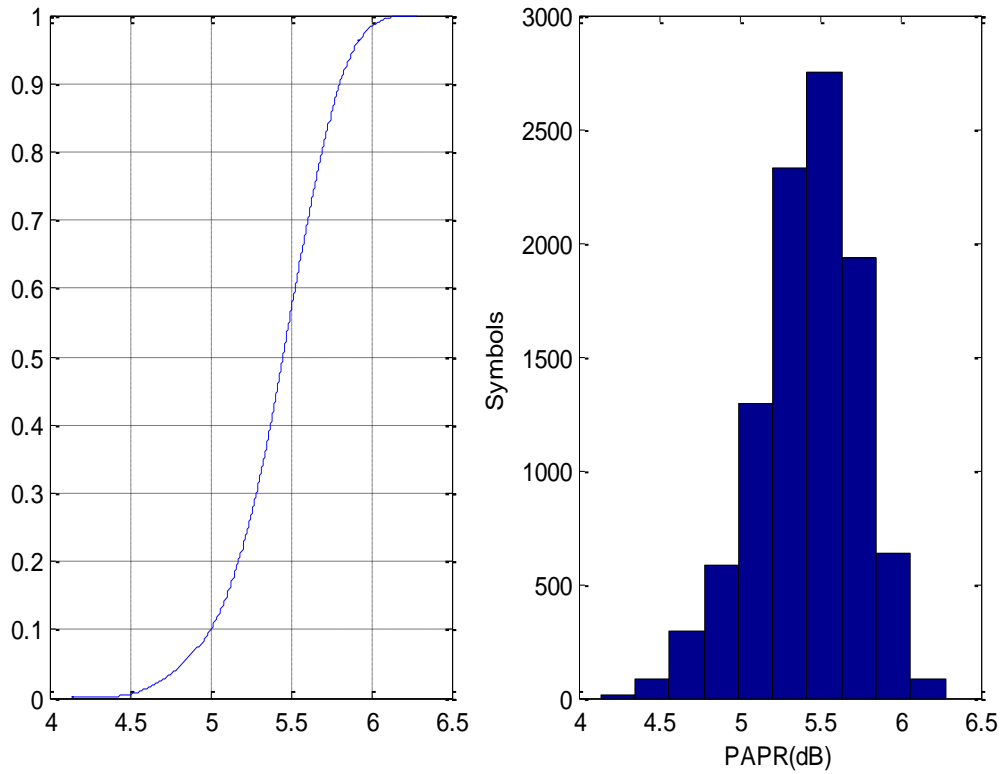

Fig. 7.16: PAPR for 64PSK after applying SLM with U=30 (a) CCDF (b) Histogram

Table 7.3: Summary of reduced PAPR and elapsed time for 64PSK

Number of Phase Sequence (U)	PAPR (dB)	Reduction in PAPR (dB)	Elapsed Time (sec)
10	7.320	5.390	16.92
20	6.792	5.918	31.34
30	6.272	6.438	56.22

The SLM PAPR reduction technique for an OFDM system with 64PSK using 64 subcarriers is implemented. The number of phases chosen for simulation is $U = 10, 20, 30$. The table 7.2 depicts that as number of phase sequences increases, the value of PAPR decreases for 64PSK but the cost is paid in the form of computational complexity and system latency. Here maximum 6.438dB reduction in PAPR is obtained with $U = 30$.

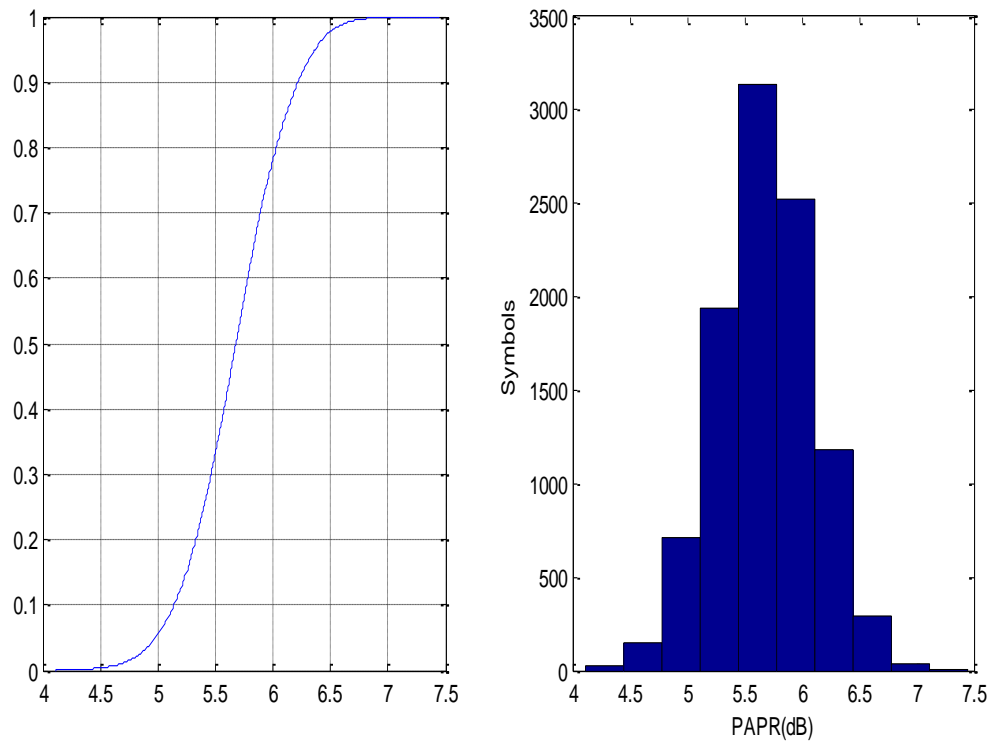

Fig. 7.17: PAPR for $\pi/4$ -DQPSK after applying SLM with $U=10$ (a) CCDF (b) Histogram

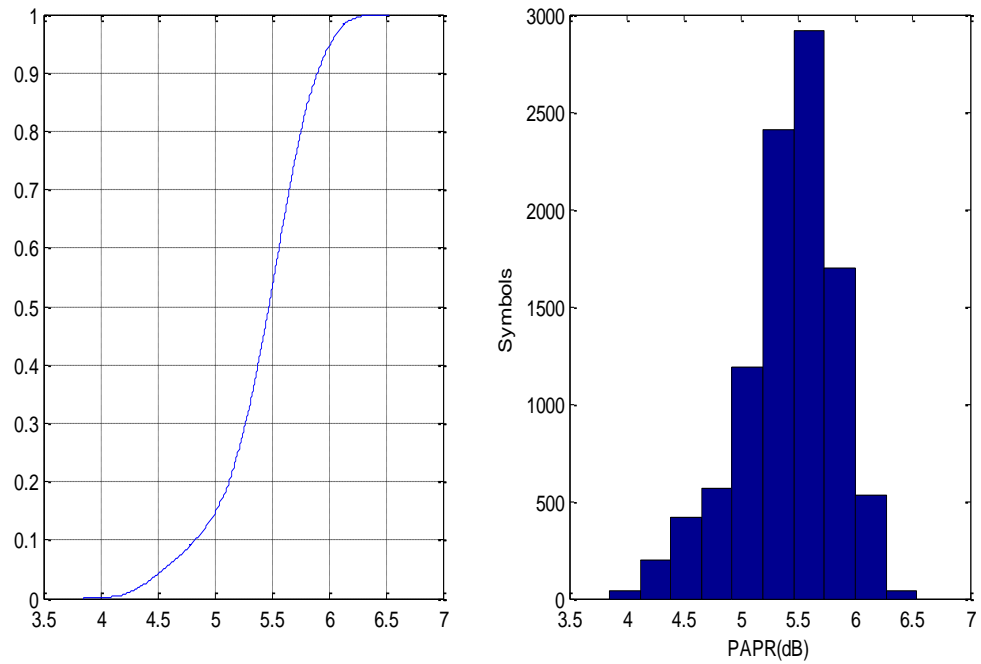

Fig. 7.18: PAPR for $\pi/4$ -DQPSK after applying SLM with $U=20$ (a) CCDF (b) Histogram

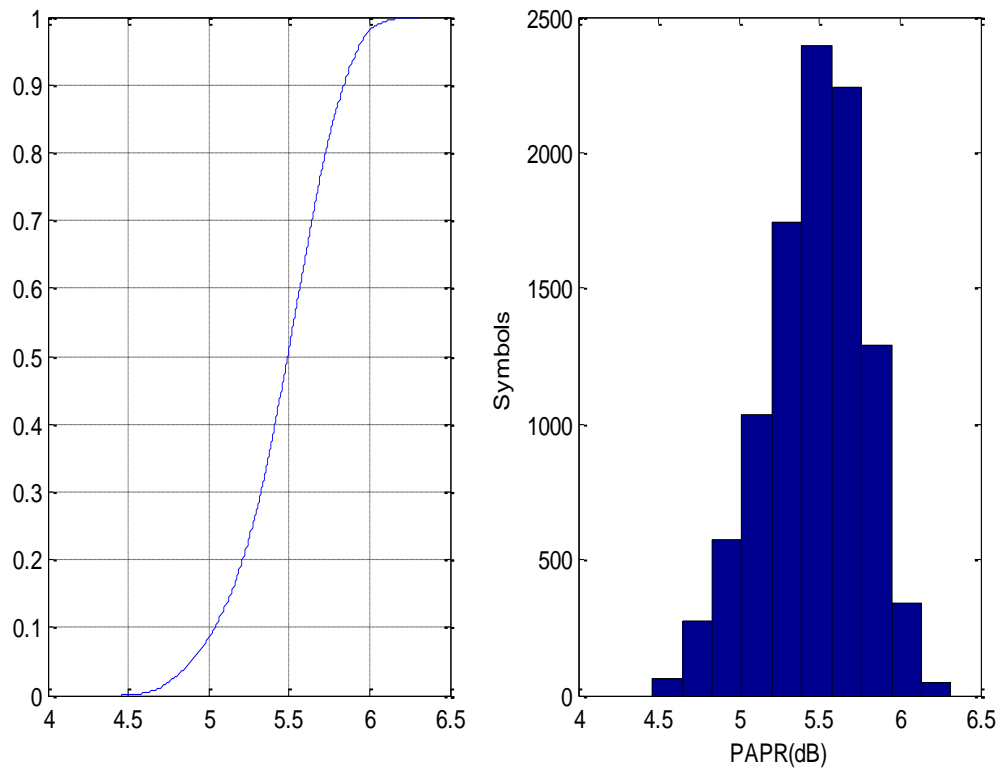

Fig. 7.19: PAPR for $\pi/4$ –DQPSK after applying SLM with $U=30$ (a) CCDF (b) Histogram

Table 7.4: Summary of reduced PAPR and elapsed time for $\pi/4$ –DQPSK

Number of Phase Sequence (U)	PAPR (dB)	Reduction in PAPR (dB)	Elapsed Time (sec)
10	7.446	5.354	21.93
20	6.533	6.267	48.24
30	6.317	6.483	57.21

The SLM technique for an OFDM system with $\pi/4$ –DQPSK using 64 subcarriers is implemented. The number of phases chosen for simulation is $U = 10, 20, 30$. The table 7.3 depicts that as number of phase sequences increases, the value of PAPR decreases for 64PSK but the cost is paid in the form of computational complexity and system latency. Here maximum 6.438dB reduction in PAPR is obtained with $U = 30$.

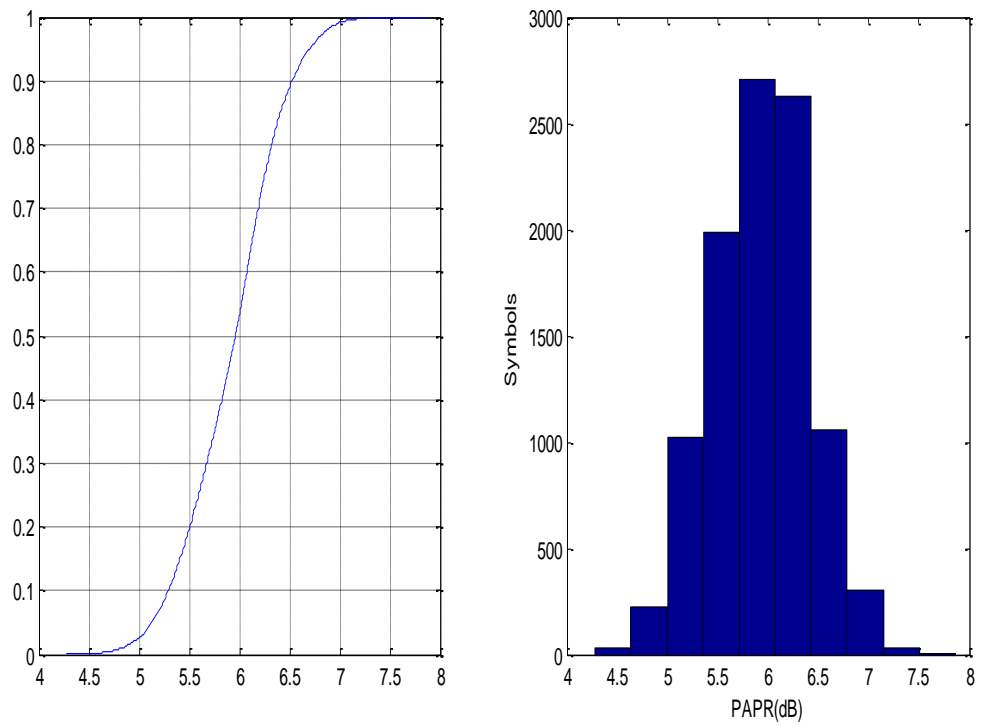

Fig. 7.20: PAPR for GMSK after applying SLM with U=10 (a)CCDF (b) Histogram

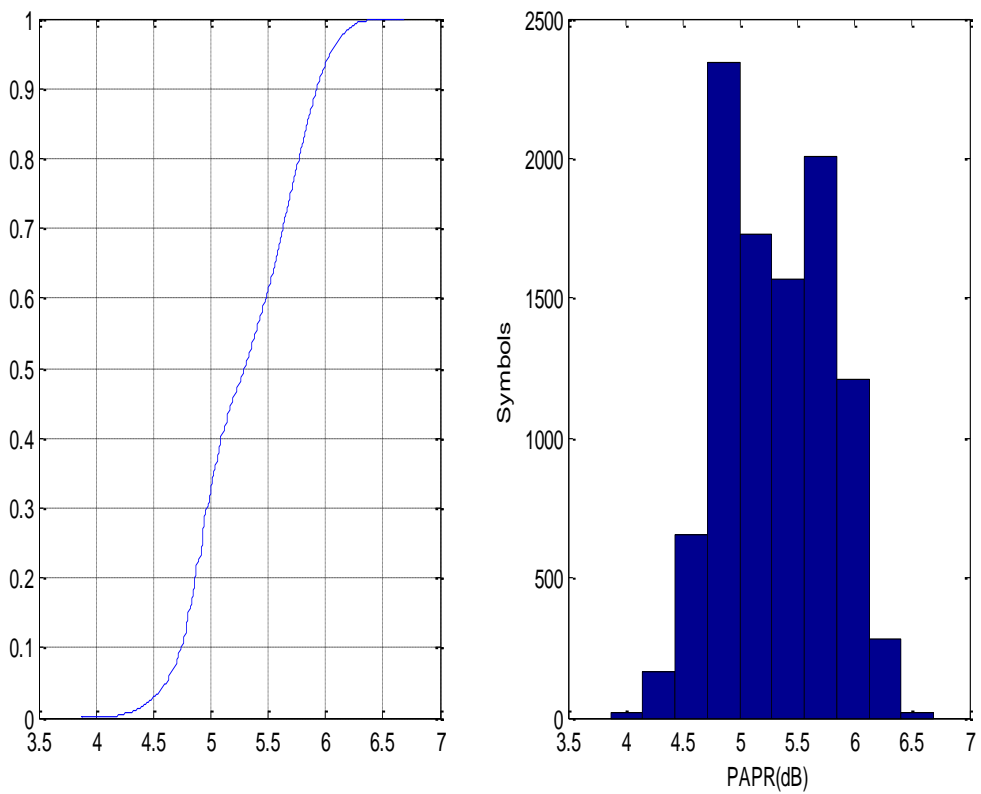

Fig. 7.21: PAPR for GMSK after applying SLM with U=20 (a) CCDF (b) Histogram

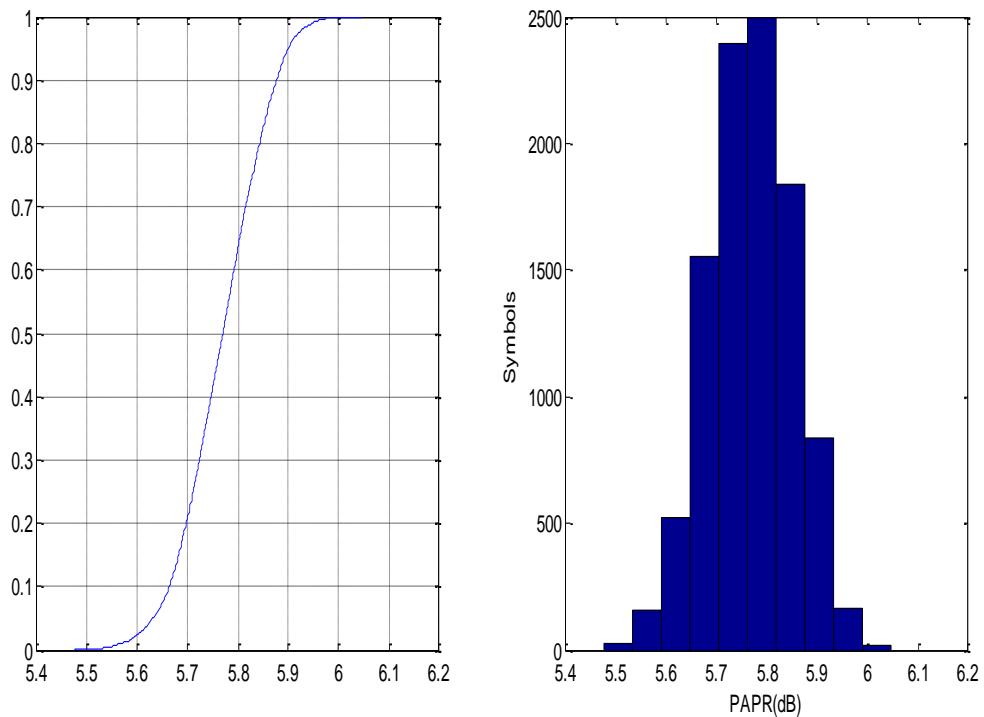

Fig. 7.22: PAPR for GMSK after applying SLM with U=30 (a) CCDF (b) Histogram

About 8.5 dB PAPR has been reduced by using 30 different phase sequences

Table 7.5: Summary of reduced PAPR and elapsed time for GMSK

Number of Phase Sequence (U)	PAPR (dB)	Reduction in PAPR (dB)	Elapsed Time (sec)
10	7.863	6.777	18.57
20	6.687	7.953	34.25
30	6.047	8.593	47.46

The SLM technique for an OFDM system with GMSK using 64 subcarriers is implemented. The number of phases chosen for simulation is $U = 10, 20, 30$. The table 7.4 depicts that as the number of phase sequences increases, the value of PAPR decreases for 64PSK but the cost is paid in the form of computational complexity and system latency. Here maximum 8.593dB reduction in PAPR is obtained with $U = 30$.

8.1 CONCLUSION

In this dissertation, performance of the OFDM systems with digital modulation schemes, such as, MPSK, $\pi/4$ -DQPSK, and GMSK is presented. Performance of OFDM system with these modulation schemes is analyzed under AWGN, Rayleigh fading and Rician fading channel. OFDM system can be implemented using higher order modulations to achieve large data capacity. As the order of modulation increases the BER also increases. Because on increasing the order of modulation, the decision regions for the demodulator in the constellation diagram decreases and this result in a high probability of error. At lower values of SNR the channel will distort the signal more severely. These distortions lead to shifting of the constellation points of the signal and hence, cause the demodulator to produce degraded signal. It is observed that BER will decrease, as the value of SNR is increased because the effect of distortion introduced by the channel will also goes on decreasing. Hence, large data capacity can be achieved over the existing channels by increasing the value of SNR, keeping in mind the extent to which it can be increased. In this dissertation, OFDM system with GMSK, $\pi/4$ -DQPSK modulation scheme is implemented. As GMSK is CPM, which can gives higher bandwidth efficiency than QPSK and higher-order MPSK. And $\pi/4$ -DQPSK gives much smaller fluctuations of the envelope than that of QPSK. BER performance analysis is done for GMSK, $\pi/4$ -DQPSK modulated OFDM system and results are compared with 16PSK and 64PSK. The observed value of BER is 10^{-3} (approx.) for SNR values of 16 for 16PSK, 22 for GMSK, 24 for 64PSK and 32 for $\pi/4$ -DQPSK. The BER performance of GMSK and 64PSK are quite similar.

In this dissertation, an overview of PAPR for OFDM with above described modulation schemes is also given. It has been observed that PAPR remains above 12 dB for all modulation schemes which are used in the simulation. As PAPR is the major drawback of OFDM system, it is reduced using SLM technique. Using SLM technique with 30 phase sequences for $\pi/4$ -DQPSK-OFDM system using 64 subcarriers 6.483dB reduction in PAPR is observed. SLM technique with GMSK-OFDM system can reduce PAPR upto 8.593dB with 30 phase sequences.

8.2 FUTURE WORK

Further this work can be extended to increase the performance of the OFDM system by using channel encoder and convolutional encoder. Also OFDM system with digital modulation schemes, such as $\pi/4$ -DQPSK, GMSK can be extended to MIMO-OFDM.

REFERENCES

- [1] H. Harada and R. Prasad, *Simulation & Software Radio for Mobile Communications*, London: Artech house Publisher, 2002.
- [2] V. N. Richard and R. Prasad, *OFDM for Wireless Multimedia Communication*, London: Artech house Publisher, 2000.
- [3] 1G: First Generation wireless technology [Online], Available: <http://en.wikipedia.org/wiki/1G> [Accessed: Jan. 2013]
- [4] T. S. Rappaport, *Wireless Communications-Principles and Practice*, 2nd ed., New Jersey: Prentice-Hall publications, 2002.
- [5] L. J. Cimini, "Analysis and simulation of a digital mobile channel using orthogonal frequency division multiplexing," *IEEE Trans. on Commun.*, vol. 33, Issue 7, pp. 665–675, July 1985.
- [6] IEEE 802.11a-1999, *Part 11: Wireless LAN Medium Access Control (MAC) and Physical Layer (PHY) Specifications: High-Speed Physical Layer in the 5 GHz Band*, IEEE, Aug. 1999.
- [7] IEEE 802.16-2004, *IEEE Standard for Local and Metropolitan Area Networks Part16: Air Interface for Fixed Broadband Wireless Access Systems*, IEEE, Oct. 2004.
- [8] T. May, H. Rohling, "Reducing The Peak to average Power Ratio on OFDM," *IEEE Veh Technol. Conf. on Radio Transmission Syst.*, vol. 3, pp. 2474-2478, May 1988
- [9] R. Bauml, R. F. H. Fischer, J. B. Huber, "Reducing the Peak to Average Power Rat of Multicarrier Modulation by Selective Mapping," *IEEE Electronics Lett*, vol. 32, no. 22, Oct. 1996.
- [10] T. A. Wilkison and A. E. Jones, "Minimization of the Peak to mean Envelope Power Ratio of Multicarrier Transmission Schemes by Block Coding," *IEEE Veh. Conf.*, vol. 2, Jul. 1995.
- [11] A. Hyo-Joo, S. Yoan, I. Sungbin, "A Block Coding Scheme for Peak to Average Power Ratio Reduction in an Orthogonal Frequency Division Multiplexing System," in *Proc. IEEE Veh. Conf.*, vol. 1, May 2000.
- [12] Y. Zhang, A. Yongacoglu, J. Y. Chouinard, L. Zhang, "OFDM Peak Power Reduction By Sub-Block-Coding And Its Extended Versions," *IEEE Veh. Tech. Conf.*, vol.1, pp. 695 – 699, Jul. 1999.

- [13] D. Wulich, "Reduction of peak to mean ratio of multicarrier modulation using cyclic coding," *IEEE Electronics Lett.*, vol. 32, no. 5, pp. 432-433, Feb. 1996.
- [14] S. Y. Le Goff, S. S. Al-Samahi, B. K. Khoo, C. C. Tsimenidis, B. S. Sharif, "Selected Mapping without Side Information for PAPR Reduction in OFDM," *IEEE Trans. on Wireless Commun.*, vol. 8, no. 7, July 2009.
- [15] K. D. Choe, S. C. Kim, S. K. Park, "Pre-Scrambling Method for PAPR Reduction in OFDM Communication Systems," *IEEE Trans. on Consumer Electronics*, vol. 50, no. 4, Nov. 2004.
- [16] S. H. Muller, J. B. Huber, "OFDM with Reduced Peak to Average Power Ratio by optimum combination of Partial Transmit Sequences," *IEEE Electronics Lett.*, vol.33, issue 5, Feb. 1997.
- [17] C. L. Wang, S. J. Ku, C. J. Yang, "A Low-Complexity PAPR Estimation Scheme for OFDM Signals and Its Application to SLM-Based PAPR Reduction," *IEEE J. of Selected Topics In Signal Processing*, vol. 4, issue 3, pp. 637-645, June 2010.
- [18] Y. Zhou, T. Jiang, "A Novel Multi-Points Square Mapping Combined With PTS to Reduce PAPR of OFDM Signals Without Side Information," *IEEE Trans. on Broadcast.*, vol. 55, no. 4, pp. 831-835, Dec. 2009.
- [19] X. Wu, J. Wang, Z. Mao, J. Zhang, "Conjugate Interleaved Partitioning PTS Scheme for PAPR Reduction of OFDM Signals," *Circuits, Systems and Signal Processing*, vol. 29, no. 3, pp. 499-514, June 2010.
- [20] B. M. Kang, H. G. Ryu, S. B. Ryu, "A PAPR Reduction Method using New ACE (Active Constellation Extension) with Higher Level Constellation," *IEEE International Conf. on Signal Processing and Communications*, pp. 724-727, Nov. 2007.
- [21] A. D. S. Jayalath, C. Tellambura, "The use of Interleaving to Reduce the Peak to Average Power Ratio of an OFDM Signals," *IEEE Global telecommun conf.*, vol. 1, Nov. 2000.
- [22] G. Yang, Z. Yang, "PAPR Reduction in the OFDM System Employing Tone Reservation Based On FFT/IFFT," *IEEE International Conf. in Central Asia on Internet*, pp. 1-4, Sept. 2007.
- [23] Md. I. Abdullah, Md. Z. Mahmud, Md. S. Hossain, Md. N. Islam, "Di Comparative Study of PAPR Reduction Techniques in OFDM," *ARPJN Journal of Systems and Software*, vol. 1, no. 8, Nov. 2011.

- [24] H. G. Ryu, J. E. Lee, J. S. Park, "Dummy Sequence Insertion (DSI) for PAPR Reduction in the OFDM Communication System," *IEEE Trans. on Consumer Electronics*, vol. 50, Issue 1, pp. 89-94, Feb. 2004
- [25] L. J. Douglas, C. Tuna, "Tone Injection With Aggressive Clipping Projection For OFDM PAPR Reduction," *IEEE International Conf. on Acoustics Speech and Signal Processing*, pp. 3278-3281, March 2010
- [26] T. Jiang and Y. Wu, "An Overview: Peak-to-average power ratio reduction techniques for OFDM signals", *IEEE Trans. Broadcasting*, vol. 54, no. 2, pp. 257–268, Jun. 2008.
- [27] X. Li, L. J. Cimini, "Effects of Clipping and Filtering on the Performance of OFDM," *IEEE Vehicular Technology Conference*, vol. 2, no. 5, May 1998.
- [28] H. G. Ryu, B. I. Jin, I. B. Kim, "PAPR reduction using soft clipping and ACI rejection in OFDM system," *IEEE Trans. on Consumer Electronics*, vol. 48, no. 1, pp. 17-22, Feb. 2002.
- [29] R. V. Nee, A. Wild, "Reducing the Peak to Average Power Ratio of OFDM," *IEEE Veh Tech. Conf.*, vol. 3, pp. 272-276, May 1998.
- [30] P. Foomooljareon, W. A. C. Fernando, "Input Sequence Envelope Scaling in PAPR Reduction of OFDM," *IEEE International Symposium on Wireless Personal Multimedia Communications*, vol. 1, pp. 140-144, Oct. 2002.
- [31] C. E. Tan and I. J. Wassell, "Data bearing peak reduction carriers for OFDM systems," *4th International Conf. on Inform., Commun. and Signal Processing*, vol.2, pp. 854-858, Dec. 2003.
- [32] S. S. Jeng, J. M. Chen, "Efficient PAPR Reduction in OFDM Systems Based on a Companding Technique With Trapezium Distribution," *IEEE Trans. on Broadcasting*, vol. 57, no. 2, pp. 291-298, June 2011.
- [33] X. B. Wang, T. T. Tjhung, C. S. Ng, "Reduction of peak-to-average power ratio of OFDM system using a companding technique," *IEEE Trans. on Broadcast.*, vol. 45, no. 3, pp. 303–307, Sept. 1999.
- [34] A. R. S. Bahai, B. R. Saltzberg, M. Ergen, *Multi-carrier Digital Communication: Theory and Applications of OFDM*, New York: Springer, 2004.
- [35] S.R. Mallipeddy, R.S Kshetrimayaum, "Impact of UWB interference on IEEE 802.11a," *National Conf. on Commun.*, pp. 1-5, Jan. 2010.
- [36] Y. G. Li, G. L. Stuber, *Orthogonal frequency division multiplexing for wireless communications*, 1st ed., New York: Springer, 2006.

- [37] A. Yiweak, C. Pirak, "Intercarrier Interference Cancellation Using Complex Conjugate Technique for Alamouti-Coded MIMO-OFDM Systems," *International conf. on Electrical Engineering/Electronics Computer Telecommun. and Information Tech.*, pp. 1168-1172, May 2010.
- [38] ETSI, "Radio Broadcast Systems: Digital Audio Broadcasting (DAB) to mobile, portable and fixed receivers," European Telecommunications Standards Institute ETSI EN 300 401, Nov. 1994.
- [39] P. Shelswell, "The COFDM modulation system: The heart of digital audio broadcasting," *J. of Electronic and Commun. Eng.*, vol. 7, pp. 127-135, June 1995.
- [40] J. Stott, "The DVB terrestrial (DVB-T) specification and its implementation in a practical modem," International Broadcasting Convention, pp. 255-260, Sep. 1996.
- [41] ETSI, "Digital Video Broadcasting (DVB); framing structure, channel coding, and modulation for digital terrestrial television (DVB-T)," European Telecommunications Standard Institute ETSI EN 300 744, Nov. 1999.
- [42] ISO, "Information technology - generic coding of moving pictures and associated audio information: Part 2 video," International Organisation for Standardization 13818, 2000.
- [43] J. Tellado-Mourelo, "Peak to Average Power Reduction for Multicarrier Modulation," Ph.D. dissertation, Dept. Elect. Eng., Stanford University, Calif, USA, 1999.
- [44] O. Edfors, M. Sandell, *An Introduction to Orthogonal Frequency Division Multiplexing*, Division of Signal Processing, Luleå University of Technology, Research Report, Sep. 1996.
- [45] L. Hanzo, W. Webb, T. Keller, *Single and Multi-carrier Quadrature Amplitude Modulation*, Chichester: IEEE Press and John Wiley & Sons, 2nd ed., 2000.
- [46] [46] S. H. Han, J. H. Lee, "An Overview of Peak-to-Average Power Ratio Reduction Techniques for Multicarrier Transmission," *IEEE Trans. on Wireless Commun.*, vol 12, no. 2, April 2005.
- [47] X. Gu, S. Baek, Suwon Park, "PAPR reduction of OFDM signal using an efficient SLM technique," *12th International Conf. on Advanced Commun. Tech.*, vol. 1, pp. 324-328, Feb. 2010.
- [48] G.T. Zhou and L. Peng, "Optimality Condition for Selected Mapping in OFDM," *IEEE Trans. on Signal Processing*, vol. 54, no. 8, pp. 3159-3165, Aug. 2006.
- [49] Ke-Lin Du, M. N. S. Swamy, *Wireless Communication Systems: From RF Subsystems to 4G Enabling Technologies*, 1st ed., Cambridge: Cambridge university press, 2010.

- [50] John G Proakis, Masoud Salehi, *Digital Communication*, 5th Ed., New York: McGraw-Hill, 2008.
- [51] N. L. Johnson, S. Kotz, N. Balakrishnan, *Continuous Univariate Distributions*, 2nd ed. New York: Wiley, 1995.
- [52] A. Papoulis, *Probabilities, Random Variables, and Stochastic Processes*, 4th ed., New York: McGraw-Hill, 2002.
- [53] Fuqin Xiong, "M-ary Amplitude Shift Keying OFDM System," *IEEE Trans. Commun.*, vol. 51, no. 10, pp. 1638-1642, 2003.

LIST OF PUBLICATIONS

- [1] P. Bhatti, K. Singh, "BER and PAPR Analysis of GMSK-OFDM using Selective Mapping Clipping Technique," Communicated to *Wireless Personal Commun.*