

PERFORMANCE ANALYSIS OF VARIOUS MULTIPLEXING TECHNIQUES

A Dissertation Submitted in partial fulfillment of the requirements for the award
of the degree of

Masters of Engineering

In

Electronics and Communication Engineering

Submitted by
Ankit Kumar

Roll No. : 801461004

Under the guidance of

Dr. R. S. Kaler

(Senior Professor, ECED)



**DEPARTMENT OF ELECTRONICS AND COMMUNICATION
ENGINEERING, THAPAR UNIVERSITY**

**(Established under the section 3 of UGC Act, 1956)
PATIALA – 147004 (PUNJAB)**

August, 2016

CERTIFICATE

I, Ankit Kumar, hereby declare that the work which is being presented in the dissertation entitled "Performance Analysis of Performance Analysis of Various Multiplexing Techniques" is an authentic record of my study carried out as per requirement for the award of degree of M.E (ECE) at Thapar University, Patiala, under the supervision of Dr. R S KALIB (Senior Professor), ECED

Date: 13/08/2016

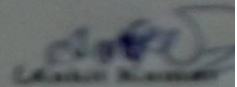

Ankit Kumar

REG-442004

It is certified that the above statement made by the student is correct to the best of my knowledge and belief.

Date: 13/08/2016

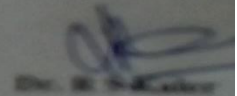

Dr. R S Kalib

Senior Professor

ECED

Countersigned by:



Dr. Surjit Malhotra
Professor & HOD
ECED, Thapar University



Dr. S.S. Bhatia
Dean of Academic Affairs
Thapar University

ACKNOWLEDGEMENT

First of all, I would like to express my gratitude towards **Dr. R S KALER**, Senior Professor, Electronics and Communication Engineering Department, Thapar University, Patiala for his patient guidance and support throughout this report dissertation. I am truly very fortunate to have the opportunity to work with them. I found their guidance to be extremely valuable.

I am also thankful to our **Head of the Department, Dr. Sanjay Sharma, ECED** for providing us ample environment in carrying this work.

Finally, I would like to extend my gratitude to all those persons who directly or indirectly helped me in the process and contributed towards this work.



Ankit Kumar

801461004

ABSTRACT

The effect of optical hybrid sensor based on wavelength division multiplexed technique (WDM) is studied using Photonics crystal fiber and Fiber Bragg Grating (FBG). Full Duplex scheme is used in this system to receive and transmit the data at same time for fast processing. The Finite difference time domain photonics simulation software (FDTD) is helpful in observing the variation in reflection and the transmission power spectra of the photonic gratings. Using line defects we created two linear waveguide, further it is used as optical sensor. The system can be used as in communication filed for data transmission and also used in sensing application to sense the property and deformation of object.

Orthogonal Frequency Division Multiplexing (OFDM) uses multicarrier modulation (MCM) in which the digital data are encoded over different lower rate subcarriers. OFDM have various advantages over conventional modulation techniques such as its robustness with respect to the channel dispersion and its simplicity regarding channel and phase approximation in a time-varying atmosphere. Currently various researches have recognized that OFDM is a one of the most prominent and promising technique for optical communications, while its implementation and application in the optical systems is incomprehensive surveillance.

The objective of this dissertation is to look into the implementation of different multiplexing transmission techniques and for this purpose Optisystem 14 and OptiFDTD software are being used which helps to design many configurations concerning optical communications.

Firstly, we have designed a full duplex wavelength division multiplexed hybrid sensor for different applications. Secondly, we studied Coherent Optical Orthogonal Frequency Division Multiplexing with the help of Dual Polarization QPSK modulation scheme, using coherent detection in optical communication system

TABLE OF CONTENTS

CONTENTS	Page No.
CERTIFICATE	i
ACKNOWLEDGMENT	ii
ABSTRACT	iii
CONTENTS	iv
LIST OF FIGURES	vii
LIST OF TABLES	ix
LIST OF ABBREVIATIONS	x
CH 1 INTRODUCTION	1
1.1 WDM	1
1.2 Sensors	2
1.3 Optical Fiber Sensors	3
1.3.1 Operating Principle	4
1.3.2 Classification of Optical Fiber Sensors	5
1.3.3 Field of Application	5
1.3.4 Issues related to Optical Fibre	6
1.4 Fiber Bragg Grating	6
1.5 Photonics Crystal Fiber	8
1.6 Light Guidance Mechanism and Characteristics of PCFs	9
1.7 Application of PCFs	10
1.8 OFDM	11
1.9 Chronological Expansion and practical execution of OFDM	11
1.10 OFDM BASICS	13
1.11 OFD M System Description	15
1.11.1 Implementation of DCT	16

1.12	Optical OFDM (O-OFDM)	18
	1.12.1 Optical Channel : Chromatic Disperstion	19
	1.12.2 Optical Modulation Technique	19
	1.12.3 Detection Techniques	23
	1.21.4 CO-OFDM	24
1.13	Advantages of OFDM	25
1.14	Objective of Dissertation	26
1.15	Organization of Dissertation	27
CH 2 LITERATURE SURVEY		29
CH 3 DESIGN OF A FULL DUPLEX WAVELENGTH MULTIPLEXED HYBRID SENSOR FOR DIFFERENT APPLICATIONS		36
3.1	Introduction	36
3.2	Mathematical Analysis	38
3.3	Simulation Setup	39
3.4	Results	40
3.5	Conclusion	42
CH 4 STUDY OF COHERENT DETECTION IN CO-OFDM IN OPTICAL COMMUNICATION SYSTEM		43
4.1	Introduction	43
4.2	Simulation Setup	44
4.3	Results	45
4.4	Conclusion	49
CH 5 CONCLUSION AND FUTURE SCOPE		50
5.1	Conclusion and Recommendation	50
5.2	Future scope	50
REFERENCES		52

LIST OF FIGURES

NO.	TITLE	PAGE NO.
1.1	WDM System	2
1.2	Basic Block Diagram of Fiber Optic Sensor	4
1.3	(a) Extrinsic Sensor (b) Intrinsic Sensor	5
1.4	Transmission & Receiving spectra of a FBG	7
1.5	Cross-Sectional representation of (a) SMF (b) SC-PCF (c) HC-PCF	10
1.6	Chronological expansion and practical execution of OFDM	12
1.7	FDM: Analog Transmitter	13
1.8	Spectrum displaying an OFDM symbol with overlapping subcarrier	14
1.9	Module for OFDM System	16 ¹⁵
1.10	Time-domain representation of OFDM signals for complete single OFDM symbol	17
1.11	4 QAM mapping	17
1.12	4 QAM demapping and slicing	18
1.13	Schematic and typical curve of laser diode.	20
1.14	Schematic Intensity Modulation and Direct Detection	21
1.15	Mach-Zehnder modulator (MZM)	22
1.16	I-Q Mach-Zehnder modulator (MZM)	22
1.17	Block diagram of a coherent optical OFDM (CO-OFDM) system	24
1.18	High bandwidth efficiency achieved due to orthogonal subcarrier	26
1.19	High peak on OFDM system	26
3.1	A Full duplex WDM Hybrid sensor using line defects	27
3.2	Variation of Amplitude value as function of width of waveguide	39
		40

3.3	Reflection of FBG 1 and FBG2 as function of wavelength	41
3.4	Transmission for FBG1 and FBG2 as a function of wavelength	41
4.1	Block Diagram of CO-OFDM with DP-QPSK	45
4.2	Optical spectrum after transmitted signal (a) after modulation (b) at 10 km(c) at 100km (d)300km from the channel	46
4.3	BER a function of distance for different subcarriers	47
4.4	Constellation diagram for coherent detector for X polarized signal at (a) 10 km (b) 100km (c) 300 km	48
4.5	Constellation diagram for coherent detector for Y polarized signal at (a) 10 km (b) 100km (c) 300 km	49

LIST OF TABLES

NO.	TITLE	PAGE NO.
1.1	Comparison between Wireless OFDM and O-OFDM	18
2.1	Literature survey	34

LIST OF ABBREVIATIONS

ADC	Analog to Digital Converter
AFC	Adaptive Frequency Correction
BER	Bit Error Rate
CD	Chromatic Dispersion
CE-OFDM	Constant Envelope Orthogonal Frequency Division Multiplexing
CFDM	Coded Frequency Division Multiplexing
CO-OFDM	Coherent Optical Orthogonal Frequency Division Multiplexing
CP	Cyclic Prefix
CSR	Carrier to Sideband Ratio
CW	Continuous Wave
DAC	Digital to Analog Converter
DCF	Dispersion Compensating Fiber
DDO-OFDM	Direct Detection Optical Orthogonal Frequency Division Multiplexing
DFT	Discrete Fourier Transform
DMT	Discrete Multi-Tone
DTT	Digital Terrestrial Television
DRA	Distributed Raman Amplification
EDC	Electronic Dispersion Compensation
EDFA	Erbium Doped Fiber Amplifier
EDFA	Erbium Doped Fiber Amplifier
FBG	Fiber Bragg Grating
FDTD	Finite Difference Time Domain
FFT	Fast Fourier Transform
ICI	Inter Carrier Interference
IDFT	Inverse Discrete Fourier Transform

ISI	Inter Symbol Interference
IFFT	Inverse Fast Fourier Transform
IMD	Inter Modulation Distortion
IM/DD	Intensity Modulated/ Direct Detection
LM-DD	Linearly Mapped Direct Detection
LS	Least Sequence
MCM	Multi Carrier Modulation
MZM	Mach Zehnder Modulator
NLD	Non Linear Distortion
NLM-DD	Non Linearly Mapped Direct Detection
OFDM	Orthogonal Frequency Division Multiplexing
OOFDM	Optical Orthogonal Frequency Division Multiplexing
OSNR	Optical Signal to Noise Ratio
PAPR	Peak to Average Power Ratio
PCF	Photonics Crystal Fiber
PD	Photo Detector
PLL	Phase Locked Loop
PMD	Polarization Mode Dispersion
PSK	Phase Shift Keying
QAM	Quadrature Amplitude Modulation
ROP	Received Optical Power
PM-PCF	Polarization Maintaining Photonic Crystal Fiber
SCM	Single Carrier Modulation
SC-PCF	Solid Core Photonic Crystal Fiber
SLM	Selective Mapping

CHAPTER 1

INTRODUCTION

The initiation in internet services and extensive distribution of personal computers has brought a significant change in our life over last decades. The facility to communicate, uncover information, video conferencing, medical support, and so numerous other aspects of life, are obtainable by the way of an easy mouse-click. The challenge regarding improved multimedia services and an escalating quantity of Internet customers has specified an improved demand for optical network, in all domains like metropolitan networks (MAN), long-haul systems, and local area networks (LAN). Accordingly, the requirement to broadcast bigger chunks of information taking assistance from single optical fiber, including with the necessity of reasonably priced and extra competent distribution nodes in LAN [1], has result into the escalating significance of wavelength division multiplexing (WDM) schemes.

1.1 WAVELENGTH DIVISION MULTIPLEXING

WDM helps us to utilize the significant portion of the accessible bandwidth fiber by permitting several individual signals to be transferred concurrently on particular fiber, with every signal exists on a different wavelength. Recognition and routing of individual signals can be accomplished in parallel, with the wavelength determining communication path by acting as the signature address of the origin, destination or routing. Components are hence essential which are wavelength selectors, recovery, or routing of specific wavelengths. In a straightforward WDM system, depicted in Fig. 1.1, each laser must be emitting light with a singular wavelength while all these lasers' sources are multiplexed collectively against a distinct optical fiber.

After being communicated with the assistance of an excessive high bandwidth optical fiber, the collective optical signals ought to be de-multiplexed at the receiver corner. One approach is mentioned in here, that is to disseminate the entire optical power into individual output ports and afterward, at each receiver the requirement of tunable optical filter to selectively recovering only individual wavelength simultaneously. Every laser source is modulated at a specified rate and the total cumulative capacity being passed on the length of the huge bandwidth fiber is the summation of the individual lasers bit rate.

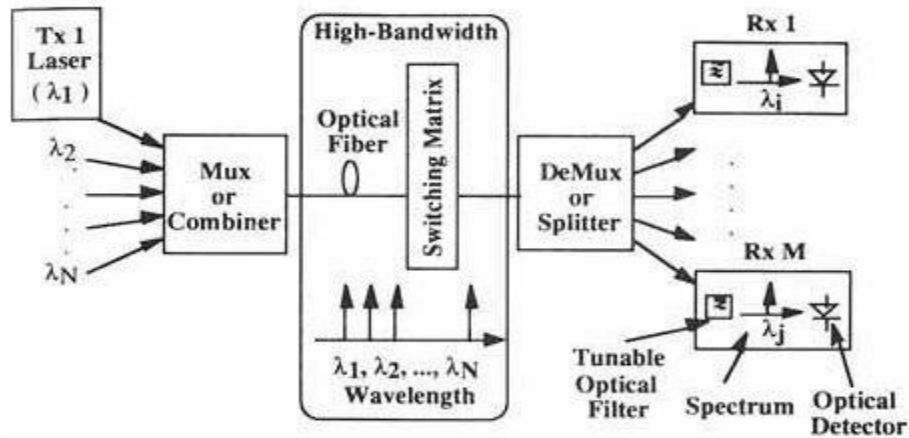

Figure 1.1: WDM Network

1.2 SENSORS

Sensing is vital equipment in the application areas like civil, aeronautics, health and other industrial uses. Several of these applications require the perception of remote sensors, where data is attained from areas which are clearly inaccessible. This notion calls for three simple constituents:

1. Sensor: A device which delivers information about the physical, biological, and chemical quantity of interest (e.g., density, temperature, pH etc.) by determining it and turning it into a format (e.g., electrical, optical etc.) which is effortlessly communicated and processed.
2. Transmission lines
3. A platform to support transformation of transmitted data into a set-up which is easily interpreted by human senses, i.e., shows the received info in audio or visual medium.

The transmission lines generally used as copper cables which leave us with a choice to select from the numerous varieties of accessible sensors. If we accustom optical fibers as some sensor, this will allow us to interrelate with parameters (physical, chemical, or biological) with light to construct modulated optical signal comprising of information and the quantity which has to be interconnected. This arrangement can easily gain access by the receiver with the help of any photo detector, which could translate light in terms of its equivalent voltage (volts) or current (amperes). The elementary motive for fiber-optic sensors to be given more priority than previously used conventional sensors are [2]:

1. Transmission via electrically powered cables undergo with the external interference from electromagnetic fields. In contrast, many optical fibers are invulnerable to these interferences.
2. Optical fibers are compact and are not so heavy when compared with electric cables. This quality come as a benefit where miniaturization is decisive, e.g., in vehicles (spaceship or airliners business).
3. Optical fibers are able to endure dangerous circumstances considering extraordinary temperature.
4. It has the potential to multiplex fiber optic sensors successfully in a single network.
5. An optical fiber sensor performs multifunctional sensing.

Thus, fiber optic sensors have almost all the benefits of optical fibers and therefore they are exceptional runners for environmental monitoring.

1.3 OPTICAL FIBER SENSORS

1.3.1 Operating Principle

An elementary fiber optic sensing scheme comprises of a light generating source, optical fiber, simple transducer or sensing element and a detector. Sensor type whether intrinsic or extrinsic, depends upon the fact that whether a separate transducer is functional in the network or not. Operating the fiber optical sensor by doing modulation technique in one or more factors of the system (e.g., polarization, phase, frequency, intensity, etc.) causing the change in several features of optical signal that is detected at the receiver [3]. Fig. 1.2 shows an uncomplicated optical fiber sensing arrangement, where the light generating source that will be guided through some optical fiber. Then it is exposed with an external quantity and in the end this modulated optical signal is communicated towards the detector [4]. The information with respect to input parameter can approximately be achieved by studying the modulated light signal. The sensor system is capable of functioning in reflection or transmission manner, dependent upon the category of sensor and its standard of procedure. There are several categories of optical fibers which is being used in the sensor modeling, long period gratings,

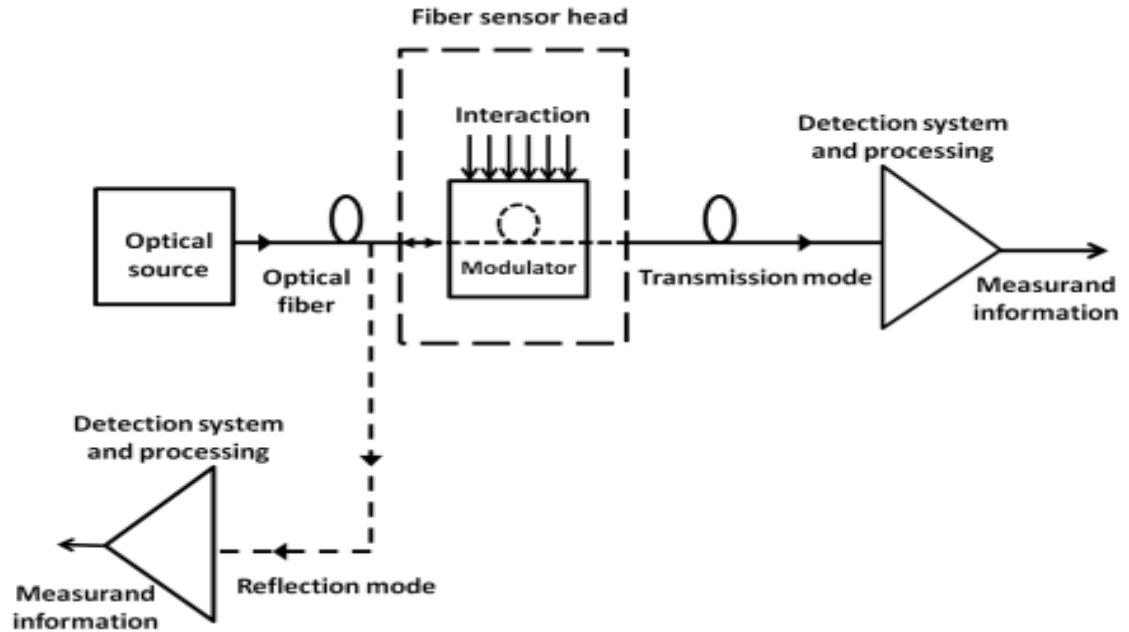

Figure 1.2: Basic block-diagram of fiber-optic sensor

Fiber Bragg gratings, photonic crystal fibers, to name some. Every design has some profits over another. The optical sensors can not only sense using the received modulation parameters but also from the techniques in which probing of matter is done by the photons. These photons can either be scattered or absorbed. These procedures have so much of use in the field of chemical sensing.

1.3.2 Classification of Optical Fiber Sensors

Fiber optic sensor system can be categorized in:

1. Based on sensor location [2]

- a. Extrinsic sensors- In this range of sensor systems, the purpose of an optical fiber is to convey light signal to a sensor, which can be positioned anywhere close to, in front of or afterward the fiber; to inspect some measurand. Here, its behavior is similar as that of a transmission medium and will not have any relation regarding the attained data.

- b. Intrinsic sensors- In this range of sensor systems, some fragments of fiber, or the fiber itself perform as the sensor for analyzing the measurand. There is no necessity of light, which leaves the fiber to attain the data, since fiber carry out the task of sensor and cable concurrently.

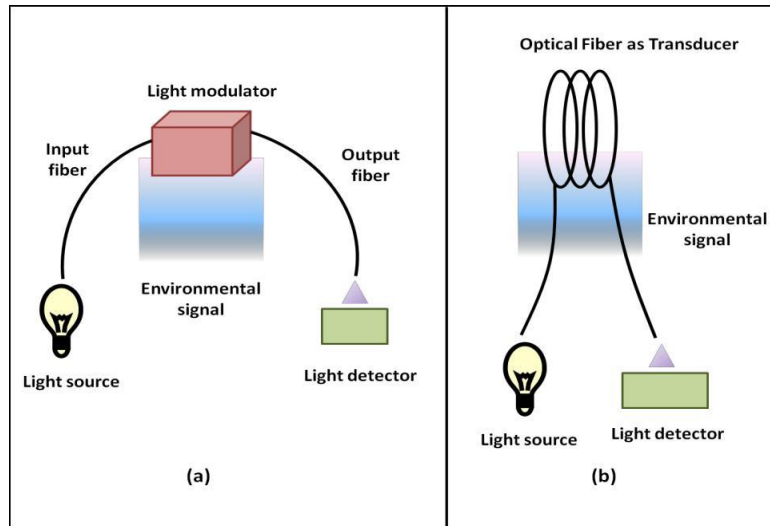

Figure 1.3: Sensor location: (a) Extrinsic sensor (b) Intrinsic sensor

2. Based on modulation of light

- a. Intensity
- b. Polarization
- c. Phase
- d. Wavelength

According to the application, physical sensors can be used for measuring temperature, pressure, etc. Chemical sensors are used in determining various parameters like pH content, spectroscopy, etc. and while using as biological sensors, it helps in identifying DNA, blood sampling, etc.

1.3.3 Fields of Application and Current Status

Fiber-optic sensors have flourished quickly in terms of quality and functionality and they are being managed extensively in numerous regions like:

1. Toxic waste monitoring
2. Civil engineering purposes like Structural monitoring
3. Biotechnology and Biomedical Science
4. Ground water observing
5. Process control
6. Titrimetric procedures
7. Military/ aeronautical
8. Electrical functionalities & Automation industry

Better-quality and durable performance of optical fibers alongside a decrement in expense of optical fiber sensors, this has made it an appealing prospect over conventional sensors. The fulfillment of such demands which are application specific and can't be appeased powerfully with conventional sensors, e.g., high temperature and pressure monitoring in the coal and gas sector. Aerospace and civil industrial sectors are also receiving aid from fiber-optic sensors, as it can ensure safety enhancement by giving early warning related to life-threatening failures in buildings and construction area. Implanting fiber optic sensors on smart structures encourages the safety of advanced structures, machines and devices [5].

1.3.4 Issues Related to Optical Fiber Sensors

However optical fibers present numerous aids over the conventional sensors, some worries also appear in this technology. Some issues related to them are [6],

1. Cost: Optical fiber sensors are overpriced.
2. Ambient light can interfere with the signal thus measurements have to be carried out in dark.
3. Response time: It is time-consuming, particularly when multiphase sensing techniques are used.
4. Long-term stability: Since optical fiber technology is still in its initial state, very less data is gathered about its durable and reliable nature.
5. Dynamic range is smaller.
6. The data attained from the sensors may not be straight forward, "since output is subjective to fluctuations due to other parameters".

1.4 FIBER BRAGG GRATING (FBG)

In 1978, Ken O. Hill revealed the consequence of photo-sensitivity for Germanium doped optical fibers under the exposure to UV light, the refractive index of the core is altered permanently [7] [8]. Hence, when the optical fibers are revealed to a periodic pattern of ultraviolet light, as a result, the gratings are produced. The gratings are alternating regions of high and low refractive indices within the core of an optical fiber. On every occasion, when a broad spectrum light beam imposes on the grating, a fragment of its energy is transmitted through and the some fragments of power are getting reflected in Fig. 1.4. The recurring grating

turns into a filter, reflecting only a pivotal narrow wavelength range, centered on a peak wavelength. This wavelength is acknowledged as Bragg wavelength (λ_B). A Fiber Bragg grating sensor is a wavelength-dependent filter/reflector, which employs the principle of Bragg reflection. The gratings are a series of parallel lines neighboring together, which are printed on the core of an optical fiber. The grating length is typically lies in the range near to 1 mm and 25 mm [9].

$$\lambda_B = 2 * n * \Lambda \quad (1.1)$$

Where n is the average refractive index and Λ is the grating period.

The Bragg wavelength is perceived as peak in the reflected spectrum. On contrary, looking at the transmitted spectrum a gap is witnessed.

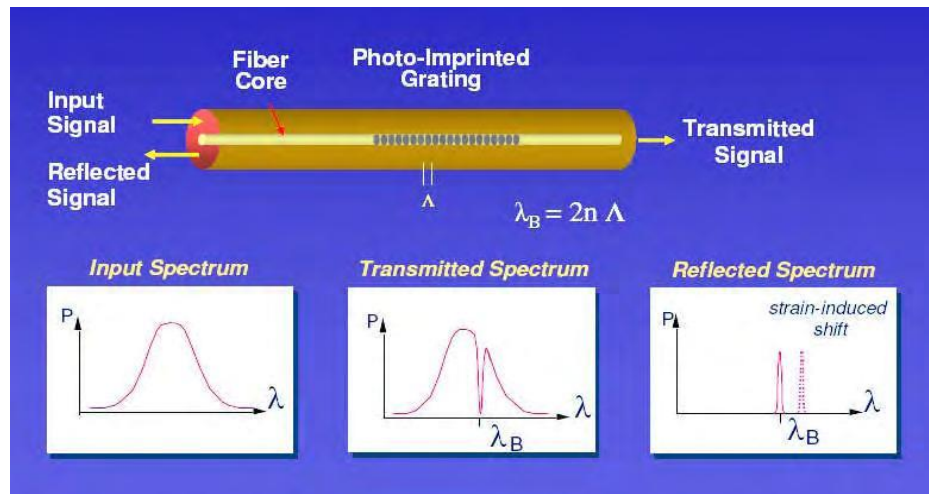

Figure 1.4: Transmission and Reflection Spectra of a Fiber Bragg Grating

One of the fundamental gains of FBG sensors is that information is coded as wavelength change and the information is not disturbed by rise and fall of light power. Generally conventional systems are based on scanning the wavelength by illuminating the sensors through tunable laser which deals with Wavelength Division Multiplexing (WDM). The principle behind this is: lots of Bragg gratings are combined on a single optical fiber and each provided with a different Bragg wavelength. In that way, devices rely on the individual wavelength of each FBG to pin down each sensor. Each communication channel of the examination system is multiplexed onto a single fiber. Fiber Bragg Gratings have numerous benefits as sensors for Structural Health Monitoring. They can possibly interchange conventional sensors in the future, like resistance strain gages, PZTs or accelerometers. More explicitly, their main benefits consist of [10]:

1. Resistive against electromagnetic interference (non-conductive)
2. Perfectly passive (electrical power compulsory). They can be sited in high voltage and highly explosive atmospheric areas
3. Compact and lightweight
4. Very low fiber loss at 1550 nm (typical wavelength)
5. Use in cryogenic ambience due to low thermal conductivity
6. Long term stability

However, there are also some drawbacks regarding FBGs. The main of them include [11]:

1. Ingress and egress points can very certainly be damaged after embedded
2. Optical fibers need satisfactory protection in order to damage control
3. For strain FBGs, each time a temperature compensation sensor is required

FBGs are exploited in civil engineering for long term strain examining in structures, such as bridges, and tunnels. The maintenance budgets of the configurations are abridged prominently by the early recognition of wearing away of the structure. FBGs applications are also available in the geo-technical field, corresponding to coal mining and gas exploration, in the railway contact lines and in the railway pantographs, because they provide electrical insulation. In supplement, FBGs helps in surveillance of the internal corrosion in pipelines. FBGs have started to be employed in fields like aeronautical and aerospace territory. FBG based instructor proposals for temperature monitoring in the electric propulsion subsystem, and for temperature monitoring in satellite structural walls and floor.

1.5 PHOTONIC CRYSTAL FIBER (PCF)

PCF's set up is an emergent category of optical fibers that associate assets of photonic crystals and optical fibers into one. PCF geometry is characterized as a periodic grouping of air-filled capillaries running along the entire length of the fiber, centered on a hollow or solid core [4]. The variation among conventional OF and PCF lies on the statement that waveguide properties of PCF are not due to fluctuating configuration of glass, but due to its internal periodic structure consisting with air holes. Even though conventional OFs demonstrate an admirable performance in fiber telecommunication and have many advantages over standard sensors, there are some constraints which have restricted the use of optical fiber as sensors. Some of them are stated

below [12]:

1. The selection of material for fabrication of the core and the cladding is restricted as thermal, optical and chemical properties of both the materials should counterpart with each other.
2. The refractive index profile and the geometry of OFs hamper the calculation like dispersion, inherent losses, birefringence and non-linearity.

So, there was a need to introspect additional areas of fiber optic technology to take in the returns of optical fibers by choking their limitations. The development of PCFs has become a breakthrough in optical fiber technology due to possession of astonishing properties, permitting them to conquer many limitations faced by conventional OFs.

1.6 LIGHT GUIDANCE MECHANISM AND CHARACTERISTICS OF PCF

Customary SMFs reside of a doped core which is bordered by a pure silica cladding as shown in fig. 1.5(a). Refractive index of the core must be higher than that of the cladding for appropriate transmission of light. As talked over earlier, PCF configuration demands cladding composed with air capillaries, centered on a hollow or solid core. In consequence, PCFs are separated into two sorts on the basis of their geometry [13]:

1. Solid-core PCFs- The cross-section of SC-PCFs takes account of periodically organized air capillaries all over the solid core. This kind of geometry helps in lowering the effective refractive index of the cladding, when a single material is used for engineering. A general SC-PCF is shown in fig. 1.5(b).
2. Hollow-core PCFs- As advocated by it stag, HC-PCFs is established on a central hollow (air) core with cladding constructed of corresponding air-holes. This grants a negative core-cladding refractive index difference. Fig. 1.5(c) shows a sketch of HC-PCF.

While dealing with PCF, three physical features must be involved: the diameter of the core (d) (for SC-PCF, diameter of ring established by innermost layer of air-holes), diameter of air-holes of cladding, h and the pitch, Λ , which is the distance concerning the centers of two consecutive air holes [13].

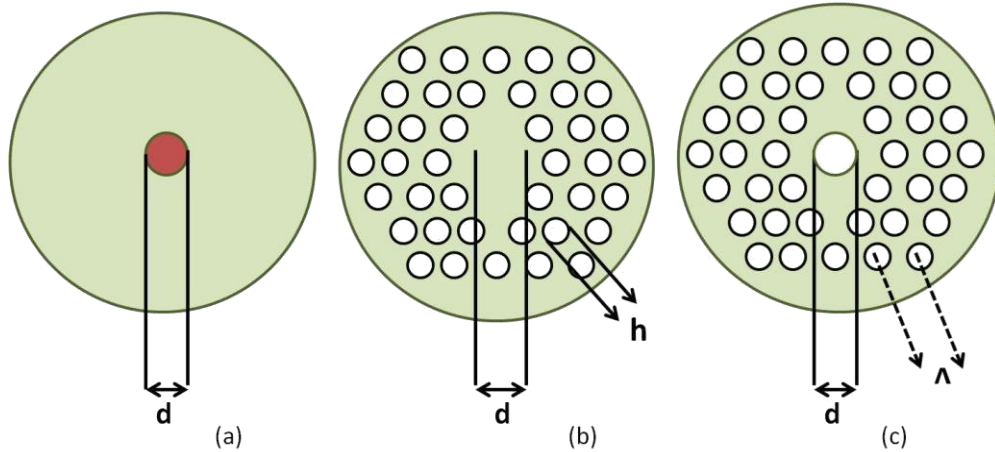

Figure 1.5: Cross-sectional representation of (a) SMF (b) SC-PCF (c) HC-PCF

Thus, by fluctuating these constraints in grouping with the linking of material refractive index and the lattice geometry, construction and fabrication of PCFs come to be very flexible. Such liberty of structural adaptation is not imaginable while using conventional OFs.

1.7 APPLICATIONS OF PCF IN SENSING

PCFs have various purposes, when someone makes an approach towards sensing since it is responsible for changing various parameters, which customary optical fibers cannot provide. Some of these purposes are

1. The shape, magnitude and number of the cladding holes and/or that of the core
2. Mode profile
3. Fiber transmitting spectrum
4. Dispersion & different Non linearity
5. Fill factor
6. Birefringence

To some extent these procedures could be tuned to accomplish values which are not manageable with standard optical fibers. Also, the occurrence of air holes in the cladding allows light proliferation in air or attachment of gases/liquids into them. This is responsible for a well-controlled interaction background concerning the sample and the light contained by this fiber, which was before impossible with customary OFs [14]. While working with bio-sensing, PCFs could work in the field of DNA recognition etc.

1.8 ORTHOGONAL FREQUENCY DIVISION MULTIPLEXING

Orthogonal Frequency Division Multiplexing (OFDM) has become a sensational modulation and multiplexing technique which is widely applied in numerous wireless and wired communication networks because of its spectrum efficiency and channel robustness. OFDM is associated with a higher prominence when it comes to multicarrier modulation (MCM) which encodes chunks of digital data components in different lower rate subcarriers. OFDM, is a modulation and multiplexing method comprises the basis of several telecommunications principles including wireless local area networks (WLAN), digital radio distribution, and digital terrestrial television (DTT). OFDM is also the source of almost all the DSL standards, and within this condition OFDM is commonly identified as discrete multitone (DMT). In recent times, many researchers have started to pay more interest to apply this OFDM procedure with the help of multi-carrier modulation (MCM), instead of single carrier modulation (SCM) in optical fiber communication [21] because of its competence in diminishing the consequence of selective fading, decreasing chromatic dispersion and lessening Inter-symbol Interference (ISI). The interest in Optical orthogonal frequency division multiplexing (O-OFDM) has been increased in current times as it has developed for extensive distance and has the competence to equalize polarization mode dispersion (PMD) and chromatic dispersion (CD) efficiently. Realization of OFDM and its utilization in wavelength division multiplexing (WDM) system [22]. To accomplish much higher efficiency in the spectrum or in accomplishing lower channel equalization, OFDM grosses assistance from the techniques like Fast Fourier Transform (FFT). O-OFDM befitted into an acceptable technology through which we are competent to design bandwidth adjustable transponders for spectral efficient optical setups. Phase modulation using O-OFDM and coherent detection is really helpful in spectral efficiency, robust behavior towards the nonlinearities, and for broadcasting in elastic networks [23].

1.9 CHRONOLOGICAL PERSPECTIVE OF OFDM:

In 1966, Chang primarily presented the notion of an OFDM in a seminal paper [21]. This notion remained in scrutiny by many researchers like Saltzberg near 1967, and factually “OFDM” was first performed in his discrete patent during 1970’s [22]. The suggestion to construct the orthogonal signals by applying the properties of an FFT was derived in 1969 [24]. In 1980, the

cyclic prefix (CP) was proposed. For theoretical wireless applications, OFDM has begun to be examined in middle of 1980s. A manuscript on OFDM for mobile communication was issued by Bell Labs via Cimini during 1985 [25]. Around 1987, some traits of OFDM in radio distribution were scrutinized and its importance in merging forward error correction (FEC) and OFDM is deduced by Lassalle [26]. Because of this association, OFDM may also identify as Coded OFDM (C-OFDM). Then field of OFDM had been long developed due to peripheral concentration in military application. OFDM is now forms the basis of several telecommunications principles and is even the foundation of nearly all DSL standards, and within this situation OFDM is commonly acknowledged as discrete multitone (DMT). The synopsis of basic and practical manifestation of OFDM across the range of communication systems is shown in Fig. 1.6. OFDM in optical communication systems has developed intensely in recent years, and numerous level of research papers on the speculative and applied performance and applications of O-OFDM in countless systems comprising optical wireless networks are present [27]. In the ending of 2000s, exploration on conducting long haul transmission of OFDM is preferential.

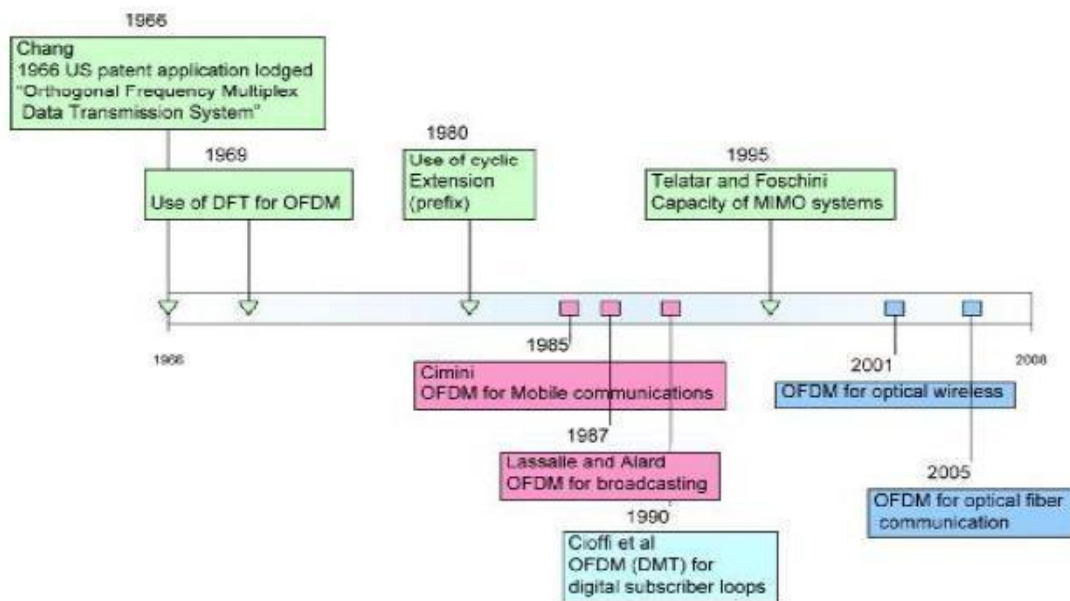

Figure 1.6: Chronological expansion and practical execution of OFDM

Two major ongoing topics has grabbed the focus of many researchers, i.e. coherent optical OFDM (CO-OFDM) and direct-detection optical OFDM (DDO-OFDM). DDO-OFDM is appropriate for low-cost and short reach applications, the CO-OFDM targets

towards the attainment of high spectrum efficiency and optical signal sensitivity at the receiver.

1.10 OFDM BASICS:

While using Frequency Division Multiplexing (FDM), the transferred signal is fragmented into a cluster of discrete signals, identified as subcarriers which are represented in the frequency domain. Then every single subcarrier is modulated by the means of some conventional modulation set up, and later they are mutually pooled to stimulate the FDM signal. Every single subcarrier during FDM is individually recovered at receiver. If every subcarrier signals achieves the orthogonality principle then it results in overlapping of spectrum and therefore the spectral efficiency of the signal is also improved. This procedure is also acknowledged as OFDM. With the help of Fig. 1.7, it accounts for the OFDM modulation schematically. Information at the bit rate of R is transmitted and divided into N parallel channels, each one of these signals are modulated with separate frequencies. Over each channel, the total bit rate is divided into equal parts at the rate of R/N . In each channel the data is going to be mapped to characterize as an information symbol and then augmented by its respective frequency. To form one OFDM symbol, these parallel information symbols are correspondingly summed. Therefore the time interval of each OFDM symbol is $T_s=N/R$

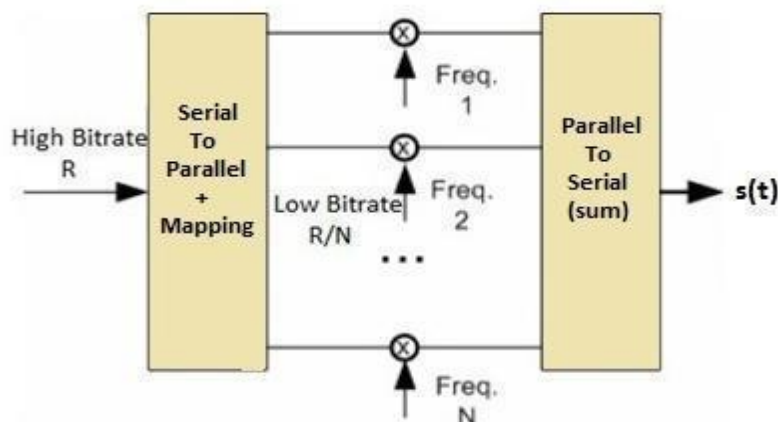

Figure 1.7: Frequency division multiplex: Analogue transmitter

1.10.1 Concept of orthogonality:

The property of orthogonality allows these manifold signals to be faultlessly transferred over the shared channel and identified with respect to the receiver and lacking interference. OFDM

signal in time domain is characterized as [31]:

$$s(t) = \sum_{i=-\infty}^{\infty} \sum_{k=1}^{N_{SC}} c_{ki} * s_k(t - iT_s) \quad (1.3)$$

$$s_k(t) = \Pi(t)e^{j2\pi f_k t} \quad (1.4)$$

$$\Pi(t) = \begin{cases} 1, & (0 < T < T_s) \\ 0, & \text{elsewhere} \end{cases} \quad (1.5)$$

Where c_{ki} is the i_{th} data symbol wrt k_{th} subcarrier, s_k presents the waveform for k_{th} subcarrier, f_k is the subcarrier frequency, N_{SC} is no. of subcarriers, $\Pi(t)$ is for pulse shaping function, T_s is symbol period.

The frequency which has to fulfill the orthogonality condition [31]:

$$f_k = k \frac{1}{T_s} \quad (1.6)$$

It specifies keenly that for accomplishment of orthogonality, every subcarrier requisitely divided with respect to its neighboring subcarrier by $1/T_s$. For some pair of subcarriers this property can be described by the under given expression [31]:

$$\int_{-T/2}^{T/2} \cos\left(\frac{2\pi n t}{T}\right) \cos\left(\frac{2\pi m t}{T}\right) dt = 0; m \neq n \quad (1.7)$$

Over the single time period, the area under this product must be zero in this case of m and n can be different natural numbers.

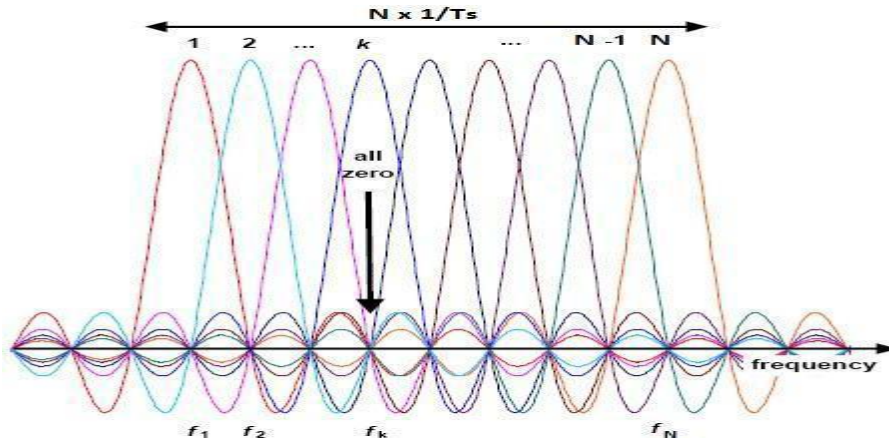

Figure 1.8: Spectrum displaying an OFDM symbol with overlapping subcarriers.

In Fig. 1.8, it is clearly displayed that the spectrum of OFDM character which comprises of partly covered subcarriers, where individually every subcarrier is disjointed with its neighbors by $1/T_s$ and is centered at f_k . Then the circumstance of orthogonality has been carried out and a good efficiency of the spectrum is accomplished. Irrespective of signal spectral overlapping, on the receiver side the recovery of these subcarriers are possible

without any inter-carrier interference (ICI) by using these panel of oscillators and low-pass filters for every subcarrier.

1.11 OFDM SYSTEM DESCRIPTION

The module of OFDM transmission system is made known in Fig. 1.9. At the transmitter, digital information which has been in encoded format is fed and split into N parallel streams at a higher rate. Each stream uses different modulation technique like QAM, PSK, etc. and is transposed into numerous symbol frames. These frames, which are employing the inverse discrete Fourier transform (IDFT) are modified with these subcarriers. IDFT is a procedure with which each symbol frame of OFDM must be converted rigorously from frequency domain to its equivalent time dominion. The cyclic prefix must be substituted into the OFDM symbol subsequently the IDFT maneuver is performed and at that time it is proceeded via digital-to-analog converter (DAC). After this, these signals will get up-converted in the frequency and the output after DAC will become baseband signal which will be transmitted.

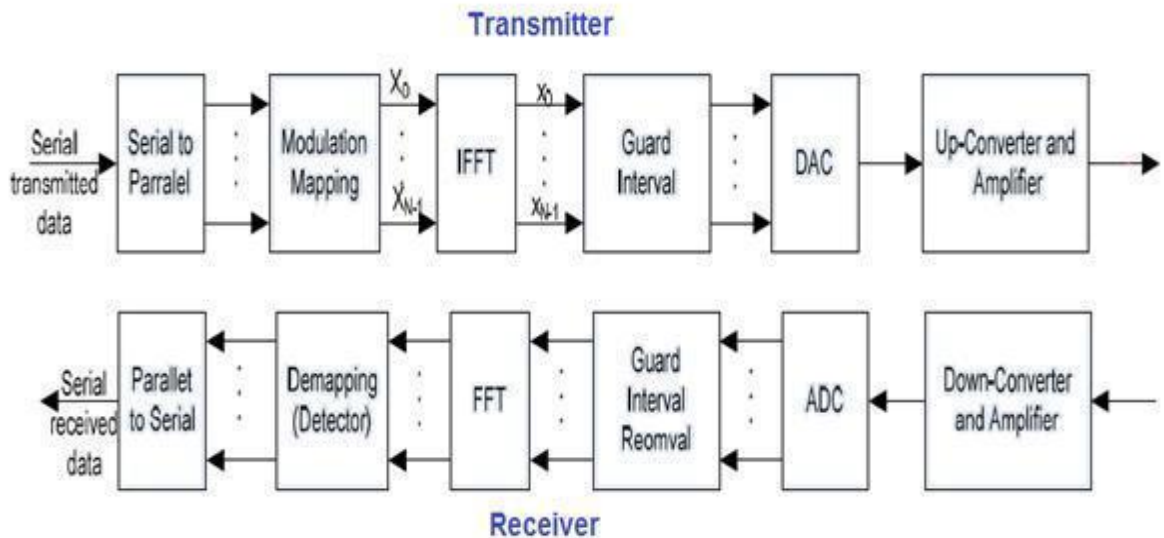

Figure 1.9: Module for OFDM system.

Now at receiver section, these signals are getting down-converted into baseband sign. Afterwards there is an analog-to-digital converter (ADC), these signals are again altered into digital from analog. These samples will be provided to the discrete Fourier transform (DFT) and rehabilitated into frequency domain, after getting rid from the guard interval then these data are finally distinguished as shown in Fig. 1.9.

1.11.1 Implementation of Discrete Fourier Transform:

Data are distributed in the frequency domain, at the cause end of this OFDM system, and all the records is demodulated into its corresponding time domain by using IFFT. If conjugate symmetry is enforced on these responsive data at that point every FFT output data are assured to be real-valued. By the side of the receiver, recuperation of these original data with FFT which allows adept enactment of modulation of data using multiple carriers [28]. This comparison of the forward and converse transform authorizes the same electrical structure, with minor amendments in both modulation and demodulation in transceiver. A large aggregation of subcarriers remain essential in OFDM so that the conducting channel distresses every subcarrier with flat channel, which primes into the multifarious design of the OFDM system comprising of many filters and oscillators. Weinstein and Ebert published that IDFT and DFT techniques ought to be recycled in OFDM modulation and demodulation [21].

The modulated signal can be represented in time domain as [31]:

$$x(t) = \sum_{n=0}^{N-1} X_n e^{j2\pi f_n t} \quad (1.8)$$

Where $f_n = f_0 + n\Delta f$, $n=0, 1, \dots, N-1$, and T_s is symbol duration, and Δf is sub channel spacing Δf is chosen to make N number of subcarriers orthogonal.

If the time domain signal $x(t)$ is sampled at the time interval of $T_{sa} = \frac{T_s}{N}$ then [31]

$$x_k = x(kT_{sa}) = \sum_{n=0}^{N-1} X_n e^{\frac{j2\pi f_n k T_s}{N}} \quad (1.9)$$

If $f_0 = 0$ then $f_n T_s = n$, then (1.10)

$$x_k = \sum_{n=0}^{N-1} X_n e^{\frac{j2\pi kn}{N}} = \text{IDFT}\{X_n\} \quad (1.11)$$

DFT and IDFT implementation of OFDM delivers two very crucial advantages, they are:

1. The precise value through which these complex multiplications is condensed from N^2 to approximately $N/2$ linearly with the number of subcarriers N , due to efficient IFFT/FFT algorithm.
2. When many numbers of subcarriers are necessary, IFFT/FFT implementation delivers easy OFDM architecture without overhauling much on intricate RF oscillators and filters.

Cyclic Prefix (C.P) for OFDM:

Alongside with modulation and demodulation of orthogonal subcarriers by IFFT and FFT, there

is a necessity to compensate dispersive channel that severely effects polarization mode dispersion and chromatic dispersion.

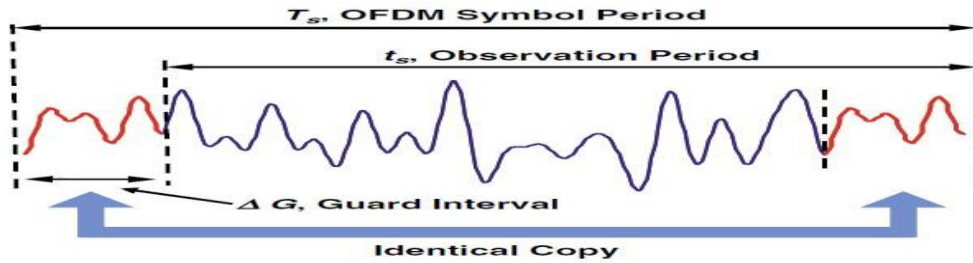

Figure 1.10: Time-domain representation of OFDM signals for complete single OFDM symbol. Therefore for each and every OFDM symbol, a guard time which is cyclically drawn out to introduce immediately after the IFFT to eradicate ISI and ICI [29-30]. Fig. 1.10 shows that every solitary OFDM symbol that is self-possessed of C.P as well as observation period. The frequency-domain information symbols will be recovered by the waveform contained by the observation period.

Mapping and Demapping:

The transferred stream of data is transformed and bunched together in a parallel data streams; each one mapped on corresponding information symbols using different and complex modulation format (M-QAM or QPSK) in lieu of the subcarriers in singular OFDM symbol.

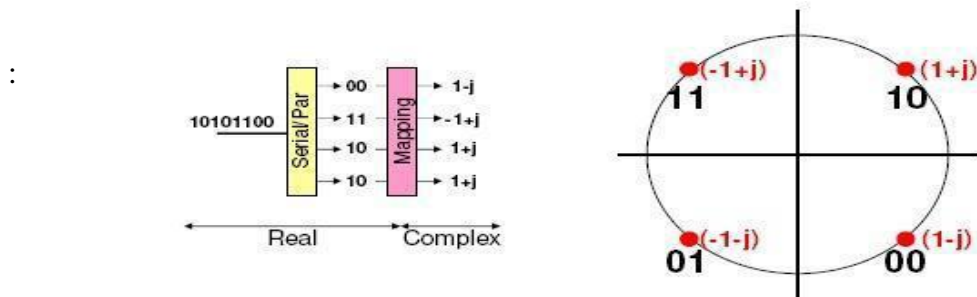

Figure 1.11: 4-QAM mapping.

In the case of 4-QAM modulation format as shown in the Fig. 1.11, the serial data which is applied at the receiving side practices twofold bits to craft each solitary of the four probable complex-valued QAM symbol. At the receiving end, corresponding demapping of the every complex-valued symbol is taking place and the resulting symbol sequence is sequentially acquired to the actual bit stream. On the other hand the resulting records is not transmitted by some means of an ideal channel, so before the demapping of the symbols a decision must be

taken so that every constellation point has to be projected. This method is known as slicing shown in Fig. 1.12.

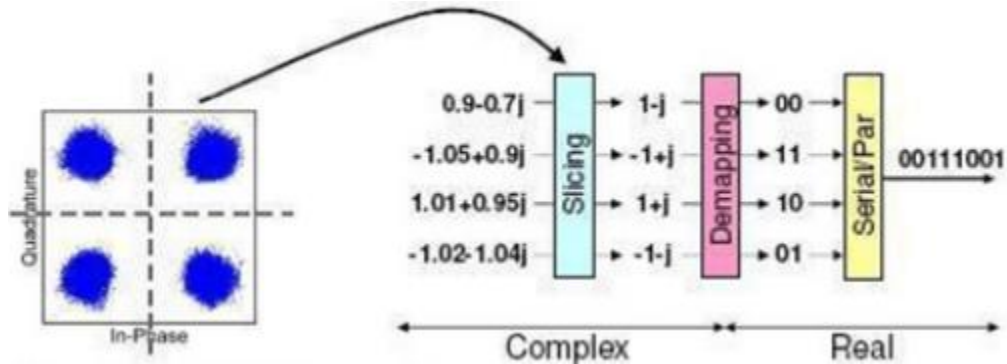

Figure 1.12: 4-QAM demapping and slicing.

1.12 OPTICAL OFDM (O-OFDM):

In spite of using OFDM in wireless communications, it is being extensively used in the optical communication systems recently. Lately OFDM has acknowledged a lot of interest in the fiber-optics community. The foremost beneficiary of the O-OFDM happens to be that it has the ability to deal with practically unlimited magnitude of ISI. ISI is triggered by CD and PMD in high-speed optical systems [32].

Table 1.1: comparisons between Wireless OFDM and O-OFDM

Parameters	Optical OFDM (O-OFDM)	Wireless OFDM
Mathematical Model	Continuous frequency Domain	Multiple discrete time Domain
Speed	Average	Fast for mobile environment
Non Linearity	Important, Significant	None
Information supported	On optical strength	On electrical field
Local oscillator	At mouthpiece	At receiver
Polarity	Unipolar	Bipolar

1.12.1 Optical Channel: Chromatic Dispersion

Chromatic dispersion (CD) happens to belong in the category of distortion due to the designing in some optical fiber. It results from frequency dependence on the proportion by which the phase of the wave transmits in area (optical phase velocity) and its effectiveness on the conveyed optical signal mostly scales quadratic ally through the information rate.

The frequency dependence of the phase pointed out could be simply known by a pulse that transmits over a single mode fiber into the frequency domain [37].

$$X_{out}(\omega) = X_{in}(\omega) e^{-j\beta(\omega)z} \quad (1.12)$$

where $X_{in}(\omega)$ resembles to the Fourier Transform of the signal transmitted and at the receiver $X_{out}(\omega)$ corresponds to the Fourier Transform of the signal recovered and $\beta(\omega)$ represents the phase constant of propagating mode.

Because of frequency dependence of phase on β , the major obstructive effect measured in equation (1.12) is due to the C.D. Other phenomenon as nonlinearities or attenuation will not be measured, although their properties are going to be considered later. The phase constant $e^{-j\beta(\omega)z}$ is linearly dependent with frequency, in an ideal case. This means that each and every spectral component propagates with the identical velocity and thus experiences the identical phase delay. The signal is going to be received with a constant delay but deprived of any distortion. But, the phase constant $e^{-j\beta(\omega)z}$ which is nonlinearly reliant on frequency, in a dispersive channel. This results in separate arrival time of these frequency components; its significance is that at the reception end, the recovered signal would not be the same with respect to the transmitted signal.

1.12.2 Optical Modulation Techniques:

For transmission of the electrical signal through the optical SMF channel, typographies of optical modulation which are as follows first Mach-Zehnder modulator (MZM): the IQ MZM and second the “standard” mode, and a directly modulated laser.

1) Intensity Modulation/ Direct Detection (Directly Modulated Laser):

In this technique, an electrical signal by using its bias current, modulation is directly happens in the laser diode. Fig. 1.13 shows the characteristic graph of the laser diode, which shows a

linearly behavioral region. The slope of this linear region is termed as the slope efficiency.

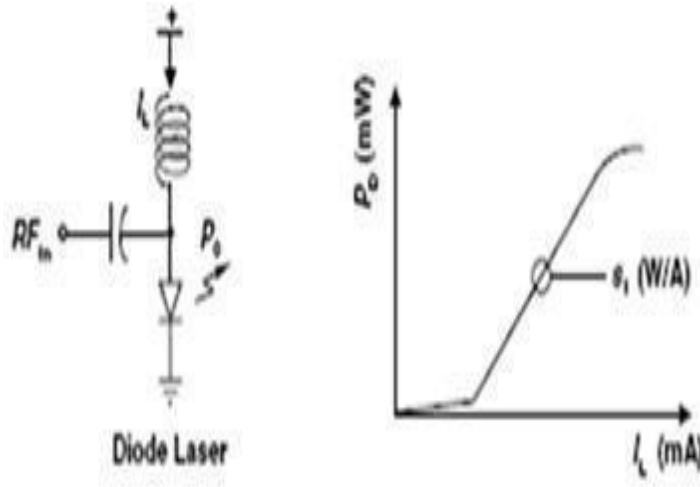

Figure 1.13: Schematic and typical curve of laser diode

In addition to this, the schematically diode laser is also shown in Fig. 1.13, where it refers the optical power and bias current, respectively. This is principally the most common way to transmit information via fiber (optical fiber), based upon the bias current deviations of the laser diode beyond a certain threshold. These bias current variations (I_m) are accountable for the proportional output optical power deviations, which can be detected at the receiver end of the PIN diode, which carries the reverse process and sent information signal is recovered as:

$$P_{out} = P_o (1 + m *s (t)) \quad (1.13)$$

Where $s (t)$ is information signal, m is modulation index and P_o is power associated to laser bias, m is I_m/I_o . The total received intensity is given by:

$$I_R(t) = RGP_o(1+m.s (t)) \quad (1.14)$$

where R is responsivity of PIN diode, $I(t)$ is the total received intensity and G is various gains Fig. 1.14 shows that some electrical signal $s (t)$ which is renovated into an optical carrier. After the juncture of emission, these electrical signals is changed into its equivalent optical signal (E/O) and at the receiving corner vice versa i.e. (O/E) takes place. This type of transmission is called Intensity Modulation / Direct Detection (IM/DD).

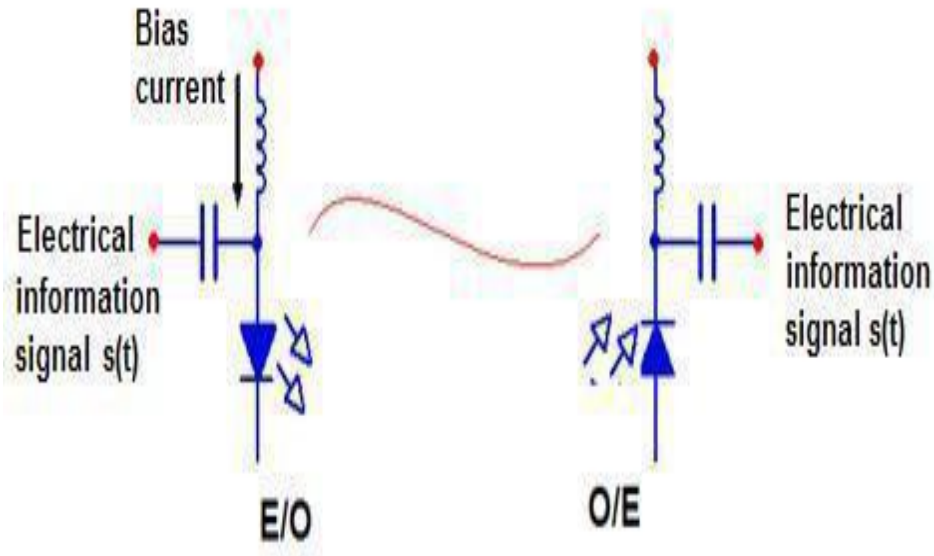

Figure 1.14: Schematic Intensity Modulation and Direct Detection.

2) Standard Mach- Zehnder Modulator (MZM):

The direct modulation (IM/DD) is an economical and it is easily adaptable for low cost applications for adequate transmission rates and moderate distances. On the other hand, for applications associated with respect to extended distance links or higher information rates, external modulation is used in many different cases.

The extensively used external modulator in optical communication is Mach-Zehnder modulator (MZM) that modulates the light produced with the help of a laser source which is operating in continuous wave (C.W) mode. The MZM generally has a DC bias input and an RF input, as shown in Fig 1.15. The optical power at the MZM output depends upon the difference because of the phase of the two supports of the modulator (MZM) that ought to be altered by fluctuating the bias of the modulator (MZM) [35]:

$$P_{out} = P_{in}(t).d(t) = P_{in}(t).cos^2[\Delta\Phi(t)] \quad (1.15)$$

$$\Delta\Phi(t) = \frac{\Delta\varphi_2(t) - \Delta\varphi_1(t)}{2} \quad (1.16)$$

Where $d(t)$ shows power transfer function of MZM and $\Delta\varphi_1(t)$ and $\Delta\varphi_2(t)$ are the phase deviations happens in each branch of the MZM.

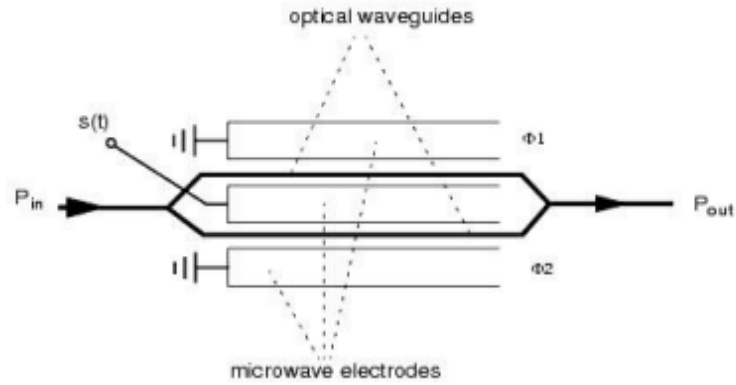

Figure 1.15: Mach-Zehnder modulator (MZM)

3) IQ Mach-Zehnder Modulator:

The IQ Mach-Zehnder modulator (MZM) predominantly consists of two null-biased Mach-Zehnder modulators (MZM). The phase alteration amongst them as given away in Fig. 1.16, with one RF input for each one section of the OFDM signal (I and Q). The electrical domain envelope using the modulated signal in optical domain is relative to the statistics signal when

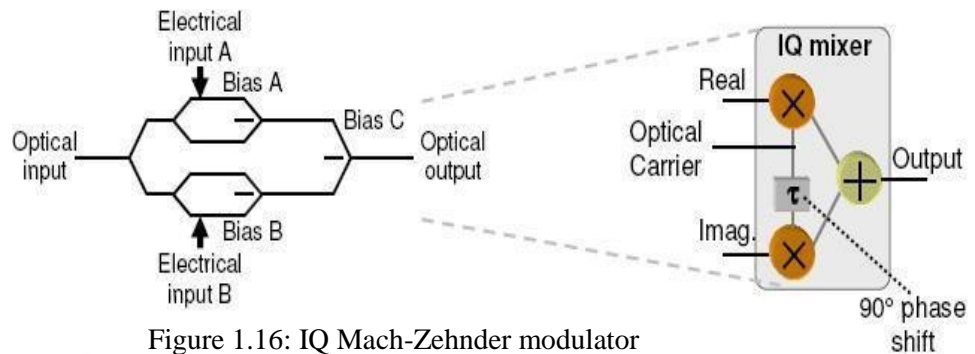

Figure 1.16: IQ Mach-Zehnder modulator

IQ-MZ modulator, so that its bias null-point is tapped. The key shortcoming of IQ-MZ modulators (MZM). The phase alteration amongst them as given away in Fig. 1.16, with one RF input for each one section of the OFDM signal (I and Q). The electrical domain envelope using the modulated signal in optical domain is relative to the statistics signal when IQ-MZ modulator, so that its bias null-point is tapped. The key shortcoming of IQ-MZ modulation is that it consists of three bias voltages which are required to be correctly adjusted.

The problems associated with the double sideband spectrums is that can be removed for some complex OFDM signal which consequences in single optical sideband.

1.12.3 Varieties of Optical OFDM (O-OFDM) Detection:

The twofold well-known classifications of optical OFDM are Coherent detection and Direct detection. In previous periods direct detection is extensively used in optical communication system, although the most recent boom in this subject matter has particularly bring out the trend that this coherent detection technique will be the forthcoming method in the field of optical communication.

Direct detection

DDO-OFDM when compared to CO-OFDM has a major difference in their working. Direct-detection OFDM is appropriate for economical, short or moderate distance application. Some well-known peculiarity for DDO-OFDM is that the detection is done directed towards the receiver end. By going the through the generation of optical OFDM signal, DDO-OFDM is cataloged into two groupings: (1) linearly mapped DDO-OFDM (LM-DDO-OFDM), in which the optical OFDM spectrum exhibits an imitation of baseband OFDM (2) non-linearity mapped DDO-OFDM (NLM-DDO-OFDM), through which the optical OFDM spectrum becomes a real baseband OFDM [33].

Coherent detection

CO-OFDM has the extreme complexity while designing the transceiver but also has the dynamic enactment in proficiency of the spectrum, sensitivity at the receiver, and stoutness alongside polarization dispersion. The elementary norm of CO-OFDM will be the accomplishment of high spectral efficiency along with coinciding subcarrier spectrum evading the interference while using the signal arrangement orthogonality property and coherent detection. Greater enactment of CO-OFDM sorts out a more resourceful technique for long haul transmissions. In CO-OFDM systems, the local oscillator is used, as the optical carrier is produced in the vicinity of laser source. Henceforward lower communicated power i.e. optical power is necessary is used via CO-OFDM in contrast with DDO-OFDM, even though it is highly sensitive to the phase noise. The leading benefit of OFDM when integrated with coherent optical transmission are as follows: first it has higher spectral and computational efficiency, second is that CO-OFDM is robust against polarization mode dispersion and third is that CO-OFDM compromises great receiver sensitivity, fourth is that lesser extent of DSP complexity and a concentrated amount

of oversampling factor.

1.12.4 Coherent optical OFDM (CO-OFDM) system:

The abstract figure of a CO-OFDM is given away in Fig. 1.17. It consists of five fundamental well-designed blocks:

1. RF-OFDM signal transmitter,
2. RF to optical (RTO) up converter,
3. Optical fiber links,
4. optical to RF (OTR) down converter,
5. RF-OFDM receiver.

Next to RF OFDM source part, the information queues are distributed along numerous parallel stems, this procedure is labelled as “serial-to-parallel” (S/P) adaptation. The various subcarriers frequencies which are allotted to these symbols will be in exact equivalent of the subdivisions performed in the previous procedure. So the corresponding transformed signal is plotted onto altered modulation layouts, such as QAM, PSK etc. The recorded signal which is in frequency domain is altered by the IFFT block kept on its equivalent time domain.

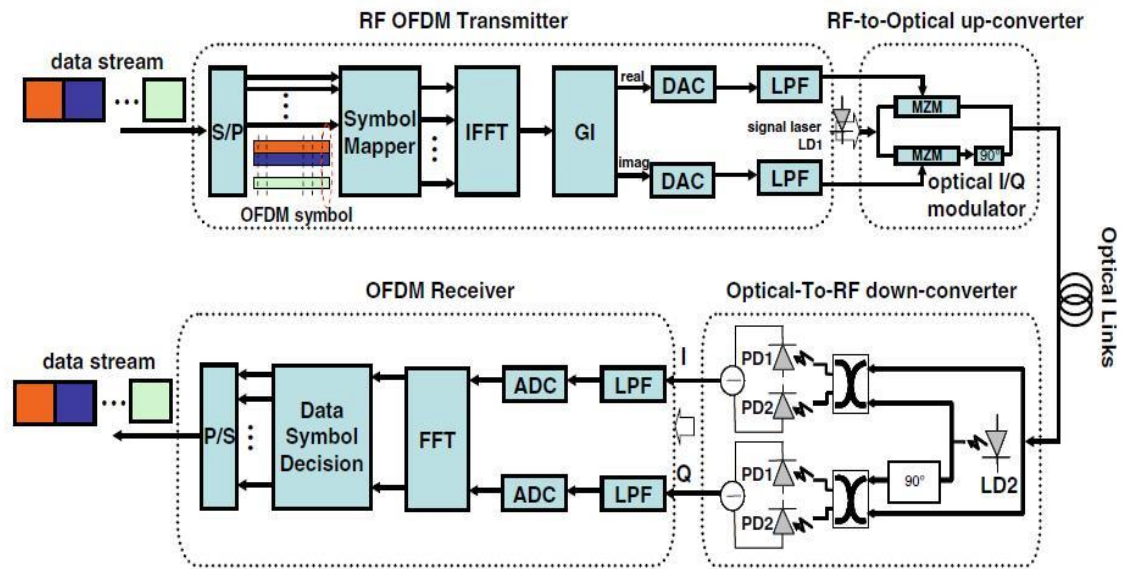

Figure 1.17: Block diagram of a coherent optical OFDM (CO-OFDM) system.

This information has to be in two-dimensional complex pattern. The enclosure of cyclic prefix is performed to eradicate channel dispersal (ISI, ICI). Inside the RF to optical (RTO) upconverter block, the baseband OFDM signal $S_B(t)$ is now gets modified into optical domain

by the measures of an optical I/Q modulator that encompasses of two MZM alongside we utilized optical phase shifter having the value 90° . The up-converted OFDM signal within its optical domain is represented by [43]:

$$E(t) = e^{(j\omega_{LD1} + \varphi_{LD1})} S_B(t) \quad (1.17)$$

Where the φ_{LD1} is the phase and ω_{LD1} is the frequency of the laser at the transmitter.

The optical signal $E(t)$ with is delivered over the network whose impulse response is $h(t)$ into the fiber link. The received optical signal comes to be [43]:

$$E'(t) = e^{(j\omega_{LD1} + \varphi_{LD1})} S_B(t) \odot h(t) \quad (1.18)$$

In this case, \odot denotes the convolution operation.

Towards the OTR down converter column, the optical signal $E'(t)$ is acknowledged and is assorted through the localized laser supply whose phase is φ_{LD1} and occurrence is ω_{LD1} .

Assuming that if there is frequency dissimilarity or phase alteration occurs amongst the transmitter and receiver source of lasers and then they are prearranged by [45]:

$$\Delta\phi = \varphi_{LD1} - \varphi_{LD2} \quad (1.19)$$

$$\Delta\omega = \omega_{LD1} - \omega_{LD2} \quad (1.20)$$

Then the received RF-OFDM signal is written as

$$r(t) = e^{(j\omega_{LD1} + \varphi_{LD1})} \odot h(t) \quad (1.21)$$

1.13 ADVANTAGES & DISADVANTAGES OF O-OFDM:

OFDM devours numerous repayments and some of the advantages are shown below:

An enormous volume of data can be transmitted and at receiver end an easier equalizing technique is used to detect that data.

1. Due to Robust nature of the signal against ISI, ICI, CD throughout the passage. The use of cyclic prefix is required to nullify ICI and ISI.
2. Optical OFDM, without the use of complex equalization can easily be adjusted to severe channel conditions.
3. Inferior errors due to sensitivity to time synchronization.
4. Power overloading and dynamic bit capability is good.

5. Simplicity in dynamic channel estimation.
6. Extra resistance to selective fading and multipath fading.
7. Larger bandwidth (spectral) efficacy, subsequent carrier are concentrated, subcarriers in O-OFDM are being orthogonal to each other and overlays. Henceforth outcomes in great spectral efficiency as made known in Fig. 1.19.

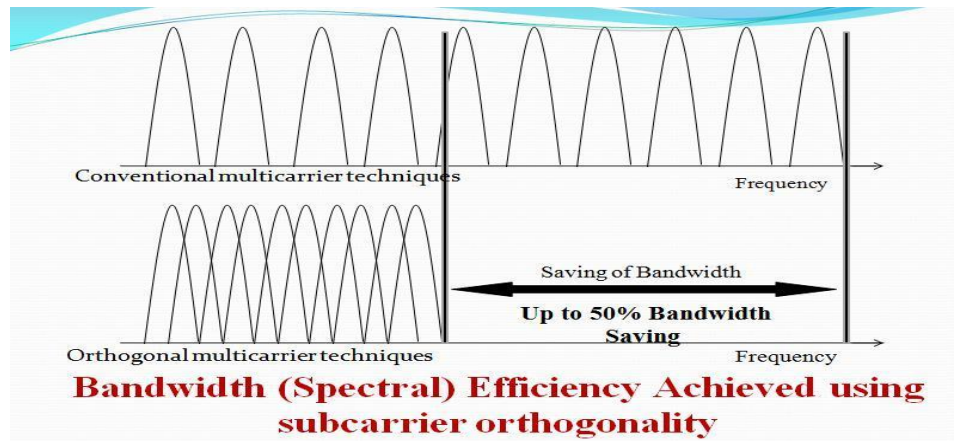

Figure 1.18 High bandwidth efficiency achieved due to orthogonal subcarriers.

8. Tolerance towards linear impairments –Comparing with coherent detection QPSK, OFDM can easily be reimburse with linear deficiencies present with electrical field, which facilitates a tolerance upto to a great extent for PMD and network dispersion.
9. Oversampling – According to the Nyquist criterion, the Nyquist frequency of the signal is 5 GHz and sampler proportion of some AWG rounds 10 GHz. In this case, Oversampling is understood by only modulating 190 subcarriers out of the 256 subcarriers. Oversampling factors of 1.34 will be comprehended due to the 66 unmodulated subcarriers. Oversampling causes ~2.5 GHz spectral gap which is present in amongst the aliasing products and the OFDM signal. A low pass filter could be able to use and eliminate these aliasing products.

1.13.1 DISADVANTAGES OF OFDM:

OFDM compromises of several hindrances. Here are some shortcomings of OFDM, which uses this phenomenon of multicarrier modulation (MCM) technique which adds on top complication when it is compared with other single-carrier modulation techniques and alongside there's more linear power amplifier requirement in OFDM.

1. Peak to Average Power Ratio (PAPR):

Out of many downsides throughout the OFDM modulation arrangement is high peak to average power ratio (PAPR). An OFDM signal is produced by accumulating a number of independent subcarriers. This may result into a severe drawback called the high PAPR if all the subcarriers be situated coherently, shown in Fig. 1.19, huge peak at time interval $t=0.23$ sec.

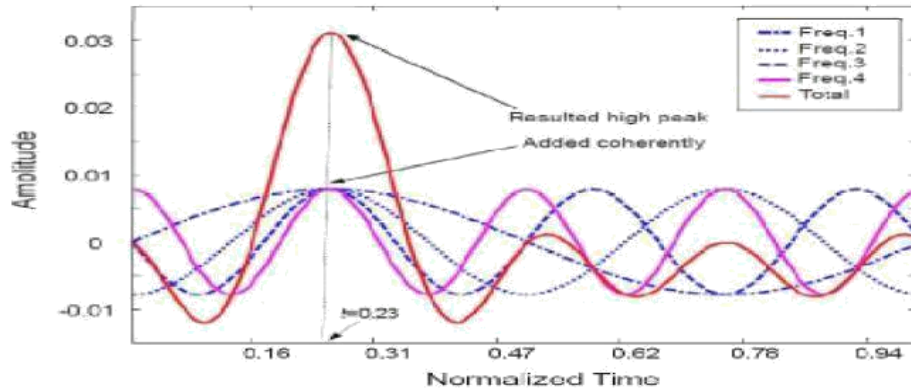

Figure 1.19: High peak on OFDM system

2. Frequency Offset Sensitivity and Phase Noise:

The second major shortcomings during OFDM ought to be phase noise which principally results into ICI and frequency offset because of its lengthy character span when we keep comparing it to that of other single carrier modulation techniques. Frequency offset sensitivity can be eradicated completely by frequency compensation and estimation [31].

3. Time offset error:

The brand of error is initiated because of the erroneous recognition of the OFDM symbol boundary at the receiver end, while it takes along in ISI and ICI. The accumulation of the cyclic prefix (CP) makes OFDM considerably extra robustness towards time offset errors. The time offset may rise and fall over an interim which is equivalent to the CP length without causing ISI or ICI.

1.14 OBJECTIVE OF DISSERTATION:

Based on initial studies, literature survey and the understanding established the following objectives are proposed.

1. To study multiplexing techniques in optical sensor and Orthogonal Frequency Division Technique.
2. To design a full duplex wavelength division multiplexed hybrid sensor for different applications
3. To use coherent detection and study its effect on Coherent Optical Orthogonal Frequency Division Multiplexing in Optical communication system

1.15 ORGANIZATION OF DISSERTATION:

This dissertation starts with basic introduction of WDM, Optical Sensors, FBG, PCF, and basis theory about OFDM and its mathematical analysis, applications are discussed. After that objectives are framed and discussed.

Chapter 2 has taken explanation of the literature survey pertaining around the focus of the dissertation. In authority to initiate this dissertation, the initial period is to schoolwork the papers allied with the work which has been in the past published by researchers. Literature review gives the assistances to complete this work.

Chapter 3 presents a design a full duplex wavelength division multiplexed hybrid sensor and for different applications.

Chapter 4 represents the use of coherent detection and its effect on Coherent Optical Orthogonal Frequency Division Multiplexing in optical communication system. The effect of various subcarriers is investigated on coherent optical orthogonal frequency division multiplexing (CO-OFDM) using Dual Polarization Quadrature Phase Shifting Keying (DP-QPSK) modulation technique.

Chapter 5 includes the Conclusion, Recommendation and Future Prospect of the work.

CHAPTER 2

LITERATURE SURVEY

The literature survey on PCF and FBG optical OFDM systems by various researchers in past years is shown below:

G. Badenes *et al.* [15] verified that a strain sensor which was established on a large-mode-area PCF. Tapering of these fibers was done in order to permit collapsing of air holes. This process made these fibers extra sensitive towards many environmental parameters. Also, it triggered an alteration of the taper waist into a solid multimode fiber by introducing the coupling concerning various generated modes of the fiber. Consequently, a sequence of interference peak was detected in the transmission spectrum of the sensor device. The device unveiled temperature insensitivity, meantime no swing in the spectrum was witnessed when temperature settings starting at 0°C and ends at 180°C. The narrated sensor was competent to function at a number of wavelengths and was reversible in nature.

V. Finazzi *et al.* [16] informed that the strain sensing assisted by a PCF linked with two standard OFs. The air holes of the PCF were collapsed over a short section to convert it into a solid all-silica fiber, which caused in lengthening of propagating modes of the lead-in fiber, successively permitting intermodal coupling only in the middle of two modes in the fiber. The testified sensor sensitivities of 2.80 pm/ $\mu\epsilon$ at 1550 nm and 1.45 pm/ $\mu\epsilon$ at 850 nm were relatively higher than that which they attained through Bragg grating-based strain sensors. A small error of $\sim 1.5 \mu\epsilon/^\circ\text{C}$ in strain dimension was met because of temperature instabilities. Thus, for customary environment circumstance, the sensor required no necessity of temperature compensation. The device indicated that how attractive traits like wavelength-encoded information, entirely linear reaction, over an all-embracing series of wavelengths, highly insensitive towards temperature, and uncomplicated fabrication. The suggested scheme was beneficial in numerous applications where physical factors like vibration, load etc. could be converted into the dimensions of strain changes.

J. L. Santos *et al.* [17] work out on the development of Hi-Bi PCF-based strain sensors with great thermal insensitivity. Measurement regarding wavelength was utilized to sense the deviations in strain. The Hi-Bi PCF loop mirror was investigated for two diverse cases: uncoated and acrylate-coated PCF. It was witnessed that layering the PCF aids in trivial increment of the

strain sensitivity ($1.21 \text{ pm}/\mu\epsilon$) while comparing it with that achieved with the uncoated one ($1.11 \text{ pm}/\mu\epsilon$). This device was testified as insensitive towards the temperature deviations and a little sensitivity of $0.29 \text{ pm}/\text{K}$.

Q. Shi *et al.* [18] calculated the strain sensor that was insensitive towards the temperature and curvature. This style of strain sensing was realized with some assistance from miniature in-line Fabry-Perot interferometers from end to end splicing of a minor portion of HC-PCF amid two SMFs. The light is guided towards the air while using the HC-PCF, the temperature-induced variations in strain were small, unsettled towards the zero thermo-optic coefficient of air. Also, lesser dimension of PCF was involved which made it challenging to bend the fiber, to witness insignificant spectrum alteration of the reflected signal due to bending. The anticipated proposal was able to attain high strain sensitivity of $1.55 \text{ pm}/\mu\epsilon$ and was exceedingly stable towards innumerable external deviations.

Y.G. Han [19] suggested strain measurement based on a PM-PCF. He was able to achieve periodic communication (wavelength dependent) in a birefringent interferometer by employing a section of PM-PCF in the middle of two linear polarizer. Since, very minute change in the birefringence of PM-PCF was witnessed when temperature was altered, negligible shift was detected in the peak wavelength of the spectrum. It results in a low sensitivity of $-0.3 \text{ pm}/^\circ\text{C}$ with temperature. Nonetheless, a proportionate shift in peak wavelength was witnessed on longitudinal strain of the device. A strain range of 0 to $1600\mu\epsilon$ calculated in a high strain sensitivity of $1.3 \text{ pm}/\mu\epsilon$ with an expected resolution of $2.1 \mu\epsilon$. This clean structure included values like unproblematic installation, and little loss when the system is devoided of a Sagnac loop and much insignificant sensing probe.

W. Qian *et al.* [20] elaborated an economical temperature-insensitive strain sensor based on Hi-Bi PCF loop mirror. Intensity-based dimension was utilized to achieve a low temperature sensitivity of $0.0027 \text{ dB}/\mu\epsilon$ meanwhile the locus of resonant dip was slightly affected by the deviations in temperature. Nevertheless, linear shifting during the resonant dip towards extended wavelengths was witnessed with the elongating of the fiber, as phase matching circumstance fluctuations due to applied strain. An optical power meter was found satisfactory to calculate changes through output intensity of FLM with submission of strain, thus abolishing the necessity of an OSA, which will make this design more economical.

A. J. Lowery *et al.* [23] described the feasibility of the architecture to which represented an

arrangement of OFDM along with optical single sideband modulation which compensates the chromatic dispersion in WDM systems. These authors used numerical simulations, to study the effects of fiber dispersion, WDM network and arrangement, and input power for every frequency on the acknowledged Q and summarized these effects for the set of design rules.

M. S. Moreolo *et al.* [24] studied that the O-OFDM is among one of the most encouraging technique used in planning schemes which cause higher moment rate furthermore for bandwidth adaptable transponders as crucial enablers for lithe, adaptable, and spectral efficient networks. The writers unfilled an economical O-OFDM system with flexible bit rate using less complex DSP having PAPR lessening properties. O-OFDM with the help of coherent detection and phase modulation was also suggested as a suitable spectral competent manner, in optical communication networks.

Y. Benlachtar *et al.* [34] investigated the use of OFDM to augment the aptitude of MMF constructed optical networks. The authors presented a resolution for intermodal dispersion in the MMF. They studied the modulation bandwidth drawbacks of the lasers which are responsible for frequency-dependent attenuation. Adaptively modulated OFDM was studied, and new results using different simulations was offered for measuring the aptitude of these linkages for lengths equivalent to 300 m, taking graded-index MMF at 850 nm wavelength.

B. Pirom *et al.* [35] mathematically analyzed the phase distortion of O-OFDM signal due to Kerr effect and different fiber dispersion. The results were confirmed using OptiSystem 5.0 software and were matched with the mathematical results.

H. Chen *et al.* [36] projected a PAPR reduction procedure for 16-QAM OFDM structures and BPSK OFDM structures. Many algorithms were calculated to use the scrambling subcode to control or lessening of PAPR and a correction subcode to control error. The authors attained PAPR reduction in a BPSK OFDM network by merging the SLM routine with the binary cyclic codes, and also accomplished the PAPR reduction in a 16-QAM OFDM network, by amalgamating the SLM with the block coded modulation. The signal received of the modified SLM able to be decoded without the requirement of explicit side information.

L. Liu *et al.* [37] recommended a novel tactic for reimbursing CD besides accustomed phase/amplitude to make usage of trial tones in optical OFDM conduction. Though different approach brands usage of the chromatic scattering fiber assets while consuming less trial tones. The recreations revealed a foremost progress in bit error rate forfeit in the optical OFDM sign,

equated with different solo orientation mark procedures and the predictable least-square (LS) linear interpolation procedures.

H. Louchet *et al.* [38] projected an innovative architecture on the basis of optical heterodyne detection and some OFDM modulation techniques which requires no optical or electrical phase-locked-loop (PLL). The authors paralleled the network performances with the data-rate of 100-Gb/s using DQPSK system.

J. Pan et al [39] verified the nonlinear electrical equalizer which is based upon the Volterra model, which is able to compensate fiber nonlinear distortion in various PSK or OOK optical communication networks. Though, the Volterra model has been based on electrical equalizer's implementation but the complexity issues help us to make less use in CO-OFDM system. The authors further validated that the numerous kernels going to be used in the Volterra model which is built on making the use of electrical equalizer to reduce the complexity by using the adapted Gram-Schmidt method which uses reorthogonalization procedures. The operation of the electrical equalizer which is based on "full" Volterra model is now comparable with respect to the electrical equalizer which is based on "scarce" Volterra model.

C.H. Cheng [40] confirmed that together equalizers and pre distorters are used in the compensation of nonlinear distortion of the CO-OFDM system. The authors explored the presentation between the electrical pth-order verses Volterra equalizers and then that of predistorters, making the use of CO-OFDM system and treating it like a test system. The chief difference that arises amongst the equalizer and the pre distorter is that the latter is used to normalize power of the optical input; henceforth, the implementation of coherent optical OFDM (CO-OFDM) system while using some predistorter is autonomous with the wide range of source laser launch power.

G. Zhanget *et al.* [41] promoted that optical orthogonal frequency division(OOFDM) technique, based on new adaptable optical network design, with scalability in spectrum distribution and colossal flexibility and information amount lodgings may possibly be built to sustenance numerous amenities and sudden increment in Internet traffic growth. These authors presented a wide-ranging appraisal on OOFDM technologies, including the critical principles of OFDM, organized with O-OFDM machineries, along with the assemblies of OFDM which is widely established on the variable core optical networks.

S. Hussin *et al.* [42] explored the functioning of different OFDM techniques like coherent

optical OFDM (CO-OFDM), direct detection optical OFDM (DDO-OFDM), and self-coherent optical OFDM (SCO-OFDM). The authors first reread the academic basics of O-OFDM and the dissimilarities surrounding the three techniques (CO-OFDM, DDO-OFDM, SCO-OFDM) and later, the comparison is done among these different OFDM.

H. Bao *et al.*[43] executed the theoretical foundation for the coherent optical OFDM (CO OFDM) networks for the direct down/up conversion architecture. The authors further make evident that the system performance throughout the simulation of WDM structures alongside CO-OFDM which includes the outcome requires nonlinearity of the fiber. The outcomes exhibited that the Q system of WDM channels for 10 Gbps over 13 dB used through the communication distance of 4800 km acquiring SSMF lacking compensation of dispersion. The authors also give away that the partial carrier filling (PCF) technique is used to amend the non-linearity recital. The Q system of the WDM channels for 10 Gbps using a filling factor of around 50 % exhibited enhanced results from 15.1 dB to 16.8 dB for a communication distance of around 3200 km of SSMF with nil dispersion compensation.

W.H.Chen *et al.* [44] presented some closed-form study to envisage MZM-induced combined triple beat (CTB), in tallying to composite second-order (CSO) and distortions happening due to the reason of CTB in order to apprehend the inadequacy of (SSB/SCM) signals using single mode fiber. Numerical and analytical tools that are not forced by any modulation frequencies and wavelength graphics were used to examine cross-phase modulation-induced crosstalk. The authors also studied that the number of multichannel SCM/SSB/DWDM systems with 10 or 20 Gb/s per wavelength transport capacity, with 25, 50, and 100 GHz, wavelength spacing to realize the shortcomings of this arrangement.

I. K. Mizrahi *et al.* [45] proposed an economical approach of optical OFDM (O-OFDM) system which is based on adaptive direct modulation SOA (semiconductor optical amplifier) which has the huge prospective among the peers working on an inert optical complexes and Ethernet PON, because of its higher spectral efficiency as well as greater flexibility in bandwidth employment. The instigators scrutinized the adaptive current loading practices for PAPR reduction. Simulations displayed that the BER improvement in the projected adaptive techniques.

Table 2.1 Literature survey

Type	Authors	Work Done	Results
PAPR reduction	Michela Svaluto Moreolo <i>et al.</i> [24]	A cost-effective O-OFDM system with variable bit rate using less complexity DSP with PAPR reduction.	Spectral efficient way, robust against Non linearities.
PAPR reduction	H. Chen <i>et al.</i> [36]	PAPR reduction technique for 16-QAM OFDM by combining the SLM with block coded modulation and also for BPSK OFDM by combining the SLM with binary cyclic codes.	The algorithms were designed to use a scrambling subcode for controlling PAPR and a correction subcode for controlling error.
PAPR reduction	Pooria Varahram <i>et al.</i> [47]	Presented a small complexity PTS scheme, for reducing the PAPR in OFDM systems along with a new phase sequence.	Results were examined with QPSK modulation, and power amplifier and OFDM signal with memory effects.
PAPR reduction	Jair A. L. Silva <i>et al.</i> [48]	PAPR reduction method based on constant envelope OFDM approach using 2.66 GHz signal bandwidth, 16-QAM, in order to reduce induced fiber nonlinearities in the direct detection OOFDM systems.	The proposed system outperforms DDO-OFDM system. BER of the proposed scheme was decreased by a factor of 1000 when compared with conventional DDO-OFDM system.

PCF	Y.G. Han	Use of PM-PCF to observe change in birefringence with strain and temperature	Increase in strain sensitivity and resolution and reported low losses without Sagnac Loop
Hi-Bi PCF.	W. Qian <i>et al.</i>	Use of intensity based-interrogation for strain sensor based on Hi-Bi PCF loop mirror	Low temperature sensitivity and eliminated need of OSA to make design cost effective
FLRD	W. Zhou <i>et al.</i>	Combined PCF-MZI with FLRD technique to obtain high strain sensitivity and Resolution	High detection speed for utilization in instrumentation Field
PCF	L.M. Hu <i>et al.</i>	Experimentally demonstrated temperature insensitive strain sensor based on modified PCF-MZI	High temperature stability and higher sensitivity to strain
Hybrid Sensor	W. Peng <i>et al.</i>	Proposed a hybrid sensor structure combining MC-FPI with MZI to be operated in both transmission and reflection modes	Improved strain sensitivity and polarization independency

DESIGN OF A FULL DUPLEX WDM HYBRID SENSOR FOR DIFFERENT APPLICATION

In this chapter, the effect of optical hybrid sensor based on wavelength division multiplexed technique (WDM) is studied using Photonics crystal fiber and Fiber Bragg Grating (FBG). Full Duplex scheme is used in this system to receive and transmit the data at same time for fast processing. The Finite difference time domain photonics simulation software (FDTD) is helpful in observing the variation in reflection and the transmission power spectra of the photonic gratings. Using line defects we created two linear waveguide, further it is used as optical sensor. From this work we recommend that the proposed system can be used as in communication filed for data transmission and also used in sensing application to sense the property and deformation of object.

3.1 Introduction

The maturity in optical fiber sensor and its impact on various domains of engineering is very evident. It possesses a good tolerance towards electromagnetic interference and has numerous advantages like compactness, high sensitivity, easily accessible while dealing with multiplexed sensors system [51]. An optical sensor provides a collective technological base to sense temperature, pressure and strain measurands perturbations [52]. Because optical sensors are able to provide an advanced technology, that's the reason behind its immense commercial use. The optical sensors have received wide appreciation and flourished in various technical domains like optical fiber communication, civil engineering, aerospace and aircraft industry, nuclear technology, petrochemical and coal mining [53]. Optical sensors uncovered several applications in chemical and biological sensing and optical nanosensors. Magnetic, gyro, photoacoustic, current, pressure, acoustic, temperature, torque, displacement, acceleration, fluid level, and strain sensors is different fiber optic sensor types which are currently in severe examination [54]. Optical sensors are applicable in several spectroscopic patterns (fluorescence, scattering etc) and signal processing procedures including fuzzy logics, pattern recognition algorithms and artificial

neural networks. Optical nanosensors deals with intracellular measurements and consistent in scrutinizing chemicals and biochemicals like DNA molecule, carbon dioxide, oxygen etc and when connected to a thermocouple helpful in temperature calculation [55]. Researchers' has integrated IC's, fibre optics and micro electro-mechanical systems (MEMS) which lead to the amalgamation of information technology, biotechnology and nanotechnology resulting in compact, lightweight, highly sensitive and precision in optical sensor designs [56]. Free space optics (FSO) sensor system is beneficial in underwater sensing [57]. W. Kunzler et al. [58] described various conventions that is being used to translate any optical domain to a sensor subsystem, then integrated system test data acquired from sensors in dynamic temperature and strain environments. H. Zhiqi et al. [59] proposed a selection method, which commendably diminishes the noise impact of digital signal processing procedures. Different benefits of this method are cost effective, adaptive to changes, possess flexibility. It was reported that, zero-phase filter gives accurate performance, followed by median filtering and five-point cubic spline method. G. Palai et al. [60] investigated the various optical characteristics like dispersion and confinement loss in chalcogenide hexagonal photonic crystal fiber (PCF). In the suggested system, they analyzed that the effective mode index improves with augmenting air holes quantity and electric field distribution is focused just over-head the center, when there is an increase in the quantity of air hole ring is. Later they commented on the confinement loss, as it increases with an increment in pitch and diameter of the core. Y. F. Li et al. [61] studied a fully vectorial effective index scheme for the computation of dispersion in photonic crystal fiber. Later they conveyed that, by optimization the parameters of the fiber, the accuracy of results which they got by the vectorial effective index method than the scalar method

In this chapter, we have proposed hybrid optical sensor based on photonics crystal for different application. In civil engineering, optical sensors are used for strain calculation of structures. Utilizing optical sensors, early recognition of erosion of tunnels, buildings and bridges can be estimated, so that the maintenance costs are moderated. In transportation, optical sensors provide electrical insulation in railway contact lines, pantographs due to low electromagnetic interference. In aeronautical and aerospace industry, optical sensors are exploited for estimating strain and temperature in fuselage and main wing structure of aircrafts. For surveillance of temperature in array antenna RF testing, satellite structure,

and electric propulsion subsystem. In geo-technical domain, such as gas exploration and coal mining. In biomedical procedures, fiber-optic sensors is helpful in observing intracranial and intracardiac pressure [62].After introduction, the chapter is sorted out as followed: In section 3.2, mathematical analysis of the proposed scheme is discussed. In section 3.3, simulation set up of the proposed system is portrayed. In section 3.4, results are discussed and conclusion is drawn in section 3.5.

3.2 Mathematical Analysis

The gratings are achieved by crafting a wavelength-specific dielectric mirror upon the fiber core and consists of periodic sections of high and low refractive indices. Whenever the grating is exposed with a broad-spectrum light, some of its energy is transmitted and the other part is reflected. This periodic grating works like a filter, reflecting only a narrow wavelength range which is identified as the Bragg wavelength λ_B (Eq. 1). FBG can be used as a wavelength-specific reflector permitting certain wavelengths except one which fulfills Bragg law [63]

$$\lambda_B = 2 * n_{\text{eff}} * \Lambda \quad (3.1)$$

Where Λ signifies period of grating, λ_B indicates the reflected wavelength and $n_{\text{eff}} = 1.46$ mm characterizes actual group refractive index of the fiber core's.

In depressive media, finite difference time domain (FDTD) method is extensively exploited during the assessment of electromagnetic field. While operating on time domain, the wave propagation through the PCF layout is established by direct integration of Maxwell's equations [64]

$$\nabla \times H(r, t) - \epsilon(r) \frac{\partial(\epsilon_0 E(r, t))}{\partial t} = 0 \quad (3.2)$$

$$\nabla \times E(r, t) + \frac{\partial(\mu_0 H(r, t))}{\partial t} = 0 \quad (3.3)$$

From Maxwell's equations the full-vector wave equation is obtained for magnetic field $H(r)$ [64]:

$$\nabla \times \left[\frac{1}{\epsilon(r)} \nabla \times H(r) \right] = \left(\frac{\omega}{c} \right)^2 H(r) \quad (3.4)$$

$$c = \frac{1}{\sqrt{\epsilon_0 \mu_0}} \quad (3.5)$$

Where, dielectric constant is represented by the $\epsilon(r)$ of the structure, c depicts speed of light in free space, and ω represents the angular frequency of the wave.

3.3 Simulation Setup

The block diagram of proposed framework is shown in Fig. 3.1. At transmitter section, an input feed line is present which provides a constant light to the waveguide. This waveguide works as a channel, which consists of photonic crystals. The wavelength of the light source is $1.9 \mu\text{m}$. The substrate used in the crystal whose dielectric constant is equivalent to $\epsilon_r=3.1$. The distance between the two photonic crystals is $1\mu\text{m}$ and the radius of the photonic crystal is $0.3 \mu\text{m}$. The signal from the transmitter through the waveguide is evenly distributed between two channels which is made by line defects in photonic structure. Then the light is fed to FBG, here the FBG is used as optical sensor for sensing application and it can also use as FBG filter in communication field. When FBG is used in sensing application then the FBG reflects the light with Fresnel principle, from where we can observe the behavior the waveguide in different situation. In proposed system two channel is used as a sensor in different filed.

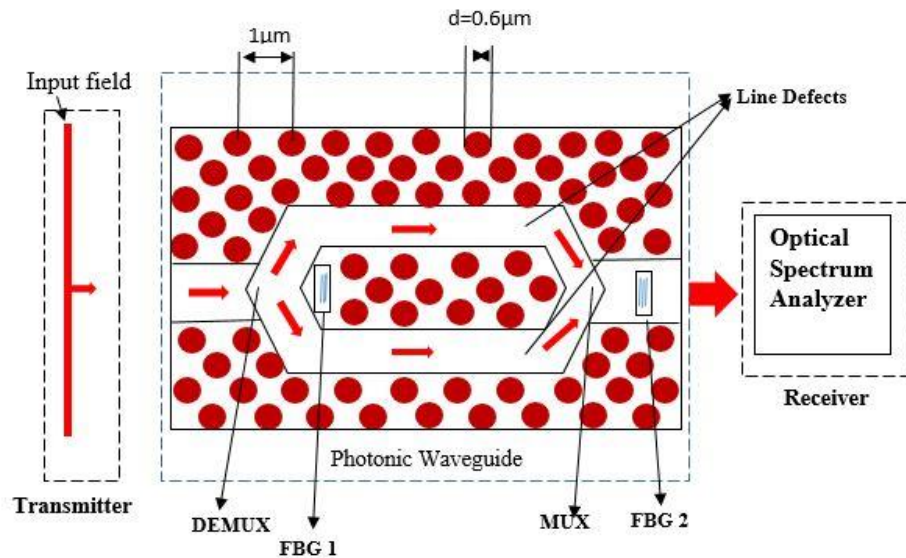

Figure 3.1: Full duplex WDM Hybrid sensor using line defects

When FBG filter is used in communication field then the light reflects a particular optical wavelength for upstream transmission and transmits all others of the downstream signal, which make it possible to increase the number of user at same wavelength. At the receiving end of the waveguide channel, these two signals are multiplexed and again the signal is passed through another FBG filter (FBG2). Then the received signal is investigated by using an optical spectrum analyzer.

3.4 Results and Discussion

Fig. 3.2 represents the amplitude values of the light source through the width of the waveguide for different intensity power (W/m) and at different waveguide positions. We have observed that the light is distributed all along the waveguide with intensity $3.675 \mu\text{W/m}$, $0.88 \mu\text{W/m}$ and $-16.33 \mu\text{W/m}$ at position of waveguide $0.5 \mu\text{m}$, $16.09 \mu\text{m}$ and $20.8 \mu\text{m}$, respectively. The proposed system achieved maximum intensity of light at position $16.09 \mu\text{m}$.

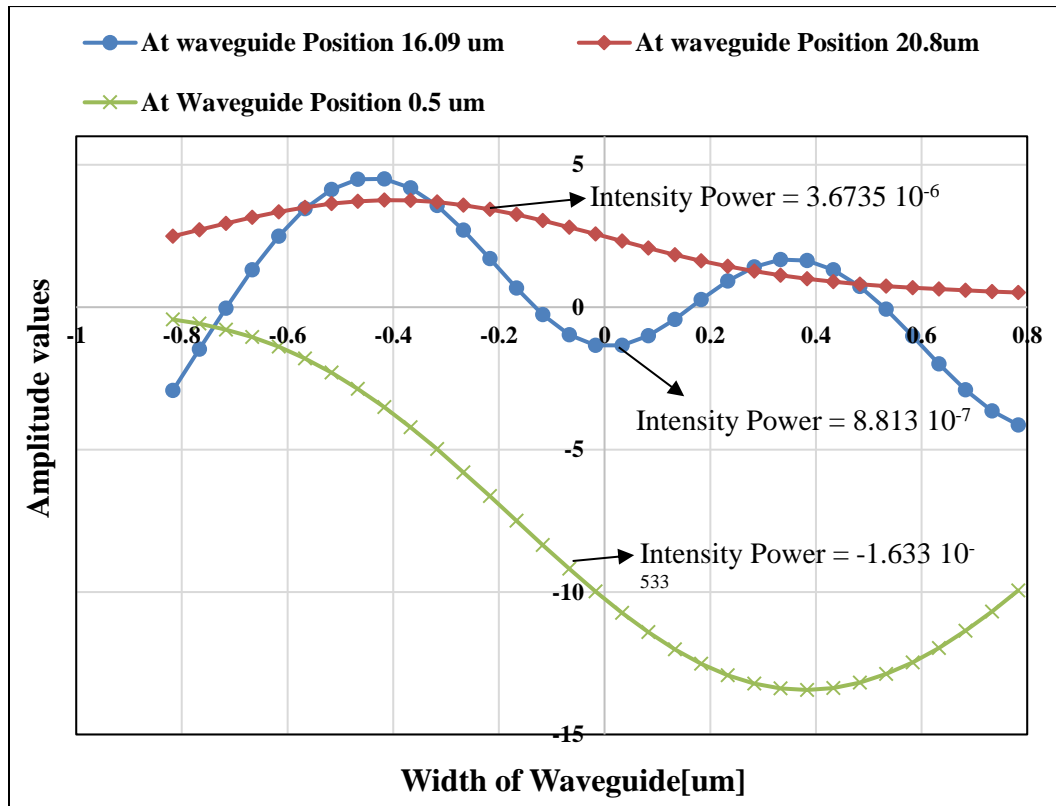

Figure 3.2: Variation of Amplitude values as function of width of waveguide

Fig. 3.3 represents variation of the reflection power of the two FBG's with respect to the wavelength. From the results it can be observed that, the proposed system give us reflection of two FBG sensor simultaneously. It can be work together in different sensing field.

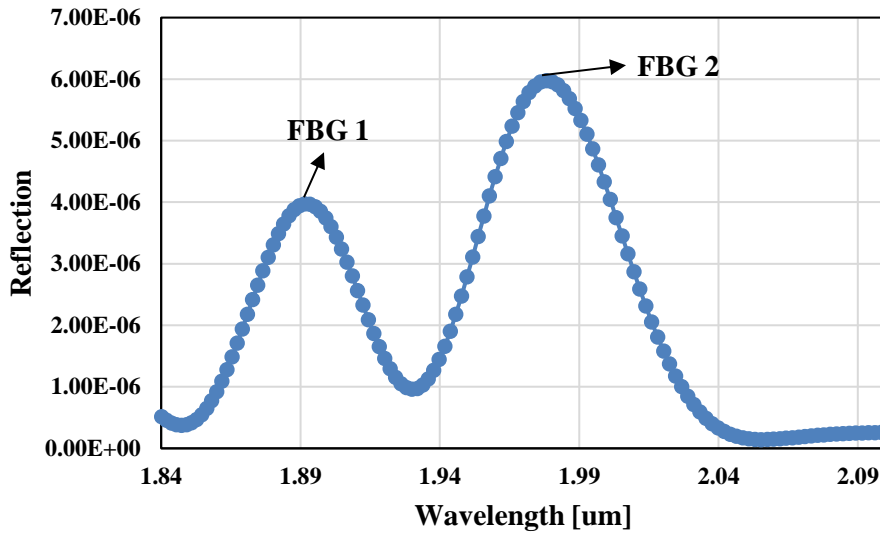

Figure 3.3: Reflection of FBG 1 and FBG2 as function of wavelength

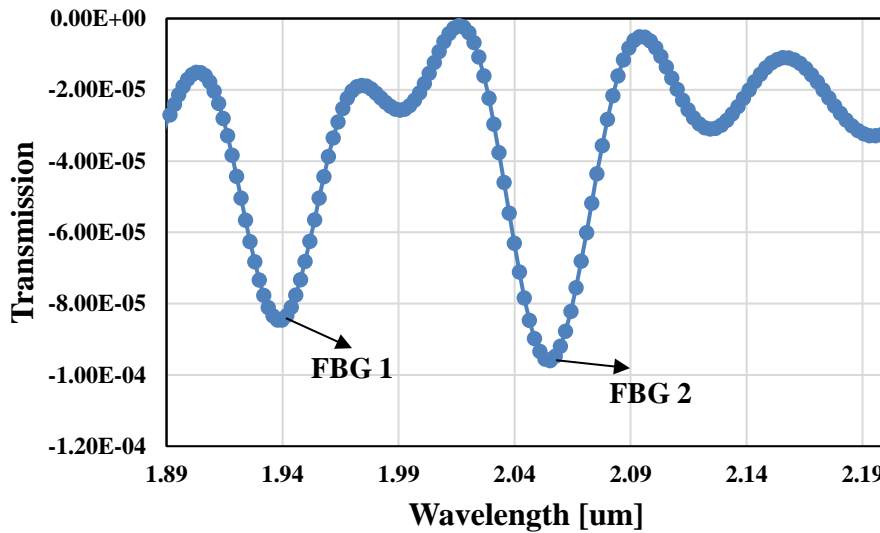

Figure 3.4: Transmission for FBG1 and FBG2 as a function of wavelength

Fig. 3.4 depicts the variation of transmission power with respect to the wavelength. The transmission power is varied from 10^{-4} to 10^{-6} . We notice that proposed system gives us

valid transmission power as we want from optical sensor. The proposed system can be used in different application such as in communication field (use as full duplex system), civil engineering to monitor the deformation of structure, harbors, recreation zones, bridge etc.

3.5 CONCLUSION

We studied the effect of optical hybrid sensor based on the technique of wavelength division multiplexing using Photonics crystal fiber and Fiber Bragg Grating. In the proposed system, a full duplex system is established for transmitting and receiving of the data simultaneously to reduce the processing time. In proposed system, line defect techniques are used to create linear waveguide channels and each channel is used as optical sensor. We have achieved the variation in reflection and the transmission power with proposed system. From the results it can be suggested that the proposed system can be used as in communication filed for data transmission and also used in sensing application to sense the property and deformation of object.

INVESTIGATION ON CO-OFDM USING COHERENT DETECTION IN OPTICAL COMMUNICATION SYSTEM

In this chapter, study the effect of various subcarriers in coherent optical orthogonal frequency division multiplexing (CO-OFDM) using Dual Polarization Quadrature Phase Shifting Keying (DP-QPSK) modulation technique. The performance of the proposed system is investigated in terms of bit error rate (BER), received optical power and constellation diagrams of the received signals.

4.1 INTRODUCTION

Optical transmission technology has progressed extensively in current years to encounter the growing demands of users and broadband service providers. So, it's high time for the development in a technology that can support the rapidly growing internet bandwidth necessity [65]. One of the possible solutions for providing broadband capacity and transmission stability is OFDM [66]. The OFDM based setups are globally accepted as optical access network solutions for allotting judiciously high bandwidth to the users [67]. But the major drawback of WDM is that it possess a lot of complexity in the transmitter and receiver domain, and it is uneconomical to use WDM for this purpose because of its wide channel application. On the other hand, OFDM offers flexibility and reasonably priced for the users. OFDM also satisfies the people craving for the high bandwidth requirement [68]. Coherent optical OFDM scheme is used to transmit data at terabit rate for long haul purposes [69]. Procedures corresponding to flexible grid, allocation of an elastic channel and cognitive optical networks are constantly under many researchers' concern [70]. Many of the optical networks which are flexible in nature and widely used in numerous optical topologies, the CO-OFDM are strappingly capable to substitute WDM. To use effective adaptive transponders performance, they must have the capability to perform while dealing with adaptable quantity of subcarriers and data rates [71]. Many researchers have already addressed the same problem and made progress to provide a solution. Silva et al. [72] developed a coherent optical transmission system to increase

spectral efficiency in a WDM system. It was reported that, the proposed system achieved 287.5 GHz bandwidth with spectral efficiency of 3.75 b/s/Hz. Huang et al. [73] experimentally demonstrated the generation and detection of 400 Gb/s single carrier DP-16QAM using 100GbE-grade. Various analog components are also incorporated in proposed system such as modulators, drivers and photodetectors. It was conveyed that, WDM transmission was successfully demonstrated over 121.2 Km distance with 5.33 b/s/Hz spectral efficiency. L. Jianping et al [74] theoretically studied the stability of single sideband modulator based on recirculating frequency shifter (RFS). It was conveyed that, multipath interference induced crosstalk is an important factor that distresses the stability of the RFS and optimal operation conditions can be obtained with the help of given system parameter.

Previously proposed frameworks were suitable for short haul signal transmission where the number of subcarriers needed a reduction in order to increase the transmission distance and eliminate inter-carrier interference, which as a result diminishes the system performance. Other schemes will take the advantage of raman amplification and various techniques like NGI-OFDM, dense wavelength division multiplexing (DWDM) in order to accomplish further high transmission distances and which were relatively expensive to implement practically.

In this chapter, CO-OFDM is proposed and the dispersion is compensated using post coherent detection module. After introduction, the chapter is sorted out as follows: In section 4.2, the simulation setup of the proposed scheme is discussed. In section 4.3, results are discussed in detail and conclusion is drawn in section 4.4.

4.2 SIMULATION SETUP

The systematic diagram of the proposed framework is publicized in Fig. 4.1. At the transmission side, a CW laser with a functioning frequency of 193.1 THz and linewidth of 0.1 MHz is used. The input power of channel is set to 0 dBm. A pseudo random bit sequence (PRBS) generator (whose baud rate is initialized at the value of 12.5 Gbaud, whose length is fixed at $2^{15}-1$) is used to initiate an OFDM modulator in order to generate a 25Gbps baseband signal. This is divided into two parts using a polarization splitter, which

is connected to their corresponding OFDM blocks (OFDM X and OFDM Y) due to the use of dual polarization technique.

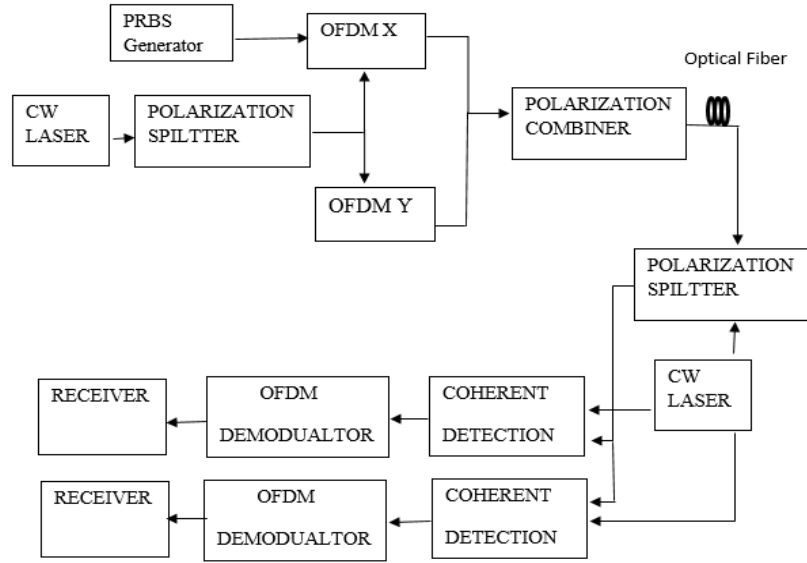

Figure 4.1: Block diagram of CO-OFDM with DP QPSK

Then these signals after undergoing through OFDM modulation are constructively interfered using the polarization combiner. After the synchronization of these OFDM modulated signals it is transmitted through the simple single mode fiber which is accompanied with a loop controller which assists in varying the distance of the system and verifying the extent through which signal the signal can be transmitted. At the receiver side, after travelling through the recirculating loop the signal is again divided into two parts with the help of polarization splitter. These divided signals have to confront the coherent detection. This coherent detection is done with the help of the laser source whose frequency is 193.1 THz which is divided into two parts with the help of polarization splitter. Each of them will go through coherent detection. After coherent detection, these two polarized signals X and Y are demodulated with the help of OFDM demodulators X and Y respectively.

4.3 RESULTS

Fig. 4.2(a) to 4.2(b) depicts the optical spectrum of the transmitted signals and received signal at various distances Fig. 4.2(a) represents the the transmitted signal's optical

spectrum. Fig 4.2(b) shows the transmitted signal's optical spectrum received after the single mode fiber. From the following diagrams we can infer that optimum optical spectrum is achieved when the signal can be propagated through the distance of 300km with acceptable range of power.

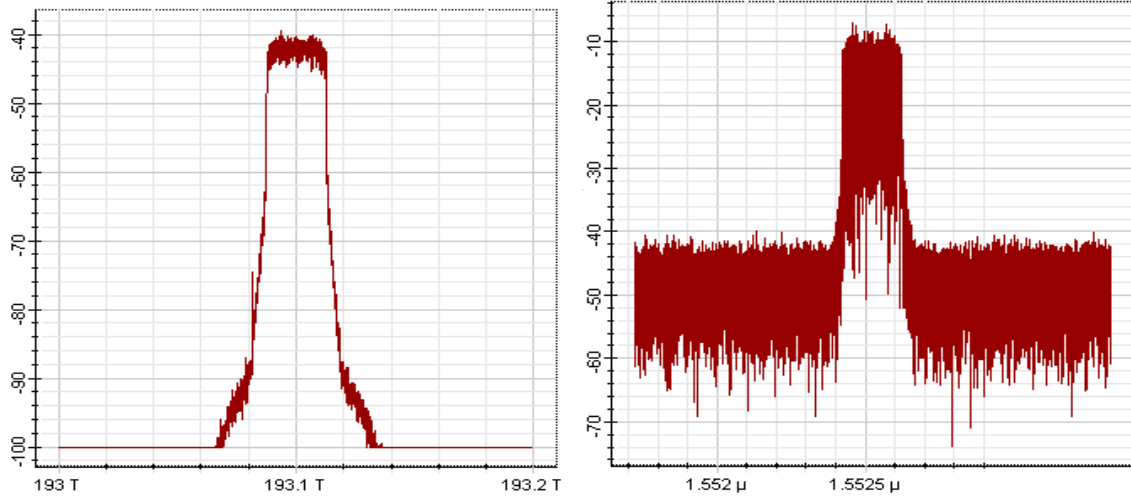

(a)

(b)

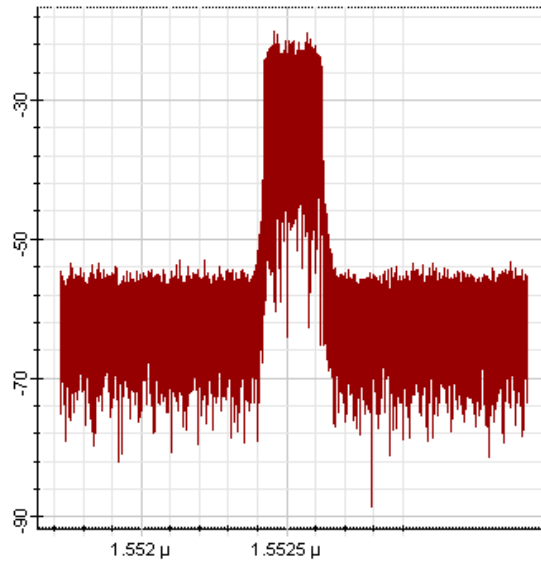

(c)

Figure 4.2: Optical spectrum of: (a) transmitted signal after the OFDM modulation (b) transmitted signal after the fiber length 10 km (c) transmitted signal after the fiber length 100 km (d) transmitted signal after the fiber length 300 km

From Fig. 4.3, it can be resolved that the behavior of central subcarriers and its two neighboring subcarrier with regard to the distance commutated through the recirculating loop and the fiber.

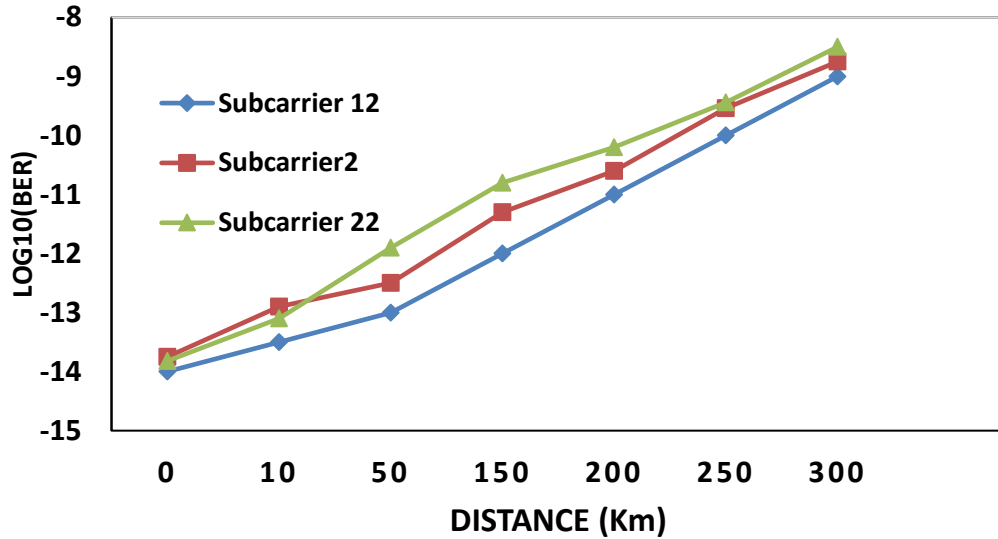
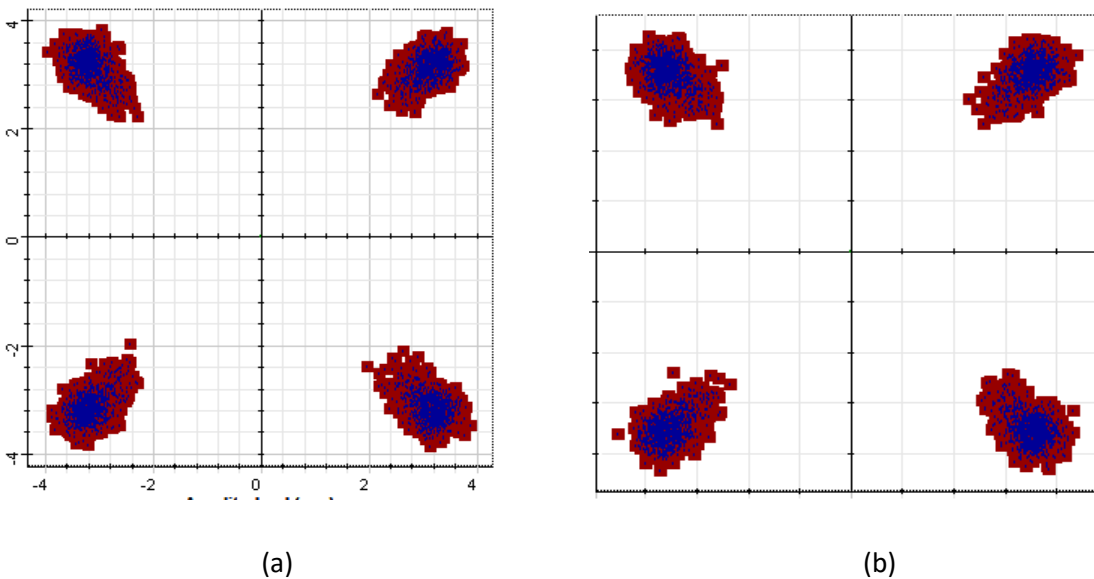
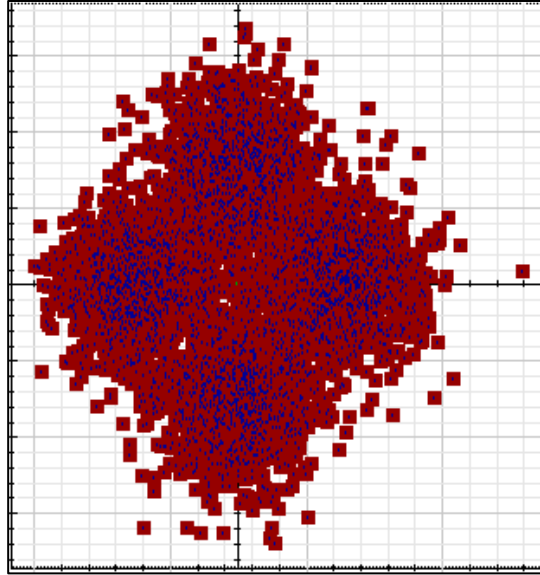

Figure 4.3: BER a function of distance for different subcarriers

From Fig. 4.3, it can be resolved that the subcarrier 12 gives the better performance when compared to other carriers. For instance, at a distance close to 50 km, the corresponding values of BER for subcarriers 2, 12 and 22 from the above graph are $10^{-12.5}$, 10^{-13} , $10^{-11.9}$ respectively.





(c)

Figure 4.4: constellation diagram for coherent detector for X polarized signal at
 (a) 10 km (b) 100km (c) 300 km

For better clarification, constellation diagrams are taken for the proposed system. Fig. 4.4 to 4.5 shows the constellation diagram at the coherent detector for X polarization signal and for Y polarization signal at different length of fiber.

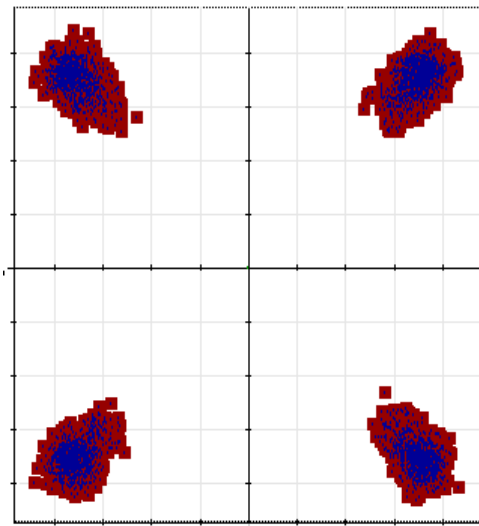

(a)

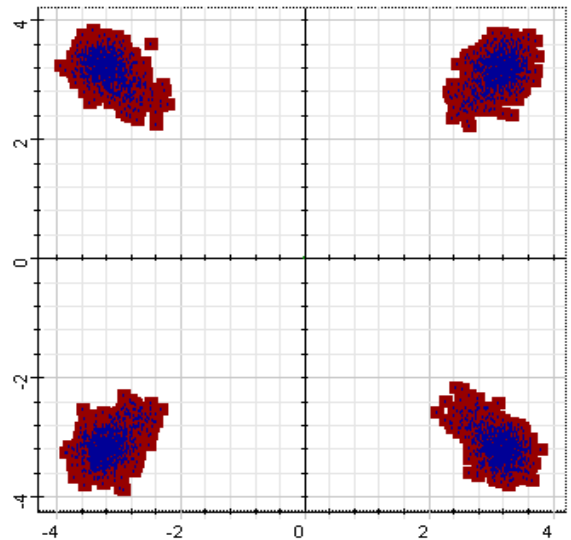

(b)

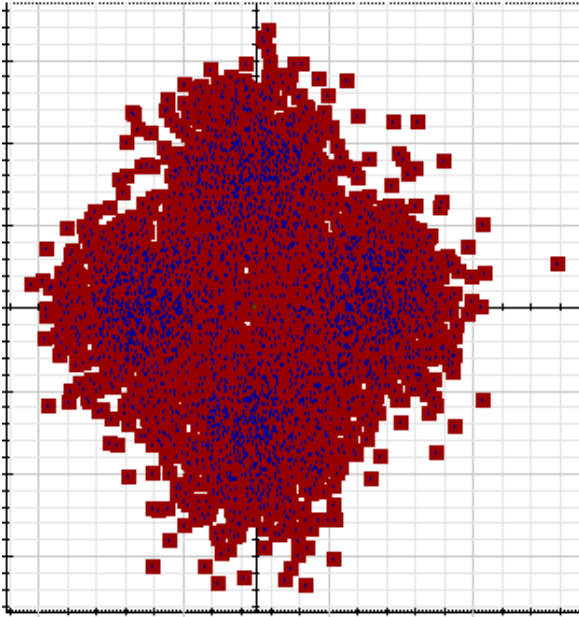

(c)

Figure 4.5: Constellation diagram for coherent detector for Y polarized signal (a) 10 km (b) 100 km (c) 300 km

From the graphs and constellation diagrams of each coherent detector, we came to this deduction that we are getting the desired outcomes upto the distance of 250 km.

4.4. CONCLUSION

In this chapter, CO-OFDM modulation technique with DP-QPSK scheme using EDFA amplification is proposed and investigated. We demonstrated that using coherent detection at the receiver end reduces the dispersion. The system provides satisfactory values of BER upto a transmission distance of 300 km. Thus, the proposed system can be implemented for long distance propagation. The system competence can further be enhanced by incrementing the number of users in the arrangement.

5.1 CONCLUSION AND RECOMMENDATION

This chapter is accountable for the synopsis of the research work done in this dissertation. First some deductions are being formulated from this study, then several recommendations are being specified on the base of the conclusions and then the scope for the further examination is discussed. The main results acquired in this thesis are concluded and encapsulated below:

1. We studied the effect of optical hybrid sensor based on the technique of wavelength division multiplexing using Photonics crystal fiber and Fiber Bragg Grating. In the proposed system, a full duplex system is established for transmitting and receiving of the data simultaneously to reduce the processing time. In proposed system, line defect techniques are used to create linear waveguide channels and each channel is used as optical sensor. We have achieved the variation in reflection and the transmission power using Fiber Bragg Grating with proposed system. From the results it can be suggested that the proposed system can be used as in communication filed for data transmission and can also be used in sensing application to sense the property and deformation of object.
2. CO-OFDM modulation technique with DP-QPSK scheme using EDFA amplification is proposed and investigated. We demonstrated that using coherent detection at the receiver end reduces the dispersion. The system provides satisfactory values of BER upto a transmission distance of 300 km. Thus, the proposed system can be implemented for long distance propagation. The system competence can further be enhanced by incrementing the number of users in the arrangement. Chromatic Dispersion is compensated using post coherent detection module.

5.2 FUTURE SCOPE:

During the course of this dissertation, several avenues for continuation of this study became

evident. The topics which were considered worthwhile are summarized below:

1. In this dissertation, we studied the effect of two users simultaneously using two line defects and Photonics crystal fiber and Fiber Bragg Grating in a waveguide. The number of users can be improved for future purposes. The system used 1×2 Wavelength Division De-Multiplexing and multiplexing format, while it can be extended to $1 \times n$, where n represents the number of different users.
2. We can use CO-OFDM systems for long haul transmissions and increasing the quantity of the users can be done. We can apply Raman amplifier and Vertical Cavity SOA instead using EDFA.
3. Higher data rate systems can be generated by increasing the number of subcarriers correspondingly the behavior BER can be analyzed as a function of input OSNR.

REFERENCES

- [1]. K. Buddharaju, "Design of Power Efficient Multicast Algorithms for Sparse Split WDM Networks", A Master's thesis, Dept. of Electrical Engineering, Louisiana State University, Baton Rouge, 2003.
- [2]. F. Mitschke, *Fiber optics: physics and technology*, Heidelberg, New York: Springer, 2009.
- [3]. K. T. V. Grattan and T. Sun, "Fiber optic sensor technology: an overview," *Sensors and Actuators A*, vol. 82, no. 1, pp. 40-61, 2000.
- [4]. G. Rajan, "Introduction to optical fiber sensors," in *Optical fiber sensors: advanced techniques and applications*, CRC press, 2015, pp. 1-12.
- [5]. A. R. Pinto and M. Lopez, "Photonic crystal fibers for sensing applications," *Journal of Sensors*, vol. 2012, pp. 1-21, 2012.
- [6]. B. Troia, A. Paolicelli, F. D. Leonardis and V. M. N. Passaro, "Photonic crystals for optical sensing: a review," *Advances Photonic Crystals*, pp. 241-295, 2013
- [7]. K.O.Hill, "Photosensitivity in Optical Fiber Waveguides: From Discovery to Commercialization", *IEEE Journal on Selected Topics in Quantum Electronics*, vol 6, pp.1186-1189, 2000.
- [8]. Herszberg, H. Li, H.C. Dharmawan, F. Mouritz, A.P. Nguyen, M., Bayandor, "Damage assessment and monitoring of composite ship joints", *Composite Structures*, vol. 67, pp. 205-216, 2005.
- [9]. J.S. Baldwin, C.S. Slater, "Structural Load Monitoring of RV Triton using Fibre Optic Sensors", *Smart Structures and Materials*, vol.v4698, pp. 462-472, 2002.
- [10]. C.A. Brooks, M.E. Froggatt, S.G. Allison, T.C. Moore, "Use of 3000 Bragg Grating Strain Structured Distributed on Four Eight-meter Optical Fibers During Static Load Tests of a Composite Structure", *NASA Langley Research Center*, 2001.
- [11]. A. T. Alavie, R. Maaskant, R. Stubbe, A. Othonos, M. Ohn, B. Sahlgren "Characterization of Fiber Bragg Grating Sensors and their Relation to Manufacturing Technique," *Proceedings of SPIE*", pp. 528-535, 1995
- [12]. B. Troia, A. Paolicelli, F. D. Leonardis and V. M. N. Passaro, "Photonic crystals

- for optical sensing: a review," in *Advances in Photonic Crystals*, pp. 241-295 2013.
- [13]. S. A. Cerqueira, "Recent progress and novel applications of photonic crystal fibers," *Reports on Progress in Physics*, vol. 73, no. 2, pp. 1-21, 2010.
- [14]. B. Culshaw, "Fiber optics in sensing and measurement," *IEEE Journal on Selected Topics in Quantum Electronics*, vol. 6, no. 6, pp. 1014-1021, 2000.
- [15]. J. Villatoro, V. P. Minkovich and D. M. Hernandez, "Temperature-independent strain sensor made from tapered holey optical fiber," *Optics letters*, vol. 31, no. 3, pp. 305-307, 2006.
- [16]. J. Villatoro, V. Finazzi, V. P. Minkovich, P. V. and G. Badenes, "Temperature insensitive photonic crystal fiber interferometer for absolute strain sensing," *Applied Physics Letters*, vol. 91, no. 9, pp. 1-3, 2007.
- [17]. O. Frazao, J. M. Baptista and J. L. Santos, "Temperature independent strain sensor based on a Hi-Bi photonic crystal fiber loop mirror," *IEEE Sensors Journal*, vol. 7, no. 10, pp. 1453-1455, 2007.
- [18]. Q. Shi, F.Lv, Z.Wang, L.Jin, Z. J.J. Hu, G.Kai and X.Dong, "Environmentally stable Fabry-Perot-type strain sensor based on hollow-core photonic bandgap fiber," *IEEE Photonics Technology Letters*, vol. 20, no. 4, pp. 237-239, 2008.
- [19]. Y. G. Han, "Temperature-insensitive strain measurement using a birefringent interferometer based on a polarization maintaining photonic crystal fiber," *Applied Physics B*, vol. 95, no. 2, pp. 383-387, 2009.
- [20]. W. Qian, C. L. Zhao, X. Dong and W. Jin, "Intensity measurement based temperature independent strain sensor using a highly birefringent photonic crystal fiber loop mirror," *Optics Communications*, vol. 283, no. 24, pp. 5250-5254, 2010.
- [21]. R. W. Chang, "Synthesis of band-limited orthogonal signals for multichannel data transmission," *Bell Labs Tech. Journal*, vol. 45, no. 10, pp. 1775-1796, 1966.
- [22]. B. Saltzberg, "Performance of an efficient parallel data transmission system," *IEEE Transactions on Communications, IEEE*, vol. 15, no. 6, pp. 805-811, 1967.

- [23]. A.J. Lowery, "Performance of Orthogonal-frequency-division multiplexing in ultra-long-haul WDM systems," *Journal of Lightwave tech.*, vol. 25, pp. 2079-2084, 2007.
- [24]. M.S. Moreolo, J.M. Fàbrega, L. Nadal, F. J. Vílchez, "Software- Defined Optical OFDM Transmission Systems: Enabling Elasticity in the Data Plane," *Conference paper on Transparent optical networks*, vol. 23, pp. 1–4, July 2012.
- [25]. L. J. Cimini, "Analysis and simulation of a digital mobile channel using orthogonal frequency division multiplexing," *IEEE Transactions on Communications*, vol. 33, no.7, pp. 665-675, 1985.
- [26]. R. Lassalle, and M. Alard, "Principles of modulation and channel coding for digital broadcasting for mobile receivers," *EBU Tech.*, vol. 224, pp. 168-190, 1987.
- [27]. O. Gonzalez, R. Perez-Jimenez, S. Rodriguez, J. Rabadan, and A. Ayala, "Adaptive OFDM system for communications over the indoor wireless optical channel," *IEEE proceedings on Optoelectronics*, vol. 153, issue 4, pp. 139-144, 2006.
- [28]. J. Grubor, V. Jungnickel, and K. D. Langer, "Adaptive optical wireless OFDM system with controlled asymmetric clipping," In *Signals, Systems and Computers, IEEE Conference*, pp. 1896-1902, November 2007.
- [29]. S. Hara, R. Prasad, "Multicarrier Techniques for 4G Mobile Communications", 2003.
- [30]. L. Hanzo, M. Munster, B.J. Choi, T. Keller, "OFDM and MC-CDMA for Broadband Multi-User Communications, WLANs and Broadcasting," *ArteHouse*, 2003.
- [31]. Chi-Tsong Chen "System and Signal Analysis" Thomson, 1988.
- [32]. W. Shieh, Y. Tang, and B. S. Krongold, "DFT-spread OFDM for optical Communications," *9th International Conference IEEE on Optical Internet* pp. 1-3, 2010.
- [33]. W. Shieh, I. Djordjevic, "OFDM for Optical Communications", *Elsevier*, Amsterdam, 2009.
- [34]. Y. Benlachtar, R. Bouziane, R. I. Killey, C. R. Berger, P. Milder, R Koutsoyannis,

- J. Hoe, "Optical OFDM for the Data Center," *International conference on Digital Object Identifier*, vol. 2, pp. 4244-7798, 2010.
- [35]. B. Pirom, P. Kaewplung, "Analysis of Phase Distortion in Optical OFDM Signal Transmission in Optical Fiber", *International Conference on Information and Multimedia Technology*, vol. 9, pp. 465–469, 2009.
- [36]. H. Chen and H. Liang, "A Modified Selective Mapping with PAPR Reduction and Error Correction in OFDM Systems," *IEEE trans.*, vol. 7, pp. 1525 - 3511, 2007.
- [37]. L. Liu, "Chromatic dispersion compensation using two pilot tones in optical OFDM system", *IEEE Trans.*, vol. 8309, pp. 1-6, 2011.
- [38]. H. Louchet, A. Richter, "Novel scheme for high-bit-rate Coherent OFDM transmission without PLL," *IEEE Trans.*, Vol. 18, pp. 1-2, September 2007.
- [39]. J. Pan and C.H. Cheng, "Nonlinear Electrical Predistortion and Equalization for the Coherent Optical Communication System," *J. of Lightwave Tech.*, vol. 29, no. 18, pp. 2785-2789, 2011.
- [40]. G. Zhanget et al., "A Survey on OFDM-Based Elastic Core Optical Networking," *IEEE Communications Surveys & Tutorials*, vol. 15, No. 1, pp. 65-87, 2013.
- [41]. S. Hussin et al., "Performance Analysis of Optical OFDM Systems," *IEEE Trans.*, vol. 7, pp. 1-5, 2011.
- [42]. C. Lim, M. Attygalle, A. Nirmalathas, D. Novak, and R. Waterhouse, "Analysis of Optical CSR for Improving Transmission Performance Fiber-Radio Links," *IEEE Trans.*, vol. 54, no. 1, pp. 2181-2187, 2006.
- [43]. H. Bao and W. Shieh, "Transmission simulation of coherent optical OFDM signals in WDM systems", *Opt. Express*, vol. 15, pp. 4410-4418, 2007.
- [44]. W. H. Chen, "Multichannel single-sideband SCM/DWDM transmission systems", *Journal Lightwave Technology, IEEE*, vol. 22, pp. 1690-1693, 2004.
- [45]. I. Kashany, Mizrahi, "Low-cost adaptive directly modulated optical OFDM based on semiconductor optical amplifier," *Optical Fiber Technology*, vol. 19, Issue 5, pp. 501-506, 2013.
- [46]. J. Zhao, "Pilot tone design for dispersion estimation in coherent optical fast OFDM Systems," *Optics communication*, vol. 298, pp. 75-78, July 2013.
- [47]. R.W. Bauml, R.F.H. Fischer, J.B. Huber, "Reducing the PAPR of multicarrier

- modulation by SLM,” *IET Electron*, letter 32, vol. 32, pp. 2056–2057, 1996.
- [48]. J. A. L. Silva, A. V. T. Cartaxo, and M. E. V. Segatto, “a PAPR reduction technique based on a Constant Envelope OFDM approach for fiber nonlinearity mitigation in optical direct detection systems,” *Journal of Optical Communication Network*, vol. 4, no. 4, 2012.
- [49]. S. Rota-Rodrigo, A. M. R. Pinto, M. Bravo and M. L. Amo, "An in-reflection strain sensing head based on a Hi-Bi photonic crystal fiber," *Sensors*, vol. 13, no. 7, pp. 8095-8112, 2013.
- [50]. W. Zhou, W. C. Wong, C. C. Chan, L. Y. Shao and X. Dong, "Highly sensitive fiber loop ring down strain sensor using photonic crystal fiber interferometer," *Applied Optics*, vol. 50, no. 19, pp. 3087-3092, 2011.
- [51]. T. G. Giallorenzi, J. A. Bucaro, A. Dandridge and G. H. Sigel, “Optical Fiber Sensor Technology”, IEEE Transactions On Microwave Theory And Techniques, vol. 30, no. 4, pp. 472-510, 1982.
- [52]. A. Yariv and H. Winsor, “Proposal for Detection of Magnetostrictive Perturbation of Optical Fibers”, Optics Letter, vol. 5, pp. 87-89, 1980.
- [53]. G. Rajan, "In Optical Fiber Sensors: Advanced Techniques and Applications”, CRC Press, Taylor & Francis Group, pp. 1-12, 2015.
- [54]. J. A. Bucaro, J. H. Cole, J. Jarzynski, W. K. Burns and T. G. Giallorenzi, “Optical Fiber Sensor Technology”, Optoelectronic Technology and Lightwave Communications Systems, pp 600-652, 1981.
- [55]. J.L. Gehrich, D.W. Lubbers, N. Opitz, D.R. Hansmann, W.W. Miller, J.K. Tusa and M. Yasufo, “Optical Fluorescence and Its Application to an Intravascular Blood Gas Monitoring System”, IEEE Trans. Biomed. Eng., vol. 33, pp. 117-132, 1986.
- [56]. R. Narayanaswamy, “Optical Sensors,” IEEE international conference on new techniques in pharmaceutical and biomedical research, pp. 1-4, 2005.
- [57]. N. Agrawal, C. C. Davis and S. D. Milner, “Free Space Optical Sensor Networking For Underwater Sensing Applications”, Intelligent Sensors, Sensor Networks and Information Processing (ISSNIP), 2009 5th International Conference on. IEEE, pp. 475-480, 2009.

- [58]. W. Kunzler, Z. Zhu, R. Selfridge, S. Schultz and M. Wirthlin, "Integrating Fiber Bragg Grating Sensors with Sensor Networks", IEEE Autotestcon, pp. No 1-4, 2008.
- [59]. H. Zhiqi, H. Yujun, H. Lizhang, Z. Miao and W. Zishuo, "Optical Fiber Bragg Grating Center Of Wavelength Detection Filter Algorithm", IEEE, 10th International Conference on Electronic Measurement & Instruments (ICEMI), vol. 4, pp. 90-94, 2011.
- [60]. N. Muduli, G. Palai and S.K. Tripathy, "Modeling A Hexagonal Periodic Photonic Crystal Fiber For Optical Communication", International Conference On Microelectronics, Communication And Renewable Energy, vol, 7, no. 2, pp. No. 1-4, 2013.
- [61]. Y. F. Li, C. Y. Wang and M.L. Hu, "A Fully Vectorial Effective Index Method for Photonic Crystal Fibers: Application To Dispersion Calculation", Optics Communications, vol. 238, no. 1, pp. 29–33, 2004.
- [62]. J. I. Peterson, G.G. Vurek, "Fiber-Optic Sensors For Biomedical Applications", Science, pp.123-127, 1984.
- [63]. R. Seena, R. Pradeep and N. Vijayakumar, "A Full Duplex Radio Over Fiber System Using Fiber Bragg Grating Filter," International Conference On Computational Systems And Communications, Trivandrum, pp. 139-143, 2014.
- [64]. R. Buczynski, "Photonic Crystal Fibers", Acta Physica Polonica , vol. 106, no. 2, pp. 141-168, 2004
- [65]. G. Zhang, D. Leenheer, "A Survey on OFDM-Based Optical Networking", Communications Surveys & Tutorials, IEEE, vol. 15, no. 1, pp. 65-87, 2013.
- [66]. N. Marchetti, "OFDM: Principles and Challenges", New direction in wireless communications research, vol. 26, no. 19, pp. 29-35, 2009.
- [67]. V. D. Borne, V. Dirk, M. S. Alfiad and S. L. Jansen, "Towards 400G and beyond: How to design the next generation of ultra-high capacity transmission systems", Opto-Electronics and Communications Conference (OECC), vol. 14, pp. 429-432, 2011.
- [68]. K. Iniewski, "Internet Networks: Wired, Wireless, and Optical Technologies. Devices, Circuits, and Systems", CRC Press, 2009.

- [69]. W. Shieh, "Coherent optical orthogonal frequency division multiplexing", *Electronics Letters*, vol.42, no. 10-20, pp. 1-2, 2006.
- [70]. I. D. Miguel, R. J. Duran, "Cognitive Dynamic Optical Networks [Invited]", *Journal of Optical Communications and Networking*, vol. 5, no. 10, pp. A107-A118, 2013.
- [71]. G. Zhang; D. Leenheer, "A Survey on OFDM-Based Elastic Core Optical Networking", *IEEE Communications Surveys & Tutorials*, vol.15, no.1, pp. 65-87, 2013.
- [72]. E. P. Silva, D. M. Pataca, "Transmission of NGI-OFDM DP-QPSK with EDFA-only amplification", *Journal of Microwaves, Optoelectronics and Electromagnetic Applications*, pp. 96-103, 2013.
- [73]. Y. K. Huang, S. Zhang, "Single Carrier 400G WDM Transmission with EDFA-Amplified Link Using 4-PAM to 16-QAM Conversion", *19th Optoelectronics and Communications Conference (OECC) and the 39th Australian Conference on Optical Fibre Technology (ACOFT)*, vol. 15, no. 1, pp. 6-10, 2014.
- [74]. L. Jianping, L. Xuan and Z. Xiaoguang, "Analysis of the Stability of Recirculating Frequency Shifter Used as a Multi-Tone Wideband Light Source for Tb/s Multi-Carrier Optical Transmission", *European Conference and Exhibition on Optical Communication*, vol. 19, pp. 19-23, 2010.
- [75]. K. Roberts, M. Sullivan, "Performance of Dual-Polarization QPSK for Optical Transport Systems", *Journal Of Lightwave Technology*, vol. 27, no. 16, pp. 3536-3559, 2009