

A
Thesis Report
On
PAPR Evaluation of 3GPP LTE Physical Layer

Submitted towards the partial fulfilment of requirement for the award of degree of

Master of Engineering
In
Wireless Communication Engineering

Submitted by:

Hiten Setia

(801263010)

Under the guidance of:

Dr. Hem Dutt Joshi



ELECTRONICS AND COMMUNICATION ENGINEERING DEPARTMENT

THAPAR UNIVERSITY

(Established under the section 3 of UGC Act, 1956)

PATIALA – 147004 (PUNJAB)

July, 2014-07-18

DECLARATION

I hereby declare that the thesis report entitled "PAPR Evaluation of 3GPP LTE Physical Layer" is an authentic record of my study carried out as requirement for the award of degree of ME (Wireless Communication Engineering) at Thapar University, Patiala, under the supervision of "Dr. Hem Dutt Joshi" ("Electronics and Communication Engineering department") during 4th semester, 2012-2014.

Date: 18-07-2014

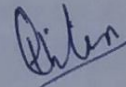

"Hiten Setia"

(801263010)

It is certified that the above statement made by the student is correct to the best of my knowledge and belief.

Date: 18-07-2014



"Dr. Hem Dutt Joshi"

"ECED"

Countersigned by:

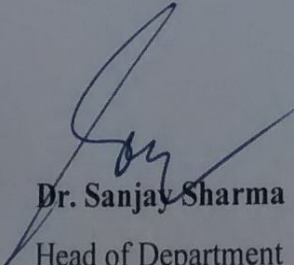

Dr. Sanjay Sharma

Head of Department

ECED, Thapar University, Patiala

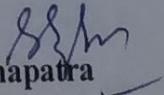

Dr. S.K. Mohapatra

Dean of Academic Affairs

Thapar University, Patiala

ABSTRACT

Communication is one of the important aspects of life. It is very difficult to survive without communication. With the advancement in age and its growing demands, there has been rapid growth in the field of communications. Signals, which were initially sent in the analog domain, are being sent more and more in the digital domain these days. For better transmission, even single-carrier waves are being replaced by multi-carriers. Multi carrier systems like CDMA and OFDM are now a days being implemented commonly. In the OFDM system, sub-carriers are placed orthogonally so that they do not interfere with each other. Presence of guard band in this system deals with the problem of ISI. But the large Peak to Average Power Ratio of these signals is a serious limitation of these systems.

In this thesis, basics of OFDMA and SC-FDMA has been studied and a no. of techniques have been surveyed for reducing the effect of PAPR in OFDM system.

ACKNOWLEDGEMENT

I would like to give special thanks to my guide **Dr. Hem Dutt Joshi** (Assistant Professor) ECED, Thapar University, Patiala, for his advice, kind assistance, and invaluable guidance. It has been a great honour to work under him.

I am also thankful to **Dr. Sanjay Sharma**, Prof. & Head, Electronics and communication Engineering Department, for providing us with adequate infrastructure in carrying the work.

I am also thankful to **Dr. Kulbir Singh**, P.G. Co-ordinator, Electronics and communication Engineering Department for the motivation and inspiration that triggered me for the report work.

I am greatly indebted to all of my friends who constantly encouraged me and also would like to thank all the faculty members of ECED for the full support of my work. I am also thankful to the authors whose work have been consulted and quoted in this work.

Hiten Setia

THESIS OUTLINE

The thesis titled “PAPR Evaluation of 3GPP LTE Physical Layer” is covered into 6 chapters.

Chapter 1 includes history of wireless communication systems, its basic model, types of fading and fading distribution.

Chapter 2 includes an introduction to 3GPP, its scope and objectives, detailed explanation of LTE physical layer for both uplink and downlink.

Chapter 3 includes detailed literature survey of PAPR reduction techniques from the best journals available.

Chapter 4 includes mathematical analysis of both multiple access techniques i.e. SCFDMA and OFDMA with block diagrams.

Chapter 5 includes results based on MATLAB simulation.

Chapter 6 contains conclusions and future work.

TABLE OF CONTENTS

DECLARATION	ii
ABSTRACT	iii
ACKNOWLEDGEMENT	iv
THESIS OUTLINE	v
TABLE OF CONTENTS	vi
LIST OF FIGURES	ix
LIST OF TABLES	xi
GLOSSARY	xii
CHAPTER 1: Introduction	1
1.1 Motivation	1
1.2 Wireless Communication	2
1.3 History and Evolution of Mobile Communication	4
1.4 Characteristics of Wireless Channel	6
1.5 Types of Fading	6
1.6 Small Scale Fading	7
1.7 Fading Distribution	9
CHAPTER 2: 3GPP LTE Physical layer	10
2.1 Introduction to 3GPP	10
2.1.1 History of 3GPP	11
2.1.2 Organizational Partner	11
2.1.3 Structure of 3GPP	11
2.1.4 Scope and Objectives of 3GPP	12
2.2 LTE Overview	14
2.2.1 Targets of LTE	15
2.2.2 Features of LTE	16
2.3 LTE Radio Protocol	16
2.4 LTE Physical layer	18
2.4.1 LTE Physical Channels of Downlink	18
2.4.2 LTE Downlink Physical Channels	18
2.4.3 LTE Downlink Transport Channels	19
2.4.4 Mapping of Transport to Physical Channels	19

2.4.5 LTE physical layer processing in Downlink	20
2.5 Multiplexing used in downlink of 3GPP LTE	21
2.5.1 Introduction of OFDM	21
2.5.2 History of OFDM system	22
2.5.3 Transmission and Reception in OFDM system	23
2.5.4 Advantages of OFDM	24
2.5.5 Major drawbacks in OFDM	24
2.5.6 Applications of OFDM	25
2.6 Uplink of 3GPP LTE	25
2.6.1 LTE Uplink Channels	26
2.6.2 Signals used in LTE uplink	26
2.6.3 LTE Uplink Transport Channels	26
2.6.4 Mapping of Uplink Transport Channels to physical Channels	26
2.6.5 Uplink Physical layer processing	27
2.7 Multiplexing used in Uplink of LTE	28
2.7.1 SCFDMA: An Introduction	28
2.7.2 SCFDMA Transmitter and Receiver	31
2.7.3 Advantages of SCFDMA	31
2.7.4 Drawbacks in SCFDMA	31
2.7.5 Applications of SCFDMA	31
CHAPTER 3: LITERATURE SURVEY	32
3.1 An Introduction to PAPR	32
3.2 CCDF	32
3.3 PAPR Reduction Techniques	33
3.3.1 Clipping and Filtering	33
3.3.2 Non linear Comanding Transform	33
3.3.3 Block Coding Techniques	34
3.3.4 SLM	34
3.3.5 PTS	34
3.3.6 Tone Reservation	35
3.3.7 Tone Injection	35
3.3.8 Active Constellation	35
3.3.9 Interleaving technique	35
3.3.10 DFT Spreading	36
CHAPTER 4: MATHEMATICAL ANALYSIS	40
4.1 OFDM Modulation and Demodulation	40
4.1.1 Orthogonality	41
4.1.2 Cyclic Prefix	42
4.2 Mathematical Analysis of PAPR	43

4.3 Mathematical Analysis of DFT Spreading	45
4.3.1 Distributed FDMA	46
4.3.2 Localized FDMA	47
4.3.3 Derivation IFDMA	47
4.3.4 Derivation LFDMA	48
CHAPTER 5: RESULTS and DISCUSSIONS	50
CHAPTER 6: CONCLUSIONS and FUTURE WORK	57
References	59

LIST OF FIGURES

Figure 1.1: Basic Communication Model	2
Figure 1.2(a): Simplex	4
Figure 1.2(b): Full Duplex	4
Figure 2.1: Targets of LTE	15
Figure 2.2: LTE Radio Protocol Stack	17
Figure 2.3: Mapping of Transport Channels	19
Figure 2.4: Downlink Modulation	20
Figure 2.5: OFDM Block Diagram	23
Figure 2.6: Mapping of Uplink Transport and Physical Channels	27
Figure 2.7: To SCFDMA	27
Figure 2.8: CRC insertion per transport block	28
Figure 2.9: SCFDMA Transmitter	29
Figure 2.10: SCFDMA Receiver	31
Figure 4.1: OFDM Modulation and Demodulation	40
Figure 4.2: Subcarrier Mapping	47
Figure 4.3: Distributed FDMA	47
Figure 4.4: Localized FDMA	48
Figure 5.1: CCDF Vs PAPR for OFDM for different subcarriers	50
Figure 5.2: CCDF Vs PAPR for LTE Uplink	51
Figure 5.3: CCDF Vs PAPR for LFDMA and OFDMA for QPSK	52
Figure 5.4: CCDF Vs PAPR for LFDMA and OFDMA for 64 QAM	53
Figure 5.5: CCDF Vs PAPR for IFDMA and OFDMA for 16 QAM	54
Figure 5.6: CCDF Vs PAPR for IFDMA and OFDMA for 64 QAM	55

LIST OF TABLES

Table 1.1: Comparison of Wireless Technologies	5
Table 2.1: Organizational Partners	11
Table 2.3: Physical layer processing downlink	20
Table 3.1: Comparison of PAPR Reduction Techniques	40
Table 6.1: PAPR for QPSK at CCDF = 10^{-1}	57
Table 6.2: PAPR for 16 QAM at CCDF = 10^{-1}	57
Table 6.3: PAPR for 64 QAM at CCDF = 10^{-1}	57

GLOSSARY OF ACRONYMS

3GPP = 3rd Generation Partnership Project

16-QAM = 16 Quadrature Amplitude Modulation

64-QAM = 64 Quadrature Amplitude Modulation

ARQ = Automatic Repeat Request

AWGN = Additive White Gaussian noise

BCCH = Broadcast Channel

BCH = Broadcast Channel

BPSK = Binary Phase Shift Keying

CCCH = Common Control Channel

CCDF = Complimentary Cumulative Distribution Channel

CRC = Cyclic Redundancy Check

DAC = Digital to Analog Converter

DCCH = Dedicated Control Channel

DFT = Discrete Fourier Transform

E-UTRA = Evolved UMTS Terrestrial Radio Access

E-UTRAN = Evolved Universal Terrestrial Radio Access Network

FDD = Frequency Division Duplexing

FFT = Fast Fourier Transform

HARQ = Hybrid Automatic Repeat Request

HSDPA = High Speed Downlink Packet Access

ICI = Inter Carrier Interference

IDFT = Inverse Discrete Fourier Transform

IFFT = Inverse Fractional Fourier Transform

ISI = Inter-symbol Interference

LFDMA = Localized Frequency Division Multiplexing

LLC = Logical Link Control

LOC = Line of Sight

MAC = Medium Access Control

MCCH = Multicast Control Channel

MIMO = Multiple Input Multiple Output

MME = Mobility Management Entity

OFDM = Orthogonal Frequency Division Multiplexing

OFDMA = Orthogonal Frequency Division Multiple Access

PAPR = Peak To Average Power Ratio

PBCH = Physical Broadcast Channel

PBFICH = Physical Control Format Channel Indicator

PCCH = Paging Control Channel

PDCCH = Physical Downlink Control Channel

PDSCH = Physical Downlink Shared Channel

PHY = Physical layer

PMCH = Physical Multicast Channel

PRACH = Physical Random Access Channel

PUSCH = Physical Uplink Shared Channel

QPSK = Quadrature Phase Shift Keying

RLC = Radio Link Control

RRC = Radio Resource Control

RRM = Radio Resource Management

UMTS = Universal Mobile Telecommunication System

WiMAX = Wireless Interoperability for Microwave Access

CHAPTER 1: INTRODUCTION

1.1 Motivation

Communication is a very important aspect of human life. Without communication, it is very difficult to imagine one's life. Previously various methods like sign languages were implemented for this purpose. As various civilizations started coming into existence, many innovative ideas came to the minds of the people – special birds and human messengers were employed to meet these challenges. As ages rolled by, post system developed and transportation vehicles like trains and ships were used to maintain link between people miles apart. But by the turn of the nineteenth century, a great leap in communication system was observed when wireless communication was introduced. After the advent of wireless communication huge change has been observed in the lifestyle of people.

In order to go along with the needs of society in the year to come as far as communication is concerned, capacity is one of the issues concerned due to increase in demand for new services. Systems with high capacity are considered to be the “hot topics” in the area of telecommunication research as in the future; applications will be there which may need a capacity of more than 1Gbps. Wireless communication which was initially implemented in analog domain is now completely replaced by digital domain [1].

Now a days, to design an efficient wireless system is a challenge considering factors like high throughput, low bit error rate ,low peak to power average ratio, low computational complexity, low frequency and time offset etc.

Our objective in this thesis is to evaluate the performance of LTE physical layer which uses SCFDMA (single carrier frequency division multiple access) in the uplink and OFDMA (orthogonal frequency division multiple access) in the downlink with adaptive modulation techniques like QPSK, 16 QAM and 64 QAM. SCFDMA is a modified form of OFDMA (also called pre-coded OFDMA). 3GPP LTE is a strong contender of fourth generation wireless system along with WiMAX. Complementary Cumulative Distribution Function (CCDF) is the parameter use for evaluation of PAPR in 3GPP LTE system. MATLAB has been used to simulate and compare the PAPR of SCFDMA and OFDMA.

1.2 Wireless Communication

The word “communication” refers to the transfer of information from one place to other in the most effective way possible. The word “wireless” means that there is no physical media between source and destination. Therefore, “wireless communication” is the transfer of information from one place to other without the help of electrical conductor. Radio waves are mostly used for cellular communication. Radio waves are made to carry information data by modulating (superimposing low frequency information wave on high frequency carrier waves which are generated by using oscillators). Wireless communication [2] is becoming popular these days with the benefits of easier installation and good data rates. The basic model of communication is shown as follows:-

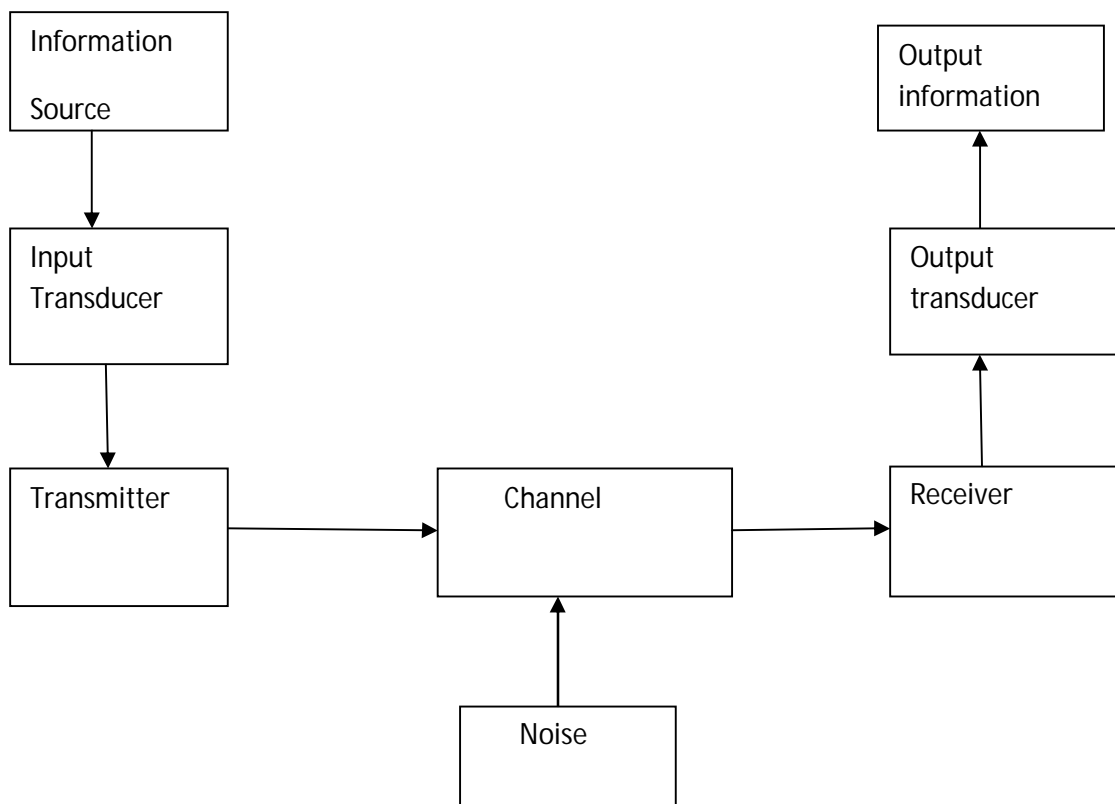

Figure 1.1: Basic Communication Model [3]

The source generates either analog signal like speech, audio or digital data like text or multimedia. A transducer is generally required to convert one form of energy into other .e.g. hydrophone converts changes in water pressure into an electrical signal.

Transmitter translates the input electrical energy into that form of energy which is suitable for efficient transmission over a given channel. Modulation is done at transmitter so as to vary characteristics like amplitude, frequency and phase in accordance with the instantaneous value of high frequency carrier waves so as to match the characteristics of a signal with that of channel and to reduce the length of antenna which is one of the main aspects while building a base station. Multiplexing which means sharing of bandwidth is also done at the transmitter side. Multiplexing is a method by which multiple message signals are combined into one signal over a shared medium. The multiplexed signal is transmitted over a communication channel. Multiplexer is a device that performs multiplexing. Mostly used multiplexing is frequency division multiple access which divides the channel into frequency slots and time division multiple access which divides the channel into different time slots.

Channel is basically the medium to transmit the signal from source to destination. In wired communication, cables act as channel and in wireless media free space (or atmosphere) acts as channel. Signals while passing through channel face drastic changes into amplitude, phase and power due to an unwanted form called noise. The received signal corrupted from noise do not contain complete data which was initially transmitted. Noise is of 2 types: internal and external. Internal noise is the noise due to thermal motion of electrons or recombination of carriers whereas external noise is due to interference from natural sources like lightning, noise coming from stars etc.

Receivers receive the signal coming from the channel. Its operation includes compensation for transmission loss to recover the message signal as good as possible that was transmitted. It demodulates the signal which means the high frequency carrier signal which was added at transmitter side is completely removed so as to extract the original signal. Output transducer converts the signal into that form which was initially transmitted.

Apart from the above functions in case of digital modulation, channel encoding and source encoding is performed at the transmitter side. Source encoding is to convert the original signal into binary bits as efficiently as possible whereas Channel encoding adds additional bits called redundant bits in a controlled manner so as to overcome effects of noise

at the receiver side. These so called redundant bits do not contain any information but are helpful in detecting errors at the receiver side.

1.3 History and Evolution of mobile communication

The basic idea of wireless communication was first introduced by G.Marconi (known as the inventor of radio) in 1897. At the turn of the 20th century, Marconi [4] started investigating means to travel the signal without the help of wired media. His company British Marconi began communication between coast radio station and ships at sea. At the start of year 1897, the transmitted a signal across Atlantic ocean. The signal was received at the other end of the ocean (which was about 35,000 kms away from initial position) after several months thus proving the experiment to be successful. Wireless communication was effectively used by military in the form of wireless sensors, RADARs in its initial years. Before 1977,it was just offering one way communication i.e. half duplex but after the emergence of advanced mobile phone communication(1G based technology) duplexers were being employed for 2 way communication. The difference between simplex and duplex is as follows:-

Half Duplex: It refers to 1 way communication which means one has to wait for the other to complete his speech only then he will be able to speak .e.g. walkie talkie.

Full Duplex: It refers to as 2 way communication which allows communication in both directions. e.g. landline phone

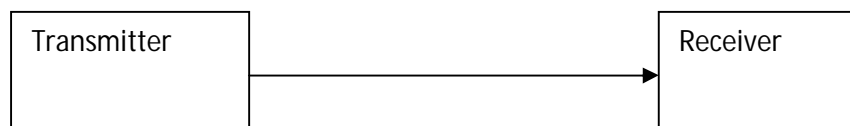

Figure 1.2 (a):Simplex

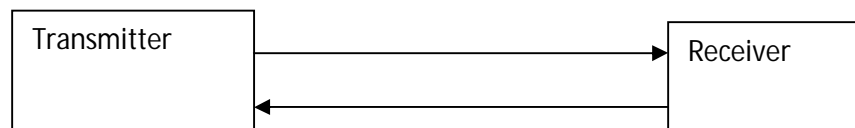

Figure 1.2(b): Full Duplex

Table 1.1: Comparison of Wireless generations [2]

parameters evaluation	Generation					
	1G	2G	2.5G	2.75G	3G	4G
Standard	AMPS	GSM/ cdmaone	GPRS	EDGE	UMTS	LTE WiMAX
Multiple access	FDMA	FDMA/ TDMA	FDMA/ TDMA	FDMA/ TDMA	CDMA	OFDMA/ SCFDMA
Transmission type	circuit switched	circuit switched	packet switched	packet switched	packet switched	packet switched
Maximum Throughput	4-5kbps	9.6 kbps	115 kbps	384 kbps	2.4 mbps	50 -100 mbps
Mode of Distribution	analog	digital	digital	digital	digital	digital
Frequency Band	890-960, 1710- 1880(Mhz)	890-960, 1710- 1880(Mhz)	890-960, 1710- 1880(Mhz)	890-960, 1710- 1880(Mhz)	1.8-2.4 (Ghz)	1.92-1.98, 2.11- 2.17(Ghz)
Features	Basic mobility	SMS, raoming	always on Internet	enhance GSM	Live calls, vid stream	IP based mobility

1.4 Characteristics of Wireless Channel:

A channel ideally should not contain more than one part of transmitted signal. If it does there would not be perfect reconstruction of signal as the signal consists of combination multiple versions due to reflection, refraction, attenuation or diffraction of original signals. The term is called fading which means the signal which arrives at the receiver is fluctuated form of the original signal. Here fluctuation refers to change in amplitude, frequency, phase and power of a signal caused due to interference between 2 or more versions of the transmitted signal. The channel in addition of fading further gets corrupted with noise which the conditions worse. Due to the effect of both fading and noise, the signal energy gets dissipated which means the we do not retrieve the complete message which was originally transmitted. Some message is lost or gets distorted.

Also, the relative motion between the base station and the mobile results in apparent shift in frequency. The shift in received signal frequency due to motion is called Doppler shift [2] which will be positive or negative depending on whether the mobile receiver is moving toward or away from the base station. Proper knowledge of all these phenomena is necessary for modeling of channel and to exploit the conditions.

1.5 Types of Fading:

Based on transmitter channel separation, fading can be divided into two parts-large scale fading and small scale fading[5].Large scale fading attributes for variation in signal strength over large transmitter separation distance. It tries to find out mean signal power attenuation or path loss due motion over large around transmitter or receiver

Small scale fading refers to the dramatic changes in signal amplitude and phase that can be experienced as a result of small changes in the spatial position between transmitter and receiver. Small scale fading characterizes rapid fluctuation of signal strength over short transmitter separations for short period of time. Small scale fading is caused by the multipath in the radio channel. One of the most important effects is the time dispersion caused by multipath propagation delays. Signals combine vectorally at the receiver antenna. Due to

multipath signals, each signal will experience difference in phase shift, attenuation and delay while travelling from transmitter to receiver.

1.6 Small Scale Fading

The type of fading experienced by a signal propagating through a mobile radio channel depends on the nature of transmitted signal. Different transmitted signals will undergo different types of fading. There are 2 different mechanisms in a mobile radio channel to describe the distribution in a channel. They are time dispersion and frequency dispersion. Time dispersion is a display of multiple pathways that spread the signal in time so that length of received signal is greater than length of transmitted signal. Time dispersion is one of the most important characteristics of the wireless channel which can be used for designing better systems which can adapt themselves to the changing nature of transmission medium. Frequency dispersion results from different frequency propagation at different speeds which arises mainly with the finite differencing method.

Fading due to multipath delay spread:

A) Flat Fading: In this, the channel characteristics are considered to be flat which means channel gain is constant and all the spectral components are passed through it. All the frequency components will undergo same amount of fading.

$$B_c \gg B_s \tag{1.6.1}$$

$$T_s \gg \sigma_\tau \tag{1.6.2}$$

where , B_c =bandwidth of channel

B_s =bandwidth of signal

T_s =symbol period

σ_τ =delay spread

B) Frequency selective fading: In this the coherence bandwidth (a statistical measure of the channel which passes all the spectral components with equal phase and gain) of the channel

is smaller than the bandwidth of the signal. So, the different frequency components present will undergo different amount of fading. ISI (Inter-symbol interference) will be introduced in the system as delay spread is greater than symbol period. The channels which undergo frequency selective fading are called wideband channels. In this,

$$B_c < B_s \quad (1.6.3)$$

$$T_s < \sigma_\tau \quad (1.6.4)$$

Based on Doppler spread, fading is also of 2 types:-

i) Fast fading: In fast fading channel, transmitted baseband signal changes at a rate which is slower as compared to the impulse response of the channel. In this, amplitude and phase of the channel does remain constant, they vary continuously due to the nature of fading. In this,

$$T_s > T_C \quad (1.6.5)$$

$$B_D > B_s \quad (1.6.6)$$

where , B_D = Doppler bandwidth

B_s = bandwidth of signal

T_s = symbol period

T_C = coherence time

ii) Slow fading: In this, transmitted baseband signal changes much faster than channel impulse response. Amplitude and phase of the channel widely remains constant. Slow fading is mostly cause by the process of shadowing (where hills or mountains comes in the path of transmitter and receiver and causes signal to be reflected several times before reaching to the destination).

In slow fading,

$$T_s < T_C$$

$$(1.6.7)$$

$$B_D < B_s$$

$$(1.6.8)$$

Slow fading has low Doppler spread as compared to fast fading. The velocity of the mobile and the baseband signaling tells whether the given signal will undergo fast fading or slow fading.

1.7 Fading Distribution

A) Rayleigh Distribution: When there is no line of sight propagation between transmitter and receiver, then fading distribution is Rayleigh distribution [5]. Rayleigh fading is used as a model for tropospheric and ionospheric signal propagation. Rayleigh fading is basically a small scale effect. The pdf of Rayleigh distribution function is:

$$p(r) = \begin{cases} \frac{r}{\sigma^2} \exp\left(-\frac{r^2}{\sigma^2}\right) & (0 < r < \infty) \\ 0 & (r < 0) \end{cases} \quad (1.7.1)$$

where, σ = the rms value of the received signal

$$\sigma^2 = \text{time average of the received signal}$$

B) Rician fading distribution: When line of sight exists between transmitter and receiver, then the small scale fading distribution is Rician. Rician fading is mostly caused by partial cancellation of radio signal by itself. The Rician distribution is given by

$$p(r) = \begin{cases} \frac{r}{\sigma^2} \exp\left(-\frac{r^2}{\sigma^2} - \frac{A^2}{\sigma^2}\right) I_0\left(\frac{rA}{\sigma^2}\right) & A > 0, r > 0 \\ 0 & (r < 0) \end{cases} \quad (1.7.2)$$

where, A = peak amplitude of the dominant signal,

$I_0(\cdot)$ = modified Bessel function of first order

CHAPTER 2: 3GPP LTE PHYSICAL LAYER

2.1 Introduction to 3GPP

Third generation partnership project (3GPP [6]) is an alliance between collection of persons of telecommunication associations which are usually referred to as organizational partners. Their initial aim was to make third generation system applicable worldwide. Third generation partnership project calibration encrypts various radio and core networks. It was started back in 1998 based on global system for mobile. Its another version 3GPP2 started shortly thereafter which was based on CDMA. The third generational partnership project links 6 formally acknowledged standardization governing bodies which have decided to work collectively for the yielding of evolved 3rd generation and beyond communication system specifications. The means for this collective activity has been allowed in the form of partnership project. The collaborators have accorded to cooperate in the yielding of world wide applicable proficient stipulation and proficient reports for a developed 3rd generation and outside mobile system on evolved 3GPP core networks and the radio access technologies that they support. They have further agreed to collaborate in the upkeep and growth of the global system for mobile proficient stipulation and proficient reports which includes 2.5G technology called general packet radio service (GPRS) and 2.75G technology called enhanced data rates for GSM evolution (EDGE). The further development of International mobile system should be done in an independent way.

The design also encapsulates mobile network technologies and service potentialities including quality of service, work on codecs, service, thus catering accompanying system stipulation. The stipulation also allows caws for non radio access to the core networks and Wi-Fi networks. The third generation partnership projects stipulations and works are partly ridden by member companies and working groups. They makes use of latest working methods, assures that decision making takes at the lowest level in the most effective manner, uses minimal production time for proficient stipulation and proficient reports from creation to commendation. Their scope lies within limits of International Telecommunication union. Their headquarters is located at Sophia Ant polis in the region of France.

2.1.1 History of 3GPP

The initial idea came from a strategic opening between Nortel network AT&T (American Telecommunication in Texas). In 1998, Norton developed a vision called Internet Protocol which is basically a cell web which gave an idea [7] to build Wireless Internet. The companies from United States took a strong interest. In 1999, AT&T started a company to develop a standard which was initially called 3GIP (3rd generation internet protocol). AT&T and British telecom formed alliance to facilitate global roaming. Due to the popularity of GSM in European countries it was taken as the basis of 3GIP. Further newer versions of GSM like GPRS (general packet radio service) and EDGE (enhanced data rates for GSM evolution) were also developed. Several countries began to show their interest in 3GIP. Among those were Japan, China, Korea, and India. Then, 3GIP converted into 3GPP (3rd generation partnership project) for deploying and developing next generation wireless system in the effective way possible.

2.1.2 Organizational Partner:

There are basically 6 partners of 3GPP. They are:

Table 2.1: Organizational Partners [6]

COUNTRY	NAME OF ORGANIZATION
EUROPE	European Telecommunication Standards Institute
JAPAN	Association of Radio Industries and Business
USA	Alliance for Telecommunication Industrial Solution
CHINA	China Communication Standards Association
KOREA	Telecommunication Technological Association
JAPAN	Telecommunication Technological Committee

2.1.3 Structure of 3GPP

3GPP consists of:

1. Project Co-ordination Group

2. Technical Specification Group: This group consists of:

a) Radio and Access Network: Radio and access network specifies the UTRAN and E-UTRAN. It is composed of 5 working groups.

b) Service and system aspects: System aspects (SA) specifies the service requirements and overall architecture of the 3GPP system. It is also responsible for the coordination of the project. It is composed of 5 working groups.

c) Core network and terminals: Core terminals (CT) specifies the core network and terminal parts of 3GPP .It includes the core network terminal layer 3 protocol. It is composed of 5 working groups.

d) GSM EDGE radio access networks: Also known as GERAN. It specifies the GSM Radio technology, including GPRS (general packet radio service) and EDGE (enhances data rate for GSM evolution).IT consists of 3 working groups.

2.1.4 Scope and Objectives of 3GPP

The main objective of 3GPP is that it should be able to prepare, approve and maintain the required set of proficient stipulations and proficient reports for a developed 3rd generation and mobile system which shall include:

1. Developed Universal Terrestrial radio access network (including frequency division duplex and time division duplex method).

2. Organization and service aspects.

3. 3GPP central network and roots which includes mobility management, roaming and utilization of relevant internet protocols.
4. To be able to supply a high degree of persistence in the arising system, granting existing system to be braced one-self succeeding stipulations and functionality providing higher data rates, quality of service and cost efficiencies;
5. To be able to reduce complication and atomization of technologies.
6. Stipulations and standards for the GSM core network should be common to the largest level.
7. To avoid duplication of work.
8. To promote their members to provide licenses on fair, sensible terms and considerations on a non-preferential policies.
9. To make the scheme backward and forward compatible where-ever possible to make sure that the functioning of user equipment is not disturbed.
10. To make the whole process course driven.
11. To make the service requirements from user point of view.
12. To define an architecture to meet the service requirements.
13. To define an implementation of the architecture by specifying protocols.

Above 3GPP technologies GSM/EDGE and wideband code division multiple access are currently serving 85-90% of the mobile users worldwide .A majority number of CDMA users have already turned to GSM or GSM based technologies for easier communication. Each release of 3GPP incorporates hundreds of individual standard documents, each of which may have been through many revisions. Current 3GPP standards incorporate the latest revision of 3GPP standards. Future wireless technologies like LTE will be built on the large base of 3GPP technology.

2.2 LTE Overview

LTE stands for long term evolution. LTE [8] along with WiMAX are adopted for fourth generation wireless. It is a standard for wireless data communications technology and an evolution of the GSM/UMTS standards. LTE is the upgrade path for carriers with both GSM/UMTS and cdma2000 networks. It was launched by 3rd generation partnership project which was started back in 2004. It took approximately 5 years to deploy the system commercially. The basic concentration was to make the system with more capacity so as to add more users within a given bandwidth. A further goal was the restyle and reduction of the network architecture to an IP-based system with significantly reduced transfer latency compared to the 3G architecture. The LTE system is not compatible with 2G and 3G networks, so that it must be operated on a different wireless spectrum. The multiple access scheme in LTE downlink uses Orthogonal Frequency Division Multiple (OFDMA) and uplink uses Single Carrier Frequency Division Multiple Access (SC-FDMA). The uplink single carrier solution is designed to make the system power efficient and the downlink multiple carrier solution is designed to increase the spectrum efficiency by providing orthogonality between the users and reducing the interference. The downlink can also use resource blocks throughout the system. A few reasons can be identified causing LTE development: the need for lower cost data delivery, the need of a system with more capacity so as to meet the needs of increasing number of users and competition with other wireless technologies. WiMAX is a contender for fourth generation wireless system and it is strong rival of 3GPP LTE system. WiMAX has been adopted by IEEE and referred to as IEEE 802.16. It also promise higher data rates. Therefore LTE should exceed the competition to remain alive in the market by providing better features.

An enhanced version of LTE called LTE advanced was also submitted as a candidate of fourth generation wireless system after meeting the requirement of the IMT advanced standard. One of the important LTE advanced benefits is the ability to take advantage of advanced topology networks; optimized networks with a mix of macro-cells with a low power node. It further improves capacity and coverage and ensures user fairness.

2.2.1 Targets of LTE

LTE is anticipated to become the first truly global mobile phone standard with different LTE frequencies and bands deployed by different countries. As to become a global standard, LTE system should utilize the spectrum more efficiently so as to reduce the number of base stations. Its peak user throughput should be greater than greater than high speed packet access technology. It should be about 100 Mbps in downlink and 50 mbps in uplink. Latency and PAPR should be reduced to improve the end user performance and power consumption respectively.

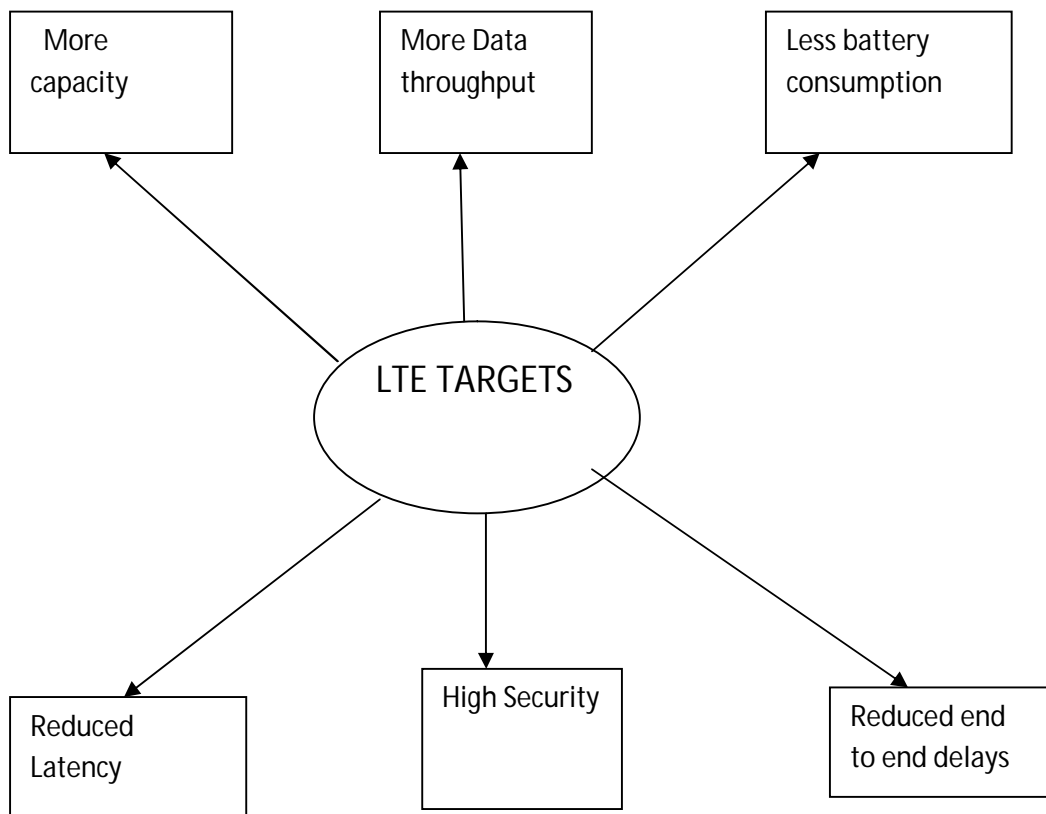

Figure 2.1: Targets of LTE [9]

2.2.2 Features of LTE

LTE is a standard for wireless data communication technology and an evolution of GSM/UMTS standards. It is a strong contender of 4G network. Its goal is to make the system architecture simpler and its features are:

1. It uses OFDMA in the downlink and SCFDMA in the uplink.
2. Provides peak throughput of 100 Mbps in downlink and 50 Mbps in uplink.
3. End to end delays are reduced.
4. Low battery consumption in the uplink.
5. Uses packet switched domain.
6. Round trip time is below 10 ms.
7. Networks are self optimized.
8. Flexible use of spectrum.
9. Future improvement for enhanced VoIP support.
10. Support for larger bandwidth.
11. Lower connection set up time as compared to previous access technologies.
12. Simplified architecture consisting only of eNodeBs.
13. Support for multicast broadcast single frequency network.
14. Support for inter operation and co-existence with standards like GSM and UMTS.
15. Support for both FDD and TDD.

2.3 LTE Radio Protocols

Radio protocols are used to set up and configure the radio bearer. Radio protocols above the physical layer (layer 2) are medium access control , radio link control and packet data and the convergence protocol.

Brief explanation of protocol architecture is as follows:

The physical layer is used to carry the transport channels provided by the MAC layer. The MAC layer offer the logical channels to the RLC layer. The logical channels tells us about type of data to be transmitted. Layer 2 provides radio bearers which carries RRC signaling

messages. MAC, RRC and PDCP are all located in enodeB.

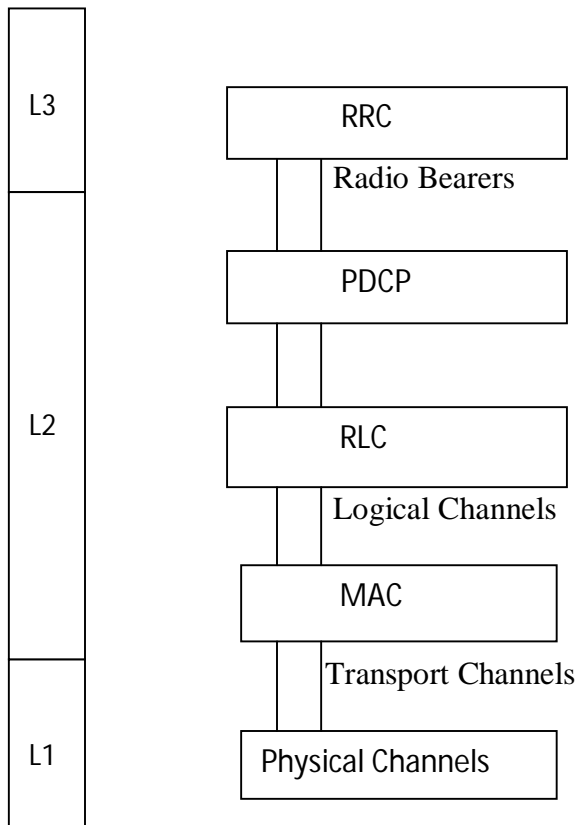

Figure 2.2: LTE radio protocol stack [10]

1. MAC: MAC stands for medium access. This layer maps the logical channels to transport channels. It also provides the traffic volume experience.
2. Logical channels: The MAC layer provides the service to the RLC layer.
3. RLC layer: It transfers the PDUs received from higher layer. It also handles the protocol errors.
4. Packet data convergence protocol (PDCP): It is located above the RLC layer of the user plane. It helps in integrity protection, verification, ciphering and deciphering of the user plane.
5. Radio resource control (RRC): They cover major part of the control information. The redundancy is very less in the messages. It provides establishment and configuration.

2.4 LTE physical layer

The LTE physical layer [11] is packet based on dynamically allocated shared resource rather than user specific resource allocation. The layer plays a key role in defining the capacity of a system and to make a standard so as to compare it with other systems. The 3GPP LTE term used for the base station used is eNodeB where e refers to evolved. For WCDMA BTS term we use eNodeB. The physical layer helps us to provide dynamic resource assignment both for data rate and for resource division.

2.4.1 LTE physical channels for downlink

The function of physical channels [12] is to give information from upper layers of the LTE stack. Physical channels which are supported by LTE in downlink are:

- a) Physical Broadcast Channel (PBCH): Features like paging and control signaling information are carried with the help of physical broadcast channels. Sub-frames are being used for mapping of channel transport block [13].
- b) Physical Control Format Indicator Channel (PCFICH): OFDM symbols are being contained in this channel which are transmitted in every sub-frame.
- c) Physical Downlink Control channel (PDCH): Control signaling information is being controlled by this channel.
- d) Physical Downlink Shared Channel (PDSCH): Services like multimedia and transportation of data are carried out with the help of this channel.

2.4.2 LTE Downlink Physical Signals

Assigned resource elements are being used by physical signals in the physical resource. The 2 types of signals used are:

1. Reference signals: Pseudo random numerical sequence and an orthogonal signal when used collectively forms the basis of reference signals being inserted in the 1st and 3rd OFDM symbol of every slot [14].

2. Synchronization signals: To know about the identification of cells and synchronization of signals, we use synchronization signals.

2.4.3 LTE Downlink Transport Channels

Transport channels which are used act as an interface between medium access and the physical layer.

Transport channels [14] used are :

1. Broadcast channel (BCH): Broadcast channel helps in providing synchronization for a new mobile within cellular network and is also used to broadcast the information such as network identity and congestion and availability of the channel.
2. Downlink Shared channel (DL-SCH): Information of user data is carried for point to point communication. It supports dynamic resource allocation.
3. Paging channels: It is basically a control channel which provides paging signals from the base station to all mobile in the cell.

2.4.4 Mapping of Transport to Physical channel:

Transport channels helps to transport data between MAC and physical layer. PDSCH is used to map PCH while downlink shared channel is mapped on physical downlink channel.

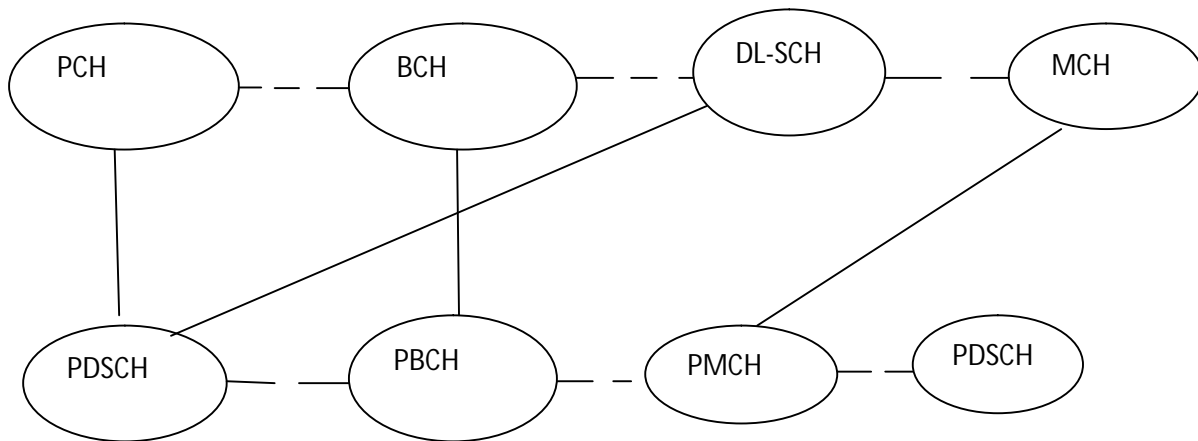

Figure 2.3 Mapping of transport to physical channel [14]

2.4.5 LTE Physical layer processing in downlink:

The table which shows how the physical layer processes in downlink is as follows:

Table 2.3: Physical layer processing (downlink) [14]

CRC insertion
Channel coding
HARQ processing
Channel
Scrambling
Modulation
Layer mapping
Antenna mapping
Resource management

1. CRC insertion: Cyclic Redundancy Check is added at the beginning of the transport blocks so as to detect residual errors.
2. Channel Coding: It is used to detect and correct errors by using turbo codes.
3. HARQ processing: It is used to extract the bits from the blocks of code bits delivered by the channel encoder.
4. Scrambling: It is used to utilize the processing gain provided by the channel code.
5. Modulation: To encrypt the data into complex bits, we use modulation. Modulation like QPSK, 16 QAM and 64 QAM is performed on the scrambled bits which results in the generation of modulation symbols.

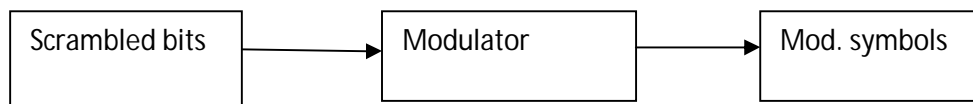

Figure 2.4: Downlink Modulation

6. Antenna mapping: To map the output bits to various antenna ports, we use antenna mapping.
7. Resource block mapping: Maps the output symbols to the resource elements of the resource blocks

2.5 Multiplexing used in downlink of 3 GPP LTE:

Due to high spectral efficiency and robust transmission in presence of multipath fading, OFDMA has been selected as basic multiplexing scheme for downlink in LTE systems. The LTE physical layer specifications are designed to deal with the bandwidths from 1.25MHz to 20MHz.

2.5.1 Introduction to OFDM

The idea of using parallel data transmission and frequency division multiplexing was developed in the mid of 1960s [15]. In a parallel data system, the block is divided into sub-blocks which have no cross correlation with each other and each sub block is modulated with different symbol and then the sub blocks are frequently multiplexed to avoid spectral overlap of channels to eliminate inter-channel interference.

OFDM stands for orthogonal frequency division multiplexing is a special case of multicarrier transmission. Here a single data stream is spitted into a number of sub-carriers. The word orthogonal implies that sub carriers used have no cross correlation with each other. In a multicarrier system, a single interferer cannot cause the entire link to fail but only a few subcarriers will be affected.

The development of OFDM can be divided into 3 parts consisting of frequency division multiplexing(FDM), multicarrier transmission and parallel transmission. FDM involves assigning non overlapping frequency channels to different signals and guard band is left between channels to avoid overlapping. These signals are modulated individually and transmitted over the channel. At the receiver end, these are de-multiplexed and demodulated to obtain the original signal. OFDM is a special of multicarrier transmission in which data is

divided into sub carriers which are made independent to each other by placing the carriers at the nulls in modulation spectra of each other.

OFDM is a parallel transmission scheme where high data stream is divided into a set of low data sub streams. Bandwidth of sub carriers is small compared to the coherence bandwidth making individual sub-carriers experience flat fading.

In telecommunication, parallel communication conveys multiple binary digits simultaneously whereas serial communication conveys single bit at a time. Parallel communication uses more than one electrical conductor at the physical layer to convey bits whereas single channel use one electrical conductor at physical conductor to convey bits. So if both channels are used at same clock period, parallel channel will be faster due to more number of conductors.

2.5.2 History of OFDM

The first work on OFDM scheme goes back to 1966 when Robert W.Chang published his pioneering work on the synthesis of band limited orthogonal signals for multi channel data transmission. A patent was issued on his work [16].A new scheme of transmitting signals simultaneously over a band limited channel was presented. The basic idea of OFDM was to split the frequency selective channel into small number of narrow flat sub channels. There have been a lot of contributions throughout the development of OFDM. In 1971 Weinstein and Elbert [17] used digital fourier transform to generate sub carriers. This scheme replaced analog method with digital method. Earlier bank of coherent modulators were used for generating sub carriers. This method was cost ineffective and complex. Now by making use of DFT, subcarriers are produced which are orthogonal to each other.

Another achievement came in 1980 when Pelez and Ruiz solve the orthogonality problem by introducing cyclic prefix (CP) [18]. In cyclic prefix, last part of OFDM signal is attached to the first part which converts linear convolution into circular convolution which ensures orthogonality and eliminates ISI between sub carriers as long as CP remains longer than the impulse response of the channel. The receiver is configured to discard the cyclic prefix signals. The drawback of adding CP is that spectral efficiency is reduced as more

number of bits are produced. Cyclic prefix is often used in conjunction in order to retain sinusoid properties in multipath channels.

2.5.3 Transmission and Reception in OFDM system

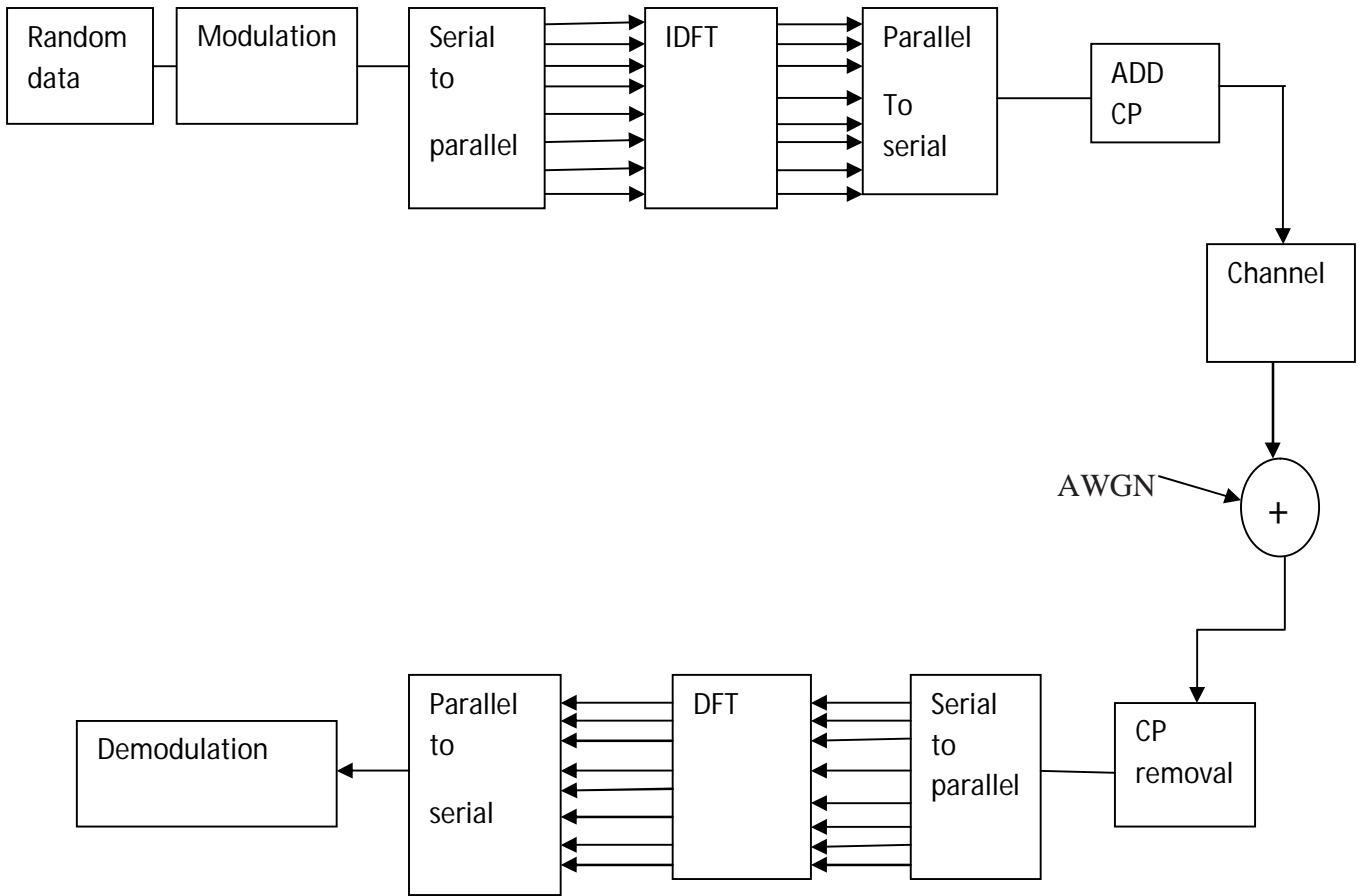

Figure 2.5: OFDM Block Diagram[19]

1) The IDFT and the DFT are used for, respectively, modulating and demodulating the data constellations on the orthogonal SCs. These signal processing algorithms replace the banks of I/Q-modulators and demodulators that would otherwise be required.

2) The Cyclic Prefix or Guard Interval is a periodic extension of the last part of an OFDM symbol that is added to the front of the symbol in the transmitter, and is removed at the receiver before demodulation.

The cyclic prefix has 3 important benefits:

- a) The cyclic prefix acts as a guard interval. It eliminates the inter – symbol interference from the previous symbol.
- b) It acts as a repetition of the end of the symbol thus allowing the linear convolution of a frequency – selective multipath channel to be modeled as circular.
- c) The system becomes periodic.

2.5.4 Advantages of OFDM

- a) Due to the fact that OFDM symbols are overlapping, there is an increase in spectral efficiency of the system. In less bandwidth, a lot of data can be accommodated as bandwidth is a very limited resource.
- b) Due to increase in symbol duration, there is a reduction in delay spread. Addition of guard band almost removes the ISI and ICI in the system.
- c) Conversion of the channel into many narrowly spaced orthogonal sub-carriers render it immune to frequency selective fading.
- d) OFDM is mathematically efficient by using FFT techniques to implement the modulation and demodulation functions instead of bank modulators used earlier.
- e) Maximum likelihood decoding with reasonable complexity can be used with OFDM systems.
- f) It is less sensitive to sample timing offsets than single carrier systems.
- g) It provides good protection against co channel interference.
- h) Symbols which are lost in the process can be recovered in OFDM systems by using interleaving and channel coding techniques.

2.5.5 Major Challenges in OFDM

- a) These systems are highly sensitive to Doppler shifts which affect the carrier frequency offsets, resulting in ICI.
- b) High PAPR: When the number of sub-carriers with the same phase add up add up coherently, they tend to give a high peak to power ratio which decreases the efficiency of power amplifiers which results in low power efficiency.

c) The use of cyclic prefix in OFDM reduces the spectral efficiency. CP is basically an extension of OFDM signal.

2.5.6 Applications of OFDM

Orthogonal frequency-division multiplexing (OFDM) effectively mitigates inter-symbol interference (ISI) caused by the delay spread of wireless channels. Therefore, it has been used in many wireless and wireline systems [19] and adopted by various standards

a) DAB: Current FM system has nearly reached its limits of further development in its technology. DAB which stands for digital audio broadcasting offers certain advantages over FM like excellent sound quality, no quality deterioration due to multipath propagation. OFDM is used for transmission as it can avoid interference due its orthogonality nature.

b) ADSL: ADSL stands for asymmetric digital subscriber link is a type of DSL which provides faster data transmission. The benefits of OFDM like lower attenuation at high frequency and low narrow band interference are the main reasons of using it for transmission purposes in ADSL.

c) WiMAX: WiMAX which stands for worldwide interoperability for microwave access is a 4G technology used for delivering high data rates with high spectral efficiency. OFDMA is used in the uplink and downlink of WiMAX.

d) Powerline Technology: Powerline communication is used to carry on a conductor for electric power distribution. OFDM is used by powerline devices to extend digital connection through power wiring.

e) Wireless PAN: OFDM is used in WiMedia for high speed personal area networks in the 3.1-10.6GHz ultra wideband spectrum.

2.6 Uplink of 3GPP LTE

For uplink, SC-FDMA [20] is selected as a basic multiple access scheme for LTE physical layer. SC-FDMA is also a multi-carrier scheme that re-uses many of the functional blocks of

OFDM. The main advantage of SC-FDMA is its low PAPR which is a useful parameter for uplink.

2.6.1 LTE uplink channels

The channels [21] which are used in uplink of LTE are: a) Physical random access channel (PRACH): It uses random access preamble which consists of sequence length. Zad-off chu are used for generating random access preamble and b) Physical uplink shared channel (PUSCH):The basic function of PUSCH is to carry user data for transmission.

2.6.2 Signals used in LTE uplink

The signals used are: Reference signals: These are transmitted in order to facilitate coherent demodulation and frequency selective fading. They are normally based on Zad-off Chu sequences; and Random access preamble signals: Upper layers and physical layer of the LTE stack are included in random access procedures

2.6.3 LTE Uplink Transport channels

They basically act as an interface between physical and upper layers of LTE stack. Uplink transport channels used are as follows:

1. Uplink Shared Channel (UL-SCH): It provides support for beamforming and hybrid ARQ.
2. Random Access channel (RACH): It carries minimal control information required for transmission.

2.6.4 Mapping of Uplink Transport channels to Uplink Physical channels

Uplink transport channels are mapped with physical channels.Flow diagram showing mapping of transport channels to physical channels is as follows:

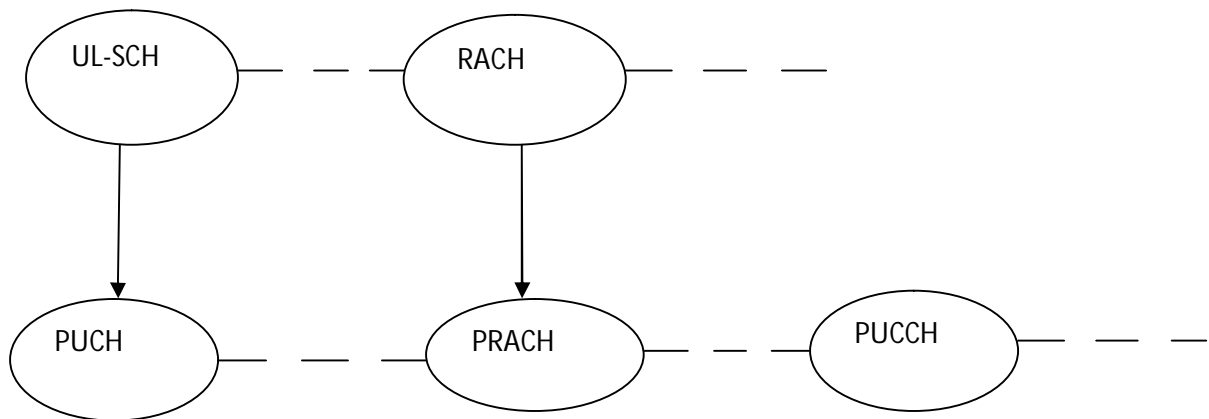

Figure 2.6: Mapping of Uplink transport and physical channel [14]

where, UL-SCH=uplink shared channel, RACH=random access channel

2.6.5 Uplink Physical layer processing

It is quite similar to downlink processing, however, uplink transport channel did not define transmit diversity.

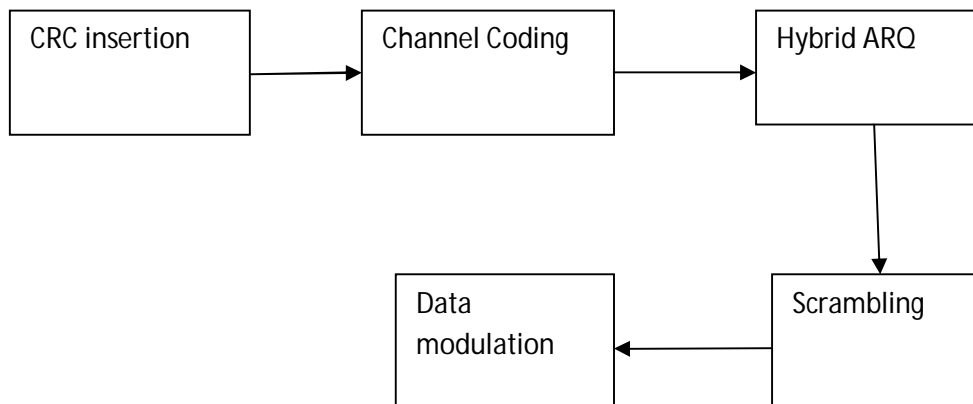

Figure 2.7: To SCFDMA modulation including mapping of assigned frequency response

1. CRC-insertion: Cyclic redundancy check is added so as to allow the receiver to detect residual errors from the decode transport block

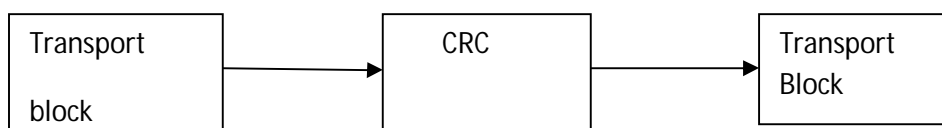

Figure 2.8: CRC insertion per transport block

2. Channel coding: It is used to correct and detect errors. Normally turbo codes which are forward error detection codes are used.
3. Hybrid ARQ functionality: It is important to extract the exact bits from the blocks of code bits. This is done by hybrid ARQ functionality.
4. Scrambling: It means to jump. It is used to make the signal random so that the signal become unpredictable and unbiased for accurate timing recovery. It is also used for cryptographic techniques as it inverts the signal and makes it difficult to intercept.
5. Data modulation: To convert the bits coming from scrambler in complex modulation symbols we use modulator. Normally we use modulation techniques like QPSK, 16 QAM and 64 QAM.

2.7 Multiplexing used in Uplink of LTE

Single Carrier Frequency Division Multiple Access (SC-FDMA) is a promising technique [22] for high data rate uplink communication and has been adopted by 3GPP for its next generation cellular system, called Long-Term Evolution (LTE).

2.7.1 SC-FDMA: An Introduction

SC-FDMA is a modified form of OFDM with similar throughput performance and complexity. This is often viewed as DFT-coded OFDM where time-domain data symbols are transformed to frequency-domain by a discrete Fourier transform (DFT) before going through the standard OFDM modulation. Thus, SC-FDMA inherits all the advantages of OFDM over other well-known techniques such as TDMA and CDMA. The major problem in extending GSM TDMA and wideband CDMA to broadband systems is the increase in complexity with the multipath signal reception. The main advantage of OFDM, as is for SC-FDMA, is its robustness against multipath signal propagation, which makes it suitable for broadband systems. SC-FDMA brings additional benefit of low peak-to-average power ratio (PAPR) compared to OFDM making it suitable for uplink transmission by user-terminals.

2.7.2 SC-FDMA Transmitter and Receiver

SC-FDMA uses an additional M-point DFT stage at transmitter and an N-point IDFT stage at receiver. The basic block diagram of SC-FDMA transmitter is shown below. The input to transmitter is a stream of modulated symbols.

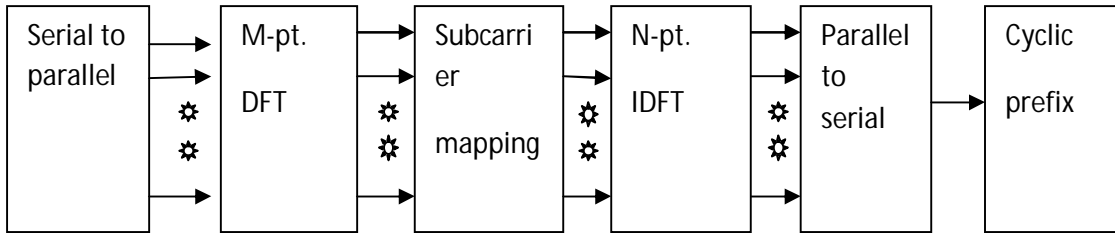

Figure 2.9: SC-FDMA transmitter [22]

The process transmission of SC-FDMA scheme is almost similar to OFDMA. In telecommunication, serial communication is the process of sending data sequentially (one bit at a time). This differs from parallel communication in such a way that in parallel communication, several bits are sent as a whole on a link with several parallel channels simultaneously.

The performance of SC-FDMA in relation to OFDMA has been the subject for various studies. SCFDMA advantage of low PAPR gives priority over OFDMA in uplink wireless transmission of future generation where transmission efficiency is of utmost importance. SC FDMA in other words can be interpreted as a linear pre-coded system in the sense that an additional DFT block is used ahead of IDFT block along with the sub carrier mapping block.

In SCFDMA the data is mapped into signal constellation according to QPSK, 16 QAM and 64 QAM modulation depending upon the channel conditions. After modulation, these signals are passed through serial and parallel converter followed by a DFT block which produces discrete frequency domain representation of QPSK/QAM symbols. Pulse shaping (optional) is followed by DFT block to shape the output signal from DFT. Bandwidth extension occurs after pulse shaping. Subcarriers coming from DFT are then mapped according to subcarrier mapping method. After mapping, these subcarriers are passed

through IDFT for time domain conversion. The output results in DFT and IDFT operations virtually cancel out each other. The sub carrier mapping plays an important role in transmitter of SCFDMA. It maps each of the M DFT output on a single subcarrier out of N subcarriers, where N is the total number of subcarriers for available bandwidth.

The subcarrier mapping is achieved by 2 methods-localized sub carrier mapping and distributed sub carrier mapping [22]. Modified form of DFDMA called IFDMA [23] (interleaved frequency division multiple access) is also used. In localized sub carrier mapping the modulation symbols are assigned to M adjacent sub carriers whereas in distributed mode, the symbols are uniformly placed across the whole channel bandwidth. Localized sub carrier mapping is also referred to as localized SCFDMA (LFDMA) and distributed sub carrier mapping is referred to as distributed SCFDMA (DFDMA). In transmitter, zero amplitude is assigned to the unoccupied subcarriers by IDFT in both the modes of sub carrier mapping. If M is the number of subcarriers, Q is the number of users and N is the subcarriers allocated per users, then $Q=M*N$ with equidistance between subcarriers is referred to as interleaved FDMA. IFDMA [15] is much more efficient in reducing PAPR than other methods as the signal in IFDMA can be modulated without using DFT and IDFT. But IFDMA has the drawbacks the higher bit error rate and improper channel scheduling as compared to LFDMA.

DFDMA distributes M DFT outputs over the entire band of total N subcarriers with zeros filled in N subcarriers. Pulse shaping is usually applied after IFFT. IFDMA will have a trade-off between excess bandwidth and PAPR performance since excess bandwidth increases as the roll off factor becomes larger.

The raised cosine filter is a filter frequently used for pulse shaping in digital modulation due to its property to minimize intersymbol interference. The raised cosine filter is an implementation of a low pass Nyquist filter. Nyquist filter has the property of eliminating ISI as its impulse response is zero for $nT=0$ where n is an integer and it is not equal to zero.

SC-FDMA Receiver is almost same as conventional OFDMA with additional blocks of subcarrier de-mapping, IDFT and optional shaping filter. This filter corresponds to the spectral shaping used in the transmitter. The subcarrier de-mapping of M-mapped subcarrier results N-discrete signals. In the end, IDFT converts the SC-FDMA signal to the signal constellation. .

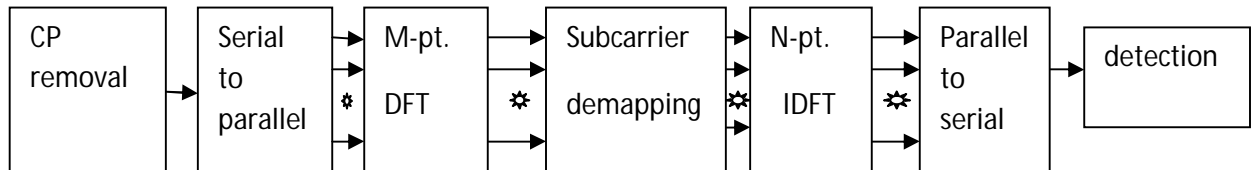

Figure 2.10: SC-FDMA Receiver [22]

2.7.3 Advantages of SC-FDMA

1. Low PAPR
2. Low sensitivity to carrier frequency offset
3. Less sensitive to non linear distortion and hence, it allows the use of low-cost power amplifiers
4. Greater robustness against spectra null.

2.7.4 Drawbacks in SC-FDMA

1. Higher receiver complexity.
2. Additional DFT processing increases mobile station complexity

2.7.5 Applications of SC-FDMA

SC-FDMA has drawn great attention as an attractive alternative to OFDMA, especially in the uplink communications where lower peak-to-average power ratio (PAPR) greatly benefits the mobile terminal in terms of transmit power efficiency and reduced cost of the power amplifier.

CHAPTER 3: LITERATURE SURVEY

3.1 Introduction to PAPR

OFDM is a multicarrier modulation technique which provides high spectral efficiency, resistance to multipath fading and less vulnerability to echoes. These advantages of OFDM make it widely applicable in wireless communication system. But the main problem one faces while implementing OFDM system is its high peak to power ratio commonly referred to as PAPR. An OFDM signal consists of a number of independently modulated subcarriers which when added up coherently give a large PAPR. When M signals are added with the same phase, they produce a peak power which is M times the average power. The peak power refers to the power of a sine wave with amplitude equal to the maximum value. A large PAPR increase the complexity of the A/D converter and causes reduction in the efficiency of the RF power amplifier which in reduces battery lifetime. All the advantages of OFDM can be outweighed by high PAPR value. Thus it is important to have research on PAPR problem to fully enjoy the benefits of OFDM system.

There are number of techniques to reduce PAPR. Some of them are clipping and filtering, coding, partial transmit sequence (PTS), tone reservation, selected mapping (SLM). These techniques achieve PAPR reduction at the expense of transmit signal power increase, bit error rate (BER) increase, data rate loss, computational complexity increase, data rate loss, complexity at transmitter and receiver and so on.

3.2 Complimentary Cumulative Distribution function (CCDF)

The Complimentary Cumulative Distribution is one of the most regularly used parameters to measure the amount of PAPR of a specific system .The CCDF of the PAPR denotes the probability that the PAPR of a data block exceeds a given threshold .From the central limit theorem ,the real and imaginary parts of the time domain follow Gaussian distribution. The amplitude of a multicarrier signal has a Rayleigh distribution and the power distribution becomes a central chi-square distribution.

3.3 PAPR Reduction Techniques

PAPR reduction techniques vary according to the needs of the system and are dependent on various factors. PAPR reduction capacity, increase in power in transmit signal, loss in data rate, complexity of computation and increase in the bit-error rate at the receiver end are various factors which are taken into account before adopting a PAPR reduction technique of the system.

3.3.1 Clipping and Filtering

Amplitude clipping [24] is considered as one of the simplest techniques for PAPR reduction. A threshold is set so as to limit the peak amplitude of system. Signals above threshold are clipped (causing reduction in high peaks) and the remaining are permitted to pass. Mathematical equation of clipping is:

$$C(x) = \begin{cases} X, & |X| < A \\ A, & |X| > A \end{cases}$$

where,

$C(X)$ = the amplitude value after clipping.

X = the initial signal value.

A = the threshold set by the user for clipping the signal.

The drawback of classical clipping includes in band and out of band distortion. Spectral efficiency is also affected. Out of band radiation can be reduced by filtering but peak regrowth takes place after filtering. The selection of a filter is a cumbersome process. So due to all of these problems, clipping system is used quite less now.

3.3.2 Non Linear Companding Transform

Companding [25] is the alternative method used for clipping. μ -law companding which is the non linear companding transform is mostly used. It enlarges signals which have small

amplitude and the peak signals are kept unchanged. Non linear companding is a special case of clipping.

The main differences between the clipping and non linear companding transform are:

1. Signals after clipping cannot be recovered at the receiver whereas non linear companding transform compand OFDM signal by using strict monotone increasing function which makes them recover by using inversion of the non linear transform.
2. Non linear companding expands the small signals and compress the large signal whereas clipping do not touches the small signals.

3.3.3 Block Coding Techniques

Coding [26] is also a method to reduce the PAPR. This method selects the codewords which reduces the PAPR. The drawback of this method is that the exhaustive search method is used to find the suitable codewords which makes this method time consuming.

3.3.4 Selected Mapping technique

In the SLM technique, the transmitter generates a set of different data blocks out of which a particular data block with the lowest PAPR [27,28] is chosen. This technique suffers from the problem of exhaustive search and transmission of side information along with the chosen information. It is a distortion-less method.

3.3.5 Partial Transmit Sequence

This method is basically a modification of SLM method .It is based on scrambling technique. The data block is divided into disjoint sub blocks. Blocks are divided with independent rotation factor. The rotation factor [29] generates time domain data with lowest amplitude. The performance of this method is better than SLM method because of differential method as no side information is generated.PTS method suffers from high computational complexity and the PAPR reduction is not that much.

3.3.6 Tone reservation

Tone reservation method [25] is an efficient method to reduce the PAPR of a multicarrier signal. This is based on adding a data block dependent time domain signal to the original multicarrier signal to reduce its peak. The benefit of adding time domain signal is that it can be easily computed at the transmitter.

3.3.7 Tone Injection

The main idea is to increase the constellation [30] so that the points in the actual constellation can be embedded in the actual constellation. Now to more space left in the expanded constellation, we can now have more degrees of freedom to reduce the PAPR. The above method is called tone injection as it is equivalent to injecting a tone of appropriate frequency and phase in the multicarrier signal. Power level increases in this method due to injection of tones.

3.3.8 Active Constellation Technique

Active Constellation [30] is a method which is quite similar to tone injection method. In this method, the outer signal constellation points are extended towards outside of the actual constellation to reduce the PAPR. There is no loss of data rate and no side information is required. The main drawback includes increase in signal power for the data block.

3.3.9 Interleaving Technique

It is a technique quite similar to SLM technique. In this method a set of inter-leavers [30] are used instead phase sequences to reduce the PAPR. Inter-leavers are used to produce permuted data blocks from the same data block. The amount of reduction in PAP depends upon the number of inter-leavers used.

3.3.10 DFT Spreading

In this method, prior to IDFT in the OFDM block diagram, DFT block is added. The DFT-IDFT combination will eventually cancel each other out, so the system becomes equivalent to SC-FDMA with a lower PAPR as compared the OFDM.

In 1971, Weinstein [17] proposed a method to generate OFDM signal with the help of discrete fourier transform. Banks of subcarrier oscillators which were earlier used for modulation purposes are now completely replaced by digital implementation. Serial to parallel conversion is done much effectively and the carriers generated have no cross correlation with each other die to the nature of discrete fourier transform.

In 2002 Armstrong [33] proposed a paper in his paper has shown the effects of clipping and filtering on the functioning of OFDM. Clipping means to limit the signal amplitude. Clipping the signal directly results in noise so oversampling is done to remove the aliasing problem. Clipping also results in band and out band radiation. Out of band radiation can be reduce by filtering but in band radiation is very hard to remove which ultimately makes clipping and filtering a disadvantageous method.

In 2009 Jha *et al* [34] has proposed a method based on clipping and amplification. Clipping can be performed in 2 ways-one is to clip the complex envelope of OFDM signal and the other is to clip the in-phase and quadrature phase signal independently. In the first method i.e. clipping the complex envelope, a threshold value is fixed. Above the threshold, signals are clipped and signals having low amplitude are amplified. In the second method, the inphase signals and quadrature phase signals are clipped independently above threshold value.

Salvator *et al* [35] discussed the technique of soft clipping for PAPR reduction in OFDM system. Soft clipping method has an edge over conventional hard clipping that it has non zero slope and power consumption is less as compared to that of hard clipping. After clipping

process, filtering method is applied which uses additional FFT and IFFT stages to remove the out of band noise.

A modified Iterative Amplitude clipping and filtering (IACF) technique has been proposed to reduce the PAPR in OFDM signal by Sharma *et al* [36]. The paper evaluates PAPR reduction effect with a band limiting filter in the iterative clipping and filtering method. PAPR and BER performance are improved compared to the conventional amplitude filtering method. OFDM signals are clipped in the digital part to reduce the peak factor. This method suffers from the problem of clipping distortion, peak re-growth and out of band radiation. Oversampling is used to control the effect of peak re-growth. If the bandwidth of the system can be increased, clipping distortion can be reduced.

Ragusa *et al* [37] has proposed a new method to avoid the large fluctuation of OFDM signals based on clipping and filtering. A technique called invertible clipping based on invertible clipping function is performed. Inter-modulation product noise is decreased and degradation is reduced at the cost of increased computational complexity.

Galda *et al* [38] has shown that PAPR of the uplink OFDM transmit signal can be greatly reduced if this OFDM-FDMA multiple access scheme is additionally combined with a data spreading technique based on a Discrete Fourier Transform spreading matrix. DFT and IDFT operation cancel out each other and PAPR is reduced to that of a single carrier system. As PAPR problem is more severe in uplink as the battery consumption in mobile degrades due to the problem of PAPR. So this method has been adopted for 3GPP LTE uplink.

Salah *et al* [39] proposed a method to reduce the PAPR in the uplink of 3GPP LTE uplink by using super frame SC-FDMA and intermediate frequency division mission. The number of subcarriers which are denoted by N and frames are denoted by B . B frames with N subcarriers will be combines into one super frame. This frame requires no side information.

Beraidinelli [40] has compared performances of OFDMA and SC-FDMA. OFDMA has the benefits of spectrum efficiency, mitigation of multipath propagation but has the drawback of

high PAPR, offset. The alternative of OFDMA is SC-FDMA with a comparatively low PAPR problem. The difficulty of SC-FDMA lies in its equalization.

Myung [41] has studied the performance of SC-FDMA for uplink wireless transmission. SC-FDMA has the advantage of lower PAPR than OFDMA and it has been adopted in the uplink of 3GPP LTE wireless system. Among the possible subcarrier techniques, localized FDMA with channel dependent scheduling results in higher throughput than interleaved FDMA but the performance of PAPR of IFDMA is better than LFDMA. Channel dependent scheduling tells us how we should allocate time and frequency resources fairly among users while achieving multi user diversity of frequency diversity.

Eshuaraih [42] has analyzed that in addition to use SC-FDMA in the uplink, it can also be used in the downlink for wireless system. The benefits of using SC-FDMA in the downlink include less BER and less PAPR. Joint equalization is used which can be carried out using low complexity equalization techniques. A local neighborhood search based equalization algorithm for SC-FDMA has been provided in this paper.

Rohling [43] has studied the combination of OFDM and CDMA. This combination is equivalent to a single carrier system with guard interval, if the columns of a fourier matrix are used as spreading codes. FFT matrix is basically used a spreading. FFT matrix is basically used as spreading matrix for OFDM-CDMA. The proposed scheme has the same performance as OFDM-CDMA but is less sensitive to non linear effects.

Cha [44] has developed a signal model for the transmission of discrete Fourier transform spread orthogonal division multiplexing in a frequency selective channel. This method uses sphere decoding algorithm to reduce the complexity of maximum likelihood estimation compared to the exhaustive ML search. This method provides significant improvement in BER. Sphere decoding algorithm reduces the complexity by constraining the search to within a specified radius.

Fang [45] has discussed the method of interleaved sub carrier allocation for DFT spread OFDM to reduce the PAPR. Interleaved allocation is a method of sub carrier mapping which employs an additional DFT stage in OFDM transmitter. This method features the lowest PAPR and gives better BER performance at high input power compared with original OFDM.

Cho [46] has studied the utilization of null subcarriers for PAPR reduction in 3GPP LTE downlink. Dummy sequence insertion (DSI) concept is an efficient PAPR reduction method because it is very simple to implement and side information is not needed. There is a decrease in transmitter data rate as DSI method requires a large number of dummy subcarriers to approach the desired PAPR reduction level..

Myung *et al* [47] has discussed the role played by sub carrier mapping in the transmitter of SC-FDMA. Let there be N point DFT taken ahead of M point IDFT, where $N < M$ and M is the total number of subcarriers. Basically sub carrier mapping can be achieved in 2 ways: localized and distributed sub carrier mapping. In localized sub carrier mapping, the unused number of subcarriers are set to zero whereas in distributed mode, the symbols are uniformly placed. Interleaving sub carrier mapping is a special case of distributed sub carrier mapping in which the sub carriers are equidistant from each other.

On the basis of above survey, a table has been made which is as follows:

Table 3.1: Comparison of PAPR reduction techniques [32]

Method	Distortionless	Power increase	Data rate loss
Clipping and filtering	No	No	No
Coding	Yes	No	Yes
PTS	Yes	No	Yes
SLM	Yes	No	Yes
Tone reservation	Yes	Yes	Yes
Tone injection	Yes	Yes	Yes
DFT spreading	Yes	No	No
Active Constellation	Yes	Yes	Yes

CHAPTER 4: MATHEMATICAL ANALYSIS

4.1 OFDM: Modulation and Demodulation

In OFDM, IDFT is used to generate the sub-carriers which are orthogonal to each other. First of signal is modulated using QPSK or QAM. Then the signal is passed through serial to parallel converter for generating parallel carriers and then sub carriers are modulated.

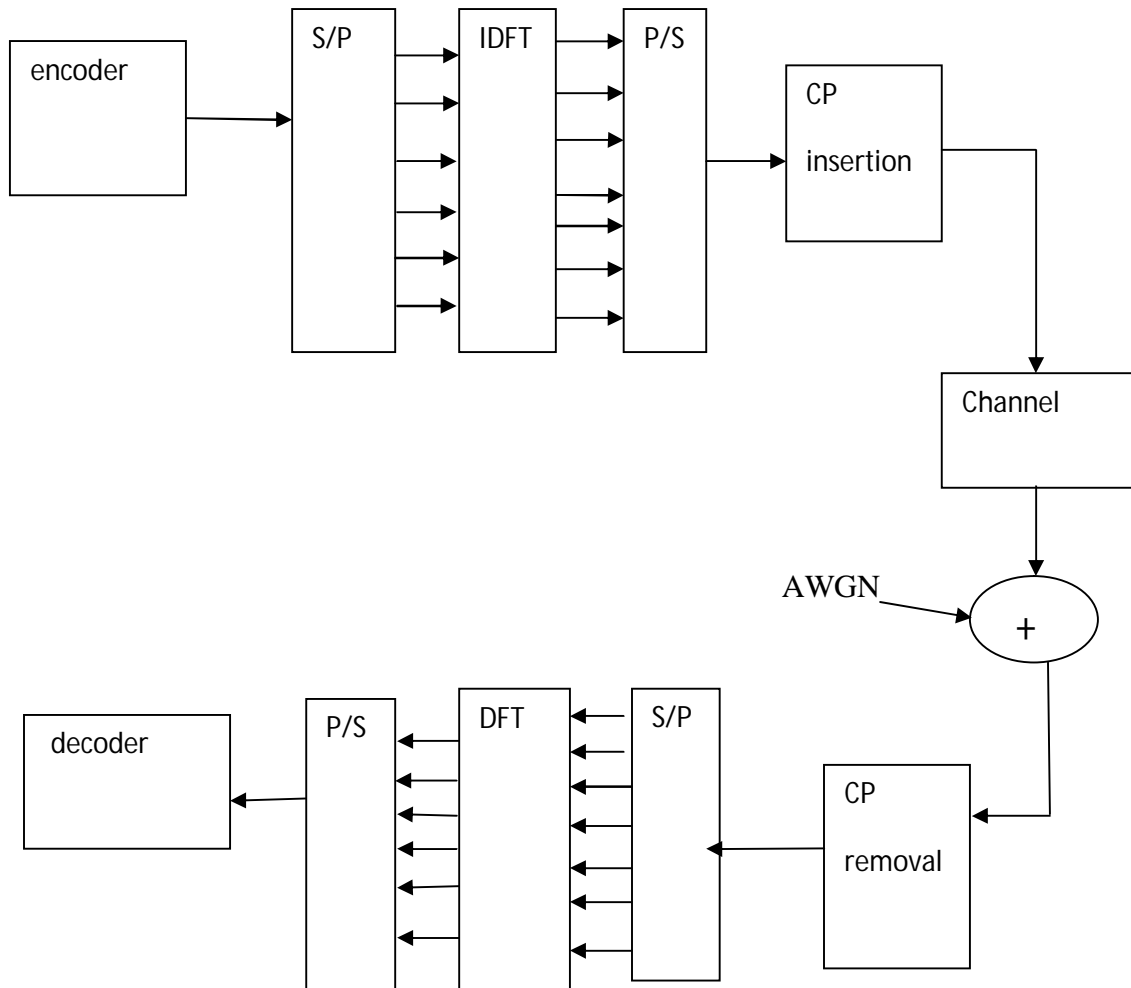

Figure 4.1: OFDM-Modulation and Demodulation

4.1.1 Orthogonality

Consider the time limited complex exponential signals $\int_{t=0}^{N-1} e^{j2\pi t f_k} dt$ which represent the different subcarriers at $f_k = k/T$ in the OFDM signal. These signals are defined to be orthogonal if the integral of the products of their common product is zero i.e. is

$$\int_0^T e^{j2\pi f_k t} e^{-j2\pi f_i t} dt = \int_0^T e^{j2\pi \left(\frac{k}{T}\right)t} e^{-j2\pi \left(\frac{i}{T}\right)t} dt \quad (4.1.1.1)$$

$$= \int_0^T e^{j2\pi \left(k - \frac{i}{T}\right)t} dt \quad (4.1.1.2)$$

$$= \begin{cases} 1, & \text{if } k = i \\ 0, & \text{otherwise} \end{cases} \quad (4.1.1.3)$$

So, the above equation shows that after the operation of IDFT, the subcarriers produced are orthogonal in nature.

OFDM transmitter maps the message bits into a sequence of PSK or QAM symbols which will be subsequently converted into N parallel streams. Let $C_{l,k}(t)$ denote the l th OFDM signal at the k th subcarrier, which is given as:

$$C_{l,k} = \begin{cases} e^{j2\pi f_k(t-lT)}, & 0 < t < T \\ 0, & \text{otherwise} \end{cases} \quad (4.1.1.4)$$

Then the passband and baseband OFDM signals in the time domain can be expressed as:

$$x_l(t) = \text{Re} \left\{ \frac{1}{T} \sum_{k=0}^{N-1} X_l[k] C_{l,k}(t) \right\} \quad (4.1.1.5)$$

$$x_l(t) = \sum_{k=0}^{N-1} X_l[k] e^{j2\pi f_k(t-lT)}$$

(4.1.1.6)

Therefore, the corresponding discrete time OFDM symbol is:

$$x_l(n) = \sum_{k=0}^{N-1} X_l[k] e^{j\frac{2\pi kn}{N}}$$

(4.1.1.7)

Now consider the received baseband OFDM symbol

$$y_l(n) = \sum_{k=0}^{N-1} X_l[k] e^{j2\pi f_k(t-lT)}$$

(4.1.1.8)

From which the transmitted symbol can be reconstructed by the orthogonality among the subcarriers as follows:

$$Y_l(k) = \frac{1}{T} \int_{-\infty}^{\infty} y_l(t) e^{j2\pi f_k(t-lT)} dt$$

(4.1.1.9)

$$= \frac{1}{T} \int_{-\infty}^{\infty} \sum_{k=0}^{N-1} X_l[k] e^{j2\pi f_k(t-lT)} e^{j2\pi f_k(t-lT)} dt$$

(4.1.1.10)

$$= X_l(k)$$

(4.1.1.11)

4.1.2 Cyclic prefix

In cyclic prefix, the last part of symbol is copied to the front part to make it circularly convolve.

$$y_l[n] = x_l[n - m] * h_l[n] + z_l[n]$$

(4.1.2.1)

$$Y_l(k) = \sum_{n=0}^{N-1} y_l[n] e^{-\left(\frac{j2\pi kn}{N}\right)} \quad (4.1.2.2)$$

$$= \sum_{n=0}^{N-1} x_l[n-m] * h_l[n] + z_l[n] e^{-j2\pi kn/N} \quad (4.1.2.3)$$

By solving, we get

$$= H_l[k]X_l[k] + Z_l[k] \quad (4.1.2.4)$$

4.2 Mathematical Analysis of PAPR

PAPR stands for peak to power average ratio and is given as:

$$\text{PAPR} = \left\{ \frac{P_{\text{peak}}}{P_{\text{avg}}} \right\} = \frac{\max[x(t)]^2}{E[x(t)]^2} \quad (4.2.1)$$

where, E[.] = expectation of signal

x(t) = signal to be transmitted

PAPR can be further divided into Baseband PAPR and Passband PAPR:

1 Baseband PAPR: It is further divided into continuous time PAPR and discrete time PAPR.

a) Continuous time PAPR: It is defined as the ratio between the maximum instantaneous power and its average power.

$$\text{PAPR}[x(t)] = \frac{\max[|x(t)|^2]}{P_{av}} \quad \text{for } 0 < t < NT \quad (4.2.2)$$

Where P_{av} is the average power of x(t) which can be computed in the frequency domain.

b) Discrete time PAPR: The PAPR of the discrete time sequences squares up the complexity of the digital circuitry in terms of the number of bits necessary to achieve a desired SQNR

for both the digital operation and DAC. To better approximate the PAPR of OFDM signals, the OFDM signals samples are obtained by L times oversampling. L times oversampled time domain samples are LN point IFFT of the data block with (L-1)N zero padding. The PAPR calculated from L times oversampled discrete time domain.

$$\text{PAPR}[x(n)] = \frac{\max[|x(n)|^2]}{E[|x(n)|^2]} \quad \text{for } 0 < n < NL - 1 \quad (4.2.3)$$

where, E[.] denotes the expected value.

2. Passband PAPR: The power spectral density of the band limited OFDM signal is rectangular. But if number of subcarriers is more, then an OFDM system does not employ pulse shaping. The amplitude of OFDM signals can be expressed as:

$$x_{PB} = \text{Re}\{x(t)e^{j2\pi f_c t}\} \quad (4.2.4)$$

Where f_c is the carrier frequency and $f_c \gg \Delta f$. Therefore, the peak of RF signals is equivalent to that of the complex baseband signals. The average power of the passband signals is:

$$E[|x_{PB}(t)|] = E[|\text{Re}\{x(t)e^{j2\pi f_c t}\}|^2] \quad (4.2.5)$$

$$= E[|\{x_I(t)\cos(2\pi f_c t) - x_Q(t)\sin(2\pi f_c t)\}|^2] \quad (4.2.6)$$

$$= \frac{1}{2} E[|s(t)|^2] \quad (4.2.7)$$

Therefore, the passband PAPR is approximately twice the baseband PAPR, i.e.

$$\text{PAPR}\{x_{PB}(t)\} = 2\text{PAPR}\{x(t)\} \quad (4.2.8)$$

CCDF: Complimentary cumulative distribution function is the perimeter used to calculate the PAPR. It describes the probability that a real-valued random variable X with a given probability distribution will be found at a value less than or equal to x. In the case of a continuous distribution, it gives the area under the probability density function from minus infinity to x. Cumulative distribution functions are also used to specify the distribution of

multivariate random variables. The CCDF curve also shows the amount of time a signal spends above the average power level of the measured signal, or equivalently, the probability that the signal power will be above the average power level.

The CDF of the amplitude of a signal sample is given by:

$$F(z) = 1 - e^{-z} \quad (4.2.9)$$

The CCDF of the PAPR of the data block is desired in our case to compare outputs of various reduction techniques. This is given as

$$\text{Prob}\{\text{PAPR} > z\} = 1 - (1 - e^{-z})^N \quad (4.2.10)$$

Where N is the number of subcarriers used.

However above equation do not hold when the value of N is large. For an OFDM system with very large value of N, we use the following equation:

$$\text{Prob}\{\text{PAPR} > z\} = 1 - (1 - e^{-z})^{2.8N} \quad (4.2.11)$$

When the constraint provides a lower bound, the effect on the accuracy of the PAPR distribution can be numerically evaluated as:

$$\text{Prob}\{\text{PAPR} > z\} = 1 - \exp\left\{-Ne^{-z} \sqrt{\frac{\pi z}{3}}\right\} \quad (4.2.12)$$

A simple expression of the CCDF of PAPR has been developed by employing the extreme value theory and can be written as:

$$\text{Prob}\{\text{PAPR} > z\} = 1 - \exp\left\{-Ne^{-z} \sqrt{\frac{\pi \log N}{3}}\right\} \quad (4.2.13)$$

4.3 Mathematical Analysis of DFT spreading

As we know that in DFT spreading subcarrier mapping can be done in 2 ways. One is by using distributed FDMA and the other is by using localized FDMA.

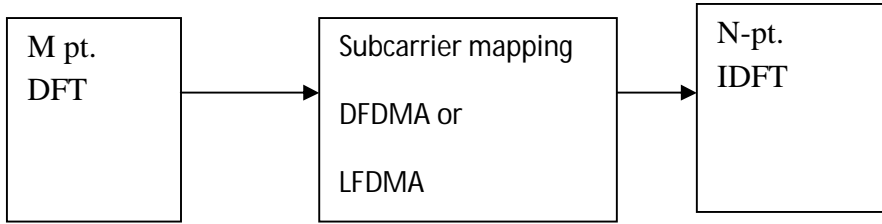

Figure 4.2: Subcarrier mapping

4.3.1 Distributed FDMA

It distributes M DFT outputs to M consecutive subcarriers in N subcarriers and the rest are padded with zeros. Thus in distributed system, the information is spread across the entire system bandwidth. It offers additional diversity gain. It is also more robust with respect to frequency selective fading.

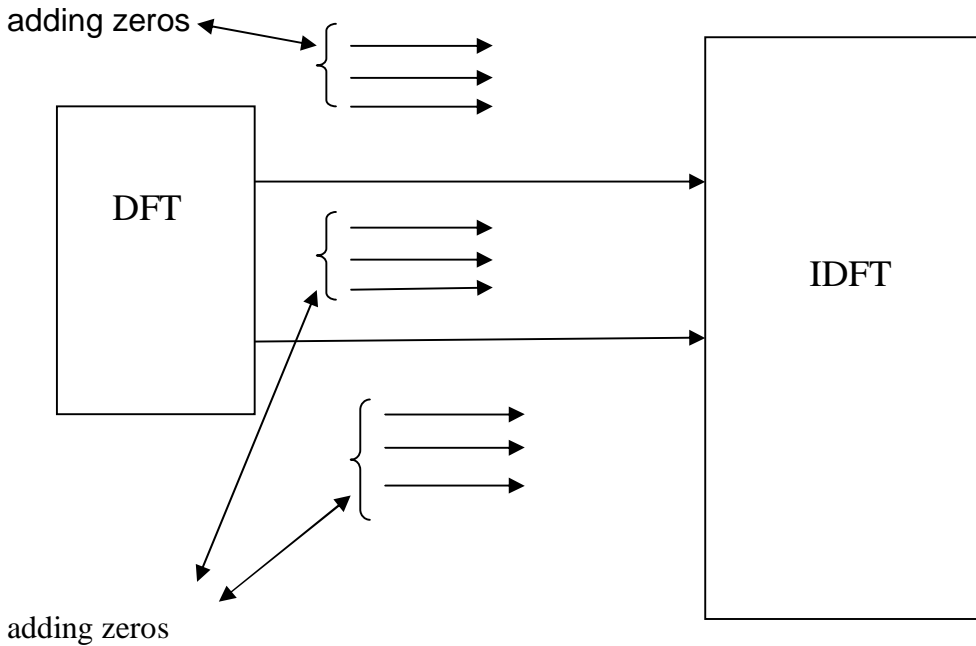

Figure 4.3: Distributed FDMA

4.3.2 Localized FDMA

In this method, all of the data is taken collectively and the rest unused subcarriers are filled with zeros. Localized FDMA in combination with channel dependent scheduling can provide multi user diversity in frequency selective channel conditions.

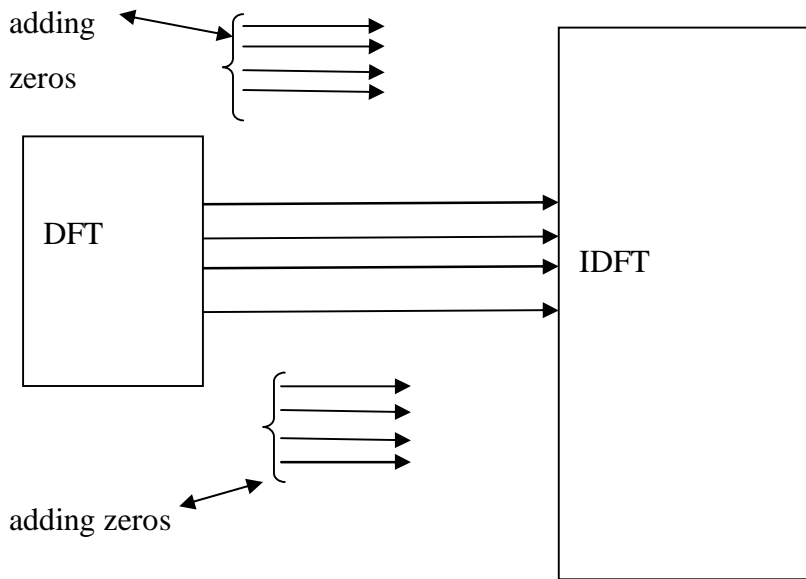

Figure 4.4: Localized FDMA

4.3.3 Derivation: IFDMA

IFDMA is a special form of DFDMA used for subcarrier mapping from DFT to IDFT.

Let u_r ($r=0; 1, \dots, K-1$) represents the input symbols, U_k ($k=0; 1, \dots, K-1$) represents the outputs of the DFT operation, and v_l represents the output of the IDFT operation.

The subcarrier mapping process for IFDMA can be expressed as:

$$Y_q = \begin{cases} U_k, & q = kj + i \\ 0, & otherwise \end{cases} \quad (4.3.3.1)$$

where $i = 0; 1, \dots, J-1$ is the user index. Let $l = Kp + r$, for $0 \leq r \leq K-1$ and $0 \leq p \leq J-1$.

$$v_l = v_{Kp+r} \tag{4.3.3.2}$$

$$= \frac{1}{N} \sum_{q=0}^{N-1} U_k e^{\frac{j2\pi l q}{N}} \tag{4.3.3.3}$$

$$= \frac{1}{N} \sum_{k=0}^{K-1} U_k e^{\frac{j2\pi l k}{N}} \tag{4.3.3.4}$$

$$= \frac{1}{KJ} \sum_{k=0}^{K-1} U_k e^{\frac{j2\pi l k Q}{KJ}} \tag{4.3.3.5}$$

$$= \left(\frac{1}{J}\right) \left\{ \frac{1}{N} \sum_{q=0}^{N-1} U_k e^{j2\pi K \left(\frac{kp+r}{K}\right) q} \right\} \tag{4.3.3.6} \text{ by (4.3.3.2)}$$

$$= \left(\frac{1}{J}\right) \left\{ \frac{1}{N} \sum_{q=0}^{N-1} U_k e^{j2\pi kr q/K} e^{j2\pi p k q} \right\} \tag{4.3.3.7}$$

$$= \frac{1}{J} u_r \tag{4.3.3.8}$$

4.3.4 Derivation: LFDMA

Let u_r ($r = 0; 1, \dots, K-1$) represents the input symbols, U_k ($k = 0; 1, \dots, K-1$) represents the outputs of the DFT operation, and v_l represents the output of the IDFT operation

The subcarrier mapping process for LFDMA can be expressed as:

$$Y_q = \begin{cases} U_k, & 0 < k < K-1 \\ 0, & K < k < N-1 \end{cases} \tag{4.3.4.1}$$

Let, $l = Jr + p$, where $0 < r < K-1$ and $0 < p < J-1$. Then

$$v_l = v_{Jr+p} \quad (4.3.4.2)$$

$$= \frac{1}{N} \sum_{q=0}^{N-1} U_k e^{\frac{j2\pi lq}{N}} \quad (4.3.4.3)$$

$$= \frac{1}{N} \sum_{k=0}^{K-1} U_k e^{\frac{j2\pi lk}{N}} \quad (4.3.4.4)$$

$$= \frac{1}{N} \sum_{k=0}^{K-1} U_k e^{\frac{j2\pi(Jr+p)k}{JK}} \quad (4.3.4.5) \text{ by (4.3.4.2)}$$

If $p=0$, then

$$v_l = v_{Jr} \quad (4.3.4.6)$$

$$= \frac{1}{KJ} \sum_{k=0}^{K-1} U_k e^{\frac{j2\pi rk}{K}} \quad (4.3.4.7)$$

$$= \left(\frac{1}{J}\right) \left\{ \frac{1}{K} \sum_{k=0}^{K-1} U_k e^{\frac{j2\pi rk}{K}} \right\} \quad (4.3.4.8)$$

$$= \frac{1}{J} u_r \quad (4.3.4.9)$$

CHAPTER 5: RESULTS AND DISCUSSIONS

In this chapter, different PAPR reduction techniques have been simulated and comparison has been made between results of these techniques. For this simulation, we have used MATLAB R2011a (version7.12).

1. CCDF Vs PAPR: Plotting CCDF Vs PAPR for OFDM for different number of subcarriers. As we increase the number of subcarriers from 128 to 1024, the PAPR of OFDM increases due to the fact that PAPR is directly proportional to number of subcarriers used.

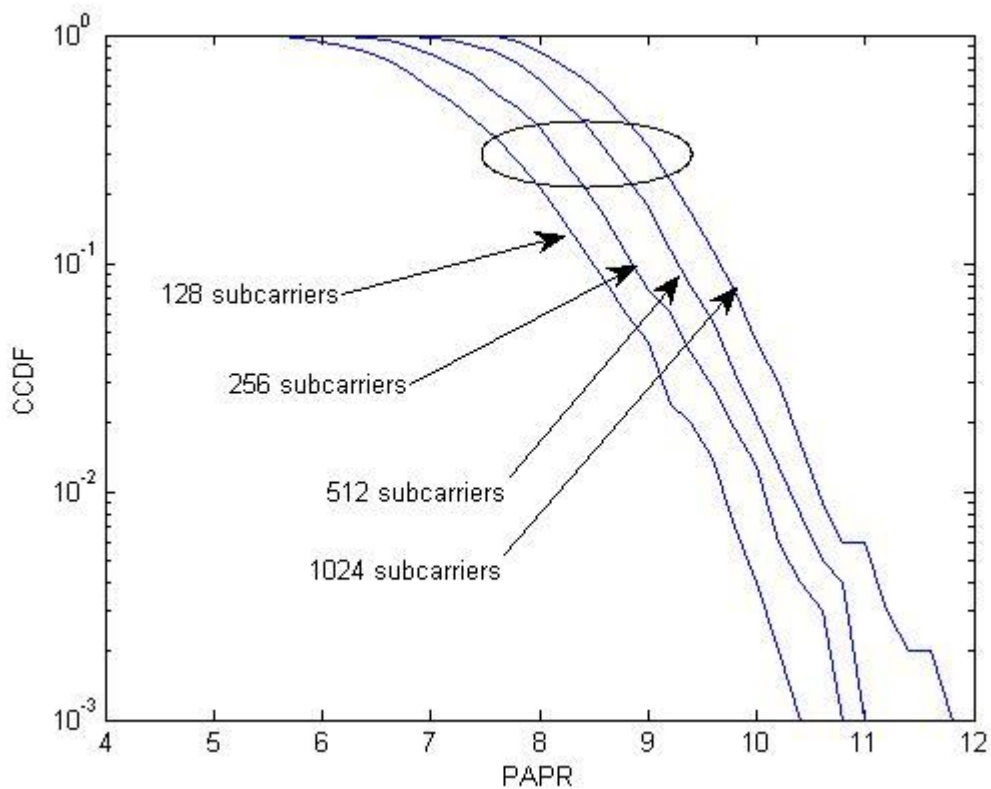

Figure 5.1: CCDF Vs PAPR for different subcarriers

2. CCDF Vs PAPR for LFDMA: Plotting CCDF Vs PAPR for different adaptive modulation techniques. Here PAPR of Localized FDMA has been calculated. LFDMA is a part of SCFDMA. In this we have taken 128 point IFFT and we have spread it with 64 point FFT and the rest subcarriers have been taken as null. We have made the system look like single carrier system. It is also called DFT spreading. We have calculated it for both QPSK and 6 QAM.

Number of IFFT blocks	128
Number of FFT blocks	64
Modulation	QPSK,16 QAM
Iterations	1000
Spreading Factor	2

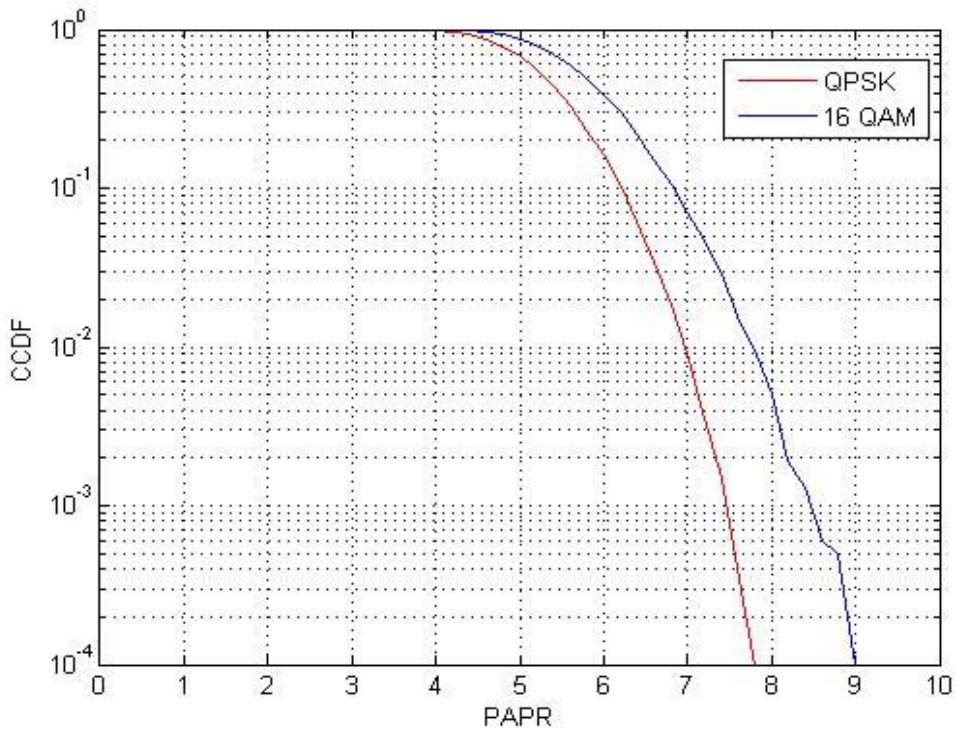

Figure 5.2: CCDF Vs PAPR for LTE uplink

3. CCDF Vs PAPR: Plotting CCDF Vs PAPR for both LTE uplink and downlink (LFDMA and OFDMA respectively) for QPSK. Here we have compared PAPR for both OFDMA and LFDMA. After performing simulation, it is clear that PAPR of SCFDMA is quite less as compare to OFDMA. The modulation technique used in this simulation is QPSK.

Modulation	QPSK
FFT size	64 point
IFFT size	128 point
Type	Localized FDMA
No. of iterations	10000

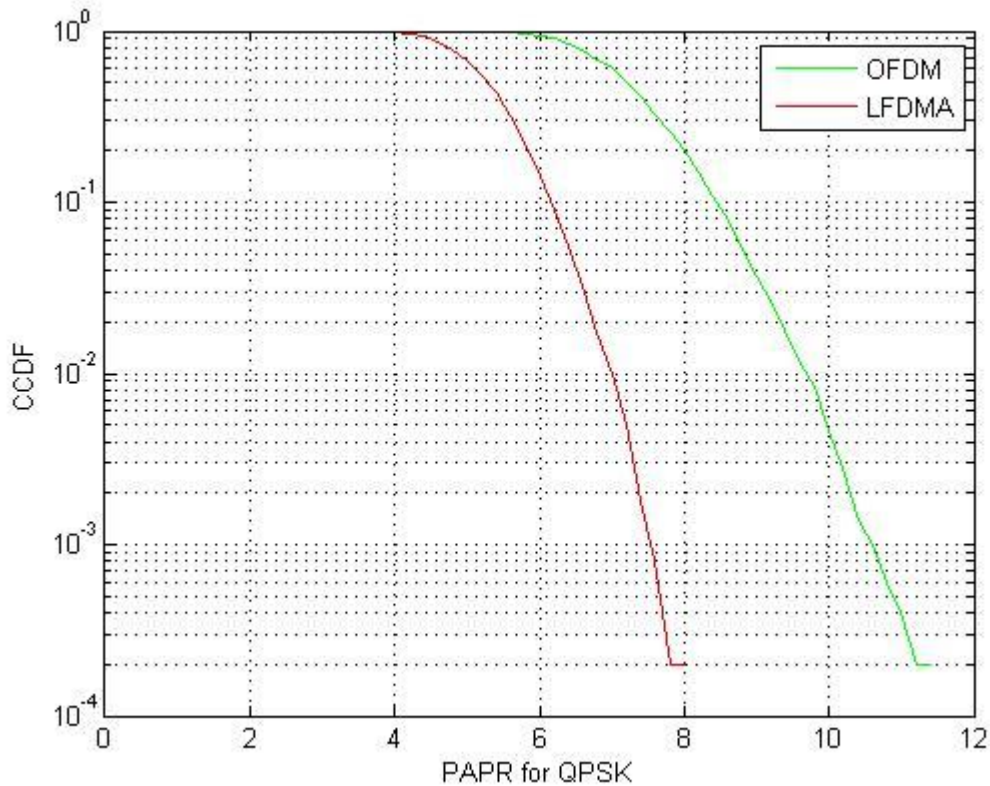

Figure 5.3: PAPR Vs CCDF for LFDMA and OFDMA for QPSK

4. CCDF Vs PAPR: Plotting CCDF Vs PAPR for OFDMA and LFDMA for 64 QAM. This is the same simulation as above. The difference is in adaptive modulation technique. Here we have done simulation for 64 QAM and the result shows that as we move from QPSK to 64 QAM, PAPR increases.

IFFT	128
FFT	64
Mod.	64-QAM
Blocks	1000

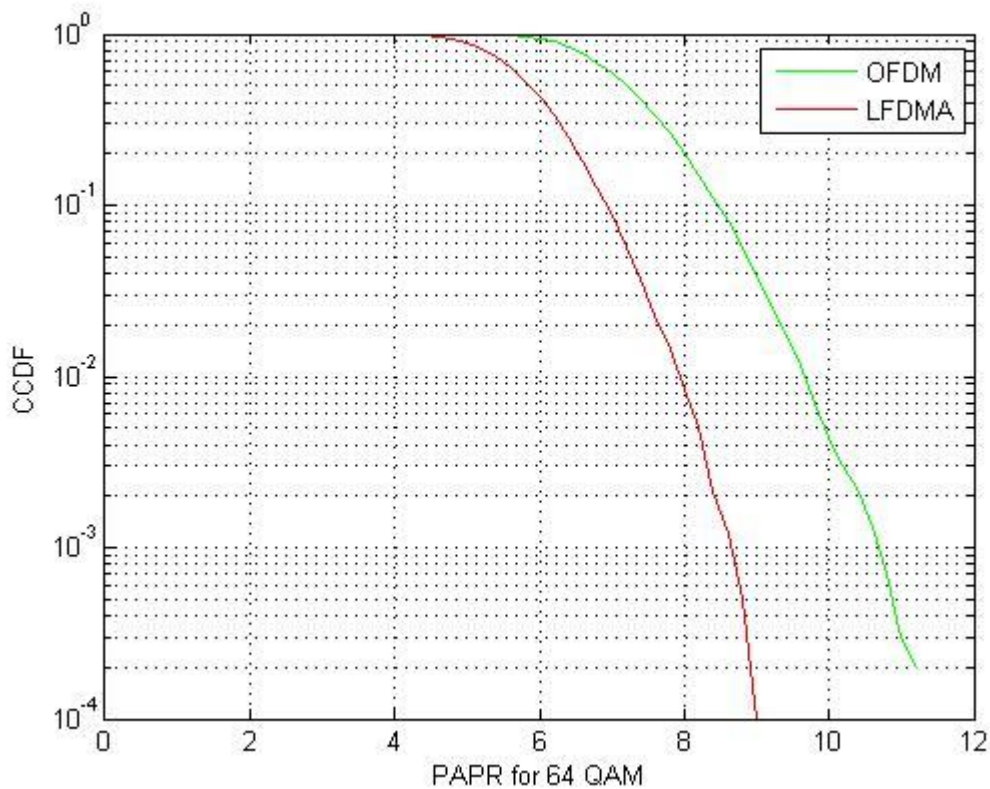

Figure 5.4: CCDF Vs PAPR for LFDMA and OFDMA for 64 QAM

5. CCDF Vs PAPR: Plotting CCDF Vs PAPR for OFDMA and IFDMA for 16 QAM. Here we have calculated PAPR for IFDMA and compared it with OFDMA. Interleaved FDMA is a type of SCFDMA in which subcarriers are placed in such a way that they are equidistant from each other. This method produces the lowest PAPR.

Modulation	16-QAM
FFT size	64 point
IFFT size	128 point
Spreading factor	2
FDMA type	Interleaved
No. of ofdm blocks	10000

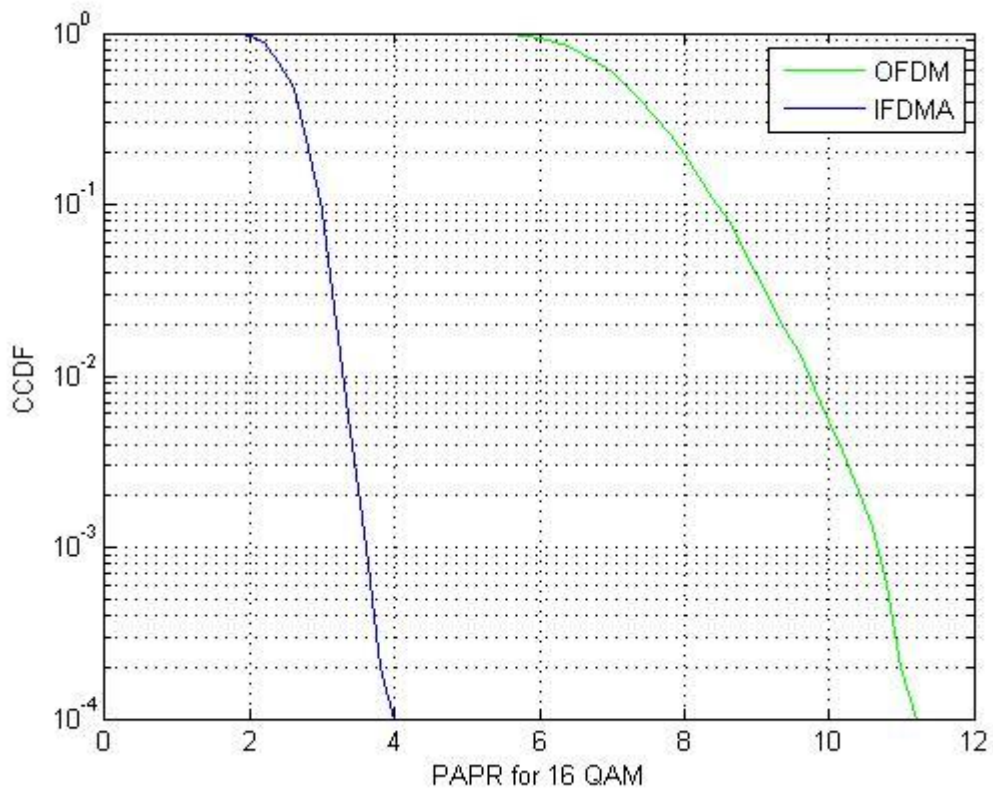

Figure 5.5: PAPR Vs CCDF for IFDMA and OFDMA for 16 QAM

6. CCDF VS PAPR: Plotting CCDF Vs PAPR for IFDMA and OFDMA for 64 QAM. Here we have calculated PAPR for IFDMA and OFDMA for 64 QAM.

IFFT Size	128
FFT Size	64
Spreading Factor	2
Iterations	5000
Type	Interleaved

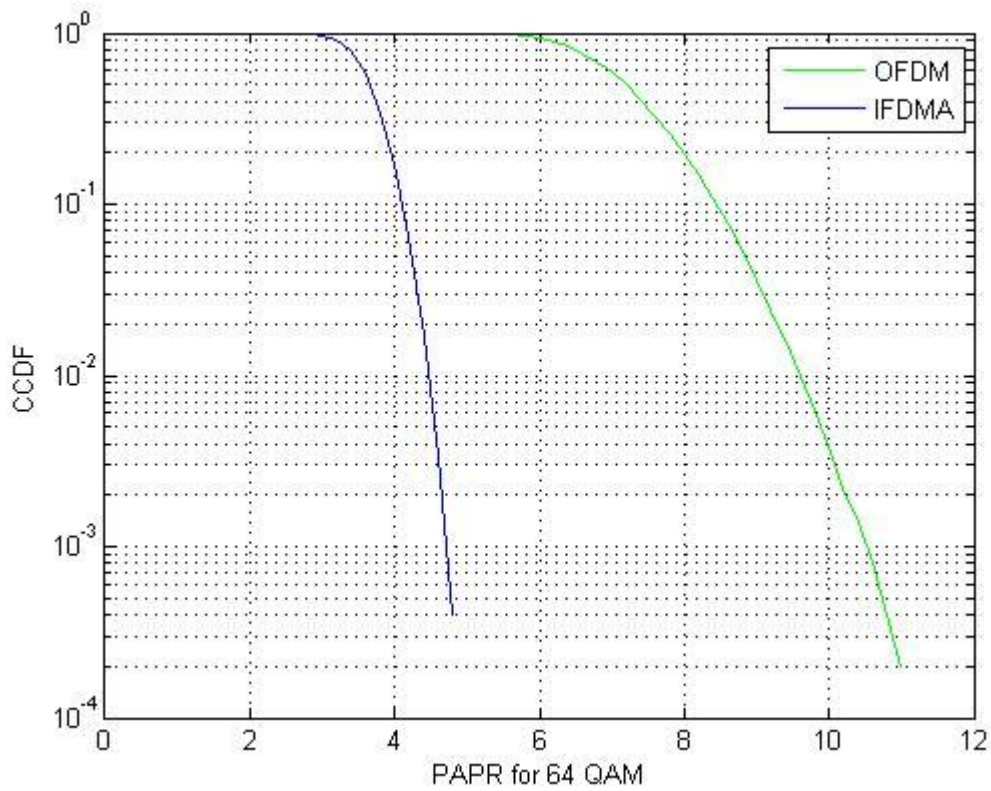

Figure 5.6: PAPR Vs CCDF for OFDMA and IFDMA for 64QAM

7. CCDF Vs PAPR: In this simulation, we have made a comparison on all the 3 methods i.e. LFDMA, IFDMA and OFDMA for QPSK.

IFFT Size	128
FFT size	64
Modulation	QPSK
Spreading factor	2

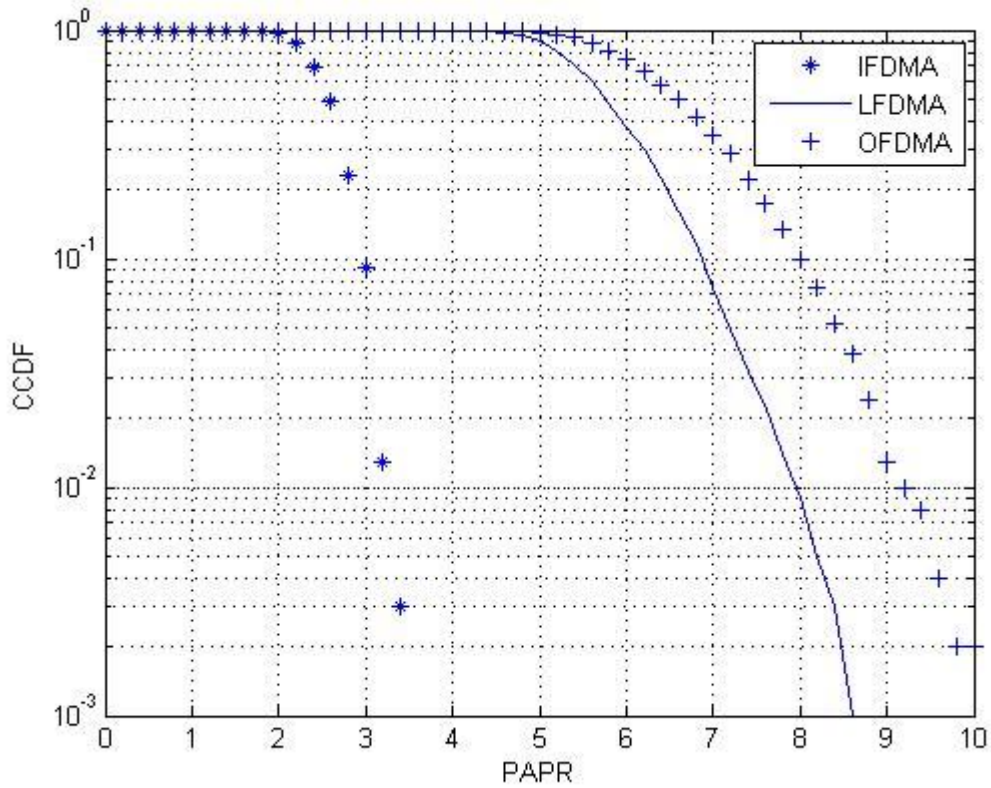

Figure 5.7: CCDF Vs PAPR for IFDMA, LFDMA and OFDMA

CHAPTER 6: CONCLUSIONS and FUTURE WORK

From the different simulations done, we have been able to compare the PAPR of both the uplink and downlink of 3GPP LTE. LTE uses SCFDMA in uplink and OFDMA in downlink. SCFDMA method is of 3 types: LFDMA, DFDMA and IFDMA. From above simulations, we have drawn conclusion in the tabular form:

Table 6.1: PAPR for QPSK at CCDF = 10^{-1}

Method	PAPR(in dBs)
LFDMA	6.8
IFDMA	3
OFDMA	8

Table 6.2: PAPR for 16 QAM at CCDF = 10^{-1}

Method	PAPR(in dBs)
LFDMA	7.2
IFDMA	3.5
OFDMA	8.5

Table 6.3: PAPR for 64 QAM at CCDF = 10^{-1}

Method	PAPR(in dBs)
LFDMA	7.3
IFDMA	4.2
OFDMA	8.6

From above, we have included with increase in adaptive modulation techniques from QPSK to 16 QAM PAPR increases and PAPR of IFDMA (interleaved FDMA) which is type of SCFDMA is lowest, that's why SCFDMA has been adopted in uplink of 3GPP LTE where power consumption is an important issue. Furthermore, if we apply pulse shaping to IFDMA, its PAPR increases and that of LFDMA remains constant.

From the literature survey, it is clear that clipping introduces in band distortion, coding method does not reduce PAPR to a greater extent, PTS increases complexity of the system.

Due to low PAPR content, SCFDMA which is pre-coded version of OFDMA has been adopted in 3GPP LTE uplink as battery power consumption is more critical. In the future, we would like to work on SCFDMA in downlink as well. By combining SCFDMA with MU-MIMO (multi user multiple input and output), we get better diversity due to properties of SCFDMA as compared to MU-MIMO OFDMA. Currently research is going to make SCFDMA applicable in both uplink and downlink

REFERENCES:

- [1] U.Reimers, "Digital Video Broadcasting," *IEEE Commun. Mag.*, vol. 36, no. 10, June 1998, pp. 104–10.
- [2] T.S. Rappaport and others,"Wireless Communication:principles and practice",Prentice Hall PTR New Jersey,1996.
- [3] S.Haykin,"Communication System,"John Wiley & sons,New Jersey,2001.
- [4] V.Vij,"Wireless Communication,Laxmi", Publication,Ltd.,2010.
- [5] Suhas Mathur,"Small Scale fading in Radio propagation",department of electrical engineering,Rugters University,Lecture Notes for Wireless Communication Technologies.
- [6] source www.3gpp.org
- [7] source <http://en.wikipedia.org/wiki/3GPP>
- [8] Astley,D.;Dahlman,H;Frushar,K;Jading,"LTE-the evolution of Mobile Broadband",*IEEE Communication* vol.47,issue 4,april 2009.
- [9] H.Holma and Toshala,"LTE for UMTS:OFDMA and SCFDMA based radio access",John Wiley and Sons Inc.,2009.
- [10] S.Sesia,I.Toufik and M.Becher,"LTE-the UMTS long term evolution:from theory to practice",John Wiley and Sons,2009.
- [11] Hyung G.Myung,"Technical Overview of 3GPP LTE",2008.
- [12] "LTE for 4G Mobile Broadband Air...."-Google Books.
- [13] Jim Zyren,"Overview of the 3GPP long term evolution physical layer"2007,White Paper.
- [14] "3GPP LTE Channels and MAC layer"event helix.com Inc.,2009,White Paper.
- [15] R.W. Chang. "Synthesis of band-limited orthogonal signals for multichannel data transmission," *Bell Systems Tech. Journal*, vol. 45, pp.1775–1796, Dec. 1966.
- [16] "Orthogonal Frequency Division Multiplexing." U.S. Patent No. 3, 488, 4555, filed November 14, 1966, issued Jan. 6, 1970
- [17] Weinstein and P. Ebert, "Data transmission by frequency-division multiplexing using the discrete Fourier transform," *IEEE Trans. Communication. Technol.*, vol. 19, no. 5, pp. 628–634, Oct. 1971

- [18] Peled and A. Ruiz, "Frequency domain data transmission using reduced computational complexity algorithms," *In Proc. IEEE International Conference on Acoustics, Speech, and Signal Processing*, volume 5, pp. 964-967, April 1980.
- [19] MIMO OFDM wireless communication with MATLAB by Yong Soo Cho., Jaekwon Kim, Won Young Yang (Wiley Publishers).
- [20] H. G. Myung, J. Lim, and D. J. Goodman, "Single carrier FDMA for uplink wireless transmission," *IEEE Veh. Technol. Mag.*, vol. 1, no. 3, pp. 30–38, Sep. 2006.
- [21] Hughes Systique, "Uplink Physical Channels", Available; <http://wiki.hsc.com/> online: http://wiki.hsc.com/LTE_PHY#UplinkPhysicalChannels.
- [22] P.Siva Kumar, S.Sangeetha, Dr.M.Rajaram, "PAPR reduction in OFDM for SCFDMA channels", *IJSCCN* 2011.
- [23] U. Sorger, I. De Broeck, and M. Schnell, "Interleaved FDMA—A new spreading spectrum multiple access scheme," *in Proc. IEEE Int. Conf. Commun.*, Jun. 1998, pp. 1013–1017.
- [24] G. L. Ren, H. Zhang, and Y. L. Chang, "A complementary clipping transform technique for the reduction of peak-to-average power ratio of OFDM system," *IEEE Trans. Consumer Electronics*, vol. 49, no. 4, pp. 922–926, Nov. 2003.
- [25] Tao Jiang, Yang Yang, Yong-hua Song, "Exponential Companding technique for PAPR reduction in OFDM system" *IEEE Broadcasting Transaction*, Vol:51, Issue:2, June 2005, Pg.244-248.
- [26] E. Jones, T. A. Wilkinson, and S. K. Barton, "Block coding scheme for reduction of peak-to-average envelope power ratio of multicarrier transmission systems," *IEEE Electronics Letters*, vol. 30, no. 8, pp.2098–2099, Dec. 1994.
- [27] S. J. Heo, H. S. Noh, J. S. No, and D. J. Shin, "A modified SLM scheme with low complexity for PAPR reduction of OFDM systems," *IEEE Trans. Broadcasting*, vol. 53, no. 4, pp. 804–808, Dec. 2007.
- [28] L. Wang and Q. Y. Yuan, "Low-complexity selected mapping schemes for peak-to-average power ratio reduction in OFDM systems," *IEEE Trans. Signal Processing*, vol. 53, no. 12, pp. 4652–4660, Dec. 2005

- [29] L. Yang, R. S. Chen, Y. M. Siu, and K. K. Soo, "PAPR reduction of an OFDM signal by use of PTS with low computational complexity," *IEEE Trans. Broadcasting*, vol. 52, no. 1, pp. 83–86, Mar. 2006.
- [30] S. H. Han, J. H. Lee, "PAPR Reduction of OFDM Signals Using a Reduced Complexity PTS Technique", *IEEE Signal Processing Letters*, vol. 11, no. 11, November 2004
- [31] J. C. Chen and C. P. Li, "Tone reservation using near-optimal peak reduction tone set selection algorithm for PAPR reduction in OFDM systems," *IEEE Commun. Letter.*, vol. 17, no. 11, pp. 933–936, Nov. 2010
- [32] S. H. Han, J. H. Lee, "An Overview of Peak – to – Average Power Ratio Reduction Techniques for Multicarrier Transmission", *IEEE Transaction on Wireless Communication*, April 2005.
- [33] J. Armstrong, "PAPR reduction by repeated clipping and frequency domain filtering", *Electronics Letters*, Vol:38, Issue 5, 2002, pg.246-247.
- [34] Ajit Jha, Md. Sohel Mohmud Sher, S.M. Shamshul Alam, Md. Tariq Hasan and Md. Mizanur Rahman, "Reduction of Peak to Average Power Ratio (PAPR) in Orthogonal Frequency Division Multiplexing (OFDM): A Novel Approach Based on Clipping and Amplification." *2009 Fourth International Conference on Computer Sciences and Convergence Information Technology*.
- [35] Salvatore Ragusa, Jacques Palicot and Christian Lereau, "OFDM power ratio reduction using invertible clipping," *The 117th Annual IEEE International Symposium on Personal, Indoor and Mobile Radio Communications (PIMRC'06)*.
- [36] Chhavi Sharma, Pankaj kumar sharma, S.K. Tomar, A.K. Gupta, "A Modified Iterative Amplitude Clipping and Filtering Technique for PAPR Reduction in OFDM Systems," *IEEE Transaction on wireless communication*, vol.2, no.11, 2011.
- [37] Salvatore Ragusa, Jacques Palicat and Christian Lereau, "OFDM Power Ratio Reduction Using Invertible Clipping", *17th annual IEE international Symposium on Personal, Indoor and Mobile Radio Communication (PIMRC 06)*.
- [38] Galda, D. and Rohling, H. (2002) A low complexity transmitter structure for OFDM-FDMA uplink systems. *IEEE VTC'02*, vol. 4, pp. 1737–1741.

- [39] Mohamed Salah,Gamel Abdel Fadedand,Zahi B.Nosaaie,"Peak to average power reduction in single carrier OFDM system",*13th International Conference on Aerospace Sciences and Aviation Technology*,May 26-28,2009
- [40] Gilberto Beardinelli,Luis Angel Maestro,Simone Featassi,Muhammad Imadur Rahnam and Preben Mogensen,"OFDMA Vs SCFDMA-Performance Comparison in Local Area IMT Scenario",*IEEE Wireless Communication*,October 2008.
- [41] Myung, H.G. Lim, and Goodman, D.J. (2006) "Single carrier FDMA for uplink wireless transmission". *IEEE Veh. Technol. Mag.*, 1(3), 30–38.
- [42] Haesha S.Eshwaraih and A Chochalingam,"SCFDMA for Multiuser Communication on the Downlink".*IEEE transaction on the Downlink*",IEEE Transaction,2013.
- [43] R.Grunheid,H.Rohling,"Performance Comparison of different multiple access schemes for the downlink of an OFDM System",*In Proc. IEEE VTC*,1997
- [44] Pochun Yen Hlaing Minn and Chia-Chin Chong,"PAPR reduction for bandwidth aggregated OFDM and SCFDMA system",*IEEE WCNC 2011-PHY*.
- [45] Yuan Fang,Li jao and Nan Chi,"Interleaved Subcarrier allocation DFT-spread OFDM to reduce PAPR",*IEEE Transaction on Wireless Communication*, Vol.11,No.11,November 2012.
- [46] Soobum Cho,Sang Kiyu Park,Du-Jim Kwon,Dong Geol Ry,"Utilization for Null Subcarriers for PAPR in 3GPP LTE Downlink",*Proceedings of IC-NIDC 2012*.
- [47] Hyung G.Myung,David J.Goodman,"Single Carrier FDMA for uplink wireless transmission"*IEEE Vehicular technology magazine*,sept.2013

