

# PAPR AND SPECTRUM ANALYSIS OF 4G & 5G TECHNIQUES

*A Thesis Submitted in Fulfillment of the Requirement for the Award of the Degree of*

MASTER OF ENGINEERING

In

Electronics and Communication

Submitted By

**Roopdeep Kaur**

801661020

Under Supervision of

**Dr. Ashutosh Kumar Singh**

**Assistant Professor**



**THAPAR INSTITUTE**  
OF ENGINEERING & TECHNOLOGY  
(Deemed to be University)

ELECTRONICS AND COMMUNICATION ENGINEERING DEPARTMENT

THAPAR INSTITUTE OF ENGINEERING & TECHNOLOGY

(A DEEMED TO BE UNIVERSITY), PATIALA, PUNJAB

JULY, 2018

## DECLARATION

I, Roopdeep Kaur hereby declare that the work presented in this thesis entitled "PAPR and spectrum analysis of 4G and 5G techniques" in partial fulfillment of the requirement for the award of degree of Master of Engineering submitted at Electronics and Communication Engineering Department, Thapar University, Patiala is an authentic record of work carried out under supervision of Dr. Ashutosh Kumar Singh (Assistant Professor, ECED, Thapar University, Patiala). The matter presented in this has not been submitted either in part or full to any other university or institute for the award of any other degree.

Date: 09-07-2018

*Roopdeep Kaur*  
Roopdeep Kaur

801661020

It is certified that the above statement made by the candidate is correct to the best of my knowledge and belief.

Date: 09-07-2018

*Singh*  
Dr. Ashutosh Kumar Singh  
Assistant Professor TU  
ECED, Patiala

## **ACKNOWLEDGEMENT**

I would like to express my sincere gratitude to my research advisor **Dr. Ashutosh Kumar Singh, Assistant Professor** for his support and guidance during my course work. I have been inspired by his meticulousness, his attention to detail and his energetic application to any problem.

I value his concern and support at all times, good and bad. He has always emphasis on self-motivation during rough or bad periods and appreciated in good days. The words are not enough to thank him.

I am also thankful to Thapar University for the facilities and healthy environment for study. I also express my sincere thanks to my Head of the Department, **Dr. Alpana Aggarwal** for providing me adequate environment in carrying the work.

I am also thankful to **Dr. Hem Dutt Joshi**, Assistant Professor for the motivation and inspiration that triggered me for this work.

A big thanks to my friends for his support in accomplishment of my course work. They always taught me the patience and never to give up attitude in the research work.

I would like to thanks my parents for raising me, believing in me, allowing me to do things in my way and to agree with me even if they don't want. The presence of my brother and sisters is always supporting and loving in every aspect of my life

Finally, I would like to extend my gratitude to all those persons who directly or indirectly helped me in the process and contributed towards this work.

Above all I thank the Almighty God who is being with me and showers his blessings and his grace towards me in all walks of my life.

**ROOPDEEP KAUR**

**(801661020)**

## ABSTRACT

The most important aim of every arrangement of communication is to effortlessly combine the broad range of facilities of data that includes stream audio, video stream and some services of multimedia. 5G makes a significant function with many areas, information, their usage and advantages to the coming generation as compared to fourth generation. GFDM is a non-orthogonal multicarrier technique which produces inherent ISI/ICI that will affect the SER performance as compared to an OFDM system. In GFDM a single cyclic prefix (CP) is inserted for the entire block, consisting of a number of subcarriers and multiple sub symbols, whereas a CP for OFDM is inserted for each transmitted symbol. This will increase the spectral efficiency of the system. Moreover, in WM-GFDM, no CP is required, which in addition will further increase spectral efficiency. GFDM is better technique because it has low PAPR, which helps in low power consumption of mobile devices. Power spectral density (PSD) of GFDM is less this shows GFDM provides lesser leakage of energy on the side lobes which helps in reduction of OOB radiation. But for one reason GFDM is not suitable for 5G technology i.e. its complexity. It is more complex as compared to OFDM. This makes the system cheaper. A preliminary examination of implementing wavelet transforms in the context of WGFDM is carried out by using the Haar wavelet. WGFDM design model is a trustworthy candidate for future wireless needs. There is still a lot of work to be done investigating the most commonly used techniques to further reduce PAPR. Meyer wavelet has overall better spectral efficiency and low PAPR as compared to other techniques.

## TABLE OF CONTENTS

Sr. No.	Name of the Chapters	Page No.
	<i>Declaration</i>	<i>II</i>
	<i>Acknowledgement</i>	<i>III</i>
	<i>Abstract</i>	<i>IV</i>
	<i>Table of contents</i>	<i>V-VI</i>
	<i>List of tables</i>	<i>VII</i>
	<i>List of figures</i>	<i>VIII-IX</i>
	<i>List of Abbreviations</i>	<i>X-XI</i>
<i>Chapter 1</i>	<b>Introduction</b>	<i>1-11</i>
	1.1 Challenges In Migration From 4G	<i>1</i>
	1.2 Fifth Generation	<i>2</i>
	1.2.1 Necessity of 5G	<i>3</i>
	1.3 Key Technologies in 5G	<i>4-6</i>
	1.4 Filters	<i>6</i>
	1.4.1 Root Raised Cosine Filter	<i>6</i>
	1.4.2 Discrete Prolate Spheroidal Sequences	<i>7</i>
	1.5 OFDM	<i>8</i>
	1.5.1 The Block Diagram Of An OFDM System	<i>9</i>
	1.6 Modulation Scheme	<i>11</i>
	1.6.1 M-PSK	<i>11</i>
	1.7 GFDM System Description	<i>13-14</i>
	1.8 Wavelets	<i>15-16</i>
	1.7 Comparison Between OFDM And GFDM	<i>11</i>
<i>Chapter 2</i>	<b>Literature survey</b>	<i>12-24</i>
	2.1 GFDM System Description	<i>12-14</i>
	2.2 Wavelets	<i>14-16</i>
	2.3 BER Analysis of Bit Error Rate of PSK and QAM System	<i>16</i>

2.3.1	M-PSK	16-17
2.4	BER, PAPR And OOB of GFDM and OFDM System	18
2.4.1	Out-Of-Band Radiation	19
2.4.2	Peak-To-Average Power Ratio	19
2.5	GFDM In Cognitive Radio	19-20
2.6	Integration Of GFDM and OFDM System	20-21
2.7	GFDM For Cellular Networks in 5th Generation	21-22
2.7.1	Communication in Bit pipe	22
2.7.2	Machine Type Communication	22
2.7.3	Tactile Internet	23
2.8	Filtering Through Wavelets	23
2.9	Statement of Problem Based On Research Gaps	24
<i>Chapter 3</i>	<i>System Model of OFDM and GFDM</i>	<i>25-30</i>
3.1	OFDM	25
3.1.1	Fast Fourier Transform	25
3.1.2	Filter Splitting	26
3.2	GFDM	27
3.2.1	GFDM Model	27-28
3.2.2	WM-GFDM Model	29
3.2.3	Construction of Wavelets	29
3.2.4	PAPR Analysis	30
<i>Chapter 4</i>	<i>Results and Discussions</i>	<i>31-39</i>
4.1	Algorithm For Calculating Bit Error Rate	32-33
4.2	Algorithm For Calculating Peak To Average Power Ratio	34
4.3	Algorithm For Calculating Peak To Average Power Ratio of GFDM	35
4.4	Algorithm For Calculating Peak To Average Power Ratio	35
4.5	Algorithm For Calculating GFDM Spectrum	36
4.6	Algorithm For Calculating GFDM Spectrum	37
4.7	Algorithm For Calculating OFDM Spectrum	38-39
<i>Chapter 5</i>	<i>Concluding remarks, future scope and Applications</i>	<i>40</i>
5.1	Applications Of 5G Technology	41
	<i>References</i>	<i>42-45</i>

## LISTS OF TABLES

<b>Sr. No</b>	<b>Table Details</b>	<b>Page No.</b>
<i>Table 4.1</i>	<i>Parameters for transmit Spectrum</i>	36

## LIST OF FIGURES

<b>Sr No.</b>	<b>Figure Details</b>	<b>Page No</b>
<i>Figure 1.1</i>	<i>Evolution of networks</i>	<i>3</i>
<i>Figure 1.2</i>	<i>Features of 5G Technology</i>	<i>4</i>
<i>Figure 1.3</i>	<i>Time domain plot of RRC, DPSS and prototype filter</i>	<i>7</i>
<i>Figure 1.4</i>	<i>Frequency domain plot of RRC, DPSS and prototype filter</i>	<i>7</i>
<i>Figure 1.5</i>	<i>The block diagram of an OFDM system</i>	<i>10</i>
<i>Figure 2.1</i>	<i>Frame of OFDM</i>	<i>12</i>
<i>Figure 2.2</i>	<i>Frame of GFDM</i>	<i>13</i>
<i>Figure 2.3</i>	<i>Details of the GFDM modulator</i>	<i>13</i>
<i>Figure 2.4</i>	<i>Block diagram of GFDM transreceiver</i>	<i>14</i>
<i>Figure 2.5</i>	<i>Meyer scaling function</i>	<i>15</i>
<i>Figure 2.6</i>	<i>Meyer wavelet</i>	<i>15</i>
<i>Figure 2.7</i>	<i>Constellation diagram of BPSK</i>	<i>17</i>
<i>Figure 2.8</i>	<i>Constellation diagram of 16 QAM</i>	<i>17</i>
<i>Figure 3.1</i>	<i>Filter splitting</i>	<i>26</i>
<i>Figure 6.1</i>	<i>BER of OFDM using BPSK</i>	<i>33</i>
<i>Figure 6.2</i>	<i>BER of OFDM using 16 QAM</i>	<i>33</i>
<i>Figure 6.3</i>	<i>BER of OFDM using 64 QAM</i>	<i>34</i>
<i>Figure 6.4</i>	<i>CDF plot of OFDM</i>	<i>34</i>
<i>Figure 6.5</i>	<i>CDF plot of GFDM with RRC filter</i>	<i>35</i>

<i>Figure 6.6</i>	<i>CDF plot of GFDM with wavelet transform</i>	<i>36</i>
<i>Figure 6.7</i>	<i>CDF plot of GFDM with meyer RRC filter</i>	<i>36</i>
<i>Figure 6.8</i>	<i>GFDM spectrum using RRC Filter</i>	<i>37</i>
<i>Figure 6.9</i>	<i>GFDM spectrum using meyer filter with roll off factor=1</i>	<i>38</i>
<i>Figure 6.10</i>	<i>GFDM spectrum using meyer filter with roll off factor=0.5</i>	<i>38</i>
<i>Figure 6.11</i>	<i>OFDM Spectrum</i>	<i>39</i>

## LIST OF ABBREVIATIONS

OFDM	Orthogonal Frequency Division Multiplexing
GFDM	Generalized Frequency Division Multiplexing
BER	Bit Error Rate
PAPR	Peak To Average Power Ratio
PSD	Power Spectral Density
5G	Fifth Generation
GPRS	General Packet Radio Service
GSM	Global System for Mobile
AMPS	Advanced Mobile Phone Service
TACS	Total Access Communication
UMTS	The Universal Mobile Telecommunications
LTE	Long Term Evolution
FFT	Fast Fourier Transform
IFFT	Inverse Fast Fourier Transform
DWT	Discrete Wavelet Transform
IDWT	Inverse Discrete Wavelet Transform
TDD	Time Division Duplexing
HD	High Definition
ISI	Intersymbol Interference
ICI	Inter Carrier Interference

CP	Cyclic Prefix
FBMC	Filter Bank Multicarrier
UFMC	Universal Filter Bank Multi Carrier
OFBMC	Orthogonal Filter Bank Multicarrier
DPSS	Discrete Prolate Spheroidal Sequences
RRC	Root Raised Cosine
QAM	Quadrature Amplitude Modulation
BPSK	Binary Phase Shift Keying
QPSK	Quadrature Phase Shift Keying
PSK	Phase Shift Keying
MTC	Machine To Machine Communication
WRAN	Wireless Regional Area network
PAN	Personal Area Network
LAN	Local Area Network
IEEE	Institute of Electrical and Electronics Engineers
CDF	Cumulative Distribution Function

# CHAPTER 1

## INTRODUCTION

The most important aim of every arrangement of communication is to effortlessly combine the broad range of facilities of data that includes stream audio, video stream and some services of multimedia. Large number of things such as machine to machine communications, satellite, military and some more latest gadgets which are on the web of things requires avid admittance of information for the networks which is wireless. A communication system which has low latency, precision and has more rate of data that make easy us to be linked from corner to corner every part of the globe. So, to tackle with such situation, various technologies have emerged [1].

There is larger growth in wireless technology from last few years. Extensive wireless technologies, growing CD and compact disk-enabled terminals and larger accessibility of source tools which are open for age band has lead to networks which are user-centric follow-on in a necessitate for well-organized propose of networks. There is a movement from permanent cellular technology, give rise to the planning of networks and services related to Optimization. Wireless technologies have made different ways but all are having a common objective which is having concern with presentation and effectiveness. 1G satisfied the essential mobile audio communication, 2G has concern with mainly capability and exposure of area and users. The third generation paying attention for increased information rate, various services. 4G give access to various communication facilities like cell services, provides small to large movable application [2].

### 1.1 CHALLENGES IN MIGRATION FROM 4G

5G makes a significant function with many areas, information, their usage and advantages to the coming generation as compared to fourth generation. Fifth Generation will become efficient technology having no boundaries and will connect the entire globe with no boundaries. The coming generation will be more sophisticated with increasing generations in communication. 5<sup>th</sup> Generation Wireless Technology represents the advanced actual time of moveable relay communications. Comparing to fastier Internet speeds, 5G has more limit as compared to current 4G, which allows a large number of broadband clients per unit, and allows usage of unlimited information amounts in gigabytes. 5G innovative works additionally go for the Internet of things has lower cost, bring down utilization of battery and lower dormancy as compared to 4G. 5G portable technology has altered the way of usage of mobile phones having high capacity. Client never enjoyed ever such kind of high esteem technology [3].

These days' portable clients are more familiar with the wireless technology.

- Security

Reconfigurable, adaptive and lightweight safety methods should be designed.

- Infrastructure of network and Quality of service

Provides QoS confirmation to end-to-end benefits.

- User terminal has multimode

For 4G, there will be a requirement to plan a terminal which will work in different remote systems for and overcomes limitations on the time of the gadget, its usage of power and its cost.

- Hazards based on Application Level

Software applications that offers some new feature to the user but will begin latest bugs.

- Jamming and spoofing

Spoofing is sent out fake GPS signal where GPS receiver thinks that the signals comes from a satellite and calculates the undesired coordinates. Criminals use these kind of techniques. Jamming occurs when a spreader sends signals at the same frequency which the GPS signal sends [2].

## **1.2 FIFTH GENERATION**

Fifth generation wireless systems has power to handle more traffic data as compared to earlier generations. Currently it investigate study of mobile device to device networks with incremental amplify, transmit selection of antennas and forward relaying [1].

OFDM is the technique used for fourth generation, serving needs of communication for over a more than hundred years because it has ability to deal with various conditions of channel and suit recent necessities in various communication [4].

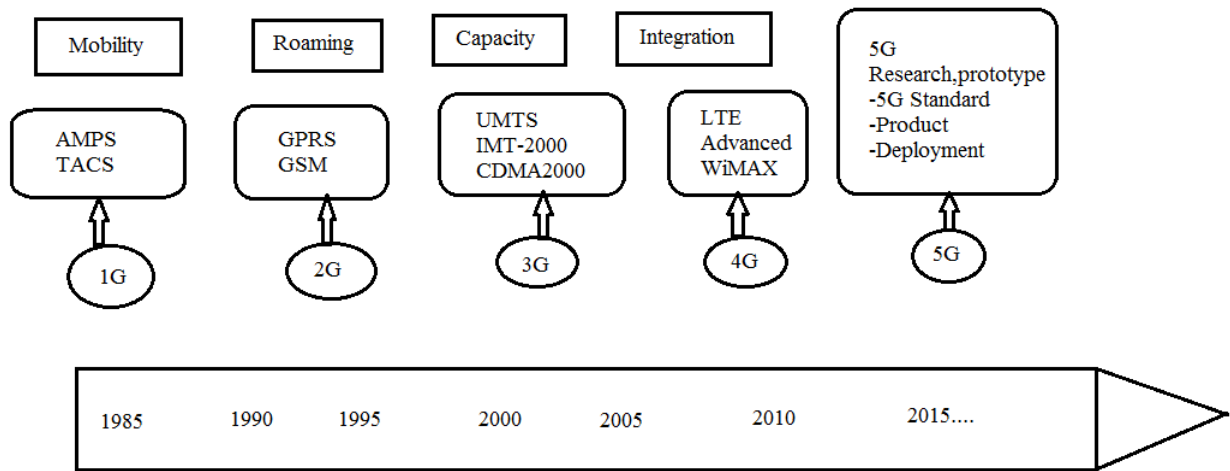

Figure 1.1 Evolution of networks [2]

In the coming year's requirement of data will be more which will not be supported by third generation and fourth generation. So, there is need of fifth generation of communication [5].

### 1.2.1 Necessity of 5G

The recent uses of 5G are downloading of more speed video, mobile communications, IoT and M2M communications, gaming.

Several requirements which are needed for fifth generation include:

- It is Capable of managing signals having more rates of data and more bandwidth.
- Have ability for transmissions that is having less latency.
- Have ability of swift switching for Time division duplex systems that are likely to be used.
- It should provide energy proficient communications.

Fifth Generation Mobile Network or basically 5G is the expected conflict of flexible improvement. The components and its use in easy way are much past the wish of a particular person. With its ultra-fast, it is suitably possible to change the importance of ease of usage of phone. With advancement in imaginative elements, your advanced mobile phone will be comparable to the portable PC.

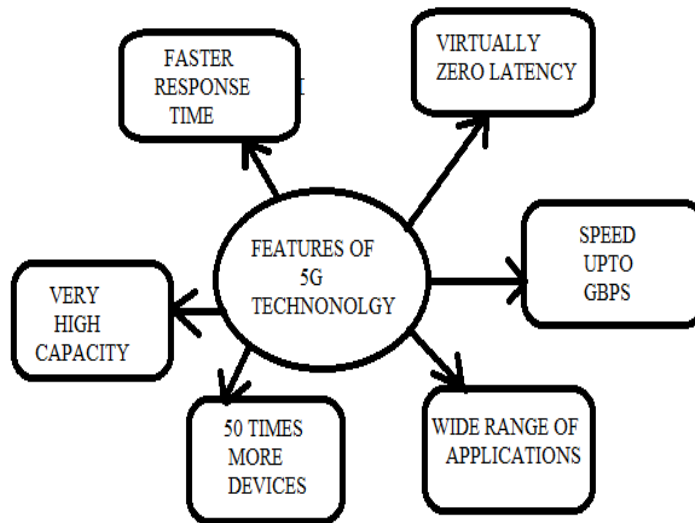

Figure 1.2 Features of 5G Technology [3]

You can utilize broadband web association; other critical components that fascinate persons are gaming choices, more widespread multimedia alternatives, network everywhere, zero inactivity, swift reaction time, and huge sound and HD video can be easily exchanged to some other device without trading off the behavior of sound and video.

### 1.3 KEY TECHNOLOGIES IN 5G

There are various kinds of key technologies in the fifth generation networks which are discussed below:

- **FBMC (Filter Band Multi Carrier)**

It is headway of OFDM which CP are not utilized but rather varieties of channels at transmitter and recipient are utilized. The advantage of this method is that it doesn't utilize CP, yet at the same time it can give an effective and preferred execution over OFDM. Thus, it is a standout amongst other adjustment systems for 5G. In this method, a channel bank is utilized by which parallel information is transmitted. By utilizing a proper model channel, the connecting spillage and limitation of recurrence can be controlled. The recurrence space of FBMC is exceptionally adaptable so it is more qualified for TVWS (Television White Spectrum) and range utilization [6].

- **OFDM (Orthogonal Frequency Division Multiplexing)**

In this, bandwidth is separated into various orthogonal subcarriers. At transmitter and receiver, it is expressed with the help of using Fast Fourier Transform and Inverse Fast Fourier Transform. This technique has more data-rate, high capability to handle users and resistant to Inter Symbol Interference. When there is division of the subcarriers, there is flat response of the channel which will made the system more efficient so that's why it is favored in 4G versatile otherwise called LTE (long haul development). Be that as it may, when we think about 5G, OFDM isn't flawless because of different inconveniences, for example, cyclic prefix (CP) and PAPR (Peak Average Power Ratio). Clamor is made when the images are so near each other. Hence, ISI is reduced due to the insertion of cyclic prefix. But it also results in wastage of bandwidth and about more than 9% of bandwidth is wasted due to CP and hence efficiency reduces. PAPR additionally broadly diminished the execution of the framework that outcomes moreover of information in subcarriers. In the event that PAPR of the framework is 20 dB then it implies that so as to transmit it to 1 dB of flag, and it needs a 20 watt of intensity that diminishes the execution of the framework. Henceforth, OFDM isn't great tweak strategy for 5G [7].

- **UFMC (Universal Filter Multi Carrier)**

UFMC depends on a channel bank multi bearer and OFDM which is thought to be ideal and novel balance plot for 5G. FBMC where separating is connected to every subcarriers, except in this procedure a sifting activity is performed on a gathering of sub-bearers. This technique proficiently decreases the side lobe that enhances the presentation of the system. It uses very short length of filter, so it is use for short burst communication. In this technique, there is division of data transfer capacity into quantities of sub groups and is allotted to the quantity of sub-bearers. At the transmitter N-point IFFT activity is performed which changes over the time space of the flag to a frequency. At collector, to changes over domain of frequency to a time space, FFT is performed [6].

- **GFDM (Generalized Frequency Division Multiplexing)**

It is non-orthogonal multicarrier strategy and is first contender for nonorthogonal waveform for 5G portable correspondence framework. In this strategy, modulation is subject to a Balian low hypothesis and by utilizing a period and frequency confined pulse, transmission is achieved. In this technique, there is reduction in the side lobe, PAPR because filtering is used for each subcarrier. At receiver, it used the Poisson summation algorithm for every symbol [8].

- **OFBMC (Orthogonal Frequency Band Multi carrier)**

It results in superior use of given bandwidth and give greater efficiency. It is little bit similar to OFDM, the allotted bandwidth is partitioned into number of subcarriers that are orthogonal to each another but the difference is that it do not use cyclic prefix. By combining spatial division multiplexing (SDM), space time block codes (STBC) and space time trellis codes (SPTC), this technique can be utilized that boost up the performance by decreasing the ISI. With MIMO techniques, interference the effect of interference of Co-Channel is more. So, OFBMC is the better method [5].

- **Quicker than Nyquist rate**

In this system, more information is sending in the time area so the limit is expanded. It utilizes direct model procedures where a pulse is sent at a speedier rate in a domain of time which brings about ISI, loss of symmetry, and so on yet by utilizing a latest discovery method, the signal can be recouped [5].

- **Cognitive Radio**

A Cognitive Radio is an intellectual system of communication which is awake of its adjacent surroundings and uses the method of accepting the surroundings and took the result. With the wireless communication system, the CR can be integrated [5].

## **1.4 FILTERS**

The communication systems which is digital is fast advancing technique which gives the faster access to information and exchange of data in great manner. The channel which is used to communicate between the transmitter and the receiver is open air medium. This channel consists of many natural phenomenon and other existing signals which are natural. When the message signals are passed through such channels the data gets attenuate and lost. This type of disturbance is called the Inter symbol Interference (ISI).In order to decrease Intersymbol interference in communication system, the pulse shaping filters are designed.

The following filters are used to reduce the intersymbol interference in OFDM and GFDM.

### **1.4.1 Root Raised Cosine Filter**

In signal processing, a root-raised-cosine filter (RRC), sometimes called as square-root-raised-cosine filter (SRRC), is frequently used in a digital communication system as the transmit and receive filter to perform matched filtering. This helps in reducing intersymbol interference (ISI).

To get reduction in ISI (Intersymbol interference), Nyquist ISI criterion should be satisfied by the transmit filter, channel response and receive filter. Raised-cosine filter is the most well-liked filter

response satisfying the Nyquist criterion. Half of this filtering is done on the transmit side and half is done on the receive side. On the receive side, the channel response, if it can be precisely estimated, can also be taken into explanation so that the overall response is Raised-cosine filter [9].

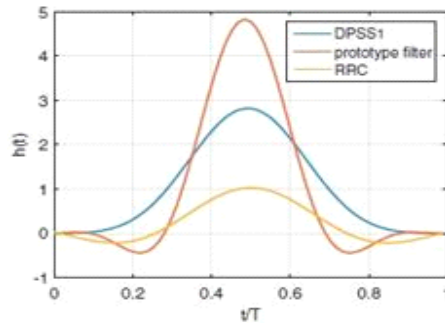

Figure 1.3 Time domain plot of RRC, DPSS and prototype filter [9]

#### 1.4.2 Discrete Prolate Spheroidal Sequence

Digital prolate spheroidal sequence (DPSS) is a window having maximal energy concentration in the main lobe and minimum at the side lobes. It maximizes the energy in the main lobe of the window as compared to total energy.

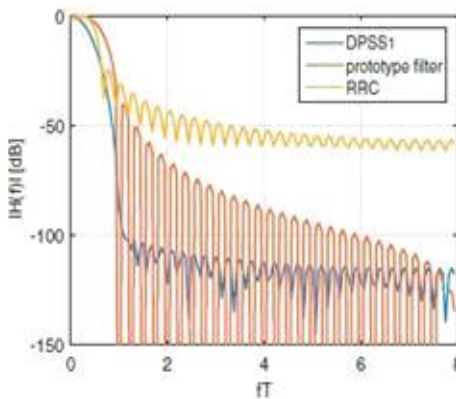

Figure 1.4 Frequency domain plot of RRC, DPSS and prototype filter[9]

This gathering of pulse molding channels is characterize by the raised cosine (RC) and root raised cosine (RRC) works in time-space having roll off factor  $\alpha$ . Here, this time-domain articulation comes about by trading the free domain of frequency to the time variable.

$$g_{RC}(t) = \begin{cases} 1, & |t| \leq \frac{(1-\alpha)T}{2} \\ \frac{1[1+\cos(\pi P_{RC}(t))]}{2}, & \frac{(1-\alpha)T}{2} < |t| \leq \frac{(1+\alpha)T}{2} \\ 0, & \text{otherwise} \end{cases} \quad (1.1)$$

Where  $P_{RC}$  is the inner argument of the cosine which can be expressed as

$$P_{RC} = \frac{\left(|t| - \frac{(1-\alpha)T}{2}\right)}{\alpha T} \quad (1.2)$$

By including the Meyer auxiliary function  $v(x)$ , the inner argument of the cosine will be changed as

$$P_{RC} = \frac{v\left(|t| - \frac{(1-\alpha)T}{2}\right)}{\alpha T} \quad (1.3)$$

The Root raised cosine filter is written as

$$g_{RRC}(t) = \sqrt{g_{RC}(t)} \quad (1.4)$$

Where RC is raised cosine filter and RRC is root raised cosine filter [10].

## 1.5 ORTHOGONAL FREQUENCY DIVISION MULTIPLEXING (OFDM)

OFDM is the technique used for fourth generation which is providing needs of wireless communication from ten years because of its potential to deal with various conditions of the channel and to fulfill latest demands of non wired communication.

Though there are many advantages provided by OFDM, but it is not capable of serving the future requirements because it has some shortcomings. It has High out-of-band (OOB) side flaps; it is because of the channel subcarriers which are rectangular, Inter Carrier Interference (ICI), Inter Symbol Interference (ISI), high Peak-to-Average Power Ratio (PAPR) and long round excursion delays. Numerous endeavors are made to beat these downsides yet it is still doubtful whether OFDM or altered variants of this procedure will ready to contend with the requests of future applications or not [4].

Still there is no official 5G standard, the examination network is finding and seeking more multicarrier adjustment strategies. There is large growth in the wireless communication and there is requirement of a modulation technique that will able to transmit high data rates at high bandwidth efficiency. The problem of the intersymbol interference (ISI) produced by the frequency selectivity of the channel became more concerning fact. Adaptive equalization techniques can be used at the receiver side in order to combat the ISI effects, but in real time conditions it is very difficult to operate at several Mb/s with compact, low-cost hardware. OFDM is a method which eliminates the requirement of very complex equalization. In a prior serial information framework, the images are transmitted serially, one by one, with the frequency range of

every symbol of data involve the whole given data transmission. There are awesome possibilities that the frequency specific channel reaction influences in an extremely particular way the diverse spectral segments of the information symbol, consequently presenting the ISI. A similar method, respected in the time domain comprises in spreading of data symbols such, the vitality of one symbol mix with the vitality of alternate images, such that got signal has a high likelihood of being inaccurately translated. Normally, one can accept that the channel frequency selectivity can be relieved if, we transmit the information at the same time as opposed to transmitting a one high rate information stream, on a few tight band sub channels, in which there is flat frequency response of the channel. So, when we increase the subcarriers it decreases the rate of information that every particular carrier carries which lengthen the symbol duration on each subcarrier. The frequency-selective channel response and the having flat response on each sub channel means that there is reduction in Intersymbol Interference. This is the main secret about the OFDM. When the data is sent over a greater number of jointly occurred subcarriers, it results in frequency division multiplexing.

OFDM will provide much higher bandwidth efficiency as comparison to the classical frequency division multiplexing technique. Because in OFDM the spectra of individual subcarriers can overlap each other. In fact, the carriers are carefully chosen so that they can be orthogonal to each other. As we know that, the orthogonal signals do not interfere with each other and they can be separated at the receiver [7].

### 1.5.1 The Block Diagram of an OFDM System

The information in the input is baseband modulated with the help of a modulation scheme which is digital. A variety of modulation schemes can be used such as BPSK, QPSK (also with their differential form) and QAM with different signal constellations. There are also forms of OFDM where a distinct modulation on each sub channel is performed .Also, data can be encoded in frame, on the serial data ,the baseband signal modulation is performed, which is called, DFT frame, or inter frame [4].

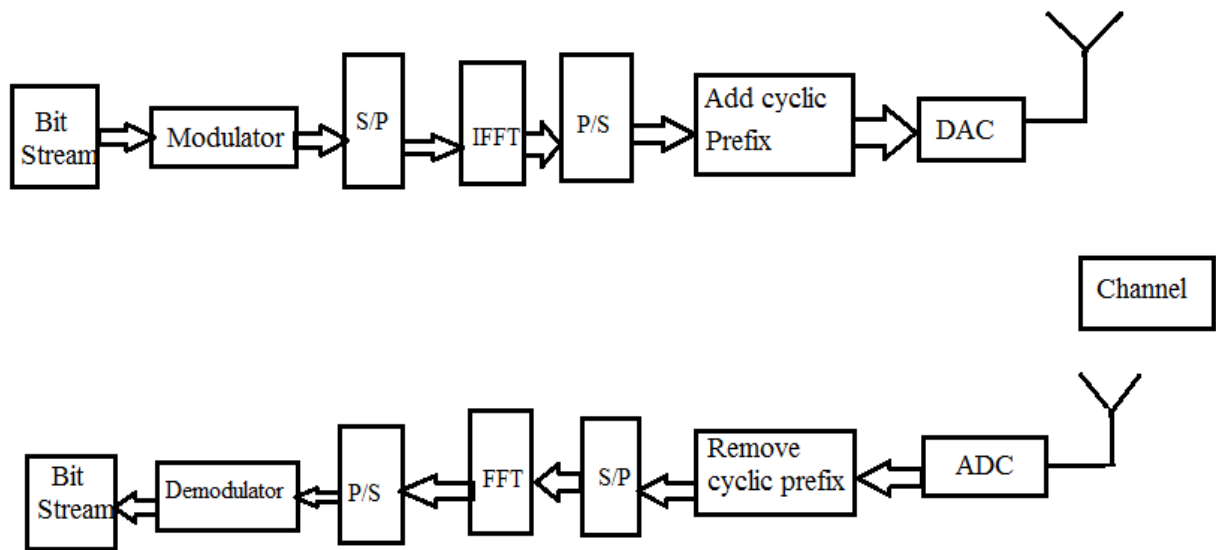

Figure 1.5 The block diagram of an OFDM system [4]

In  $N$  different sub streams, the data symbols are parallelized. Through the IFFT modulation block, each sub stream will take a different carrier, which is the key element of an OFDM system. In order to remove the inter-symbol and inter-block interference (IBI), cyclic prefix are used. The cyclic prefix of length  $L$  is a circularly extended version of the IFFT-modulated symbol, which are get by aping the end  $L$  samples of the symbol in the side of front. The information is then converted, forms a symbol that helps in modulating a carrier which is of high-frequency across the channel. The channel which is used is called as a linear time-variant system [10].

In the receiving part, the totally reverse procedures occurred, the data is firstly down-converted to the baseband and after that there is removal of cyclic prefix. The exact form of transmitted symbols can be retrieved by coherent FFT demodulator. The data is converted serially and there is need of demodulation scheme which will be utilized to guess the symbols which are transmitted.

OFDM is a very good method widely used in wireless communications as well as in many modern communications. However, it has some disadvantages like sensitivity in ICI (Inter-Carrier Interference) and a high PAPR (Peak-to-Average Power Ratio). Also, the CP (Cyclic Prefix) is not so much effective in the spectrum and it does not work well when the division of delay in the channel becomes greater than the CP length, which will result in ISI .In order to improve these shortcomings, a variety of techniques have been planned .

## **1.6 MODULATION SCHEME**

Modulation is the method by which one varies some feature of a periodic wave by a high frequency signal. It is used to send an information bearing signal over long distances. These type of high frequency carrier signals can be transmitted over various medium which are the transmitted lines or air so that they are capable of covering long distances. The carrier signal can be of any type, it can be an electrical current, a radio or microwave frequency signal or light. The process of getting the data at the receiving end is called demodulation. The characteristics of the carrier signal like amplitude, frequency, or phase are varied in accordance with the modulating signal. This baseband signal is also known as the modulating signal. This baseband signal is a varying slowly as compared to the rapidly varying carrier frequency signal.

## **1.7 COMPARISON BETWEEN OFDM AND GFDM**

Generalized FDM (GFDM) is characterized by less out of band emission. To achieve better spectrum and energy efficiency, GFDM is very beneficial which does the dynamic adoption of pulse shaping optimizing on time and frequency on fading channels. GFDM transmit multi-symbols per multi-carrier in a time and frequency. By circularly convolving each individual sub-carrier with a pulse shaping filter, the block structure is achieved. Pulse shaping filters enables less radiation in the stop band. To control leakage in the stop band for small values of CPs, windowing schemes in time can be applied to a GFDM block. Orthogonality between the sub-carriers can be removed by Variable pulse shaping filters. It results in ISI and ICI. GFDM has simplest transmitters, parting to the side synchronization actions and dropping signaling load. These uniqueness of GFDM, alongside with the idea of processing of shifting at base stations as much as possible, can results in decrease of energy spending. This is not possible in case of OFDM because of synchronization pulse leakage and precise synchronizing necessities so that orthogonality between the sub-carriers remains as it is. As an overview of OFDM, when the number of symbols for sub-carriers is one, GFDM fits with it [10].

## CHAPTER 2

### LITERATURE SURVEY

Thorough analysis of literature review is essential for the productive and good research work. Literature review is acquiring an author's phenomena, methodology and history. It helps to understand the evolution of technology.

#### 2.1 GFDM SYSTEM DESCRIPTION

Generalized Frequency Division Multiplexing is technique of modulation to serve the future wireless needs of communication system. It has block structure in which each frame consists of sub symbols of  $M$  and  $K$  subcarriers which represents total number of  $KM$  symbols. This superior modulation scheme has block based structure which has many advantages as comparison with OFDM. There are many factors due to which it is better than OFDM. It has lesser side lobes, cyclic prefix are efficiently used between frames of GFDM [11].

GFDM is very flexible multicarrier technique. If we start comparing GFDM with OFDM block by block it clearly depicts that there is not much difference between GFDM and OFDM except A matrix but when we go deep inside the system, we monitor that there are some differences in GFDM. As we seen when bits are coming in the modulation block one can do analogous operation as like of OFDM which is we do in Quadrature Amplitude modulation (QAM). After modulation the main difference is an A matrix block. Here, A matrix is transmission matrix that has sub symbols and sub carriers. Input bits are changed into streams of information which are equal to  $M \times K$  where  $M$  represents sub carriers and  $K$  are the sub-symbols. GFDM have time slots which are  $M$  and for each time slot we have sub carriers which are  $K$ . After GFDM modulation block , CP are added which are of exact length as of OFDM but in GFDM,CP are inserted after every frame to avoid IFI but in OFDM, CP are added across two time-slots as shown in the given below . Then through channel, the signal is passed. Firstly cyclic prefix are removed then we do GFDM demodulation.

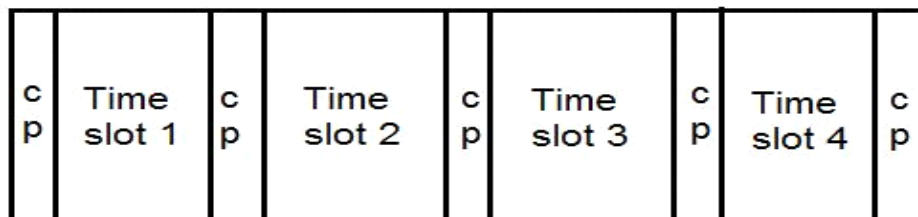

Figure 2.1 Frame of OFDM [11]

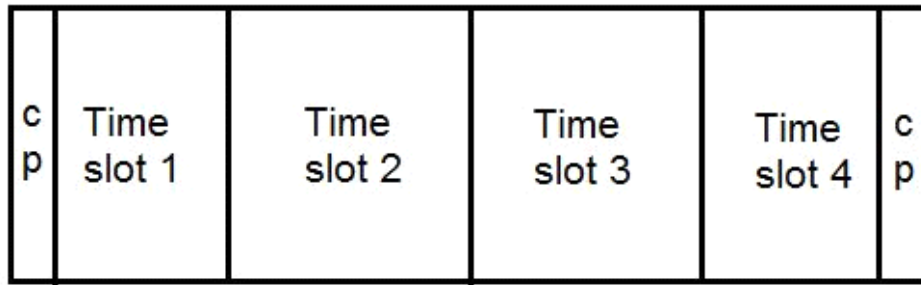

Figure 2.2 Frame of GFDM [11]

GFDM has modulation of free blocks, in which every block has some subcarriers and sub symbols. With a prototype filter, the subcarriers are filtered that are shifted circularly in the domain of time and frequency. It helps in reducing the out of band emissions, efficient power spectral density spectrum. Due to filtering of the subcarrier it not remains orthogonal and results in intersymbol and inter- carrier interference. Although, proficient techniques able to decrease this interference [12].

It has same bit error rate as compared to orthogonal frequency division multiplexing. GFDM is a good technique for the fifth generation physical layer because it is very flexible which can handle the various needs. In real time applications, to fulfill latency requirements the signal length must be reduced [11].

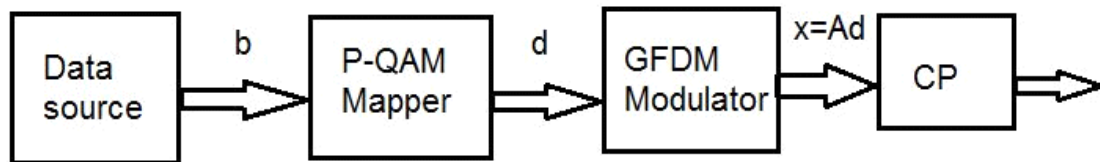

Figure 2.3 Details of the GFDM modulator [11]

GFDM is limited in a structure of block having total number of  $MK$  samples, where  $K$  number of subcarriers has  $M$  sub symbols each, to match the time constraints of low latency applications; we can design the structure of time and frequency. Various filter impulse responses can help in filtering and this method affects the out of band emissions and the bit error rate. As, GFDM has signals in both domain of time and frequency. Thus, this method has all the good points of OFDM but it has complex structure. In block of GFDM, the operating cost becomes small because single CP is added for multiple sub symbols. It improves the spectral efficiency of the system.

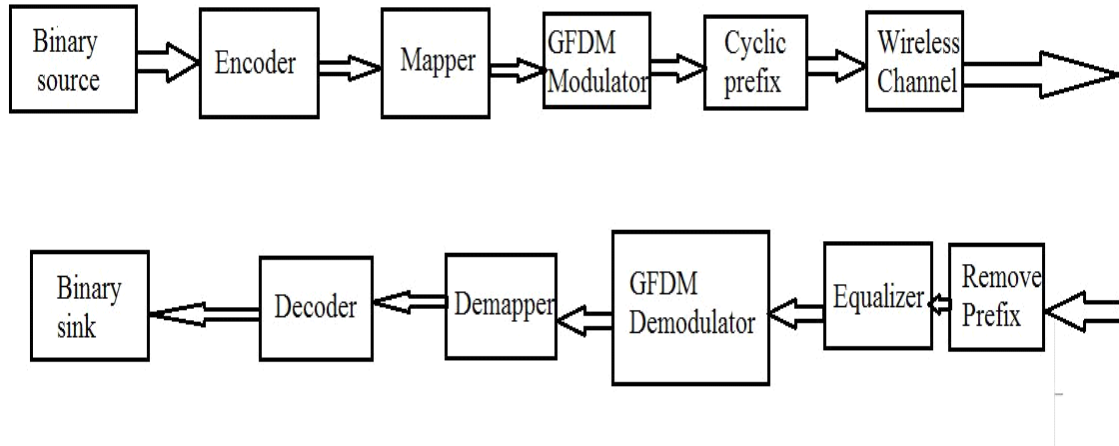

Figure 2.4 Block diagram of GFDM transceiver [11]

In the block diagram shows in Figure 2.4. A source of information has data vector denoted by  $\mathbf{b}$ , that is encoded and after encoding we get  $\mathbf{bc}$ . Data block is represented by vector  $\mathbf{d}$  which has  $N$  elements and has  $K$  number of subcarriers and having  $M$  subsymbols. The overall symbols becomes  $N = KM$ . Modulo operation defines the circular shift in domain of frequency.

Still some shortcomings of the GFDM design are there that are high Peak to average power ratio. If we increase the roll-off factor  $\alpha$  linked with the filters utilized in GFDM it depletes the efficiency of channel. So we should use orthogonal subcarrier rectangular filters should not be used because they have very limitations. Research is going on, on the discrete prolate spheroidal sequences or Multi tapers. The windows should not be non orthogonal to each other [13].

The Discrete prolate spheroidal sequences are the best windows in the domain of frequency which maximizes energy of signal in the required frequency band.

Their shortcoming is that they are finding in a very difficult manner. We planned a Wavelet based technique which uses an Inverse Discrete Wavelet Transform block rather than Inverse fast Fourier transform. This kind of approach is very efficient [14].

## 2.2 WAVELETS

A wavelet is having zero average value which is of limited duration. Sinusoids which theoretically have range from minus infinity to plus infinity but wavelets have some starting point and ending point. The basic criterion in the wavelet transform is to indicate a random function which is combination of a set of some wavelets or it may be some basis functions. Mother wavelet is wavelet through which we can obtain basis functions or baby wavelets which are done by contractions and shifts. Wavelets has good orthogonality and it has also have solid localization in time and frequency domain [12].

The working of wavelet transform is as follows: The output of the High pass filter results in detailed coefficient and Low pass filter results in the approximation coefficient. Approximation coefficient and detail coefficient are the part of signal which is partitioned by the wavelet transform. Firstly, DWT decomposes the signal into approximation information and detailed information then it presents the signal at various bands of frequency having different resolutions. The signal is firstly crossed across the HPF and LPF. A half band LPF is able to deplete every frequencies which are more than one half of frequency having highest value and a half-band high pass filter removes all frequencies that are less than half of the highest frequency. Resolution becomes half in the low pass filtering, but scale does not change. Then after that, sub sampling of scale is done by a factor of two because half samples become redundant.

The benefits of using wavelet transform are that the wavelet properties have overlapping nature, so the wavelet based GFDM donot require cyclic prefix. So, it is highly spectral efficient than that of Fourier-based GFDM [15].

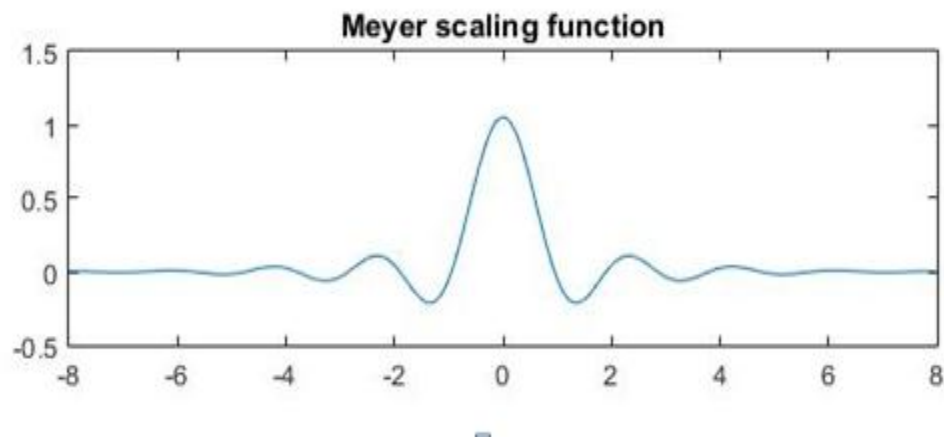

Figure 2.5 Meyer scaling function [16]

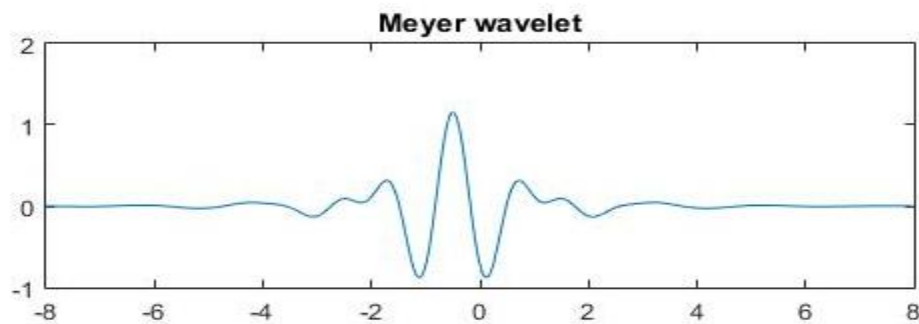

Figure 2.6 Meyer wavelet [16]

The Meyer wavelet is a wavelet which is orthogonal that was proposed by Yves Meyer. As a type of a continuous wavelet, it has been applied in a number of cases, for example it is used in adaptive filtering. Different ways are there to defining this auxiliary function, which yields variants of the Meyer wavelet. In the domain of time, the waveform of the Meyer mother-wavelet has the shape as shown in the following figure [17].

## 2.3 ANALYSIS OF BIT ERROR RATE OF PSK AND QAM SYSTEM

OFDM is a way of encoding of data on various carrier frequencies. Over parallel sub-channels the data is sent having every channel modulated by a different types of schemes of modulation. OFDM has ability to cope with various channel conditions as in comparison with the modulation scheme which is having single carrier and maintain the same data rates of earlier scheme having the similar bandwidth. Also, equalization of channel simplifies since OFDM used many signals which are narrow band but not one wide band signal. The less symbol rate uses the guard bands among symbols in order to reduce Intersymbol Interference [18].

### 2.3.1 M-PSK

In Phase-shift keying (PSK) modulation scheme, information of modulating signal is conveyed by changing of carrier wave's phase. BPSK is a simplest form of M-PSK which is called binary digital modulation scheme. Binary data is given by the carrier waves, which is written as follows [18].

$$S_0(t) = A \cos 2\pi f_c t, \quad 0 \leq t \leq T_b \quad (2.3.1)$$

Here A represents amplitude which remains constant,  $f_c$  is frequency of carrier and  $T_b$  is the time period of bit. Suppose bit energy is written as  $E_b$ , expressed as:

$$S_0(t) = \sqrt{\frac{2E_b}{T_b}} \cos 2\pi f_c t, \quad 0 \leq t \leq T_b \quad (2.3.2)$$

$$S_1(t) = \sqrt{\frac{2E_b}{T_b}} \cos 2\pi f_c t, \quad 0 \leq t \leq T_b \quad (2.3.3)$$

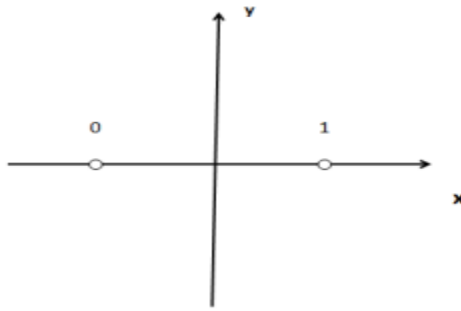

Figure 2.7 Constellation diagram of BPSK [18]

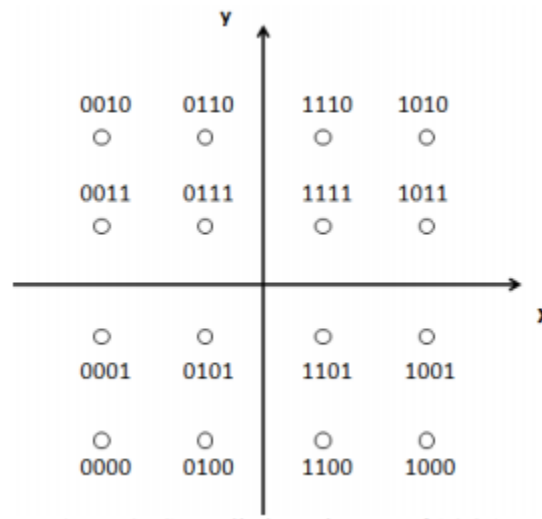

Figure 2.8 Constellation diagram of 16 QAM [18]

In Quadrature Amplitude Modulation, the components which are in-phase and quadrature are not dependent.

$$P(e | MQAM) = 2 \left(1 - \frac{1}{M}\right) \operatorname{erfc} \left(k \sqrt{\frac{E_s}{N_0}}\right) - \left(1 - \frac{2}{\sqrt{M}} + \frac{1}{M}\right) \operatorname{erfc}^2 \left(k \sqrt{\frac{E_s}{N_0}}\right) \quad (2.3.4)$$

M can be raised power of 2. Through this, probability of M-ary modulation can be finding. The OFDM system was simulated to check out the presentation of various techniques of modulation .The main parameter was BER to check the performance of any system. The Bit error rate v/s Signal to noise ratio plot for various techniques of modulation reveals that if we increase BER then SNR also increases with it, for higher order modulation schemes. But, the modulation schemes which is having low order for

example BPSK and QPSK has less BER at receiver. So lower order modulations are more efficient techniques in terms of BER and SNR [18].

## **2.4 BER, PAPR AND OOB COMPARISON OF OFDM SYSTEM AND GFDM SYSTEM**

GFDM is a concept of digital that maintains OOB radiation with the help of filters which are pulse shaping. GFDM have less out-of-band radiation (OOB) and has also less peak-to-average ratio (PAPR), but these features are not available in the OFDM. They gives justification of the GFDM system model, the performance of GFDM in terms of OOB emissions, PAPR and BER and compares it with the OFDM. There is swift advancement in communications from last few decades. For example, the needed peak data rate for IMT-advanced reached 100Mbit/s for applications having more mobility and 1Gbit/s for applications having less mobility. It becomes very important to give connectivity. So there is need to develop technologies having less complexity which facilitates flawless handover over various standards in different environmental conditions whether it is indoor or outdoor, or any rural area, urban or sub-urban areas. Multicarrier techniques are using so widely for communications. At present, OFDM is mostly used for communication because of its strength against channels of multipath. But, the next generation will demand higher data rate, low power consumption and having less response time. The application scenarios which will use for 5G communication having some compromises which OFDM cannot compete. MTC and machine to-machine (M2M) communication keeps the strict synchronization procedure so the orthogonality remains as it is among subcarriers because it require low power consumption. For Tactile Internet, low latency is required and V2V applications require short data, which means that OFDM signals could not able to fulfill the demands of machine to machine communication and tactile internet. OFDM has also less efficiency of spectrum due to the insertion of cyclic prefix which is not good for WRAN purpose, in which the impulse response of channel has very less duration of microseconds. Also, OFDM has high OOB emission which is not good for dynamic spectrum. So, an alternate multicarrier modulation scheme is required which will fulfill the required demands. GFDM, may be able to fulfill the demands of fifth generation networks. GFDM is the modulation of blocks which are independent, in which every block has some subcarriers and sub symbols. With the help of prototype filter the subcarriers are filtered which are shifted circularly in domain of time and frequency. OOB is reduced by this method, reduces intersymbol and intercarrier interference [19].

OFDM is widely used in various technologies. But still it has some shortcomings like ICI and PAPR. Also, the CP are also not much efficient and does not becomes efficient when the length of CP becomes less than the channel delay spread, which results in ISI. To overcome these shortcomings various methods have been investigated, first are the techniques which keeps the OFDM layout as it is and techniques

which decreases intersymbol and intercarrier interference. The ICI/ISI approach comes in GFDM. GFDM has better presentation as compared to OFDM [20].

#### 2.4.1 Out-of-Band Radiation

Rectangular pulse shaping filter is used in filtering in case of OFDM. Hence its range of power spectrum is infinity. The mean energy in the OOB and the mean energy ratio is called out of band emission. The reduced out-of-band energy has less intersymbol interference. The important concerns of OFDM based system is High value of PAPR. A range of changes has been made to original OFDM system. In OFDM, there is one symbol per subcarrier, so it has high PAPR. In GFDM, PAPR reduces because in case of GFDM,  $M > 1$ .

GFDM spectrum is very better as compared to OFDM spectrum. Also GFDM has low out of band radiation.

Attenuation of side lobes for GFDM system is 10-15 dB less as compared to OFDM signal. The out of band can be additional compacted by putting Guard bands in case of GFDM. Insertion of guard symbol results in less OOB [20].

GFDM has better OOB emission as compared to OFDM, because the subcarriers numbering for two waveforms are not same [19].

#### 2.4.2 Peak-to-Average Power Ratio

The Peak-to-Average Power ratio is calculated in terms of the cumulative distribution function. When probability of the average power level is below some certain threshold is called CDF. GFDM is a scheme in which there is reduction in the out of band radiation and Peak to average power ratio as in comparison to OFDM, so GFDM become more suitable for fifth generation. Raised cosine and Root raised cosine filters are mostly used as filters for pulse shaping in GFDM .However, the deprivation of bit error rate can be compensated using suitable orthogonalization techniques [20].

It can be concluded that GFDM is spectrum efficient as compared to OFDM, it is all due to the root raised cosine pulse shaping filters that has been used and efficient spectrum can be seen in GFDM. In addition, channel distortions are there which were caused by Additive white Gaussian noise for different SNRs. Also in the additive white Gaussian channel, GFDM provides better results in comparison to OFDM [21].

### 2.5 GFDM IN COGNITIVE RADIOS

GFDM is a latest multi carrier technique which gives less OOB radiation, so it becomes more efficient method for physical layer of cognitive radios. In WOFDM, cyclic prefix are not needed so it is an

efficient technique [22]. Also, Doppler shift rarely affects WOFDM. In WOFDM, orthogonality is provided by a prototype wavelet filter. Phase linearity is also provided by Wavelet and it has also less out-of-band rejection. GFDM based cognitive radio receiver gives best sensing performance [23].

For designing a multicarrier physical layer, the multiband Generalized Frequency Division Multiplexing is very good techniques. GFDM is very good technique for a cognitive radio modulation because pulse shaping filters has very less OOB. FBMC is also a good method for CRTVWS transmission, but if we made comparison between FBMC and GFDM, the earlier one is outdated. GFDM has very stretchy filters which are RRC filters as in comparison with OFDM that has not RRC filters that causes more adjacent band interference which degrades the bit error rate performance. But one solution is successive interference canceller which can reduce the ICI thus it improves the performance of GFDM [24].

If generalized frequency division multiplexing is used for the transmission of CR TVWS, it is suitable that we should use the GFDM receiver for other CR signals as a sensing device. Conclusion depicts from this is that complementary ROC curves for GFDM are more efficient as compared to OFDM and also in an asynchronous cognitive radio system GFDM sense in a best way as comparison to OFDM [25]. Research is going on the theoretical performance of asynchronous detection. ROC characteristics of a conventional OFDM system are improved by using a GFDM receiver as a sensor. So simulation results betterly prove that GFDM is very good method for cognitive radio PHY rather than conventional OFDM. GFDM has best sensing characteristics as well as best spectral shaping [26].

## **2.6 INTEGRATION OF A GFDM AND OFDM SYSTEM**

Concepts of cognitive radio aim at improving the spectrum utilization efficiency by exploiting locally and temporally empty portion of the spectrum. While considering hierarchical spectrum access, secondary users have permission to use white spaces of spectrum on a noninterfering basis, but the primary systems should have minimal impact that is to be ensured. To handle the spectral properties of the transmitted signal, pulse shaping filters are used. In this, two setups of uncoded AWGN transmission are analyzed through simulation. Both setups have the same thing that an OFDM primary system is overlaid by a secondary system. Resources are made free artificially for that purpose. First, a non synchronized OFDM system is put into the white space. After that the final results are made compare to the secondary GFDM system. Both setups are checked in order to check bit error performance, dependence of guard bands and different parameters of pulse shaping filter.

GFDM is a modulation technique which maintains OOB with the help of pulse shaping filters .It uses the raised cosine (RC) and root-raised cosine (RRC) filters for this purpose. Due to the Sharp edges in frequency domain response there is greater spread of the signal. So an efficient FFT based equalization is required. So there is need of transmit and receive filter at the cyclic prefix. However, CP is pure

redundant, from the information theory point of view while from energy efficiency point of view it power need increases with increase in bits. So it should be kept minimal. Tail biting (TB) filters maintain the length of the CP the same as in OFDM [27].

If we compare the OFDM and GFDM secondary system regarding their effect on the BER of the primary OFDM technique. Then the conclusion is that GFDM secondary system produces less interference to the primary system as in comparison with synchronous OFDM system [8].

Our main goal is the protection of primary system. GFDM secondary system has better results as in comparison with the OFDM secondary system. For pulse shaping, raised-cosine filters are better than root raised-cosine is and a small roll-off factor also good for the primary system. As the roll off factor increases, the system becomes more degradable. Through tail biting, cyclic prefix length should be independent from the length of filter, and this technique takes the performance of GFDM nearer to OFDM. GFDM employs a larger block size per cyclic prefix compared to OFDM and this may effect in the procedure of the equalization. In communication there are so many limitations regarding power consumption and complexity of the transceiver design. If GFDM is applicable in those, studies and optimization regarding those aspects are necessary [27].

## **2.7 GFDM FOR CELLULAR NETWORKS IN 5TH GENERATION**

The 4G Cellular systems have been precised for providing more speed of data rates. The next generation Cellular systems will look for more various application requirements i.e. 4G capabilities demand for higher data rates; ultra-low power consumption is needed for battery-driven communication sensors ; very short response times is required for control applications [28]. Analysis for the major properties of the given waveform and related points are highlighted in this paper. After listing the values of GFDM, it is beneficial in the given listed fields:

- Way for manufacturing the spectral properties of waveform.
- Symbol error analysis over wide channel models.
- MIMO-GFDM concepts in achieving diversity.
- The brilliant spectral properties of the waveform are preserved by preamble-based synchronization.
- Iterative receivers are used for channel coded GFDM transmission to check bit error rate presentation.
- Concept's proof for GFDM and realization part of the sample using platforms of hardware presented in modern world.

In review, the comfortable environment of GFDM provides the waveform an appropriate aspirant for outlook for fifth generation communication [29].

The scenario for future 5<sup>th</sup> generation networks has necessities that walk off ahead of advanced data rates. [30]. The application scenarios measured in this slice are:

### 2.7.1 Communication in Bitpipe

At present various services are there, where internet is used for broadcasting television and radio content. People require their favorite shows wherever, and to access this content smartphones and tablets are normally used. With the resolution in screen on mobile devices ahead of high definition, several tens of Mbps is required for achieving a good Quality of Experience (QoE) of videos and 3D contents. So, advanced digital communication technique are needed by the next generation networks. For waveform production, fragmentation in cognitive radios (CR) are crucially done by the low out-of-band emission. The emission mask without additional filtering will barely be able to attend for OFDM with  $-25$  dB OOB emissions, which renders its use in the coming generations. OOB emission can be achieved a number of dBs below OFDM and, therefore vacant and fragmented spectrum is extra suitably explored. In addition the low OOB emission. The spectrum efficiency can significantly be improved and the effect of the Cyclic prefix length is minimized with large  $M$ . Without increasing the interference between cells, transmission can enlarge the recycle of spectrum by combining the GFDM with Coordinated Multipoint [31,32].

### 2.7.2 Machine Type Communication

Sensors are equipped in machines, devices and even objects which make them intelligent and allow them to operate autonomously and to be in touch without human interface. Whereas today's MTC is dependent wireless technologies which are of less range, it is predictable that mobile systems will gain a significant market share by providing wide area coverage. Two main markets were there for MTC. The principal considers machines as entire frameworks with just an interface which grants for taking care of it over the Internet. Alternate considers machines as sensors and actuators where the entire control framework is to be enthused to a cloud foundation. Despite the fact that the main approach can be actualized without further ado, the second approach is considered as the most intriguing in light of the fact that the exact data will be given by the associated sensors to Big Data preparing, permitting reveal examples and relationships for information investigation, and provide good services. Take a system, where communication is between the active devices which not involve man's interference. Cellular networks that are connected to MTC devices cannot go across every steps of synchronization, because a large amount of energy is consumed in this process. Hence, a reliable communication will able to be achieved in MTC devices with a loose synchronization. Loose time domain synchronization is allowed for large CP

and CS in a random access channel, but this approach cannot be proficiently used with OFDM as one CP and CS per symbol is required. One CP and one CS in a block is applied with GFDM with several subsymbols. Therefore, a LTE resource block can be planned as a GFDM block with CP and CS big enough to accommodate timing misalignment (see Figure 16). It is worth noting that the size of the CP is increased by GFDM and introduced a CS without consuming further resources when compared with the LTE approach [33].

### 2.7.3 Tactile Internet

This new application situation is first imagined in, where the constant control applications utilize the 5G connect with dormancy necessity at most 1 ms round-trip. The regular connection idleness is required for the low inertness which decides the material guiding and control genuine and virtual items. Indeed, a touch screen is utilized by the greater part of the present cell phones as input interface. Some latest boundary devices are available to interact with the surroundings. If between the command insertions, the round-trip delays too large, the environment action and it gives a bad quality of service or even cyber sickness. Since delay of more than 1 ms in the in general round-trip framework can't be bigger, the physical layer time spending will be of close to many  $\mu$ s. The present casing structure of Long Term Evolution (LTE), has an inertness that is no less than one request of extent over the objective for the Tactile Internet based on 70 $\mu$ s OFDM symbols. This application is addressed by GFDM having a small MK product. Larger bandwidth per subcarrier will be leaded by this approach [23].

## 2.8 FILTERING THROUGH WAVELETS

A little portion of a continuous signal is called a wavelet. In Discrete wavelet samples are discretely sampled and it gives information regarding both domains of time and frequency. In wavelet Transform signal is decomposed into more wavelets with the help of mother wavelet function and the orthonormal basis function. There are two filters in the DWT which includes both LPF and HPF filters. Approximated coefficients are given by LPF and by high pass filter gives detailed coefficients. DWT decomposes the signal into an estimate information and detailed information then it present the given signal at various bands of frequency with various precisions. The signal is firstly crossed through HPF and LPF. A half band LPF is able to deplete the frequencies which are more than half of the frequency which is highest and a high pass filter which is half-band deplete all frequencies that are less than half of the frequency which is highest. Resolution becomes half in the low pass filtering, but scale does not changes. Then after that, sub sampling of scale is done by a factor of two because half samples becomes redundant. The DWT-OFDM has a very huge benefit as comparison with the FFT-OFDM and the performance parameters are also able to prove this phenomenon. Particularly, the Haar wavelet having BPSK modulation is very efficient [34].

Wavelet transform is a tool which is used to study signals in the both time and domains of frequency. Wavelets has dense localization in both time and frequency domain, and have good orthogonality. In WOFDM, cyclic prefix are not required. CP is having proportion 20% or more than that. So wavelet based OFDM is 20% more efficiency. Also, WOFDM is rarely affects by Doppler shift. Wavelet gives linearity of phase and large out-of-band rejection.

OFDM based on wavelets is a very simple technique, and in this, only filters are needed which is having low order so it has a low complexity as and also filter type can be chosen according to need because special filters will produce different outputs. If we compare DFT based OFDM system and WOFDM system, WOFDM system is more efficient .WOFDM system has much better Power spectral density as compared to conventional OFDM system [35].

## **2.9 STATEMENT OF PROBLEM BASED ON RESEARCH GAPS**

From the literature reported above following gaps have been observed:

- Orthogonal Frequency Division Multiplexing is the technique having multicarrier modulation which is used for 4G, it has very advantages but it is not able to fulfill the future requirements due to some effects.
- Out-of-band (OOB) radiations are very high.
- Has Interference in the inter carrier (ICI).
- Suffers from Inter Symbol Interference (ISI).
- Suffers from high Peak-to-Average Power Ratio (PAPR).
- Long delays in the round trip.
- GFDM also has high PAPR.
- Also when we Increase the roll-off factor ' $\alpha$ ' linked with the RRC filters which are used in GFDM, degrades the efficiency of GFDM system.

## CHAPTER-3

### SYSTEM MODEL OF OFDM AND GFDM

Model of OFDM and various types of models of GFDM, wavelet based GFDM are as follows:

#### 3.1 OFDM

OFDM is a combination of two methods, modulation and multiplexing. FDM divides the given bandwidth into different subcarriers that do not overlap each other, but the subcarriers overlap with each other due to orthogonality in the OFDM which gives high spectral efficiency. By FFT, this OFDM technique can be implemented effectively but it has few shortcomings such as a very high PAPR and with the help of Cyclic Prefix, we can decrease the Inter Symbol Interference (ISI), but it also decreases the efficiency of spectrum. We go for the DWT, in order to overcome the given disadvantages. OFDM gives a proficient way to grip more speed streams of data. In Conventional OFDM FFT filters were used for modulation and demodulation. Wavelet filters has better spectral properties so DWT based OFDM systems have better performance [34].

##### 3.1.1 Fast Fourier Transform

It is the famous transform which is used to get frequency spectrum of signals. It is an algorithm through which the Discrete Fourier Transform in a faster way and with reduced complexity. It is best suited for signals in which frequency components do not change with time. The data generator consists of series of data and it is modulated with the help of M-PSK or M-ary QAM modulators so that one can map input data into symbols. Then after that, symbols pass to IFFT block to generate N- parallel data streams, since OFDM transmits data streams in parallel simultaneously over the subcarriers. If we are having following series of data

$$X[n], n = 0 \text{ to } N - 1 \quad (3.1)$$

We define the FFT of  $x[n]$  i.e., the output of frequency domain as

$$X[k] = \sum_{n=0}^{N-1} x(n) e^{-j\pi 2kn/N}, k = 0 \text{ to } N - 1 \quad (3.2)$$

$X[k]$  is the component of the spectrum due to the frequency.

$$F = kFs / N \quad (3.3)$$

The transformed output is added with cyclic prefix to decrease ISI effects of channel. It is usually 25% of the last part of the original transformed signal. In the receiver, the overturn process is performed by deleting the cyclic prefix, FFT modulation and demodulation to get back the real data [26].

The IFFT i.e., the output in discrete domain as

$$x[n] = \frac{1}{N} \sum_{k=0}^{N-1} x(n) e^{\frac{j\pi 2kn}{N}}, n = 0 \text{ to } N - 1 \quad (3.4)$$

IDFT/DFT is used in conventional OFDM but in wavelet based OFDM, IDWT is used rather than of IDFT and DWT rather than of DFT. In OFDM which is wavelet based, cyclic prefix are not required [36].

### 3.1.2 Filter Splitting

A little portion of a continuous signal is called a wavelet. In Discrete wavelet, the samples are discretely sampled and the more significant fact is that it gives information regarding both time and frequency. Various kinds of wavelet transforms are Haar, Daubechies, Biorthogonal, etc. Orthonormal basis property and the perfect reconstruction property should be satisfied by the wavelet Transform. It divides the given signal into smaller wavelets through wavelet function and the basis function. The Discrete Wavelet Transform consists of both low pass and high pass filters which actually acts as the Quadrature Mirror Filters (QMF). Approximated coefficients are given by the low pass filter and detailed coefficients are provided by the high pass filter. Initially, input is gone across the low pass filter  $g(n)$  and output is called the approximated coefficient and then it is gone through the high pass filter  $h(n)$  which gives the output called as the detailed coefficient. By this way, wavelet decomposes the signal.

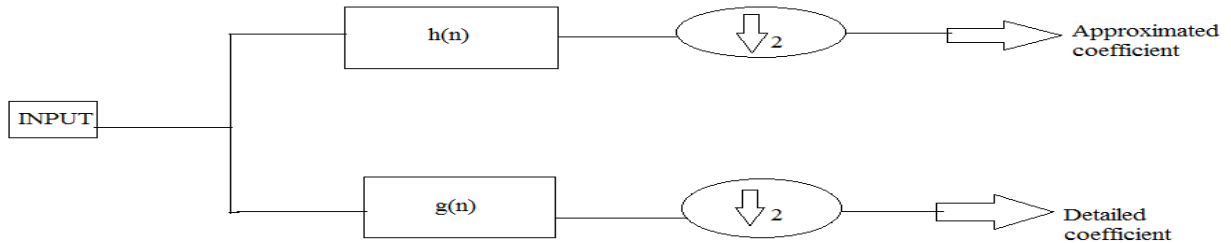

Figure 3.1 Filter splitting [34]

The mathematical expression is given by the following equations which are defined below:

$$F1(k) = \sum_{n=0}^{\infty} x[n] g[2k - n] \quad (3.5)$$

$$F1(k) = \sum_{n=0}^{\infty} x[n] h[2k - n] \quad (3.6)$$

The DWT-OFDM has a very great advantage over the FFT-OFDM [37].

### 3.2 GFDM

It is a block based transmission which is non-orthogonal model and having K subcarriers which has M sub symbols for every block. The overall count of symbols becomes KM.

#### 3.2.1 GFDM Model

Take a WGFDM modulator having K number of subcarriers, M sub symbols. In P-QAM mapper, the input is having binary bits that are firstly fed which gives a data of KM length. Every of these symbols of information which are represent by points of constellation which are complex, are crossed across the modulator. In this modulator, according to the block frame structure, firstly the symbols are converted from serial to parallel [17].

Nextly, every symbol of data is up converted by K samples and received throughout a waveform given by,

The equation for GFDM:

$$g_{k,m}(n) = g[(n - mk) \bmod KM] e^{\frac{j\pi 2kn}{k}} \quad (3.7)$$

The equation for MGFDM:

$$g_{k,m}(n) = g(n) e^{\frac{j\pi 2kn}{k}} \quad (3.8)$$

Here, filter which is used for the shaping of pulse ,in that the modulo operation tells about circular shift operation. In this, for pulse shaping the samples in the GFDM system ,we have taken root raised cosine filter and in in the WMGFDM system, DPSSs are used for pulse shaping The addition of all the WMGFDM signals which are modulated are given as:

$$x(n) = \sum_{k=0}^{K-1} d_k(m) \sum_{m=0}^{M-1} g_{k,m}(n) \quad (3.9)$$

The model of given matrix for the WMGFDM signal that is modulated is expressed as:

$$X = Ad \quad (3.10)$$

Here, transmitter modulated matrix is represented by A and expressed as [34]

$$A = [G E_1 G \dots E_{K-1} G] \quad (3.11)$$

With  $G$  a  $KM \times M$  filter matrix having length of  $KM$

$$g = [g_0 \dots g_{KM-1}]^T \quad (3.12)$$

The idea of wavelet is taken in order to get good localization of time-frequency and in addition, it provides more elasticity in the design of pulse shaping filter. It assures that the considered pulse has flat derivative to lock up the span of frequency as much. Lot of authors has presented various methods on the wavelets concept [24, 25].

An oscillation which is like a wave that's amplitude starts at zero, keep incrementing, and then comes to zero is called a wavelet. To guarantee this flat transition, Meyer introduces an auxiliary function which used as an inner argument of various filter in which pulse is shaping [26]. The Meyer auxiliary function is expresses as

$$V(x) = x^4(35 - 84x + 70x^2 - 20x^3) \quad (3.13)$$

Therefore, we will think about the effect of improved filters which are pulse shaping with and without Meyer auxiliary function on the GFDM efficiency.

These pulse shaping filters are root raised cosine and raised cosine functions in the domain of time. Here, we have taken the expression in the time-domain which is the output by exchanging the independent frequency variable and time variable to each other.

$$g_{RC}(t) = \begin{cases} 1, & |t| \leq \frac{(1-\alpha)T}{2} \\ \frac{1[1+\cos(\pi P_{RC}(t))]}{2}, & \frac{(1-\alpha)T}{2} < |t| \leq \frac{(1+\alpha)T}{2} \\ 0, & otherwise \end{cases} \quad (3.14)$$

Where  $P_{RC}$  is the inner argument of the cosine written as

$$P_{RC} = \frac{(|t| - \frac{(1-\alpha)T}{2})}{\alpha T} \quad (3.15)$$

By defining the Meyer auxiliary function  $v(x)$ , the cosine inner argument is changed as

$$P_{RC} = \frac{v(|t| - \frac{(1-\alpha)T}{2})}{\alpha T} \quad (3.16)$$

The RRC filter is written as

$$g_{RRC}(t) = \sqrt{g_{RC}(t)} \quad (3.17)$$

Where RC is raised cosine filter and RRC is root raised cosine filter [34].

### 3.2.2 WM-GFDM Model

In WM-GFDM, the intricate exponentials of traditional GFDM are substituted by wavelets at different scales  $j$  and  $k$  time locations. Note that for the regular GFDM demonstrate utilizing the IFFT square,  $W$  can be communicated in an unexpected way. The broadened matrix  $E$  of size  $KM \times M$  is given by a  $M$  times redundancy of the identity matrix  $IK \times K$ ,

$$E = [I_{K \times K1} \dots I_{K \times Kk}]^T \quad (3.18)$$

$$X = Ad \quad (3.19)$$

Where  $A$  is a transmitter matrix having dimensions  $KM \times KM$  [38].

Let us express  $W_{TX} = W_E^T$ . Only the elements present diagonally are sent, the symbols present are expressed by the matrix of data and the column is written as,

$$x(n) = g_{Tx,n} D w_{Tx,n} \quad (3.20)$$

Where  $g$  represents pulse shaping filter and  $D$  is incoming data [39].

### 3.2.3 Wavelets Construction

Theory of Wavelet gives many filters which are orthogonal having best time and frequency properties. In this, we will study Haar wavelet. The vanishing order of haar wavelet is [39].

The Haar transform has the following properties.

- There is no need for multiplications. Only additions are required and there are many elements having zero value in the Haar matrix, so there is short computation time. It is faster as compared to Walsh transform, whose matrix consists of  $+1$  and  $-1$ .
- The length of Input and output length are the same. However, the length should be a power of 2.
- It can be used to detect feature of signals which are localized. Due to the orthogonal property of the Haar function, the frequency components of input signal can be easily analyzed.

Haar wavelet transform matrix is written as

$$W_{Haar} = \begin{bmatrix} W_{K/2 \times K/2} \otimes [1,1] \\ I_{K/2 \times K/2} \otimes [1,1] \end{bmatrix} \quad (3.21)$$

$$W_{2 \times 2} = \frac{1}{\sqrt{2}} \begin{bmatrix} 1 & 1 \\ 1 & -1 \end{bmatrix} \quad (3.22)$$

The wavelet functions choice depends on its applications. Haar wavelet is the basic, simplest and oldest orthonormal wavelet. In this energy of signal is conserved and it is very efficient wavelet in terms of memory [39].

### 3.2.4 Analysis of PAPR

For the most part the disadvantages of any multicarrier procedure are its high PAPR. PAPR is the proportion of peak power to mean power of the GFDM symbol. Numerically it can be communicated as,

$$PAPR = \frac{\max\{|x(n)|^2\}}{E\{|x(n)|^2\}} \quad (3.23)$$

Where  $E\{.\}$  defines the ensemble average figured over the GFDM symbol. The introduction of the proposed system is estimated by CCDF of the PAPR, which gives the likelihood that the PAPR of an information block surpasses a given threshold ( $PAPR_0$ ) and is composed as takes after,

$$CCDF(PAPR_0) = Pr \{PAPR > PAPR_0\} \quad (3.24)$$

Simulations were directed to confirm the PAPR execution of the proposed WM-GFDM model [38].

## CHAPTER 4

### RESULTS AND DISCUSSIONS

OFDM model of Wireless Communication is implemented and various modulation schemes are used which are BPSK, QAM, QPSK etc. The various performance parameters evaluated are BER, SNR etc. This is intended to study and analyze the performance of OFDM technique under various modulation schemes. The MATLAB software which is used for the implementation of this research work includes a wide range of functions to study, analyze and simulate the different kinds of communications system. The OFDM system is simulated to get the performance of different modulation techniques. The BER v/s SNR plot for different modulation techniques reveals that for higher order modulation schemes the BER increases with increasing SNR. Then again, the modulation schemes which are having lower order (BPSK and QPSK) encounter less BER. In this way, it gives better results as in terms of BER and SNR.

We additionally complete a correlation of ordinary GFDM utilizing the Root Raised Cosine channel (RRC) with roll off factor  $\alpha = 0.5$  and  $\alpha = 1$ , with the proposed WM-GFDM.

Clearly, WGFDM beats traditional GFDM for both roll off factor values utilized. It is likewise important to take note of that as the move off factor is expanded from 0.5 to 0.9, the PAPR performance turns out to be more regrettable.

The CCDF of the PAPR for the proposed Haar wavelet based WM-GFDM is appeared .From the figure we can deduce that there is a noteworthy change in PAPR decrease when we utilized the proposed wavelets.

As specified previously, OFDM is an uncommon instance of GFDM having number of sub carriers,  $M = 1$  and a model channel is rectangular channel. GFDM is a non-symmetrical multicarrier procedure brings about natural ISI/ICI which will influence the SER execution when contrasted with an OFDM framework and is portrayed in the figure. In GFDM, a cyclic prefix (CP) which is single is embedded after the whole block, comprising of various subcarriers and numerous sub symbols, though if there should arise an occurrence of OFDM, CP is embedded for each transmitted symbol. These outcomes in increment in the spectral efficiency of the framework. Additionally, in WM-GFDM, no CP is required, which likewise will additionally increment efficiency of the spectrum.

Table 4.1 Parameters for transmitter

Subcarriers used, K	64
Sub symbols used, M	8, 1(OFDM)
Length of Cyclic Prefix	16
Method of Pulse Shaping	Rectangular (OFDM), RRC (GFDM), DPSS (WM-GFDM)
Spectral Estimation Method	Pwelch

In OFDM, as number of sub symbols increases in case of QAM, bit error rate is improved.

#### 4.1 ALGORITHM FOR CALCULATING BIT ERROR RATE

Step 1. Define number of data subcarriers, number of symbols, fft size, bit to noise ratio.

Step 2. Random 1's and 0's are generated.

Step 3. Modulation depending on number of subsymbols.

Step 4. Taking FFT.

Step 5. Appending cyclic prefix.

Step 6. Add Gaussian noise of unit variance and zero mean.

Step 7. In receiver, removing cyclic prefix.

Step 8. Converting data to frequency domain.

Step 9. Demodulation is done.

Step 10. Counting the errors.

Step 11. Plot it.

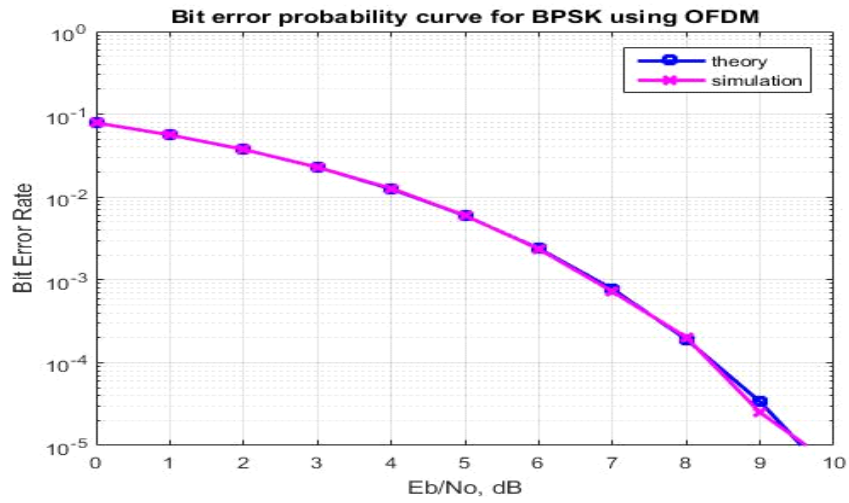

Figure 6.1 BER of OFDM using BPSK

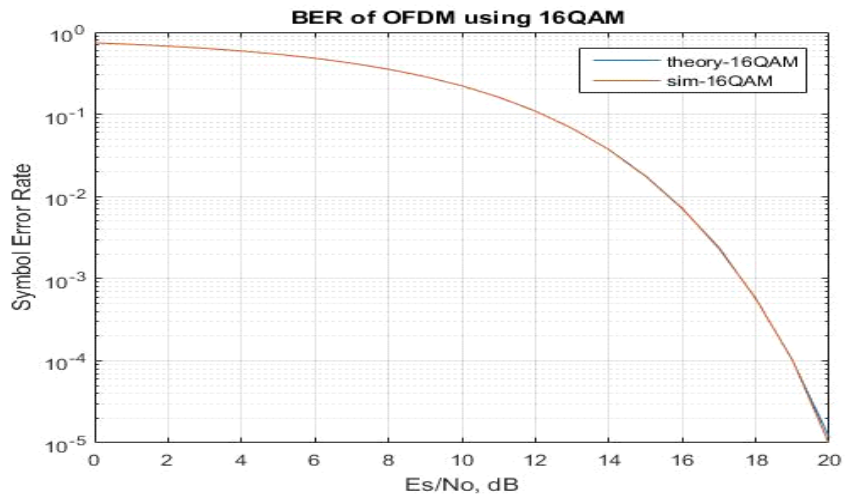

Figure 6.2 BER of OFDM using 16 QAM

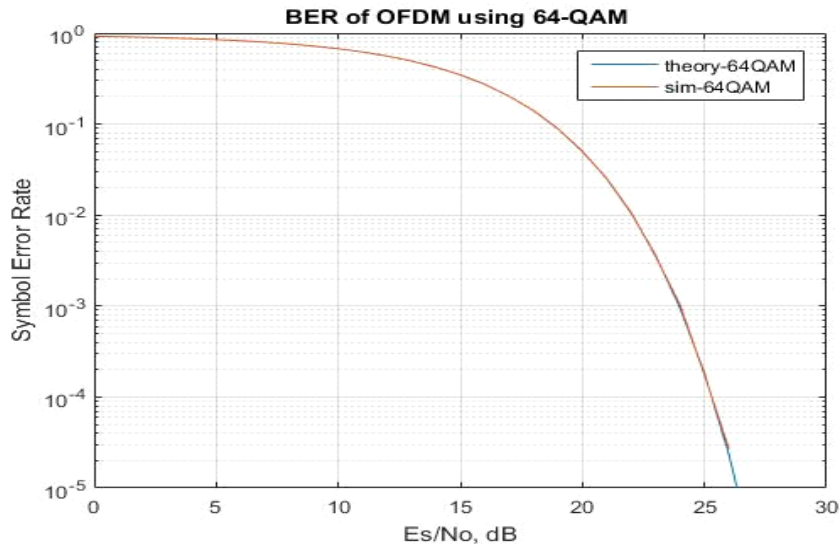

Figure 6.3 BER of OFDM using 64 QAM

In OFDM, as number of sub symbols increases in case of QAM, bit error rate is improved.

#### 4.2 ALGORITHM FOR CALCULATING PEAK TO AVERAGE POWER RATIO

Step 1. Define number of data subcarriers, number of symbols, fft size, bit to noise ratio.

Step 2. Random 1's and 0's are generated.

Step 3. Modulation depending on number of subsymbols.

Step 4. Taking FFT.

Step 5. Use root raised cosine for filtering.

Step 5. Shift subcarriers.

Step 6. Appending cyclic prefix.

Step 7. Computing the peak to average power ratio for each symbol.

Step 8. Plot it.

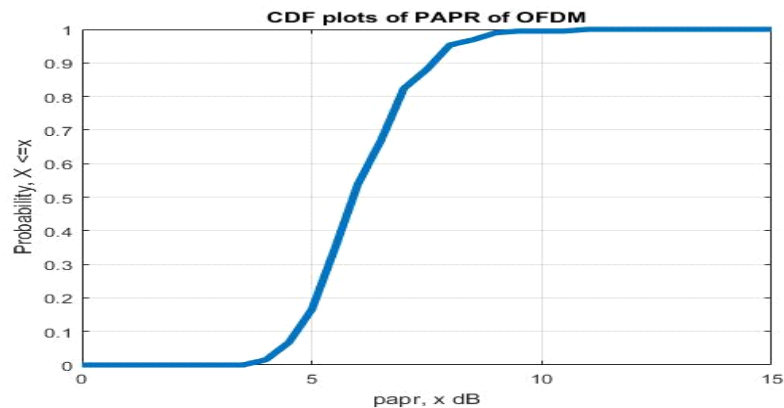

Figure 6.4 CDF plot of OFDM

### 4.3 ALGORITHM FOR CALCULATING PEAK TO AVERAGE POWER RATIO OF GFDM

- Step 1. Define number of data subcarriers, number of symbols, bit to noise ratio.
- Step 2. Random 1's and 0's are generated.
- Step 3. Modulation depending on number of subsymbols.
- Step 4. Taking FFT..
- Step 5. Shift subcarriers.
- Step 6. Appending cyclic prefix.
- Step 7. Computing the peak to average power ratio for each symbol.
- Step 8. Plot it.

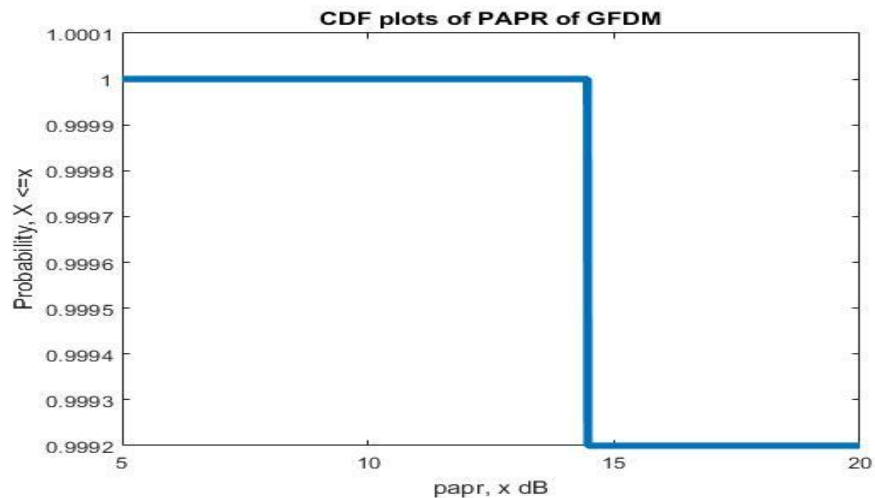

Figure 6.5 CDF plot of GFDM with RRC filter

### 4.4 ALGORITHM FOR CALCULATING PEAK TO AVERAGE POWER RATIO

- Step 1. Define number of data subcarriers, number of symbols, fft size, bit to noise ratio.
- Step 2. Random 1's and 0's are generated.
- Step 3. Modulation depending on number of sub symbols.
- Step 4. Taking DWT.
- Step 5. Use dpss for filtering.
- Step 6. Shift subcarriers.
- Step 7. Appending cyclic prefix.
- Step 8. Computing the peak to average power ratio for each symbol and plot it.

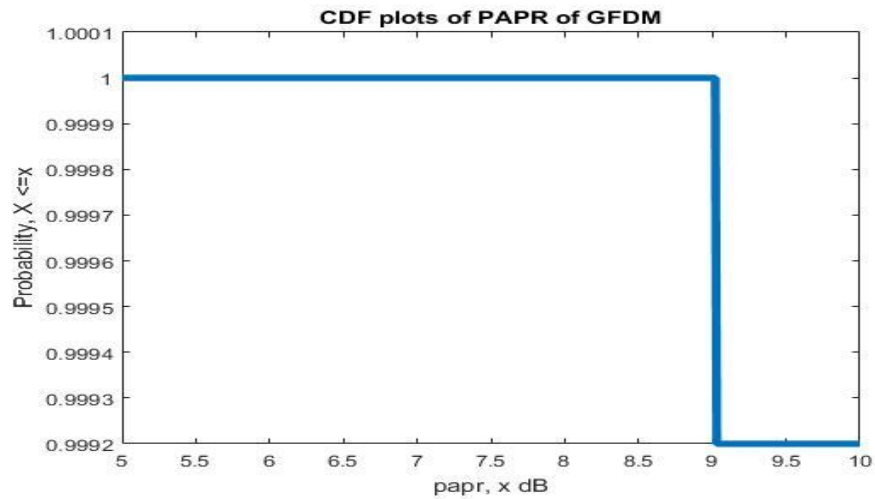

Figure 6.6 CDF plot of GFDM with wavelet transform

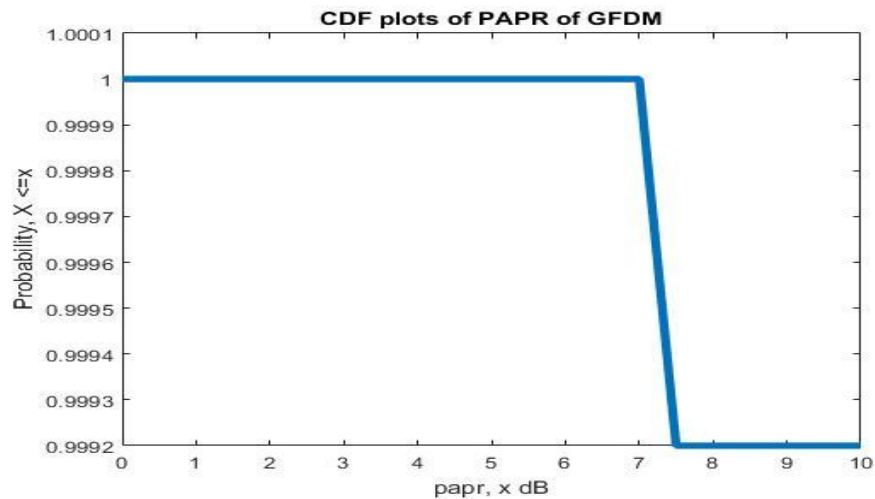

Figure 6.7 CDF plot of GFDM with Meyer RRC filter

#### 4.5 ALGORITHM FOR CALCULATING GFDM SPECTRUM

- Step 1. Define. number of subcarrier, subsymbol, cyclic prefix, roll off factor.
- Step 2. Random 1's and 0's are generated.
- Step 3. Split into real and imaginary parts.
- Step 4. RRC filtering is done.
- Step 5. Frequency shift oqam.
- Step 6. Form  $A_i$  matrix and  $A_q$  matrix.
- Step 7. Multiply data with filter.

- Step 8. Appending cyclic prefix.
- Step 9. Calculate power spectral density.
- Step 10. Plot it.

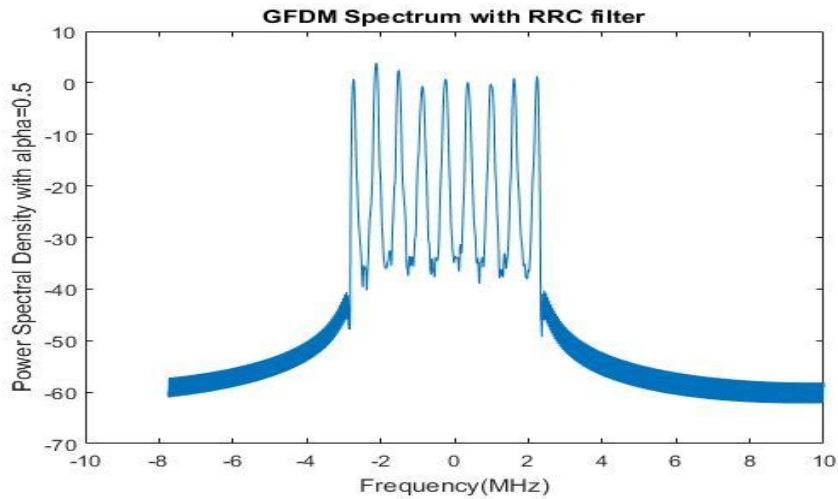

Figure 6.8 GFDM spectrum using RRC Filter

#### 4.6 ALGORITHM FOR CALCULATING GFDM SPECTRUM

- Step 1. Define. number of subcarrier, subsymbol, cyclic prefix, roll off factor.
- Step 2. Random 1's and 0's are generated.
- Step 3. Split into real and imaginary parts.
- Step 4. Meyer auxiliary equations used and filtering is done.
- Step 5. Frequency shift oqam.
- Step 6. Form  $A_i$  matrix and  $A_q$  matrix.
- Step 7. Multiply data with filter.
- Step 8. Appending cyclic prefix.
- Step 9. Calculate power spectral density.
- Step 10. Plot it.

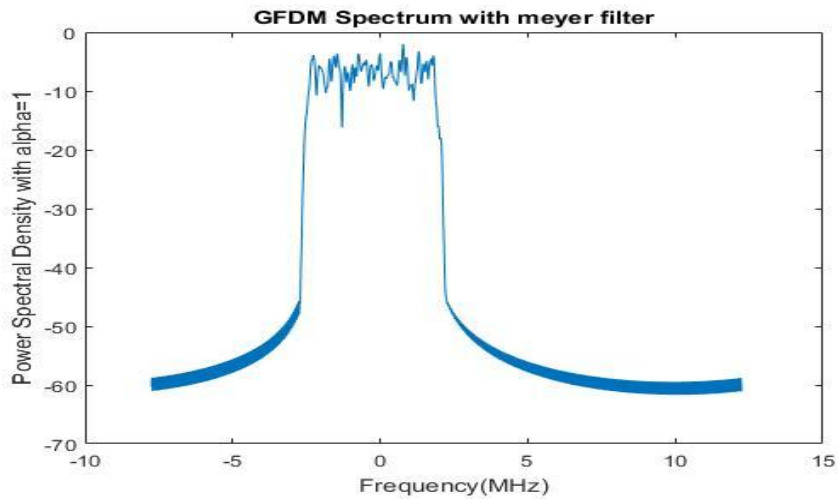

Figure 6.9 GFDm spectrum using meyer filter with roll off factor=1

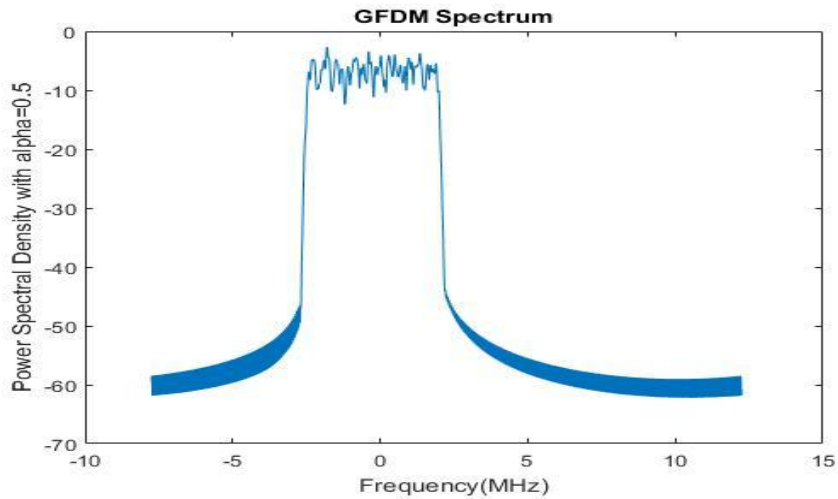

Figure 6.10 GFDm spectrum using meyer filter with roll off factor=0.5

#### 4.7 ALGORITHM FOR CALCULATING OFDM SPECTRUM

- Step 1. Define number of data subcarriers, number of symbols, fft size, bit to noise ratio.
- Step 2. Random 1's and 0's are generated.
- Step 3. Modulation depending on number of sub symbols.
- Step 4. Taking FFT.
- Step 5. Appending cyclic prefix.
- Step 6. Calculate power spectral density.
- Step 7. Plot it.

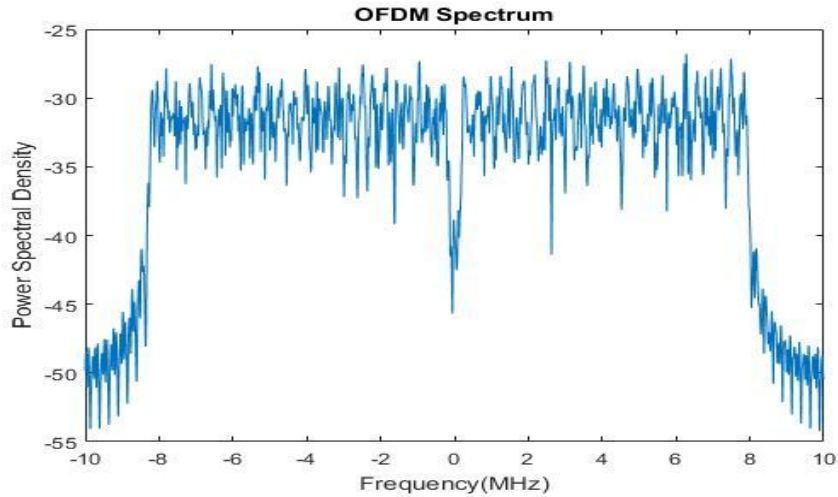

Figure 6.11 OFDM Spectrum

GFDM flexibility provides advantage over out-of-band emission. In this section we will discuss about the power spectral density v/s frequency graph. We exhibited the OOB emission of OFDM and GFDM, at the transmit side. For our setup, OFDM and GFDM show indistinguishable OOB discharge performance. GFDM gives good OOB emission over OFDM, which is because of the way that the number of subcarriers for the two waveforms was not equivalent. It can be evidently seen that the power consumes on the side lobes is much higher in case of OFDM but more power is consumed in case of GFDM on the main lobes. When it comes to complexity comparison, GFDM is more complex as compared to OFDM, the difference is more prominent in case of GFDM because we use a root-raised cosine filter and in OFDM rectangular pulse shaping filter is used.

## CHAPTER 5

### CONCLUDING REMARK, FUTURE SCOPE AND APPLICATIONS

- GFDM is a non-orthogonal multicarrier procedure which produces natural ISI/ICI that will influence the SER performance when contrasted with an OFDM framework. In GFDM a single cyclic prefix (CP) is embedded in the entire block, comprising of various subcarriers and numerous sub channels, though a CP for OFDM is embedded for each transmitted symbol. This will expand the productivity and efficiency of the framework. In addition, in WM-GFDM, no CP is required, which likewise will additionally increment spectral efficiency. In OFDM, QAM is most efficient as compared to other modulation schemes, as number of sub symbols increases in case of QAM, bit error rate is improved.
- GFDM is better technique because it has low PAPR, which helps in low power consumption of mobile devices.
- Power spectral density (PSD) of GFDM is less this shows GFDM provides lesser leakage of energy on the side lobes which helps in reduction of OOB radiation. But for one reason GFDM is not suitable for 5G technology i.e. its complexity. It is more complex as compared to OFDM. This makes the system cheaper.
- A primer examination of actualizing wavelet changes with regards to MGFDM is done by utilizing the Haar wavelet.
- WGFDM configuration model is a good possibility for future needs of wireless communication. There is still a great deal of work to be finished exploring the most regularly utilized methods to additionally decrease the PAPR. Meyer wavelet has overall better spectral efficiency and low PAPR as compared to other techniques.

## 5.1 APPLICATIONS OF 5G TECHNOLOGIES

The 5G technology has variety of applications. 4G applications is available across various wireless technologies like LTE, Wi-Fi, etc. and also in devices like cell phones, laptop spreaders, digital cameras and printers. 4G applications are extended versions of the existing 3G services, but it is still unclear ,will the capacity of 4G will hold for the mobile world. Some of the applications of 5G networks are:

- Education: For individuals who are occupied with deep rooted instruction, 5G gives a decent opportunity. Individuals anyplace on the planet can do their education in a practical way through on the web.
- Crisis management: There is breakdown in communication systems due to Natural disasters. To restore the system, it might take days or weeks. But in case of 5G it is easy to get back from such issues very swiftly.
- Virtual Presence: 5G gives services to the user at all times.
- Virtual Navigation: 5G gives virtual navigation facility to the users through which one can get a database of various cities and the streets.
- Security: 5G network architecture provides us various security features like authentication, authorization, and encryption.
- Tele-Medicine: Remote health monitoring is provided by 5G, people need not to visit hospital they can get treatment through video conferencing.
- Applications in Tele-geo processing: It is the integration of Geographical Information System and Global Positioning System by which a person can access the locations.
- Artificial Intelligence: Artificial sensors help in communicating with mobile phones.
- Travelling: With the launch of latest apps in phones, people can share their live information while they are travelling to any place.
- Use of Bluetooth and NFC innovation incorporated advanced mobile phones in the traveler travel process.
- Economic development: Economic development is enhanced by 5G because this technology provides consumers and businesses high-value wireless data and content services [40].

## ***REFERENCES***

- [1] L Xu *et al.* (2017). Performance analysis of relaying mobile d2d cooperative networks, *J Franklin Instrumentation*, 354(2), pp.902–916.
- [2] Khan Manjurul H. and Barman P.C (2015). 5G- future generation technologies of wireless communication, revolution 2020, *American Journal of Engineering Research (AJER)* Volume-4, Issue-5, pp-206-215.
- [3] Kumar Dass Deepak and Kumar Parvind (2017). Modern Wireless 5G Technology: Future of Super Fast Internet, *IJESC*.
- [4] Bahai AR, Saltzberg BR and Ergen M. (2004). Multi-carrier digital communications: theory and applications of OFDM, *Springer Science & Business Media*.
- [5] Kumar Arun and Gupta Manisha (2017). A review on activities of fifth generation mobile communication system ,*Alexandria Engineering Journal* .
- [6] Vakilian V *et al.* (2013). Universal-filtered multicarrier technique for wireless systems beyond LTE, *IEEE globe communication workshops*, pp. 223–228.
- [7] Schmidl TM and Cox DC. (1997). Robust frequency and timing synchronization for of” OFDM, *IEEE Transaction Communication*;45(12),pp.1613–1621.
- [8] Fettweis G, Krondorf M and Bittner S. (2009). GFDM-generalized frequency division Multiplexing *Vehicular technology conference Spring 69th. IEEE*, pp. 1–4.
- [9] K Abdullah and ZM Hussain (2007). Performance of fourier-based and wavelet-based ofdm for dvb-t systems, *IEEE Telecommunication networks and applications conference*, pp. 475–479.
- [10] AH Kattoush (2010). A novel radon-wavelet based ofdm system design and performance under different channel conditions, *International Arab J Information Technology*,7(4),pp.419–427.

- [11] Sandberg SD and Tzannes MA (1995). Overlapped discrete multitone modulation for high speed copper wire communications, *IEEE Areas Communication*,13 (9),pp.1571–1585.
- [12] Slepian D (1965). Some asymptotic expansions for prolate spheroidal wave functions, *J Math Physics*, 44(1), pp.99–140.
- [13] Slepian D (1968). A numerical method for determining the eigen values and eigen functions of analytic kernels, *SIAM J Numerical Analysis* ,5(3),pp.586–600.
- [14] Daoud O, Hamarshah QJ and Saraireh S (2014). Papr reduction based on entropy wavelet transform for sniffer mobile robot, *AEU-International Journal of Electronics and Communication* ,68 (12),pp.1165–1172.
- [15] Chafii M, Harbi YJ, Burr AG. (2016). Wavelet-ofdm vs. ofdm: performance comparison. In: *Telecommunications (ICT), 23rd international conference*, pp. 1–5.
- [16] Abdullah K, Hussain ZM. (2007). Performance of fourier-based and wavelet-based ofdm for dvb-t systems. In: *Telecommunication networks and applications conference, Australasian*. IEEE pp. 475–9.
- [17] Kumar Atul and Maurizio Magarini (2016). Improved Nyquist Pulse Shaping Filters for Generalized Frequency Division Multiplexing, *Conference Paper*, DOI: 10.1109/LATINCOM.2016.7811588.
- [18] Kumar Pavan and Kumari Amita (2016). BER Analysis Of BPSK, QPSK, 16-QAM & 64-QAM Based OFDM System Over Rayleigh Fading Channel, *IOSR Journal of Electronics and Communication Engineering(IOSR-JECE)*,Volume 11, Issue 4, pp. 66-74.
- [19] Muhammad Sameen, Khan Inam Ullah and Azim Nazia (2016). Comparison of GFDM and OFDM with respect of SER, PSD and PAPR, *IJMCA*, Volume 4, Number 6.
- [20] Antapurkar Shwetal K. , Pandey Avinash and Gupta K.K. (2015). GFDM Performance in terms of BER, PAPR and OOB and comparison to OFDM system, *Conference Paper in AIP Conference Proceedings*, DOI: 10.1063/1.4942721.

- [21] Enver Hamiti and Fatlum Sallahu (2015). Spectrum Comparison between GFDM, OFDM and GFDM Behavior in a Noise and Fading Channel, *International Journal of Electrical and Computer Engineering Systems*, Volume 6, Number 2.
- [22] Rohit Datta *et al.* (2012). Generalized frequency division multiplexing in cognitive radio, *20th European Signal Processing Conference (EUSIPCO 2012)* Bucharest, Romania.
- [23] Fettweis GP (2014). The tactile internet: applications and challenges, *IEEE Vehicular Technology Magazine*,9(1),pp.64–70.
- [24] N. Michailow *et al.* (2012). Bit Error Rate Performance of Generalized Frequency Division Multiplexing, in *IEEE Vehicular Technology Conference*.
- [25] C. H. Hwang, G. L. Lai, and S. C. Chen (2010). Spectrum Sensing in Wideband OFDM Cognitive Radios, *IEEE Transactions on Signal Processing*, Volume 58, Number 2, pp. 709 – 719.
- [26] Yucek and H. Arslan (2009). A Survey of Spectrum Sensing Algorithms for Cognitive Radio Applications, *IEEE Communications Surveys & Tutorials*, Volume 11, Number 1, pp. 116–130.
- [27] Michailow N. *et al.* (2011). Integration of a GFDM Secondary System in an OFDM Primary System, in *Future Network Summit*.
- [28] Datta Rohit *et al.* (2012). Generalized frequency division multiplexing in cognitive radio, *20th European Signal Processing Conference (EUSIPCO 2012)* Bucharest, Romania.
- [29] Michailow N *et al.* (2014). Generalized frequency division multiplexing for 5th generation cellular networks, *IEEE Transaction Communication*, 62(9),pp.3045–3061.
- [30] G. Fettweis and S. Alamouti (2014). 5G: Personal Mobile Internet Beyond What Cellular Did to Telephony, *IEEE Communications Magazine*, volume 52, number 2, pp. 140–145.
- [31] G. Wunder *et al.* (2014). 5GNOW: Non-Orthogonal, Asynchronous Waveforms for Future Mobile Applications, *IEEE Communications Magazine*, Volume 52, Number 2, pp. 97–105.

- [32] J. Bingham (1990). Multicarrier Modulation for Data Transmission: An Idea Whose Time Has Come, *IEEE Communications Magazine*, Volume 28, Number 5, pp. 5–14.
- [33] V. Vakilian *et al.* (2013). Universal-Filtered Multi-Carrier Technique for Wireless Systems Beyond LTE, in *9th International Workshop on Broadband Wireless Access (BWA'13) co-located with IEEE Globecom'13*, Atlanta, GA, USA.
- [34] Kattoush AH (2010). A novel radon-wavelet based ofdm system design and performance under different channel conditions, *International Arab J Information Technology*,7(4),pp.419–427.
- [35] Abdullah K and Hussain Z.M (2009). Studies on DWT-OFDM and FFT-OFDM systems, *International Conference on Communication, Computer and Power (ICCCP 2009)*, pp. 15-18.
- [36] Chafii M, Harbi YJ and Burr AG (2016). Wavelet-ofdm vs. ofdm: performance comparison, *IEEE 23rd International Conference Telecommunications (ICT)*, pp. 1–5.
- [37] Pasi Vishal, Nigam Prateek and Chaurasia Vijayshri (2013). Review on OFDM a Brief Survey, *International Journal of Scientific and Research Publications*, Volume 3, Issue 11, ISSN 2250-3153.
- [38] Kumar Bandari Shravan, Vakamulla Venkata Mani and Drosopoulos Anastasios (2017). PAPR analysis of wavelet based multitaper GFDM system, *International Journal Electronics Communication (AEÜ)* 76 ,pp.166–174.
- [39] Vidakovic B (2009). Statistical modeling by wavelets, *John Wiley & Sons*, Volume 503.
- [40] Khan Manjurul H. and Barman P.C (2015). 5G- future generation technologies of wireless communication, revolution 2020, *American Journal of Engineering Research* Volume-4, Issue-5, pp-206-215.