

**IMPACT OF IMPULSE NOISE ON THE SYMBOL ERROR  
RATE PERFORMANCE OF OFDM SYSTEMS**

Thesis submitted in the partial fulfillment of requirement for the award of degree  
of

**MASTER OF ENGINEERING  
IN  
ELECTRONICS AND COMMUNICATION ENGINEERING**

Submitted by

**Ambika Bawa**

**Roll No. 801061003**

Under guidance of

**Dr. Amit Kumar Kohli**

**Assistant Professor, ECED**

**T.U. Patiala**



**ELECTRONICS AND COMMUNICATION ENGINEERING DEPARTMENT**

**THAPAR UNIVERSITY**

**(Established under the section 3 of UGC Act, 1956)**

**PATIALA – 147004, INDIA**

**JUNE-2012**

## DECLARATION

I hereby declare that the work, which is being presented in this thesis, entitled “**Impact of Impulse Noise on the Symbol Error Rate Performance of OFDM Systems**”, by me in partial fulfillment of the requirements for the award of degree of Master of Engineering in Electronics and Communication Engineering at Electronics and Communication Engineering department of Thapar University, Patiala, is an authentic record of my own work carried out under the supervision of **Dr. Amit Kumar Kohli**

The matter presented in this thesis has not been submitted in any other University / Institute for the award of any other degree.

Date: 18/6/2012

  
Ambika Bawa

Roll no. 801061003

This is to certify that the above statement made by the student is correct to the best of my knowledge and belief.

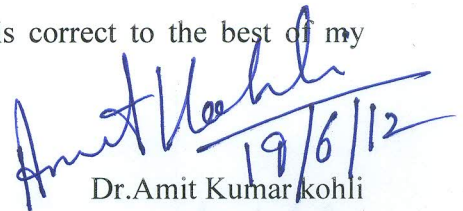
  
Dr. Amit Kumar kohli

Assistant Professor

Electronics and Communication Department

Thapar University

Patiala-147004

Countersigned by

  
Dr. Rajesh Khanna

Professor and Head, ECED

Thapar University, Patiala

Date:

  
Dr. S.K. Mohapatra

Dean of Academic Affairs

Thapar University, Patiala

Date:

## **ACKNOWLEDGEMENT**

I would like to express my gratitude to **Dr. Amit Kumar Kohli**, Assistant professor, Electronics and Communication Engineering Department, Thapar University, Patiala for his patient guidance and support throughout this thesis work. I am truly very fortunate to have the opportunity to work with him. He has provided me help in technical writing and presentation style, and I found this guidance to be extremely valuable.

I am also thankful to entire faculty and staff members of Electronics and Communication Engineering Department for their unyielding encouragement.

I am greatly indebted to all my friends, who have graciously applied themselves to the task of helping me with ample morale support and valuable suggestions. Finally, I would like to extend my gratitude to all those persons who directly or indirectly helped me in the process and contributed towards this work.

Finally, I would like to extend my gratitude to all those persons who directly or indirectly helped me in the process and contributed towards this phase of my thesis work.

**Ambika bawa**

**(801061003)**

## **ABSTRACT**

**Impulsive noise and Multipath effects are the main reasons to cause bit error in the power line communication and broadband wireless communication over fading channels. In this thesis report, the symbol error rate (SER) performance of the orthogonal frequency division multiplexing (OFDM) system under the impulsive noise and multipath effects are analyzed theoretically and by simulations in terms of closed form formulas. Through the analysis, it is shown that OFDM can mitigate the adverse effect of the impulsive noise, and only the heavily disturbed impulsive noise will interfere the SER performance of the OFDM systems. It is also shown that the adverse effect of multipath is more serious than that of impulsive noise. In this thesis report, the guard interval is used to improve the SER performance of the OFDM system. As the longer guard interval is inefficient in using the signal power, the optimum guard interval that can achieve the best SER performance is studied.**

**Under additive impulsive noise, the fast Fourier transform (FFT) in the OFDM receiver introduces changes in the subcarrier noise statistics. As a result, the complexity of optimal detection becomes exponential in the number of subcarriers. Many previous approaches assume a statistical model of the impulsive noise and use parametric methods in the receiver to mitigate impulsive noise. Parametric methods degrade with increasing model mismatch, and require training and parameter estimation. Therefore, my thesis work concludes the study of noise bucket effect on the performance of OFDM systems.**

**Simulation results are presented to demonstrate the statistical properties of impulse noise on 4G mobile communication systems using OFDM technology working under wireless fading channel. The noise bucket effect may be justified by Gaussian distribution due to DFT operator at the receiver. It may be inferred from the presented results that the effects of impulse noise are quite similar to the additive white Gaussian noise on the SER perforation of OFDM systems in the statistical sense.**

**Keywords: OFDM, Impulse Noise, Noise Bucket effect, Multicarrier Communication, DFT, IDFT.**

# TABLE OF CONTENT

DECLARATION	i
ACKNOWLEDGEMENT	ii
ABSTRACT	iii
LIST OF ABBREVIATION	viii
LIST OF FIGURES	x
CHAPTER 1	1-13
INTRODUCTION	1
1.1 Overview of OFDM	1
1.2 Generation of OFDM symbols	2
1.3 Intersymbol and Intercarrier interference	4
1.4 Orthogonal frequency-division multiplexing	6
1.5 Characteristics and principles of operation	6
1.5.1 Orthogonality	6
1.5.2 Serial to parallel conversion	8
1.5.3 Modulation of data	8
1.5.4 Inverse Fourier transform	9
1.5.5 Guard period	9
1.5.6 Channel	9
1.5.7 Receiver	9
1.5.8 Implementation using the FFT algorithm	10

1.5.9	Guard interval for elimination of inter-symbol interference	10
1.5.10	Channel coding and interleaving	12
1.6	Problem statement	13
1.7	Organization of thesis	13
<b>CHAPTER 2</b>		<b>14-32</b>
	<b>LITERATURE SURVEY</b>	<b>14</b>
2.1	Noise bucket effect for impulse noise in OFDM	14
2.1.1	Impulse noise and its effects in OFDM:	15
2.2	Impulse noise cancellation in the system with OFDM modulation	15
2.3	Analysis of OFDM receiver with blanking nonlinearity in impulsive noise environment	16
2.4	Impulsive noise cancellation in systems with OFDM modulation	18
2.5	Analysis of simple impulsive noise mitigation schemes for OFDM receiver and its system model	23
2.6	Impulsive noise cancellation in multicarrier transmission	26
2.7	Bit-interleaved coded OFDM with iterative decoding in impulsive noise	28
2.7.1	System model	31
<b>CHAPTER 3</b>		<b>33-47</b>
	<b>BASIC OFDM SYSTEM MODEL FOR COMMUNICATION</b>	<b>33</b>
3.1	Understanding an OFDM transmission	33
3.1.1	OFDM system	34
3.2	Cyclic prefix in orthogonal frequency division multiplexing	35

3.2.1	Signal model and interference calculation	36
3.3	BPSK BER with OFDM modulation	37
3.3.1	Model description	38
3.3.2	Results and discussions	39
3.4	BER for BPSK in OFDM with Rayleigh multipath channel	41
3.4.1	Overview of MIMO-OFDM system	41
3.5	Inter carrier interference (ICI) in OFDM system	44
3.5.1	OFDM system description	44
3.5.2	Analysis of inter-carrier interference	46
<b>CHAPTER 4</b>		<b>48-57</b>
	<b>NOISE BUCKET EFFECT</b>	<b>48</b>
4.1	Impulse noise and its effects in OFDM	48
4.2	Impulsive noise suppression in OFDM based communication systems	49
4.2.1	System model	50
4.3	Impulse noise mitigation for OFDM using decision directed noise estimation	51
4.3.1	New impulse mitigation technique	52
4.3.2	Impulse noise models	54
4.4	Performance comparison of ATSC 8-VSB and DVB-T COFDM transmission systems for digital television terrestrial broadcasting	55
4.4.1	General system comparison	55
4.5	MFN vs. SFN operation	56

**CHAPTER 5**

**58-62**

SIMULATION RESULTS FOR OFDM SYSTEMS WORKING UNDER  
IMPULSIVE NOISE ENVIRONMENT. 58

**CHAPTER 6**

**63-64**

CONCLUDING REMARKS AND FUTURE SCOPE 63

**REFERENCES**

**65-69**

## LIST OF ABBREVIATION

ADC	analog to digital convertor
ADSL	asymmetric digital subcarrier line
ATSC	advance Television system committee
AWGN	additive white Gaussian noise
BER	bit error rate
BST	bandwidth segmented transmission
CDMA	code division multiple access
COFDM	coded orthogonal division multiplexing
DAB	digital audio broadcast
DMT	discrete multi tone modulation
DTTB	digital Television terrestrial broadcast
DTV	digital Television
DVB	digital video broadcast
DVB-T	digital video broadcast terrestrial
FFT	fast Fourier transform
FM	frequency modulation
GI	guard interval
HDSL	high rate digital subcarrier line
HDTV	high definition Television

ICI	inter carrier interference
IDFT	inverse discrete Fourier transform
ISI	inter symbol interference
MFN	multi frequency network
MIMO	multi input multi output
MLSE	maximum likelihood sequence estimation
OFDM	Orthogonal frequency division multiplexing
PLC	power line communication
PSK	phase shift keying
QAM	quadrature amplitude modulation
RS	reed solomon
SER	symbol error rate
SFN	single frequency network
SNR	signal to noise ratio
WiMAX	worldwide interoperability for microwave access

## LIST OF FIGURES

<b>Figure No.</b>	<b>Page No.</b>
Figure 1 Effect of a fade on serial and parallel system	1
Figure 2 Sub carrier OFDM transmitter	3
Figure 3 Spectra of three orthogonal subcarriers	5
Figure 4 Spectra of three no-orthogonal subcarriers	5
Figure 5 OFDM model used for simulation	8
Figure 6 OFDM-RS code in channel with impulsive noise of long duration	20
Figure 7 OFDM-RS code in channel with impulsive noise of short duration	21
Figure 8 OFDM-RS code $N=32, K=24$ in channel with AWGN	22
Figure 9 Block scheme of transmission system	24
Figure 10 Simplified block diagram of a bit interleaved coded OFDM system	30
Figure 11 Block diagram of the proposed iterative receiver for bit interleaved coded OFDM	32
Figure 12 Power spectrum of the transmitted signal	33
Figure 13 OFDM system implementation	35

<b>Figure No.</b>	<b>Page No.</b>
Figure 14 symbol structure	35
Figure 15 Signal model	36
Figure 16 ISI from symbol i-1	37
Figure 17 BER VS SNR for OFDM-BPSK system	40
Figure 18 BER VS SNR for OFDM-QPSK system	40
Figure 19 Block diagram MIMO	42
Figure 20 BER performance of MIMO-OFDM	43
Figure 21 Baseband OFDM transceiver system	45
Figure 22 Frequency offset model	46
Figure 23 ICI coefficients for N=16 carriers	47
Figure 24 Block diagram of receiver with impulse mitigation	53
Figure 25 Symbol error rate vs SNR for different no. of Impulses	59
Figure 26 SER vs Impulse level for different no. of Impulses	60
Figure 27 SER vs Amplitude of Impulses for different no. of Sub-carriers	61

INTRODUCTION

1.1 Overview of OFDM

The concept of using parallel data transmission by means of frequency division multiplexing (FDM) was published in mid 60[1, 2]. Some early developers can be traced back in the 50's a U.S. patent was filled and issued in January, 1970. The idea was to use parallel data streams and FDM with overlapping sub-channels to avoid the use of high speed equalization, and to combat impulsive noise, and multipath distortion as well as to fully use the available bandwidth. The initial applications were in the military communications. In the telecommunications field, the term of discrete Multi-tone, multi-channel modulation and multi-carrier modulation (MCM) are widely used and sometimes they are interchangeable with OFDM. In OFDM, each carrier is orthogonal to all other carriers. However, this condition is not always maintained in MCM. OFDM is an optimum version of multicarrier transmission schemes [3].

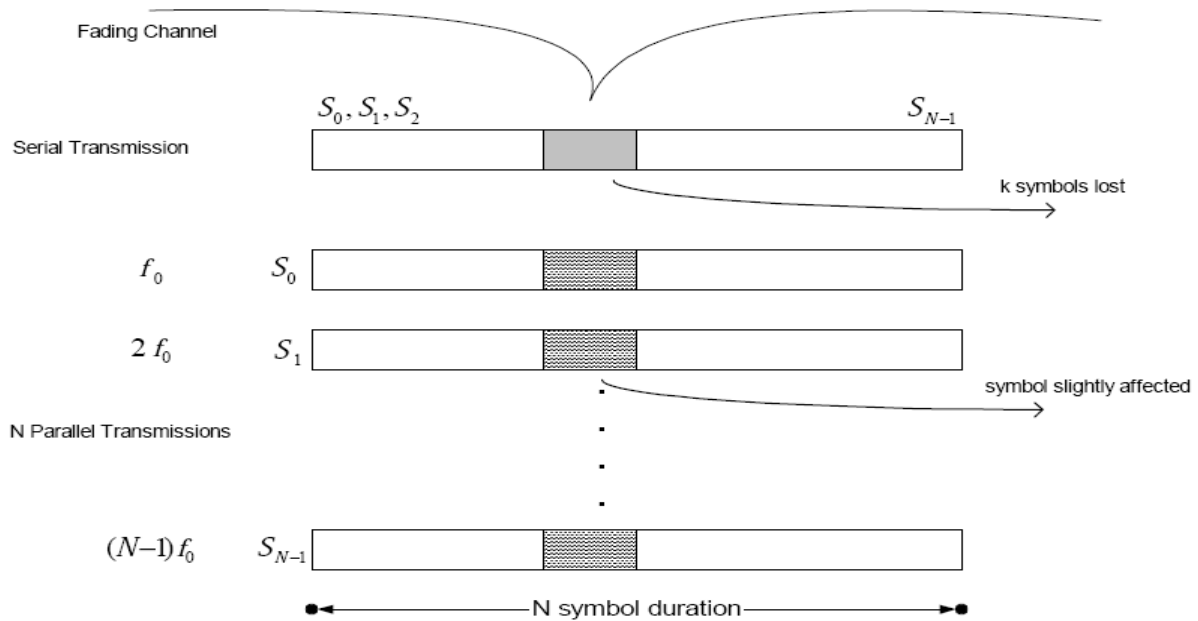

Figure 1 Effect of a fade on serial and parallel system

For a large number of sub-channels, the arrays of sinusoidal generators and coherent demodulator require in parallel system become unreasonably expensive and complex. The receiver needs precise phasing of the demodulator carriers and sampling times in order to keep crosstalk between sub-channels acceptable. Weinstein and Ebert [4] applied the discrete Fourier transform to parallel data as part of modulation and demodulation process. But the problem with FFT is that here we can use only limited frequencies, which are the integral multiples of  $1/T$ , where  $T$  is the symbol time period. In the 1980's, OFDM was studied for high-speed modems, digital mobile communications [5] and high density recording. One of the systems, used a pilot tone [6] for stabilizing carrier and clock frequency control and trellis coding was implemented. In 1990's, OFDM was exploited for wideband data communications over mobile radio FM channels, high bit-rate digital subscriber line, asymmetric digital subscriber line, very high speed digital subscriber lines, digital audio broadcasting (DAB) [7] and HDTV terrestrial broadcasting.

## 1.2 Generation of OFDM symbols

A baseband OFDM symbol can be generated in the digital domain before modulating on a carrier for transmission. To generate a baseband OFDM symbol, a serial digitized data stream is first modulated using common modulation schemes such as the phase shift keying (PSK) or quadrature amplitude modulation (QAM). These data symbols are then converted to parallel streams before modulating subcarriers. Subcarriers are sampled with sampling rate  $N/T_s$ , where  $N$  is the number of subcarriers and  $T_s$  is the OFDM symbol duration. The frequency separation between two adjacent subcarriers is  $2\pi/N$ . Finally, samples on each subcarrier are summed together to form an OFDM sample. An OFDM symbol generated by an  $N$ -subcarrier OFDM system consists of  $N$  samples and the  $m$ th sample of an OFDM symbol is given by [8] equation (1)

$$x_m = \sum_{n=1}^{N-1} X_n e^{j \frac{2\pi mn}{N}} \quad 0 \leq m \leq N-1 \quad (1)$$

Where  $X_n$  is the transmitted data symbol on the  $n$ th carrier. Equation (1) is equivalent to the  $N$  point inverse discrete Fourier transform (IDFT) operation on the data sequence with the omission of a scaling factor. It is well known [9] that IDFT can be implemented efficiently using inverse fast Fourier transform (IFFT). Therefore, in practice, the IFFT is performed on the data sequence

at an OFDM transmitter for baseband modulation and the FFT is performed at an OFDM receiver for baseband demodulation. Size of FFT and IFFT is  $N$ , which is equal to the number of sub channels available for transmission, but all of the channels needs to be active. The sub-channel bandwidth is given by equation (2):

$$f_{sc} = \frac{1}{T_s} = \frac{f_{samp}}{N} \quad (2)$$

Where  $f_{samp}$  is the sample rate and  $T_s$  is the symbol time.

Finally, a baseband OFDM symbol is modulated by a carrier to become a band-pass signal and transmitted to the receiver. In the frequency domain, this corresponds to translating all the subcarriers from baseband to the carrier frequency simultaneously. Figure 2 shows a 3-subcarrier OFDM transmitter and the process of generating one OFDM symbol.

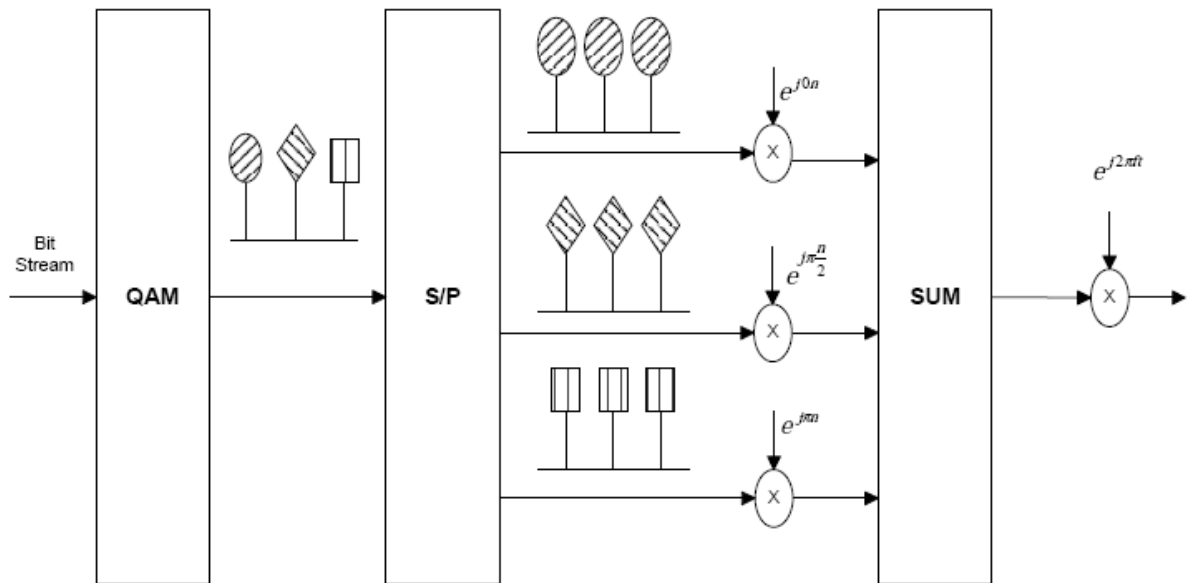
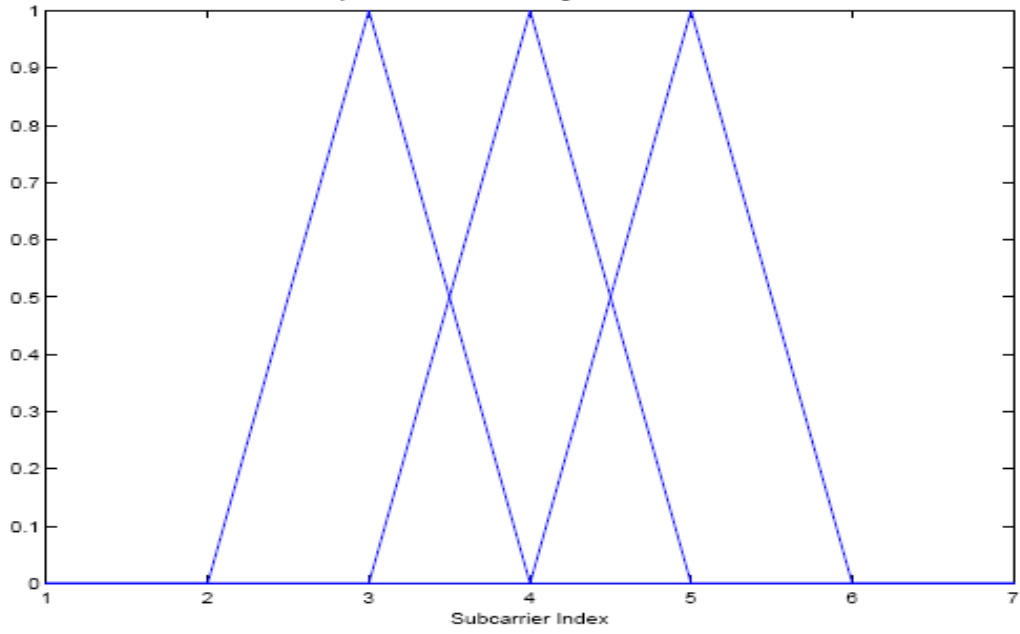

**Figure 2 Sub carrier OFDM transmitter.**

### 1.3 Inter-symbol and Inter-carrier interference

In a multipath environment, a transmitted symbol takes different times to reach the receiver through different propagation paths. From the receivers' point of view, the channel introduces time dispersion in which the duration of the received symbol is stretched. Extending the symbol duration causes the current received symbol to overlap previous received symbols and results in inter-symbol interference (ISI) [10]. In OFDM, ISI usually refers to interference of an OFDM symbol by previous OFDM symbols. In OFDM, the spectra of subcarriers overlap but remain orthogonal to each other. This means that at the maximum of each subcarrier spectrum, all the spectra of other subcarriers are zero [11]. The receiver samples data symbols on individual subcarriers at the maximum points and demodulates them free from any interference from the other subcarriers. Interference caused by data symbols on adjacent subcarriers is referred to inter-carrier interference (ICI).

The orthogonality of subcarriers can be viewed in either the time domain or in frequency domain. From the time domain perspective, each subcarrier is a sinusoid with an integer number of cycles within one FFT interval. From the frequency domain perspective, this corresponds to each subcarrier having the maximum value at its own center frequency and zero at the center frequency of each of the other subcarriers. Figure 3 shows the spectra of four subcarriers in the frequency domain for the orthogonality case. The orthogonality of a subcarrier with respect to other subcarriers is lost if the subcarrier has nonzero spectral value at other subcarrier frequencies. From the time domain perspective, the corresponding sinusoid no longer has an integer number of cycles within the FFT interval. Figure 4 shows the spectra of four subcarriers in the frequency domain when orthogonality is lost. ICI occurs when the multipath channel varies over one OFDM symbol time [12]. When this happens, the Doppler shifts on each multipath component cause a frequency offset on the subcarriers, resulting in the loss of orthogonality among them. This situation can be viewed from the time domain perspective, in which the integer number of cycles for each subcarrier within the FFT interval of the current symbol is no longer maintained due to the phase transition introduced by the previous symbol. Finally, any offset between the subcarrier frequencies of the transmitter and receiver also introduces ICI to an OFDM symbol.



**Figure 3 Spectra of three orthogonal subcarriers**

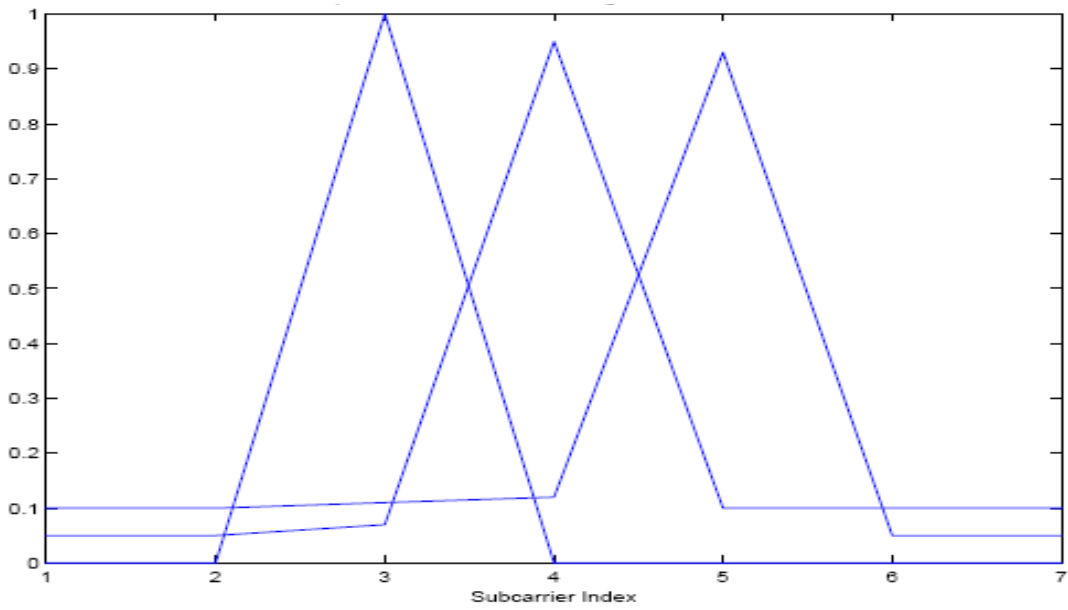

**Figure 4 Spectra of three non-orthogonal subcarriers**

## **1.4 Orthogonal frequency-division multiplexing**

Orthogonal frequency-division multiplexing (OFDM), essentially identical to coded OFDM (COFDM) and discrete multi-tone modulation (DMT), is a frequency-division multiplexing (FDM) scheme used as a digital multi-carrier modulation method. A large number of closely-spaced orthogonal sub-carriers are used to carry data. The data is divided into several parallel data streams or channels, one for each sub-carrier. Each sub-carrier is modulated with a conventional modulation scheme (such as quadrature amplitude modulation or phase-shift keying) at a low symbol rate, maintaining total data rates similar to conventional single-carrier modulation schemes in the same bandwidth.

OFDM has developed into a popular scheme for wideband digital communication, whether wireless or over copper wires, used in applications such as digital television and audio broadcasting, wireless networking and broadband internet access.

The primary advantage of OFDM over single-carrier schemes is its ability to cope with severe channel conditions (for example, attenuation of high frequencies in a long copper wire, narrowband interference and frequency-selective fading due to multipath) without complex equalization filters. Channel equalization is simplified because OFDM may be viewed as using many slowly-modulated narrowband signals rather than one rapidly-modulated wideband signal. The low symbol rate makes the use of a guard interval between symbols affordable, making it possible to eliminate inter-symbol interference (ISI) and utilize echoes and time-spreading (that shows up as ghosting on analogue TV) to achieve a diversity gain, i.e. a signal-to-noise ratio improvement. This mechanism also facilitates the design of single frequency networks (SFNs), where several adjacent transmitters send the same signal simultaneously at the same frequency, as the signals from multiple distant transmitters may be combine constructively, rather than interfering as would typically occur in a traditional single-carrier system

## **1.5 Characteristics and principles of operation**

### **1.5.1 Orthogonality**

In OFDM, the sub-carrier frequencies are chosen so that the sub-carriers are orthogonal to each other, meaning that cross-talk between the sub-channels is eliminated and inter-carrier guard

bands are not required. This greatly simplifies the design of both the transmitter and the receiver; unlike conventional FDM, a separate filter for each sub-channel is not required. The orthogonality requires that the sub-carrier spacing is  $\Delta f = \frac{k}{T_u}$  Hertz, where  $T_u$  seconds is the useful symbol duration (the receiver side window size), and  $k$  is a positive integer, typically equal to 1. Therefore, with  $N$  sub-carriers, the total passband bandwidth will be  $B \approx N \cdot \Delta f$  (Hz). The orthogonality also allows high spectral efficiency, with a total symbol rate near the Nyquist rate for the equivalent baseband signal (i.e. near half the Nyquist rate for the double-side band physical passband signal). Almost the whole available frequency band can be utilized. OFDM generally has a nearly 'white' spectrum, giving it benign electromagnetic interference properties with respect to other co-channel users. A simple example: A useful symbol duration  $T_u = 1$  ms would require a sub-carrier spacing of  $\Delta f = \frac{1}{1ms} = 1Khz$  (or an integer multiple of that) for orthogonality.  $N = 1,000$  sub-carriers would result in a total passband bandwidth of  $N\Delta f = 1$  MHz. For this symbol time, the required bandwidth in theory according to Nyquist is  $N/2T_u = 0.5$  MHz (i.e., half of the achieved bandwidth required by our scheme). If a guard interval is applied (see below), Nyquist bandwidth requirement would be even lower. The FFT would result in  $N = 1,000$  samples per symbol. If no guard interval was applied, this would result in a base band complex valued signal with a sample rate of 1 MHz, which would require a baseband bandwidth of 0.5 MHz according to Nyquist. However, the pass band RF signal is produced by multiplying the baseband signal with a carrier waveform (i.e., double-sideband quadrature amplitude-modulation) resulting in a pass band bandwidth of 1 MHz. A single-side band (SSB) or vestigial sideband (VSB) modulation scheme would achieve almost half that bandwidth for the same symbol rate (i.e., twice as high spectral efficiency for the same symbol alphabet length). It is however more sensitive to multipath interference. OFDM requires very accurate frequency synchronization between the receiver and the transmitter; with frequency deviation the subcarriers will no longer be orthogonal, causing inter-carrier interference (ICI) (i.e., cross-talk between the sub-carriers). Frequency offsets are typically caused by mismatched transmitter and receiver oscillators, or by Doppler shift due to movement. While Doppler shift alone may be compensated for by the receiver, the situation is worsened when combined with multipath, as reflections will appear at various frequency offsets, which is much harder to

correct. This effect typically worsens as speed increases, and is an important factor limiting the use of OFDM in high-speed vehicles. Several techniques for ICI suppression are suggested, but they may increase the receiver complexity.

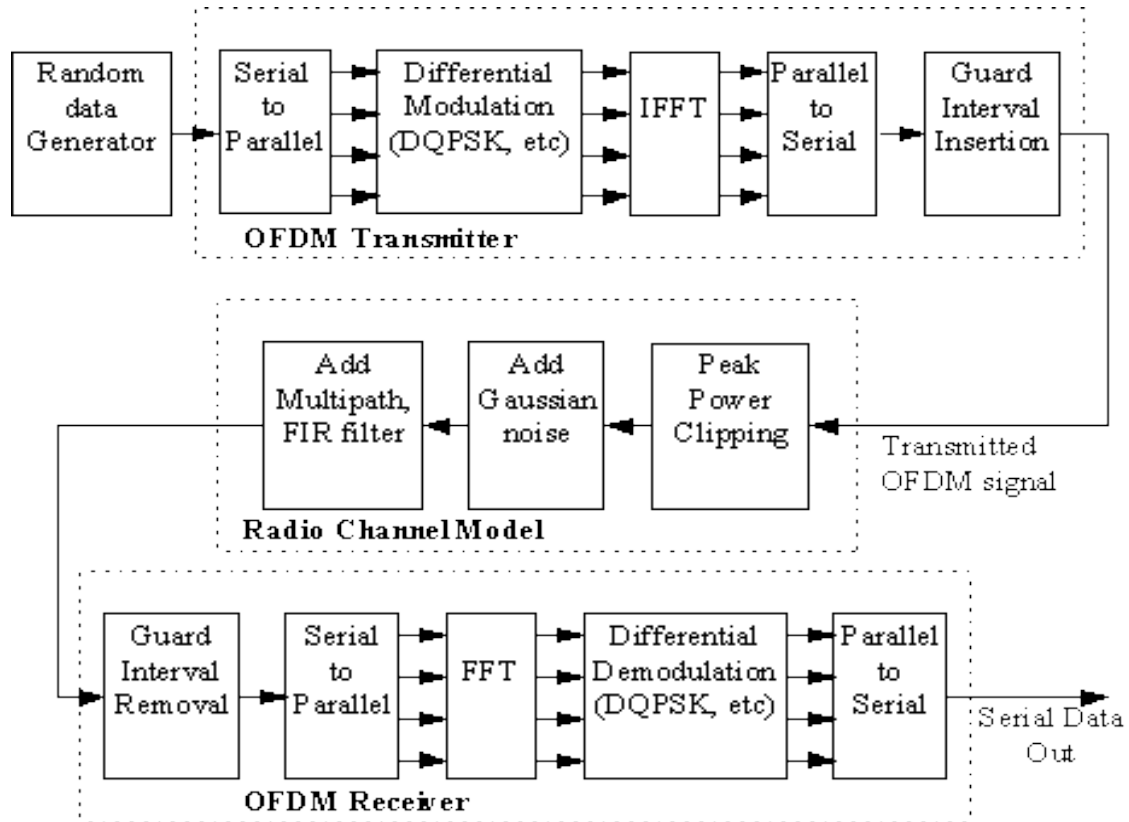

**Figure 5 OFDM model used for simulation**

### 1.5.2 Serial to parallel conversion

The input serial data stream is formatted into the word size required for transmission, e.g. 2 bits/word for QPSK, and shifted into a parallel format. The data is then transmitted in parallel by assigning each data word to one carrier in the transmission.

### 1.5.3 Modulation of data

The data to be transmitted on each carrier is then differential encoded with previous symbols, then mapped into a Phase Shift Keying (PSK) format. Since differential encoding requires an initial phase reference an extra symbol is added at the start for this purpose. The data on each symbol is then mapped to a phase angle based on the modulation method. For example, for

QPSK the phase angles used are 0, 90, 180, and 270 degrees. The use of phase shift keying produces a constant amplitude signal and was chosen for its simplicity and to reduce problems with amplitude fluctuations due to fading.

#### **1.5.4 Inverse Fourier transform**

After the required spectrum is worked out, an inverse Fourier transform is used to find the corresponding time waveform. The guard period is then added to the start of each symbol.

#### **1.5.5 Guard period**

The guard period used was made up of two sections. Half of the guard period time is a zero amplitude transmission. The other half of the guard period is a cyclic extension of the symbol to be transmitted. This was to allow for symbol timing to be easily recovered by envelope detection. However it was found that it was not required in any of the simulations as the timing could be accurately determined position of the samples. After the guard has been added, the symbols are then converted back to a serial time waveform. This is then the base band signal for the OFDM transmission.

#### **1.5.6 Channel**

A channel model is then applied to the transmitted signal. The model allows for the signal to noise ratio, multipath, and peak power clipping to be controlled. The signal to noise ratio is set by adding a known amount of white noise to the transmitted signal. Multipath delay spread then added by simulating the delay spread using an FIR filter. The length of the FIR filter represents the maximum delay spread, while the coefficient amplitude represents the reflected signal magnitude.

#### **1.5.7 Receiver**

The receiver basically does the reverse operation to the transmitter. The guard period is removed. The FFT of each symbol is then taken to find the original transmitted spectrum. The phase angle of each transmission carrier is then evaluated and converted back to the data word by demodulating the received phase. The data words are then combined back to the same word size as the original data.

### **1.5.8 Implementation using the FFT algorithm**

The orthogonality allows for efficient modulator and demodulator implementation using the FFT algorithm on the receiver side, and inverse FFT on the sender side. Although the principles and some of the benefits have been known since the 1960s, OFDM is popular for wideband communications today by way of low-cost digital signal processing components that can efficiently calculate the FFT.

### **1.5.9 Guard interval for elimination of inter-symbol interference**

One key principle of OFDM is that since low symbol rate modulation schemes (i.e., where the symbols are relatively long compared to the channel time characteristics) suffer less from inter-symbol interference caused by multipath propagation, it is advantageous to transmit a number of low-rate streams in parallel instead of a single high-rate stream. Since the duration of each symbol is long, it is feasible to insert a guard interval between the OFDM symbols, thus eliminating the inter-symbol interference. The guard interval also eliminates the need for a pulse-shaping filter, and it reduces the sensitivity to time synchronization problems. A simple example: If one sends a million symbols per second using conventional single-carrier modulation over a wireless channel, then the duration of each symbol would be one microsecond or less. This imposes severe constraints on synchronization and necessitates the removal of multipath interference. If the same million symbols per second are spread among one thousand sub-channels, the duration of each symbol can be longer by a factor of a thousand (i.e., one millisecond) for orthogonality with approximately the same bandwidth. Assume that a guard interval of 1/8 of the symbol length is inserted between each symbol. Inter-symbol interference can be avoided if the multipath time-spreading (the time between the reception of the first and the last echo) is shorter than the guard interval (i.e., 125 microseconds). This corresponds to a maximum difference of 37.5 kilometers between the lengths of the paths. The cyclic prefix, which is transmitted during the guard interval, consists of the end of the OFDM symbol copied into the guard interval, and the guard interval is transmitted followed by the OFDM symbol. The reason that the guard interval consists of a copy of the end of the OFDM symbol is so that the receiver will integrate over an integer number of sinusoid cycles for each of the multi-paths when it performs OFDM demodulation with the FFT. Simplified equalization

The effects of frequency-selective channel conditions, for example fading caused by multipath propagation, can be considered as constant (flat) over an OFDM sub-channel if the sub-channel is sufficiently narrow-banded (i.e., if the number of sub-channels is sufficiently large). This makes frequency domain equalization possible at the receiver, which is far simpler than the time-domain equalization used in conventional single-carrier modulation. In OFDM, the equalizer only has to multiply each detected sub-carrier (each Fourier coefficient) in each OFDM symbol by a constant complex number, or a rarely changed value.

Our example: The OFDM equalization in the above numerical example would require one complex valued multiplication per subcarrier and symbol (i.e.  $N = 100$ ) complex multiplications per OFDM symbol; i.e., one million multiplications per second, at the receiver). The FFT algorithm requires  $N \log_2 N = 10,000N$  complex-valued multiplications per OFDM symbol (i.e., 10 million multiplications per second), at both the receiver and transmitter side. This should be compared with the corresponding one million symbols/second single-carrier modulation case mentioned in the example, where the equalization of 125 microseconds time-spreading using a FIR filter would require, in a naive implementation, 125 multiplications per symbol (i.e., 125 million multiplications per second). FFT techniques can be used to reduce the number of multiplications for an FIR filter based time-domain equalizer to a number comparable with OFDM, at the cost of delay between reception and decoding which also becomes comparable with OFDM.

If differential modulation such as DPSK or DQPSK is applied to each sub-carrier, equalization can be completely omitted, since these non-coherent schemes are insensitive to slowly changing amplitude and phase distortion. In a sense, improvements in FIR equalization using FFTs or partial FFTs leads mathematically closer to OFDM, but the OFDM technique is easier to understand and implement, and the sub-channels can be independently adapted in other ways than varying equalization coefficients, such as switching between different QAM constellation patterns and error-correction schemes to match individual sub-channel noise and interference characteristics. Some of the sub-carriers in some of the OFDM symbols may carry pilot signals for measurement of the channel conditions (i.e., the equalizer gain and phase shift for each sub-carrier). Pilot signals and training symbols (preambles) may also be used for time

synchronization (to avoid inter symbol interference, ISI) and frequency synchronization (to avoid inter-carrier interference, ICI, caused by Doppler shift).

OFDM was initially used for wired and stationary wireless communications. However, with an increasing number of applications operating in highly mobile environments, the effect of dispersive fading caused by a combination of multi-path propagation and doppler shift is more significant. Over the last decade, research has been done on how to equalize OFDM transmission over doubly selective channels.

#### **1.5.10 Channel coding and interleaving**

OFDM is invariably used in conjunction with channel coding (forward error correction), and almost always uses frequency and/or time interleaving. Frequency (subcarrier) interleaving increases resistance to frequency-selective channel conditions such as fading. For example, when a part of the channel bandwidth fades, frequency interleaving ensures that the bit errors that would result from those subcarriers in the faded part of the bandwidth are spread out in the bit-stream rather than being concentrated. Similarly, time interleaving ensures that bits that are originally close together in the bit-stream are transmitted far apart in time, thus mitigating against severe fading as would happen when travelling at high speed. However, time interleaving is of little benefit in slowly fading channels, such as for stationary reception, and frequency interleaving offers little to no benefit for narrowband channels that suffer from flat-fading (where the whole channel bandwidth fades at the same time). The reason why interleaving is used on OFDM is to attempt to spread the errors out in the bit-stream that is presented to the error correction decoder, because when such decoders are presented with a high concentration of errors the decoder is unable to correct all the bit errors, and a burst of uncorrected errors occurs. A similar design of audio data encoding makes compact disc (CD) playback robust.

A classical type of error correction coding used with OFDM-based systems is convolutional coding, often concatenated with Reed-Solomon coding. Usually, additional interleaving (on top of the time and frequency interleaving mentioned above) in between the two layers of coding is implemented. The choice for Reed-Solomon coding as the outer error correction code is based on the observation that the Viterbi decoder used for inner convolutional decoding produces short errors bursts when there is a high concentration of errors, and Reed-Solomon codes are

inherently well-suited to correcting bursts of errors. Newer systems, however, usually now adopt near-optimal types of error correction codes that use the turbo decoding principle, where the decoder iterates towards the desired solution. Examples of such error correction coding types include turbo codes and LDPC codes, which perform close to the Shannon limit for the Additive White Gaussian Noise (AWGN) channel. Some systems that have implemented these codes have concatenated them with either Reed-Solomon (for example on the Media FLO system) or BCH codes (on the DVB-S2 system) to improve upon an error floor inherent to these codes at high signal-to-noise ratios.

## **1.6 Problem statement**

- 1) Investigation of the noise bucket effects on OFDM systems.
- 2) Investigation of statistical properties of impulsive noise on OFDM systems through Matlab simulation.

## **1.7 Organization of thesis**

This thesis is organized in six Chapters

Chapter 1 summarizes the basic problem statement of research work and give the over view of the OFDM and its characteristics.

In Chapter 2, we review the related work done in the area of OFDM. We also presented the effect of impulse noise on OFDM.

In chapter 3, gives the overview of basic OFDM model for communication, and also shows the effect of using OFDM on different conditions.

In chapter 4, we describe the concept of noise bucket effect on OFDM, resulting in suppression of impulsive noise.

In chapter 5, the simulation results of OFDM under different impulsive noise conditions are shown. All the simulation are done using MATLAB.

Finally, in chapter 6, we concluded our work done on impulsive noise in OFDM based communication systems.

### LITERATURE SURVEY

#### 2.1 Noise bucket effect for impulse noise in OFDM

Impulse noise is a significant problem in some orthogonal frequency division multiplexing (OFDM) applications. It has been observed in practice that the degradation caused by impulse noise depends only on the total energy of the noise during each OFDM symbol, not on the structure of the noise. This ‘noise bucket’ effect is explained by showing that even for a small number of impulses per symbol the noise distribution at the input of the receiver decision device is close to Gaussian. This is because of the spreading effect of the discrete Fourier transform. One of the advantages of orthogonal frequency division multiplexing (OFDM) compared to single carrier systems is its robustness against impulse noise. However impulse noise is still a serious problem in OFDM based systems including digital video broadcasting (DVB) [13] and several techniques to mitigate the effects of impulse noise have been proposed [14, 15]. There are many different sources of impulse noise such as car ignitions, high voltage cables and domestic electrical appliances such as hair dryers and microwave ovens, thus it is difficult to model the details of impulse noise accurately. However it has recently been observed that in practice the system degradation caused by impulse noise in DVB systems depends only on the total noise energy within one OFDM symbol period, not on the detailed distribution of the noise energy within the symbol. This has been described as an extension of the ‘noise bucket’ effect [16]. In this, we present a theoretical explanation for this practical observation and show that it is true for a wide range of OFDM systems and forms of impulse noise. In OFDM, decisions about the transmitted data are based on the signals at the output of the receiver discrete Fourier transform (DFT). We show that even when the noise at the receiver is impulsive, the noise after the DFT is approximately Gaussian. This is a result of the spreading effect of the DFT. Thus irrespective of the detailed structure of the impulse noise, the error rate which is observed is approximately the same as the error rate that would result for Gaussian noise with the same total energy per symbol.

### 2.1.1 Impulse noise and its effects in OFDM:

Impulse noise can potentially affect a number of receiver functions. For example, it can cause the input amplifier to overload or disrupt the automatic gain control. These effects are not considered here, here only the effect of impulse noise on the baseband digital section of the receiver is considered.

The received time domain baseband OFDM signal is mathematically expressed as equation (3)

$$r(k) = x(k) = n(k) + i(k) \quad (3)$$

where  $x(k)$  is the wanted OFDM signal,  $n(k)$  is additive white Gaussian noise (AWGN) with zero mean and variance  $E\{|n(k)|^2\} = \sigma n^2$  and  $i(k)$  is the impulse noise. The statistical properties of  $i(k)$  depend on both the form of impulse noise at the receiver input and on the filtering properties of the receiver front end. A number of impulse noise models based on theoretical analysis or experimental data have been presented in previous literature. However very recent research by the BBC, which measured a variety of impulse noise sources of practical importance in OFDM applications, concluded that impulse noise can be modeled as gated Gaussian noise.

The ‘noise bucket’ concept applies in quantifying the performance of OFDM impaired by impulse noise. The decision noise becomes approximately Gaussian even with a small number of impulse occurrences. The theoretical and simulation results for system SER agree closely.

## 2.2 Impulse noise cancellation in the system with OFDM modulation

Orthogonal Frequency Division Multiplex (OFDM) is recently widely used in many wireless and wire line communication systems. The parallelism between RS code and OFDM modulation with consecutive suppressed carriers is known. Here, the capability of OFDM modulation to act as an error correcting code is analyzed if used for transmission over channel with impulsive noise. New decoding algorithms of OFDM-RS code are presented with emphasis on the low implementation complexity. The decoding and error correcting performance of these new algorithms has been evaluated in series of simulations. As the channel model for simulations, Power Line Communication channel has been selected. Results of these simulations are presented as well. Here, we proposed the new way of the impulsive noise correction based on the “OFDM-RS” coding techniques. The new decoding algorithms for these codes based on various

applications of the “intelligent brute force” and dictionary based methods are proposed and analyzed. In contrast to already well known decoding algorithms, are these ones much simpler and closer to the implementation in the real communication systems? Besides the algorithms also controlling procedure for estimation quality of decoding and malfunction detection of the decoding algorithm is described. The performance verification of the proposed codes and their decoding algorithms has been performed in the Broadband Power Line transmission environment. The algorithms were tested in three different noise scenarios in environment with long lasting, short lasting and finally with AWGN noise. The simulations proved good impulsive noise errors correcting capability, especially when the syndrome based decoding algorithm with soft decision approach has been used. Worse results have been achieved in channel with Gaussian background noise, but this is well known fact that DTF based codes have limited capability to cope with this type of noise. However the proposed algorithms represent just the initial approach and authors see a lot of space for optimization to improve their performance in case of usage in other than impulsive noise environments.

### **2.3 Analysis of OFDM receiver with blanking nonlinearity in impulsive noise environment**

Orthogonal frequency division multiplexing (OFDM) is an effective multicarrier transmission scheme suitable for high data rate wireless applications. OFDM has several advantages over single-carrier systems, particularly its robustness to multipath propagation, and efficient implementation based on fast Fourier transform (FFT). One of the challenging problems in practical applications of wireless digital communication techniques is data transmission over channels with man-made noise that appears in typical urban environments. The manmade noise created by vehicle ignition systems, power lines, heavy current switches, and other sources cannot be assumed to be Gaussian, and must be represented by impulsive models[17,18]. In general, OFDM systems are less sensitive to impulsive noise than single carrier systems. The longer OFDM symbol duration provides an advantage, since the impulsive noise energy is spread among simultaneously transmitted OFDM subcarriers. However, it has been recently recognized that this advantage turns into a disadvantage if impulsive noise energy exceeds a certain threshold. A simple method of reducing the adverse effect of impulsive noise is to precede conventional OFDM demodulators with blanking nonlinearity. This method is widely used in

practice, because it is very simple to implement and provides an improvement over conventional OFDM demodulators in impulsive noise channels. However, performance analysis of this scheme has not yet appeared. Here, we address the problem of optimal threshold selection and performance characterization of an OFDM receiver that uses blanking nonlinearity for impulsive noise cancellation. It should be noted that the idea of using blanking nonlinearity (also referred to as a blanker or hole puncture) for impulsive noise cancellation is not new. It was shown over four decades ago that the locally optimal detector for arbitrary signals in impulsive noise under a low signal-to-noise ratio (SNR) assumption is comprised of a conventional detector (optimal in a Gaussian noise environment) preceded by a memory less nonlinearity [19, 20]. Generally, the shape of the optimal memory less nonlinearity is determined by the probability density function of the impulsive noise process. However, it is shown that the blanking nonlinearity is one of the best (and the simplest) approximations to the locally optimal nonlinear preprocessor [21]. Recently, the idea of using (suboptimal) blanking nonlinearity for impulsive noise cancellation has been successfully applied to modern OFDM communication systems. It should also be noted that the performance of receivers with blanking nonlinearity. However, the analysis presented in [21] relies on a weak signal assumption, which is not valid for most of the modern OFDM systems in a typical impulsive noise environment. Moreover, the performance studies carried out in the past were based on computer simulations or numerical methods. Unlike the previous studies here, we provide theoretical analysis that does not rely on the small signal assumption. The only assumption made is that the OFDM signal with large number of subcarriers can be modeled as a complex Gaussian process with Rayleigh envelope distribution [22]. The primary objectives of this study are: To find the optimal blanking threshold for the OFDM receiver with blanking nonlinearity under various impulsive noise scenarios and to determine the worst-case impulsive noise scenario for the OFDM receiver with blanking nonlinearity.

These two problems are essential for the development of practical adaptive receivers (i.e., receivers that use adaptive blanking threshold) and for laboratory tests of the OFDM receivers employing blanker or other techniques for impulsive noise cancellation. The performance of the optimized OFDM receiver with blanker can also serve as a benchmark for comparison with more sophisticated impulsive noise cancellation techniques. So in, closed-form expressions for performance characterization of the OFDM receiver with blanking nonlinearity in the presence of impulsive noise were derived. Simulation results show that the proposed analysis provides

very good prediction of the output signal-to-noise ratio (SNR) and satisfactory approximation of the symbol-error rate (SER) if the number of OFDM subcarriers is sufficiently large. Based on this analysis, we propose a threshold optimization procedure. The analysis shows that there is a worst-case signal-to-impulsive noise ratio (SINR) that maximizes noise power in an OFDM receiver with blanking nonlinearity. The worst-case scenario corresponds to intermediate SINR values ( $-6$  dB . . .  $-9$  dB, for given examples). It is shown that the poor performance of the OFDM receiver with blanking nonlinearity in the intermediate SINR region is mainly caused by imperfect detection of the signal samples affected by impulsive noise. An enhanced detection procedure may significantly improve overall performance of the OFDM receiver in an impulsive noise environment. This topic, along with improved SER estimation, is the subject for future research.

## **2.4 Impulsive noise cancellation in systems with OFDM modulation**

Orthogonal frequency-division multiplexing (OFDM) system represents very popular and broadly used modulation technique. Although it is based on principles which are quite old, thanks to the progress in development of fast signal-processing components and other supporting technologies in the near past, it was incorporated into many communication systems of recent days. It can be found in European digital audio and video broadcasting (HD-Radio, DVB-T, DVB-H), in wireless communication standards (IEEE 802.11a/g, WiMAX), mobile communication systems (IEEE 802.20, Flash-OFDM) and also in Xdsl systems. It is a candidate for modulation technique for Power Line Communication systems as well. All communication channels mentioned above suffer from the same very disrupting phenomenon — impulsive noise. It can be described as an additive disturbance that is caused by switching electric equipment in the transmission environment. Depending on the environment its amplitude can reach several dB over background noise and from spectral perspective the pulse has a pole and infinite energy. The consequence is the occurrence of isolated or more often bursty errors even if OFDM modulation is used. To be able to decrease the impact of this kind of noise on transmitted signal a very robust and powerful encoding scheme is needed. The drawback of such a approach is high redundancy added to the useful information. It results in the lower efficiency of transmission. To overcome this shadow side of encoding there would be an option to use already existing redundancy. One such a source of the redundant information could be OFDM modulation itself.

One of such a useful forms of redundancy in OFDM can be sequence of consecutive null symbols appended to the block of information symbols due to over sampling, spectral restrictions or spectral adaptability. As it was already shown in the OFDM is a Reed-Solomon code and it can be used as a specific impulsive noise canceller [23]. Because of the nature of impulsive noise (one impulse = one symbol error) it is more suitable for its cancellation than the classical FEC decoder. However the classical FEC code is also necessary, since the impulsive noise is not the one and only negative phenomenon in the common transmission channels. Several approaches based on OFDM modulation has been already proposed concerning mainly usage of the Bose Chaudhuri Hocquengem (BCH) code in the complex and real field in order to minimize the effect of the minor errors caused by the impulsive noise. Most of them are based on algorithms known for codes defined over Galois fields. For example Wolf used BCH codes in [24] and Abdelkefi in [23], Marvasti in and Kumaresan in [25] used RS codes in cooperation with DFT. Wu has even defined a class of the real-number block codes using the discrete cosine transform. For decoding he also used a modified Berlekamp-Massey algorithm and Forney algorithm. All these authors used similar decoding algorithms based on the already well known techniques for decoding RS or BCH codes over finite fields. They have modified them by introducing different thresholds based often on empirical estimations from simulations. The thresholds are used for taking decisions about further progress in decoding algorithms in contrast to exact results from calculations over finite fields. All of them are very sensitive to the errors caused by AWGN noise and have problems with stability and quite high complexity because of the certain amount of indeterminateness in their calculations.

Both syndrome based decoding algorithms mentioned in the previous chapter (hard decision and soft decision approach) have been evaluated in the simulations. Since impulsive noise is significant in the PLC channel, the transmission through model of such a channel has been simulated. The transmitted sequence has been encoded with OFDM-RS code then transferred through the channel, received and decoded using decoding algorithms described in the text above. Simulation of the impulsive noise was part of the channel model. Although in the PLC channel different types of impulsive noises are present, one can identify these two basic categories; background and impulsive noise. Based on this fact there was simulated only the final impact of the impulsive noise on the transmitted sequence as the result of all this particular noises. Thanks to this generalization two scenarios could be distinguished for channel with

impulsive noise. In first one the impulsive noise with short duration of noise impulses was assumed. Short duration means that only one symbol of transmitted sequence has been corrupted. In second case there was ingested the impulsive noise with long impulses where more than one (two or three) symbol has been corrupted. Besides impulsive noise also impact of AWGN noise was simulated. The simulations have been done in software tool Matlab v7. In presented simulations there were  $N = 32$  carriers used for transmission in OFDM modulation. Since the oversampling was applied the IDFT/DFT was calculated from 64 samples. Also both decoding algorithms were working over 64 samples. The length of the guard interval was 16 samples. Among these 32 carriers 8 or 4 (depending on type of code) consecutive ones were equaled to zero. The remaining  $K = 24$  or  $K = 28$  were used for transmitting data information with 8-QAM modulation used within each carrier.

With settings described above several simulations has been done to prove the impulsive noise removing capability of OFDM-RS codes and our proposed decoding algorithms. Simulations are organized in the similar way and as the result the symbol error rate (SER) is plotted as a function of SNR (dB) for three different decoding algorithms; no error-correcting minimum distance decoding, syndrome based decoding algorithm with hard decision approach and syndrome based decoding algorithm with soft decision approach. The Figure 6 depicts the situation when very low level of AWGN noise and impulsive noise of short duration is present in the PLC channel. It is clearly visible the difference between all three decoding techniques, best results are achieved with soft decision approach of the syndrome based decoding against the hard decision approach (coding gain about 6 dB) and the worst with minimum distance decoding

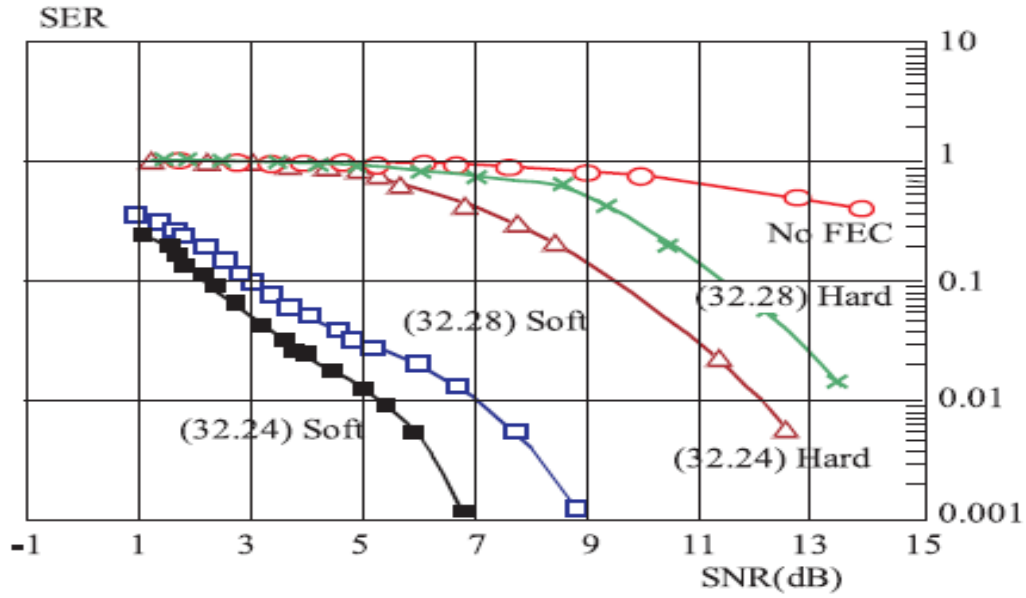

Figure 6 OFDM-RS code in channel with impulsive noise of long duration

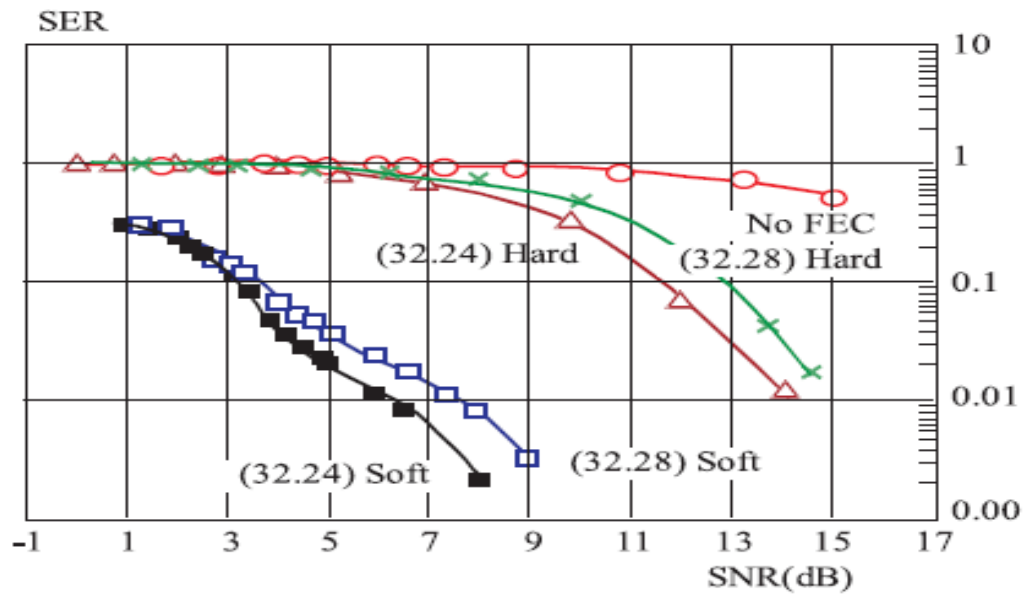
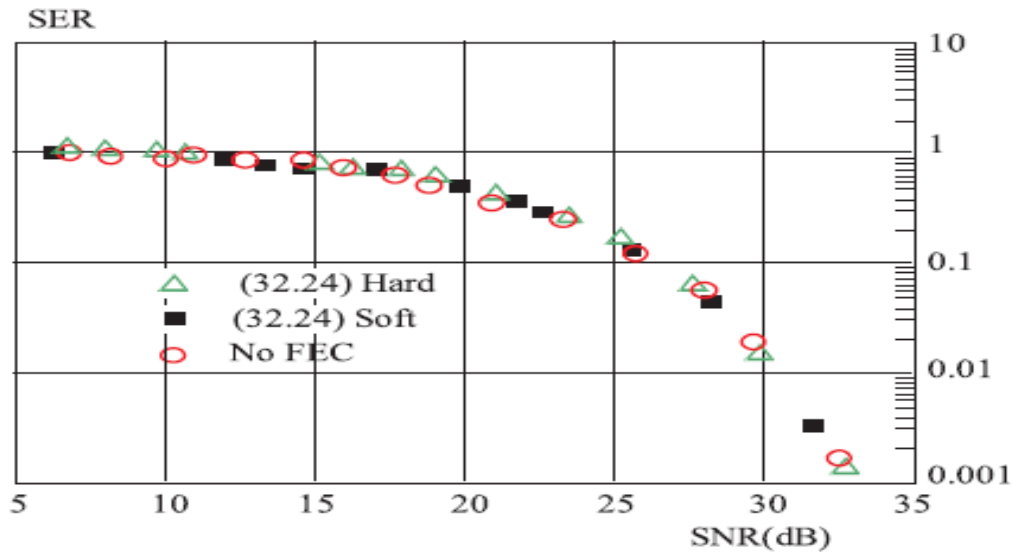

Figure 7 OFDM-RS code in channel with impulsive noise of short duration



**Figure 8 OFDM-RS code N=32,K=24 in channel with AWGN**

Also comparison of the codes reveals us visible difference in correcting capabilities of the OFDM-RS (32, 24) and OFDM-RS (32, 28) code. The difference is about 2 dB and as expected in favor of OFDM-RS (32, 24). Figure 7 shows the situation when long impulsive noise and low level of the AWGN noise is presented in the transmission channel. The results are similar to the previous case, where the best capability of correcting errors is achieved with soft decision approach (coding gain is 7 dB in comparison with hard decision), then hard decision approach follows and the last is minimum distance decoding. As expected also for this type of noise, OFDM-RS (32, 24) has performed slightly better than OFDM-RS (32, 28) code, in concrete values the gain for soft decision approach was 1.5 dB and for hard decision approach about 1 dB in favour of OFDM-RS (32, 24). Both figures reveals also the fact that the long lasting impulsive noise has worse impact on the transmitted information as short one and all analyzed decoding techniques can less successfully cope with it. The difference is about 1–1.5 dB. The last series of simulations analyze the ability of the OFDM-RS code to cope with the AWGN noise. In comparison to the previous simulations, now the impulsive noise was completely suppressed and only AWGN noise was presented but with more than 20 times higher variance value than before. Figure 8 depicts us the results from these simulations. To make the picture clearer and more easily readable there are showed results only from OFDM-RS (32, 24) code since previous simulations has already proved the better results of the code with these parameters. Again there

are compared all three decoding algorithms. As one can see the best results has been achieved with syndrome based algorithm with soft decision approach, but the differences are minimal. This reveals a very poor ability of the OFDM-RS codes to protect the useful signal against the impact of the Gaussian background noise.

In this seminar report we proposed the new way of the impulsive noise correction based on the “OFDM-RS” coding techniques. The new decoding algorithms for these codes based on various applications of the “intelligent brute force” and dictionary based methods are proposed and analyzed. In contrast to already well known decoding algorithms, are these ones much simpler and closer to the implementation in the real communication systems? Besides the algorithms also controlling procedure for estimation quality of decoding and malfunction detection of the decoding algorithm is described. The performance verification of the proposed codes and their decoding algorithms has been performed in the Broadband Power Line transmission environment. The algorithms were tested in three different noise scenarios; in environment with long lasting, short lasting and finally with AWGN noise. The simulations proved good impulsive noise errors correcting capability, especially when the syndrome based decoding algorithm with soft decision approach has been used. Worse results have been achieved in channel with Gaussian background noise, but this is well known fact that DTF based codes have limited capability to cope with this type of noise. However the proposed algorithms represent just the initial approach and authors see a lot of space for optimization to improve their performance in case of usage in other than impulsive noise environments.

## **2.5 Analysis of simple impulsive noise mitigation schemes for OFDM receiver and its system model**

One of the challenging problems in practical applications of digital communication techniques is reliable data transmission over wireless links in spite of man-made noise interference typical in urban environments. The man-made noise created by power lines, heavy current switches and other sources cannot be assumed to be Gaussian, and must be represented by impulsive models [26]. Generally, orthogonal frequency division multiplexing (OFDM) systems are inherently robust to impulsive interference [27]. The longer duration of OFDM symbols provide an advantage, since the impulsive noise energy is spread among simultaneously transmitted OFDM subcarriers. Nevertheless, this advantage may turn into a disadvantage if impulsive noise energy

exceeds a certain threshold. A simple method of reducing the adverse effect of impulsive noise is to precede a conventional OFDM demodulator with memory-less nonlinearity [28]. In [29] it is shown that under a low signal-to-noise ratio (SNR) assumption the locally optimal detector for arbitrary signals in impulsive noise comprises of a conventional detector (optimal in Gaussian noise) preceded by a memory-less nonlinearity. Recently, the idea of using suboptimal clipping or blanking techniques for impulsive noise mitigation has been applied to modern OFDM receivers [28, 30]. The aim of our study is to propose an analytical technique for performance assessment of OFDM receivers with three popular types of memory-less nonlinearity (clipping, blanking and combined clipping-blanking), and to compare the performance of these schemes in various impulsive noise scenarios.

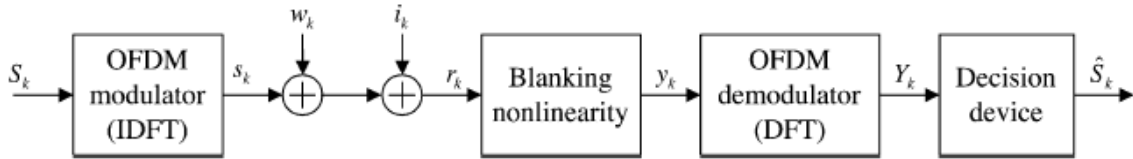

**Figure 9 Block scheme of transmission system**

Consider the model of the OFDM transmission system shown in Figure 9. First, in the OFDM transmitter, information bits are mapped into baseband symbols  $S_k$  using phase shift keying (PSK), or the quadrature amplitude modulation (QAM) scheme. During an active symbol interval the block of  $N$  complex baseband symbols is transformed by means of inverse discrete Fourier transform (IDFT) and digital-to-analog conversion to the complex baseband OFDM signal as [17] equation (4)

$$s(t) = \frac{1}{\sqrt{N}} \sum_{k=0}^{N-1} s_k i e^{j2\pi kt/T_s}, 0 < t < T_s \quad (4)$$

Where  $N$  is the number of subcarriers, and  $T_s$  is the active symbol interval. The time domain received signal after down conversion, analog-to-digital conversion, and perfect synchronization can be expressed as equation (5)

$$r(k) = s(k) + w(k) + i(k), k = 0, 1, \dots, N-1 \quad (5)$$

Where,  $s(k) = s(\frac{kTs}{N})$ ,  $w(k)$  is the additive white Gaussian noise (AWGN), and  $i(k)$  is the impulsive noise ( $s(k)$ ,  $w(k)$  and  $i(k)$  are assumed to be mutually independent). Here, we assume that the impulsive noise can be modeled as a Bernoulli–Gaussian random process as shown in equation (6)

$$i_k = b_k g_k, k = 0, 1, \dots, N-1 \quad (6)$$

Where  $b_k$  is the Bernoulli process, i.e., an independent and identically distributed sequence of zeros and ones with probability  $P(b_k = 1) = p$ , and  $g_k$  is the complex zero-mean white Gaussian noise. We assume that the additive white Gaussian noise (AWGN) has variance  $\sigma_w^2 = \frac{1}{2} E[w_k^2]$  and the variance of the Gaussian component of the impulsive noise is  $\sigma_g^2 = \frac{1}{2} E[g_k^2]$ . Without loss of generality, we also assume that the OFDM signal power is normalized as  $\sigma_s^2 = \frac{1}{2} E[s_k^2] = 1$ . The noise term  $u_k$  can also be expressed in terms of the two-component mixture-Gaussian model, which is widely accepted and frequently used for performance analysis of various transmission schemes in an impulsive noise environment. As mentioned in the introduction, the analysis can also be extended to the general case of multi-component mixture-Gaussian distribution. In such a case, the analysis is essentially the same as the analysis of two component mixture Gaussian model. To reduce energy of the impulsive noise, the blanking nonlinearity can be applied to the received baseband signal  $r_k$  before the conventional OFDM demodulator as shown in equation (7)

$$y_k = \begin{cases} r_k, & \text{if } |r_k| < T \\ 0, & \text{otherwise} \end{cases}, k = 0, 1, \dots, N-1 \quad (7)$$

here  $T$  is the threshold value.

Nonlinearity reduces the effect of large received signal values, as these are assumed to be the result of impulsive noise. Finally, signal samples  $y_k$  are fed to a conventional DFT-based OFDM demodulator.

## 2.6 Impulsive noise cancellation in multicarrier transmission

A multicarrier or orthogonal frequency-division multiplexing (OFDM) system is a method of data modulation that has recently gained increased interest with the development of faster signal-processing components and technologies [31]. It is used in European digital audio broadcasting (DAB) [32], and in wireless environments such as digital broadcast television and mobile communication systems [32]. However, OFDM based on discrete multi tone (DMT) systems are also examined for broadband digital communications on the existing copper networks [33]. This technique has been proposed for high-rate and asymmetric digital subcarrier lines (HDSL, ADSL) [33], local area networks (Hiperlan2), etc. The main idea behind OFDM is to split the transmitted data sequence into parallel sequences of symbols. This structure has the particularity to enable a simple equalization scheme and to resist to multipath propagation channel. In fact, inter-symbol interference (ISI) can be avoided when a guard interval (GI) is implemented between each block of time-domain samples to be transmitted. However, some carriers can be strongly attenuated. It is then necessary to incorporate a powerful channel encoder, combined with frequency and time interleaving. In this way, close-coded bits are not likely to fall simultaneously in a spectral null [32]. However, some of these quoted applications suffer from impulsive noise, and then the performance of such systems is damaged. The impulsive noise is an additive disturbance that arises primarily from the switching electric equipment and as spectral properties; the defined pulse has a pole and infinite energy. Therefore, bursty or isolated errors are usually generated by an impulsive noise affecting consecutive symbols in the Viterbi decoder, because such a decoder relies on the past history of the symbol sequence. Thus, a powerful decoder is required for such applications that are robust against impulsive noise in order to minimize its impact. The impulsive noise model that is used in this paper is that given by Ghosh, and it will be described later in the paper. In order to implement a digital modulator, an oversampled version of the continuous signal is often computed. This amounts to appending consecutive null symbols to the block of symbols to be modulated. Therefore, the OFDM modulator can be seen as a real Reed–Solomon (RS) encoder [34], and then it can be used as some specific impulsive noise canceller, the structure of which is well suited to the nature of the problem (i.e., a single impulse shows up as a single error), rather than counting on the classical channel coder to solve the problem. Practically, both types of codes will have to cooperate, in order to process both Gaussian and impulsive noise. To cancel impulsive noise, Wolf, Redinbo

Wu [35], and Kumaresan had also used the Bose–Chaudhuri–Hocquengem (BCH) code in the complex or real field, and they have considered the effect of minor errors. Wolf suggested two methods to correct large errors. The first is based on the Fourier transform coding and is a voting scheme. This technique takes the discrete Fourier transform (DFT) of the received sequence and examines those frequency components that should be zeros for the original data sequence. That means any samples of the received samples can be used to estimate the transmitted samples. So there are possibilities. If there are small independent errors on each of the transmitted components, the vote of the “correct vector” yields a cluster of vectors rather than a single vector. This technique is impractical for large values of  $N$ . The second method is a slightly modified BCH decoding algorithm, and it is not effective for multiple errors. Marvasti showed in [36] that the problem of signal reconstruction from missing samples can be resolved by using a reconstruction algorithm similar to the RS decoding technique, based on the Fourier transform. He proposed an error-recovery technique for bursts (BERT) of real and complex samples that uses techniques similar to Peterson’s method for BCH decoding and Forney’s decoding. The BERT technique is found to be sensitive to background noise. Wu [35] defined a class of real-number linear block codes using the discrete cosine transform (DCT). Despite the non cyclic nature of the DCT codes, a set of modified syndromes can be defined, with which a modified BCH decoding algorithm can be performed. He supposed that the codeword is corrupted by a minor error vector due to the background noise, and by impulsive noise due to the channel noise. To correct impulsive noise, he used a modified Berlekamp–Massey algorithm and the Forney algorithm, which include a decision threshold. However, for our case, DFT is preferred over DCT due to its cyclic properties. Kumaresan used RS codes, in real or complex fields to correct bursty impulsive noise in the presence of minor errors in each component of the received vector. He devised several decoding strategies based on least-squares techniques and singular value decomposition to estimate the location and the number of impulsive errors. However, Kumaresan *et al.* have not suggested any method to control the malfunction of their proposed decoding algorithm. Redinbo presented in [37] a decoding procedure for real-number codes which are also constructed by imposing constraints in the DFT domain: consecutive zeros. He assumed that code words are corrupted by small levels of round off noise, and occasionally by a few large “impulsive noises.” The error-correcting algorithm is divided in two parts. The first is the large activity detection that determines if large excursions are present and estimates their locations.

The second part is the large error value estimation. To estimate the impulsive error locations, he used a modified Berlekamp–Massey algorithm. The final stage of this algorithm consists of testing the corrected outputs by recomputing syndromes and employing a threshold detector. Redinbo differs from the others by this protection subsystem, but the proposed threshold is only tuned by simulation. These quoted references consider that the transmitted sequences contain some consecutive zeros, but this assumption does not correspond to a practical case. In many cases, however, pilot tones are transmitted and are scattered among the information ones. We believe that no studies have been done in order to correct impulsive noise in this context (nonconsecutive zeros or pilots), and by using the properties of BCH codes in the complex or the real field. To correct impulsive noise in this case, the correction capacity should be defined. However, Hartmann and Tzeng observed that there exist many cyclic codes whose defining set of zeros contains more than one set of consecutive zeros, and they succeeded in improving the BCH bound. They extended the BCH bound to that case, but they did not give a general solution. In [39], we have used a special case of the Hartmann–Tzeng bound, by considering that the output of the OFDM modulator contains uniformly spaced pilot tones, the spacing being coprime with the length of the transmitted sequence. However, some additional flexibility would be very useful in many applications. To correct impulsive noise in the OFDM system, we have suggested using the similarity between RS codes in the complex field and the OFDM system, and then the properties of RS codes in the complex field are easily applied [36].

## **2.7 Bit-interleaved coded OFDM with iterative decoding in impulsive noise**

With potential results and recent developments, the existing power-grid network is on its way from migrating from a pure energy distribution network to a multipurpose medium delivering energy, voice, data, and digital telecommunications services to every site. Due to the obvious advantages of this migration, power-line communications (PLC) are currently the focus of intense research activities. The power-grid network, however, differs considerably in structure as well as physical properties from the conventional communications systems. Varying levels of impedance and attenuation due to electrical hardware configurations are frequent. Such variations and other sources of interference lead to rather hostile properties of a PLC system. Those interferences, referred to as manmade noise, have statistical characteristics that are much different from that of classical Gaussian interference and noise. Manmade noise is typically

impulsive. A relatively simple model that incorporates background noise and impulsive noise is suggested in and is known as Middleton's class- noise. This noise model corresponds to an independent and identically distributed discrete-time random process whose probability density function is an infinite weighted sum of Gaussian densities, with decreasing weights and increasing variance for the Gaussian densities [39]. Middleton's classnoise model has been used widely in the performance analysis of PLC systems [40]. For uncoded systems (i.e., systems that do not implement error-control coding), the work in considers M-ary quadrature amplitude modulation (QAM) and designs optimum and suboptimum receivers for it. It is shown in that using the receiver properly designed for impulsive noise can significantly improve the error performance of PLC systems. More recently, the use of the orthogonal frequency-division multiplexing (OFDM) technique to combat impulsive noise has also received strong interest [41, 42]. The basic principle behind OFDM is to use a properly chosen linear transform at the transmitter and its inverse transform at the receiver. The transmitted signal passes both transforms and is therefore unaffected, whereas the impulsive noise passes the receiver's transform only. The energy of individual impulses is therefore dispersed (or smeared) over the increased symbol duration [43, 30]. In this way, the error floor that is typical for un-coded transmission over impulsive noise channels [40] is partially eliminated. When the number of subcarriers used in OFDM is sufficiently large, the transformation at the OFDM receiver essentially converts impulsive noise to Gaussian noise (due to the central-limit theorem) and a detector designed for an additive white Gaussian noise (AWGN) channel is generally applied to demodulate the transmitted symbols over each subcarrier. Although such implementation of OFDM in the impulsive noise environment is simple, it is by no means optimal. In fact, it can perform poorer than the single-carrier system with a properly designed receiver. This is because converting impulsive noise to Gaussian noise destroys the high structure of the impulsive noise and the detector optimally designed for Gaussian noise does not make use of it. Due to the aforementioned disadvantage, a more advanced and efficient receiver based on iterative processing is recently proposed in [41] for OFDM in an impulsive noise environment. In particular, the iterative receiver in consists of two information exchanging estimators, one in the "codeword" domain and one in the "information" domain. Such iterative decoding of the OFDM is shown in [41] to perform very close to the performance of an equivalent system over an AWGN channel.

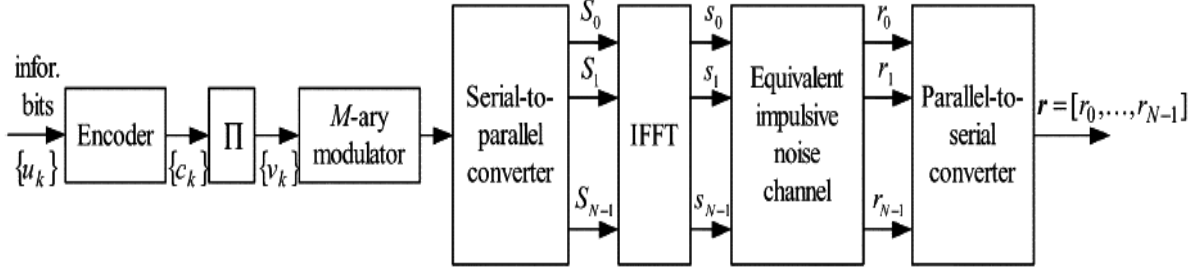

**Figure 10 Simplified block diagram of a bit interleaved coded OFDM system**

It is also well known that error performance of a communications system can be further improved by the use of error-control coding. Applying powerful turbo codes [44] to combat impulsive noise is investigated in where the authors also design an appropriate turbo receiver for an additive class noise (AWAN) channel. Motivated by the recent successes of BICM with iterative decoding (BICM-ID) over both AWGN and fading channels [45], the work in considers BICM-ID for an AWAN channel. It is demonstrated in that with the proper design of the soft-input soft-output (SISO) demodulator and appropriate constellation mapping, the use of BICM-ID can greatly improve the error performance and spectral efficiency of the PLC systems. Given the effectiveness of OFDM with iterative decoding for uncoded systems in [41] and BICM-ID for coded systems in, [46], it is natural to combine these techniques in one system. This is precisely the main proposal of this paper and the system under consideration shall be referred to as bit-interleaved coded OFDM with iterative decoding (BI-COFDM-ID). Here, the term “iterative decoding” refers to the fact that information exchange is carried out between the channel decoder and the OFDM demodulator, while the latter is an iterative block itself as described in [41].

### 2.7.1 System model

Figure 10 highlights the transmitter side of a bit-interleaved coded OFDM system. The information bits are first encoded by a convolutional code to produce a coded sequence. The coded sequence is then interleaved by the random interleaver. The interleaved sequence is mapped by the M-ary modulator into a symbol sequence. This symbol sequence is then passed through a serial-to-parallel converter, whose output is grouped into sets of N symbols  $\{S_0, S_1, S_2, \dots, S_{N-1}\}$  each, where  $s_k$  belongs to the M-ary constellation. Here, N is the number of

subcarriers employed in OFDM and the symbol  $s_k$  is transmitted over the  $k$ th subcarrier. In order to generate the transmitted signal, an inverse discrete Fourier transform (IDFT) is performed on  $N$  symbols. Typically,  $N$  is chosen to be a power of 2 and the IDFT can be efficiently implemented using the inverse fast Fourier transform (IFFT) algorithm. The IFFT yields the OFDM symbol consisting of sequence  $\{s_0, s_1, s_2, s_3, \dots, s_{N-1}\}$  of Length  $N$ , where  $(s_k)$  is given by equation (8)

$$s_k = \frac{1}{\sqrt{N}} \sum_{i=0}^{N-1} s_i e^{j2\pi ki/N}, 0 < k < N-1 \quad (8)$$

Assuming perfect synchronization and timing, the received symbols at the receiver are given by equation (9)

$$r_k = s_k + i_k + g_k, 0 < k < N-1 \quad (9)$$

Note that the impulsive noise is separated into two components:  $i_k$  accounts for impulsive noise and  $g_k$  represents Gaussian noise. In particular,  $g_k$ 's are i.i.d. circularly symmetric complex Gaussian random variables with variance,  $\sigma g^2$  whose probability density function (pdf) is given by equation (10)

$$P_g(x) = \frac{1}{2\pi\sigma g^2} \exp\left(-\frac{|x|^2}{2\sigma g^2}\right) \quad (10)$$

The impulsive noise variables  $i_k$ 's are also i.i.d. with variance,  $\sigma i^2$ . Their pdf is given by Middleton's class- model as shown in equation (11)

$$P_i(x) = e^{-A} \delta(x) \sum_{m=1}^{\infty} e^{-A} \frac{A^m}{m!} \frac{1}{2\pi\sigma m^2} \left(-\frac{|x|^2}{2\sigma m^2}\right) \quad (11)$$

with  $\sigma m^2 = \sigma i^2 m/A$  and  $\delta(\cdot)$  as the Dirac delta function. The parameter  $A$  is called the impulsive index. For small  $A$  (e.g.  $A=0.1$ ), the noise is highly structured since only  $1-e^{-A} \approx 9.5\%$  of the samples are hit by impulses. Also for convenience, define  $\Gamma = \sigma g^2 / \sigma i^2$  as the

Gaussian-to-impulsive noise power ratio. At the receiver, the problem of decoding the received vector  $r = [r_0, r_1, \dots, r_{N-1}]$  arises.

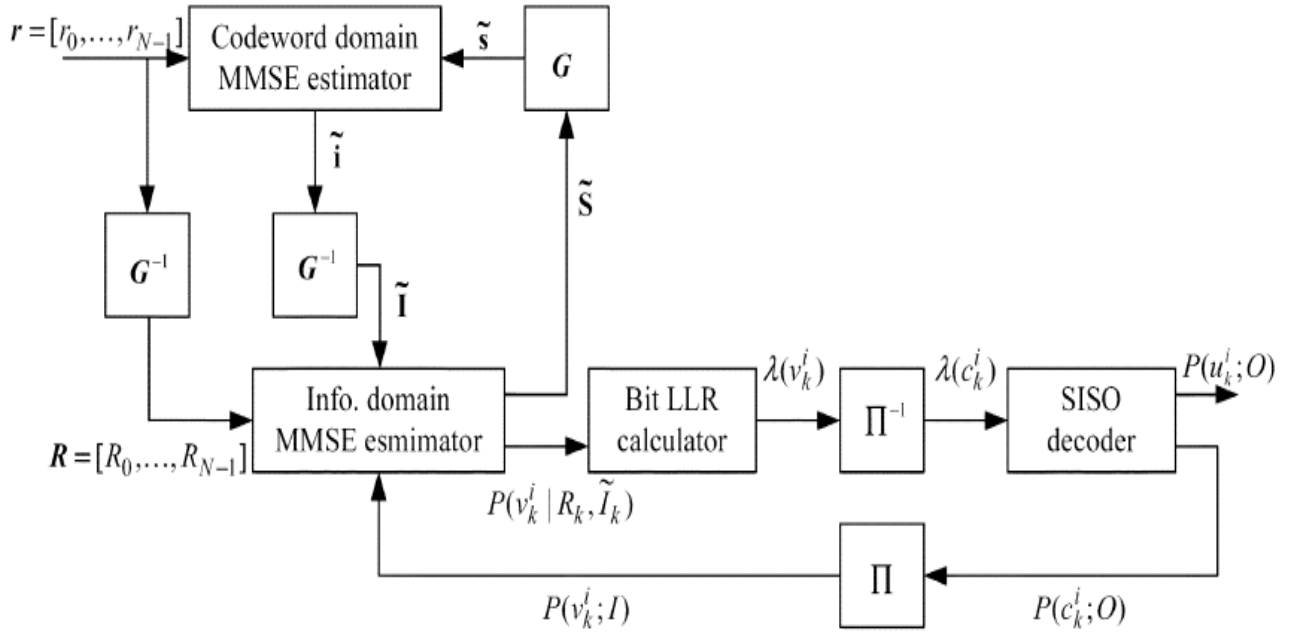

**Figure 11 Block diagram of the proposed iterative receiver for bit interleaved coded OFDM**

One can try to implement the maximum-likelihood (ML) decoder to minimize the probability of decoding error. However, such an optimum receiver is very complicated due to the presence of the random inter-leaver. To overcome this problem, this paper proposes a novel suboptimum iterative receiver as illustrated in Figure 11.

---

## BASIC OFDM SYSTEM MODEL FOR COMMUNICATION

### 3.1 Understanding an OFDM transmission

The principles of multicarrier modulation have been in existence for several decades. However, in recent years these techniques have quickly moved out of textbooks and into practice in modern communications systems in the form of orthogonal frequency division multiplexing (OFDM). OFDM is a special form of multicarrier modulation technique which is used to generate waveforms that are mutually orthogonal and then distributes the data over a large number of carriers that are spaced apart at precise frequencies. This spacing provides the "orthogonality" in this technique which prevents the demodulators from seeing frequencies other than their own. In an OFDM scheme, a large number of orthogonal, overlapping, narrow band subcarriers are transmitted in parallel. These carriers divide the available transmission bandwidth. The separation of the subcarriers is such that there is a very compact spectral utilization. With OFDM, it is possible to have overlapping sub channels in the frequency domain Figure 12, thus increasing the transmission rate.

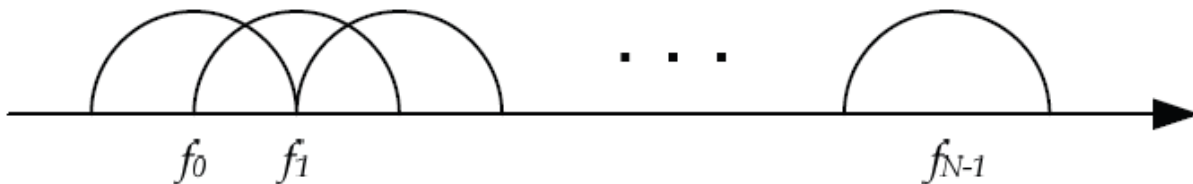
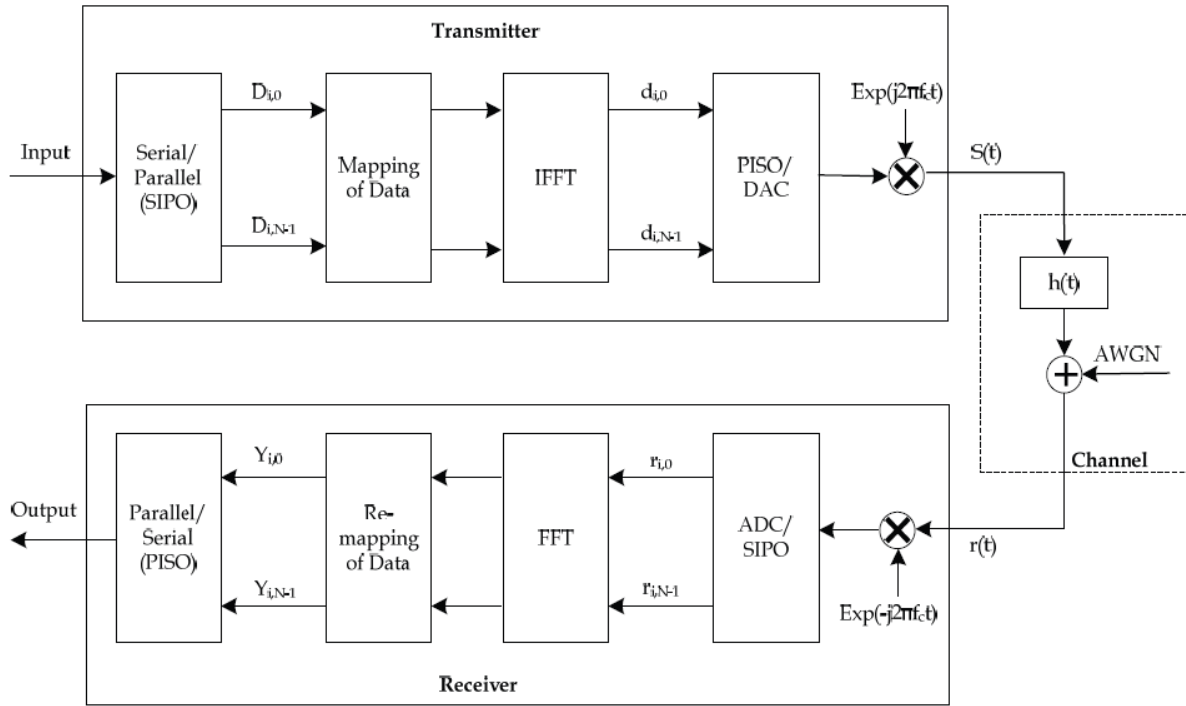

**Figure 12 Power spectrum of the transmitted signal.**

In order to avoid a large number of modulators and filters at the transmitter and complementary filters and demodulators at the receiver, it is desirable to be able to use modern digital signal processing techniques, such as fast Fourier transform (FFT). OFDM is a promising candidate for achieving high data rates in mobile environment because of its multicarrier modulation technique and ability to convert a frequency selective fading channel into several nearly flat fading channels.

### 3.1.1 OFDM system

Figure 13 shows the block diagram of a typical OFDM system. The transmitter section converts digital data to be transmitted, into a mapping of subcarrier amplitude and phase. It then transforms this spectral representation of the data into the time domain using an inverse discrete Fourier transform (IDFT). The inverse fast Fourier transform (IFFT) performs the same operations as an IDFT, except that it is much more computationally efficient, and so is used in all practical systems. In order to transmit the OFDM signal the calculated time domain signal is then mixed up to the required frequency. The receiver performs the reverse operation of the transmitter, mixing the RF signal to base band for processing, then using a fast Fourier Transform (FFT) to analyze the signal in the frequency domain. The amplitude and phase of the subcarriers is then picked out and converted back to digital data. The IFFT and the FFT are complementary functions and the most appropriate term depends on whether the signal is being received or generated. In cases where the signal is independent of this distinction then the term FFT and IFFT is used interchangeably. The high data rate serial input bit stream is fed into serial to parallel converter to get low data rate output parallel bit stream. Input bit stream is taken as binary data. The low data rate parallel bit stream is modulated in Signal Mapper. Modulation can be BPSK, QPSK, QAM, etc. The modulated data are served as input to inverse fast Fourier transform so that each subcarrier is assigned with a specific frequency. The frequencies selected are orthogonal frequencies. In this block, orthogonality in subcarriers is introduced. In IFFT, the frequency domain OFDM symbols are converted into time domain OFDM symbols. Guard interval is introduced in each OFDM symbol to eliminate inter symbol interference (ISI). All the OFDM symbols are taken as input to parallel to serial data. These OFDM symbols constitute a frame. A number of frames can be regarded as one OFDM signal. This OFDM signal is allowed to pass through digital to analog converter (DAC). In DAC the OFDM signal is fed to RF power amplifier for transmission. Then the signal is allowed to pass through additive white Gaussian noise channel (AWGN channel). At the receiver part, the received OFDM signal is fed to analog to digital converter (ADC) and is taken as input to serial to parallel converter. In these parallel OFDM symbols, Guard interval is removed and it is allowed to pass through Fast Fourier transform. Here the time domain OFDM symbols are converted into frequency domain. After this, it is fed into Signal De-mapper for demodulation purpose. And finally the low data rate parallel bit stream is converted into high data rate serial bit stream which is in form of binary.



**Figure 13 OFDM system implementation**

### 3.2 Cyclic prefix in orthogonal frequency division multiplexing

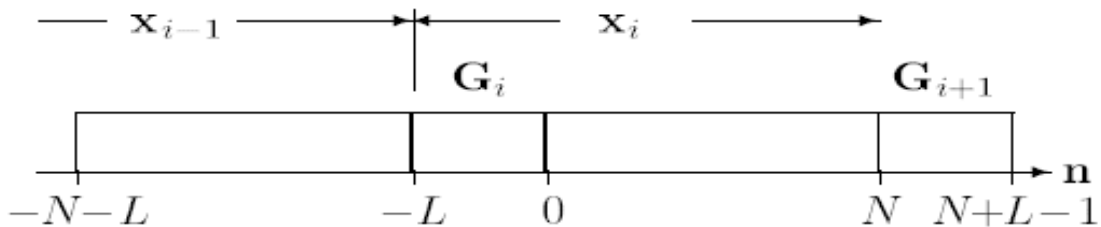
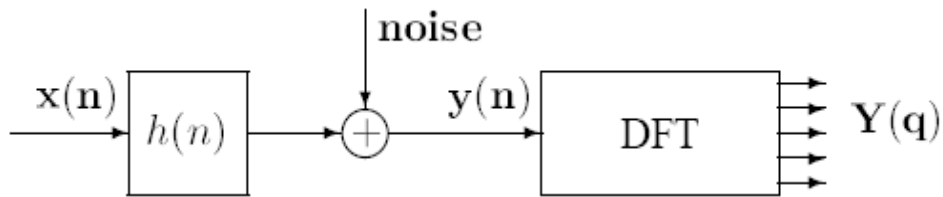

**Figure 14 Symbol structure.**

The cyclic prefix removes the inter symbol interference (ISI) and inter-carrier interference (ICI). The introduction of the cyclic prefix of length, see Figure.14, gives a constant capacity loss, since the channel does no longer carry data for short periods of time. As such, one would like to minimize the length of the cyclic prefix, preferably maintaining performance. Common wisdom is to choose the cyclic prefix to be of roughly the same length as the channel (or system) impulse response, thus eliminating ISI and ICI. It is also well established that, if the tail of the impulse response contains only very little energy, it

has little impact and can be considered zero allowing a shorter cyclic prefix. We show that, furthermore, the ISI and ICI can be spectrally concentrated and sometimes have limited or even zero impact on performance. Although this is not completely unknown among designers of DMT digital subscriber loop (DSL) systems, it has rarely been given a thorough analysis. Our attempt here is to provide an intuitive and immediate understanding of the mechanisms involved.

### 3.2.1 Signal model and interference calculation



**Figure 15 Signal Model**

The interference that we are studying consists of two parts: the inter symbol interference (ISI) and the inter carrier interference (ICI). We start with analyzing the ISI, which can be derived in a more intuitive fashion. We will also see that the ICI is of very similar structure, and can be described with the same mathematics under our present assumptions. Consider the transmission of symbols  $x_i(\mathbf{n})$  through a channel with the impulse response  $\mathbf{h}(\mathbf{n})$  of length  $L_h$ . We extend our notations with an index  $i$  on the input sequence  $x_i(\mathbf{n})$  as we need to distinguish between the input corresponding to the present symbol  $y_i(\mathbf{n})$ , which gives rise to the ICI, and the previous data  $x_{i-1}(\mathbf{n})$  which causes the ISI. The signal  $x(\mathbf{n})$  is assumed to be zero mean with a variance of  $\sigma_x^2$  and  $x(L+1), x(L+2), \dots, x(L_h-1)$  are assumed to be pair wise uncorrelated. The received signal, which is to be processed by the FFT (12)

$$y_i(n) = h(n) * x(n) = \sum_{v=0}^{L_h-1} h(v)x(n-v) \quad (12)$$

where  $x(n)$  denotes the concatenation of all  $x_i(\mathbf{n})$  up to the present symbol. A part of this signal will then be ISI from the previous symbol. Figure 16 illustrates the tails of the impulse response

that are not covered by the cyclic prefix. Note that in contrast to Figure 15 not only the guard interval but also its counterpart at the end of the frame is highlighted (hatched) and labeled with **G**. The ISI that affects a symbol  $i$  from a symbol  $i-1$  is shown in equation (13)

$$y_{ISI}(n) = \sum_{v=L+1+n}^{L_n-1} h(v)x(n-v), \text{ with } 0 \leq n \leq L_n - L - 2 \quad (13)$$

In (13), we actually used the concatenated symbols in order to simplify the description

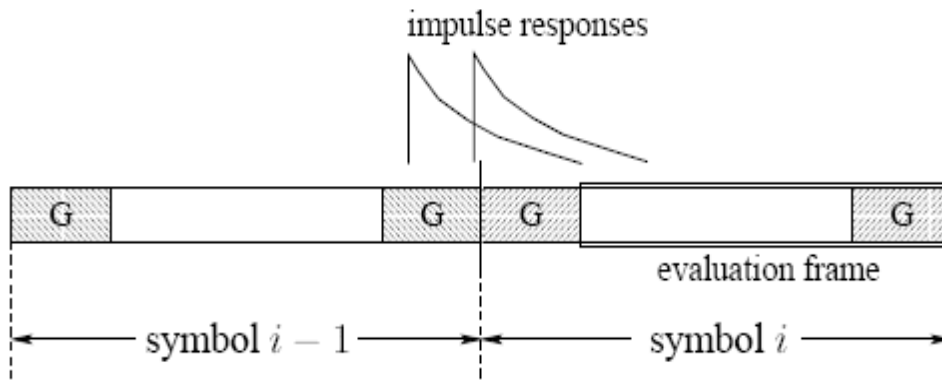

**Figure 16 ISI from symbol i-1.**

### 3.3 BPSK BER with OFDM modulation

OFDM technique is a multi-carrier transmission technique, which is being recognized as an excellent method for high-speed bidirectional wireless data communication. The prime idea is that all queuing data in buffer are uniformly allocated on small sub-carriers. OFDM efficiently squeezes multiple modulated carriers tightly together reducing the required bandwidth but keeping the modulated signals orthogonal so that they do not interfere with each other. OFDM that is highly efficient technique shows favorable properties such as robustness to channel fading and inter symbol interference (ISI) and is more immune to noise. OFDM system is capable of mitigating a frequency selective fading channel to a set of parallel flat fading channels, which need relatively simple processes for channel equalization.

Rayleigh and Rician fading distributions in frequency selective fading channels have already been deployed and studied in depth for OFDM systems. Various channel estimation and diversity schemes have been proposed in literature to enhance the error performance under Rayleigh and

Rician fading channel [47]. Nakagami-m fading distribution is another useful and important model to characterize the fading channel [48]. Kang et al modeled the OFDM- BPSK system with frequency selective fading channel. Zheng et al further enhanced the work by presenting asymptotic BER performance of OFDM system in frequency selective Nakagami-m channel. Here the accurate error performance of OFDM systems is analyzed on basis of number of channel taps in Nakagami-m fading environment.

OFDM systems have gained an equivalent attention with flat fading environment. In [49], present the method of channel estimation and carrier frequency offset to design an OFDM receiver in flat fading environment. The influence of Gaussian and flat Rayleigh fading channel on the PAPR of MIMO-OFDM pass band signals at the receiver-side have been presented in [50]. Another versatile wireless channel model, which can generalize the commonly used models for multipath fading and shadowing, is the two-parameter generalized gamma model. It includes multipath fading models such as Rayleigh, Nakagami-m, and Weibull as special cases and lognormal shadowing model as the limiting case. The performance of DS-CDMA in the frequency selective time non-selective multipath Generalized Gamma fading channels has already been investigated. However, performance measures such as the amount of fading, average bit error rate, and signal outage for generalized gamma fading channel has been presented in [51]

### 3.3.1 Model description

A Complex base band OFDM signal with N subcarriers is expressed as equation (14)

$$s(t) = \sum_{k=0}^{N-1} D_k e^{j2\pi f_0 k t}, 0 \leq t \leq T \quad (14)$$

For each OFDM symbol, the modulated data sequences are denoted by  $D(0), D(1), \dots, D(N-1)$ . Here,  $f_0$  denote the sub-carriers spacing and is set to  $f_0 = \frac{1}{T}$  the condition of orthogonality. After IFFT, the time-domain OFDM signal can be expressed as equation (15)

$$\begin{aligned} s(t) &= \frac{1}{N} \sum_{k=0}^{N-1} D_k e^{j2\pi f_0 k t} \\ &= \text{IFFT}(D_0, D_1, \dots, D_{N-1}) \end{aligned} \quad (15)$$

After IFFT, the modulated signal is up-converted to carrier frequency  $f_c$  and then the following signal is produced and transmitted through channel as in equation (16)

$$x(t) = \text{Re} \left\{ \sum_{k=0}^{N-1} D_k e^{j2\pi k(f_0 + f_c)t} \right\}, 0 \leq t \leq T \quad (16)$$

$x(t)$  Represents the final OFDM signal in which sub-carriers shall undergo a flat fading channel.

### 3.3.2 Results and discussions

In this section, we have presented the simulation results by implementing two modulation formats for OFDM to get threshold value of fading parameter  $m$ . Figure 17 indicates the BER versus SNR for OFDM-BPSK with different values of fading parameter  $m$ . It is clear from section 3, that at  $m=1$ , Nakagami- $m$  fading corresponds to Rayleigh fading. So, the results for the same have been achieved through simulations. Nakagami- $m$  PDF with parameter  $m < 1$  models worse than Rayleigh conditions and fading becomes more severe. So, the value of  $m$  is increased and as a result the BER starts reducing and value of  $10^{-4}$  is reported at  $m = 1.4, 1.5$  and  $2$ . Further, if we increase  $m$ , no reduction in BER has been reported rather it starts increasing. So this put a limit to increase the value of  $m$  beyond the certain value. The optimal value of  $m$  is achieved to be  $1.4$ , to estimate the fading channel. However, it is commonly believed that larger the value of  $m$  will lead to smaller value of error rates, but it is not found to be same. This interesting fact about the threshold value of fading parameter has also been reported for frequency selective fading Nakagami- $m$ channel Zheng.

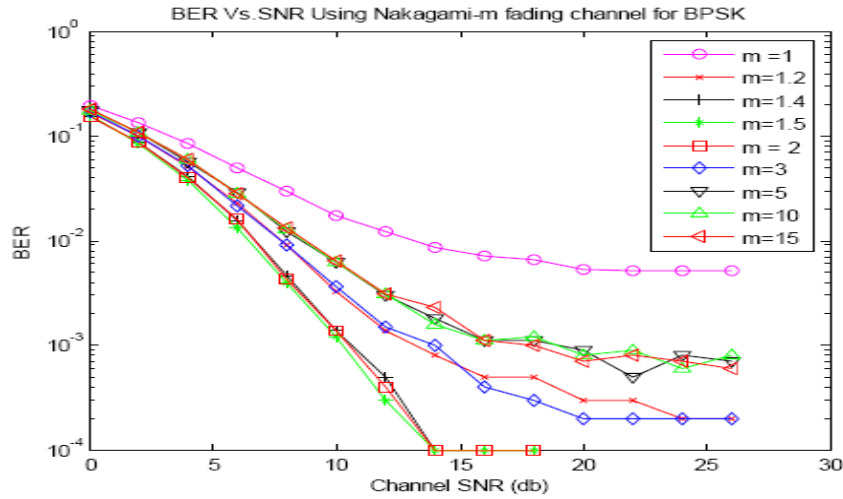

**Figure 17 BER VS SNR for OFDM-BPSK system.**

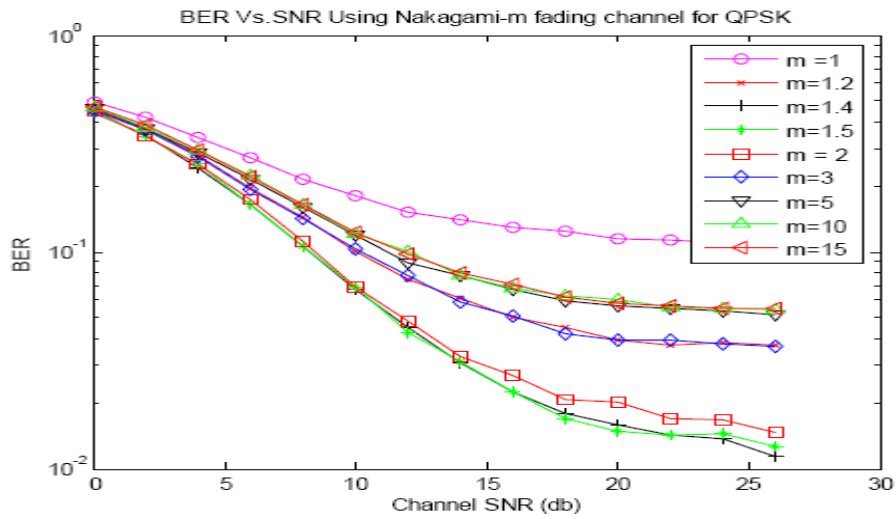

**Figure 18 BER VS SNR for OFDM-QPSK system.**

We have further analyzed OFDM system using QPSK as shown in Figure 18. Results obtained from simulations for OFDM-QPSK systems are similar in nature to that of OFDM-BPSK system. BER starts decreasing with increasing value of  $m$ . It is very well depicted from graph the threshold value of  $m=1.4$  is achieved with BER value of  $10^{-2}$ . If value of  $m$  is further increased, BER starts increasing. In both the graphs, the BER at value of  $m=1$  reports to Rayleigh fading error rate for OFDM systems, which has already been reported in literature. Finally, it is

concluded that BER performance of OFDM system in Nakagami-m channel degrades if we increase m beyond the certain threshold value.

### **3.4 BER for BPSK in OFDM with Rayleigh multipath channel**

We have a simple and efficient simulation method for MIMO-OFDM system with channel equalization. BPSK modulation is used to detect the behavior of the Rayleigh fading channel in presence of additive white Gaussian noise and then its performance is evaluated. Obtained result is then compared with adding MLSE equalizer. Here we have the addition of equalizer reduces the BER (Bit Error Rate) and the channel output becomes more pronounced. Though the total channel is a frequency selective channel, the channel experienced by each subcarrier in an OFDM system is a flat fading channel with each subcarrier getting independent Rayleigh fading.

The rising demand of multimedia services and the development of Internet related contents lead to increasing curiosity to high speed communications. In the ceaseless search for increased capacity in a wireless communication channel it has been shown that by using MIMO (Multiple Input Multiple Output) system architecture it is possible to increase that capacity considerably. The combination MIMO-OFDM is very likely and beneficial since OFDM enables support of more antennas and larger bandwidths since it simplifies equalization in MIMO systems. Usually fading is considered as a problem in wireless communication but MIMO channels uses the fading to increase the capacity of entire system. Fading of the signal can be mitigated by different diversity techniques.

#### **3.4.1 Overview of MIMO-OFDM system**

The MIMO system transmits different signals from each transmit element so that the receiving antenna array receives a superposition of all the transmitted signals. All signals are transmitted from all elements once and the receiver solves a linear equation system to demodulate the message. Multiplexing (MIMO-OFDM) system is an effective solution to improve communication quality, performance, capacity, and transmission rate. MIMO-OFDM is under intensive investigation by researchers. A block diagram is shown in Figure 19

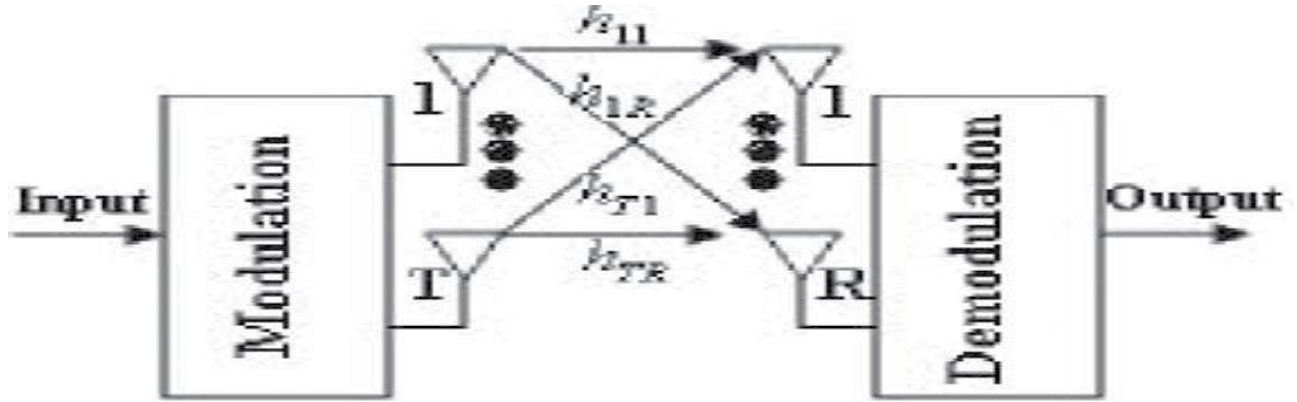

**Figure 19 Block diagram MIMO.**

We consider the system where the transmitter has  $n_t$  antennas and the receiver has  $n_r$  antennas. Let  $h_{m,n}$  be a complex number corresponding to the channel gain between transmit antenna  $n$  and the receive antenna  $m$ . If at a certain time instant complex signals  $\{x_1, x_2, \dots, x_{n_t}\}$  transmitted via  $n_t$  the antennas, the received signals at antenna  $m$  can be expressed as equation (17)

$$y_m = \sum_{n=1}^{n_t} h_{m,n} x_n + e_m \quad (17)$$

Where  $e_m$  is a noise Signal. This relation is easily expressed in a matrix structure. Let  $x$  and  $y$  be  $n_t$  and  $n_r$  vectors containing the transmitter and receiver data, respectively. Define the following  $n_t \times n_r$  channel gain matrix.

$$H = \begin{pmatrix} h_{11} & \dots & h_{1,n_t} \\ \vdots & \ddots & \vdots \\ h_{n_r,1} & \dots & h_{n_r,n_t} \end{pmatrix} \quad (18)$$

Then we have,

$$y = HX + e \quad (19)$$

where  $e = [e_1 \dots \dots \dots e_{n_r}]^T$  is a vector of noise samples.

Key tool for increasing the transmission rate with several transmitting antennas system consist of transmitting more independent streams, or layers of data from all available transmit antennas, all together. In more precise terms, if we have a system with  $P$  transmit antennas, we can transmit simultaneously,  $P_t$  independent symbols one from each  $t$  transmit antenna. At the receiver, we can get, at any time instant  $P_r$  observations one from each receive antenna. Therefore at any time instant, we have a system of  $P_r$  observations in  $P_t$  unknowns.

Figure.20 shows the bit error rate (BER) of MIMO- OFDM system, with two transmits and one receive antenna over a Rayleigh fading with additive white Gaussian noise (AWGN) channel. It is noticeable that the bit error rate reduces as the signal to noise ratio increases. After zero on x-axis, this BER decreases rapidly with  $E_b/N_0$ . By using MLSE equalizer, it performs much better

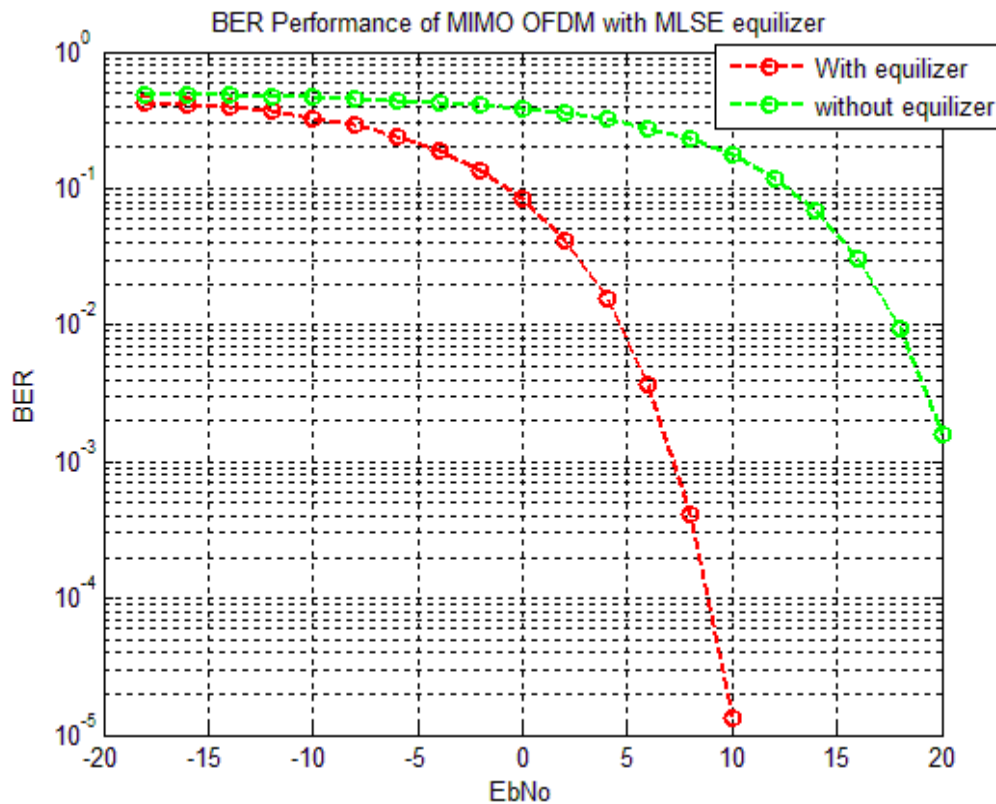

**Figure 20 BER performance of MIMO-OFDM.**

So, the performance of MIMO OFDM is characterized with low complexity. The Rayleigh distribution assumes that there are a sufficiently large number of equal power multipath

components with different and independent phase. On the basis of above figure we can say that the structure has low bit error rate when MLSE equalizer is used.

### 3.5 Inter carrier interference (ICI) in OFDM system

Orthogonal frequency division multiplexing (OFDM) is a promising technology for broadband transmission. It has been widely used for wireless applications. In OFDM systems, a serial data stream is split into parallel streams that modulate a group of orthogonal sub-carriers. Due to its multicarrier feature, OFDM systems are more sensitive than single-carrier systems to frequency synchronization errors. A well known problem of OFDM, however, is its sensitivity to frequency offset between the transmitted and received signals, which may be caused by Doppler shift in the channel, or by the difference between the transmitter and receiver local oscillator frequencies. This carrier frequency offset causes loss of orthogonality between sub-carriers and the signals transmitted on each carrier are not independent of each other, leading to inter-carrier interference (ICI) as in Researchers have proposed various methods to combat the ICI in OFDM systems. The existing approaches that have been developed to reduce ICI can be categorized as frequency-domain equalization, time-domain windowing and the ICI self-cancellation (SC) scheme.

#### 3.5.1 OFDM system description

In an OFDM system, the input bit stream is multiplexed into  $N$  symbol streams, each with symbol period  $T$ , and each symbol stream is used to modulate parallel, synchronous sub-carriers. The sub-carriers are spaced by  $1/NTS$  in frequency, thus they are orthogonal over the interval  $(0, TS)$ . A typical discrete-time baseband OFDM transceiver system is shown in Figure 21. First, a serial-to-parallel (S/P) converter groups the stream of input bits from the source encoder into groups of  $\log_2 M$  bits, where  $M$  is the alphabet of size of the digital modulation scheme employed on each sub-carrier. A total of  $N$  such symbols,  $X_m$ , are created. Then, the  $N$  symbols are mapped to bins of an inverse fast Fourier transform (IFFT). These IFFT bins correspond to the orthogonal sub-carriers in the OFDM symbol. Therefore, the OFDM symbol can be expressed as equation (20)

$$x(n) = \frac{1}{N} \sum_{m=0}^{N-1} X_m e^{\frac{j2\pi mn}{N}} \quad (20)$$

Where the  $X_m$ 's are the baseband symbols on each sub-carrier. The digital-to-analog (D/A) converter then creates an analog time-domain signal which is transmitted through the channel. At the receiver, the signal is converted back to a discrete  $N$  point sequence  $y(n)$ , corresponding to each sub-carrier. This discrete signal is demodulated using an  $N$ -point fast Fourier transform (FFT) operation at the receiver. The demodulated symbol stream is given by equation (21)

$$Y(m) = \sum_{n=0}^{N-1} y(n)e^{-\frac{j2\pi mn}{N}} + W(m) \quad (21)$$

Where,  $W(m)$  corresponds to the FFT of the samples of  $w(n)$ , which is the Additive White Gaussian Noise (AWGN) introduced in the channel. The high speed data rates for OFDM are accomplished by the simultaneous transmission of data at a lower rate on each of the orthogonal sub-carriers. Because of the low data rate transmission, distortion in the received signal induced by multi-path delay in the channel is not as significant as compared to single-carrier high-data rate systems. Multipath distortion can also cause inter-symbol interference (ISI) where adjacent symbols overlap with each other. This is prevented in OFDM by the insertion of a cyclic prefix between successive OFDM symbols. This cyclic prefix is discarded at the receiver to cancel out ISI. It is due to the robustness of OFDM to ISI and multipath distortion that it has been considered for various wireless applications and standards.

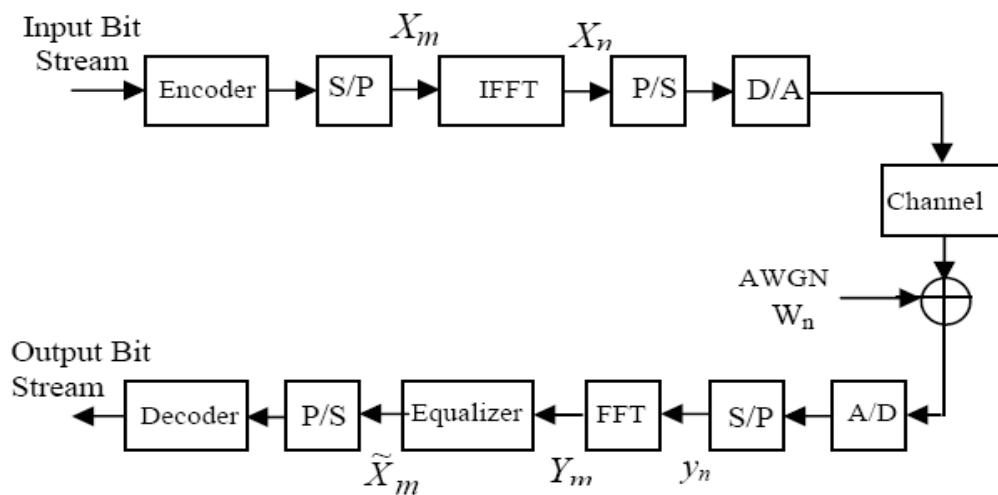

**Figure 21 Baseband OFDM transceiver system.**

### 3.5.2 Analysis of inter-carrier interference

The main disadvantage of OFDM, however, is its susceptibility to small differences in frequency at the transmitter and receiver, normally referred to as frequency offset. This frequency offset can be caused by Doppler shift due to relative motion between the transmitter and receiver, or by differences between the frequencies of the local oscillators at the transmitter and receiver. In this project, the frequency offset is modeled as a multiplicative factor introduced in the channel, as shown in Figure 22.

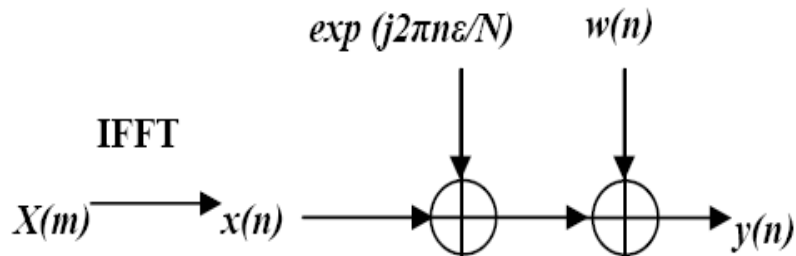

Figure 22 Frequency offset model.

The received signal is given by equation (22)

$$y(n) = x(n)e^{\frac{j2\pi n\epsilon}{N}} + w(n) \quad (22)$$

Where  $\epsilon$  is the normalized frequency offset, and is given by  $\Delta f N T_s$ .  $\Delta f$  is the frequency difference between the transmitted and received carrier frequencies and  $T_s$  is the subcarrier symbol period.  $w(n)$  is the AWGN introduced in the channel. The effect of this frequency offset on the received symbol stream can be understood by considering the received symbol  $y(k)$  on the  $K^{th}$  sub-carrier as given in equation (23)

$$y(k) = X(k)S(0) + \sum_{l=0, l \neq k}^{N-1} X(l)S(l-k) + n_k, k = 0, 1, 2, \dots, N-1 \quad (23)$$

Where  $N$  is the total number of sub-carriers,  $X(k)$  is the transmitted symbol for the  $k^{th}$  sub-carrier,  $n_k$  is the FFT of  $w(n)$ , and  $S(l - k)$  are the complex coefficients for the ICI components in the received signal. The ICI components are the components in the received signal. The ICI components are the interfering signals transmitted on sub-carriers other than the  $k^{th}$  sub-carrier. The complex coefficients are given by equation (24)

$$S(l - K) = \frac{\sin(\pi(l + \varepsilon - k))}{N \sin(\frac{\pi(l + \varepsilon - K)}{N})} \exp(j\pi(1 - \frac{1}{N})(l + \varepsilon - K)) \quad (24)$$

To analyze the effect of ICI on the received signal, we consider a system with  $N=16$  carriers. The Frequency offset values used are 0.2 and 0.4, and  $l$  is taken as 0, that is, we are analysing the signal received at the sub-carrier with index 0. The complex ICI coefficients  $S(l - k)$  are plotted for all sub-carrier indices in Figure.23. This figure gives an example of the  $S(l - k)$  when  $l=0$  and  $N=16$ . It is evident that as  $\varepsilon$  becomes larger, the desired part  $|S(0)|$  decreases and the undesired part  $|S(l-k)|$  increases.

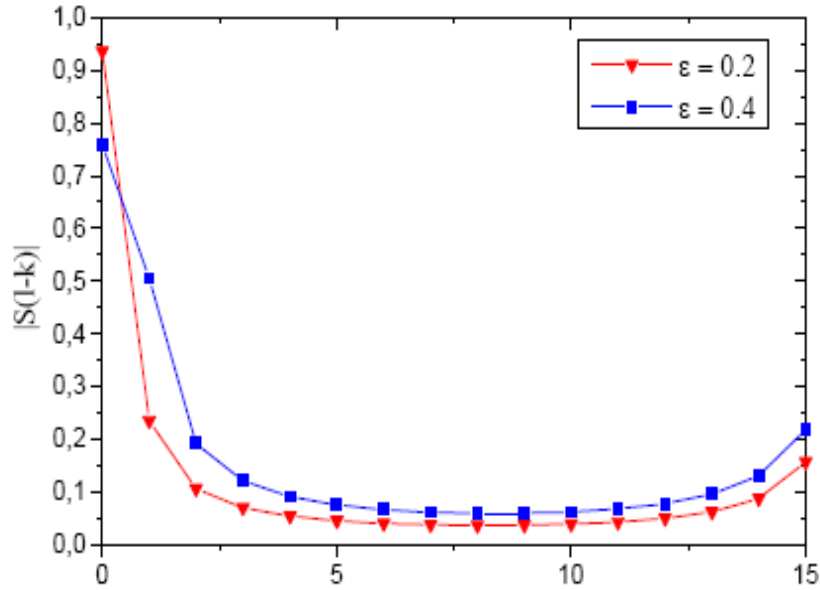

**Figure 23 ICI coefficients for N=16 carriers**

---

## NOISE BUCKET EFFECT

Impulse noise is a significant problem in some orthogonal frequency division multiplexing (OFDM) applications. It has been observed in practice that the degradation caused by impulse noise depends only on the total energy of the noise during each OFDM symbol, not on the structure of the noise. This ‘noise bucket’ effect is explained by showing that even for a small number of impulses per symbol the noise distribution at the input of the receiver decision device is close to Gaussian. This is because of the spreading effect of the discrete Fourier transform.

In OFDM, decisions about the transmitted data are based on the signals at the output of the receiver discrete Fourier transform (DFT). We show that even when the noise at the receiver is impulsive, the noise after the DFT is approximately Gaussian. This is a result of the spreading effect of the DFT. Thus irrespective of the detailed structure of the impulse noise, the error rate which is observed is approximately the same as the error rate that would result for Gaussian noise with the same total energy per symbol

### 4.1 Impulse noise and its effects in OFDM

Impulse noise can potentially affect a number of receiver functions. For example, it can cause the input amplifier to overload or disrupt the automatic gain control. These effects are not considered here, here only the effect of impulse noise on the baseband digital section of the receiver is considered.

The received time domain baseband OFDM signal is mathematically expressed as equation (25)

$$r(k) = x(k) = n(k) + i(k) \tag{25}$$

where  $x(k)$  is the wanted OFDM signal,  $n(k)$  is additive white Gaussian noise (AWGN) with zero mean and variance  $E\{|n(k)|^2\} = \sigma n^2$  and  $i(k)$  is the impulse noise. The statistical properties of  $i(k)$  depend on both the form of impulse noise at the receiver input and on the filtering properties of the receiver front end. A number of impulse noise models based on theoretical analysis or

experimental data have been presented in previous literature. However very recent research by the BBC, which measured a variety of impulse noise sources of practical importance in OFDM applications, concluded that impulse noise can be modeled as gated Gaussian noise.

The ‘noise bucket’ concept applies in quantifying the performance of OFDM impaired by impulse noise. The decision noise becomes approximately Gaussian even with a small number of impulse occurrences.

## **4.2 Impulsive noise suppression in OFDM based communication systems**

Orthogonal frequency division multiplexing (OFDM) is a technique used for terrestrial digital video broadcasting (DVB-T) and many other modern applications. The longer OFDM symbol duration provides an advantage in a presence of weak impulsive noise, because impulsive noise energy is spread among simultaneously transmitted OFDM sub-carriers. However, it has been recently recognized that this advantage turns into a disadvantage if the impulsive noise energy exceeds certain threshold. Here, the algorithm for impulsive noise suppression in OFDM receivers is proposed and investigated. Whereas traditional methods for impulsive noise suppression are implemented in a time domain before OFDM demodulation, proposed algorithm compensates impulsive noise in a frequency domain after OFDM demodulation and channel equalization. The method is applied to DVB-T and its performance is studied by means of simulation1.

Orthogonal Frequency Division Multiplexing (OFDM) is a multicarrier modulation scheme that can cope with high degree of multipath distortions. This technique has been used in digital audio broadcasting [52] and has been chosen for European digital terrestrial video broadcasting (DVB-T). In general, OFDM systems are less sensitive to impulsive interference than single-carrier systems. This is due to fact that the OFDM symbol has longer duration and impulsive noise energy is distributed among simultaneously transmitted OFDM sub-carriers. However, under certain circumstances impulsive noise can significantly affect performance of OFDM systems. For example, it has been recently noted that DVB-T system that uses 64-QAM (quadrature amplitude modulation) could be seriously affected by impulsive interference [53]. Traditional methods for impulsive noise suppression in multicarrier receivers are based on time domain signal processing before conventional OFDM demodulator [54]. These methods provide some

degree of protection against impulsive noise, but performance of traditional methods is still far away from theoretical bounds. Another group of methods exploits specific properties of OFDM signals. It is known fact that OFDM modulator with zero sub-carriers in several consecutive positions can be viewed as Reed-Solomon coder in a complex field. This can be used for impulsive noise compensation. The problem is that conventional error correction decoders cannot cope with the signal affected by both impulsive interference and white Gaussian noise. Recently, iterative algorithm for decoding complex number codes in impulsive noise channels was described and close relationship between OFDM and complex number codes was shown in [55]. Here, we present practical algorithm for impulsive noise suppression in OFDM receivers based on principles similar to [55]. Analysis of the algorithm and results of simulations demonstrating effectiveness of the algorithm in DVB-T system under various channel conditions are also presented.

#### 4.2.1 System model

First, let us introduce the model of the OFDM system and communication channel. In the OFDM transmitter set of information bits are first mapped into baseband symbols  $\{S_k\}$  using modulation schemes such as phase-shift-keying (PSK) or quadrature-amplitude-modulation (QAM). In every OFDM symbol interval symbols  $\{S_k\}$  are transformed by means of inverse discrete Fourier transform (IDFT) and digital-to-analog conversion to the baseband OFDM signal as equation (26)

$$s(t) = \sum_{k=0}^{N-1} S_k e^{j2\pi k \Delta f t}, 0 < t < T_s \quad (26)$$

where  $N$  is the number of sub-carriers,  $f$  is separation between adjacent sub-carriers, and  $T_s$  is the OFDM symbol interval. The received signal (in the time domain) after down conversion, analog-to-digital conversion, guard interval removing, and synchronization can be represented as equation (27)

$$r_k = \sum_{i=1}^L h_i S_{k-1} + W_k + u_k, k = 0, 1, \dots, N-1 \quad (27)$$

Where  $s(kT) = \sum_{l=0}^{L-1} h_l s(kT - lT)$ ,  $h_l$  is the channel impulse response,  $L$  is the length of channel impulse response,  $w_k$  is additive white Gaussian noise (AWGN), and  $u_k$  is the impulsive noise. Analytical characterization of impulsive noise is quite difficult task. Several analytical and empirical impulsive noise models were proposed in a literature in last twenty years [56]. Some of these models characterize impulsive noise from particular sources in certain conditions with high degree of accuracy. However, in many practical situations it is very difficult to predict statistical properties of impulsive interference.

On the other hand, impulsive noise from any source in any system has two common properties: Impulsive noise energy is concentrated into short periods. Impulsive noise energy is much higher than that of background (thermal) noise.

Here, we assume that impulsive noise sequence  $\{u_k\}$  can be characterized by these two properties. We also assume that impulsive noise duration is much shorter than active period of the OFDM symbol  $T_s$ .

### **4.3 Impulse noise mitigation for OFDM using decision directed noise estimation**

Here we describe a new technique for mitigating the effects of impulse noise in OFDM. An estimate is made of the noise component in each received input sample. The estimates are based on the transmitted data. No pilot tones are required. When the estimate is large enough to indicate that impulse noise is present in the sample, the estimated noise component is subtracted from the input sample before final demodulation. Estimates of the noise are obtained from preliminary decisions based on the noisy signal. The technique is effective because the energy from each noise impulse is spread across the received spectrum. The technique can also be applied to multicarrier CDMA.

Orthogonal frequency division multiplexing (OFDM) technology is used in many digital broadband communication systems. One of the advantages of OFDM compared to single carrier systems is that it is more resistant to the effects of impulse noise. However impulse noise can still cause significant problems in OFDM systems. The effects of impulse noise in multicarrier systems have previously been analyzed [61], and a number of techniques for mitigating the effect

of impulse noise have been described. One approach is to identify peaks in the received time domain signal and reduce these by either clipping or nulling the sample [57]. This is effective only for impulse noise which has peaks which are larger than the wanted OFDM signal. This will be true only in very extreme cases. In high signal to noise environments such as broadcast television, the impulse noise can be well above the background Gaussian noise, yet well below the OFDM signal. Several authors have used techniques that operate on the signal in the frequency domain [58, 27]. [58] Describe an iterative process in which information is exchanged between estimators operating in the time and frequency domains. The simulation results they present are for extreme cases with very large noise impulses. In impulses are detected in the frequency domain by identifying subcarriers with extreme values. In [58] the positions of noise impulses are identified using pilot tones. This allows the corrupted samples to be nullified but no estimate of the actual value of the noise is made.

We use a new technique for estimating and mitigating impulse noise in OFDM. Preliminary decisions are made about the transmitted data. Based on these an estimate of the noise is made. This is subtracted from the input signal before final demodulation. When the input noise is impulsive, the technique substantially reduces the noise power. The technique depends on the fact that the signal appears random in the time domain and highly structured in the discrete frequency domain whereas for the impulse noise the converse is true. The technique is analyzed by considering the decision process as a non-linearity operating on the noise and applying Bussgang's theorem. The technique is shown to significantly reduce the symbol error rate (SER), is applicable to systems that have already been standardized, and is well suited to digital signal processing (DSP) implementation.

#### 4.3.1 New impulse mitigation technique

Figure 24 above shows the block diagram of a receiver with the new mitigation technique. The received OFDM baseband signal samples are given by equation (28)

$$x(l) = r(l) + n_g(l) + n_i(l) = r(l) + n_t(l) \quad (28)$$

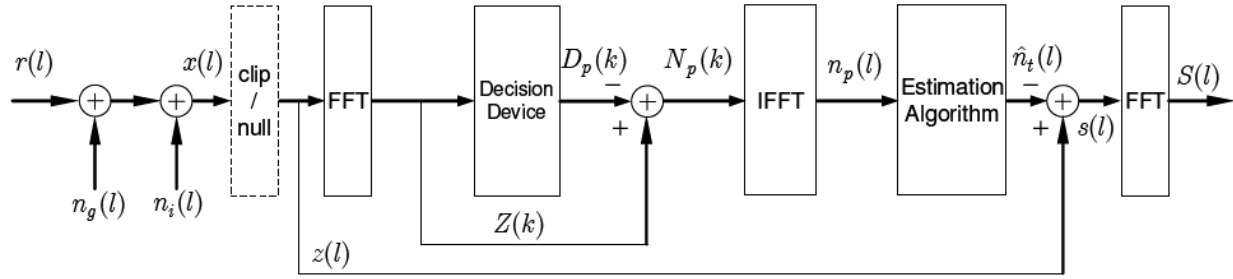

**Figure 24 Block diagram of receiver with impulse mitigation.**

Where  $r(l)$  is the wanted OFDM signal,  $n_g(l)$  is the Gaussian noise and  $n_i(l)$  is the impulse noise.  $n_t(l) = n_g(l) + n_i(l)$  is the total noise at the input. The samples  $x(l)$  are optionally passed through a non-linearity that clips or nulls large samples. The samples at the output of the non-linearity  $Z(l)$  are serial-to-parallel converted to form the vector of  $N$  complex samples that are input to the  $N$  point discrete Fourier transform (DFT). The output of the DFT is the  $N$ -point vector  $\mathbf{z}$ . Preliminary decisions; about the transmitted data are made based on  $Z(k)$ . The noise component of  $Z(k)$  is  $N_i(k)$ . The observed noise,  $N_p(k)$  is calculated using equation (29)

$$N_p(k) = Z(k) - \hat{D}_p(k) \quad (29)$$

Except for extreme cases, most of the received subcarriers are correctly decoded and the observed noise is exactly equal to the received noise in that subcarrier. In the cases where the subcarrier is incorrectly decoded, ‘decision noise’ will be added to the observed value.

OFDM is more resistant to the effects of impulse noise than single carrier systems because of the spreading effect of the receiver DFT operation. The energy of each impulse is spread evenly across all of the subcarriers in that symbol. When there is more than one impulse in a received symbol period  $T$ , the contributions combine linearly in each subcarrier. When there are enough impulses during  $T$  for the central limit theorem to apply,  $N_t(k)$  has a Gaussian distribution.

The vector  $N_p$  is then converted back into the discrete time domain using an inverse FFT to give the vector  $n_p$ , if there are no decision errors,  $n_p(l) = n_t(l)$ . However even in the presence of

decision errors contains some information about  $n_t(l)$ .  $n_p(l)$  is then input to an estimation device to generate an estimate  $\hat{n}_t(l)$  of the total input noise. This is subtracted from  $Z(l)$  to generate  $S(l)$ . The rest of the receiver is a standard OFDM receiver consisting of DFT etc. For the technique to be effective in reducing the overall bit error rate (BER) of the system,  $n_t(l)$  must be impulsive (not stationary Gaussian) and the estimation algorithm must be non-linear. If the estimation process is linear, it will appear to improve the received constellation as each point moves towards the value  $D_p(k)$ , but the points will move closer to both incorrect and correct decision points. However, the technique is very effective if non-linear processing is used and the noise is impulsive. This depends on the fact that for large values of  $n_t(l)$ ,  $n_p(l) \approx n_t(l)$

Fig.4.1 shows an optional clipping or nulling function operating on the received baseband samples. This reduces the effect of very large noise impulses that are above the envelope of the OFDM signal. However the simulations show that this improves the performance only in very extreme cases. The analysis here is for OFDM in a flat fading channel. However the technique can also be applied to OFDM in frequency selective fading channels and to multicarrier code division multiple access (MC-CDMA) systems. For a frequency selective channel a single tap equalizer must be placed before the decision device and the inverse of this equalizer between the decision device and the adder which outputs  $N_p(k)$ . For MC-CDMA the signal must be spread before the decision device and re spread before the adder. The key factor is that noise which is impulsive in the time domain must be spread out in the ‘decision’ domain.

### 4.3.2 Impulse noise models

A number of models for impulse noise have been presented. Some characterize only the probability density function of the amplitude of the noise, whereas others also consider the time correlation of impulse events. Very recent research by the BBC, which measured a variety of impulse noise sources, has shown that many of the impulse noise sources of practical importance in OFDM applications can be modeled as gated Gaussian noise.

Here, we use a particular form of gated Gaussian noise, where the noise is the sum of additive white Gaussian noise (AWGN) of variance  $\sigma_n^2$  and a second higher variance Gaussian noise component which lasts for a fraction,  $\mu$  of the time duration of each OFDM symbol and which

has variance  $\sigma_i^2$  during this time. (The variance is calculated over only  $\mu T$  not over  $T$ ). The total noise power is then  $\sigma^2 = \mu\sigma_i^2 + \sigma_n^2$ . Each of these variances is for the real and imaginary components taken separately. The impulsive samples are spread randomly throughout each OFDM symbol. The gated Gaussian model is used because it gives a good indication of the performance of OFDM systems. Here the critical factor is whether the BER for each symbol is above the threshold at which the error correcting coding will reduce the final BER to an acceptable level, rather than the BER averaged over the entire received signal. It also allows the length and power of the impulse noise to be varied in a way that makes clear the practical implications of the technique

#### **4.4 Performance comparison of ATSC 8-VSB and DVB-T COFDM transmission systems for digital television terrestrial broadcasting**

Digital Television Terrestrial Broadcasting (DTTB) has finally reached the implementation stage. DTTB services have been available in North America and Europe, since November 1998. Many countries have announced their choice of the DTTB system and implementation plan. There are two very different digital modulation techniques used in DTTB systems: the Trellis Coded 8-Level Vestigial Side-Band (8-VSB) modulation system developed by the Advanced Television Systems Committee (ATSC) and the Coded Orthogonal Frequency Division Multiplexing (COFDM) modulation adopted in the Digital Video Terrestrial Broadcasting (DVB-T) standard [59, 60]. Another DTTB modulation system also based on COFDM, the Bandwidth Segmented Transmission (BST)-OFDM system, is being finalized in Japan. Many countries are engaged in the process of selecting a DTTB system. Since each country has unique characteristics and needs, the selection of a DTTB system must be based on how well each of the two modulation systems meets the specific requirements of that country.

##### **4.4.1 General system comparison**

The ATSC 8-VSB system has a better robustness to the Additive White Gaussian Noise (AWGN) channel, higher spectrum efficiency, a lower peak-to-average power ratio, and is more robust to impulse noise and phase noise distortion. It also has comparable performance on low level ghost ensembles and analog TV interference into digital TV (DTV). Therefore, the ATSC 8-VSB system could be more advantageous for Multi-Frequency Network (MFN)

implementation and providing HDTV service within a 6 MHz channel. The DVB-T COFDM system has performance advantages on high level (up to 0 dB), long delay static and dynamic multipath distortion. It could be advantageous for services requiring Single Frequency Network (SFN) (8k mode) and mobile reception (2k mode). It should be pointed out, however, that SFN, mobile reception and HDTV service could not be achieved concurrently with any existing DTTB system over any channel spacing, i.e., 6, 7 or 8MHz. Specific system parameters must be selected for each particular implementation.

#### **4.5 MFN vs. SFN operation**

For Multi-Frequency Network implementation, where a high power transmitter is used to cover a large service area, the 8-VSB system seems advantageous. This is because, in this operation mode, the COFDM transmitter needs to be about 6 dB (or 4 times) more powerful than the 8-VSB transmitter for an equal coverage. This is due to the 3.5 dB higher Carrier-to-Noise (C/N) ratio requirement (numbers rounded to 0.5dB), and to the 2.5 dB peak-to-average power ratio (PAR) differences. The 3.5 dB higher field strength requirement will cause additional interference in to the analog TV services during the analog TV to DTV transition period. However, because of the better performance of the COFDM system on high level static and, more importantly, dynamic echoes, mobile reception (using the 2k mode) is possible, if a significant reduction in data rate, in comparison to fixed reception, is acceptable. (Data rate for mobile reception over a 6 MHz channel is likely to be limited to 4 to 12 Mbps.) On the other hand, the 8-VSB system was not specifically designed for Single Frequency Network implementation, where a cluster of transmitters is used to cover a designated service area. Limited on channel repeater and gap filler operation is possible, if enough isolation between the pick-up of the off-air signal and its retransmission can be achieved. The operational parameters will depend on the population distribution, terrain environment and intended coverage area. The 8k mode DVB-T system, designed for large scale (nation-wide or region-wide) SFN, needs at least 7 dB more signal power to deal with strong (0 dB) multipath distortions. This extra power requirement is in addition to the 6 dB transmitter headroom mentioned in the previous paragraph. One alternative to reduce the excess transmission power is to use a directional receiving antenna or assuming lower location availability. However, in this situation, the 8-VSB system might also operate properly, for the locations where there is no fast moving or long delay multipath

distortions. Another problem that might impact a large-scale SFN implementation is co-channel and adjacent channel interference. In many countries, it might be difficult to allocate a DTV channel for large-scale SFN operation that will not generate interference into existing analog TV services during the analog TV to DTV transition period. Finding additional tower sites at desired locations and the associated expenses (such as property, equipment, legal, construction, operation and environmental studies) might not be practical or economically viable to the broadcasters. On the other hand, the SFN approach, which provides stronger field strength throughout the core coverage area, can improve the service availability.

For indoor reception performance, both systems need to be further evaluated. The final choice of a DTV modulation system is therefore based on how well the two systems can meet the particular requirements or priorities of each country as well as other non-technical factors. Meanwhile, with the advance of new technologies, both systems can achieve performance improvements.

### **SIMULATION RESULTS FOR OFDM SYSTEMS WORKING UNDER IMPULSIVE NOISE ENVIRONMENT**

Orthogonal frequency division multiplexing (OFDM) is becoming the chosen modulation technique for wireless communications. OFDM can provide large data rates with sufficient robustness to radio channel impairments. Many research centers in the world have specialized teams working in the optimization of OFDM for countless applications. In an OFDM scheme, a large number of orthogonal, overlapping, narrow band sub-channels or subcarriers, transmitted in parallel, divide the available transmission bandwidth. The separation of the subcarriers is theoretically minimal such that there is a very compact spectral utilization. The attraction of OFDM is mainly due to how the system handles the multipath interference at the receiver. Multipath generates two effects: frequency selective fading and inter-symbol interference (ISI). The "flatness" perceived by a narrow-band channel overcomes the former, and modulating at a very low symbol rate, which makes the symbols much longer than the channel impulse response, diminishes the latter. Using powerful error correcting codes together with time and frequency interleaving yields even more robustness against frequency selective fading and the insertion of an extra guard interval between consecutive OFDM symbols can reduce the effects of ISI even more.

There are two main drawbacks with OFDM, the large dynamic range of the signal (also referred as peak-to average [PAR] ratio) and its sensitivity to frequency errors. These in turn are the main research topics of OFDM in many research centers around the world.

In this chapter we will investigate the effect of impulse noise on the OFDM wireless systems. The impulse noise originates from the manmade electrical and mechanical devices and from many natural sources, Therefore the nature of the impulse noise is not clear, but at the radio receiver we can only better guess about the energy content in the impulse noise through measurements. Here, we consider an OFDM system working in the wireless environment in which the signal is assumed to be contaminated by the impulse noise.

If we wish to develop some impulse noise through excetion and mitigation technique , we need to know about the characteristics of impulse noise at the receiver .Therefore the presented simulated results focus on the characterization of impulse noise in the stastical sense. For simulation in this analysis, we are using matlab software.

We have considered a sixteen QAM signal constellation for OFDM symbol transmission. In addition to impulse noise, additive white gaussian noise is also added in the transmitted OFDM signal, both positive and negative impulses are added . In first case signal to gaussian noise ratio is increased for the fixed number of impulses per OFDM symbol duration , and the variation in the symbol error is rate is observed as shown in Figure.25. It is clear that as the signal to noise ratio increases the performance of OFDM , wireless system deteriorates. More degradation in system performance in terms of symbol error rate is observed when the number of pulses per OFDM symbol duration is increased from four to eight. This degradation goes on increasing with the increasing number of impulses.

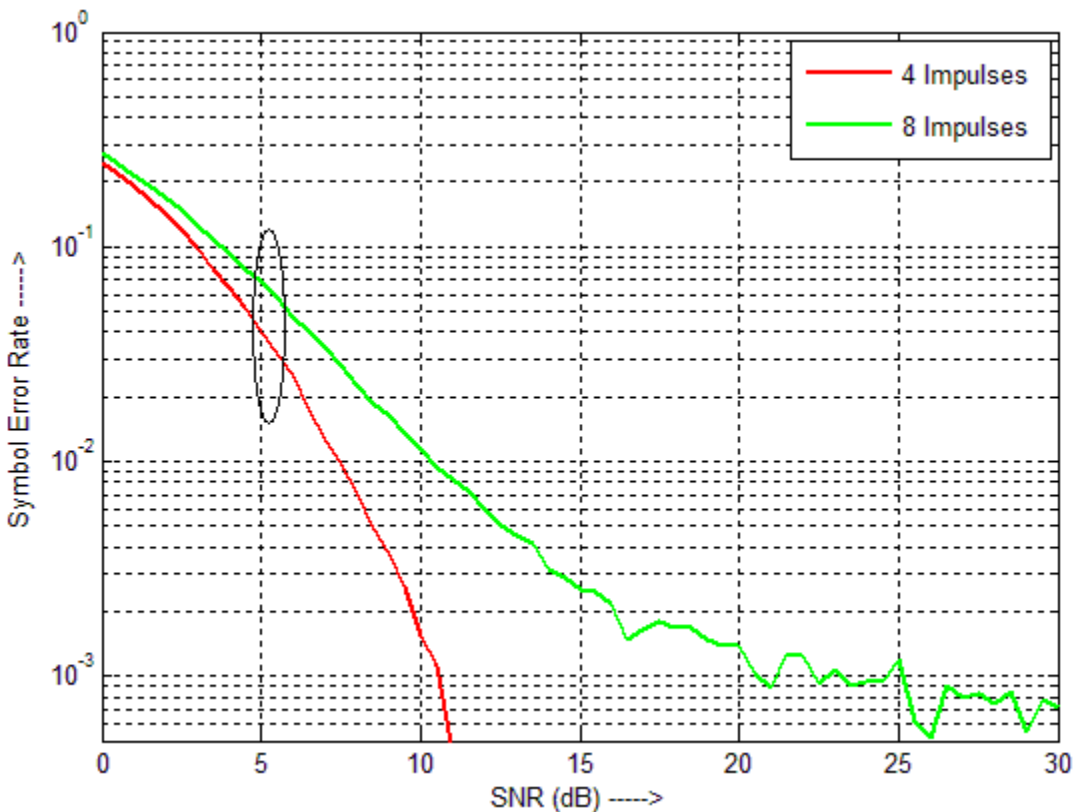

**Figure 25 Symbol error rate Vs SNR for different no. of Impulses**

In the next case , we have fixed the signal to gaussian noise ratio to 18db. Now, we vary the amplitude of noisy impulse from one to three and observe the variation in symbol error rate. The simulation results presented in Figure 26 depicts that the symbol error rate significantly increases with increasing amplitude of impulse noise. The performance further degrades when the number of impulses increases. This is due to increasing energy level of impulsive noise in per OFDM duration at the receiver.

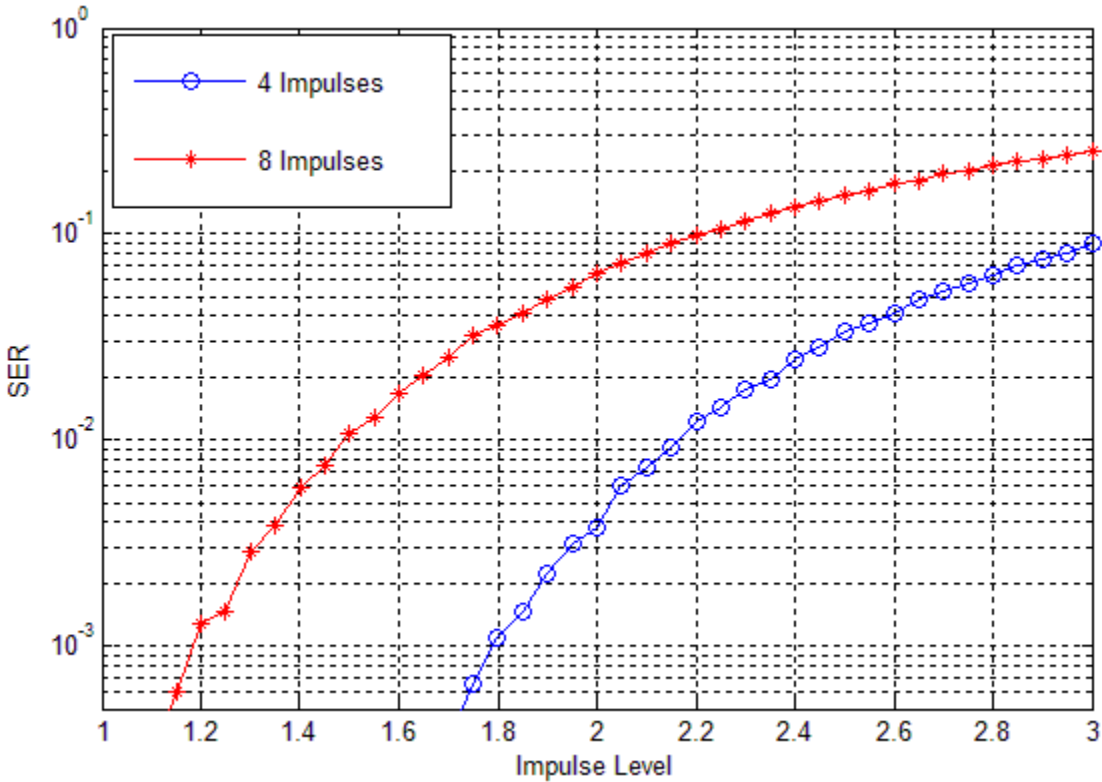

**Figure 26 SER Vs Impulse level for different no. of Impulses**

Further , we investigate the effect of increasing number of OFDM sub carriers and the long duration of OFDM symbol on impulse noise. For this we have plotted the simulation result in Fig. 3 for the variation of symbol error rate with respect to the varying amplitude of noisy impulse. Therefore , we have changed the number of sub carriers from thirty two to sixty four which in turn increases the symbol duration of OFDM. It is apprient from the stimulation result presented in Figure.27 that the symbol error rate increases with increasing amplitude of noisy impulse , which undoubtly depend upon the number of sub carriers or the symbol duration.

When the number of subcarriers is increased from thirty two to sixty four , the symbol error improves positively.

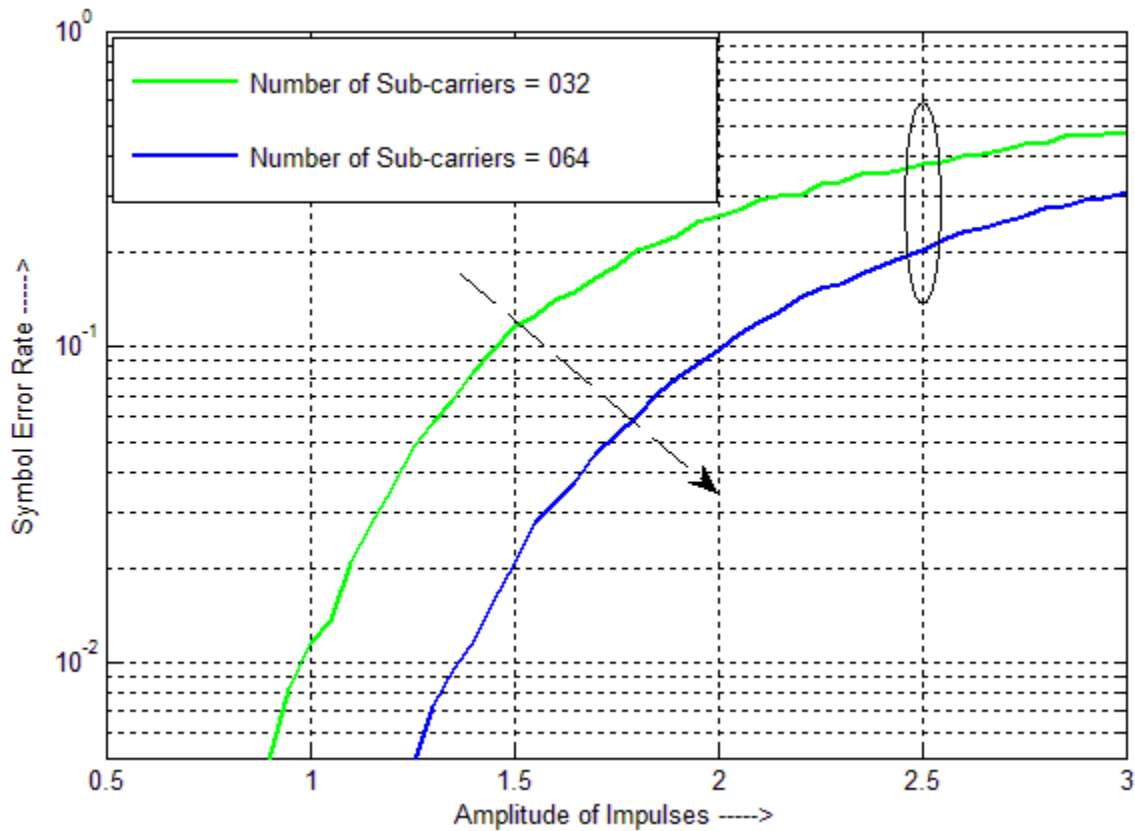

**Figure 27 SER Vs Amplitude of Impulses for different no. of sub-carriers**

Hence the performance of underline wireless OFDM system improves due to the spreading effect of DFT operation on impulse noise. It is because of the fact that the impulse noise energy gets spreaded over the large number of subcarriers and the impulse noise energy per OFDM symbol duration decreases from long OFDM in comparision to short OFDM.

The overall effect of impulse noise in the final symbol detection in the OFDM wireless receiver is approximately gaussian in nature. The gaussianess of impulse noise originates from the spreading effect of DFT operation at the receiver.

Hence, the overall performance of the presented orthogonal OFDM wireless system is dependent upon the total gaussian plus impulse noise content in the received composite signal. At the input

of fixed decision device the mixture of additive white gaussian noise and impulse noise may be considered approximate gaussian from analysis.

### CONCLUING REMARKS AND FUTURE SCOPE

OFDM has been widely used in communication systems to meet the demand for increasing data rates. It is robust over multipath fading channels and results in significant reduction of the transceiver complexity. However, one of its disadvantages is sensitivity to carrier frequency offset which causes attenuation, rotation of subcarriers, and inter-carrier interference (ICI).

The present study manifests that the noise bucket concept applies in quantify the performance of OFDM system impaired by impulse noise. The decision noise becomes approximately Gaussian even with the small number of impulse occurrences. Though the DFT/IDFT operation tries to combat the noise bucket effect, but the Gaussian background noise and high impulsive power may still deteriorate the symbol error rate of the OFDM systems working under wireless fading channels.

The impulsive noise can cause serious problems in the reception of OFDM signal, in DVBT systems. In this thesis work, we have investigated the impact of impulsive noise on such high data rate wireless communication systems through MATLAB simulation. We have concluded the following observations.

- The long OFDM symbols may combat impulsive noise better than the short OFDM symbol under similar conditions i.e. more number of sub carrier can reduce the effect of impulse noise by reducing the impulse noise per carrier.
- The impulse noise has lesser effect on the SER of underline OFDM systems only if the total energy per symbol reduces or the no. of impulses occurrence per symbol reduces.
- The effect of impulse noise at the final decision of OFDM symbol detection is nearly Gaussian. Therefore, for mathematical analysis the impulse noise components at the output of DFT operator may be considered approximated Gaussian distributed.

The carried research work is helpful in the further development of impulse noise reduction/excision technique. The future work includes the performance evaluation and investigation of SFBC-OFDM and STBC-OFDM wireless systems in the presence of Impulsive noise.

## REFERENCES

- [1] R.W Chang, "Synthesis of band limited Orthogonal Signals for multichannel data transmission" *Bell Syst. Tech. J.*, vol.45, pp. 1775-1796, Dec. 1966.
- [2] K. Fazel and G. Fettwis, "Performance of an Efficient Parallel Data Transmission System," *IEEE Trans. Commun. Tech.*, vol. 15, no. 6, pp. 805–813, Dec 1967.
- [3] R. Van Nee and R. Prasad, "*OFDM for Wireless Multimedia Communications*," Artech House Publishers, Massachusetts, 2000.
- [4] S. Weinstein and P. Ebert, "Data transmission by frequency division multiplexing using the discrete fourier transform," *IEEE Trans. Commun. Tech*, vol 19, pp. 628-634, October 1971.
- [5] A. Peled and A. Ruiz, "Frequency domain data transmission using reduced computational complexity algorithms," *IEEE Trans. Commun. Tech.*, vol 5, pp. 964-967, April 1980.
- [6] W. Warner and C. L. Leung, "OFDM/FM frame synchronization for mobile radio data communication," *IEEE Transactions on Vehicular Tech*, vol. 42, no. 3, pp. 302–313, August 1993.
- [7] W.Y. Zou, "Digital audio broadcasting (DAB) to mobile, portable and fixed receivers," *IEEE Trans. Commun. Tech*, vol. 3, pp. 1-8, Feb 1995.
- [8] M. Russell and G. Stuber, "Interchannel interference analysis of OFDM in a mobile environment," *Proceedings of IEEE VTC95, Chicago, IL*, vol. 2, pp. 820–824, July 1995
- [9] A. V. Oppenheim and R. W. Schaffer, "*Discrete time Signal Processing*," Prentice Hall, 1989.
- [10] J. Proakis, "*Digital Communications*", Tata Mc-Graw Hills, India, 1995.
- [11] Richard Van Nee and Ramjee Prasad, "*OFDM for Wireless Multimedia Communications*," Artech House Publishers, 2000.
- [12] S. Kaiser and P. Robertson, "The effects of doppler spread in OFDM mobile radio systems," *Proceedings of IEEE VTC*, vol. 1, pp. 329–333, 1999.
- [13] Y. Wu, "Performance comparison of ATSC 8-VSB and DVB-T COFDM transmission systems for digital television terrestrial broadcasting," *IEEE Trans. Consumer electron*, vol. 45, pp.916-924, Apr1999.

- [14] J. Armstrong, and H.A. Suraweera, "Impulse noise mitigation for OFDM using decision directed noise estimation," *IEEE ISSSTA 2004*, Sydney, Australia, Aug. Sep.2004
- [15] S.V Zhidkov, "Impulse noise suppression in OFDM based communication systems," *IEEE Trans. Consumer Electron.*, vol. 4, no. 49, pp.944-948, May 2003
- [16] R. Poole, "*DVB-T Transmission, Reception and Measurement*," DTG Monograph, June 2002.
- [17] D. Middleton, "Statistical-physical models of electromagnetic interference," *IEEE Trans. Electromagn. Compat.*, vol. EMC-19, pp. 106–127, Aug. 1977.
- [18] W. R. Lauber and J. M. Bertrand, "Statistics of motor vehicle ignition noise at VHF/UHF," *IEEE Trans. Electromagn. Compat.*, vol. 41, no. 3, pp. 257–259, Aug. 1999.
- [19] S. S. Rappaport and L. Kurz, "An optimal nonlinear detector for digital data transmission through non-Gaussian channels," *IEEE Trans. Comm. Technol.*, vol.14, pp. 266–274, Jun. 1966.
- [20] O. Antonov, "Optimal detection of signals in non-Gaussian noise," *Radio Eng. Electron. Phys. (USSR)*, vol. 12, pp. 541–548, 1967.
- [21] K. S. Vastola, "Threshold detection in narrow-band non-Gaussian noise," *IEEE Trans. Commun.*, vol. COM-32, no. 2, pp. 134–139, Feb. 1984.
- [22] S. Wei et al., "A modern extreme value theory approach to calculating the distribution of the peak-to-average power ratio in OFDM systems," in *Proc. IEEE Int. Conf. Communications*, vol. 3, pp. 1686–1690, Apr.-May 2002.
- [23] Abdelkefi, et al. "Impulsive Noise Cancellation in Multicarrier Transmission," *IEEE Transactions on Communications*, vol-53, pp. 94-106, Jan 2005.
- [24] J. K. Wolf, "Redundancy, the discrete Fourier transform, and impulse noise cancellation," *IEEE Transaction on Communications*, vol. 31, pp.458-461, Mar 1983.
- [25] R. Kumaresan, "*Rank Reduction Techniques and burst error-correction decoding in real/complex fields*," in Proc. Asilomar conf., circuits, syst., comput., Nov 1985.

- [26] K. L. Blackard et al., "Measurement and models of radio frequency impulsive noise for indoor wireless communications," *IEEE J. Sel. Areas Commun.*, vol. 11, pp. 991-1001, Sept. 1993.
- [27] J. Lin , M. Nassar and B. L. Evans, " Non-parrametric impulsive noise mitigation in OFDM systems using sparse bayesian learning", *IEEE Int. global comm. conf.*, Houston, TX USA, Dec. 2011.
- [28] H. A. Suraweera et al., "Analysis of impulse noise mitigation techniques for digital television systems," *Proc. 8th International OFDM Workshop*, pp. 172-176, Sept. 2003.
- [29] O. Antonov, "Optimal detection of signals in non-Gaussian noise," *Radio Eng. Electron. Phys. (USSR)*, vol. 12, pp. 541-548, 1967.
- [30] N. Rozic and J. Radic, "Distribution of the squared norm in OFDM systems interfered by class A impulsive noise," *IEEE commun.lett.* vol.14, no.4, pp.318-320, Apr.2011
- [31] J. Bingham, "Multicarrier modulation for data transmission, an idea whose time has come," *IEEE Commun. Mag.*, no. 28, pp. 14–15, Apr. 1990.
- [32] M. Alard and R. Lassalle, "Principles of modulation and channel coding for digital broadcasting for mobile receivers," *EBU Rev.*, pp. 168–190, Aug. 1997.
- [33] P. S. Chow et al., "Performance evaluation of a multichannel transceiver system for ADSL and HDSL services," *IEEE J. Sel. Areas Commun.*, vol. 9, pp. 909–919, Aug. 1991.
- [34] F. Abdelkefi et al. "*Impulse noise cancellation in multicarrier transmission*," in *Proc. Int. Conf. Aco.,Speech Signal Process.*, vol. 4, May 2001, pp. 2381–2384
- [35] J.-L. Wu and J. Shiu, "Discrete cosine transform in error control coding," *IEEE Trans. Commun.*, vol. 43, pp. 1857–1861, May 1995.
- [36] F. Marvasti, M. Hasan, M. Echhart, and S. Talebi, "Effecient algorithms for burst error recovery using FFT and other transform kernels," *IEEE Trans. Signal Process.* vol. 47, pp. 1065–1075, Apr. 1999.
- [37] G. R. Redinbo, "A fault-tolerant decoding procedure for real cyclic codes," in *Proc. Pacific Rim Int. Symp. Fault-Tolerant Syst.*, Taipei, Taiwan, Dec. 1997, pp. 35–40

- [38] Lind, L.F., and Mufti, N.A, “Efficient method for modelling impulse noise in a communication system”, *Electron. Lett.*, May 1996,
- [39] E. Biglieri and P. de Torino, “Coding and modulation for a horrible channel,” *IEEE Commun. Mag.*, vol. 41, no. 5, pp. 92–98, May 2003.
- [40] A. D. Spaulding and D. Middleton, “Optimum reception in an impulsive interference environment-Part I: Coherent detection,” *IEEE Trans. Comm.*, vol. 25, pp. 910–922, Sep. 1977.
- [41] J. Haring and A. H. Vinck, “Iterative decoding of codes over complex numbers for impulsive noise channels,” *IEEE Trans. Inf. Theory*, vol. 49, no. 5, pp. 1251–1260, May 2003.
- [42] Y. H. Ma, P. L. So, and E. Gunawan, “Performance analysis of OFDM system for broadband power line communications under impulsive noise and multipath effects,” *IEEE Trans. Power Del.*, vol. 20, no. 2, pt. 1, pp. 674–682, Apr. 2005.
- [43] J. Bingham, “Multicarrier modulation for data transmission: An idea whose time has come,” *IEEE Commun. Mag.*, vol. 28, no. 5, pp. 5–14, May 1990.
- [44] S. Lin and D. J. Costello, “*Error control coding*,” 2nd ed. Upper saddle river, NJ: Prentice-Hall, Aug.2004.
- [45] N. H. Tran and H. H. Nguyen, “Signal mappings of 8-ary constellations for bit-interleaved coded modulation with iterative decoding,” *IEEE Trans. Broadcast.*, vol. 52, no. 1, pp. 92–99, Jan. 2006.
- [46] T. Q. Bui and H. H. Nguyen, “*Bit-interleaved coded mod.*,” Aug 2008.
- [47] Yong Jae Ryu , Dong seong Han, “Timing phase estimator overcoming Rayleigh fading for OFDM systems,” *IEEE Proc.*, vol 1, pp. 66-67, May 2001.
- [48] M. Nakagami, “The m-distribution A general formula of intensity distribution of rapid fading,” in *Statistical Methods in Radio Wave Propagation*, W. C. Hoffman, Ed. Elmsford, NY: Pergamon, 1960
- [49] Zhangyong Ma and Young-il- Kim, “A novel OFDM receiver in flat fading channel,” *IEEE Conference*, Vol. 2, pp.1052-54, June 2005.
- [50] Basel Rihawi and Yves Louet, “Gaussian and Flat Rayleigh Fading Channel Influences on PAPR Distribution in MIMOOFDM Systems,” *13th European Wireless Conference*, Paris, April 2007.

- [51] Jyoteesh Malhotra et al. "On the Performance Analysis of Wireless Receiver using Generalized-Gamma Fading Model, in *annals of telecommunications international journal*, Springer , Vol. 64, No 1-2, pp. 147-153, January-February 2009.
- [52] Carl Eklund et at., "Broadband Radio Access Networks (BRAN)," *European Telecommunications Standards Institute*, Dec. 2001
- [53] Yiyan Wu, "Performance comparison of ATSC 8-VSB and DVB-T COFDM transmission systems for digital television terrestrial broadcasting", *IEEE Trans. Consumer Electron.*, Vol. 45, No. 3, Aug. 1999
- [54] T.C. Giles, "On the design of HF radio modems", Ph.D. dissertation, University of Adelaide, Dec. 1995
- [55] J. Haring and A.J. Han Vinck, "Iterative decoding of codes over complex numbers for impulsive noise channels," *IEEE Trans. Inform. Theory*, Vol. 49, No.5, May 2003
- [56] M. G. Sanchez et al., "Impulsive noise measurements and characterization in a UHF digital TV channel," *IEEE Trans. Electromagn. Compat.*, vol. 41, pp. 124-136, May 1999
- [57] M. Ghosh, "Analysis of the effect of impulse noise on multicarrier and single carrier QAM systems," *IEEE Trans. Commun.*, vol. 44, pp. 145- 147, Feb. 1996.
- [58] H. A. Suraweera, C. Chai, J. Shentu and J. Armstrong, "Analysis of impulse noise mitigation techniques for digital television systems," in *Proc. 8th International OFDM Workshop (InOWo '03)*, Hamburg, Germany, Sept. 2003
- [59] F. Abdelkefi et al., "On the use of pilot tones for impulse noise cancellation in Hiperlan2," in *Proc. ISSPA*, Kuala Lumpur, Malaysia, Aug. 2001.
- [60] K. Gulati et al., "Radio frequency interference modeling and mitigation toolbox," *IEEE Trans. Commun.*, vol. 58, pp.6207-6222, Apr. 1, 2011.