

**8X8 MIMO SYSTEM USING PRECODED AND CONVOLUTION  
ENCODED LINEAR DISPERSION CODES**

A Dissertation submitted in the partial fulfillment of requirement for the award of degree of

**Master of Engineering**

**In**

**Electronics and Communication Engineering**

**Submitted by:**

Satinder Kaur

Roll No : 801261019

**Under the guidance of:**

Ankush Kansal

Assistant Professor, ECED

Thapar University, Patiala



**ELECTRONICS AND COMMUNICATION ENGINEERING  
DEPARTMENT**

**THAPAR UNIVERSITY**

**(Established under the section 3 of UGC Act, 1956)**

**PATIALA – 147004 (PUNJAB)**

## CERTIFICATE

---

I hereby declare that the thesis report entitled "8X8 MIMO SYSTEM USING PRECODED AND CONVOLUTION ENCODED LINEAR DISPERSION CODES" is an authentic record of my study carried out as requirement for the award of degree of M.E. (ECE) at Thapar University, Patiala, under the supervision of **Ankush Kansal**, Assistant Professor, Electronics and Communication Engineering Department.

The matter presented in this thesis has not been submitted in any other University/ Institute for the award of any other degree.

Date: 9/7/14

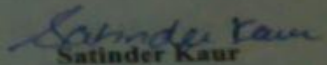
  
Satinder Kaur  
Roll No-801261019

It is certified that the above statement made by the student is correct to the best of my knowledge and belief.

Date: 9/7/14

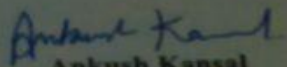
  
Ankush Kansal  
Assistant Professor,  
ECED

Countersigned by:

  
(Dr. Sanjay Sharma)

Professor and Head

ECED, Thapar University,

Patiala, Punjab

  
(Dr. S. K. Mahopatra)

Dean of Academic Affairs

Thapar University,

Patiala, Punjab

## ACKNOWLEDGEMENT

---

First of all, I would like to express my gratitude to **Ankush Kansal**, Assistant Professor, Electronics and Communication Engineering Department, Thapar University, Patiala for his patient guidance and support throughout this report. I am truly very fortunate to have the opportunity to work with him.

I am also thankful to our **Head of the Department, Dr. Sanjay Sharma** as well as **PG Coordinator, Dr. Kulbir Singh, Associate Professor**, Electronics and Communication Engineering Department, entire faculty and staff of Electronics and Communication Engineering Department and then friends who devoted their valuable time and helped me in all possible ways towards successful completion of this work. I thank all those who have contributed directly or indirectly to this work. Lastly, I would also like to thank my parents for their years of unyielding love and encourage. They have always wanted the best for me and I admire their determination and sacrifice.

**Satinder Kaur**

# Table of Contents

<b>1. Introduction.....</b>	<b>1</b>
1.1 Evolution of Wireless Communication .....	1
1.2 MIMO Systems .....	2
1.2.1 MIMO System Model .....	2
1.3 Capacity of MIMO Systems .....	5
1.4 MIMO Reliability: Improvement In BER Performance .....	9
1.4.1 Spatial multiplexing .....	9
1.4.2 Diversity Coding .....	10
1.5 Space Time Coding .....	10
1.5.1 Space Time Block Codes .....	11
1.5.1.1 Alamouti Codes .....	12
1.5.1.2 Generalized OSTBC .....	12
1.5.1.3 QOSTBC .....	12
1.5.1.4 Linear Dispersion Codes .....	13
1.5.1.5 Linear Orthogonal Dispersion Codes .....	14
1.6 Capacity and Diversity trade off .....	14
1.7 Precoding .....	15
1.8 Channel Coding .....	17
1.8.1 Convolution Encoding .....	18
1.8.2 Puncturing .....	18
<b>2. Literature Review .....</b>	<b>20</b>
<b>3. Gaps and Objectives .....</b>	<b>26</b>
<b>4. 8X8 MIMO Using Precoded Linear Dispersion Codes .....</b>	<b>28</b>
4.1 Uncoded 8×8 MIMO System Model .....	29
4.2 8X8 MIMO Using Precoded Linear Dispersion Codes .....	31
4.2.1 Precoded LDC 8X8 MIMO System Model.....	31

4.2 .2 Linear Dispersion Code Construction Model .....	33
4.2.3 Decoding of P- LDC Coded 8X8 MIMO .....	35
4.3 Convolution Encoded and Bit Interleaved linear Dispersion Codes in 8X8 MIMO.....	35
4.3.1 Convolution Encoder .....	36
4.3.2 Bit Interleaving .....	37
<b>5. Results and discussion .....</b>	<b>39</b>
<b>6. Conclusion and future scope .....</b>	<b>44</b>
<b>References .....</b>	<b>46</b>

## LIST OF FIGURES

---

1.1 Basic MIMO System .....	3
1.2 Comparison of ergodic capacity of 2x2, 4x4, 8x8 MIMO System .....	7
1.3 Comparison of outage capacity of 2x2,4x4, 8x8 MIMO System .....	8
1.4 Spatial Multiplexing System .....	9
1.5 Convolution encoder with $K=3, k=1, n=3$ .....	18
2.1 Schematic representation of BLAST system .....	21
4.1 8X8 MIMO system .....	30
4.2 Block Diagram of Precoded LDC coded 8 antennas MIMO transmitter .....	32
4.3 Block Diagram of Precoder .....	33
4.4 Block Diagram of 8X8 MIMO System model using convolution encoder .....	36
4.5 Architecture of Convolution Encoder for generator polynomial (171,133) .....	37
5.1 BER analysis of uncoded 8x8 MIMO System .....	39
5.2 BER analysis of Linear Dispersion Coded 8x8 MIMO System .....	40
5.3 BER comparison of uncoded and LDC coded 8x8 MIMO System .....	41
5.4 BER analysis of Precoded Linear Dispersive Codes for $M=8, N=8$ MIMO System ....	42
5.5 BER comparison of LDC coded 8X8 MIMO with and without use of convolution encoder at tx.....	43

## LIST OF TABLES

---

1. Transmission of symbols in two different time periods in Alamouti Technique .....11
2. Transmission of symbols in two different time periods in spatial multiplexing .....29

## ABSTRACT

As the desire for wireless transfer of high speed data in small, handheld units is increasing, consumer demands have exceeded the technological ability of existing wireless communication systems. In order to fulfill the desire for faster, more reliable communications, it is mandatory for the next generation wireless communication systems to achieve very high throughputs and improved reliability, even in the presence of harsh channel conditions. Unfortunately, consumer demands for higher data rates have rapidly surpassed the capabilities of existing wireless technologies. Present generation cellular phones cannot achieve higher data rates to satisfy most wireless consumers who are adapted to the extremely high data rates of wired networked systems. This has raised a need for new research into methods of supporting higher data rates for next generation wireless systems.

In order to achieve outstanding reliability and exceptionally high capacity the most promising technique is to use Multiple Input, Multiple Output (MIMO) systems. MIMO systems utilize multiple antennas at the transmitter and receiver sides. LTE-advanced aims to use 8x8 MIMO and 128 QAM and promises to deliver 1Gbits/s at fixed speeds and 100Mbits/s to mobile users. Since the need of the present era is to improve data rates thereby reducing error rates. Major challenges for next generation wireless systems is the development of efficient coding and signal processing techniques so that spectral efficiency for large number antenna systems i.e. 8x8 systems is improved.

Space-time codes create redundancy by spreading symbols in space and time, which improves bit error rates (BER) but rate is reduced for large number antennas. Spatial multiplexing techniques improve capacity but do not optimize BER performance. Linear Dispersion Codes (LDCs) are linear codes in structure that spread data symbols using dispersion matrices. High rates and good error performance is guaranteed for any arbitrary number of transmitter antennas. In conventional LDC techniques it is assumed that there is no knowledge of the channel at the transmitter. However, in order to convey channel state information (CSI) feedback from receiver to transmitter can be established. Such systems are called precoding systems.

To achieve high data rates and low error rates for larger number of antennas, the focus of this work is to investigate the performance of 8X8 MIMO systems using Linear Dispersion

Codes and Precoded Linear Dispersion Codes when CSI is used at the transmitter. The effect of channel known is only improving the performance at low SNRs. Precoding improves the symbol error rate performance of linear dispersion codes at lower SNR's i.e. up to SNR 18dB. In precoded 8X8 LDC coded MIMO symbol error rate of  $10^{-1.5}$  is obtained at SNR of 7dB whereas without precoding at 13 dB, hence there is 6dB system performance improvement. In order to combat the burst errors due to channel convolution encoding and bit interleaving is used along with Linear Dispersion Codes and performance is improved at higher SNR's i.e. above 15 dB. Using convolution encoding symbol error performance of  $10^{-4.0}$  is obtained at SNR of 20dB whereas without channel coding at same symbol error performance is obtained at 24 dB, hence 4dB performance improvement is obtained.

# CHAPTER 1

## INTRODUCTION

---

This chapter introduces the high capacity demands of future wireless systems and this capacity can be achieved by MIMO systems. An overview of high capacity MIMO systems is discussed.

During the last decade wireless communication has been under tremendous growth in both voice and data applications. The wireless capability smart phones and laptops have become very common. The voice quality of cell phones has been improving as well as the data rate of wireless LANs has also reached exceptional higher levels of hundreds of megabits per seconds. Due to increasing consumer demands the technological ability of existing wireless infrastructures is continuously upgraded. In new generation wireless connections additional capabilities are being added such as broadband voice and data on a single unit, video broadcasting on cell phones, and replacing cables with high-speed wireless connectors. The wireless system designers are facing several challenges. The limitation of the radio spectrum and the complexity of wireless propagation environment, moreover the increasing demand for better quality of service (QoS) and higher transmission data rate.

### 1.1 Evolution of Wireless Communication

Wireless communication systems are under advancements, in the first generation (1G) Systems the main techniques used at that levels was Frequency Division Multiple Access (FDMA). Nowadays, in order to enhance bandwidth efficiency and accommodate more users Time Division Multiple Access (TDMA) and Code Division Multiple Access (CDMA) multiple access techniques are widely used in communication systems [1]. To access the limited radio spectrum simultaneously by large number of users, three multiple access schemes are used. Several problems are faced by the wireless system designers like the limitation of the radio spectrum, the increasing demand for better quality of service (QoS) and higher transmission data rate. Traditional wireless communication systems have been made more spectrally efficient through the use of complex coding techniques and algorithms.

By keeping in mind the constraint of limited bandwidth the MIMO systems is a hot topic of research over the past years, due to its ability to greatly increase spectral efficiencies. As compared to traditional wireless systems, there was use of one transmitting and one receiving antenna, MIMO systems use array of multiple antennas at both ends of the communication link, all operating at the same frequency at the same time [2-3]. This results in spatial diversity into the system, which can be used to combat the problem of multipath fading. In wireless communications system, such as point to point radio links, radio waves do not simply propagate from the transmit antenna to the receive antenna. Rather they bounce and scatter off objects, this effect is known as multipath. Therefore, this effect is regarded as an obstacle to the accurate transmission of data in traditional wireless links [4]. MIMO systems exploit multipath as an advantage by using the rich scattering environment to increase the spectral efficiency of the wireless system.

In order to achieve outstanding reliability and exceptionally high capacity the most promising technique is to use Multiple Input, Multiple Output (MIMO) systems.

## **1.2 MIMO Systems**

MIMO systems are defined as the systems containing multiple transmitter antennas and multiple receiver antennas. It has been shown by communication theories that MIMO systems can provide a potentially very high capacity that, grows approximately linear with the number of antennas. MIMO Systems using smart modulation schemes provide much higher spectral efficiencies than traditional SISO systems.

### **1.2.1 MIMO System Model**

Consider there are M transmitter and N receiver antennas. The input/output relationship of a MIMO system is given by

$$Y = Hs + v \quad (1)$$

Where  $s = [s_1, s_2, \dots, s_M]^t$  is the  $M \times 1$  transmit signal vector with  $s_i$  belonging to a finite constellation A.  $Y = [y_1, y_2, \dots, y_N]^t$  is the  $N \times 1$  received signal vector.  $v = [v_1, v_2, \dots, v_N]^t$  is the received noise vector.

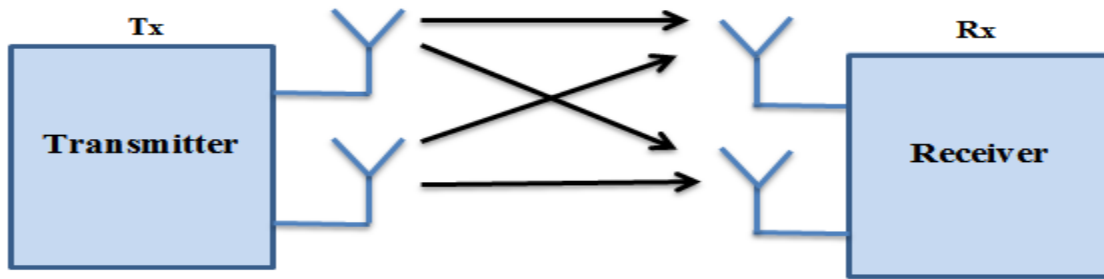

**Fig. 1.1 Basic MIMO System**

$H$  is  $N \times M$  channel matrix. Each element of the channel matrix is denoted by  $\{h_{ij}\}$ .

The channel matrix shows the complex gain of the channel between the  $j^{\text{th}}$  transmitter and the  $i^{\text{th}}$  receiver. In case of  $8 \times 8$  MIMO system the channel response matrix for  $8 \times 8$  systems is given by

$$\begin{bmatrix} y_1 \\ \vdots \\ y_8 \end{bmatrix} = \begin{bmatrix} h_{11} & \cdots & h_{18} \\ \vdots & \ddots & \vdots \\ h_{81} & \cdots & h_{88} \end{bmatrix} \begin{bmatrix} s_1 \\ \vdots \\ s_8 \end{bmatrix} + \begin{bmatrix} v_1 \\ \vdots \\ v_8 \end{bmatrix} \quad (2)$$

The performance enhancement with the use of MIMO system is due to diversity gain, spatial multiplexing gain, array gain and interference reduction.

### **a. Array Gain**

Array gain is the power gain that is achieved by combining different antennas in MIMO systems. In order to achieve array gain processing is done at the transmitter and the receiver whose consequence is increase in average received SNR due to a coherent combining effect. For transmit or receive array gain channel knowledge is required at the both transmitter and receiver [8]. Array gain depends upon number of transmit and receive antennas i.e. proportional to length of array.

### **b. Diversity Gain**

Fading is defined as random fluctuation of the signal power in wireless channel. Fading in wireless links can be removed by using diversity techniques. Diversity techniques involve transmitting the same signal over multiple independently fading paths (in

time/frequency/space). In a MIMO system with M transmitter and N receiver antennas, there are  $MXN$  links in MIMO channel fade independently and the transmitted signal at the receiver is combined, the resultant signal exhibits very less amplitude variability as compared to SISO system and diversity order of  $[MXN]^{\text{th}}$  is obtained. Time/frequency diversity involves expenditure in bandwidth and transmission line, hence spatial i.e antenna diversity is preferred. The extraction of spatial diversity gain is possible using designed transmit signals by using technique known as space-time coding even in the absence of channel knowledge at the transmitter [5]. In diversity coding techniques the signal is coded using space time coding techniques and single stream is transmitted unlike multiple streams in spatial multiplexing. The signal is emitted from each of the transmit antennas using certain principles of full or near orthogonal coding. Since channel state knowledge is not used, so there is no beam forming or array gain from diversity coding.

### **c. Spatial Multiplexing Gain**

MIMO channels offer a linear increase in capacity for no additional power or bandwidth expenditure [6-7]. This gain is referred to as spatial multiplexing gain. In spatial multiplexing, a high rate signal is divided into several lower rate streams and each low rate stream is transmitted from a different transmit antenna using same frequency channel. Under rich scattering environment, the receiver can separate the different streams, which results in a linear increase in capacity. With eight transmitter and receiver antennas capacity is very much enhanced.

### **d. Interference Reduction**

Frequency reuse in wireless channels gives rise to co channel interference. When multiple antennas are used, the difference in the spatial signatures of the co channel signals and the desired signals is helpful in reducing interference. In order to reduce interference knowledge of the desired signal channel is required whereas accurate knowledge of the interferer's channel may not be essential [8]. The interference energy reaching towards the co channel users should be minimized to deliver signal to the desired user. Interference reduction increases the multicell capacity by allowing aggressive frequency reuse. In general it is not

possible to take advantage of all the leverages of MIMO technology simultaneously because of trade off between capacity gain and diversity gain characterized in [7].

### 1.3 Capacity of MIMO Systems

Channel Capacity is a measure of how much information per channel usage can be obtained through a channel i.e how much information that can be transmitted and received with a minor probability of error [9]. It is measure of maximum error free transmission data rate. If the input and output of the memory less wireless channel is represented by random variables X and Y, the capacity of a random MIMO channel with power constraint P can be expressed as [9]

$$C = E_H \{ \max I(x; y) \} \quad (3)$$

where  $I(x; y)$  represents the mutual information between input X and output Y. The mathematical expression for ergodic capacity of complex AWGN MIMO channel is expressed as

$$C = E_H \left\{ \log_2 \left[ \det \left( I_N + \frac{P}{\sigma^2_M} HH^\dagger \right) \right] \right\} \quad (4)$$

This can also be written as

$$C = E_H \left\{ \log_2 \left[ \det \left( I_N + \frac{\rho}{M} HH^\dagger \right) \right] \right\} \quad (5)$$

where  $\rho$  is the average signal-to noise (SNR) ratio received at the receiver branch. By the law of large numbers, the term  $\frac{1}{M} HH^\dagger \rightarrow I_N$  as M gets large and N is fixed.

Further analysis of the MIMO channel capacity is done by diagonalizing the product matrix  $HH^\dagger$  either by eigen value decomposition or by singular value decomposition. By using Eigen value decomposition

$$HH^\dagger = E \Lambda E^\dagger \quad (6)$$

where E is the eigenvector matrix whose columns are orthonormal to each other.  $\Lambda$  is a diagonal matrix consists of eigen values on the main diagonal. Using the above equation notation can be written as:

$$C = E_H \left\{ \log_2 \left[ \det \left( I_N + \frac{\rho}{M} \right) E \Lambda E^\dagger \right] \right\} \quad (7)$$

Applying singular value decomposition on the channel matrix  $H$ , it can be written as

$$H = U \Sigma V^\dagger \quad (8)$$

where  $U$  and  $V$  are unitary matrices of left and right singular vectors respectively, and  $\Sigma$  is a diagonal matrix. The diagonal matrix has singular values on the main diagonal. All elements on the diagonal are zero except for the first  $k$  elements. The rank of channel matrix equals the number of non-zero singular values  $k$ . Using (8) in (4), the MIMO channel capacity can be written as

$$C = E_H \left\{ \log_2 \left[ \det \left( I_N + \frac{\rho}{M} \right) U \Sigma \Sigma^\dagger U^\dagger \right] \right\} \quad (9)$$

After diagonalizing the product matrix  $HH^\dagger$ , the capacity formulas of the MIMO channel now includes unitary and diagonal matrices only. This shows that the total capacity of a MIMO channel is sum of parallel AWGN SISO sub channels. The number of parallel sub channels is determined by the rank of the channel matrix. The rank of the channel matrix is given by

$$\text{rank}(H) = k \leq \min \{M, N\} \quad (10)$$

Using (10) together with the fact that the determinant of a unitary matrix is equal to 1, (7) and (9) can be expressed respectively as

$$C = E_H \left\{ \sum_{i=1}^k \log_2 \left( 1 + \left( \frac{\rho}{M} \right) \lambda_i \right) \right\} \quad (11)$$

$$= E_H \left\{ \sum_{i=1}^k \log_2 \left( 1 + \left( \frac{\rho}{M} \right) \sigma_i^2 \right) \right\} \quad (12)$$

In (11),  $\lambda_i$  are the eigen values of the diagonal matrix  $\Lambda$  and in (12),  $\sigma_i^2$  are the squared singular values of the diagonal matrix  $\Sigma$ . The maximum capacity of a MIMO channel is reached in the unrealistic situation when each of the  $M$  transmitted signals is received by the same set of  $N$  antennas without interference. It can also be described as if each transmitted signal were received by a separate set receive antennas giving a total number of  $M \cdot N$  receiving antennas.

### a. Ergodic Capacity

Ergodic capacity is the measure of spectral efficiency of the MIMO system[9].When there is no CSI available at transmitter side the data transmission takes place over all fading states i.e deep fades and hence rate is reduced. The mutual information achieved with this covariance matrix is given by

$$I_{CU} = \log_2 \det(I_N + (\frac{E_s}{M}) H H H) \quad (13)$$

which may be decomposed as:

$$I_{CU} = \sum_{i=1}^r \log_2(1 + (\frac{E_s}{M}) \lambda_i) \quad (14)$$

It can be shown that when both M and N increase, the capacity increases linearly with respect to min(M,N)[10]. This behavior of the ergodic capacity with the increase in number of transmitter and receiver antennas is as shown in the following curves.

Fig.1.2 shows increase in ergodic capacity with increase in number of antennas. The capacity depends upon the order of the receiver and transmitter antennas under certain limits. There is increase in the channel capacity because of the uncorrelated channel paths.

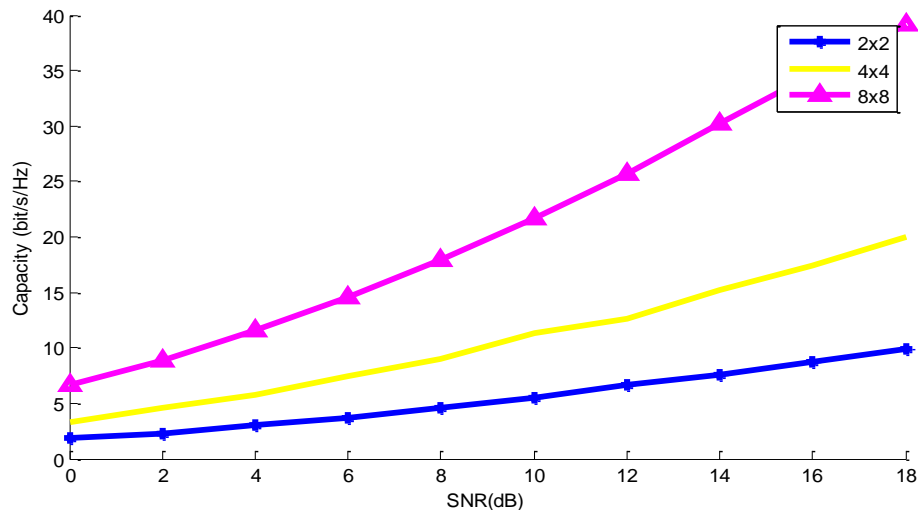

**Fig.1.2 Comparison of ergodic capacity of 2x2, 4x4, 8x8 MIMO System[9]**

At SNR of 10dB , when Mt=2 ergodic capacity is upto 5bits/hz, for Mt=4 ergodic capacity is upto 9bits/hz and for Mt=8 ergodic capacity is 24bits/hz. The above results shows increase in ergodic capacity with increase in number of transmit antennas. Channel capacity is reduced

when correlated signals i.e. signals with same spatial signature are received .Hence Correlation among the sub-channels results in the degradation in the spectral efficiency of MIMO channels. In order to reduce this degradation due to correlation diversity coding is done.

### b. Outage Capacity

Outage capacity is another measure used to measure the capacity of the channel. The information cannot be decoded without errors if the channel capacity falls below the outage capacity, whichever coding scheme is employed[11].The probability that capacity is less than outage capacity is given by the probability that the capacity is less than the outage (denoted by  $C_{\text{outage}}$ ) is  $q$ . This can be given mathematically as

$$\text{Prob} \{C \leq C_{\text{outage}}\} = q \tag{15}$$

The outage capacity depends on the allowed outage probability.

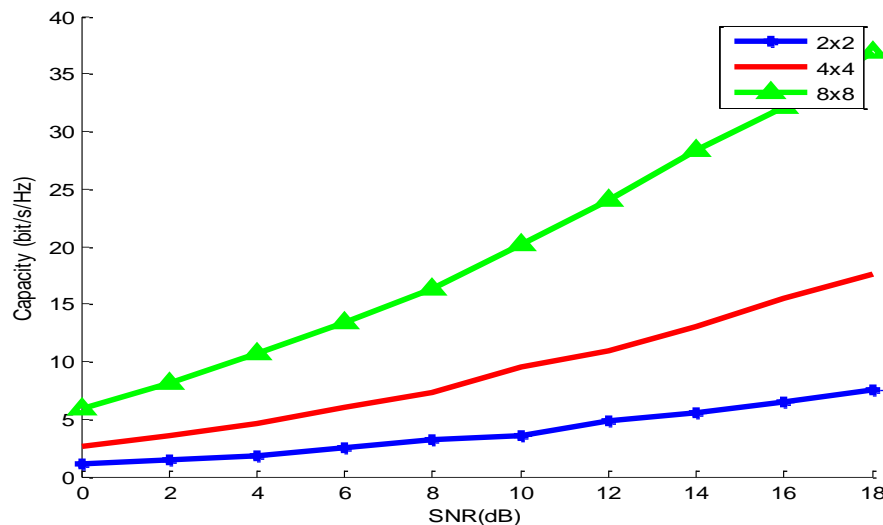

**Fig.1.3 Comparison of outage capacity of 2x2,4x4, 8x8 MIMO System[9]**

Fig.1.3 shows increase in increase of the outage capacity with increase in number of antennas. At SNR of 10dB , when  $M_t=2$  ergodic capacity is upto 4bits/hz, for  $M_t=4$  outage capacity is upto 7bits/hz and for  $M_t=8$  ergodic capacity is 20bits/hz. The above results shows increase in ergodic capacity with increase in number of transmit antennas.

## 1.4 MIMO Reliability : Improvement in BER Performance

The most promising way to reach higher spectral efficiency than today is the deployment of usage of large antenna arrays enabling up to eight stream (8X8) MIMO. Moreover, besides MIMO the higher SINR in small cells supports the usage of high order modulation schemes like 64 QAM. Many MIMO techniques have been proposed targeting at different scenarios in wireless communications. Three techniques are available for improving spectral efficiency. These are as follows:

### 1.4.1 Spatial multiplexing

It requires multiple transmitter and receiver antenna configuration. In spatial multiplexing, a high rate signal is split into multiple lower rate streams and each stream is transmitted from a different transmitter antenna in the same frequency channel. If these transmitted signals arrive at the receiver antennas with different spatial signatures, the receiver can separate these streams, which results in creating parallel channels[6]. Spatial multiplexing is a very powerful technique for increasing channel capacity at higher Signal to Noise Ratio (SNR).

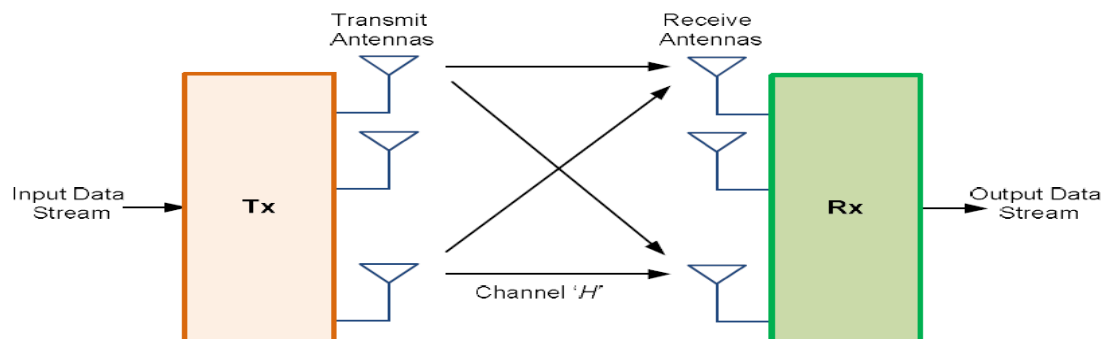

**Figure 1.4 Spatial Multiplexing System**

The maximum number of spatial streams i.e maximum data rate is limited by the lesser in the number of antennas at the transmitter or receiver. Spatial multiplexing can be used with or without transmit channel knowledge.

### 1.4.2 Diversity Coding

In wireless channel, signal power changes with frequency, time and space. Due to fading signal power levels of the signal falls drastically. To mitigate the effect of fading diversity

coding i.e. Space Time Coding is used. Diversity techniques are used when channel state knowledge is not known at the transmitter [14]. In diversity methods a single stream is transmitted which is coded using techniques called space time coding. The signal is emitted from each of the transmitter antennas such that the principle of full orthogonality is fulfilled. In this case the receiver is provided with multiple copies of a faded signal. There is no array gain from diversity coding due to the absence of channel knowledge. Mathematically, diversity gain is obtained from the slope of symbol error rate (SER) versus SNR graph.

#### - *Receive Diversity*

Receiver Diversity can be used in channels where multiple antennas are present at the receiver side. The received faded signals are combined at the receiver so that the received signal results in considerably reduced fading. Receiver diversity is equal to the number of independent fading branches i.e. almost equal to the number of receive antennas.

#### - *Transmit Diversity*

Transmit diversity can be used where multiple transmit antennas are present at the transmitter side, the transmit antennas are placed adequately apart from each other. Information to be transmitted is processed at the transmitter and then spread across the multiple antennas.

### **1.5 Space Time Coding**

Space-time coding (STC) was first introduced by Tarokh *et al.* [12]. Encoder generates space time coded symbols so as to achieve coding gain, diversity gain and high spectral efficiency. Space Time Coding introduces redundancy into a transmission to achieve high reliability, high performance and high spectral efficiency.

Space Time Codes designing aims to find code matrices which satisfy the criteria of optimality [13]. Earlier, the effect of multipath fading in multiple antenna systems was decreased by using diversity techniques such as receiver diversity and frequency diversity.

The main difference between spatial multiplexing and Space Time Coding is as follows:

- 1) Spatial Multiplexing transmits more symbols.
- 2) STC transmits only (at most) 1 reliable symbol/channel use by means of diversity.

Since the remote units are need to be simple, small and inexpensive, it is difficult to efficiently use large number of receiver antennas at the remote units. Therefore, transmit diversity is more popular i.e. multiple antennas are preferred at the base stations. In

construction of Space time codes there is always a tradeoff between maximizing the information rate, simplicity in decoding and error probability.

STCs are basically of two types, Space-Time Block Codes (STBC) and Space-Time Trellis Codes (STTC).

The summary of some of basic and generally accepted STBCs i.e Alamouti Codes, Orthogonal STBC and Quasi-orthogonal STBCs and linear dispersion codes is as follows.

### 1.5.1 Space Time Block Codes

Space Time block codes produce matrix from block of input symbols whose columns represent time and rows represent antennas. The major advantage of Space Time block codes is diversity gain and simple decoding techniques are applicable:

#### 1.5.1.1 Alamouti Codes

It is the simplest class among all space time codes, known as Orthogonal Space Time Block Codes [14]. If  $x_1, x_2$  are the modulated symbols of any real or complex constellation, the transmission is done during 2 symbol periods as follows. Therefore, the average normalized data rate of the Alamouti STC is 1 symbol/period.

**Table 1 Transmission of symbols in two different time periods in Alamouti Technique**

	Tx1	Tx2
T	$x_1$	$x_2$
t+T	$-x_2^*$	$x_1^*$

In the first transmission period symbols  $x_1$  and  $x_2$  are transmitted simultaneously from both antennas TX1 and TX2 respectively. During the second transmission period, the symbol  $-x_2^*$  is transmitted from antenna TX1 and the symbol  $s_1^*$  from TX2.

Hence encoding is done in both time domain because two transmission periods and space domain because there are two transmit antennas. The code matrix is orthogonal it allows receiver to detect symbols by linear processing. The received signals at t and t+T are as follows:

$$y_1 = h_1x_1 + h_2x_2 + n_1 \text{ (First time slot)} \quad (16)$$

$$y_2 = h_1 x_2^* + h_2 x_1^* + n_2 \text{ (2<sup>nd</sup> time slot)} \quad (17)$$

where  $n_1$  and  $n_2$  are complex random variables due to additive white Gaussian noise and interference. This can be written in matrix form as:

$$y = H x + n \quad (18)$$

Where  $H = [h_1, h_2]^T$  is the complex channel vector and  $n$  is the noise vector at the receiver.

Alamouti extended this diversity coding scheme to the case when there are 2 transmit antennas and  $m$  receive antennas, it was proved that the scheme provided a diversity order of  $2m$ . It is proved in [15] that using conventional orthogonal design of STBC that full diversity and full transmission rate is not possible for more than two transmit antennas.

### 1.5.1.2 Generalized OSTBC

After the use of Alamouti Codes for 2X2 MIMO, further investigations were carried out to determine the antenna configurations for which OSTBCs can be constructed. It was proved that OSTBC exist for only few antenna configurations [15] i.e. for example for PAM square OSTBC exist only for 2, 4 or 8 transmit and receive antennas. For non square OSTBC i.e when number of transmit and receive antennas are not equal, OSTBCs can be designed for any number of transmit antennas using Hurwitz-Radon coding theory [16].

For complex valued constellations for e.g. PSK among all OSTBC only Alamouti codes can achieve full diversity determined by maximum negative slope for BER curve at higher SNR and full rate. For more than two transmitter antennas using OSTBC the diversity gain is improved but rate decreases to  $\frac{3}{4}$  or below. Hence the major drawback of OSTBC is tradeoff in diversity gain and data rate. Hence OSTBC was inefficient for the MIMO applications which require high data rate STCs.

### 1.5.1.3 QOSTBC

The applications for which full rate i.e. 1 symbol/sec is major requirement whereas full diversity was not major requirement Quasi-Orthogonal STCs were developed [17] for more than two antennas. Several such QOSTBCs have been designed and characterized [18]. In quasi-orthogonal code designs, the columns of the transmission matrix are divided into groups. The different groups of transmission matrix are orthogonal to each other whereas the columns within the group are not orthogonal to each other. Since diversity gain in QOSTBC

is less than other OSTBC hence slope of BER curves is less at high SNRs. Now a days, research is focused on improvement in BER performance by constellation rotation and manipulation [19-20]. During decoding pair of symbols are decoded independently and because of coupling between the estimated symbols, it results in loss of diversity

#### 1.5.1.4 Linear Dispersion Codes

Linear Dispersion Codes is space–time transmission scheme that exhibits coding and diversity gains of previously designed space time block codes and capacity gains i.e. higher data rates like V-BLAST for any number of transmit and receive antennas. Using this high rate data is divided into smaller sub streams and their linear combinations are transmitted over space and time [21]. These designed codes maximize the mutual information between the transmitted and received signals. These codes work with arbitrary numbers of transmits and receive antennas. The data divided into substreams are dispersed in linear combinations over space and time, therefore these are known as Linear Dispersion Codes. The transmitted signal can then be written as a  $T \times M$  matrix  $S$  that governs the transmission over the  $M$  antennas during the interval. Assume the data sequence is been broken into  $Q$  substreams and  $S_1, S_2, \dots, S_Q$  are the complex symbols chosen from an arbitrary, say  $r$ -PSK or  $r$ -QAM, constellation. Mathematically Linear-dispersion (LD) coded symbol is given by

$$S = \sum_{q=1}^Q (s_q C_q + s^*_{q} B_q) \quad (19)$$

$$S = \sum_{q=1}^Q (\alpha_q A_q + j\beta_q B_q) \quad (20)$$

Where the real scalars  $\{\alpha_q, \beta_q\}$  are determined by:  $S_q = \alpha_q + j\beta_q$ ,  $q=1, 2, \dots, Q$

Where  $A_q = C + D$ ,  $B_q = C - D$

The ultimate rate of the code depends on the number of signals sent  $Q$ , the block length of the code  $T$ , and the size of the constellation from which  $S_1, \dots, S_q$  are chosen. If the constellation is  $r$ -PSK or  $r$ -QAM. Rate is given by

$$R = \frac{Q}{T} \log_2 r$$

The proposed scheme has the following characteristics [22]:

- These codes are special cases of both V-BLAST and the block codes .
- The performance of LDC's generally better than both both spatial multiplexing and diversity coding i.e. it combines advantages of both techniques.
- These can be designed for any number of transmit and receive antennas.
- Very simple to encode.
- Due to linear structure, these Can be decoded in a variety of ways.i.e simple linear-algebraic techniques such as Successive nulling and canceling (V-BLAST ), square-root V-BLAST, Sphere decoding .
- These are high rate codes i.e. satisfy the information-theoretic optimality criterion.

### **1.5.1.5 Linear Orthogonal Dispersion Codes**

Linear Dispersive Codes are a kind of codes that aims to provide both high spectrum efficiency and high reliability by maximizing mutual information between transmitter and receiver. But their good error probability performance is not strictly guaranteed. The bit error rate performance can be further enhanced by using Linear Orthogonal Dispersion Codes. Linear orthogonal dispersive codes are based on orthogonal vector set and their design joint optimizes the outage capacity and error probability performance [23].

Linear Orthogonal dispersive codes have been design by several approaches. Here Linear Dispersive codes are designed by orthogonal vector method. Each sub stream of data is multiplied with the orthogonal vector set. The orthogonal vector set is given by

- (1) Find a rand  $N \times N$  matrix  $R$  and its singular decomposition  $R = U \Sigma V$  where  $V$  is a  $N \times N$  matrix with its column orthogonal to each other
- (2) Multiply the substream of data with orthogonal vector  $V$  set to make data streams orthogonal.

The outage probability of LODC is lesser than the outage probability of LDC.

### **1.6 Capacity and Diversity trade off**

Space-time codes create redundancy by spreading data symbols in time and space, which improves reliability by decreasing bit error rates (BER) but does not improve capacity. Spatial multiplexing improves capacity as this technique decomposes the channel matrix into sub channels but the resulting system is not optimized in terms of BER. Hence there is

tradeoff in terms of capacity and diversity [24]. The capacity and diversity gains tradeoff was described by Tse and Zheng in [24], that in a given MIMO channel, higher capacity can be achieved by reducing diversity gain and vice versa.

Linear dispersion code design for MIMO system is proposed to bridge the gap between multiplexing and diversity as the performance of these codes is better in terms of ergodic capacity as well as error probability.

As with the increase in number of transmitter antennas ergodic and outage capacity increases i.e. data rates increases. LTE-advanced for 4G aims to use 8x8 MIMO and 128 QAM and promises to deliver 1Gbits/s for fixed users and 100Mbits/s to mobile users [25]. At very high rates and with a large number of antennas, these space–time codes suffer from complexity or performance difficulties. The number of states in the trellis codes grows exponentially as rate and number of transmit antennas grow [26]. The block codes suffer from rate and performance loss as the number of antennas grows, and the codes suffer from decoding complexity if the rate is too high. V-BLAST can handle high data rates with less complexity but the decoding scheme used does not work when number of receiver antennas are lesser than number of transmit antennas.

Linear Dispersion Codes (LDCs) spread data symbols using dispersion matrices and can be designed for any arbitrary numbers of transmit and receive antennas. These codes exhibit both high spectral efficiency good error performances. Hence for both higher data rates and diversity gains simultaneously Linear Dispersion codes are used for 8X8 MIMO in the thesis.

## **1.7 Precoding**

Now a days popular research field in wireless communication theory is precoding i.e. using channel information at transmitter. Precoding occurs when information about the wireless environment is acquired at the transmitter. CSI can be obtained through receiver –to-transmitter feedback or transmitter-based channel estimation. Precoding is an important tool in system design, since the use of channel knowledge of any kind at the transmitter can significantly improves spectral efficiency [27] hence it optimizes symbol error rates (SER) and BER performance.

Precoding techniques are classified according to the type of channel information present at the transmitter.

### **A. Channel Mean Precoding**

Precoding is costly to include in a design. In order to precode, the transmitter must have access to some knowledge about the channel's structure, and this can be expensive to acquire in terms of system resources. The simplest type of precoder, known as a mean feedback precoder, requires that the transmitter always know the instantaneous channel realization, or channel mean  $H$ . Usually, this channel mean information is acquired through a feedback path from the receiver to transmitter, where the receiver is assumed to have estimated the channel [28]. The noise term which corrupts the transmitter's channel mean estimate reflects the uncertainty in the channel estimate. This uncertainty can arise due to channel estimation errors, errors induced by the feedback channel, and channel variations due to the feedback delay.

### **B. Channel Covariance Precoding**

Instead of the receiver sending back an estimate of the channel mean to the transmitter, it only sends back the channel correlation matrices  $R_R$  and  $R_T$ . In this way, the transmitter models the MIMO channel as being a complex Gaussian matrix with zero mean and covariance matrix given by  $R_{MIMO}$  [29].

Covariance feedback significantly reduces the volume of information on the feedback channel. Since channel estimates are not required at the transmitter, the channel can be rapidly time varying and this does not require additional feedback. As long as the statistics of the channel are assumed to be constant over lengthy time duration, a realistic assumption in some wireless channels, the transmitter can withstand rapid variations in  $H$ . Therefore, the coherence time of the channel is not a concern as in the case of channel mean precoding. A quantity of greater interest is the statistical coherence time, the time over which the channel statistics are assumed constant.

Because it imposes less strict requirements on the channel's time variation, channel covariance feedback has increased in popularity as a plausible method of improving the capacity and error rates of systems characterized by correlated channels.

The transmitter is said to utilize channel mean information if channel's instantaneous value with slight noise term is known. If the transmitter is only able to characterize the covariance matrix at the transmitter and receiver, then the precoder is said to utilize channel covariance

information. Transmit channel side information (CSIT) is information about the channel known at the transmitter. It is multilayer beamforming in a narrow sense or all spatial processing at the transmitter in a wide sense. In case of multiple antennas at the receiver, the transmit beamforming cannot maximize the signal level at all of the receive antennas simultaneously, therefore precoding is used.

## **1.8 Channel Coding**

Reliable transmission of signals from transmitter to a receiver is the major concern in today's communication systems. While transmission through the channel the signals are corrupted. Channel coding is used to minimize the distorting effects of channel and noise and maximize the information sent through the channel. Channel coding deals with error control techniques. If the data received at the end of a communications system contains errors that are too frequent for the desired use, these errors can regularly be reduced by the use of a number of techniques.

The one commonly used is Automatic Repeat Request (ARQ), in which the recipient checks the transmission for errors and asks for retransmission if any error occur. This is also known as sometimes backward error correction. Second used is Channel coding, is a forward error correction (FEC) technique. In this technique the bits are prepared for transmission using a special algorithm known as an error-correcting code, which is then decoded on the receiving end. Both methods are also often used in a hybrid manner, and allow repairing of small errors in the transmission with a channel code, whereas major errors requires a complete retransmission.

FEC tries to find out the errors and correct them . However, ARQ just finds out the error and sends request to the transmitter to resend. The FEC-based methods are more complex as compared with ARQ.

This process require extra bits i.e. parity bits are allocated, it results in reliable connection but extra consumption of extra bandwidth. Among all the existing error correction codes, convolutional codes are the most commonly used channel codes in practical communication systems. These codes are developed with a separate strong mathematical structure and these are primarily used for real time error correction.

### 1.8.1 Convolution Encoding

Elias was the first to introduce Convolutional codes in 1955 as a substitute to block codes. Convolutional codes are different from block codes as the encoder contains memory and the output of the encoder at any time unit depend not only on the  $k$  inputs but also on  $m$  previous input blocks. Convolutional codes are generated by passing the information sequence to be transmitted through a linear finite-state shift registers.

A Convolution code is defined by three integers:  $n$ ,  $k$  and  $K$ , where the proportion  $k/n$  is termed code rate,  $n$  is the number of output bits,  $k$  is the number of input bits and  $K$  is called constraint length. The constraint length signifies the number of  $k$ -bit shifts over which a single information bit can influence the encoder output.

For example: Consider the binary convolution encoder with constraint length  $K=3$ ,  $k=1$  and  $n=3$  as shown in figure. The generator matrices are:  $\mathbf{g}_1=[100]$ ,  $\mathbf{g}_2=[101]$ , and  $\mathbf{g}_3=[111]$ . The generators are represented conveniently in octal forms as (4,5,7).

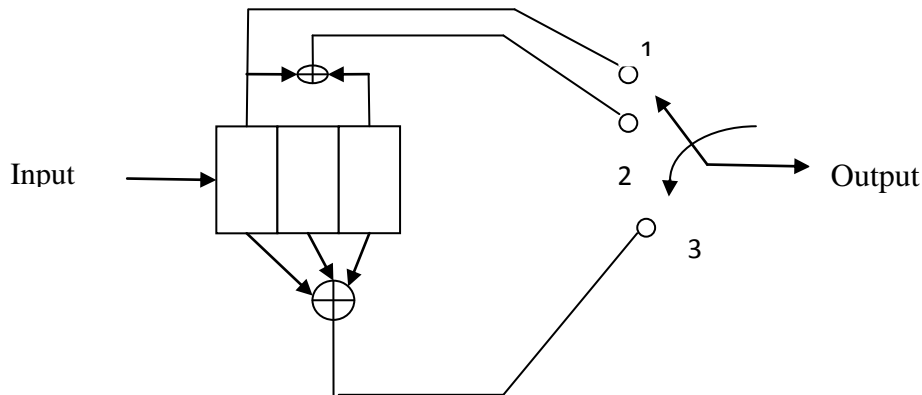

**Fig. 1.5 Convolution encoder with  $K=3$ ,  $k=1$ ,  $n=3$**

### 1.8.2 Puncturing

The process of removing additional parity bits is known as puncturing. Some ability to correct errors will be lost by puncturing. But the process allows a trade-off between the number of bits added, and the resulting ability of the code to correct errors and the transmission requirements in

terms of number of bits.

For example If we have to send two bits, the code will thus generate eight output bits. However, if a  $2/3$  puncturing is used, only three output bits will be generated instead of eight for the two input bits. This made clear in the following: Two input bits is given to convolution encoder. Output bits 1, 2, 3, 4, 5, 6, 7, 8 ( $2/8$  without puncturing).

But id puncturing is used eight output bits of convolution encoder are converted to three output bits i.e. output bits 1, 2, , , 5, , , (with  $2/3$  puncturing)

Decoding is done by the Viterbi Algorithm with slight modification that the missing code bits are replaced with don't care bits while decoding.

### **Organization of Thesis**

The thesis is organized into six chapters. Chapter 1: introduces the MIMO system and brief idea of spatial multiplexing, precoding, Space Time Codes, precoding and convolution encoding. Chapter 2: Discusses the literature survey of Coding Techniques in MIMO systems. Chapter 3: Introduces to the Gaps and objectives of the study. Chapter 4: Introduces Precoding using Channel State Information and BER analysis of Precoded linear dispersion codes in 8X8 MIMO and BER analysis of Convolution encoded and bit interleaved linear dispersion codes in 8X8 MIMO. Chapter 5: Simulation of MIMO (8x8) BER results. Chapter 6: Provides a Conclusion and gives recommendations for future study.

## CHAPTER 2

### LITERATURE REVIEW

---

The wireless era began around 1897 when Guglielmo Marconi first established a radio link to provide continuous contact with ships sailing the English Channel. Since then, mobile systems have developed and spread considerably. The use of wireless systems increased rapidly in the 1950's and 60's, when the number of users largely exceeded the small number of channels available. This trend showed a clear need for larger capacity as well as better roaming flexibility. One of the ideas to improve spectral efficiency and reliability was use of Multiple transmit and receive antennas.

**L.H. Brandenburg *et al.*** [30] gave the initial ideas in the field of MIMO in 1973's. They derived formula on the capacity of multiple input, multiple output linear channel with memory, and additive white Gaussian noise. It was analyzed that the channel to which this formula is applicable, the capacity and signal to noise ratio are linearly related. Jack Salz and Jack Winters published several papers on beam forming applications at Bell Laboratories in 1984 and 1986.

Many MIMO techniques were been proposed targeting at different scenarios in wireless communications

**H.Foschini *et al.*** [31] investigated the capacity of a multiple antenna point to point wireless system in a narrow-band slowly Rayleigh-fading channel. The fading was supposed to be independent and identically distributed (i.i.d.) fading at different antenna elements, and the channel is not known at the transmitter while the receiver tracks the channel perfectly. With T transmit and R receive antennas, the system is described by the matrix equation

$$Y = \sqrt{\frac{E_s}{T}} Hx + n \quad (21)$$

$E_s$  is the total energy available at the transmitter, Y is the R x 1 vector of received signals on the R antennas, x is the T x 1 vector of transmitted signals on the T transmit antennas, n is the R x 1 noise vector consisting of independent complex AWGN distributed elements with

zero mean and variance  $\sigma^2$ , and  $H$  is the RxT channel matrix. The capacity of this system is given by

$$C = \log_2 E_H \left[ \det \left( I_n + \frac{\rho}{T} H H^H \right) \right] \quad (22)$$

Where,  $\rho = \frac{E_s}{\sigma^2}$

Where  $E_H\{.\}$  denote the expectation over  $H$ , and the operator indicates the hermitian of the matrix  $H$ .

**G. J. Foschini** [32] invented layered architecture that could realize greater capacity as promised in information theory. The Bell-Labs Layered Space Time (BLAST) system is a layered space-time architecture originally proposed by Bell-Labs to achieve high data rate wireless transmissions. Different symbol streams are transmitted simultaneously from all transmit antennas i.e. the streams overlap in frequency and in time. The receiver antennas via signal processing recover the signal form the superposition of all received symbol streams.

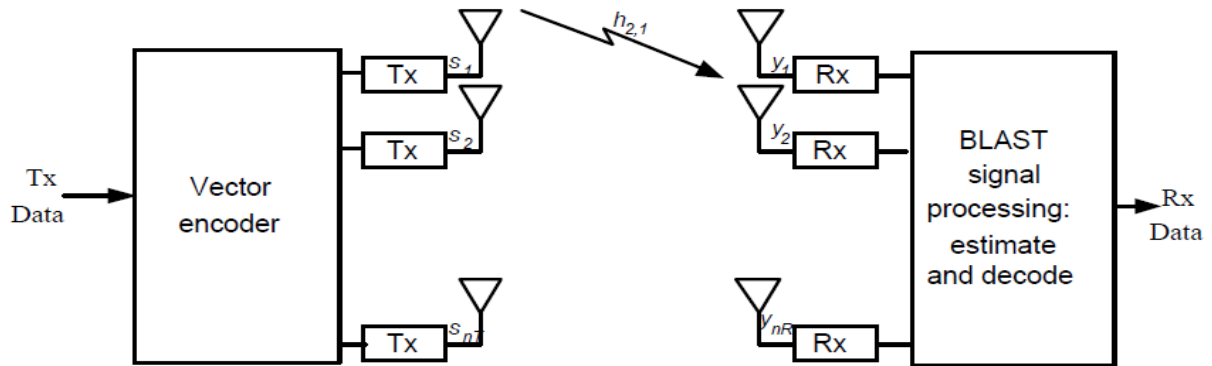

**Fig. 2.1 Schematic representation of BLAST system**

The BLAST technique had two major drawbacks:

- (1) It requires  $N_r \geq N_t$  i.e. requires number of receiver antennas always greater than number of transmitter antennas hence is not always feasible when the receiver is a small.

(2) The performance of layered architecture in BLAST decoding algorithms was limited by error propagation.

**Vahid Tarokh *et al.*** [33] proposed realization of transmit diversity, known as space–time trellis coding in 1998. STTC is mainly defined in terms of trellis tree and known as trellis-coded modulation (TCM) code. In STTC multiple transmitter antennas transmit all the output code symbols at each time simultaneously as a substitute of transmitting the output code symbols serially from a single transmitter antenna as in the traditional TCM scheme. Because of set partitioning or constellation partitioning trellis codes achieve high spectral efficiencies and good error rate properties. It was shown that this technology was suitable for high-data-rate wireless communications and presents its performance over a frequency-flat Rayleigh fading channel. It performed well in slowly fading environments, but with the drawback of increase in decoding complexity, that grows exponentially with the number of antennas. It provides both full diversity and coding gain.

**Alamouti** [14] proposed a remarkable Space Time codes with two transmit antennas, which can achieve the minimum BLER with the use of a decoder with much less complexity for MIMO systems. But this has limitation of only 2 transmitter antennas. The inherent orthogonality was the essential feature of these schemes which guaranteed linear decoding that provides the maximal likelihood result.

**H. Jafarkhani** developed Quasi–Orthogonal STCs [34] for the applications for which full rate i.e. 1 symbol/sec is major requirement whereas full diversity was not major requirement for more than two antennas. In quasi-orthogonal code designs, the columns of the transmission matrix are divided into groups. The different groups of transmission matrix were orthogonal to each other whereas the columns within the group were not orthogonal to each other. In the proposed codes instead of single symbols, the decoder works with pairs of transmitted symbols. During decoding pair of symbols are decoded independently and because of coupling between the estimated symbols, it results in loss of diversity.

**Da-Shan Shiu *et al.*** [16] investigated the effects of fading correlations in multi element antenna systems. The studies showed that if connecting pairs of transmit and receive antenna elements fades independently, identically distributed, multi element antenna systems grant a large increase in capacity as compared to single-antenna systems. An MEA system can be described in terms of spatial Eigen modes, which are single-input single-output sub channels.

The channel capacity of an MEA is the sum of capacities of these sub channels. They showed that the fading correlation affects the MEA capacity by modifying the distributions of the gains of these sub channels. The fading correlation depends on the physical parameters of MEA and the scattered characteristics. They employed an abstract model, which is appropriate for modeling narrow-band Rayleigh fading in fixed wireless systems.

**Babak Hassibi *et al.*** [35] proposed codes are high rate Linear Dispersion Codes and they have both capacity and diversity optimality. These proposed high-rate coding scheme could be used to for any configuration of transmit and receive antennas. Both V-BLAST and many proposed space-time block codes are subsumed as special cases. This scheme data into substreams of data and transmit data in linear combinations over space and time. The code construction is done such that the mutual information between the transmitted and received signals is optimized. The codes have linear structure, as the codes retain the decoding simplicity of V-BLAST, and they possess many coding advantages.

**Hamid Ebrahimzad *et al.***[36] investigated the diversity-multiplexing tradeoff (DMT) at finite signal to noise ratio for a multiple-input multiple-output (MIMO) channel consisting of two transmitter and two receiver antennas ( $2 \times 2$  MIMO). To show trade off the outage probability of the mutual information between transmitter and receiver vs. SNR is extracted. It has been made clear by analysis that the at operational SNRs attainable diversity gains are considerably lower than asymptotic values for SNR tends to  $\infty$ . Hence this paper provided a useful tool to show the diversity-multiplexing trade-off at the  $2 \times 2$  MIMO system in practical (finite SNR) situation.

**Yonghua Li *et al.*** [37] state that in mobile communication, space is a very important domain to use. Two kinds of leading techniques are beamforming and STBC in MIMO system. They investigated the relation between beamforming and STBC for the capacity perspective. The performance of the system is improved by both techniques at the cost of reduction in capacity, hence the channel matrix is converted into scalar AWGN by these techniques. In independent MIMO channel at low SNRs, the MIMO capacity is less than that of beamforming system whereas the capacity of beamforming is larger than that of MIMO system, and MIMO capacity is same with that of STBC in highly correlated channel. It has been proved that at both independent and correlated channels, beamforming is robust. It had

been made clear that in case of code rate one over a channel of rank one STBC is optimal with respect to capacity. Simulations were conducted at the actual applications.

**Teletar *et al.*** [9] proposed that when the (CSI) is available at the transmitter, the capacity given can be increased by given the transmitted power to various antennas according to the “water-filling” algorithm. In the case of water pouring principle the channel parameter are known to transmitter and more power is given to that channel which is in good condition or less or none which is in bad condition

$$C = E_H \left( \int_{i=1}^k \log_2(\mu \lambda_i)^+ \right) \quad (23)$$

$\mu$  is chosen

$$\rho = \sum_{i=1}^k (\mu - \lambda_i^{-1})^+ \quad (24)$$

+ denotes the positive term.

**Enis Akay** [38] analyzed Bit Interleaved Coded Modulation Beam forming (BICMB) in 2007. BICMB makes use of the channel state information at the transmitter and the receiver. By using CSI BICMB achieves full spatial multiplexing and maintains full spatial diversity of NM over N transmit and M receive antennas. The considerable performance gains may be limited with channel estimation errors and limited feedback whose but still significantly more gains than conventional systems.

**Constantin Siriteanu *et.al*** [39] studied the zero-forcing (ZF) detection for multiple-input multiple-output (MIMO) wireless communications systems and transmit-correlated and estimated Rician fading with realistic azimuth spread (AS) and  $K$ -factor .

**Frederik Simoens *et.al*** [40] investigated linear precoding for bit-interleaved coded modulation (BICM) using additive white Gaussian noise (AWGN) channels. Linear precoder is concatenated with outer convolutional encoder which produces a powerful code with a limited decoding complexity. For a binary phase-shift keying (BPSK) signal set, the optimal precoders that result from these rules are also derived. Numerical results confirm the analytical findings and simulations illustrate the effectiveness of the approach. They showed that a precoder is suboptimal for BPSK when non iterative receiver is used.

**Karl Werner *et.al*** [41] evaluated the potential link performance gains of higher order MIMO up to 8×8 according to LTE Rel. 10 in 2012, which is known as LTE-Advanced, in a

field measurement campaign using a test bed implementation. It was noticed that increasing the transmit and receive antennas from  $1 \times 2$  (Tx×Rx) MIMO up to  $8 \times 8$  MIMO enhanced the significant throughput gains in each step.

**L.C Wood *et.al*** [42] examined delay in receiving transmitted data at the receiver that results in the loss in throughput. The performance benefits of MIMO antenna systems in increasing the throughput of a communication system depends on the type and quality of the information sent to the transmitter. They investigated the effect on the throughput when the channel has a delayed channel matrix estimate, as well as when delayed channel statistical information is provided. Additionally, the effect of both delayed transmit and receive channel state information is explored. The performance is examined using measured data in several environments.

**Christoph Windpassinger *et.al***[43] investigated precoding for MIMO systems including multiple-antenna and multiuser systems. It was made clear that nonlinear preequalization offered considerable advantages over linear preequalization that results in increase in average transmit power. Besides it outperforms decision-feedback equalization at the receiver side which suffers from problem of error propagation if joint processing at the receiver side is possible. If it is not possible to receive perfect CSI at the transmitter, precoding can be done by average channel knowledge. Linear adaptive residual equalization can be used at the receiver to compensate the mismatch of precoder and actual channel realization.

**Shengli Zhou *et.al***[44] investigated that it is not possible to know channel knowledge perfectly at the transmitter, hence based on channel mean value knowledge designed a multiantenna transmitter. The transmitter design given is eigen beam former with multiple beams pointing to orthogonal directions along the eigenvectors of the correlation matrix of the estimated channel at the transmitter and with proper power loading across beams.

This technique is capable of achieving the best performance in a large range of transmit-power-to-noise ratios, without a rate penalty when there are multiple receiver antennas with considerably good feedback quality.

## CHAPTER 3

### GAPS AND OBJECTIVES

---

#### Gaps

- The space-time codes have disadvantage of complexity and degraded performance when used with a large number of antennas and higher rates.
- There is exponential growth in the number of states in the trellis codes with either the rate or with the number of transmit antennas.
- BLAST can handle high data rates with less complexity with the use of all the available sub channels i.e. spatial multiplexing. The major drawback in BLAST is that there is no attempt to reduce error rates. Hence there is capacity and diversity gain trade off.
- LDC is space-time transmission technique that has many coding and diversity advantages of previously designed codes. LDCs are derived with an assumption that the transmitter has no knowledge of the wireless environment. Hence LDC designs are not optimal because they do not utilize any knowledge of the channel in their design.
- With the increase in number of transmitter and receiver antennas there is increase in channel capacity and reduction in BER, but with increase in RF link. More power is required for more number of transmitter and receiver.

#### Objectives of Thesis

In the recent version of LTE-Advanced i.e. 4G, the downlink peak data rate requirement is targeted upto 1Gbps 100 Mbps for stationary users [3-4]. The most efficient way to reach higher data rates in these days is the use of large antenna arrays up to eight stream (8X8) MIMO. Aim is to use efficient coding technique that can ensure higher data rates and less symbol errors at receiver i.e. both capacity and diversity gains for large number of transmitter and receiver antennas.

Primary objectives of this thesis are:

- ❖ To study and simulate the uncoded MIMO (8X8) System Capacity and Bit Error Rate.
- ❖ To study and analyze the capacity gain and BER performance of MIMO (8x8) using Linear Dispersion Codes and Precoded Linear Dispersion Coded in Rayleigh channel.
- ❖ To mitigate the channel errors and outage at higher SNR's proposing Convolution Encoder and Interleaver in Linear Dispersion Codes coded 8X8 MIMO.

## **METHODOLOGY**

Need of next generation wireless systems i.e. 4G is to provide reliable and high data rate communication. Since Linear Dispersion Codes are high rate codes and these bridges the tradeoff between the capacity and diversity gain and diversity gain. The aim was to get high rate hence Linear Dispersion codes are used in 8X8 MIMO systems. Since using channel state information at the transmitter improves the bit error performance, eigen beamforming is used in Precoded Linear Dispersion coded 8X8 MIMO Systems.

In order to combat the effect of burst errors introduced by channel, channel coding is proposed in the existing system using convolution encoder at the transmitter. Use of convolution encoder at the transmitter reduces outage probability hence reduces symbol error rates.

## CHAPTER 4

### **8X8 MIMO Using Precoded Linear Dispersion Codes And Convolution Encoding**

---

In order to fulfill the requirement of outstanding reliability and exceptionally high capacity the most promising technique is to use Multiple Input, Multiple Output (MIMO) systems with large number of antennas is used at the transmitter and receiver. In 4G LTE-advanced aims to use 8x8 MIMO system in order to achieve data rates of 1Gbits/s at fixed speeds and 100Mbits/s to mobile users. Higher system level spectral efficiency is also of great importance for B4G in parallel with the race for ever increasing peak data rates. Diversity coding techniques adds redundancy in order to enhance spectral efficiency and reduce error rates [4].

We have considered a MIMO system with transmit array of  $N_t$  antenna and receive array of  $N_r$  antenna. The transmitted matrix is  $N_t \times 1$  column matrix  $X$  where  $X_i$  is  $i$ th component which is transmitted from  $i$ th antenna. We suppose the channel Rayleigh fading i.e. multipath transmission takes place. The channel matrix  $H$  is a  $N_t \times N_r$  complex matrix. The component  $h_{i,j}$  of the matrix is the fading coefficient from  $j^{\text{th}}$  transmit antenna to  $i$ th receive antenna [7].

#### **4.0 8X8 MIMO SYSTEM MODEL**

Assume 8 transmit and 8 receive antenna case, resulting in a 8x8 MIMO channel. The channel is assumed to be flat fading Rayleigh multipath channel i.e. the signal is assumed to be scattered between the transmitter and the receiver and the modulation technique used is 8-QAM. When the signals reach the receiver, the overall signal is a combination of all the signals that have reached the receiver via the different paths that are available. The power of the received signal varies randomly according to the Rayleigh distribution. Rayleigh fading is also known as small scale fading because all the transmitted multipath components are non Line of Sight components as there is no Line Of Sight Propagation in Rayleigh fading.

#### 4.1 Uncoded 8×8 MIMO System Model

Here 8X8 MIMO system takes advantage of the spatial diversity that is obtained by spatially separated antennas in a dense multipath scattering environment. In spatial multiplexing of data system in 8X8 MIMO, the symbols are split and are transmitted without any diversity coding results in higher rates but poor symbol error performance. In case of 8×8 MIMO channel, the usage of the available 8 transmit antennas for spatial multiplexing can be done as follows:

1. Consider a transmission sequence X, for example  $\{x_1, x_2, x_3, \dots, x_n\}$ .
2. For normal transmission i.e. single transmitter antenna,  $x_1$  will be sent in the first time slot,  $x_2$  in the second time slot,  $x_3$  and so on.
3. However, as there are 8 transmit antennas; we may group the symbols into groups of eight. In the first time slot, send  $x_1, x_2, x_3, x_4, x_5, x_6, x_7, x_8$  from the first and second, third, fourth, fifth, sixth, seventh, eighth antenna, In second time slot,  $x_9, x_{10}, x_{11}, x_{12}, x_{13}, x_{14}, x_{15}, x_{16}$  the first and second, third, fourth, fifth, sixth, seventh, eighth antenna.
4. The grouped eight symbols are sent in one time slot.
5. This forms the simple explanation of a probable MIMO transmission scheme with 8 Transmit antennas and 8 receive antennas.

In case of 8 transmitter and 8 receiver antennas the QAM modulated symbols are transmitted in the following manner

**Table2 Transmission of symbols in two different time periods in spatial multiplexing**

	T1	T2	T3	T4	T5	T6	T7	T8
1 <sup>st</sup> Time Slot	X1	X2	X3	X4	X5	X6	X7	X8
2 <sup>nd</sup> Time Slot	X9	X10	X11	X12	X13	X14	X15	X16

Where T denotes the transmitter and  $X_i^s$  denotes the QAM modulated Symbols.

In this case, 64 channels are involved in every time slot whose channel impulse responses follow flat faded Rayleigh distribution. The multipath structure of the channel is such that the spectral characteristics of the transmitted signal are preserved at the receiver but the strength

of the received signal changes with time due to fluctuations in the gain of the channel cause by multipath propagation.

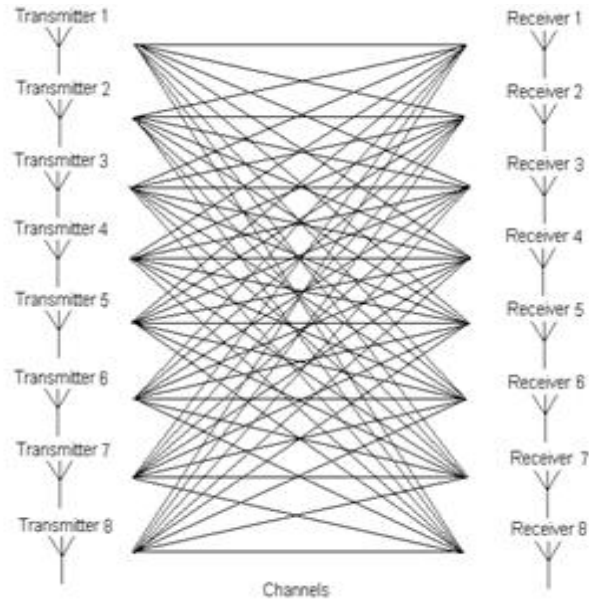

**Fig. 4.1 8X8 MIMO system**

$$y_1 = h_{1,1}x_1 + h_{1,2}x_2 + h_{1,3}x_3 + h_{1,4}x_4 + h_{1,5}x_5 + h_{1,6}x_6 + h_{1,7}x_7 + h_{1,8}x_8 + n_1$$

$$= [h_{1,1} \quad h_{1,2} \quad h_{1,3} \quad h_{1,4} \quad h_{1,5} \quad h_{1,6} \quad h_{1,7} \quad h_{1,8}] \begin{bmatrix} x_1 \\ x_2 \\ x_3 \\ x_4 \\ x_5 \\ x_6 \\ x_7 \\ x_8 \end{bmatrix} + n_1 \quad (25)$$

$x_1, x_2, x_3, x_4, x_5, x_6, x_7, x_8$  are the transmitted symbols and  $n_1, n_2, n_3, n_4, n_5, n_6, n_7, n_8$  is the noise on 1<sup>st</sup>, 2<sup>nd</sup>, 3<sup>rd</sup>, 4<sup>th</sup>, 5<sup>th</sup>, 6<sup>th</sup>, 7<sup>th</sup>, 8<sup>th</sup> receive antennas. We assume that receiver knows  $h_{1,1}, h_{1,2}, h_{1,3}, h_{1,4}, h_{2,1}, h_{2,2}, h_{2,3}, h_{2,4}, h_{3,1}, h_{3,2}, h_{3,3}, h_{3,4}, h_{4,1}, h_{4,2}, h_{4,3}, h_{4,4}$ . The above equation can be represented in matrix notation as follows:

Equivalently,  $y=Hx+n$

$$\begin{bmatrix} y_1 \\ y_2 \\ y_3 \\ y_4 \\ y_5 \\ y_6 \\ y_7 \\ y_8 \end{bmatrix} = \begin{bmatrix} h_{1,1} & h_{1,2} & h_{1,3} & h_{1,4} & h_{1,5} & h_{1,6} & h_{1,7} & h_{1,8} \\ h_{2,1} & h_{2,2} & h_{2,3} & h_{2,4} & h_{2,5} & h_{2,6} & h_{2,7} & h_{2,8} \\ h_{3,1} & h_{3,2} & h_{3,3} & h_{3,4} & h_{3,5} & h_{3,6} & h_{3,7} & h_{3,8} \\ h_{4,1} & h_{4,2} & h_{4,1} & h_{4,4} & h_{4,5} & h_{4,6} & h_{4,7} & h_{4,8} \\ h_{5,1} & h_{5,2} & h_{5,1} & h_{5,4} & h_{5,5} & h_{5,6} & h_{5,7} & h_{5,8} \\ h_{6,1} & h_{6,2} & h_{6,1} & h_{6,4} & h_{6,5} & h_{6,6} & h_{6,7} & h_{6,8} \\ h_{7,1} & h_{7,2} & h_{7,1} & h_{7,4} & h_{7,5} & h_{7,6} & h_{7,7} & h_{7,8} \\ h_{8,1} & h_{8,2} & h_{8,1} & h_{8,4} & h_{8,5} & h_{8,6} & h_{8,7} & h_{8,8} \end{bmatrix} \begin{bmatrix} x_1 \\ x_2 \\ x_3 \\ x_4 \\ x_5 \\ x_6 \\ x_7 \\ x_8 \end{bmatrix} + \begin{bmatrix} n_1 \\ n_2 \\ n_3 \\ n_4 \\ n_5 \\ n_6 \\ n_7 \\ n_8 \end{bmatrix} \quad (26)$$

## 4.2 8X8 MIMO Using Precoded Linear Dispersion Codes

Linear Dispersion Codes (LDCs) are linear codes that spread modulated data symbols using dispersion matrices. These codes guarantee high spectral efficiency and exhibit good error performance. Design of Linear Dispersion Codes is based on frame theory of wavelets which explicitly optimize both capacity and error performance. LDCs are derived with an assumption that the wireless environment knowledge is not available at the transmitter i.e. LDCs have “worst case design” as they are designed for whatever channel characteristics may be present at any given time. The bit error rate performance of the existing linear dispersion coded system can be improved if Channel State information (CSI) is available at the transmitter through feedback from the receiver, known as precoded linear dispersion codes [29]. In this chapter, Precoded Linear Dispersion Codes (P-LDCs) are proposed which assumes that the receiver and transmitter have perfect knowledge about wireless channel state.

Precoding refers to preprocessing of a transmit signal in order to compensate the channel impairments. If the channel distorts a transmission, the function of a precoder is to pre-distort the transmission so that the serial combination of precoder and channel cancel each other out. The method of precoding used in a system is heavily dependent upon the channel model used in the design.

### 4.2.1 Precoded LDC 8X8 MIMO System Model

The Precoded LDC design uses Rayleigh channel model denoted by  $H$  in combination with linear dispersion matrices to yield codes optimal in capacity and symbol error performance. The assumptions for the channel model and the precoder structure are discussed below.

Suppose there are M transmit and N receive antennas. The Rayleigh fading propagation channel remains constant for time interval denoted by T. The block diagram for the Precoded LDC for 8X8 MIMO is as shown below in the figure. The transmission sequence denoted by X, i.e.  $\{x_1, x_2, x_3, \dots, x_n\}$ , are converted to complex constellation through 8 QAM modulation.

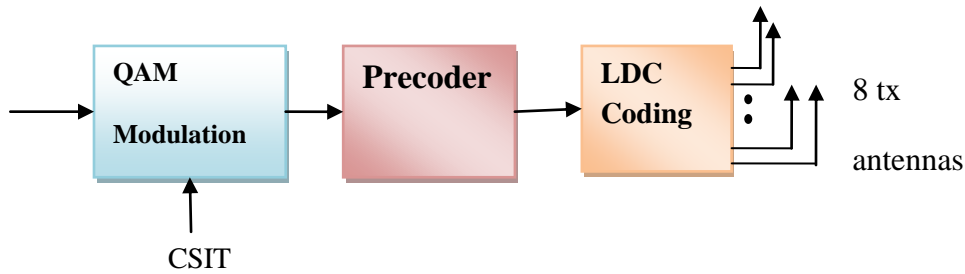

**Fig. 4.2 Block Diagram of Precoded LDC coded 8 antennas MIMO transmitter**

Assuming channel matrix H is known at the transmitter. The precoder processes these symbols before transmission from the antennas. For Precoder matrix, apply a singular value decomposition (SVD) to channel matrix H, it can be expressed as

$$H = U\Sigma V^H \quad (27)$$

Where  $\Sigma$  is the M X N diagonal matrix with singular values of H. U and V are MXM and NXN matrices.

$$m = \min(M, N)$$

$\{\sqrt{\lambda_i}\}_{i=1}^m$  are the main diagonal elements of  $\Sigma$ .

V matrix obtained after applying SVD is used as precoder matrix i.e. before transmission x is multiplied with precoding matrix V.

$$X' = Vx \quad (28)$$

At the receiver side it decodes the noise corrupted signal to recover data bits, treating combination of the precoder and channel as an effective channel.

At the receiver side the received signal y is multiplied by  $U^H$  as:

$$y' = U^H y \quad (29)$$

$$= U^H (U\Sigma V^H X' + n)$$

$$=U^H U \Sigma V^H V x + U^H n$$

$$= \Sigma x + n'$$

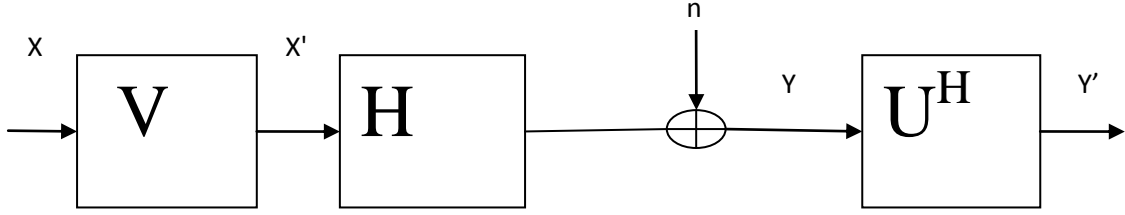

**Fig. 4.3 Block Diagram of Precoder**

Since  $\Sigma$  is diagonal matrix which consists of singular elements hence it results in decoupling of channels. The decoupled received symbols are represented as

$$y'_1 = \sqrt{\lambda_1} x_1 + n'_1$$

$$y'_2 = \sqrt{\lambda_2} x_2 + n'_2$$

$$\vdots$$

$$\vdots$$

$$y'_N = \sqrt{\lambda_N} x_N + n'_N \quad (30)$$

#### 4.2.2 Linear Dispersion Code Construction Model

Consider M transmitter and N receiver antennas i.e. in 8X8 system M=8 and N=8. The Precoded sequence  $X'$  to be transmitted is written as a T X M matrix S that governs the transmission over the M antennas during the interval. Data sequence is broken into Q substreams and  $S_1, S_2, \dots, S_Q$  are the complex symbols chosen precoded 8-QAM modulated constellation and are dispersed using dispersion matrices. Mathematically[21]

$$S = \sum_{q=1}^Q (s_q C_q + s_q^* B_q) \quad (31)$$

$$S = \sum_{q=1}^Q (\alpha_q A_q + j\beta_q B_q) \quad (32)$$

Where the real scalars  $\{\alpha_q, \beta_q\}$  are determined by:  $S_q = \alpha_q + j\beta_q, \quad q=1, 2, \dots, Q$

Where  $A_q = C + D, B_q = C - D$

The design of LD codes depends upon the choices of the parameters T, Q and the dispersion matrices  $\{A_q, B_q\}$ . We assume that  $\alpha_1, \dots, \alpha_q$  and  $\beta_1, \dots, \beta_q$  have variance 1/2 and are uncorrelated. Thus  $S_1, \dots, S_q$  are unit-variance and uncorrelated.

Decoding:

The linearity in the variables  $\{\alpha_q, \beta_q\}$  is the important property of the LD codes which leads to efficient V-BLAST like decoding schemes.

$$X = \sqrt{\frac{P}{M}}SH + V = \sqrt{\frac{P}{M}}\sum_{q=1}^Q(\alpha_q A_q + j\beta_q B_q)H + V \quad (33)$$

Decompose the matrices into their real and imaginary parts to obtain

$$X_R + jX_I = \sqrt{\frac{P}{M}}\sum_{q=1}^Q[\alpha_q(A_{R,q} + jA_{I,q}) + j\beta_q(B_{R,q} + jB_{I,q})X(H_R + jH_I) + V_R + jV_I] \quad (34)$$

Where  $H_R = \text{Re}(H)$  and  $H_I = \text{Im}(H)$

Equivalently

$$X_R = \sqrt{\frac{P}{M}}\sum_{q=1}^Q[\alpha_q(A_{R,q}H_R - A_{I,q}H_I) + \beta_q(-B_{I,q}H_R - B_{R,q}H_I) + V_R]$$

$$X_I = \sqrt{\frac{P}{M}}\sum_{q=1}^Q[\alpha_q(A_{I,q}H_R - A_{I,q}H_I) + \beta_q(-B_{R,q}H_R - B_{I,q}H_I) + V_I]$$

Defining

$$A_q = \begin{bmatrix} A_{R,q} & -A_{I,q} \\ A_{I,q} & A_{R,q} \end{bmatrix}$$

$$B_q = \begin{bmatrix} -B_{I,q} & -B_{R,q} \\ B_{R,q} & -B_{I,q} \end{bmatrix}$$

$$h_n = \begin{bmatrix} h_{R,n} \\ h_{I,n} \end{bmatrix}$$

where  $n = 1, 2, \dots, N$ . Gather the equations in  $X_R$  and  $X_I$  to form the single real system of

equations :

$$\begin{bmatrix} X_{R,1} \\ X_{I,1} \\ \vdots \\ X_{R,N} \\ X_{I,N} \end{bmatrix} = \sqrt{\frac{P}{M}}H \begin{bmatrix} \alpha_1 \\ \beta_1 \\ \vdots \\ \alpha_N \\ \beta_N \end{bmatrix} + \begin{bmatrix} V_{R,1} \\ V_{I,1} \\ \vdots \\ V_{R,1} \\ V_{I,1} \end{bmatrix} \quad (35)$$

where the  $2NT \times 2Q$  equivalent real channel matrix is given by

$$H = \begin{bmatrix} A_1 h_1 & B_1 h_1 & \dots & A_Q h_1 & B_Q h_1 \\ \vdots & \vdots & \ddots & \vdots & \vdots \\ A_1 h_N & B_1 h_N & \dots & A_Q h_N & B_Q h_N \end{bmatrix} \quad (36)$$

The equivalent channel matrix  $H$  is known to the receiver because the original channel  $h$ , and the dispersion matrices  $\{A_q, B_q\}$  are all known to the receiver.

### 4.2.3 Decoding of P-LDC Coded 8X8 MIMO

The decoding is done using Zero Forcing technique. It is a simple and very effective technique for retrieving transmitted data streams at the receiver. The ZF is a linear estimation technique, which inverse the frequency response of received signal. The inverse is taken for the restoration of signal after the channel. This technique requires knowledge of the channel state information (CSI) at the receiver but accurate CSI may not be present at the receiver. In case of Zero Forcing the transmitted symbol is estimated as

$$\hat{X} = \text{pinv}(H) * Y \quad (37)$$

Where  $\text{pinv}$  denotes the pseudo inverse operation and  $\hat{X}$  denotes the estimate of  $X$

$$\text{Pinv}(H) = (H^H H)^{-1} H^H \quad (38)$$

$$\begin{bmatrix} \hat{x}_1 \\ x_2 \\ x_3 \\ x_4 \\ x_5 \\ x_6 \\ x_7 \\ x_8 \end{bmatrix} = (H^H H)^{-1} H^H \begin{bmatrix} Y_1 \\ Y_2 \\ Y_3 \\ Y_4 \\ Y_5 \\ Y_6 \\ Y_7 \\ Y_8 \end{bmatrix} \quad (39)$$

### 4.3 Convolution Encoded and Bit Interleaved linear Dispersion Codes in 8X8 MIMO

Transmission through the channel adds distortion to the transmitted symbols that results in burst errors at the receiver. To diminish the distortion during data transmission in wireless communication systems, channel coding i.e. error control coding is used in communication systems. The mostly used practical technique to handle burst errors is the use of random-error-codes i.e. convolution encoder with a suitable interleaver/ deinterleaver pair.

### 4.3.1 Convolution Encoder

Convolution codes are most widely used among all error control codes. These codes are designed with mathematical structure for real time error correction. Using Convolutional codes the entire data stream is converted into one single codeword and the encoded bits depend not only on the current  $k$  input bits as well as on past input bits of the sequence. The decoding of convolution codes is done using widely used Viterbi algorithm [40]. The system model for convolutional encoded bit stream in LDC coded 8X8 MIMO shown in the fig.4.4.

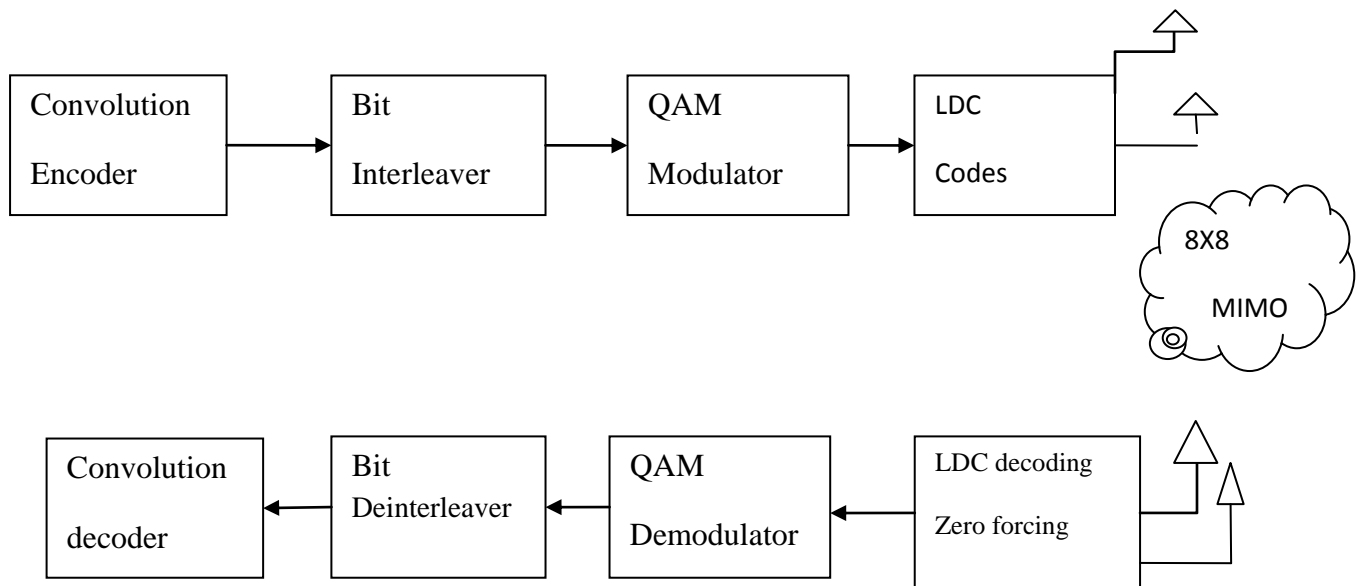

**Fig. 4.4 Block Diagram of 8X8 MIMO System model using convolution encoder**

A Convolution code is defined by three integers:  $n$ ,  $k$  and  $K$ , where the proportion  $k/n$  is termed code rate,  $n$  is the number of output bits,  $k$  is the number of input bits and  $K$  is called constraint length. The constraint length signifies the number of  $k$ -bit shifts over which a single information bit can influence the encoder output. Figure 4.5 shows the architecture of Convolution . Encoder for generator polynomial  $(171,133)$  of code rate  $1/2$ , where  $u_1$  and  $u_2$  are first and second code symbols respectively. Output branch word and input bits to be fed to the register depend on the code rate. Here two bit Output branch word and one bit input are fed to register at each clock cycle.

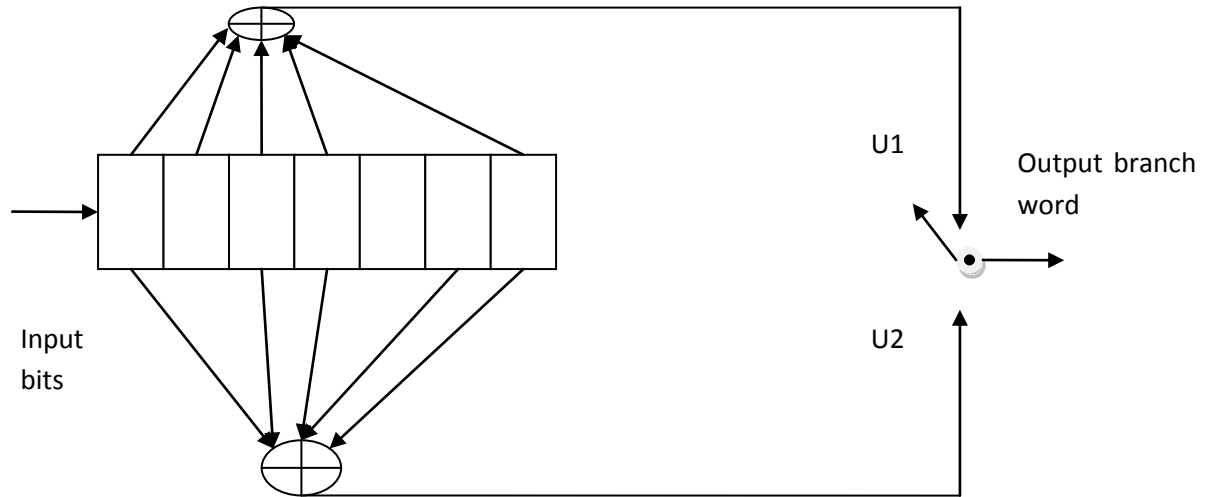

**Fig. 4.5 Architecture of Convolution Encoder for generator polynomial (171,133) of code rate  $\frac{1}{2}$**

At each encoder clock cycle, one message symbol of  $n_a$  message bits is passed into the encoder, which produces one code symbol of  $n_c$  bits. The resulting code word consists of  $N_c$  symbols, with each symbol composed of  $n_c$  bits, and is denoted by  $c=[c_0,c_1,c_2,\dots,c_{N_c-1}]$ . The  $n^{\text{th}}$  code symbol is

$C_n \in [0,1,2,\dots,2^{n-1}]$ . The codeword length is  $N_c = N_a + (K-1)$  symbols, where  $K$  is the constraint length of the code. The union bound of a convolutional code [45] of rate  $k/n$  is

$$P_b \leq \frac{1}{k_c} \sum_{d=d_{\min}}^{\infty} \beta_d \Pr(c \rightarrow \hat{c}) \quad (40)$$

where  $d$  is the Hamming distance (HD) between the correct codeword  $c$  and erroneous codeword  $\hat{c}$ ,  $d_{\min}$  is the minimum HD,  $\beta_d$  and  $\Pr(c \rightarrow \hat{c})$  denote the total number of input error events and pair-wise error probability (PEP) of codeword with Hamming distance  $d$ , respectively.

### 4.3.2 Bit Interleaving

In order to provide diversity in a fading channel error correction coding is used with interleaver to separate adjacent coded symbols farther than the coherence time of fading process. Bit interleaving helps to provide large Euclidean distance between the codewords of

a convolution code. An interleaver is used to rearrange the ordering of a sequence of symbols in a deterministic manner [38]. The aim of an interleaver is to reorder the encoded data. The deinterleaver applies the inverse operation to restore the sequence to its original ordering. The error bursts occurring in the channel or caused by the detector in the receiver can be dispersed by a de-interleaver at the receiver. A random interleaver is used in this system. A pseudo-random permutation is selected, which is assumed to be known both at the transmitter and the receiver. The code symbols are reordered using a psuedo-randomly selected permutation.

Channel encoder mitigates the effect of burst noise due to channel. It has been shown that bit interleaving increases the Euclidean distance between the codewords of a convolutional code. Hence using convolution encoder and bit interleaver at the transmitter, the bit-error-rate (BER) performance of LDC coded 8X8 MIMO system is improved for Rayleigh fading channel over higher SNR.

Hence for higher rates in 4G systems where 8X8 MIMO is used, Linear Dispersion Codes can be used for both capacity and diversity gains. These codes can be designed for arbitrary numbers of transmit and receive antennas. Precoded Linear Dispersion Codes use channel knowledge at the transmitter to modify the design of parameters of LDC so that the spectral efficiency of the system is increased and BER performance is enhanced.

## CHAPTER 5

### RESULTS AND DISCUSSION

---

#### 5.1 Spatial Multiplexed 8X8 MIMO System

In the case of MIMO (8x8) system there are eight antennas at transmitter and receiver. MIMO (8x8) system increases the capacity and reduces the BER. In multiplexing, a high rate signal is broken into multiple lower rate streams and each stream is transmitted from a different transmit antenna in the same frequency channel. Fig 5.1 shows symbol error rate with SNR for 8X8 MIMO system when spatial multiplexing is used i.e.without diversity coding.

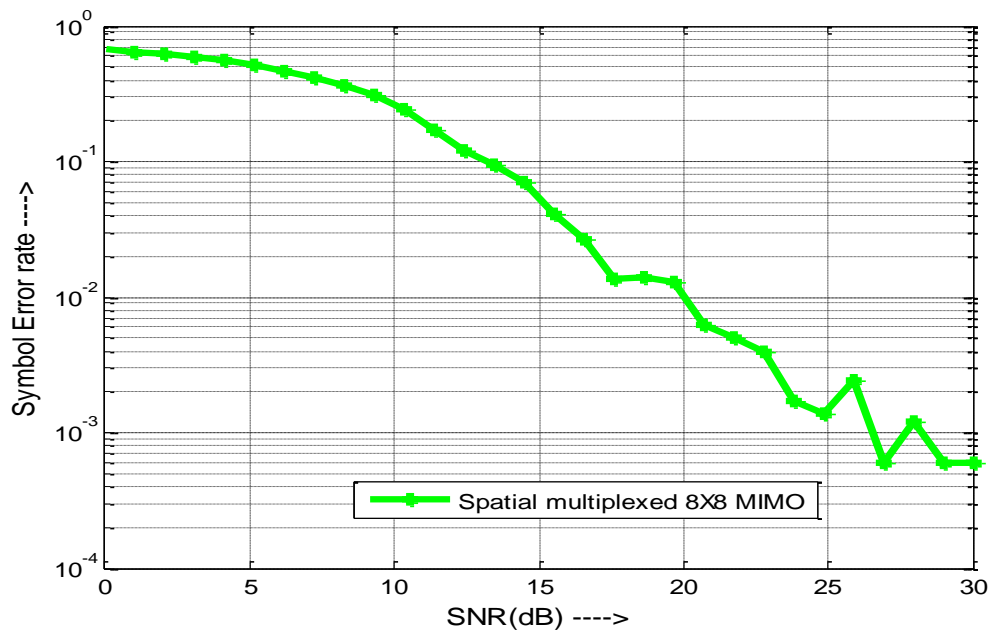

**Fig. 5.1 BER analysis of uncoded 8x8 MIMO System**

Simulation is done using  $M=8$ ,  $N=8$ , 8-QAM modulated symbols are passed through Rayleigh fading channel. Result show that spatial multiplexing results in higher error rates i.e. at SNR of 15dB error rate of  $10^{-1.7}$  is obtained. Zero forcing decoding is done at the receiver side. The ZF is a linear estimation technique, which inverse the frequency response of received signal by multiplying received signal with matrix known as the pseudo inverse for a general  $M \times N$  matrix.

The inverse is taken for the restoration of signal after the channel. Symbol error rate in Multiplexing (8x8) MIMO System is very high.

## 5.2 LDC Coded 8X8 MIMO

In diversity coding same signal is transmitted from different antenna. In the case of diversity bit error rate is less when compared to multiplexing. Linear Dispersion Codes are used for diversity coding of 8X8 MIMO in order to obtain both capacity and diversity gains. Simulation parameters used are  $M=8$ ,  $N=8$ ,  $T=8$  and  $Q=32$  i.e.  $Q \leq NT$ . Rate granted by the proposed system is  $R=12$ . 8-QAM modulated symbols are divided into  $Q$  i.e. 32 substreams and dispersed in space and time using dispersion matrices. Fig 5.2 shows symbol error rate performance of LDC coded system for 8 QAM modulated symbol.

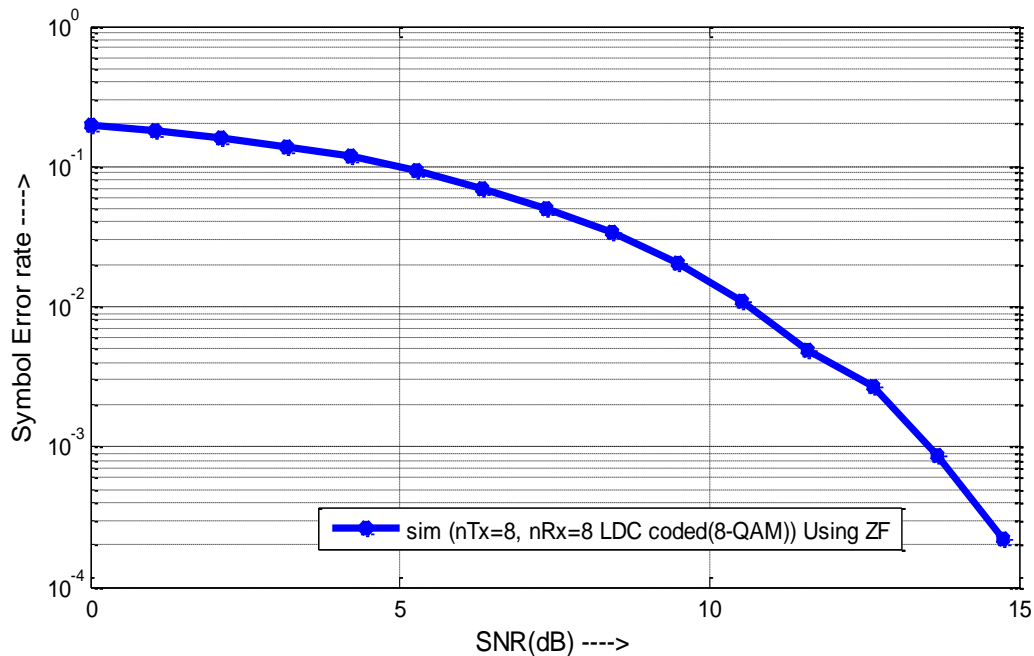
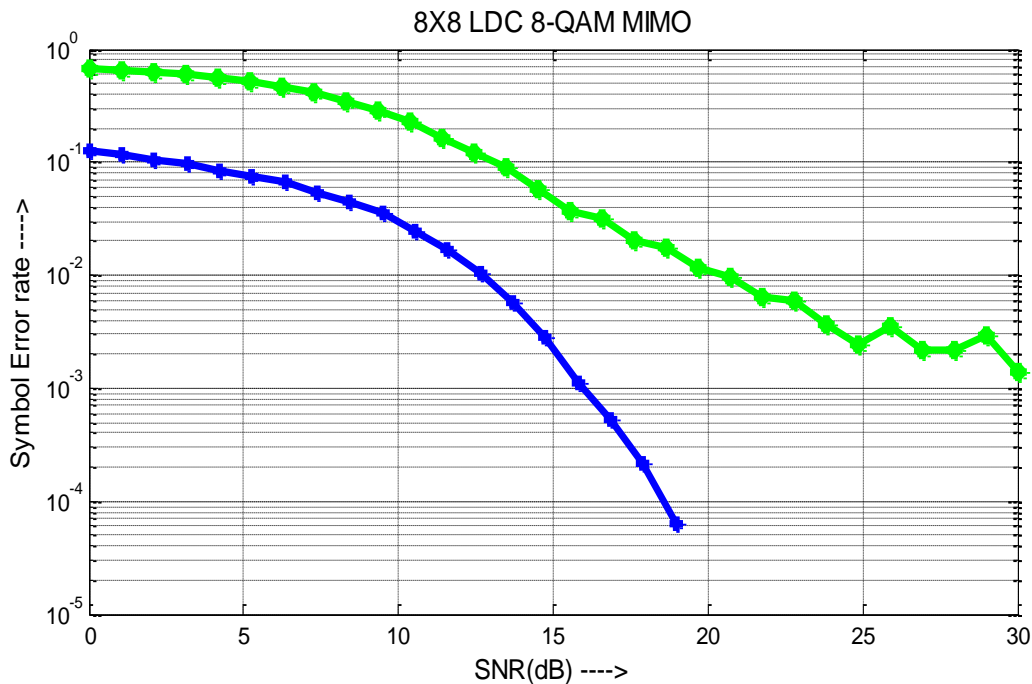

**Fig. 5.2 BER analysis of Linear Dispersion Coded 8x8 MIMO System**

Simulation results shows that less error rates are observed using diversity coding i.e. at SNR of 10 dB error rate of  $10^{-2}$  is observed. Decoding is done using Zero forcing decoding at the receiver side i.e. multiplying received signal with pseudo inverse at the receiver side.

Simulations are done to compare the performance of LD coded 8X8 MIMO with spatial multiplexed MIMO over a wide range of SNRs for 8 receive and 8 transmit antennas.

Fig. 5.3 shows improvement in the performance over wide range of SNR's using Linear Dispersion codes..



**Fig. 5.3 BER comparison of uncoded and LDC coded 8x8 Spatial Multiplexed MIMO System**

At SNR of 15dB symbol error rate by LDC coded MIMO is  $10^{-2.8}$  whereas by spatial multiplexed MIMO is  $10^{-1.9}$  hence the error rate is highly reduced

### 5.3 Precoded LDC Coded 8X8 MIMO

Channel information is used at the transmitter to obtain precoding matrix. In order to be able to obtain CSI at the transmitter, the channel should be fixed (non-mobile) or approximately constant over a reasonably large time period. In case of linear orthogonal dispersion codes it is assumed that channel remains constant for time interval T. In all of the simulations a Rayleigh fading channel is assumed with zero mean uncorrelated complex Gaussian noise across the receive antennas. In design of LDC codes for 8X8 MIMO it is considered that each row of the codeword S is transmitted over the same channel for time interval T. Hence the main difficulty in MIMO channels i.e. separation of the data streams which are sent in parallel is overcome by precoding matrix as it results in decoupling of data streams as discussed earlier. The performance

of the proposed scheme is evaluated in terms of the average bit symbol error rate (SER) versus signal-to-noise ratio per receive antenna.

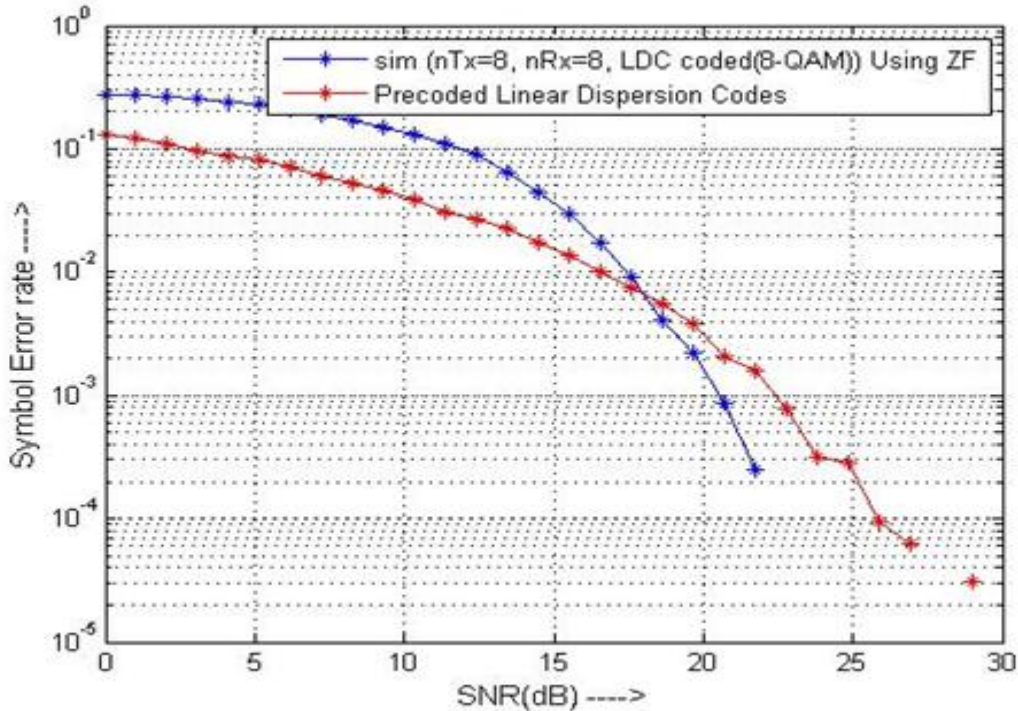

**Fig. 5.4 BER analysis of Precoded Linear Dispersive Codes for M=8,N=8 MIMO System**

8-QAM modulated symbols are first multiplied with the precoding matrix for beamforming. Fig.5.4 shows bit error rate performance of precoded linear dispersion codes using channel state information at the transmitter i.e. it is assumed that complete channel state information is available at transmitter side. The symbol error rate performance is improved at lower snr's i.e. up to SNR 18dB the symbol error performance is improved. The effect of channel known (in case of precoding) is only occurring at low SNRs. At higher SNR SER for both channel known or unknown approaches to equal.

### 5.4 Bit Interleaved LDC Coded 8X8 MIMO

In order to combat the effect of burst noise due to channel at higher SNRs channel coding is used in the existing system model. Simulations are carried out for 8X8 MIMO using convolution encoder with Linear Dispersion Codes in MATLAB. A rate 1/2 convolution encoder is using

$K=7$  i.e. constraint length 7 is used. Bit error rate of LODC coded 8X8 MIMO is calculated in Rayleigh channel with the use of convolution encoder in LDC coded 8x8 MIMO and bit interleaver at the transmitter and without the use of these two.

It has been shown that bit interleaving increases the Euclidean distance between the codewords of a convolutional code. In order to reduce the outage probability, row interleaving is proposed with help of convolution encoder and bit interleaver procedure that improves the high SNR performance of the code.

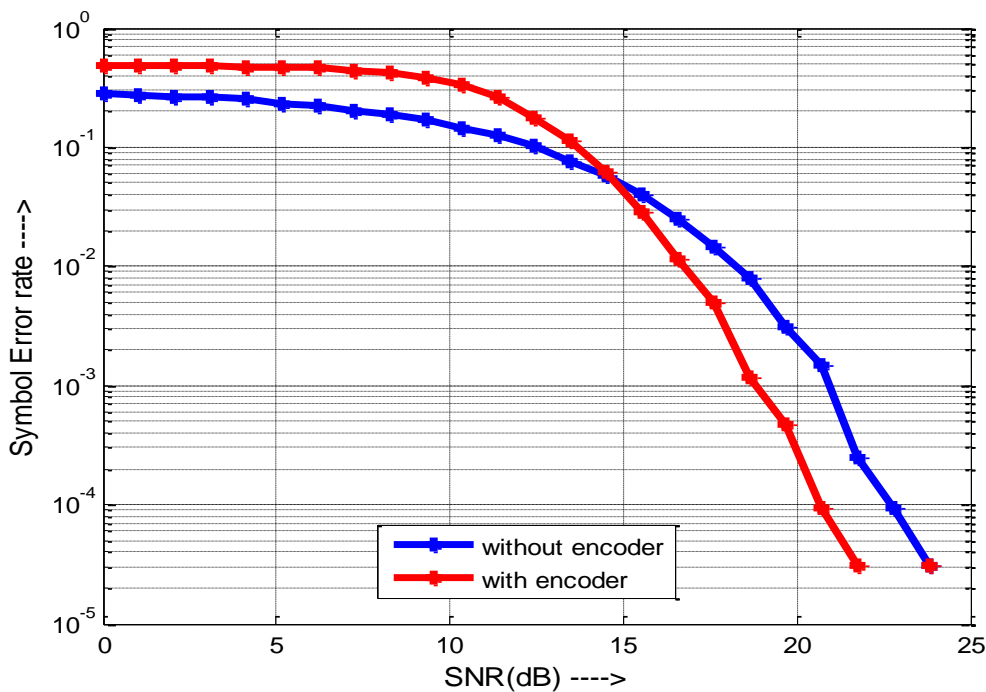

**Fig.5 .5 BER comparison of LDC coded 8X8 MIMO with and without use of convolution encoder at tx.**

Channel convolution encoding and bit interleaving is used along with Linear Dispersion Codes and performance is improved at higher SNR's i.e. above 15 dB. Fig 5.5 shows using convolution encoding symbol error performance of  $10^{-4.0}$  is obtained at SNR of 20dB whereas without channel coding at same symbol error performance is obtained at 24 dB, hence 4dB performance improvement is obtained.

## CHAPTER 5

### CONCLUSION AND FUTURE SCOPE

---

MIMO systems provide promising high data rates without the need of additional transmit power, hence MIMO systems are in intense research in recent years. In the case of MIMO if we increase the number of transmitter and receiver MIMO channel capacity increases and BER reduces. In the next generation 4G systems by using 8x8 MIMO system we can increase MIMO capacity and reduce the BER. For large number of antennas, using conventional space time coding techniques, the diversity gain can be obtained at the cost of reduced rates. Linear Dispersion Codes i.e. high rate codes are used to bridge the gap between increased capacity and reduced data rates.

CSI plays important factor during channel capacity. If transmitter has no idea of CSI then equal power is allocated to each transmitter. Capacity increases if transmitter knows the CSI. Hence precoding will reduce bit error rates since it provides the transmitter with a means of orienting its transmission along the geometry of the wireless channel, which greatly improves all aspects of system performance. CSI effects at only lower SNR, at higher SNR its effect is negligible. Precoding improves the symbol error rate performance of linear dispersion codes at lower SNR's i.e. up to SNR 18dB. In Precoded 8X8 LDC coded MIMO symbol error rate of  $10^{-1.5}$  is obtained at SNR of 7dB whereas without precoding at 13 dB, hence there is 6dB system performance improvement.

In case of Linear Dispersion coding it is assumed that channel remains constant for time interval T. In design of LDC codes for 8X8 MIMO it is considered that each row of the codeword S is transmitted over the same channel for time interval T. The performance of a communication system at higher SNRs is affected by outage probability which is the probability that a specific channel realization fails to support the required data rate. The LDC codes fails to the transmitted codeword if  $\|h\|$  drops below a certain level. In order to reduce the outage probability, row interleaving is proposed with help of convolution encoder and bit interleaver procedure that improves the performance of the code at higher SNRs. In order to combat the burst errors due to channel convolution encoding and bit interleaving is used along with Linear Dispersion Codes and performance is improved at higher SNRs i.e. above 15 dB. Using convolution encoding

symbol error performance of  $10^{-4.0}$  is obtained at SNR of 20dB whereas without channel coding at same symbol error performance is obtained at 24 dB, hence 4dB performance improvement is obtained.

Since Precoded LDC, i.e. the codes which used precoding matrix derived from channel state information helps in decoupling of the channels and hence improves the Bit error performance of 8X8 MIMO system. The convolution encoder and bit interleaver mitigates the effect of channel noise by increasing Euclidean distance between the code words.

## **Future Scope**

In the simulations, the decoding of the LD codes is done by Zero Forcing. The complexity of the decoding/detection process for space-time (ST) codes is a major constraint for the implementation of high speed Multiple-Input-Multiple-Output (MIMO) systems over wireless channels. A simplified Sphere Decoding (SD) algorithm to significantly reduce the decoding complexity for this family of LDC can be developed.

Since precoding improves the performance hence the insertion of precoding techniques into new wireless standards requires reliable means of quantizing the precoding vectors so that the volume of feedback needed for reliable transmission can be reduced.

In the precoding technique it is assumed that the channel correlation properties at the transmitter and receiver are decoupled using precoding vectors. But this is not always the case hence P-LDC structure could be extended to channels whose transmit and receive correlations are not decoupled.

## LIST OF PUBLICATIONS

---

- [1]. Satinder Kaur and Ankush Kansal, "Capacity Analysis of 8X8 MIMO System with traditional MIMO Systems," *International Conference on Electronics communication and Information Technology*, pp. 17, 4th-5th October, 2013.
- [2]. Satinder Kaur and Ankush Kansal, "BER Improvement of Linear Orthogonal Dispersion Coded 8X8 MIMO system using Convolution encoder and Bit interleaving," *International Journal OF Innovations in Engineering and Management (IJEM)*, ISSN No: 2319 – 3344, vol.3, no. 1, 2014.
- [3]. Satinder Kaur and Ankush Kansal," Capacity And Performance analysis of 8x8 MIMO system Using Precoded Linear Dispersive Codes", communicated in *Indian Journal Of Radio And Space Physics*, ISSN No: 0975-105X.

## References

- [1]. T. S. Rappaport, *Wireless Communications: Principles and Practice, 2nd ed. Prentice Hall, 2002.*
- [2]. A. Paulraj, R. Nabar, and D. Gore, *Introduction to Space-Time Wireless Communication, Cambridge University Press, New York, 2005.*
- [3]. E. Biglieri and G. Taricco, *Transmission and Reception with Multiple Antennas: Theoretical Foundations: theoretical Foundations and trends in communications and information theory, Hanover, MA, Now Publishers, 2004.*
- [4]. D. Gesbert, M. Shafi, D. Shan Shiu, P. J. Smith, and A. Naguib, "From theory to practice: an overview of MIMO space-time coded wireless systems," *IEEE Journal of Select Areas Communication*, vol. 21, no.3, pp. 281–302, 2003
- [5]. J. Guey, M. P. Fitz, M. R. Bell, and W. Kuo, "Signal design for transmitter diversity wireless communication systems over Rayleigh fading channels," in *Proceedings of IEEE Vehicular Technology Conference*, vol. 1, pp. 136–140, 1996.
- [6]. G. J. Foschini, "Layered space–time architecture for wireless communication in a fading environment when using multi-element antennas," *Bell Labs Technical Journal.*, vol. 1, no.11, pp. 41–59, 1996.
- [7]. Rahul Vze and Robert W. Heath, "On the Capacity And Diversity- Multiplexing Trade Off Of Two Way Relay Channel," *IEEE Tranaction on Information Theory* , vol. 57, no. 7, pp. 4219 - 4234, 2011.
- [8]. M. K. Simon, M.-S. Alouini, *Digital Communication over Fading Channel: A Unified Approach to Performance Analysis, John Wiley and Sohn, 2000.*
- [9]. I. E. Telatar, "Capacity of multi-antenna Gaussian channels," *European Transactions on Telecommunications*, vol. 10, no.11, pp. 585–595, 1999.
- [10]. Mir Muhammad Lodro, Muhammad Hanif Abro "Ergodic Capacity of MIMO Correlated Channels in Multipath Fading Environment with known Channel State Information" *International Journal of Electrical and Computer Engineering (IJECE)* ,vol.2, no.5, pp. 691-697, 2012.
- [11]. T. L. Marzetta and B. M. Hochwald, "Capacity of a mobile multiple antenna communication link in Rayleigh flat fading," *IEEE Transaction on Information Theory*, vol. 45,no.1, pp. 139–157, 1999.

- [12]. V. Tarokh, N. Seshadri, A. R. Calderbank, "Space-Time Codes for High Data Rate Wireless Communication: Performance Criterion and Code Construction", *IEEE Transaction on Information Theory*, vol. 44, no. 2, pp. 744-765, 1998.
- [13]. V. Tarokh, H. Jafarkhani, and A.R. Calderbank, "Space-time block coding for wireless communications: Performance results," *IEEE Journal on Select Areas in Communications*, vol. 17, pp. 451-460, 1999.
- [14]. S. M. Alamouti, "A simple transmit diversity technique for wireless communications," *IEEE Journal on Selected Areas in Communications*, vol. 16, no.10, pp. 1451-1458, 1998.
- [15]. V. Tarokh, H. Jafarkhani and A. R. Calderbank, "Space-time block codes from orthogonal designs," *IEEE Transaction on Information Theory*, vol. 45, no.7, pp. 1456-1467, 1999.
- [16]. A. V. Geramita and J. Seberry, Orthogonal Designs, Quadratic Forms and Hadamard Matrices, *Lecture Notes in Pure and Applied Mathematics*, vol. 43, 1979.
- [17]. H. Jafarkhani, "A quasi-Orthogonal space-time block code," *IEEE Transactions on Communications*, vol. 49, no.1, pp. 1-4, 2001.
- [18]. C. B. Papadidas and G. J. Foschini, "Capacity-approaching space-time codes for systems employing four transmitter antennas," *IEEE Transactions on Information Theory*, vol. 49, no.3, pp. 726-733, 2003.
- [19]. N. Sharma and C. B. Papadidas, "Improved quasi-orthogonal codes," *IEEE Wireless Communications and Networking Conference 2002, (Orlando, Florida, USA)*, pp. 169-171, 17-21, 2002.
- [20]. N. Sharma and C. B. Papadidas, "Improved quasi-orthogonal codes through constellation rotation," *Proceedings IEEE Conference on Acoustics, Speech, and Signal Processing*, vol. 4, no.5, pp. 3968-3971, 2002.
- [21]. B. Hassibi and B. Hochwald, "High-rate codes that are linear in space and time," in *Proceedings Allerton Conference on Communication, Control Computing*, 2000.
- [22]. Robert W. Heath, Arogyaswami J. Paulraj, "Linear dispersion codes for MIMO systems based on frame theory', *IEEE Transaction on Signal Processing*, vol.50, no.10, pp. 2429- 2441, 2002.

- [23]. Daiming Yang, Liming Zhang, Bo Hu, Yuanyuan Wang “Linear Orthogonal Dispersive Codes For MIMO System” *IEEE 6th CAS Symp. on Emerging Technologies: Mobile and Wireless Comm. Shanghai, China*, vol.2, no.2, pp. 583 – 586, 2004.
- [24]. L. Zheng and D. N. C. Tse, “Diversity and multiplexing: a fundamental tradeoff in multiple-antenna channels,” *IEEE Transaction on Information Theory*, vol. 49, no.5, pp. 1073-1096, 2003.
- [25]. H. Holma and A. Toskala, *LTE for UMTS – Evolution to LTE-Advanced*, 2nd ed., Wiley, 2011
- [26]. G. Ungerboeck, “Trellis-coded modulation with redundant signal sets, part I: Introduction,” *IEEE Communications Magazine*, vol. 25, no. 2, pp. 5–11, 1987.
- [27]. E. Visotsky and U. Madhow, “Space-time transmit precoding with imperfect feedback,” *IEEE Transactions on Information Theory*, vol. 47, no. 9, pp. 2632–2639, 2001.
- [28]. S. A. Jafar and A. Goldsmith, “Transmitter optimization and optimality of beamforming for multiple antenna systems,” *IEEE Transactions on Wireless Communications*, vol. 3, no. 7, pp. 1165–1175, 2004.
- [29]. M. Sandell, H. Vetter , and F. Tosato, “Joint Linear and Non linear Precoding in MIMO Systems” *IEEE Communications Letters*, vol. 15, no. 12, pp. 1265 - 1267, 2011.
- [30]. Brandenburg, LH; Wyner, AD (May–June 1974). "Capacity of the Gaussian Channel with Memory: The Multivariate Case" *Bell System Technical Journal*, vol. 53, no.5, pp. 1538-7305, 1974.
- [31]. G.J.Foschini and M.J.Gans, “On the Limits of Wireless Communication in a Fading Environment When Using Multiple Antennas,” *Wireless Personal Communication*, vol. 6, no.3, pp.226-235, 1998.
- [32]. G. J. Foschini, “Layered space-time architecture for wireless communication in a fading environment when using multi-element antennas”. *Bell Labs Technical Journal*, vol. 1, no. 2, pp. 41-59, 1996.

- [33]. V. Tarokh, N. Seshadri, and A. R. Calderbank, "Space-time codes for high data rate wireless communication: Performance criterion and code construction," *IEEE Transactions on Information Theory*, vol. 4, no.3, pp. 744–765, 1998.
- [34]. H. Jafarkhani, "A quasi-orthogonal space-time block code," *IEEE Communication Letters*, vol. 49, no. 1, pp. 1-4,2001.
- [35]. B. Hassibi and B. M. Hochwald, "High-rate codes that are linear in space and time," *IEEE Transaction Information Theory*, vol. 48, no.7,pp.1804-1824,2002.
- [36]. Hamid Ebrahimzad and Abbas Mohammadi, "Diversity-Multiplexing Tradeoff in MIMO System with Finite SNR" *European Conference on Wireless Technology*, no.10, pp.146 - 149, 2007.
- [37]. Yonghua Li Zhang, Dong Liang and Tiejun Lv, "Relation between Beamforming and Diversity in MIMO System: A Capacity Perspective"<sup>5<sup>th</sup></sup> *Intenational Conference on Wireless Communication Networking and Mobile Computing* , Bijing, China, pp. 1-4, 2009.
- [38]. E. Akay, E. Sengul, and E. Ayanoglu, "Bit interleaved coded multiple beamforming," *IEEE Transaction on Communications*, vol. 55, no. 9, pp.1802–1811, 2007.
- [39]. Constantin Siriteanu, Xiaonan Shi and Yoshikazu Miyanaga, "Analysis and Simulation of MIMO Zero-Forcing Detection Performance for Correlated and Estimated Rician-Fading Channel "Communication Theory workshop", Australia, pp.182 – 187, 2010.
- [40]. Frederik Simoens, Henk Wymeersch, Marc Moeneclaey, "Linear Precoders for Bit-Interleaved Coded Modulation on AWGN Channels: Analysis and Design Criteria" *IEEE transactions on information theory*, vol.54, no. 1, pp. 87-89, January 2008.
- [41]. K. Werner, H. Asplund, D.V.P. Figueiredo, N. Jaldén and B. Halvarsson, "LTE-Advanced 8×8 MIMO Measurements in an Indoor Scenario" *Proceedings of International Symposium on Antennas and Propagation, Nagoya, Japan*, 2012.
- [42]. Leslie C. Wood and William S. Hodgkiss, "Performance of MIMO Channel Models with Channel State Information at the Transmitter" *IEEE Globecomunications*, vol.12, no.11, pp.1-5, 2008.

- [43]. C. Windpassinger, R. F. H. Fischer, T. Vencel, and J.B. Huber, "Precoding in multiantenna and multi-user communications" *IEEE Transactions on wireless communications*, vol.3, no.4, pp.1305 – 1316, 2004.
- [44]. S. Zhou and G. Giannakis, "Optimal transmitter eigen-beamforming and space-time block coding based on channel mean feedback," *IEEE Transactions on Signal Processing* ,vol. 50, no. 10, pp. 2599–2613, 2002.
- [45]. A. J. Viterbi and J. K. Omura, *Principles of Digital Communication and Coding*, New York: McGraw-Hill, 1979.