

A Comparative Study of Different Advance Control Techniques for Steam Drum Level Control of Boiler

*A Thesis submitted in partial fulfillment of the
requirements for the award of degree of*

**Master of Engineering
in
Electronic Instrumentation and Control**



Submitted By

Abhinav Gautam
Roll No: 800951001

Under the Guidance of

Ms. Gagandeep Kaur
Assistant Professor

Dr. Yaduvir Singh
Associate Professor

**Department of Electrical and Instrumentation Engineering
Thapar University**

(Established under the section 3 of UGC act, 1956)

Patiala, 147004, Punjab, India
July 2011

DECLARATION

I hereby certify that the work which is being presented in the thesis entitled “**A Comparative Study of Different Advance Control Techniques for Steam Drum Level Control of Boiler**” in partial fulfillment of award of degree of **Master of Engineering in Electronics Instrumentation and Control** submitted in Electrical and Instrumentation Engineering department, Thapar University, Patiala is an authentic record of my own work carried under the supervision of **Ms. Gagandeep Kaur**, Assistant Professor, Department of Electrical and Instrumentation Engineering, Thapar University, Patiala, Punjab and **Dr. Yaduvir Singh**, Associate Professor, Department of Electrical and Instrumentation Engineering, Thapar University, Patiala, Punjab.

Date: 28-06-11

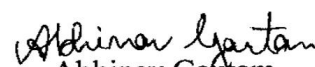
Abhinav Gautam
800951001

I certify that the above statement made by the student is correct to the best of my knowledge and belief.

Date: 28-06-11

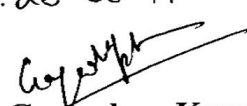
Ms. Gagandeep Kaur
Assistant Professor
Department of Electrical and
Instrumentation Engineering
Thapar University, Patiala
Punjab

Dr. Yaduvir Singh
Associate Professor
Department of Electrical and
Instrumentation Engineering
Thapar University, Patiala
Punjab

Countersigned By

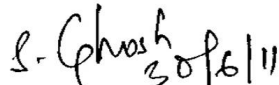
Dr. Smarajit Ghosh
Head of Department
Department of Electrical and Instrumentation
Engineering
Thapar University, Patiala
Punjab

Dr. S K Mohapatra
Dean of Academic Affairs
Thapar University, Patiala
Punjab

ABSTRACT

The largest boilers could justify sophisticated boiler controls earlier, but now high fuel costs and occasional limited fuel availability make it necessary to improve boiler efficiency and minimize costly steam losses and disturbances. Drum level controls have become more important, as the boiler loads are being varied to meet needs, rather than operating at full capacity and wasting fuel and steam. The effects of feed pressure surges and steam flow on drum level dictate more complex controls.

This work provides the control of steam drum level using advance control techniques like fractional order PID controller technique and fuzzy logic PID controller technique, to get better response from the system. The control system contains two loops, a feedforward control loop using the steam flow as disturbance signal and cascade control loop using drum water level as measuring signal in primary loop and feedwater pressure as measuring signal in secondary loop. The feedforward controller output signal is summed along with the output of the primary controller to establish the set point for the secondary controller. This scheme is effective because steam flow changes are immediately fed forward to change the final feedwater set point for the control actuator. In this way, feedwater flow tracks steam flow and any disturbances in the feedwater system will be arrested quickly. A comparative study is made on the performance of the fractional order PID controller and fuzzy logic PID controller for getting better control efficiency.

From the simulation results and graphs, fuzzy PID controller gives better response than conventional PID controller as there is improvement in control parameters with settling time improved by 0.63 seconds, peak overshoot by 0.57 %, ISE by 0.12 % decrease and ITAE by 9.05 % decrease. Further the response of fractional PID controller is better than both conventional and fuzzy PID controller. The control parameters of fractional PID controller is improved as compared to fuzzy PID controller with settling time improved by 6.36 seconds, peak overshoot by 3.09 %, ISE by 0.14 % decrease and ITAE by 4.99 % decrease. There is a remarkable improvement in the control parameters of fractional PID controller as compared to conventional PID controller with settling time improved by 6.99 seconds, peak overshoot by 3.67 %, ISE by 0.26 % decrease and ITAE by 13.59 % decrease.

ACKNOWLEDGEMENT

I would like to express my gratitude to **Ms. Gagandeep Kaur**, Assistant Professor, Electrical and Instrumentation Engineering Department, Thapar University, Patiala and **Dr. Yaduvir Singh**, Associate Professor, Electrical and Instrumentation Engineering Department, Thapar University, Patiala for their patient guidance and support throughout this thesis work. I am truly very fortunate to have the opportunity to work with them. They have also provided me help in technical writing and presentation style, and I found this guidance to be extremely valuable. I am very thankful to head of the Department, **Dr. Smarajit Ghosh**, for his encouragement, support and providing the facilities for the completion of this thesis. I am also thankful to entire faculty and staff members of Electrical and Instrumentation Engineering Department for their unyielding encouragement. I am greatly indebted to all my friends, who have graciously applied themselves to the task of helping me with ample morale support and valuable suggestions. Finally, I would like to extend my gratitude to all those persons who directly or indirectly helped me in the process and contributed towards this work.

Abhinav Gautam

CONTENTS

CONTENTS	PAGE NO.
FRONT PAGE	I
DECLARATION	II
ABSTRACT	III
ACKNOWLEDGEMENT	IV
CONTENTS	V-VIII
LIST OF FIGURES	IX-XI
LIST OF TABLES	XII
LIST OF SYMBOLS AND ABBREVIATIONS	XIII
Chapter 1: Introduction	1-2
1.1 Overview	1
1.2 Objective of Thesis	2
1.3 Organization of Thesis	2
Chapter 2: Industrial Boilers and Control	3-28
2.1 Industrial Boiler	3
2.2 Types of Boiler	5
2.2.1 Pot Boiler	6
2.2.2 Fire-Tube Boiler	6
2.2.3 Water Tube Boiler	7
2.2.4 Flash Boiler	7
2.2.5 Sectional Boiler	8
2.2.6 Multi Tube Boiler	8
2.2.7 Superheated Steam Boiler	9
2.2.8 Hydronic Boiler	10
2.3 Material of Boiler	11
2.4 Fuel for Boiler	11
2.5 Safety in Boiler	12

2.6 Applications	12
2.7 Boiler Steam Drum Level Control Systems	13
2.8 Control Structure of Proposed System	15
2.9 Types of Controller	15
2.9.1 Feedback Controller	16
2.9.1.1 Advantages of Feedback Control	16
2.9.1.2 Disadvantages of Feedback Control	16
2.9.1.3 Applications of Feedback Control	17
2.9.2 Feedforward Controller	17
2.9.2.1 Advantages of Feedforward Control	17
2.9.2.2 Disadvantages of Feedforward Control	17
2.9.3 Cascade Controller	18
2.9.3.1 Advantages of Cascade Control	19
2.9.3.2 Disadvantages of Cascade Control	19
2.10 PID Controller	19
2.11 Fractional Order Calculus	21
2.12 Fractional Order Controller	22
2.13 Transient Response of PID Controller	22
2.14 Tuning the PID Controller	25
2.15 Ziegler-Nichols Tuning	26
2.15.1 First Method	26
2.15.2 Second Method	27
Chapter 3: Literature Review	29-31
Chapter 4: Fuzzy Logic: An Overview	32-43
4.1 Fuzzy Logic: Introduction	32
4.2 Fuzzy Logic: A Choice to All Control Problems	33
4.3 Fuzzy Logic: Can Implement in All Control Problems	34
4.4 Fuzzy Logic: Operations	35
4.5 Fuzzy Logic: Types	35
4.5.1 Type I Fuzzy Set	35
4.5.2 Type II Fuzzy Set	36

4.6 Fuzzy Inference System	36
4.6.1 Mamdani Based FIS	37
4.6.2 Sugeno Based FIS	37
4.7 Defuzzification	39
4.8 Fuzzy Control: Scheme	40
4.9 Fuzzy Logic: Applications	42
Chapter 5: Problem Formulation	44-51
5.1 Process Description	44
5.2 Problem Definition	45
5.3 Shrink/Swell Effect	46
5.4 Fuzzy Logic Controller: Design	47
Chapter 6: Results and Discussions	52-76
6.1 1-Element Steam Drum Level Control without Load Disturbance	52
6.2 1-Element Steam Drum Level Control with Load Disturbance	54
6.3 2-Element Steam Drum Level Control without Feedwater Flow Disturbance	56
6.4 2-Element Steam Drum Level Control with Feedwater Flow Disturbance	58
6.5 3-Element Steam Drum Level Control using Conventional PID Controller	59
6.6 3-Element Steam Drum Level Control using Fuzzy PID Controller	62
6.7 3-Element Steam Drum Level Control using Fractional PID Controller	66
6.7.1 With $\lambda=1$ and varying values of $\mu<1$	67
6.7.2 With varying values of $\lambda<1$ and $\mu=1$	68
6.7.3 With varying values of $\lambda<1$ and $\mu<1$	69
6.7.4 With $\lambda=1$ and varying values of $\mu>1$	70
6.7.5 With varying values of $\lambda>1$ and $\mu=1$	71
6.7.6 With varying values of $\lambda>1$ and $\mu>1$	72

6.7.7 With varying values of $\lambda > 1$ and $\mu < 1$	73
6.7.8 With varying values of $\lambda < 1$ and $\mu > 1$	74
6.8 Comparison of Different Control Techniques	75
Chapter 7: Conclusion and Future Scope	77
REFERENCES	78-82

LIST OF FIGURES

FIGURE	FIGURE NAME	PAGE NO.
Fig 2.1	Industrial Boiler	4
Fig 2.2	Steam Cycle of Boiler	5
Fig 2.3	Fire-Tube Boiler	7
Fig 2.4	Water Tube Boiler	8
Fig 2.5	Single Element Drum Level Control	13
Fig 2.6	Two Element Drum Level Control	14
Fig 2.7	Three Element Drum Level Control	15
Fig 2.8	Feedback Control Loop	16
Fig 2.9	Schematic Diagram of Feedforward Control	17
Fig 2.10	Example of Feedforward Control	18
Fig 2.11	Schematic Diagram of Cascade Control	19
Fig 2.12	PID Controller Architecture in Time Domain and Laplace Domain	21
Fig 2.13	Plot of PV v/s Time of Second Order System, for Three Values of K_p	23
Fig 2.14	Plot of PV v/s Time of Second Order System, for Three Values of K_i	23
Fig 2.15	Plot of PV v/s Time of Second Order System, for Three Values of K_d	24
Fig 2.16	Response Curve for Ziegler-Nichols First Method	27
Fig 4.1	Fuzzy Logic Membership Function	36
Fig 4.2	Block diagram of Fuzzy Logic System	37
Fig 4.3	Fuzzy Rule Base in the case of a Mamdani Fuzzy Inference System	38
Fig 4.4	Surface View in the case of a Mamdani Fuzzy Inference System	39
Fig 4.5	Classical Feedback Control Scheme	40
Fig 4.6	Fuzzy Logic Control Scheme	41

Fig 5.1	Boiler Drum	45
Fig 5.2	Architecture of Fuzzy Control	47
Fig 5.3	Mamdani Fuzzy Inference System Developed for Fuzzy Controller	49
Fig 5.4	Membership function for Input 1	49
Fig 5.5	Membership function for Input 2	49
Fig 5.6	Membership function for Output	50
Fig 5.7	Rule Base	50
Fig 5.8	Rule Viewer for Fuzzy Inference System	51
Fig 6.1	1-Element Steam Drum Level Control using PID Controller without Load Disturbance	52
Fig 6.2	Unit Step Response of 1- Element Steam Drum Level Control using PID Controller without Load Disturbance	53
Fig 6.3	1-Element Steam Drum Level Control using PID Controller with Load Disturbance	54
Fig 6.4	Unit Step Response of 1- Element Steam Drum Level Control using PID Controller with Load Disturbance	55
Fig 6.5	2-Element Steam Drum Level Control using PID Controller without Feedwater Flow Disturbance	56
Fig 6.6	Unit Step Response of 2- Element Steam Drum Level Control using PID Controller without Feedwater Flow Disturbance	57
Fig 6.7	2-Element Steam Drum Level Control using PID Controller with Feedwater Flow Disturbance	58
Fig 6.8	Unit Step Response of 2- Element Steam Drum Level Control using PID Controller with Feedwater Flow Disturbance	59
Fig 6.9	3-Element Steam Drum Level Control with Conventional PID as Primary Controller	61
Fig 6.10	Unit Step Response of 3-Element Boiler Drum Level Control using Conventional PID	61

Fig 6.11	Mamdani Fuzzy Inference System Developed for Fuzzy Controller	62
Fig 6.12	Membership Function for Input 1	63
Fig 6.13	Rule Base	63
Fig 6.14	Rule Viewer for Fuzzy Inference System	64
Fig 6.15	3-Element Steam Drum Boiler with Fuzzy PID as Primary Controller	64
Fig 6.16	Fuzzy PID Controller	65
Fig 6.17	Unit Step Response of 3-Element Steam Drum Level Control using Fuzzy PID as Primary Controller	65
Fig 6.18	3-Element Steam Drum Boiler with Fractional PID Controller as Primary Controller	66
Fig 6.19	Unit Step Response of 3-Element Boiler Drum Level Control using FPID for Different Values of $\mu < 1$	67
Fig 6.20	Unit Step Response of 3-Element Boiler Drum Level Control using FPID for Different Values of $\lambda < 1$	68
Fig 6.21	Unit Step Response of 3-Element Boiler Drum Level Control using FPID for Different Values of $\lambda < 1$ and $\mu < 1$	69
Fig 6.22	Unit Step Response of 3-Element Boiler Drum Level Control using FPID for Different Values of $\mu > 1$	70
Fig 6.23	Unit Step Response of 3-Element Boiler Drum Level Control using FPID for Different Values of $\lambda > 1$	71
Fig 6.24	Unit Step Response of 3-Element Boiler Drum Level Control using FPID for Different Values of $\lambda > 1$ and $\mu > 1$	72
Fig 6.25	Unit Step Response of 3-Element Boiler Drum Level Control using FPID for Different Values of $\lambda > 1$ and $\mu < 1$	73
Fig 6.26	Unit Step Response of 3-Element Boiler Drum Level Control using FPID for Different Values of $\lambda < 1$ and $\mu > 1$	74
Fig 6.27	Unit Step Response of 3-Element Boiler Drum Level Control using Different Control Techniques	75

LIST OF TABLES

TABLE	TABLE NAME	PAGE NO.
Table 2.1	Key Characteristics of Commercial PID Controller	24
Table 2.2	Ziegler-Nichols Recipe: First Method	27
Table 2.3	Ziegler Nichols Recipe: Second Method	28
Table 5.1	Linguistic Variable of Fuzzy Logic Control	48
Table 5.2	IF-THEN Rule Base for Fuzzy Logic Control	48
Table 6.1	Different Parameters	53
Table 6.2	Different Parameters	55
Table 6.3	Different Parameters	57
Table 6.4	Different Parameters	59
Table 6.5	Different Parameters	62
Table 6.6	Different Parameters	66
Table 6.7	Comparison of Parameters for Different Combinations of λ and μ	67
Table 6.8	Comparison of Parameters for Different Combinations of λ and μ	68
Table 6.9	Comparison of Parameters for Different Combinations of λ and μ	69
Table 6.10	Comparison of Parameters for Different Combinations of λ and μ	70
Table 6.11	Comparison of Parameters for Different Combinations of λ and μ	71
Table 6.12	Comparison of Parameters for Different Combinations of λ and μ	72
Table 6.13	Comparison of Parameters for Different Combinations of λ and μ	73
Table 6.14	Comparison of Parameters for Different Combinations of λ and μ	74
Table 6.15	Comparison of Parameters for Different Control Techniques	76

LIST OF SYMBOLS AND ABBREVIATIONS

PID	Proportional Integral Derivative
HTHW	High Temperature Hot Water
BTUH	British Thermal Units per Hour
ASME	American Society of Mechanical Engineers
PSI	Pound Square Inch
PI	Proportional Integral
PV	Process Variable
K_c	Controller Gain
K_p	Proportional Gain
K_i	Integral Gain
K_d	Derivative Gain
T_i	Integral Time
T_d	Derivative Time
PB	Proportional Band
K_{cr}	Ultimate Gain
P_{cr}	Ultimate Period Of Sustaining Oscillations
FPID	Fractional Proportional Integral Derivative
FOPID	Fractional Order Proportional Integral Derivative
GA	Genetic Algorithm
FIS	Fuzzy Inference System
MIMO	Multiple Input and Multiple Output
MISO	Multiple Input and Single Output
TSK	Takagi-Sugeno-Kang
T_s	Settling Time
M_p	Peak Overshoot
ISE	Integral Square Error
ITAE	Integral Time Absolute Error

Chapter -1

Introduction

1.1 Overview

Boiler is a closed vessel in which water or other fluid is heated. Different types of boilers are there and can generate hot water or steam by absorbing heat from another fluid. The heated or vaporized fluid exits the boiler for use in various processes in different heating applications. A boiler or steam generator is employed wherever a source of steam is required.

The Steam drum is an integral part of a boiler. This vessel's primary function is to provide a surface area and volume near the top of the boiler where separation of steam from water can occur. Low level affects the recirculation of water to the boiler tubes and reduces the water to the boiler tubes, which overheats and can cause damage to the boiler tubes. High level reduces the surface area, and can lead to water and dissolved solids entering the steam distribution system. Therefore, steam drum water level control is critical to safe operation of the boiler and the steam turbine. The objective of the drum level control system is to maintain the water-steam interface at the specified level and provide a continuous mass balance by replacing every pound of steam and water removed with a pound of feedwater. The interface level is subject to many disturbances, steam pressure being a major one. As steam pressure changes due to demand, there is transient change in level due to the effect of pressure on entrained steam bubbles below the steam interface level. As pressure drops, a rise in level, called swell, occurs because the trapped bubbles enlarge. As pressure rises, a drop in level occurs. This is called shrink.

There are three basic types of drum level control systems:

- Single-element drum level control system
- Two-element drum level control system
- Three-element drum level control system

Their application depends upon the specific boiler size and load changes.

1.2 Objective of Thesis

The primary objective of the thesis is to make a comparative study of different advance control strategies to control the steam drum level. The first step is to implement one element steam drum level control, two element steam drum level control and three element steam drum level control. Then to implement different controllers to control the three element steam drum level. PID controller, feedforward controller, cascade controller, fuzzy based PID controller and fractional order PID controller are designed to control the steam drum level of the boiler. A comparative study of the transient parameters and performance indices are performed to determine the better control architecture.

1.3 Organization of Thesis

Chapter 1 gives an introduction of the thesis.

Chapter 2 gives an overview of industrial boiler and its control strategies like single element drum level, two element drum level and three element drum level control.

Chapter 3 gives a relevant literature review regarding control of boiler.

Chapter 4 gives an introduction about fuzzy logic and its control application.

Chapter 5 is the problem formulation.

Chapter 6 shows the results and discussion.

Chapter 7 provides conclusion of entire thesis work and proposes the future scope.

Chapter 2

Industrial Boilers and Control

This chapter discusses different kind of boilers and its control strategies.

2.1 Industrial Boiler

Boiler is a closed vessel in which water or other fluid is heated. It does not have to have a burner. All of these types can generate hot water or steam by absorbing heat from another fluid. That other fluid can be steam and create steam or hot water, it can be HTHW and generate steam, or it can be a hot liquid or gas from some chemical process that is hot enough to do the job. One of the largest low pressure steam boilers that was ever built in the late 1960's and it generated steam by oxidizing a liquid. The heat source was a large volume of oil which air was forced through to oxidize the liquid similar to combustion but at a low temperature and nowhere near complete combustion. Twenty four feet in diameter and ninety feet tall with thousands of square feet of heating surface it made about 25,000 pounds per hour.

Other projects included a hot water boiler using 500°F air from a steelmaking operation rated at 100 million btuh. Operating that type of equipment to get the most steam out of it is wise because you save on fuel that would have to be used to generate that steam. These boilers can be constructed as unfired pressure vessels in accordance with Section VIII of the ASME Code, "Rules for Construction of Pressure Vessels." Boilers that are fired must be built to Section I or Section IV but their construction is limited to materials that can handle the high rates of heat transfer required for direct fired equipment. Boilers using waste heat can require materials of construction that cannot handle direct firing but are essential to prevent corrosion in the waste heat application. In simpler words, a fired boiler cannot be built in stainless steel, an unfired boiler can be. Since there is a fixed relationship between pressure and temperature for steam and water, pressure has to increase. To heat product or other materials to high temperatures, pressures may get very high. Equipment that heats water in an open container or very small one is not a boiler. The hot water heater in our home is not considered a boiler

unless it holds more than 120 gallons. Another limit on the size of a boiler is an internal diameter of 6 inches or less. The exceptions found in the code are occasionally stretched to create boilers that, by definition, are not. Fired air heaters are not boilers unless the air is under pressure. Any application that heats air or any other gas for that matter, that does not contain the heated fluid in an enclosed vessel, is normally called a furnace. If the fluid is air or another gas and it is under pressure then it does meet the definition of a boiler. There are many boilers unique to their respective industry. Asphalt heaters, flux heaters, many forms of waste heat boilers and equipment like recovery boilers which convert product can be encountered by burning it. The principles discussed here will allow understanding those unique boilers which, by virtue of their uniqueness, are best understood by reading the operating and maintenance instruction manuals for them. This section contains general descriptions of the basic elements of a boiler plant to provide a basic understanding of the systems and equipment.

The heated or vaporized fluid exits the boiler for use in various processes or heating applications. It is a device used to create steam by applying heat energy to water. Although the definitions are somewhat flexible, it can be said that older steam generators were commonly termed boilers and worked at low to medium pressure of 1-300 psi, but at pressures above that figure it is more usual to speak of a steam generator.



Figure 2.1: Industrial Boiler

A boiler or steam generator is employed wherever a source of steam is required. The form and size depends on the application: mobile steam engines such as steam locomotives, portable engines and steam-powered road vehicles typically use a smaller

boiler that forms an integral part of the vehicle, stationary steam engines, industrial installations and power stations will usually have a larger separate steam generating facility connected to the point-of-use by piping. A notable exception is the steam-powered fireless locomotive, where separately-generated steam is transferred to a receiver on the locomotive.

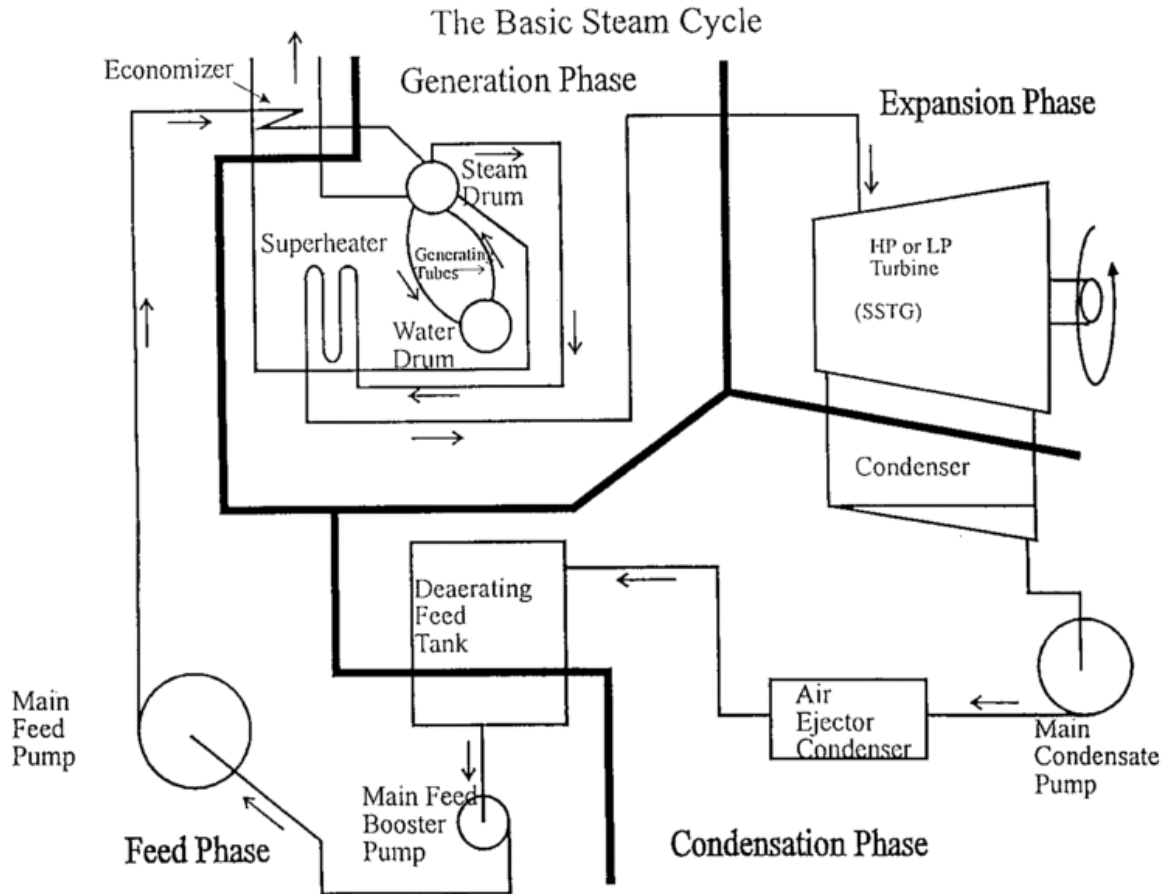

Figure 2.2: Steam Cycle of Boiler

The above figure 2.2 shows the steam cycle of a boiler. It shows the passage of steam in a boiler.

2.2 Types of Boiler

There are various types of boilers used in the industries, some of these are given below:

- Pot Boiler
- Fire-Tube Boiler
- Water Tube Boiler
- Flash Boiler
- Sectional Boiler
- Multi Tube Boiler
- Superheated Steam Boiler
- Hydronic Boiler

2.2.1 Pot Boiler

Pot boiler is also called as Haycock boiler: a primitive kettle where a fire heats a partially filled water container from below. 18th Century Haycock boilers generally produced and stored large volumes of very low pressure steam, often hardly above that of the atmosphere. These could burn wood or most often, coal. Efficiency was very low.

2.2.2 Fire-Tube Boiler

Here, water partially fills a boiler barrel with a small volume left above to accommodate the steam known as steam space. This is the type of boiler used in nearly all steam locomotives. The heat source is inside a furnace or firebox that has to be kept permanently surrounded by the water in order to maintain the temperature of the heating surface just below boiling point. The furnace can be situated at one end of a fire-tube which lengthens the path of the hot gases, thus augmenting the heating surface which can be further increased by making the gases reverse direction through a second parallel tube or a bundle of multiple tubes known as two-pass or return flue boiler, alternatively the gases may be taken along the sides and then beneath the boiler through flues known as 3-pass boiler. In the case of a locomotive type boiler, a boiler barrel extends from the firebox and the hot gases pass through a bundle of fire tubes inside the barrel which greatly increase the heating surface compared to a single tube and further improve heat transfer. Fire-tube boilers usually have a comparatively low rate of steam production, but high steam storage capacity. Fire-tube boilers mostly burn solid fuels.

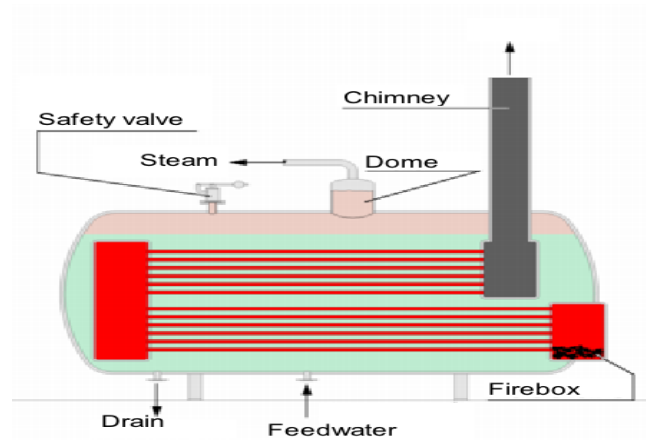

Figure 2.3: Fire-Tube Boiler

2.2.3 Water Tube Boiler

In this type, the water tubes are arranged inside a furnace in a number of possible configurations: often the water tubes connect large drums, the lower ones containing water and the upper ones, steam and water; in other cases, such as a monotube boiler, water is circulated by a pump through a succession of coils. This type generally gives high steam production rates, but less storage capacity than the above. Water tube boilers can be designed to exploit any heat source and are generally preferred in high pressure applications since the high pressure water/steam is contained within small diameter pipes which can withstand the pressure with a thinner wall.

2.2.4 Flash Boiler

It is a type of water-tube boiler, whose tubes are strong and close together with water pumped through the tubes. The tubes are kept very hot so the water feed is quickly flashed into steam and superheated. They have these advantages:

- Less weight and bulk.
- Less time to raise steam from cold.

A flash boiler is much easier than an ordinary boiler to overheat, as there is no large reservoir of water to keep the tubes from high temperature if the water flow is interrupted or inadequate.

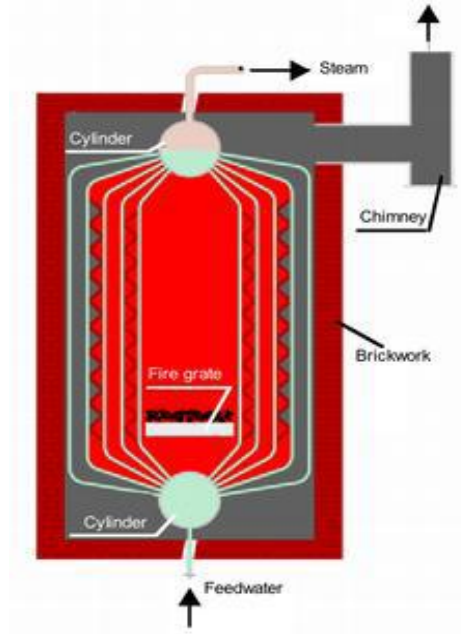

Figure 2.4: Water Tube Boiler

2.2.5 Sectional Boiler

In a cast iron sectional boiler, sometimes called a pork chop boiler, the water is contained inside cast iron sections. These sections are assembled on site to create the finished boiler.

2.2.6 Multi Tube Boiler

A significant step forward came in France in 1828 when Marc Seguin devised a two-pass boiler of which the second pass was formed by a bundle of multiple tubes. A similar design with natural induction used for marine purposes was the popular Scotch marine boiler.

Prior to the Rainhill trials of 1829 Henry Booth, treasurer of the Liverpool and Manchester Railway suggested to George Stephenson, a scheme for a multi-tube one-pass horizontal boiler made up of two units: a firebox surrounded by water spaces and a boiler barrel consisting of two telescopic rings inside which were mounted 25 copper tubes; the tube bundle occupied much of the water space in the barrel and vastly improved heat transfer. Old George immediately communicated the scheme to his son Robert and this was the boiler used on Stephenson's Rocket, outright winner of the trial. The design was

and formed the basis for all subsequent Stephensonian-built locomotives, being immediately taken up by other constructors; this pattern of fire-tube boiler has been built ever since.

2.2.7 Superheated Steam Boiler

Most boilers heat water until it boils, and then the steam is used at saturation temperature, that is, saturated steam. Superheated steam boilers boil the water and then further heat the steam in a super heater. This provides steam at much higher temperature, but can decrease the overall thermal efficiency of the steam generating plant due to the fact that the higher steam temperature requires a higher flue gas exhaust temperature. There are several ways to circumvent this problem, typically by providing a feedwater heating economizer, and/or a combustion air heater in the hot flue gas exhaust path. There are advantages to superheated steam and this may and usually will increase overall efficiency of both steam generation and its utilization considered together: gains in input temperature to a turbine should outweigh any cost in additional boiler complication and expense. There may also be practical limitations in using wet steam, as causing condensation droplets will damage turbine blades. Superheated steam presents unique safety concerns because, if there is a leak in the steam piping, steam at such high pressure/temperature can cause serious, instantaneous harm to anyone entering its flow. Since the escaping steam will initially be completely superheated vapour, it is not easy to see the leak, although the intense heat and sound from such a leak clearly indicates its presence. The super heater works like coils on an air conditioning unit, however to a different end. The steam piping with steam flowing through it is directed through the flue gas path in the boiler furnace. This area typically is between 1,300°C (2,372°F)-1,600°C (2,912°F). Some super heaters are radiant type absorb heat by radiation, others are convection type absorb heat via a fluid, that is, gas and some are a combination of the two. So whether by convection or radiation the extreme heat in the boiler furnace/flue gas path will also heat the super heater steam piping and the steam within as well. It is important to note that while the temperature of the steam in the superheater is raised, the pressure of the steam is not increased as the turbine or moving pistons offer a continuously expanding space and the pressure remains the same as that of the boiler.

The process of superheating steam is most importantly designed to remove all droplets entrained in the steam to prevent damage to the turbine blading and/or associated piping.

2.2.8 Hydronic Boiler

Hydronic boilers are used in generating heat for residential and industrial purposes. They are the typical power plant for central heating systems fitted to houses in northern Europe where they are commonly combined with domestic water heating, as opposed to the forced-air furnaces or wood burning stoves more common in North America. The hydronic boiler operates by way of heating water/fluid to a preset temperature or sometimes in the case of single pipe systems, until it boils and turns to steam and circulating that fluid throughout the home typically by way of radiators, baseboard heaters or through the floors. The fluid can be heated by any means like gas, wood, fuel oil, etc, but in built-up areas where piped gas is available, natural gas is currently the most economical and therefore the usual choice. The fluid is in an enclosed system and circulated throughout by means of a motorized pump. The name can be a misnomer in that, except for systems using steam radiators, the water in a properly functioning hydronic boiler never actually boils. Most new systems are fitted with condensing boilers for greater efficiency. These boilers are referred to as condensing boilers because they condense the water vapour in the flue gases to capture the latent heat of vaporization of the water produced during combustion. Hydronic systems are being used more and more in new construction in North America for several reasons. Among the reasons are:

- They are more efficient and more economical than forced-air systems. Although initial installation can be more expensive, because of the cost of the copper and aluminium.
- The baseboard copper pipes and aluminium fins take up less room and use less metal than the bulky steel ductwork required for forced-air systems.
- They provide more even, less fluctuating temperatures than forced-air systems. The copper baseboard pipes hold and release heat over a longer period of time than air does, so the furnace does not have to switch off and on as much. Copper heats mostly through conduction and radiation, whereas forced-air heats mostly

through forced convection. Air has much lower thermal conductivity and higher specific heat than copper; however, convection results in faster heat loss of air compared to copper.

- They do not dry out the interior air as much.
- They do not introduce any dust, allergens, mold, or in the case of a faulty heat exchanger, combustion by-products into the living space.

2.3 Material of Boiler

The pressure vessel in a boiler is usually made of steel or alloy steel, or historically of wrought iron. Stainless steel is virtually prohibited by the ASME Boiler Code for use in wetted parts of modern boilers, but is used often in super heater sections that will not be exposed to liquid boiler water. In live steam models, copper or brass is often used because it is more easily fabricated in smaller size boilers. Historically, copper was often used for fireboxes particularly for steam locomotives, because of its better formability and higher thermal conductivity, however, in more recent times, the high price of copper often makes this an uneconomic choice and cheaper substitutes such as steel are used instead.

For much of the Victorian age of steam, the only material used for boiler making was the highest grade of wrought iron, with assembly by riveting. This iron was often obtained from specialist ironworks, such as at Cleator Moor, noted for the high quality of their rolled plate and its suitability for high reliability use in critical applications, such as high pressure boilers. In the 20th century, design practice instead moved towards the use of steel, which is stronger and cheaper, with welded construction, which is quicker and requires less labour.

Cast iron may be used for the heating vessel of domestic water heaters. Although such heaters are usually termed boilers, their purpose is usually to produce hot water, not steam, and so they run at low pressure and try to avoid actual boiling.

2.4 Fuel for Boiler

The source of heat for a boiler is combustion of any of several fuels, such as wood, coal, oil, or natural gas. Electric steam boilers use resistance or immersion type

heating elements. Nuclear fission is also used as a heat source for generating steam. Heat recovery steam generators use the heat rejected from other processes such as gas turbines.

2.5 Safety in Boiler

Historically, boilers were a source of many serious injuries and property destruction due to poorly understood engineering principles. Thin and brittle metal shells can rupture, while poorly welded or riveted seams could open up, leading to a violent eruption of the pressurized steam. Collapsed or dislodged boiler tubes could also spray scalding-hot steam and smoke out of the air intake and firing chute, injuring the firemen who loaded coal into the fire chamber. Extremely large boilers providing hundreds of horsepower to operate factories could demolish entire buildings.

A boiler that has a loss of feed water and is permitted to boil dry can be extremely dangerous. If feed water is then sent into the empty boiler, the small cascade of incoming water instantly boils on contact with the superheated metal shell and leads to a violent explosion that cannot be controlled even by safety steam valves. Draining of the boiler could also occur if a leak occurred in the steam supply lines that were larger than the make-up water supply could replace. The Hartford Loop was invented in 1919 by the Hartford Steam Boiler and Insurance Company as a method to help prevent this condition from occurring, and thereby reduce their insurance claims.

2.6 Applications

Boilers have many applications in the industries, research and development, etc. Some are listed below:

- □ They can be used in stationary applications to provide heat, hot water, or steam for domestic use, or in generators.
- They can be used in mobile applications to provide steam for locomotion in applications such as trains, ships, and boats.
- Using a boiler is a way to transfer stored energy from the fuel source to the water in the boiler, and then finally to the point of end use.
- Some steam boats, particularly smaller types such as river launches, were designed around a vertical boiler.

- The Sentinel Waggon Works also produced a range of road lorries also known as steam wagons, based on their high-pressure vertical boilers.

2.7 Boiler Steam Drum Level Control Systems

Boiler is used in many process industries. Control of various parameters of boiler is required for its proper functioning. There are mainly three parameters which are to be controlled, that are, steam out flow, level of fluid, and feed water flow. Pressure, temperature and level cannot be controlled, the only thing that can be controlled is flow. The pressure or temperature in a boiler is maintained by controlling the flow of fuel and air. Also, the level is maintained by controlling the flow of feed water. Pressure, temperature, level, and other measures will increase or decrease only with a change in flow. The purpose of the drum level controller is to bring the drum up to level at boiler start-up and maintain the level at constant steam load.

Single-element drum level control system is the simplest approach of level control of boiler. It measures level and regulates feedwater flow to maintain the level. This system is only effective for smaller boilers supplying steady processes which have slow and moderate load changes. This is because shrink and swell causes an incorrect initial control reaction. As steam demand increases, lowering the pressure, the drum level increases sending a false control signal to reduce feedwater flow when actually the feedwater flow should increase to maintain mass balance. Similarly when steam demand decreases, the drum level decreases sending a false control signal to increase the feedwater flow when actually the feed-water flow should decrease to maintain mass balance. More complex systems are required to handle significant shrink and swell effects.

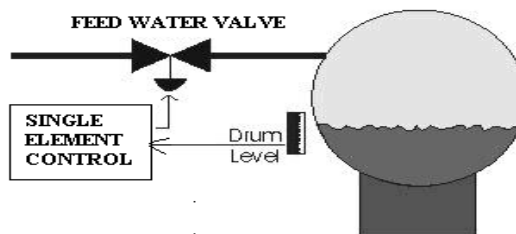

Figure 2.5: Single Element Drum Level Control

Figure 2.5 shows the control scheme of single element drum level control of boiler

Two element drum level control system is suitable for processes with moderate load swings and can be used on any size boiler. The two element drum level control uses two variables, drum level and steam flow to manipulate the feedwater control valve. Steam flow load changes are fed forward to the feedwater control valve. The steam flow range and feedwater flow range are matched so that a one pound change in steam flow results in a one pound change in feedwater flow. The summer combines the steam flow signal with the feedback action of the drum level controller which makes trim adjustments in feedwater flow, as required, to compensate for unmeasured blowdown losses and steam flow measurement errors. Two element control is adequate for load changes of moderate speed and magnitude, and it can be applied to any size boiler. It has a drawback which must be considered. It cannot adjust for pressure or load disturbances in the feedwater system. If these disturbances are a concern, than three element drum level control can correct the drawbacks.

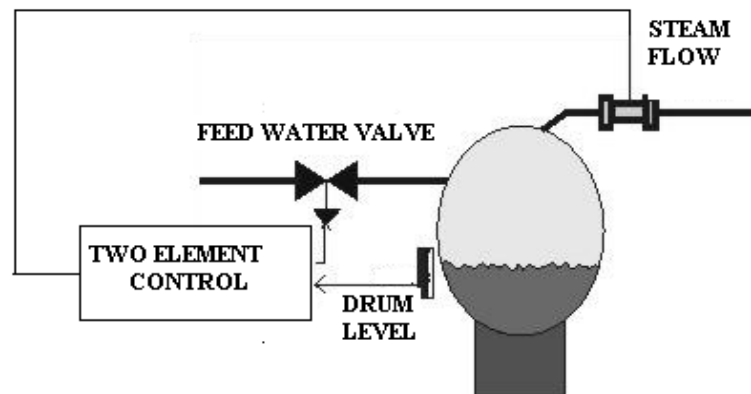

Figure 2.6: Two Element Drum Level Control

Figure 2.6 shows the control scheme of two element drum level control of industrial boiler. Three-element drum level control system adds a third variable, feedwater flow rate, to manipulate the feedwater control valve. This system basically cascades the summer output of the two element system to the feedwater flow controller as a remote set point signal. This system provides close control during transient condition. The addition

of the faster feedwater secondary loop assures an immediate correction for feedwater disturbances. The drum level controller accurately compensates for effects of smaller unmeasured flows such as blowdown and mismatch between the two flow measurements. As in the two element system, nearly all the compensation for load changes is handled by the feedforward portion while the drum level feedback loop provides only trimming action. This system can handle large and rapid load changes and feedwater disturbances regardless of boiler capacity. This approach is required on multiple boilers having a common feedwater supply. It is ideal for plants with both batch and continuous processes where sudden and unpredictable steam demand changes are common.

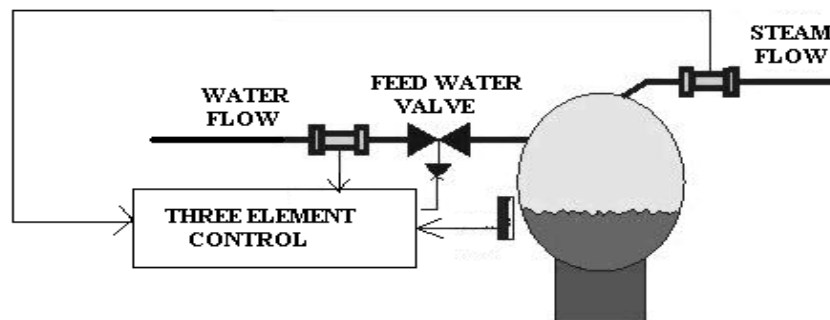

Figure 2.7: Three Element Drum Level Control

Figure 2.7 shows the control scheme of three element drum level control of boiler.

2.8 Control Structure of Proposed System

To analyze the behavior of three element drum level control system, a simulink model is designed. In that various blocks are attached such as PID controller block, fractional PID controller, fuzzy PID controller which works as primary controller, PI controller which works as secondary controller, feedforward controller, saturation block, transfer function block, step block, multiplexer block etc.

2.9 Types of Controller

There are different types of controller in an industry. Some of them are listed below:

1. Feedback Controller

2. Feedforward Controller
3. Cascade Controller

2.9.1 Feedback Controller

In a feedback controller output is compared with the input and error is calculated. The output is fed back to the input so that an appropriate control action should be taken as a function of output and input. The feedback is always negative to reduce the error. Negative feedback also gives better stability in steady state and rejects any disturbance signal. It also has a low sensitivity to the parameter variations.

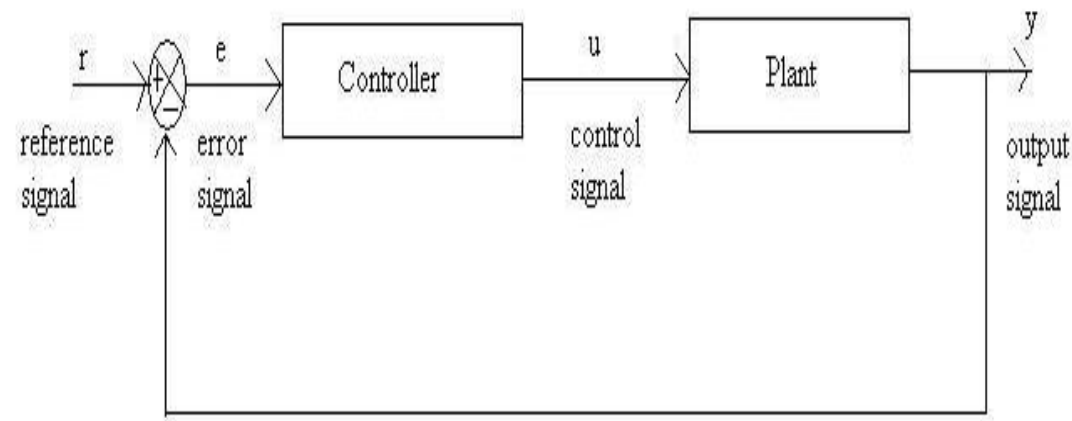

Figure 2.8: Feedback Control Loop

2.9.1.1 Advantages of Feedback Control

- Corrects the controlled variable regardless of the source and type of disturbance.
- Requires minimal knowledge about the process.

2.9.1.2 Disadvantages of Feedback Control

- Corrective action is taken only after a deviation in the controlled variable occurs.
- It does not provide predictive control action to compensate for the effects of known or measurable disturbances.
- May not be satisfactory for processes with large time constants and/or long time delays.
- Not feasible where the controlled variable cannot be measured on-line.

2.9.1.3 Applications of Feedback Control

- Flow control
- Liquid level control
- Pressure and Temperature control

2.9.2 Feedforward Controller

The basic concept of the feed forward controller is to measure the disturbances and take corrective action before the disturbance can upset the process.

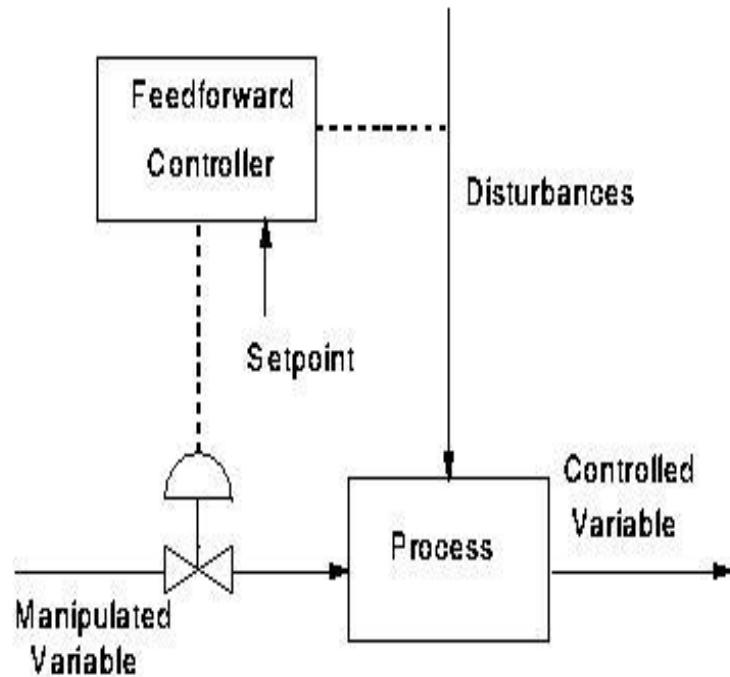

Figure 2.9: Schematic Diagram of Feedforward Control

2.9.2.1 Advantages of Feedforward Control

- Compensates for disturbance before output is affected.
- Does not affect the stability of the control system.

2.9.2.2 Disadvantages of Feedforward Control

- The disturbance variable must be measured on line. In many applications it is not feasible.

- For feed forward controller at least an approximate process model should be available.
- Ideal feed forward controller which is theoretically possible may not be practically implemented.

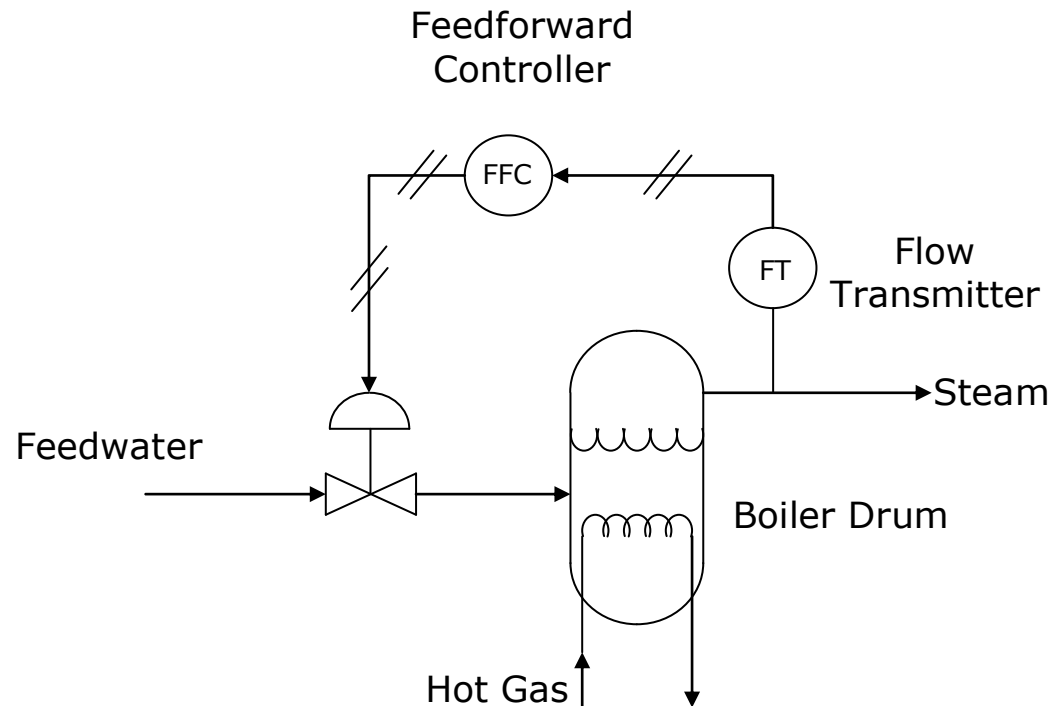

Figure 2.10: Example of Feedforward Control

2.9.3 Cascade Controller

In a cascade control, there are two or more controllers of which one controller's output drives the set point of another controller. For example, a level controller driving the set point of a flow controller to keep the level at its set point. The flow controller, in turn, drives a control valve to match the flow with the set point the level controller is requesting. The controller driving the set point is called the primary, outer, or master controller. The controller receiving the set point is called the secondary, inner or slave controller. Cascade control is beneficial only if the dynamics of the inner loop are fast compared to those of the outer loop.

2.9.3.1 Advantages of Cascade Control

- Better control of the primary variable.
- Primary variable less affected by disturbances.
- Faster recovery from disturbances.

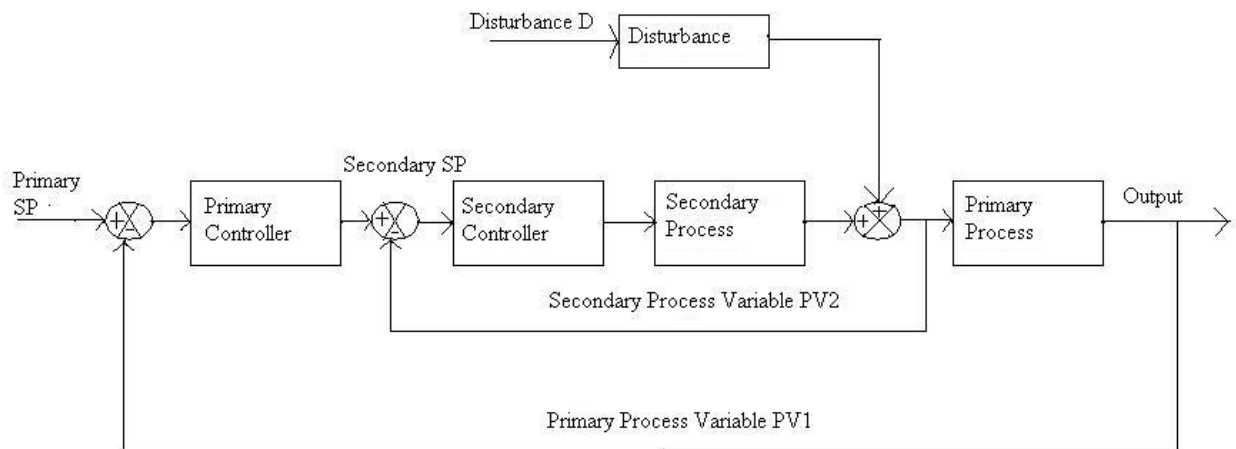

Figure 2.11: Schematic Diagram of Cascade Control

2.9.3.2 Disadvantages of Cascade Control

- It is not affected if the secondary variable is not faster than primary variable.
- Multiple control loops make physical and computational architecture more complex.
- Additional controllers and sensors can be costly.

2.10 PID Controller

The Proportional-Integral-Derivative (PID) controllers have been the most commonly used controller in process industries for over 50 years even though significant development have been made in advanced control theory. According to a survey conducted by Japan Electric Measuring Instrument Manufacturers Association in 1989, 90 % of the control loops in industries are of the PID type. The proportional action adjusts controller output according to the size of the error, the integral action eliminates the steady state offset and the future is anticipated via derivative action. These useful

functions are sufficient for a large number of process applications and the transparency of the features lead to wide acceptance by the users. Strength of the PID controller is that it also deals with important practical issues such as actuator saturation and integrator windup. PID controllers perform well for a wide class of processes and they give robust performance for a wide range of operating conditions and are easy to implement using analog or digital hardware. Moreover, due to process uncertainties, a more sophisticated control scheme is not necessarily more efficient than a well tuned PID controller.

A large industrial process may have hundreds of PID controllers. Proper tuning of the controllers is crucial for achieving the desired response characteristics. They have to be tuned individually to match the process dynamics in order to provide good and robust control performance. The tuning procedure, if done manually, is very tedious and time consuming; the resultant system performance mainly depends on the experience and the process knowledge of the engineers. It is recognized that in practice, many industrial control loops are poorly tuned. However with the advent of the auto-tuning of PID controller concept, this problem has been solved to a considerable extent. Automatic tuning techniques thus draw more and more attention of the researchers and practicing engineers. By automatic tuning, we mean a method which enables the controller to be tuned automatically on demand from an operator or an external signal. Typically, the user will either push a button or send a command to the controller. Industrial experience has clearly indicated that this is highly desirable and useful feature.

$$u(t) = K_p e(t) + K_d \frac{de(t)}{dt} + K_i \int_0^t e(t) dt \quad (1)$$

PID control is a name commonly given to three-term control. The mnemonic PID refers to the first letters of the names of the individual terms that make up the standard three-term controller. These are P for the proportional term, I for the integral term and D for the derivative term in the controller. Three-term or PID controllers are probably the most widely used industrial controller. Even complex industrial control systems may comprise a control network whose main control building block is a PID control module. The three-term PID controller has had a long history of use and has survived the changes of technology from the analogue era into the digital computer control system age quite satisfactorily. It was the first and the only controller to be mass produced for the high

volume market that existed in the process industries. The introduction of the Laplace transform to study the performance of feedback control systems supported its technological success in the engineering community. The theoretical basis for analyzing the performance of PID control is considerably aided by the simple representation of an Integrator by the Laplace transform, $1/s$, and a Differentiator using s . Conceptually, the PID controller is quite sophisticated and three different representations can be given. First, there is a symbolic representation, where each of the three terms can be selected to achieve different control actions. Secondly, there is a time domain operator form, and finally, there is a Laplace transform version of the PID controller. This gives the controller an s -domain operator interpretation and allows the link between the time domain and the frequency domain to enter the discussion of PID controller performance.

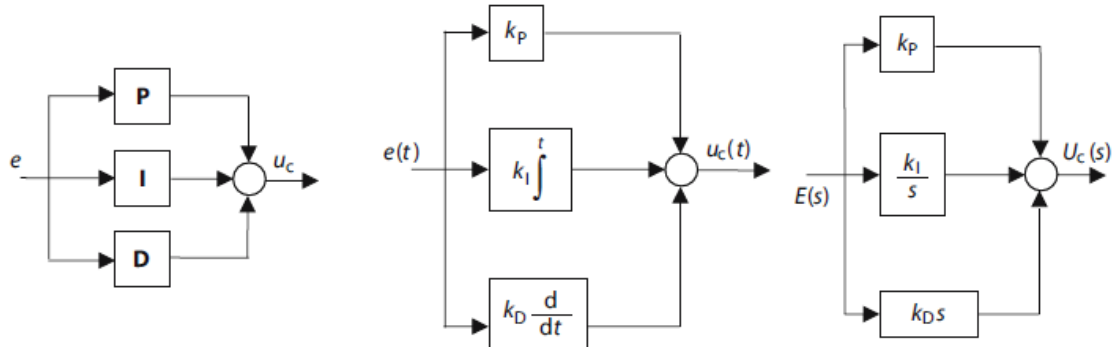

Figure 2.12: PID Controller Architecture in Time Domain and Laplace Domain

2.11 Fractional Order Calculus

The concept of fractional order controller means controllers can be described by fractional order differential equations. A commonly used definition of the fractional calculus is the Riemann-Liouville definition.

$$D_t^\nu f(t) = \begin{cases} \frac{1}{\Gamma(-\nu)} \int_a^t (t-x)^{-\nu-1} f(x) dx & \nu < 0 \\ \frac{d^n f}{dt^n} & a = n \in \mathbb{N} \\ \frac{d^n}{dt^n} [D_t^{-(n-\alpha)} f(t)] & 0 \leq n-1 < \alpha < n \\ \frac{1}{\Gamma(n-\alpha)} \frac{d^n}{dt^n} \left[\int_a^t \frac{f(\tau)}{(t-\tau)^{\alpha-n+1}} d\tau \right] & \end{cases} \quad (2)$$

for $(m-1 < \alpha < m)$ and where $\Gamma(\cdot)$ is the well-known Euler's gamma function. An alternative definition, based on the concept of fractional differentiation, is the Grunwald-Letnikov definition given by

$${}_a D_t^\alpha f(t) = \lim_{h \rightarrow 0} \frac{1}{\Gamma(\alpha)h^\alpha} \sum_{k=0}^{(t-\alpha)/h} \frac{\Gamma(\alpha+k)}{\Gamma(k+1)} f(t-kh) \quad (3)$$

By introducing notion of the fractional order operator ${}_a D_t^\alpha f(t)$, the differentiator and integrator can be unified.

Another useful tool is the Laplace transform. It is shown in the Laplace transform.

$$L\{D^{-\alpha} f(t)\} = s^{-\alpha} F(s) \quad (4)$$

$$L\{D^\alpha f(t)\} = s^\alpha F(s) - \sum_{k=0}^{n-1} s^k \left[D^{\alpha-k-1} f(t) \right]_{t=0} \quad (5)$$

$$(n-1 \leq \alpha \leq n)$$

2.12 Fractional Order Controller

A fractional order differential equation, provided both the signals $u(t)$ and $y(t)$ are relaxed at $t=0$, can be expressed in the transfer function form

$$G(s) = \frac{a_1 s^{\alpha_1} + a_2 s^{\alpha_2} + \dots + a_{m_\lambda} s^{\alpha_{m_\lambda}}}{b_1 s^{\beta_1} + b_2 s^{\beta_2} + \dots + b_{m_\beta} s^{\beta_{m_\beta}}} \quad (6)$$

where $a_m, b_m \in \mathbb{R}^2$, $\alpha_m, \beta_m \in \mathbb{R}^2$, for all $m \in N$

Transfer function of fractional order PID

$$G_{FOPID}(s) = \frac{u(s)}{e(s)} = K_c \left(1 + \frac{1}{\tau_i s^\lambda} + \tau_d s^\mu \right) \quad (7)$$

Where K_p is the proportional constant, T_I is the integration constant, T_D is the differentiation constant, the fractional integration action order λ and μ is the fractional differentiation action order.

2.13 Transient Response of PID Controller

Following figure shows the transient response of PID controllers.

The below figure 2.13 shows the unit step response of second order system by varying the values of K_p and keeping the values of K_i and K_d constant.

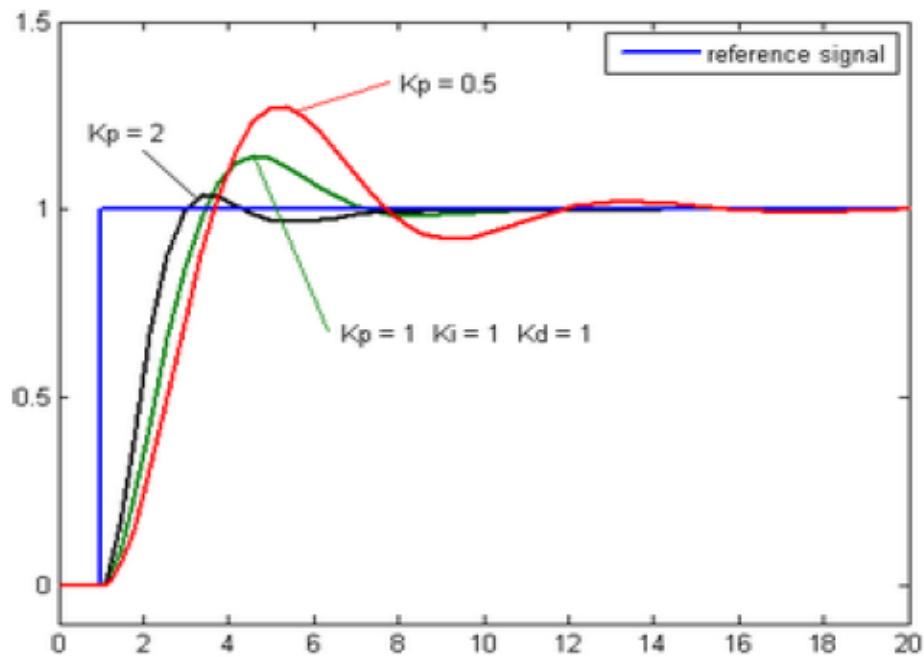

Figure 2.13: Plot of PV v/s Time of Second Order System for Three Values of K_p

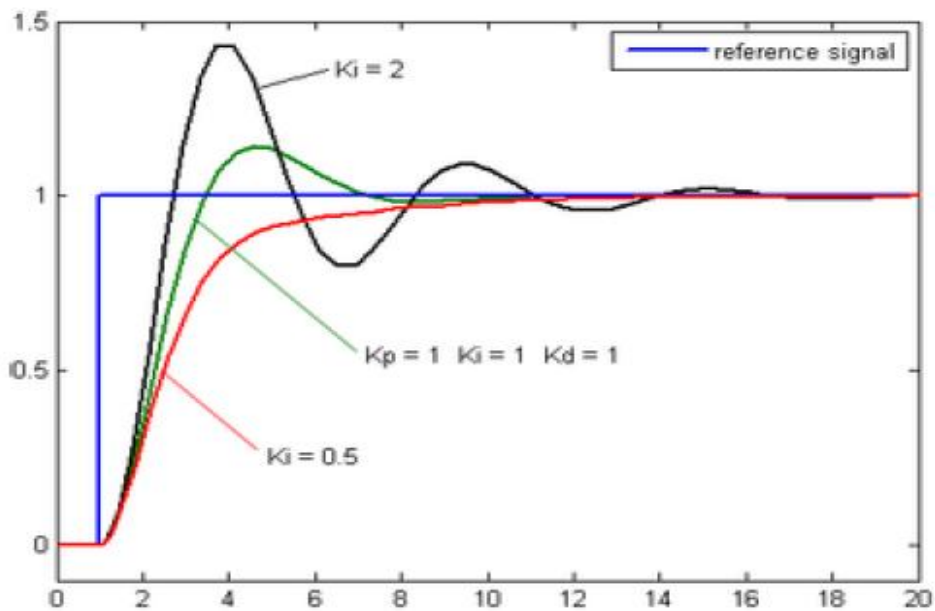

Figure 2.14: Plot of PV v/s Time of Second Order System for Three Values of K_i

The above figure 2.14 shows the unit step response of second order system by varying the values of K_i and keeping the values of K_p and K_d constant.

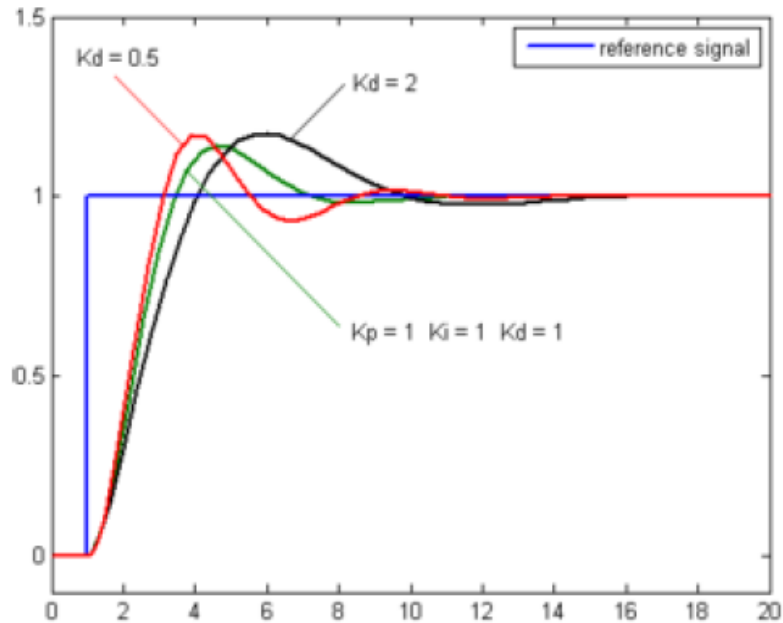

Figure 2.15: Plot of PV v/s Time of Second Order System, for Three Values of K_d

The above figure 2.15 shows the unit step response of second order system by varying the values of K_d and keeping the values of K_p and K_i constant.

Table 2.1: Key Characteristics of Commercial PID Controller

Controller Feature	Controller Parameter	Symbol	Units	Typical Range
P mode	Controller Gain	K_c	Dimensionless	0.1 – 100
	Proportional Band	$PB = 100 / K_c$	%	1 – 1000%
I mode	Integral Time	T_i	Time	0.002-20 min, 1-1000s
	Reset Rate	$1/T_i$	Repeats/time	0.001 repeats/s, 0.06- 6 repeats/m
	Integral Mode Gain	K_i	Time^{-1}	0.1-100
	Derivative Time	T_d	Time	0.1-10 min, 5-500 s
	Derivative	K_d	Time	0.1-100

D mode	Mode Gain			
	Derivative Filter Parameter		Dimensionless	0.05-0.2
Control Interval		D_t	Time	0.1s-10 min

The above table 2.1 shows the characteristics of the proportional mode, derivative mode and integral mode of the commercial PID controller.

2.14 Tuning the PID Controller

The second part of setting up a PID controller is to tune or choose numerical values for the PID coefficients. Many industrial process companies have in-house manuals that provide guidelines for the tuning of PID controllers for particular process plant units. Thus for simple processes it is often possible to provide rules and empirical formulae for the PID controller tuning procedure. Some of these manuals base their procedures on the pro forma routines of the famous Ziegler–Nichols methods and their numerous extensions of the associated rules. The two Ziegler–Nichols methods use an on-line process experiment followed by the use of rules to calculate the numerical values of the PID coefficients. In the 1980s, when analogue control was being replaced by digital processing hardware, industrial control companies took the opportunity to develop new PID controller methods for use with the new ranges of controller technology appearing. Consequently, the Ziegler–Nichols methods became the focus of research and have since, become better understood. New versions of the Ziegler–Nichols procedures were introduced, notably the Åström and Hägglund relay experiment. In many applications, the implicit underdamped closed-loop performance inherent in the original Ziegler–Nichols design rules was found to be unacceptable. The result was an extensive development of the rule-base for PID controller tuning. O’Dwyer has published summaries of a large class of the available results. Continuing competitive pressures in industry have led to a constant need for continual improvements in control loop

performance. One result of these trends is that industry is much better at being able to specify the type of performance that a control system has to deliver.

2.15 Ziegler-Nichols Tuning

In 1942, Ziegler and Nichols, both of them are the employees of Taylor Instruments. They described simple mathematical procedures in the form of the first and second methods, for tuning PID controllers. These procedures are now accepted as standard in control systems practice. Both techniques make a priori assumptions on the system model, but do not require that these models be specifically known. Ziegler-Nichols formulae for specifying the controllers are based on plant step responses. There are two methods of Ziegler-Nichols tuning:

- First method
- Second method

These methods are explained in the following sections:

2.15.1 First Method

The first method is applied to plants with step responses of the form displayed in figure 2.16. This type of response is typical of a first order system with transportation delay, such as that induced by fluid flow from a tank along a pipe line. It is also typical of a plant made up of a series of first order systems. The response is characterized by two parameters, L the delay time and T the time constant. These are found by drawing a tangent to the step response at its point of inflection and noting its intersections with the time axis and the steady state value. The plant model is therefore

$$G(s) = \frac{Ke^{-sL}}{Ts + 1} \quad (8)$$

where:

G(s) = Transfer function of the process

K = Gain of the process

T = Time constant of the process

Ziegler and Nichols derived the following control parameters based on this model:

Table 2.2: Ziegler-Nichols Recipe: First Method

PID Type	K_p	$T_i=K_p/K_i$	$T_d=K_d/K_p$
P	$\frac{T}{L}$	∞	0
PI	$0.9\frac{T}{L}$	$\frac{L}{0.3}$	0
PID	$1.2\frac{T}{L}$	$2L$	$0.5L$

In the above table 2.2, proportional gain, integral time and derivative time for different controller types are derived using ultimate gain and ultimate period using Ziegler-Nichols first method.

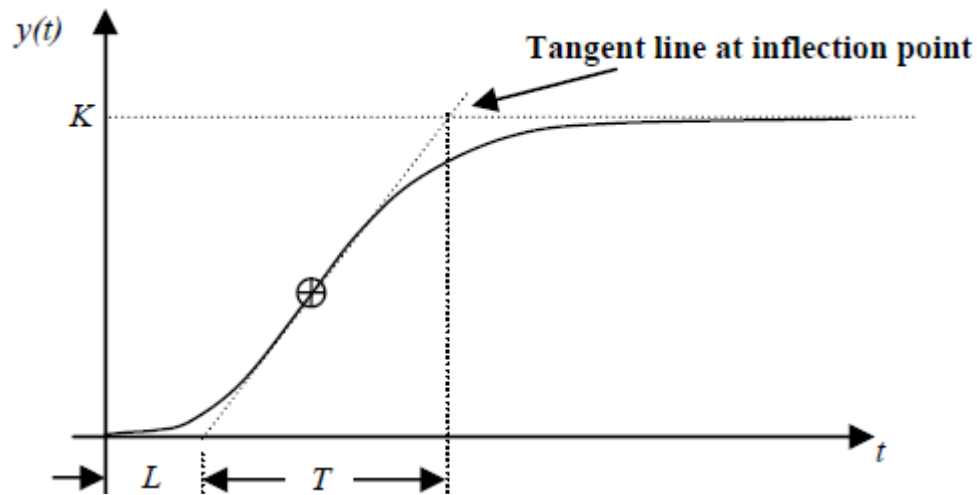

Figure 2.16: Response Curve for Ziegler-Nichols First Method

The above figure 2.16 shows the response curve. This response curve is of typical over damped second order system.

2.15.2 Second Method

The second method targets plants that can be rendered unstable under proportional control. The technique is designed to result in a closed loop system with 25% overshoot. This is rarely achieved as Ziegler and Nichols determined the adjustments based on a specific plant model.

The steps for tuning a PID controller via the 2nd method are as follows:

Using only proportional feedback control:

- Reduce the integrator and derivative gains to 0.
- Increase K_p from 0 to some critical value $K_p=K_{cr}$ at which sustained oscillations occur. If it does not occur then another method has to be applied.
- Note the value K_{cr} and the corresponding period of sustained oscillation, P_{cr} .

The controller gains are now specified as follows:

Table 2.3: Ziegler Nichols Recipe: Second Method

PID Type	K_p	T_i	T_d
<i>P</i>	$0.5K_{cr}$	∞	0
<i>PI</i>	$0.45K_{cr}$	$\frac{P_{cr}}{1.2}$	0
<i>PID</i>	$0.6K_{cr}$	$\frac{P_{cr}}{2}$	$\frac{P_{cr}}{8}$

In the above table 2.3, proportional gain, integral time and derivative time for different controller types are derived using ultimate gain and ultimate period using Ziegler-Nichols second method.

Summary

This chapter discusses the various types of boilers, its materials and the fuel used for the boilers. It also discusses the different types of control strategies and the controllers used for the level control of boiler steam drum. To find the optimum values of K_p , T_i and T_d of PID controller, Ziegler-Nichols tuning method can be used. In Ziegler-Nichols tuning method, by using ultimate gain and ultimate period, optimum values of K_p , T_i and T_d can be calculated.

Chapter 3

Literature Review

John P McDonald et.al, (1973), developed an optimal linear regulator theory for boiler-turbine-generator which recognizes the limitation of the imperfection of the model. [2]

B J Huang et.al, (1994), developed a system dynamic model of fire tube shell boiler. [5]

Hugh F. VanLandingham et.al, (1996), has proposed the three element control of boiler by introducing first by PID controller then by Fuzzy controller. This scheme worked satisfactorily in the absence of any process disturbances. They has presented model-free approach in the sense that no plant equations are assumed. Based on this process knowledge, an intelligent control technique, fuzzy logic control, was developed. They had used simulator to see the response. Intelligent control technique is used for the control of drum level in a steam generator boiler system. Better performance compared to the existing 3-element PID control scheme in dealing with the process disturbances. [6]

Y Huang et.al, (2006), developed a GA based adaptive control for drum level of power plant boiler. [18]

Dingyu Xue et.al, (2006), has proposed fractional order PID control of DC motor with elastic shaft. The simulation results have shown that if fractional order PID controller is properly designed and implemented, it can outperform conventional integer order PID controller. [24]

Deepyaman Maiti et.al, (2008), used particle swarm optimization technique to

tune fractional order PID controller. Controller synthesis is based on required peak overshoot and rise time specifications. Experimental results have shown that this optimization technique can tune the controller effectively. Using fractional order PID controllers, percentage overshoot, rise time and settling time have significantly reduced as compared to integral PID controllers. [26]

Varsha Bhambhani et.al (2008) has presented comparative experimental study on coupled-tank liquid level control using fractional order PI control and integer order PI control. Tuning of integer order PI control and fractional order PI control has been done using Ziegler and Nichols tuning method. Experimental results confirmed that fractional order PI controller is a promising controller in terms of percentage overshoot and system response in liquid-level control in face of nonlinearities introduced by pumps, valves and sensors. [28]

Chuang Zhao et.al (2008), has proposed a fractional order PID controller to control a servo system. FPID's experimental time response is compared with model predictive control. Theoretical analysis and experimental analysis are compared which shows the effectiveness of fractional order PID control. [32]

Jin-Sung Kim et.al (2008), has presented a control scheme composing an auto tuning stochastic technique based on an improved Genetic Algorithm (GA) is proposed. For better evaluation of the process in GA, objective function defined newly in sense of root mean square error has been used. Also in order to achieve better performance of GA, more pureness and longer period of random number generation in operation are sought. The main improvement is made by replacing the uniform distribution random number generator in conventional GA technique to newly designed hybrid random generator composed of Cauchy distribution and linear congruential generator, which provides independent and different random numbers at each individual steps in genetic operation. [34]

Hamid Bentarzi et.al, (2009), presents a new method for controlling fuel and air

fed boiler of thermal power plant using Fuzzy logic. The control strategy is based on supervisor level using Fuzzy logic that is required to determine automatically the optimal process set points of regulations level. [36]

Juan Garrido et.al, (2009), deals with control of non linear boiler turbine unit with great interactions, hard constraints and rate limits imposed on the actuator. [37]

Venu Kishore Kadilaya et.al, (2009), has proposed a fractional order PID controller to control aerofin position. Researchers have used the particle swarm optimization to tune the fractional order PID controller of electromagnetic actuator system for aerofin control. The design parameters which are optimized are rise time, peak time and percentage overshoot. Experimental results have shown that the transient response and closed loop response using particle swarm optimization based tuning of FOPID is better when compared to that of conventional methods and untuned system. [38]

Yue Wei-Jie et.al, (2009), described a fuzzy self adapting PID controller for boiler drum level controller and compared the self adapting PID controller with PID controller and concluded that the self adapting PID controller gives a better result. [39]

Zang Haihe et.al, (2010), has developed a fuzzy logic based controller of drum water level for industrial boiler. [40]

Liang Chen et.al, (2010), has proposed the control theory of self-adaptable fuzzy-PID controller. The self-adaptable fuzzy-PID control method is applied in automatic control of boiler drum water level, under the situation of interaction and no interaction. The simulation is done to PID controller and self-adaptable fuzzy-PID controller and the result have shown that the application of self-adaptable fuzzy-PID controller is better than PID controller. [42]

Chapter 4

Fuzzy Logic: An Overview

4.1 Fuzzy Logic: Introduction

Fuzzy Logic is extension of boolean logic. It incorporates partial values of truth. Instead of sentences being completely true or completely false, here in fuzzy logic they are assigned a value which represents their degree of truthness. In fuzzy systems, values are indicated by a number called as truth value. It lies in the range from 0 to 1. 0.0 represents absolute falseness and 1.0 represents absolute truth. Fuzzification is generalization of theory from discrete to continuous. Fuzzy logic is important to artificial intelligence. Fuzzy logic allows computers to answer to a certain degree unlike Boolean logic which gives one extreme or the other. Computers are allowed to think more human-like. Nothing in our perception is extreme. However, it is true only to a certain degree. In fuzzy logic, machines think in degrees. It can solve problems in the cases where there is no simple mathematical model. Fuzzy logic solves highly nonlinear processes. Fuzzy logic uses expert knowledge to make decisions.

Fuzzy logic was first invented as a representation scheme. It acts as calculus for uncertain or vague notions. It allows more human-like interpretations. Fuzzy logic has put reasoning in machines by resolving intermediate categories between notations like true/false, hot/cold etc. Fuzzy logic is a problem-solving control system methodology. It lends itself to implementation in systems ranging from small, simple, embedded micro-controllers to large, multi-channel, networked PC or workstation-based data acquisition control systems etc. It can be implemented in software, hardware, or a combination of both. Fuzzy logic provides a simple way to arrive at a definite conclusion. Conclusion is based upon ambiguous or vague, noisy, imprecise, or missing input information. Fuzzy logic's approach to control problems simply mimics how a person will make efficient decisions much faster.

In 1965, Professor L.A. Zadeh of the University of California, Berkely presented his paper outlining fuzzy theory in which he introduced the concept of fuzzy set theory and

operation, fuzzy logic based controller etc. In about 1970, fuzzy logic theory began to produce result in Japan, Europe and China. In the year 1987, 16 station subway railway systems were built which worked with a fuzzy logic-based automatic train operation control system in sendai, japan. The ride is so smooth that the riders do not need to hold straps, and the controller makes seventy percent fewer judgmental errors in acceleration and braking than human operators do. Fuzzy logic is a powerful problem-solving methodology with a myriad of applications in embedded control and information processing. Fuzzy provides a remarkably simple way to draw definite conclusions from vague, ambiguous or imprecise information. In a sense, fuzzy logic resembles human decision making with its ability to work from approximate data and find precise solutions. Unlike classical logic, which requires a deep understanding of a system, exact equations, and precise numeric values, fuzzy logic incorporates an alternative way of thinking, which allows modelling complex systems using a higher level of abstraction originating from our knowledge and experience. Fuzzy logic allows expressing this knowledge with subjective concepts such as very hot, bright red, and a long time, which are mapped into exact numeric ranges.

Fuzzy logic is a paradigm for an alternative design methodology, which can be applied in developing both linear and non-linear systems for embedded control. Fuzzy logic provides an alternative solution to non-linear control because it is closer to the real world. Rules, membership functions, and the inference process which results in improved performance, simpler implementation, and reduced design costs handle non-linearity. By using fuzzy logic, designers can realize lower development costs, superior features, and better end product performance. Furthermore, products can be brought to market faster and more cost-effectively. Fuzzy logic has been gaining increasing acceptance during the past few years. There are over two thousand commercially available products using fuzzy logic, ranging from washing machines to high-current trains. Nearly every application can potentially realize the benefits of fuzzy logic.

4.2 Fuzzy Logic: A Choice to All Control Problems

Fuzzy logic offers several unique features that make it a particularly good choice for many control problems.

- It is inherently robust since it does not require precise, noise-free inputs and can be programmed to fail safely if a feedback sensor quits or is destroyed. The output control is a smooth control function despite a wide range of input variations.
- Since the fuzzy logic controller processes user-defined rules governing the target control system, it can be modified and tweaked easily to improve or drastically alter system performance. New sensors can easily be incorporated into the system simply by generating appropriate governing rules.
- Fuzzy logic is not limited to a few feedback inputs and one or two control outputs, nor is it necessary to measure or compute rate-of-change parameters in order for it to be implemented. Any sensor data that provides some indication of a system's actions and reactions is sufficient. This allows the sensors to be inexpensive and imprecise thus keeping the overall system cost and complexity low.
- Because of the rule-based operation, any reasonable number of inputs can be processed and numerous outputs generated, although defining the rule base quickly becomes complex if too many inputs and outputs are chosen for a single implementation since rules defining their interrelations must also be defined. It would be better to break the control system into smaller chunks and use several smaller fuzzy logic controllers distributed on the system, each with more limited responsibilities.
- Fuzzy logic can control nonlinear systems that would be difficult or impossible to model mathematically.

4.3 Fuzzy Logic: Can Implement in All Control Problems

- Define the control objectives and criteria: What am I trying to control? What do I have to do to control the system? What kind of response do I need? What are the possible system failure modes?
- Determine the input and output relationships and choose a minimum number of variables for input to the fuzzy logic engine, typically that are error and rate of change of error.

- Using the rule-based structure of fuzzy logic, break the control problem down into a series of IF X AND Y THEN Z rules that define the desired system output response for given system input conditions. The number and complexity of rules depends on the number of input parameters that are to be processed and the number fuzzy variables associated with each parameter. If possible, use at least one variable and its time derivative. Although it is possible to use a single, instantaneous error parameter without knowing its rate of change, this cripples the system's ability to minimize overshoot for a step inputs.
- Create fuzzy logic membership functions that define the meaning or values of Input/Output terms used in the rules.
- Test the system, evaluate the results, tune the rules and membership functions, and retest until satisfactory results are obtained.

4.4 Fuzzy Logic: Operations

Fuzzy logic requires some numerical parameters in order to operate such as what is considered significant error and significant rate of change of error, but exact values of these numbers are usually not critical unless very responsive performance is required in which case empirical tuning would determine them.

4.5 Fuzzy Logic: Types

- Type I Fuzzy Set
- Type II Fuzzy Set

These two types of fuzzy sets are explained in the following sections:

4.5.1 Type I Fuzzy Set

Let X be a collection of objects called universe of discourse. A fuzzy set $A \in X$ is characterized by membership function $\mu_A(x)$ which represents the degree of membership. Degree of membership maps each element between 0 and 1. It is defined as:

$$A = \{(x, \mu_A(x)); x \in X\} \quad (9)$$

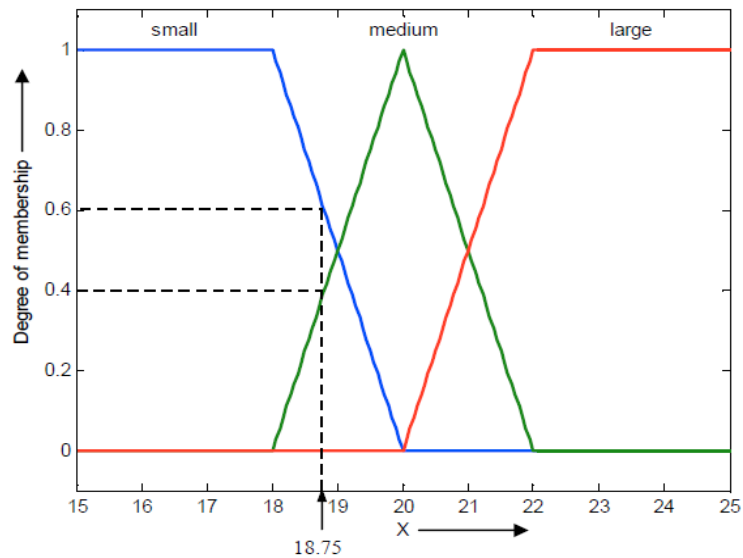

Figure 4.1: Fuzzy Logic Membership Function

The above figure 4.1 shows the triangular membership function with three linguistic variables as small, medium and large. For $X = 18.75$, degree of membership for small is 0.6 and degree of membership for medium is 0.4.

4.5.2 Type II Fuzzy Set

The type-2 fuzzy set model makes use of an extra third dimension. These sets are typically implemented as points stored in an array. Type-2 fuzzy logic requires two different levels of discretisation: for the primary and secondary membership functions. In the case of generalized type-2 membership functions, where the secondary is a type-1 fuzzy number, the computational complexity is very large.

4.6 Fuzzy Inference System

Fuzzy inference systems (FIS) are rule-based systems. It is based on fuzzy set theory and fuzzy logic. FIS are mappings from an input space to an output space. FIS allows constructing structures which are used to generate responses or outputs for certain stimulations or inputs. Response of FIS is based on stored knowledge or relationships between responses and stimulations. Knowledge is stored in the form of a rule base. Rule base is a set of rules. Rule base expresses relations between inputs of system and its expected outputs.

Knowledge is obtained by eliciting information from specialists. These systems are usually known as fuzzy expert systems. Another common denomination for FIS is fuzzy knowledge-based systems. It is also called as data-driven fuzzy systems. FIS are usually divided in two categories viz. multiple input and multiple output (MIMO) systems and multiple input and single output (MISO) systems, the system returns several outputs based on the inputs which it receives. Multiple input and single output systems are those where only one output is returned from multiple inputs. MIMO systems are decomposed into a set of MISO systems which work in parallel.

In terms of inference process there are two main classes of FIS:

1. Mamdani-type FIS
2. Takagi-Sugeno- Kang (TSK) type FIS

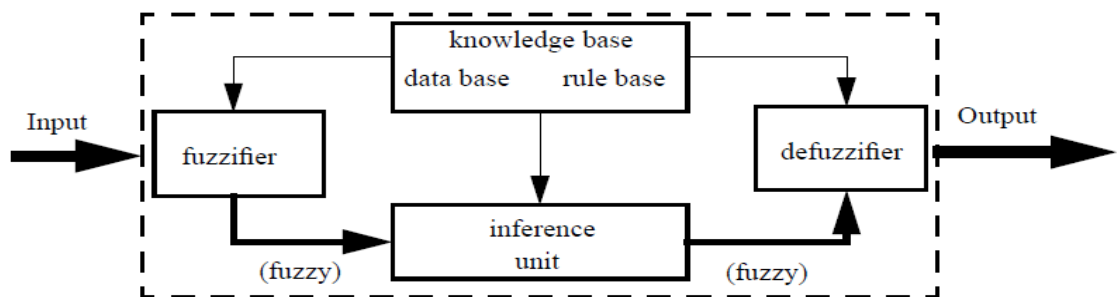

Figure 4.2: Block Diagram of Fuzzy Logic System

The above figure 4.2 shows the block diagram of fuzzy logic system. It has different blocks: fuzzifier, knowledge base, inference unit and defuzzifier.

4.6.1 Mamdani Based FIS

In mamdani based fuzzy inference system, inputs and outputs have an If-Then rules. A typical rule in a sugeno fuzzy model is: IF X is Negative Big AND Y is Negative Small THEN Z is Zero.

4.6.2 Sugeno Based FIS

Sugeno-type systems are used to model any inference system in which output membership functions are either linear or constant. This fuzzy inference system was

introduced in 1985. It is also called as Takagi-Sugeno-Kang. Sugeno output membership functions (z) are either linear or constant. A typical rule in a Sugeno fuzzy model is:

If Input 1 = x and Input 2 = y , then Output is $z = ax + by + c$.

For a zero-order Sugeno model, the output level z is a constant ($a=b=0$).

Both sugeno and mamdani FIS can be used to perform the similar tasks. Rule base and fuzzification remain same for the variables. There are various defuzzifiers that can be chosen for a mamdani FIS. These defuzzifiers also originate similar results in a sugeno FIS. There is a certain overlap between both types of systems. Mamdani FIS is more widely used. It is used for decision support applications, because of its intuitive and interpretable nature. Consequences of the rules in a sugeno FIS do not have a direct semantic mean. This means that they are not linguistic terms. Also, this interpretability is partially lost. Sugeno FIS rules consequents can have many parameters per rule as per input values. Thus, sugeno FIS gets translated into more degrees of freedom in its design as compared to mamdani FIS. Thus it provides more flexibility. Many parameters can be used in the consequents of the rules of a sugeno FIS. A zero order sugeno FIS can reasonably approximate a mamdani FIS. In computational terms, a sugeno FIS is more efficient than a mamdani FIS. It is so because, sugeno FIS does not involve computationally expensive defuzzification process. Also, a sugeno FIS always generates continuous surfaces. The continuity of the output surface is quite important. Any existence of discontinuities will result in similar inputs originating substantially different outputs. It will be a situation which is undesirable from the control monitoring perspective. Because of continuous structure of output functions, a sugeno FIS is also better and adequate for functional analysis than a mamdani FIS.

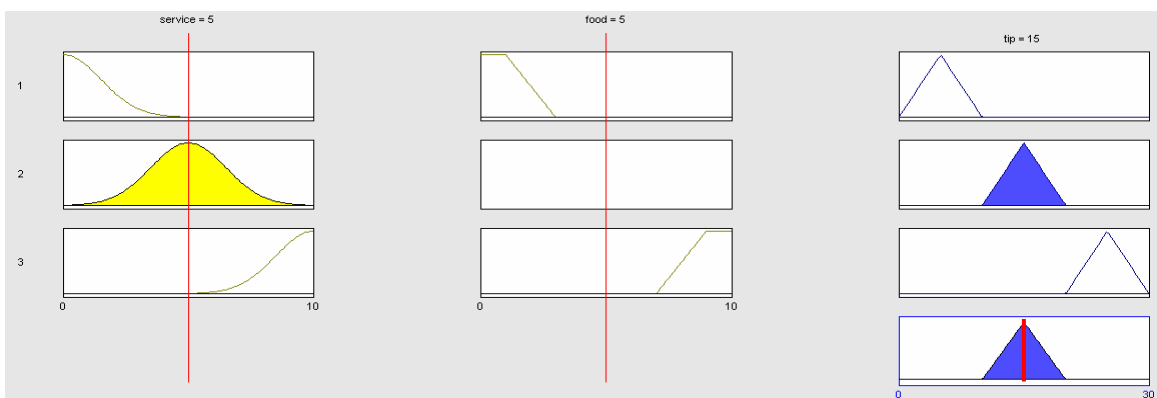

Figure 4.3: Fuzzy Rule Base in the case of a Mamdani Fuzzy Inference System

The above figure 4.3 shows the rule viewer of the fuzzy logic system in case of mamdani inference system. The rule viewer shows one calculation at a time and in great detail.

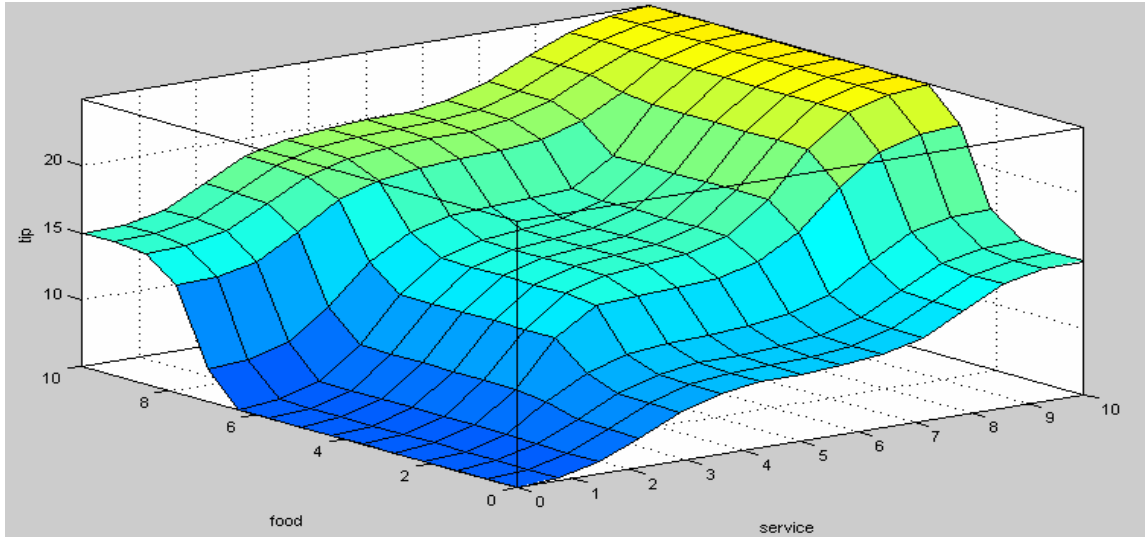

Figure 4.4: Surface View in the case of a Mamdani Fuzzy Inference System

The above figure 4.4 shows the surface view of the fuzzy logic system in case of mamdani inference system. It is very helpful in case of two or more inputs and one output.

4.7 Defuzzification

Defuzzification converts the fuzzy outputs back to crisp values. There are different defuzzification methods given as:

- Max Membership $\mu_c(z^*) \geq \mu_c(z)$ for all $z \in Z$ (10)

- Centroid
$$z^* = \frac{\int \mu_c(z) \cdot z dz}{\int \mu_c(z) dz}$$
 (11)

- Weighted average
$$z^* = \frac{\sum \mu_c(z) \cdot z}{\sum \mu_c(z)}$$
 (12)

- Mean-Max
$$z^* = \frac{a+b}{2}$$
 (13)

- Center of Sum

$$z^* = \frac{\int z^* \sum_{k=1}^n \mu_c(z) dz}{\int \sum_{k=1}^n \mu_c(z) dz} \quad (14)$$

- Center of Largest Area

$$z^* = \frac{\int \mu_c(z) z dz}{\int \mu_c(z) dz} \quad (15)$$

4.8 Fuzzy Control: Scheme

This section describes the classical control scheme and fuzzy control scheme. In classical control scheme we have open loop and closed loop control architecture. Figure 4.5 shows the classical feedback control structure of a plant. In fuzzy control scheme the conventional controller is replaced by fuzzy logic controller. The fuzzy control scheme is shown in figure 4.5.

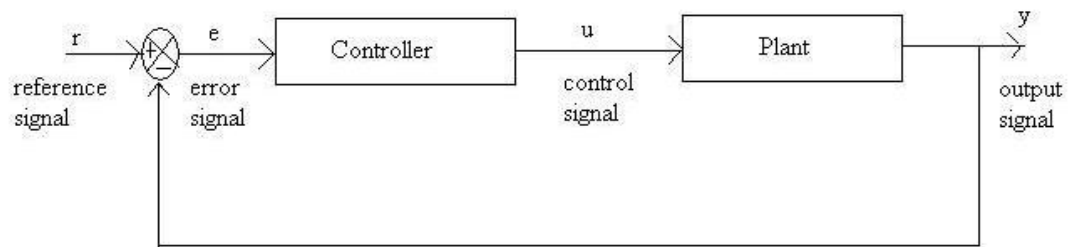

Figure 4.5: Classical Feedback Control Scheme

The majority of fuzzy logic control systems are knowledge-based systems in that either their fuzzy models or their fuzzy logic controllers are described by fuzzy IF-THEN rules, which have to be established based on experts' knowledge about the systems, controllers, performance, etc. Moreover, the introduction of input-output intervals and membership functions is more or less subjective, depending on the designer's experience and the available information. However, we emphasize once again that after the determination of the fuzzy sets, all mathematics to follow are rigorous. Also, the purpose of designing and applying fuzzy logic control systems is, above all, to tackle those vague, ill-described, and complex plants and processes that can hardly be handled by classical systems theory, classical control techniques, and classical two-valued logic. This is the first type of fuzzy logic control system: the fuzzy logic controller directly performs the control actions and thus completely replaces a conventional control algorithm. Yet, there

is another type of fuzzy logic control system: the fuzzy logic controller is involved in a conventional control system and thus becomes part of the mixed control algorithm, so far as to enhance or improve the performance of the overall control system.

The fuzzy logic controller provides an algorithm, which converts the expert knowledge into an automatic control strategy. Fuzzy logic is capable of handling approximate information in a systematic way and therefore it is suited for controlling non linear systems and is used for modelling complex systems, where an inexact model exists or systems where ambiguity or vagueness is common. The fuzzy control systems are rule-based systems in which a set of fuzzy rules represent a control decision mechanism for adjusting the effects of certain system stimuli. With an effective rule base, the fuzzy control systems can replace a skilled human operator. The rule base reflects the human expert knowledge, expressed as linguistic variables, while the membership functions represent expert interpretation of those variables.

Designing a good fuzzy rule base is the key to obtain satisfactory control performance for a particular operation. Classical analysis and control strategy are incorporated in the rule base. The control literature has worked towards reducing the size of the rule base and optimizing the rule base using different optimization techniques like GA, PSO for intelligent controller. At last defuzzified output is obtained from the fuzzy inputs.

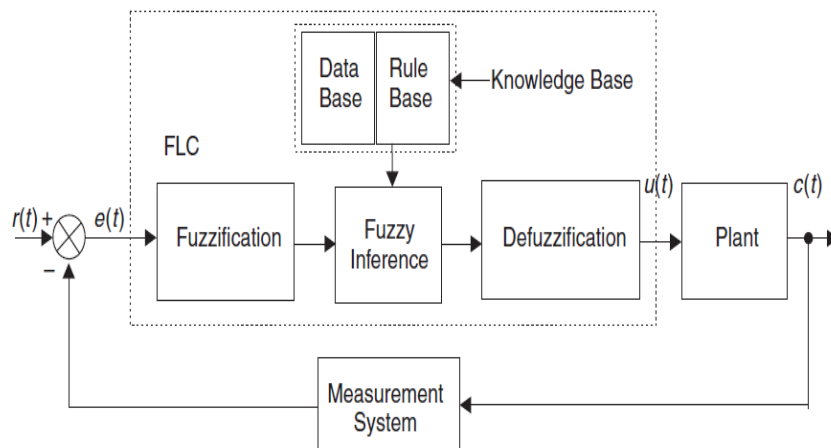

Figure 4.6: Fuzzy Logic Control Scheme

4.9 Fuzzy Logic: Applications

In the decade after Dr. Zadeh's seminal paper on fuzzy sets many theoretical developments in fuzzy logic took place in the United States, Europe, and Japan. From the mid-Seventies to the present, however, Japanese researchers have been a primary force in advancing the practical implementation of the theory; they have done an excellent job of commercializing this technology. Fuzzy logic affects many disciplines. In videography, for instance, Fisher, Sanyo, and others make fuzzy logic camcorders, which offer fuzzy focusing and image stabilization. Mitsubishi manufactures a fuzzy air conditioner that controls temperature changes according to human comfort indexes. Matsushita builds a fuzzy washing machine that combines smart sensors with fuzzy logic. The sensors detect the color and kind of clothes present and the quantity of grit, and a fuzzy microprocessor selects the most appropriate combination from 600 available combinations for water temperature, detergent amount and washes and spins cycle times. The Japanese City of Sendai has a 16-station subway system that is controlled by a fuzzy computer. The ride is so smooth that the riders do not need to hold straps, and the controller makes 70 percent fewer judgmental errors in acceleration and braking than human operators do. Nissan introduced a fuzzy automatic transmission and a fuzzy anti-skid braking system in one of their recent luxury cars. Tokyo's stock market has stock-trading portfolios based on fuzzy logic that outperformed the Nikkei Exchange average. In Japan, there are fuzzy golf diagnostic systems, fuzzy toasters, fuzzy rice cookers, fuzzy vacuum cleaners, and many other industrial fuzzy control processes.

With increasing complexities in system engineering, the focus of fuzzy control is moving from elementary control problems to higher levels in the system hierarchy such as supervisory control, monitoring and diagnosis, and logistic support. It is to be noted that telecommunications, which is one of the major future industries, has started investigating fuzzy control for communication systems and that several pilot projects have been initiated for tackling routing and overload handling problems. So far, the majority of existing applications are purely software-based. However, general purpose fuzzy logic processors or coprocessors will be found to be useful in extremely time critical applications like pattern recognition task in a complex plant automation and in mass produced automotive electronics. The first generation of fuzzy control in the

existing applications exploits only a very small fragment of fuzzy logic theory. In many cases of more complex, ill-structured problems, this first generation technology is not sufficiently equipped to represent and implement the knowledge needed for powerful solutions. Besides, there is strong need for a more systematic design and analysis methodology for fuzzy control applications, spanning the whole life-cycle from perception to all the way up to deployment and maintenance. It must provide answers to make a proper choice of alternative design issues after a thorough analysis of the problem, and must be able to associate variations of parameters to system-performance. At this stage, one should not expect a universal design and optimization strategy for fuzzy control, which will be of some practical use. Such a universal theory does not exist for conventional control engineering either. Instead, we have to proceed from the few isolated islands where we already know exactly how to design a fuzzy control algorithm to clusters of problems and related design methodologies. From the above discussions it is apparent that fuzzy control has tremendous scope in the knowledge based systems approach to closed loop control system, which may be defined as:

A knowledge based system for closed loop control is a system which enhances the performance, reliability and robustness of control by incorporating knowledge which can not be captured in the analytical model used for controller design and that is taken care of by manual modes of operation or by other safety and ancillary logic mechanism.

Summary

This chapter discusses the basics of fuzzy logic, why it is used and how it can be used. There are two types of fuzzy inference system, mamdani based fuzzy inference system and sugeno based fuzzy inference system. In mamdani based fuzzy inference system, inputs and outputs have an If-Then rules and in sugeno based fuzzy inference system, output membership functions are either linear or constant. For defuzzification, there can be different defuzzification methods. Using the knowledge of fuzzy logic, fuzzy logic controller can be designed.

Chapter 5

Problem Formulation

5.1 Process Description

A boiler drum is a vessel where water is converted to steam by the application of heat. For proper boiler control there must always be sufficient water present in the drum to produce steam and prevent damage to the drum and at the same time the water level must not be too high a condition that would prevent the formation of steam in the drum. As the demand for steam increases, the feedwater flow rate into the drum must also increase to maintain the water level within acceptable limits. The boiler system consists of a combustion chamber where combustion of fuel takes place. The burning gases pass around a group of vertical tubes. These tubes called risers carry a mixture of water and steam. At the top of the risers is the drum which is a horizontal cylinder kept about half full of water. The upper part of the drum contains steam. The tubes that leave the bottom of the drum also known as the down comers are insulated from the combustion chamber and carry the water down to a mud drum where mud is separated from the water. Heating the riser tubes with hot flue gas causes the water to circulate and steam to be released in the steam drum. The steam that is produced passes from the drum to the super heaters, which are also located in the combustion chamber. The superheated product steam is then sent to the process where the energy is removed. After preheating, the liquid condensate is returned to the drum where it begins the cycle again.

The steam drum level is derived from the following equation:

$$h = DP + H(\gamma_r - \gamma_s) + (\gamma_w - \gamma_s) \quad (16)$$

where:

h = True drum level – Inches

DP = Measured DP head – Inches

H = Distance between taps – Inches

γ_s = Steam Specific Gravity (S.G.)

γ_r = Reference leg (S.G.)

γ_w = Drum Water (S.G.)

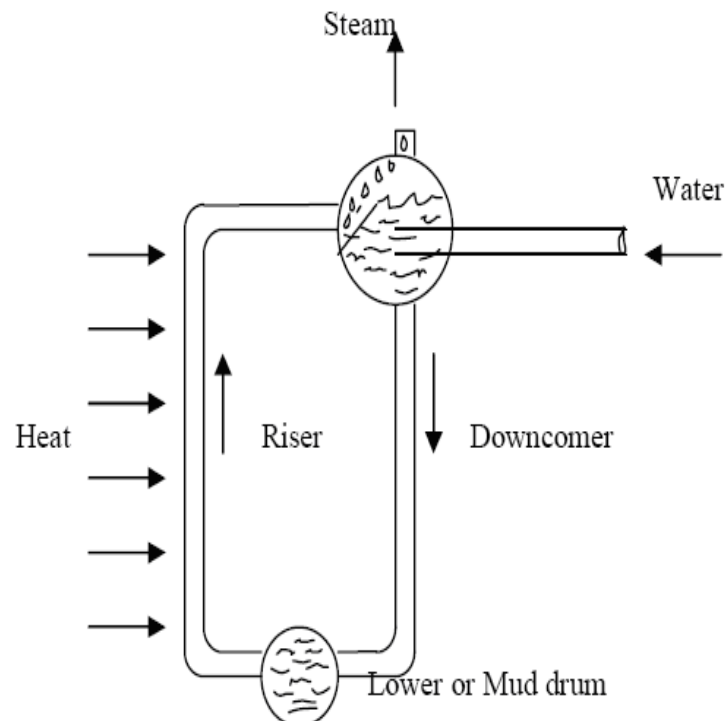

Figure 5.1 Boiler Drum

5.2 Problem Definition

In the process industries, for the proper functioning of boiler we use to control the three elements as steam out flow, level of fluid, and feed water flow. We cannot control pressure, we cannot control temperature, we cannot control level, the only thing we can control is flow.

A boiler system is an integral component of a thermal power plant, and control of the water level in the drum of the boiler system is a critical operational consideration. For the drum level control, a 3-element proportional-integral-derivative (PID) control is a popular conventional approach. This scheme works satisfactorily in the absence of any process disturbances. However, when there are significant process

disturbances, the 3-element PID control scheme does not perform well because of lack of knowledge of proper controller gains to cope with such disturbances. Inevitably over time and use, PID controllers get detuned. Hence, there is good motivation to investigate alternatives to this control scheme.

5.3 Shrink/Swell Effect

Dynamic shrink/swell is a phenomenon that produces variations in the level of the liquid surface in the steam drum whenever boiler load occur. This behavior is strongly influenced by the actual arrangement of steam generating tubes in the boiler. During operation, the tubes exposed to the radiant heat from the flame are always producing steam. As the steam rises in the tubes, boiler water is also carried upward and discharged into the steam drum. Tubes that are not producing significant steam flow have a net downward flow of boiler water from the steam drum to the mud drum.

The tubes producing large quantities of steam are termed risers and those principally carrying water down to the mud drum from the steam drum are termed downcomers. Excluding the tubes subject to radiant heat input from the firebox flame, a given tube will serve as a riser at some firing rates and a downcomer at other firing rates.

The mechanics of the natural convection circulation of boiler water within the steam generator is the origin of the dynamic shrink/swell phenomenon. A sudden steam load increase will naturally produce a drop in the pressure in the steam drum, because, initially at least, the firing rate cannot increase fast enough to match the steam production rate at the new demand level. When the pressure in the drum drops, it has a dramatic effect on the natural convection within the boiler. The drop in pressure causes a small fraction of the saturated water in the boiler to immediately vaporize, producing a large amount of boil-up from most of the tubes in the boiler. During the transient, most of the tubes temporarily become risers. The result is that the level in the steam drum above the combustion chamber rises. This rise in level is actually an inverse response to the load change. Since, the net steam draw rate has gone up, the net flow of water to the boiler needs to increase, because the total mass of water in the boiler is falling. However, the level controller senses a rise in the level of the steam drum and calls for a reduction in the flow of feed-water to the boiler. This inverse response to a sudden load increase is

dynamic swell. Dynamic shrink is also observed when a sudden load decrease occurs. However, the dynamic shrink phenomenon does not disrupt the natural convection circulation of the boiler as completely as the dynamic swell effect. Consequently, the reduction in level produced by a sudden decrease in load is typically much smaller and of shorter duration than the effect produced by dynamic swell.

5.4 Fuzzy Logic Controller: Design

PID controller is a standard control structure for classical control theory. But the performance is greatly distorted and the efficiency is reduced due to nonlinearity in the process plant. The fuzzy PID controllers are the natural extension of their conventional version, which preserve their linear structure of PID controller. The fuzzy PID controllers are designed using fuzzy logic control principle in order to obtain a new controller that possesses analytical formulas very similar to digital PID controllers. Fuzzy PID controllers have variable control gains in their linear structure. These variable gains are nonlinear function of the errors and changing rates of error signals. The main contribution of these variable gains in improving the control performance is that they are self-tuned gains and can adapt to rapid changes of the errors and rate of change of error caused by time delay effects, nonlinearities and uncertainties of the underlying process.

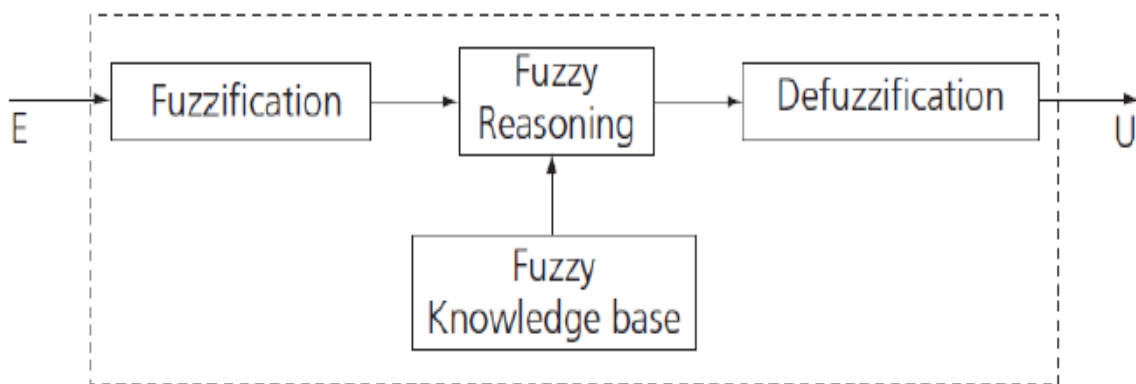

Figure 5.2: Architecture of Fuzzy Control

E is the input and U is the output. E input is first fuzzified using fuzzifier and then using knowledge base and rule base, output is derived and then defuzzification is done using defuzzifier.

Table 5.1: Linguistic Variable of Fuzzy Logic Control

Error $e(t)$		Change in error $\Delta e(t)$		Controller output $u(t)$	
NB	Negative Big	NB	Negative Big	NB	Negative Big
NM	Negative Medium	NM	Negative Medium	NM	Negative Medium
NS	Negative Small	NS	Negative Small	NS	Negative Small
ZO	Zero	ZO	Zero	ZO	Zero
PS	Positive Small	PS	Positive Small	PS	Positive Small
PM	Positive Medium	PM	Positive Medium	PM	Positive Medium
PB	Positive Big	PB	Positive Big	PB	Positive Big

The above table 5.1 shows the linguistic variables for error, change in error and controller output. There are seven linguistic variables for error, change in error and controller output.

Table 5.2: IF-THEN Rule Base for Fuzzy Logic Control

$u(t)$	$e(t)$							
		NB	NM	NS	ZO	PS	PM	PB
$\Delta e(t)$	NB	NB	NB	NB	NB	NM	NS	ZO
	NM	NB	NB	NB	NM	NS	ZO	PS
	NS	NB	NB	NM	NS	NS	PS	PS
	ZO	NB	NM	NS	ZO	ZO	PM	PM
	PS	NM	NS	ZO	PS	PS	PB	PB
	PM	NS	ZO	PS	PM	PM	PB	PB
	PB	ZO	PS	PM	PB	PB	PB	PB

The above table 5.2 shows the rule base of the fuzzy logic controller. Mamdani inference system is used for developing rule base of the fuzzy logic controller. There are total forty nine rules in this rule base. NB means negative big, NM means negative medium, NS means negative small, ZO means zero, PS means positive small, PM means positive medium and PB means positive big. The rules are shown in the above table as IF $e(t)$ is NB and $\Delta e(t)$ is PS THEN $u(t)$ is NM.

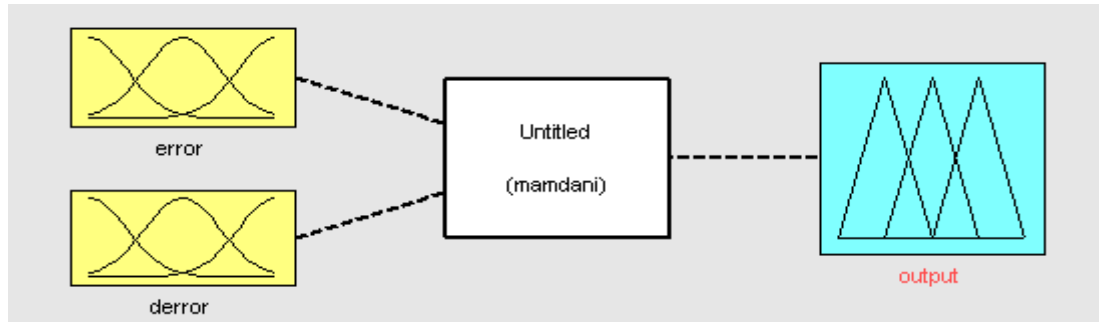

Figure 5.3: Mamdani Fuzzy Inference System Developed for Fuzzy Controller

The above figure 5.3 shows the fuzzy inference system, in which there are two inputs as error and change in error and one output.

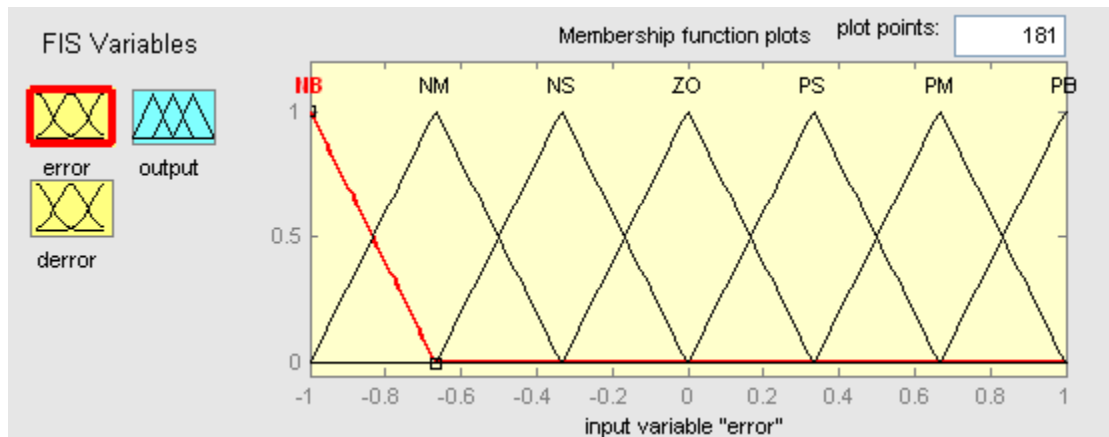

Figure 5.4: Membership function for Input 1

The above figure 5.4 shows the membership function plots for the first input variable. Triangular membership function is taken for the input 1.

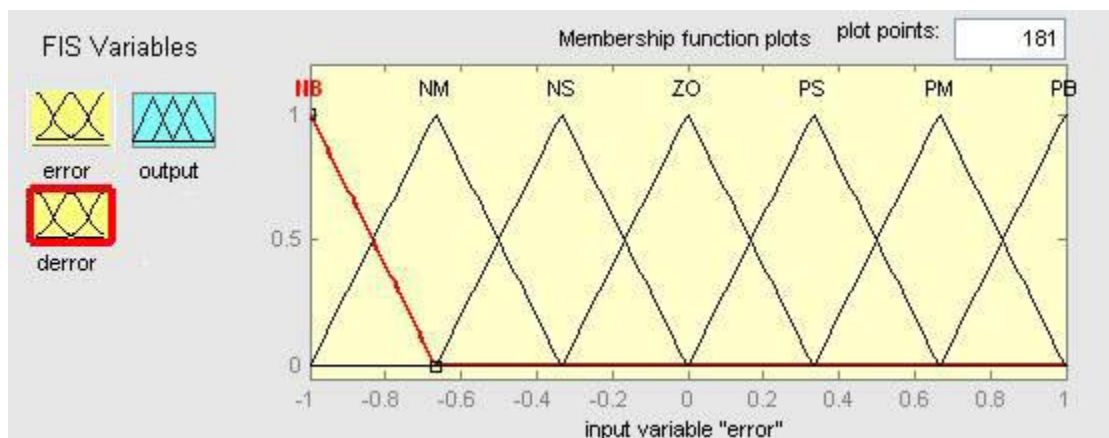

Figure 5.5: Membership function for Input 2

The above figure 5.5 shows the membership function plots for the second input variable. Triangular membership function is taken for the input 2.

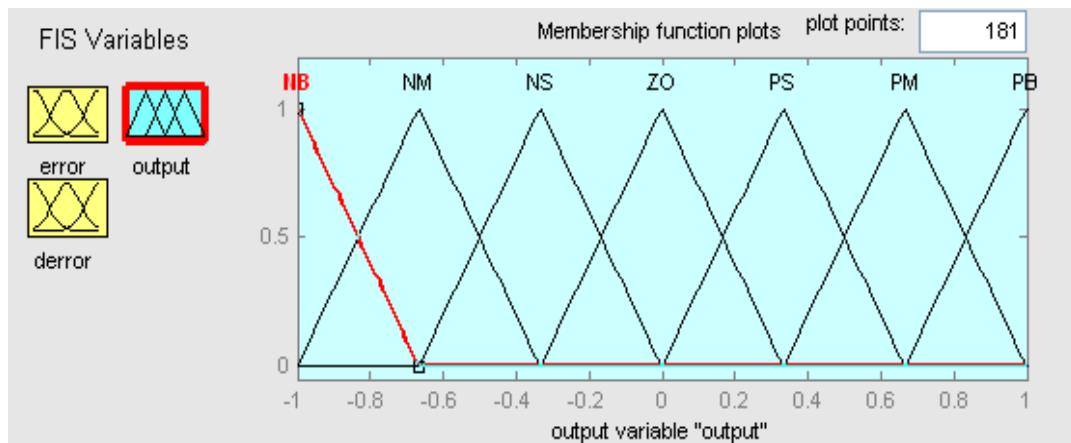

Figure 5.6: Membership function for Output

The above figure 5.6 shows the membership function plots for the output variable. Triangular membership function is taken for the output.

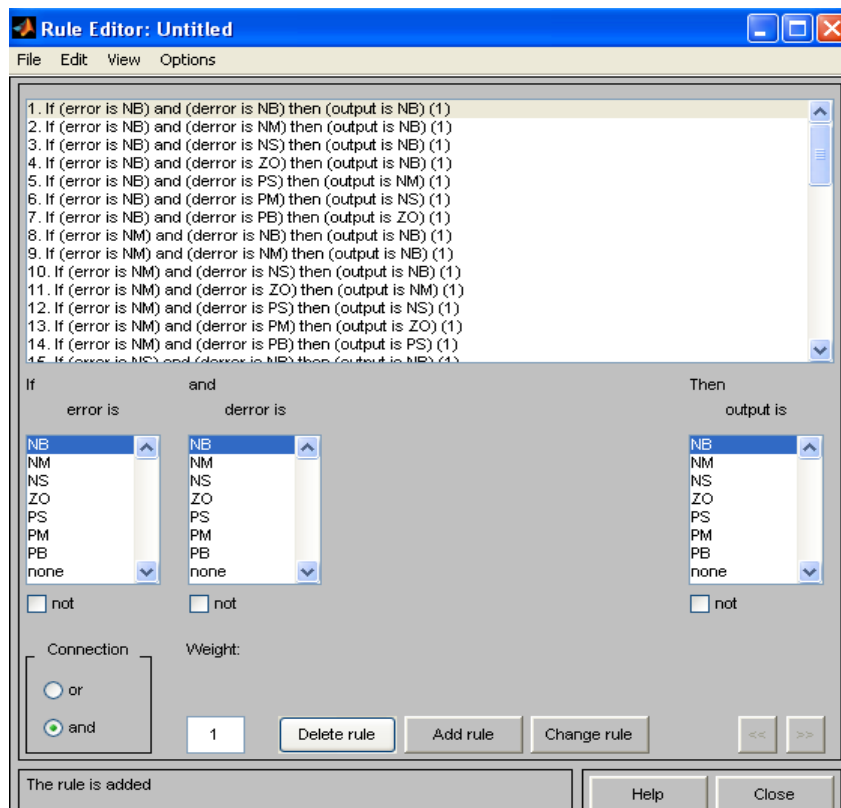

Figure 5.7: Rule Base

The above figure 5.7 shows the rule base of the fuzzy logic controller. It consists of 49 rule base using If-and-then rule condition.

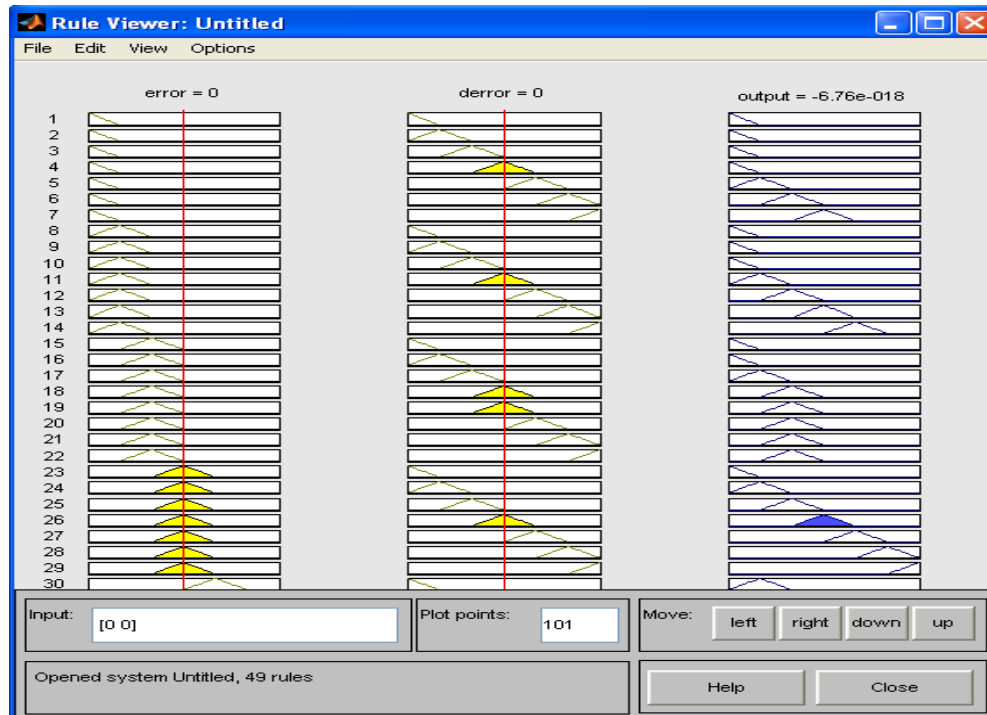

Figure 5.8: Rule Viewer for Fuzzy Inference System

The above figure 5.8 shows the rule viewer for the fuzzy inference system. The rule viewer shows one calculation at a time and in great detail. If the entire output surface of system is to be viewed, that is, the entire span of the output set based on the entire span of the input set, the surface viewer is required.

Summary

This chapter discusses the basics and the significance of boiler steam drum. The level of boiler steam drum is very critical and is required to be kept at its set point. There can be shrink and swell effect in boiler steam drum which can cause disturbance in the level. Hence a controller is required to control the steam drum level. Fuzzy PID controller and fractional PID controller can be used for this purpose.

Chapter 6

Results and Discussions

The process transfer function for steam drum

$$G_p(s) = \frac{-0.25s + 0.25}{2s^2 + s} \quad (17)$$

Valve transfer function

$$G_v(s) = \frac{1}{0.5s + 1} \quad (18)$$

6.1 1-Element Steam Drum Level Control without Load Disturbance

In 1-element steam drum level control, a conventional PID controller is used. The tuning method used here for conventional PID controller is Ziegler Nichols tuning method. The PID controller parameters found out are:

Proportional gain (K_p) = 1.26

Integral gain (K_i) = 0.003

Derivative gain (K_d) = 2.23

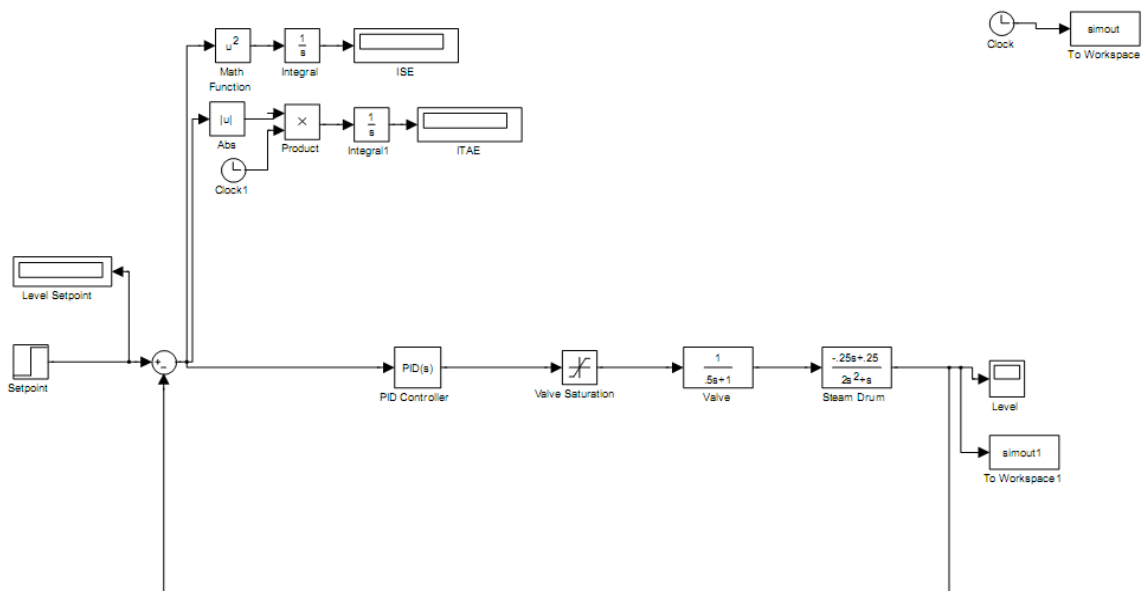

Figure 6.1: 1-Element Steam Drum Level Control using PID Controller without Load Disturbance

The above figure 6.1 is the simulink model for the 1-element steam drum level control using conventional PID controller. Here steam load disturbance is not considered. Unit step is considered as input.

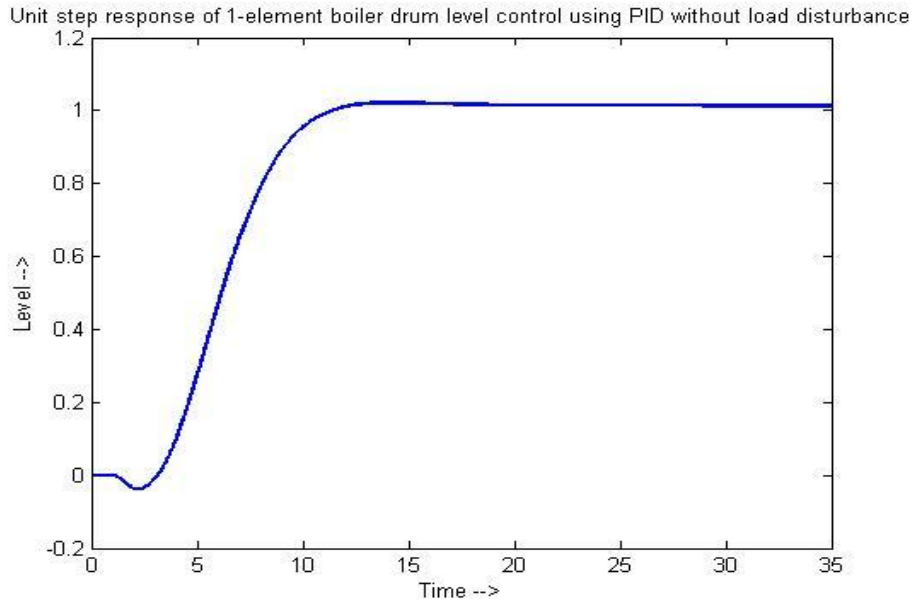

Figure 6.2: Unit Step Response of 1- Element Steam Drum Level Control using PID Controller without Load Disturbance

The above figure 6.2 is the unit step response of the 1-element steam drum level control without steam load disturbance. It has inverse response because of a right hand plane zero in the process transfer function. Using this, settling time and peak overshoot are calculated.

Table 6.1: Different Parameters

Serial No.	Settling time(t_s)	Peak Overshoot (M_p)	Integral Square Error(ISE)	Integral Time Absolute Error(ITAE)
1	9.7396	1.5549	4.397	29.44

In the above table 6.1, different control parameters are shown. Settling time, peak overshoot, integral square error and integral time absolute error are calculated.

6.2 1-Element Steam Drum Level Control with Load Disturbance

In a drum boiler, steam demand can vary. Hence there is disturbance parameter in the 1-element steam drum control. Transfer function considered for steam load disturbance:

$$G_d(s) = \frac{-0.25s + 0.25}{2s^2 + s} \quad (19)$$

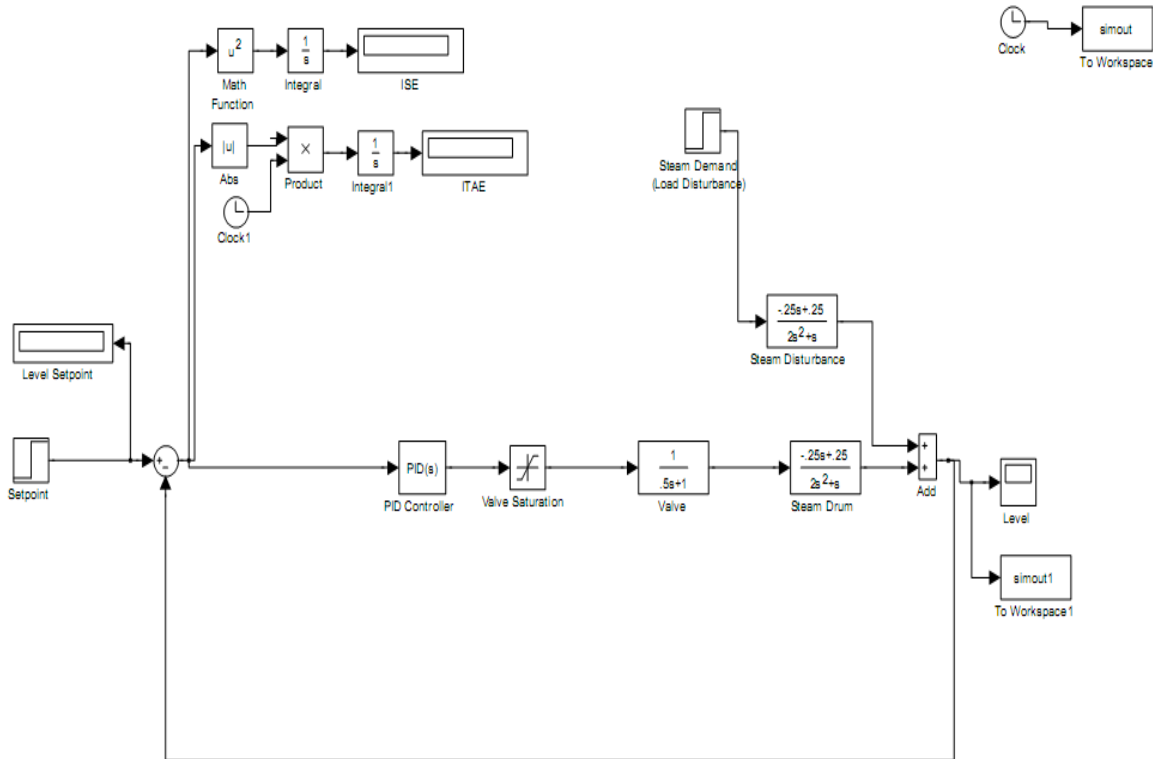

Figure 6.3: 1-Element Steam Drum Level Control using PID Controller with Load Disturbance

The above figure 6.3 is the simulink model for the 1-element steam drum level control using conventional PID controller. Unit step is taken as input. Here load disturbance is considered and unit step is also considered as disturbance. Second order transfer function is taken for steam load disturbance. Unity feedback is used in this simulink model. Valve saturation is considered here, as steam drum level is to be controlled and level of a steam drum is to be maintained between upper level of the drum and lower level of the drum. ISE and ITAE are calculated in this simulink model.

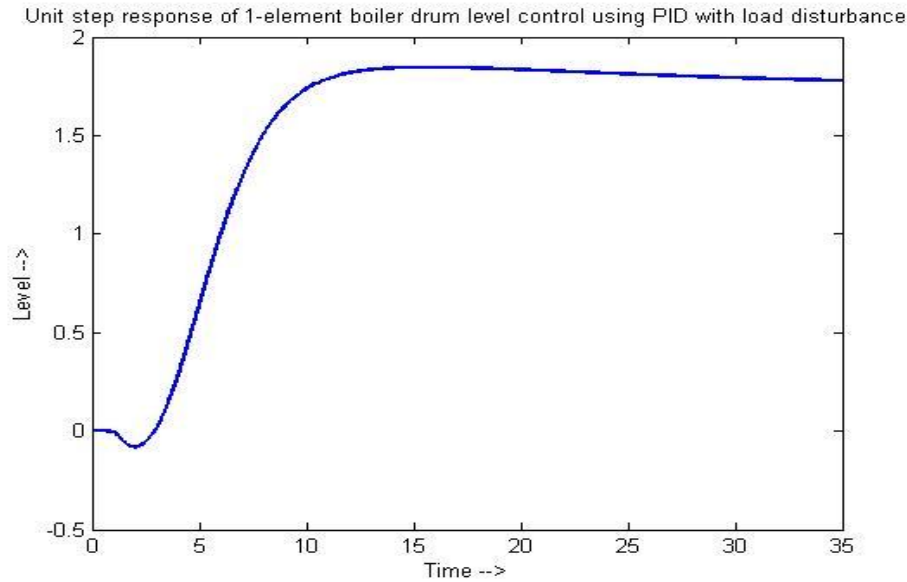

Figure 6.4: Unit Step Response of 1- Element Steam Drum Level Control using PID Controller with Load Disturbance

The above figure 6.4 is the unit step response of the 1-element steam drum level control with steam load disturbance. It can be seen from the above graph that after considering load disturbance, step response is deteriorated.

Table 6.2: Different Parameters

Serial No.	Settling time(t_s)	Peak Overshoot (M_p)	Integral Square Error(ISE)	Integral Time Absolute Error(ITAE)
1	35.000	87.5022	22.36	512.9

In the above table 6.2, different control parameters are shown. From the table, it can be seen that settling time, peak overshoot, integral square error and integral time absolute error have increased after the steam load disturbance is applied. Hence a controller is required to improve the step response.

In the next section, 2-element steam drum level control without feedwater flow disturbance is introduced.

6.3 2-Element Steam Drum Level Control without Feedwater Flow Disturbance

To Control the effect of steam load disturbance, feedforward controller is used. Combination of feedback controller along with feedforward controller is used for the 2-element drum level control.

Transfer function of feedforward controller ($G_{ff}(s) = -G_d(s)/G(s)$)

$$G(s) = G_p(s).G_v(s) \quad (20)$$

$$G_{ff}(s) = \frac{-0.5s - 1}{s + 1} \quad (21)$$

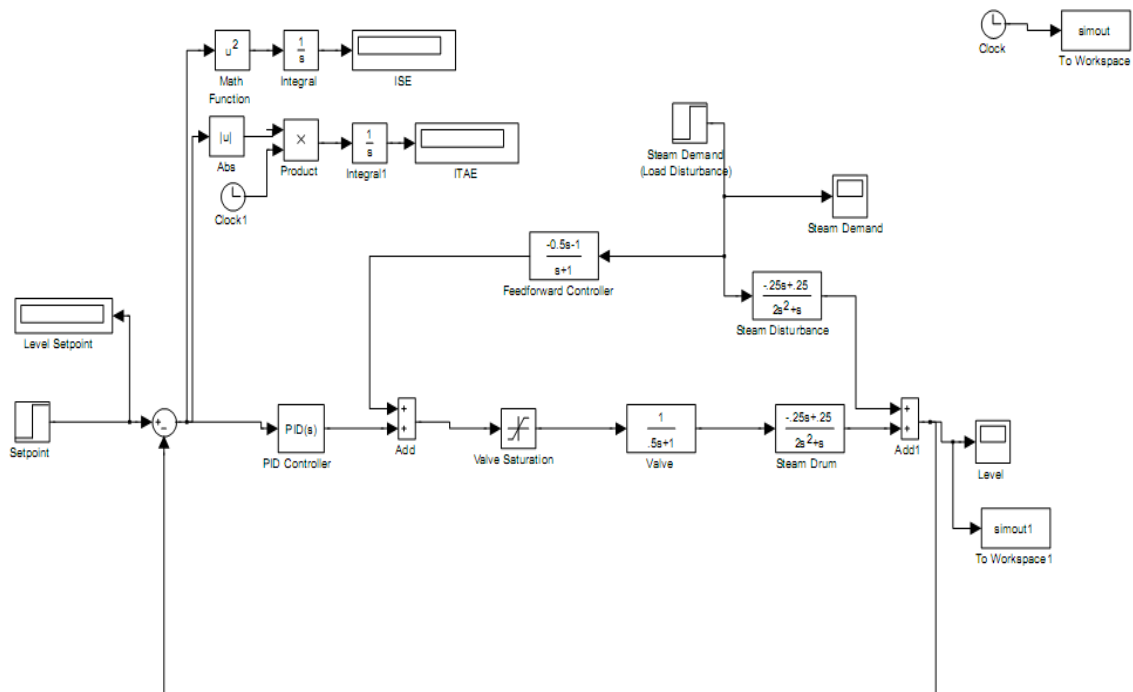

Figure 6.5: 2-Element Steam Drum Level Control using PID Controller without Feedwater Flow Disturbance

The above figure 6.5 is the simulink model for the 2-element steam drum level control using conventional PID controller. Here feedwater flow disturbance is not considered. Unit step is taken as input. Unity feedback is used in this simulink model. Valve saturation is considered here, as steam drum level is to be controlled and level of a steam drum is to be maintained between upper level of the drum and lower level of the drum. ISE and ITAE are calculated in this simulink model.

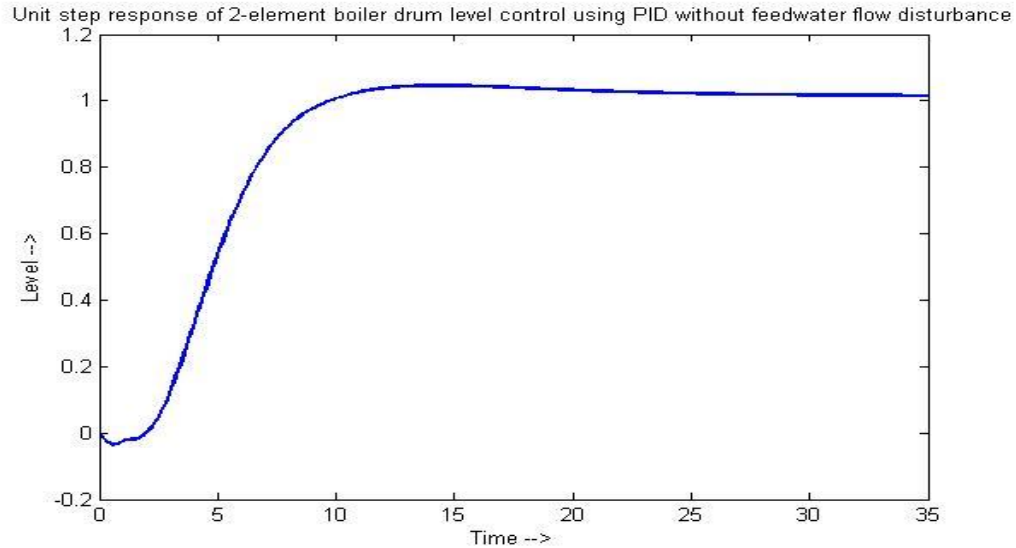

Figure 6.6: Unit Step Response of 2- Element Steam Drum Level Control using PID Controller without Feedwater Flow Disturbance

The above figure 6.6, unit step is taken as input. It is the response of the 2-element steam drum level control without feedwater flow disturbance. Using this settling time and peak overshoot are calculated.

Table 6.3: Different Parameters

Serial No.	Settling time(t_s)	Peak Overshoot (M_p)	Integral Square Error(ISE)	Integral Time Absolute Error(ITAE)
1	8.3920	4.5851	3.088	27.96

In the above table 6.3, different control parameters are shown. Settling time, peak overshoot, integral square error and integral time absolute error are calculated

From the above response and table, it is shown that after applying feedback controller and feedforward controller, step response is improved. Settling time, peak overshoot, integral square error and integral time absolute error are also reduced.

In the next section, 2-element steam drum level control with feedwater flow disturbance is introduced.

6.4 2-Element Steam Drum Level Control with Feedwater Flow Disturbance

There can be variation in feedwater flow which can cause variation in level of steam drum. Transfer function of feedwater flow disturbance:

$$G_{d1}(s) = \frac{1}{s} \quad (22)$$

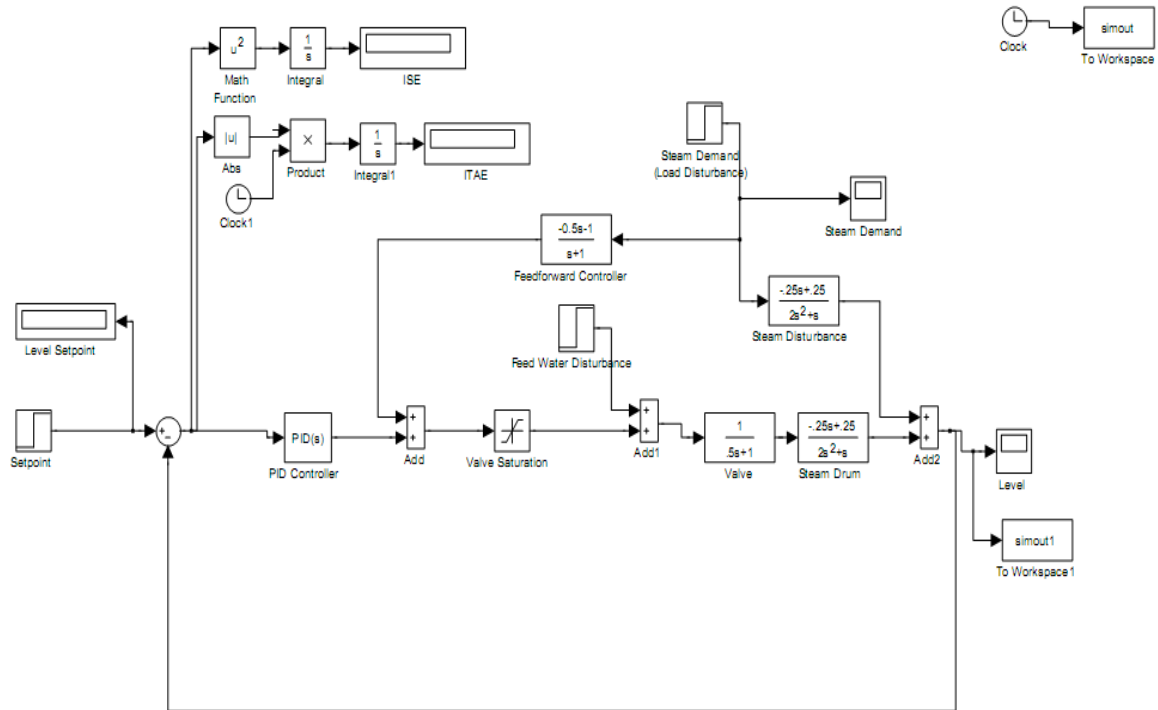

Figure 6.7: 2-Element Steam Drum Level Control using PID Controller with Feedwater Flow Disturbance

The above figure 6.7 is the simulink model of the 2-element steam drum level control with feedwater flow disturbance. It can be seen from the above figure that feedwater flow disturbance is considered which can vary the steam drum level. Unit step is taken as input. Unity feedback is used in this simulink model. Here feedwater flow disturbance is considered and unit step is taken as disturbance. Valve saturation is considered here, as steam drum level is to be controlled and level of a steam drum is to be maintained between upper level of the drum and lower level of the drum. ISE and ITAE are calculated in this simulink model.

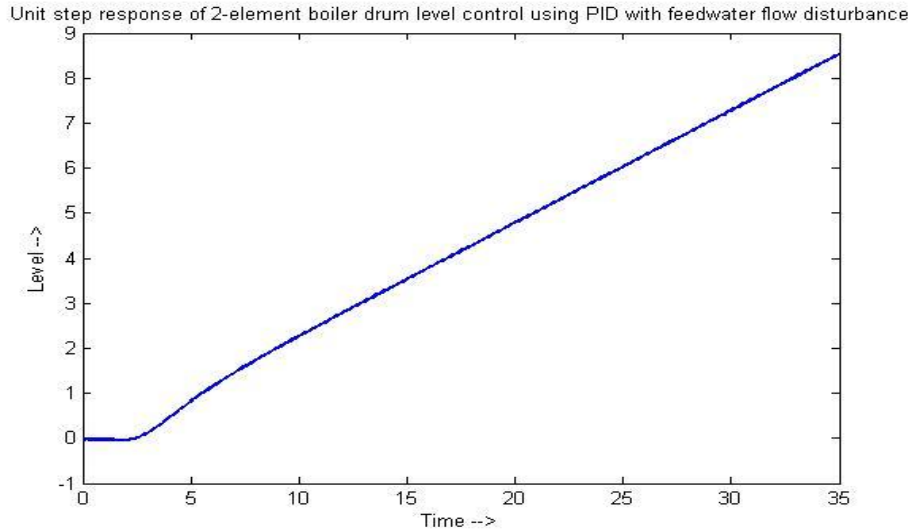

Figure 6.8: Unit Step Response of 2- Element Steam Drum Level Control using PID Controller with Feedwater Flow Disturbance

The above figure 6.8 is the unit step response of the 2-element steam drum level control with feedwater flow disturbance. It can be seen from the above graph that after considering feedwater flow disturbance, step response is deteriorated.

Table 6.4: Different Parameters

Serial No.	Settling time(t_s)	Peak Overshoot (M_p)	Integral Square Error(ISE)	Integral Time Absolute Error(ITAE)
1	35.000	752.9666	517.5	-2836

In the above table 6.4, different control parameters are shown. From the above table, it can be seen that settling time, peak overshoot, integral square error and integral time absolute error are increased. Hence a controller is required to improve the step response.

6.5 3-Element Steam Drum Level Control using Conventional PID Controller

In 3- element boiler drum level control, cascade controller and feedforward controller are used. Here conventional PID controller is used as primary controller and PI

controller is used as secondary controller. Tuning of primary controller is done using Ziegler Nichols tuning method and tuning of secondary controller is done using auto tuning function in simulink. The secondary controller parameters found out using auto tuning are:

$$\text{Proportional gain (K}_{p2}) = 1.42$$

$$\text{Integral gain (K}_{i2}) = 4.04$$

Transfer function of steam load disturbance:

$$G_D(s) = \frac{0.25s - 0.25}{2s^2 + s} \quad (23)$$

Transfer function of feedforward controller = $G_{ff1}(s)$

Transfer function of secondary loop:

$$G_s(s) = \frac{1.2s + 4.04}{0.5s^2 + 2.2s + 4.04} \quad (24)$$

Transfer function of steam drum:

$$G_p(s) = \frac{-0.25s + 0.25}{2s^2 + s} \quad (25)$$

$G_{\text{Primary}} = (\text{Transfer function of secondary loop}) \times (\text{Transfer function of steam drum})$

$$\begin{aligned} G_{ff1}(s) &= G_{\text{Primary}}(s)/G_D(s) \\ &= \frac{0.5s^2 + 2.2s + 4.04}{1.2s + 4.04} \end{aligned} \quad (26)$$

This transfer function is not proper, as the number of zeros is more than the number of poles. Hence a pole is added to make it proper transfer function. Let pole at $s=-1$ is added.

$$\begin{aligned} G_{ff1}(s) &= \left(\frac{0.5s^2 + 2.2s + 4.04}{1.2s + 4.04} \right) \left(\frac{1}{s+1} \right) \\ &= \frac{0.5s^2 + 2.2s + 4.04}{1.2s^2 + 5.24s + 4.04} \end{aligned} \quad (27)$$

The primary controller parameters found out using Ziegler Nichols tuning method are:

$$\text{Proportional gain (K}_{p1}) = 0.92$$

$$\text{Integral gain (K}_{i1}) = 0.002$$

$$\text{Derivative gain (K}_{d1}) = 0.92$$

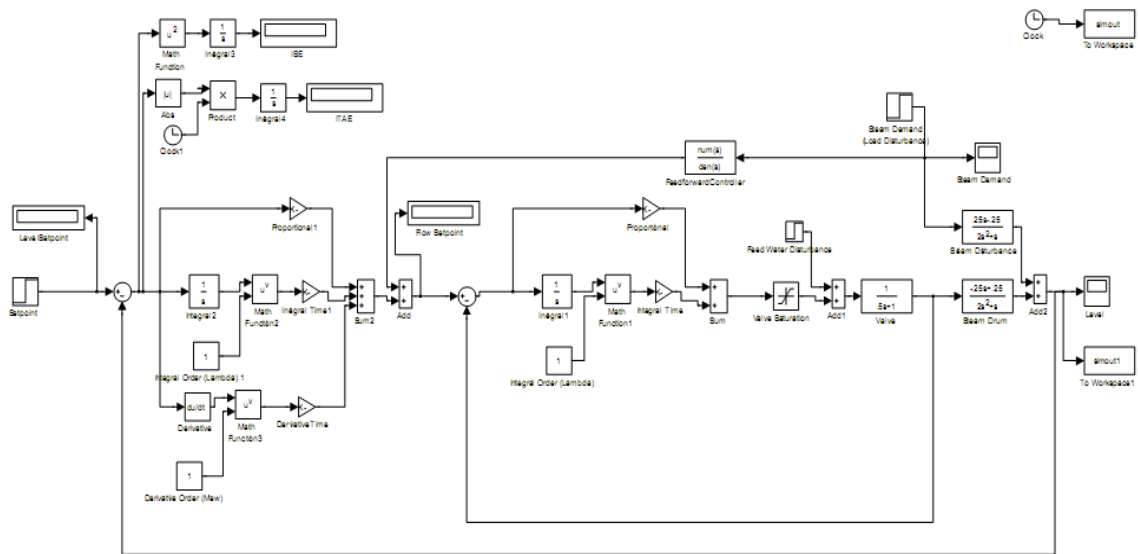

Figure 6.9: 3-Element Steam Drum Level Control with Conventional PID as Primary Controller

The above figure 6.9 is the simulink model of 3-element steam drum level control with conventional PID as primary controller and PI controller as secondary controller.

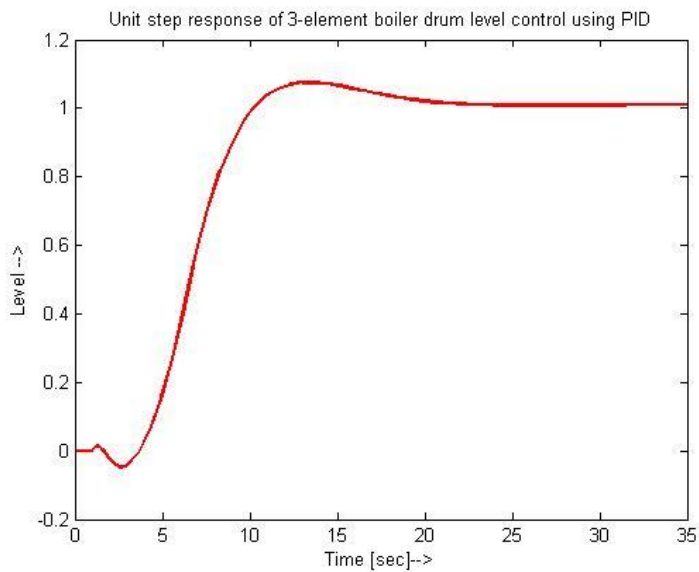

Figure 6.10: Unit Step Response of 3-Element Boiler Drum Level Control using Conventional PID

It can be seen from the above figure 6.10 that the step response is improved by using 3- element control.

Table 6.5: Different Parameters

Serial No.	Different values of λ (integral order)and μ (derivative order)	Settling time(t_s)	Peak Overshoot (M_p)	Integral Square Error(ISE)	Integral Time Absolute Error(ITAE)
1	$\lambda=1, \mu=1$	16.4879	7.5127	4.929	34.8

In the above table 6.5, different control parameters are shown. From the above table, it can be seen that settling time, peak overshoot, integral square error and integral time absolute error have decreased using 3- element drum level control.

6.6 3-Element Steam Drum Level Control using Fuzzy PID Controller

Fuzzy PID controller is used as primary controller. Fuzzy controller is used to find the optimum values of K_p , K_i and K_d . These parameters are given to PID controller that produces the control signal which is used a set point for the secondary controller.

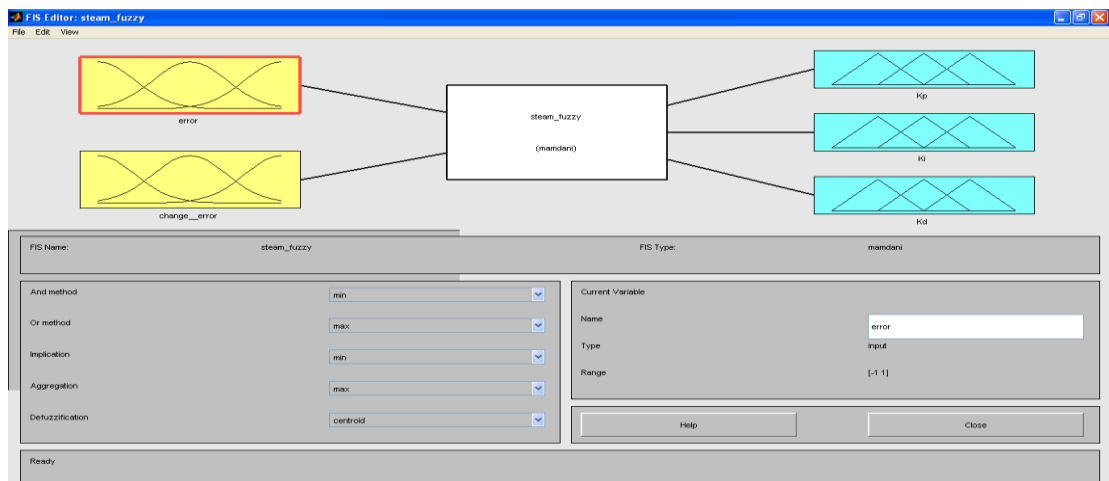

Figure 6.11: Mamdani Fuzzy Inference System Developed for Fuzzy Controller

The above figure 6.11 shows the fuzzy inference system, in which there are two inputs as error and change in error and three outputs as proportional gain, integral gain and derivative gain.

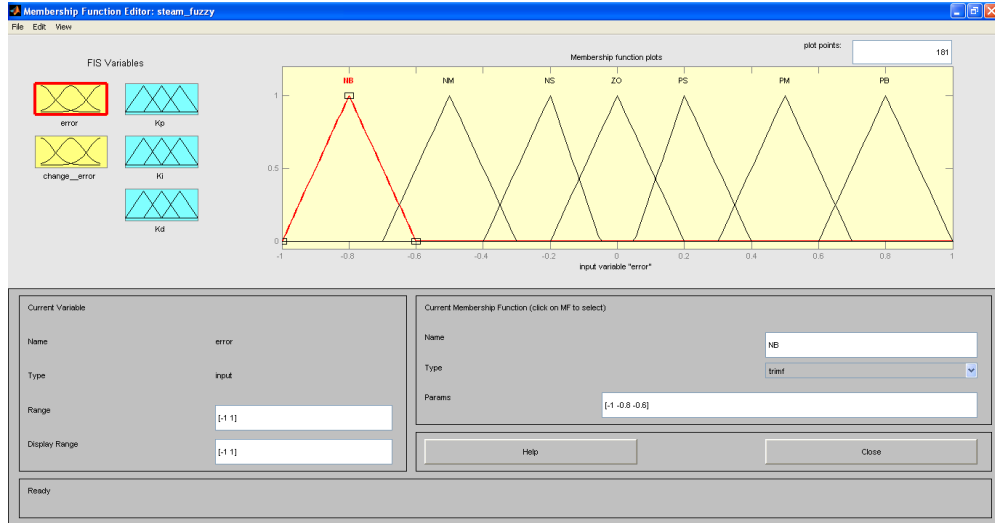

Figure 6.12: Membership Function for Input 1

The above figure 6.12 shows the membership function plots for the first input variable. Triangular membership function is taken for both inputs and outputs. Specify the range then assign the variable name. Then take the second input variable. Again membership functions are assigned with range. Range is taken from -1 to 1.

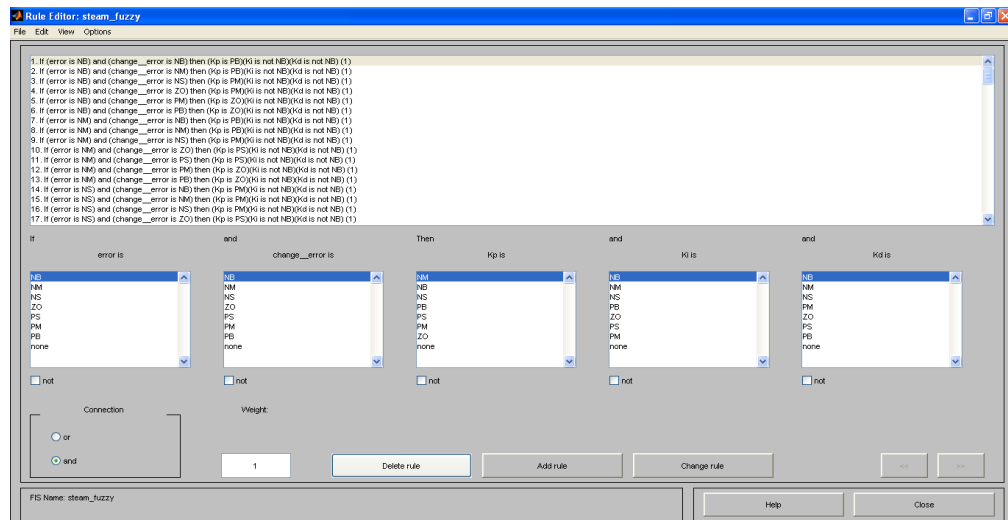

Figure 6.13: Rule Base

The above figure 6.13 shows the rule base of the fuzzy logic controller for the three element control system. It consists of 147 rule based using If-and-then rules condition.

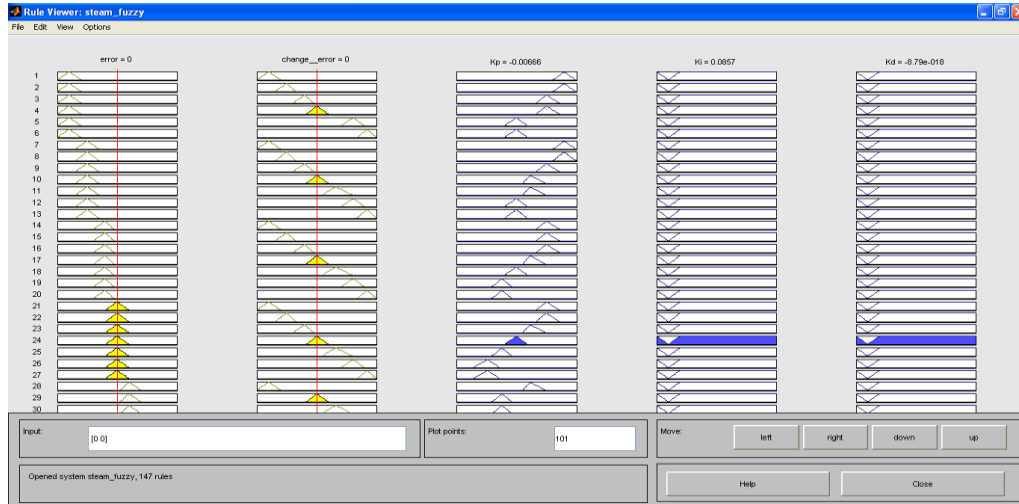

Figure 6.14: Rule Viewer for Fuzzy Inference System

The above figure 6.14 shows the rule viewer for the fuzzy inference system. The rule viewer shows one calculation at a time and in great detail.

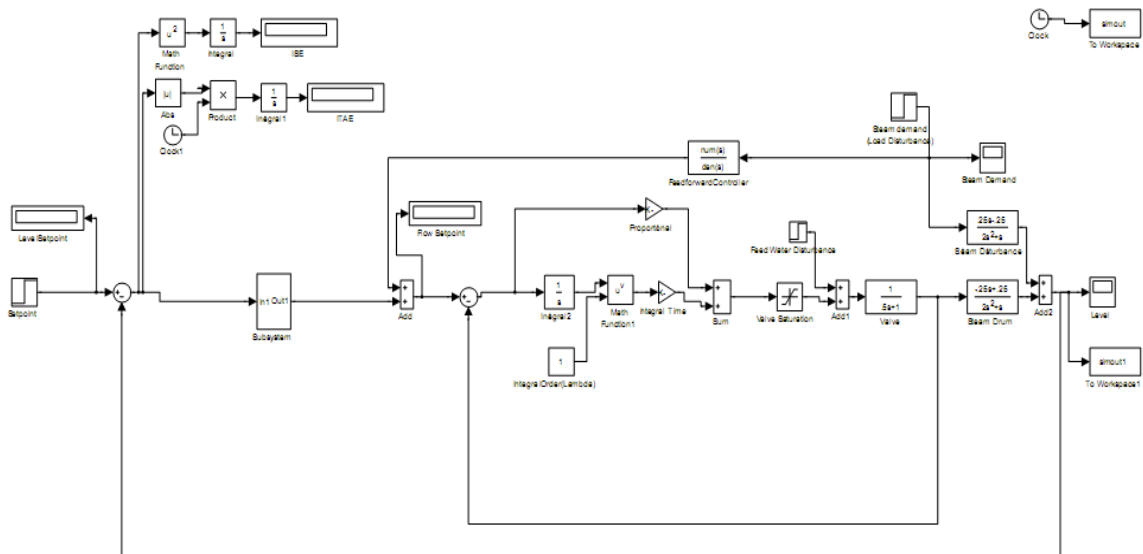

Figure 6.15: 3-Element Steam Drum Boiler with Fuzzy PID as Primary Controller

The above figure 6.15 is the simulink block of 3-element steam drum level control. Fuzzy PID controller is used as primary controller and PI controller is used as secondary controller.

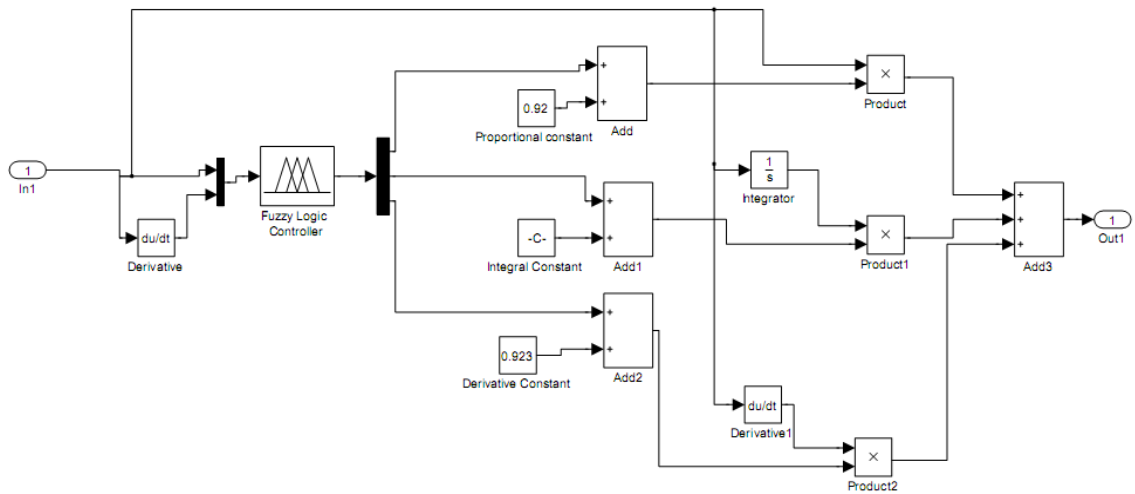

Figure 6.16: Fuzzy PID Controller

The above figure 6.16 is the subsystem block which is the fuzzy PID controller. It takes the error signal as input and the control signal as output.

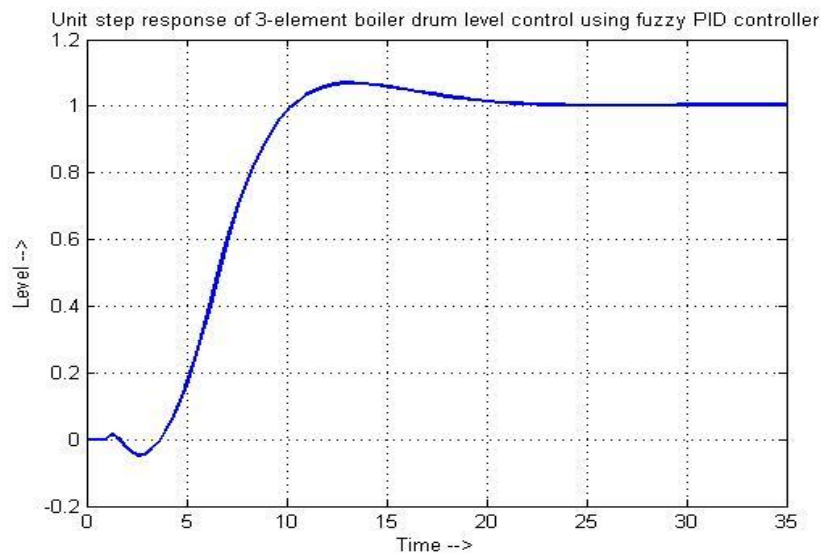

Figure 6.17: Unit Step Response of 3-Element Steam Drum Level Control using Fuzzy PID as Primary Controller

Table 6.6: Different Parameters

Serial No.	Settling time(t_s)	Peak Overshoot (M_p)	Integral Square Error(ISE)	Integral Time Absolute Error(ITAE)
1	15.8592	6.9412	4.923	31.65

From the above graph 6.17 and table 6.6, it is seen that the settling time, peak overshoot, integral square error and integral time absolute error using fuzzy PID controller as primary controller are reduced as compared to using conventional PID controller as primary controller. Hence fuzzy PID controller gives better response than conventional PID controller.

6.7 3-Element Steam Drum Level Control using Fractional PID Controller

Fractional PID controller is used as primary controller. For different values of λ and μ , output response is taken. λ is the integral order and μ is the derivative order. Transfer function of fractional order PID.

$$G_{FOPID}(s) = \frac{u(s)}{e(s)} = K_c \left(1 + \frac{1}{\tau_i s^\lambda} + \tau_d s^\mu \right) \tag{28}$$

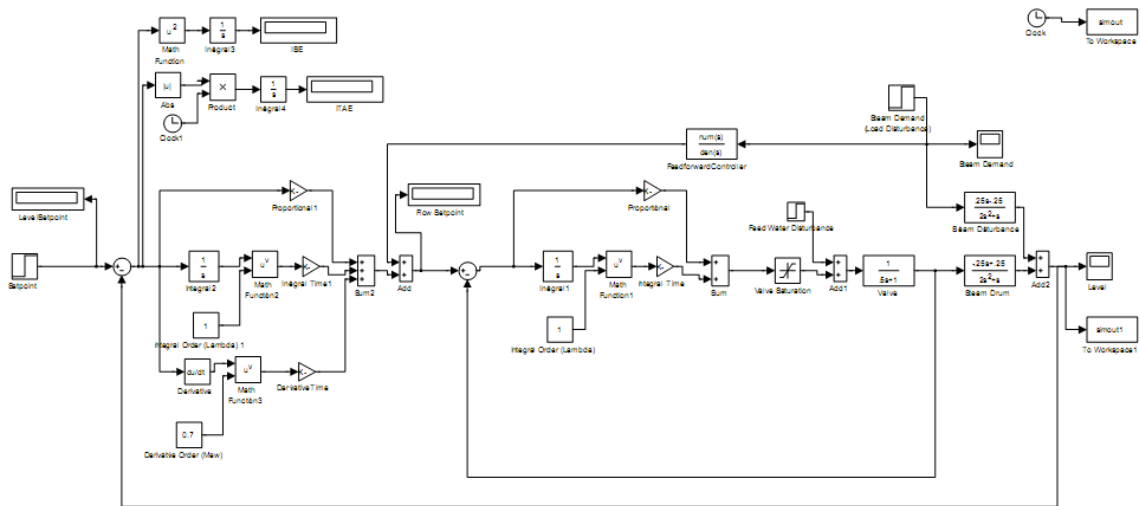

Figure 6.18: 3-Element Steam Drum Boiler with Fractional PID Controller as Primary Controller

The above figure 6.18 is the simulink block of 3- element steam drum level control using fractional PID controller as primary controller. In a fractional PID controller, for different values of integral order (λ) and derivative order (μ), different unit step responses come out. In the next section, different combinations of integral order and derivative order are taken and unit step responses and different control parameters are calculated.

6.7.1 With $\lambda=1$ and varying values of $\mu<1$

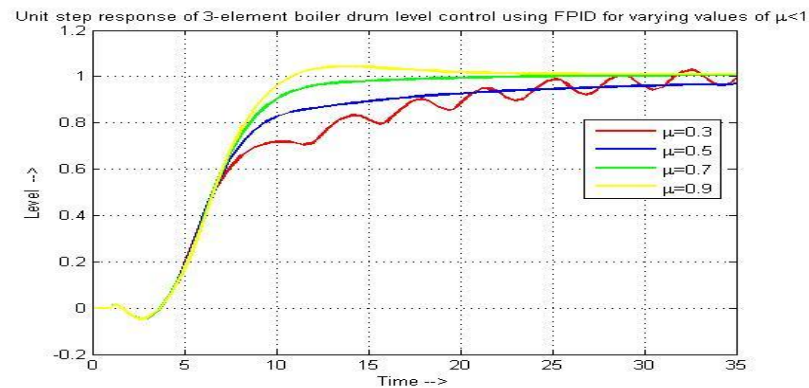

Figure 6.19: Unit Step Response of 3-Element Boiler Drum Level Control using FPID for Different Values of $\mu<1$

The above figure 6.19 shows the unit step response of the 3-element steam drum level control using fractional order PID controller for $\lambda=1$ and $\mu<1$.

Table 6.7: Comparison of Parameters for Different Combinations of λ and μ

Serial No.	Different values of λ (integral order)and μ (derivative order)	Settling time(t_s)	Peak Overshoot (M_p)	Integral Square Error(ISE)	Integral Time Absolute Error(ITAE)
1	$\lambda=1, \mu=0.3$	30.4526	2.9106	5.518	71.36
2	$\lambda=1, \mu=0.5$	26.1217	-3.0075	5.144	60.84

3	$\lambda=1, \mu=0.7$	10.9670	0.7136	4.941	29.68
4	$\lambda=1, \mu=0.9$	9.5904	4.4332	4.92	33.39

It can be seen from the above table 6.7 that with the increase in the value of μ , control parameters are improved.

6.7.2 With varying values of $\lambda < 1$ and $\mu = 1$

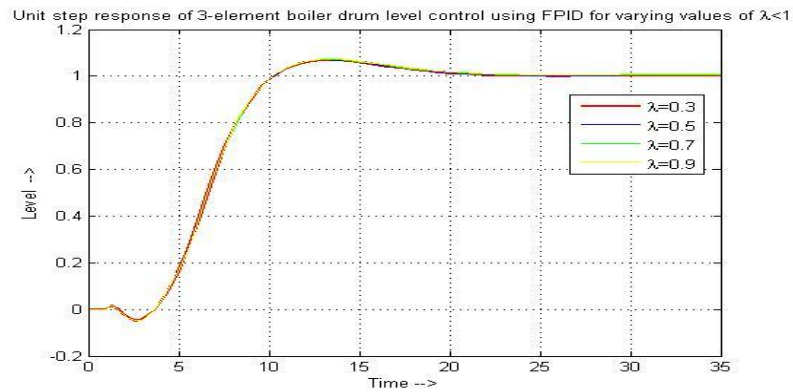

Figure 6.20: Unit Step Response of 3-Element Boiler Drum Level Control using FPID for Different Values of $\lambda < 1$

The above figure 6.20 shows the unit step response of the 3-element steam drum level control using fractional order PID controller for $\lambda < 1$ and $\mu = 1$.

Table 6.8: Comparison of Parameters for Different Combinations of λ and μ

Serial No.	Different values of λ (integral order) and μ (derivative order)	Settling time (t_s)	Peak Overshoot (M_p)	Integral Square Error (ISE)	Integral Time Absolute Error (ITAE)
1	$\lambda=0.3, \mu=1$	15.1631	6.8382	4.921	30.87
2	$\lambda=0.5, \mu=1$	15.8254	6.9584	4.923	31.59
3	$\lambda=0.7, \mu=1$	15.8294	7.1290	4.924	32.57

4	$\lambda=0.9, \mu=1$	15.8294	7.3619	4.927	33.93
---	----------------------	---------	--------	-------	-------

It can be seen from the above table 6.8 that with the increase in the value of λ , control parameters are almost remained constant.

6.7.3 With varying values of $\lambda < 1$ and $\mu < 1$

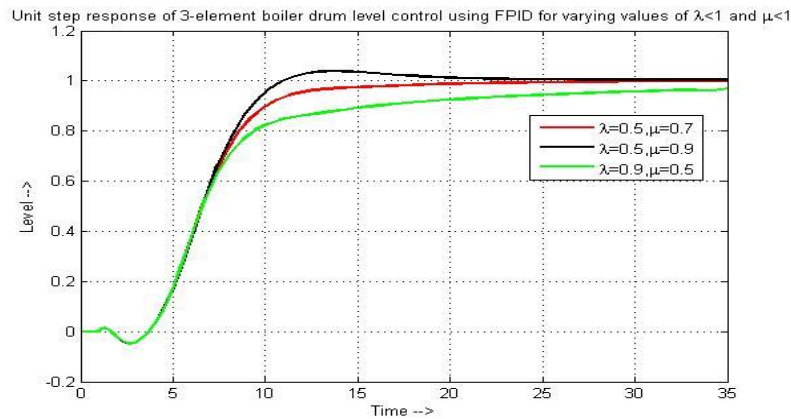

Figure 6.21: Unit Step Response of 3-Element Boiler Drum Level Control using FPID for Different Values of $\lambda < 1$ and $\mu < 1$

The above figure 6.21 shows the unit step response of the 3-element steam drum level control using fractional order PID controller for $\lambda < 1$ and $\mu < 1$.

Table 6.9: Comparison of Parameters for Different Combinations of λ and μ

Serial No.	Different values of λ (integral order) and μ (derivative order)	Settling time(t_s)	Peak Overshoot (M_p)	Integral Square Error(ISE)	Integral Time Absolute Error(ITAE)
1	$\lambda=0.5, \mu=0.5$	28.8998	-3.2496	5.17	64.91
2	$\lambda=0.5, \mu=0.7$	11.2745	0.0101	4.946	30.5
3	$\lambda=0.5, \mu=0.9$	9.4956	3.8472	4.916	30.07
4	$\lambda=0.7, \mu=0.5$	27.5060	-3.2137	5.162	63.73

5	$\lambda=0.9, \mu=0.5$	26.8160	-3.0846	5.151	61.99
6	$\lambda=0.7, \mu=0.7$	11.3471	0.2210	4.944	29.77
7	$\lambda=0.9, \mu=0.9$	9.5604	4.2765	4.919	32.49

It can be seen from the above table 6.9 that from all the different combinations of λ and μ , control parameters for the values of $\lambda=0.5$ and $\mu=0.9$ are less than other values of λ and μ .

6.7.4 With $\lambda=1$ and varying values of $\mu>1$

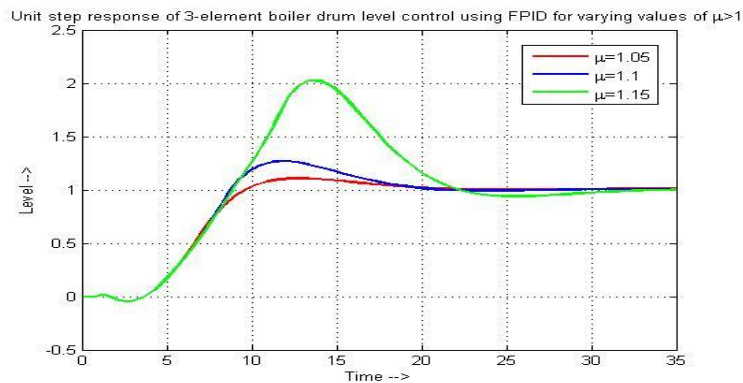

Figure 6.22: Unit Step Response of 3-Element Boiler Drum Level Control using FPID for Different Values of $\mu>1$

The above figure 6.22 shows the unit step response of the 3-element steam drum level control using fractional order PID controller for $\lambda=1$ and $\mu>1$.

Table 6.10: Comparison of Parameters for Different Combinations of λ and μ

Serial No.	Different values of λ (integral order)and μ (derivative order)	Settling time(t_s)	Peak Overshoot (M_p)	Integral Square Error(ISE)	Integral Time Absolute Error(ITAE)
1	$\lambda=1, \mu=1.05$	17.2634	10.8457	4.95	36.21

2	$\lambda=1, \mu=1.1$	18.2568	26.9155	5.253	47.29
3	$\lambda=1, \mu=1.15$	27.1280	102.6134	10.13	133.4

It can be seen from the above table 6.10 that with the increase in the value of μ greater than 1, control parameters increased.

6.7.5 With varying values of $\lambda > 1$ and $\mu = 1$

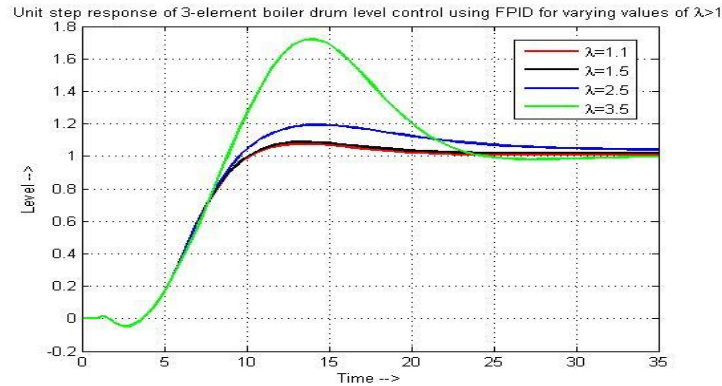

Figure 6.23: Unit Step Response of 3-Element Boiler Drum Level Control using FPID for Different Values of $\lambda > 1$

The above figure 6.23 shows the unit step response of the 3-element steam drum level control using fractional order PID controller for $\lambda > 1$ and $\mu = 1$.

Table 6.11: Comparison of Parameters for Different Combinations of λ and μ

Serial No.	Different values of λ (integral order) and μ (derivative order)	Settling time(t_s)	Peak Overshoot (M_p)	Integral Square Error(ISE)	Integral Time Absolute Error(ITAE)
1	$\lambda=1.1, \mu=1$	16.4708	7.6954	4.931	35.81
2	$\lambda=1.5, \mu=1$	17.8708	8.8964	4.949	41.76
3	$\lambda=2.5, \mu=1$	29.1639	19.4633	5.23	72.31
4	$\lambda=3.5, \mu=1$	22.5083	72.0494	7.983	111.1

It can be seen from the above table 6.11 that with the increase in the value of λ greater than 1, control parameters increased.

6.7.6 With varying values of $\lambda > 1$ and $\mu > 1$

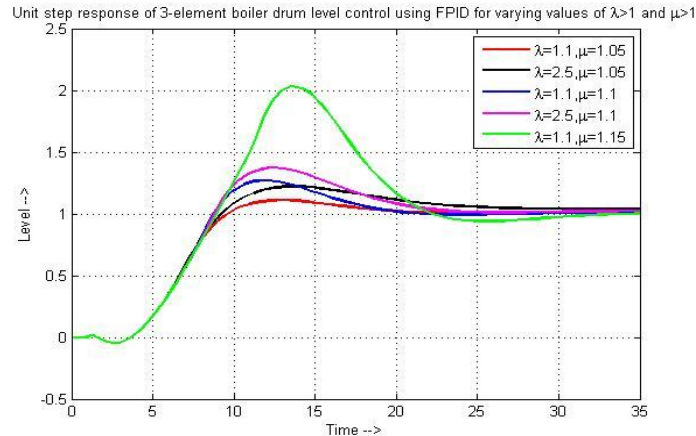

Figure 6.24: Unit Step Response of 3-Element Boiler Drum Level Control using FPID for Different Values of $\lambda > 1$ and $\mu > 1$

The above figure 6.24 shows the unit step response of the 3-element steam drum level control using fractional order PID controller for $\lambda > 1$ and $\mu > 1$.

Table 6.12: Comparison of Parameters for Different Combinations of λ and μ

Serial No.	Different values of λ (integral order)and μ (derivative order)	Settling time(t_s)	Peak Overshoot (M_p)	Integral Square Error(ISE)	Integral Time Absolute Error(ITAE)
1	$\lambda=1.1, \mu=1.05$	17.2528	11.0396	4.953	37.17
2	$\lambda=2.5, \mu=1.05$	25.9464	22.1678	5.27	70.22
3	$\lambda=1.1, \mu=1.1$	18.2539	27.0849	5.259	47.7
4	$\lambda=2.5, \mu=1.1$	20.7319	37.3054	5.71	69.5
5	$\lambda=1.1, \mu=1.15$	27.1344	103.15	10.16	133.8

It can be seen from the above table 6.12 that from all the different combinations of λ and μ , control parameters for the values of $\lambda=1.1$ and $\mu=1.05$ are less than other values of λ and μ .

6.7.7 With varying values of $\lambda > 1$ and $\mu < 1$

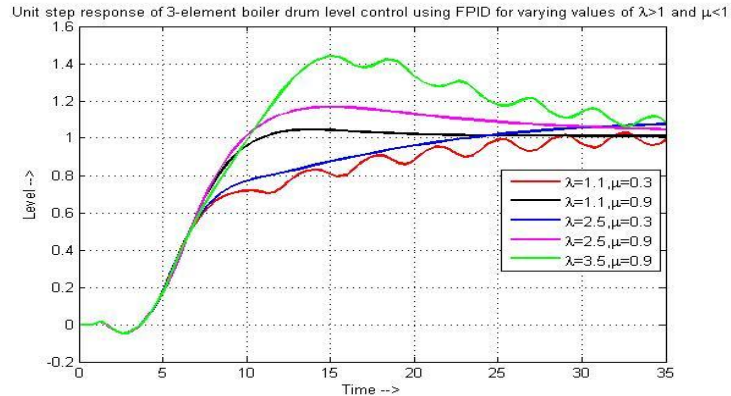

Figure 6.25: Unit Step Response of 3-Element Boiler Drum Level Control using FPID for Different Values of $\lambda > 1$ and $\mu < 1$

The above figure 6.25 shows the unit step response of the 3-element steam drum level control using fractional order PID controller for $\lambda > 1$ and $\mu < 1$.

Table 6.13: Comparison of Parameters for Different Combinations of λ and μ

Serial No.	Different values of λ (integral order)and μ (derivative order)	Settling time(t_s)	Peak Overshoot (M_p)	Integral Square Error(ISE)	Integral Time Absolute Error(ITAE)
1	$\lambda=1.1, \mu=0.3$	30.7228	2.7914	5.501	69.68
2	$\lambda=1.1, \mu=0.9$	9.6321	4.6308	4.922	34.46
3	$\lambda=2.5, \mu=0.3$	35.0000	7.5494	5.26	62.59
4	$\lambda=2.5, \mu=0.9$	33.6524	16.7093	5.20	74.87
5	$\lambda=3.5, \mu=0.3$	35.0000	44.1635	6.77	146.4

It can be seen from the above table 6.13 that from all the different combinations of λ and μ , control parameters for the values of $\lambda=1.1$ and $\mu=0.9$ are less than other values of λ and μ .

6.7.8 With varying values of $\lambda < 1$ and $\mu > 1$

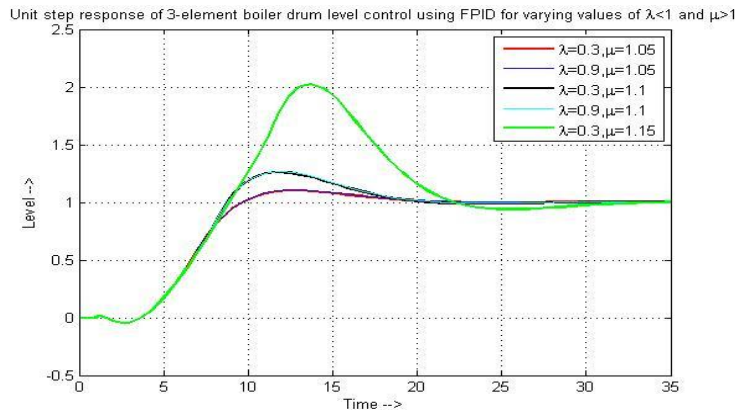

Figure 6.26: Unit Step Response of 3-Element Boiler Drum Level Control using FPID for Different Values of $\lambda < 1$ and $\mu > 1$

The above figure 6.26 shows the unit step response of the 3-element steam drum level control using fractional order PID controller for $\lambda < 1$ and $\mu > 1$.

Table 6.14: Comparison of Parameters for Different Combinations of λ and μ

Serial No.	Different values of λ (integral order)and μ (derivative order)	Settling time(t_s)	Peak Overshoot (M_p)	Integral Square Error(ISE)	Integral Time Absolute Error(ITAE)
1	$\lambda=0.3, \mu=1.05$	16.6063	10.1377	4.94	32.67
2	$\lambda=0.9, \mu=1.05$	16.5726	10.6821	4.95	35.39
3	$\lambda=0.3, \mu=1.1$	18.0217	26.2982	5.23	46.06
4	$\lambda=0.9, \mu=1.1$	18.2628	26.7665	5.25	46.97
5	$\lambda=0.3, \mu=1.15$	27.0965	102.409	10.05	132.3

It can be seen from the above table 6.14 that from all the different combinations of λ and μ , control parameters for the values of $\lambda=0.3$ and $\mu=1.05$ are less than other values of λ and μ .

From the above graphs and tables for different combinations of integral order and derivative order, for $\lambda=0.5$ and $\mu=0.9$, all the parameters are minimum. Hence combination of $\lambda=0.5$ and $\mu=0.9$ is taken for fractional PID controller.

6.8 Comparison of Different Control Techniques

Unit step response of 3- element boiler drum level control is taken using different control techniques:

- Conventional PID controller with $\lambda=1$, $\mu=1$
- Fuzzy PID controller
- Fractional PID controller with $\lambda=0.5$, $\mu=0.9$

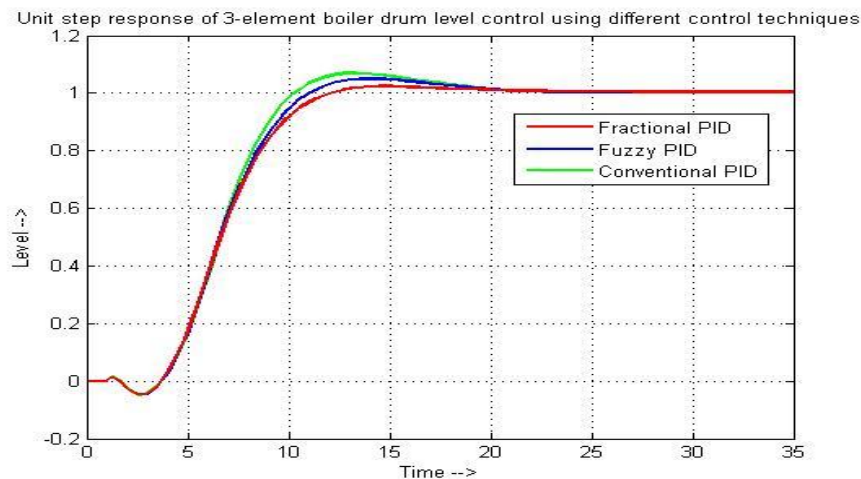

Figure 6.27: Unit Step Response of 3-Element Boiler Drum Level Control using Different Control Techniques

The above figure 6.27 shows the unit step responses of 3-element boiler drum level control using different control techniques for the primary control of cascade controller. Three different controllers used here are conventional PID controller, fuzzy PID controller and fractional PID controller.

Table 6.15: Comparison of Parameters for Different Control Techniques

Serial No.	Control Strategy	Different values of λ (integral order)and μ (derivative order)	Settling time(t_s)	Peak Overshoot (M_p)	Integral Square Error(ISE)	Integral Time Absolute Error(ITAE)
1	Conventional PID Controller	$\lambda=1, \mu=1$	16.4879	7.5127	4.929	34.8
2	Fuzzy PID Controller		15.8592	6.9412	4.923	31.65
3	Fractional PID Controller	$\lambda=0.5, \mu=0.9$	9.4956	3.8472	4.916	30.07

From the graph 6.27 and table 6.15, it is shown that response of fuzzy PID controller is better than conventional PID controller. Further the response of fractional PID controller with $\lambda=0.5$ and $\mu=0.9$ is better than both conventional and fuzzy PID controller.

Summary

This chapter discusses the simulation and the response of various control techniques used for the level control of boiler steam drum. For 3-element steam drum level control, cascade controller and feedforward controller are used. Then the comparison between conventional PID controller, fuzzy PID controller and fractional PID controller used as primary controller of cascade controller is made and it is found out that the fractional PID controller is better than both conventional PID controller and fuzzy PID controller.

Chapter 7

Conclusion and Future Scope

This thesis work discusses a process control case study taking steam drum level control of boiler. First of all a single element steam drum level control of boiler is developed and a conventional PID controller is implemented in it. Then a two element steam drum level control is developed. When disturbances are considered, single element drum level control and two element steam drum level control becomes unstable. Hence a three element steam drum level control is required. In three element drum level control, cascade controller and feedforward controller is used. A comparative study is done using different control techniques for the primary control of cascade controller. First, the conventional PID controller is implemented as primary controller. The PID controller gives a high overshoot and high settling time. So artificial intelligence principles in the controller architecture are proposed and implemented. Then the fuzzy PID controller is implemented and it gives a better response than the conventional PID controller. Then the fractional PID controller is used and unit step responses are shown for different values of integral order and derivative order. It is found out that the fractional PID controller has the better response than both conventional and fuzzy PID controller.

In the future scope, neural network based feedforward controller and genetic algorithm based online optimization techniques can be implemented to improve the control performance. For online tuning of PID controller and fractional PID controller, better tuning method can be used. Genetic algorithm can be used for this purpose.

References

- [1] K. J. Astrom, K. Eklund, "A simplified non-linear model of a drum boiler-turbine unit," *International Journal of Control*, vol. 16, no. 1, pp. 145-169, 1972
- [2] John P. McDonald, Harry G. Kwatny, "Design and analysis of boiler-turbine-generator controls using optimal linear regulator theory," *IEEE Transactions on Automatic Control*, vol. AC-18, no. 3, pp. 202-209, June 1973
- [3] K. B. Lee, "Application of a fuzzy logic based self-tuning PID controller to the control of drum water level of a boiler for a power generating plant," *APSCOM-93, 2nd International Conference on Advances in Power System Control, Operation and Management 1993*, vol. 2, pp 849-854, 1993
- [4] I. Podlubny, "Fractional-order systems and fractional-order controllers," *The Academy of Sciences Institute of Experimental Physics, UEF-03-94, Kosice, Slovak Republic*, 1994
- [5] B J Huang and P Y Ko, "A system dynamics model of fire-tube shell boiler," *Journal of dynamic systems, measurements and control*, vol. 116, pp. 745-754, December 1994
- [6] Hugh F. VanLandingham and Nishith D. Tripathi, "Knowledge-based adaptive fuzzy control of drum level in a boiler system," *Southcon/96, Conference Record*, pp. 454 - 459, Jun 1996
- [7] G. Chen, "Conventional and fuzzy PID controllers: An overview," *International Journal of Intelligent Control and Systems*, vol. 1, pp. 235-246, 1996
- [8] Heidar A. Malki and Guanrong Chen, "A fuzzy logic controller for boiler system in power plants," 1996. *ISCAS '96, Connecting the World*, 1996 *IEEE International Symposium on Circuits and Systems*, vol. 1, pp 652-656, 1996.
- [9] I. Podlubny, "Fractional-order systems and $PI^\lambda D^\mu$ -controllers," *IEEE Transactions on Automatic Control*, vol. 44, pp. 208-214, 1999
- [10] I. Petras, "The fractional order controllers: Methods for their synthesis and application," *Journal of Electrical Engineering*, vol 50, pp. 284-288, 1999
- [11] D. Misir, H. A. Malki, and G. Chen, "Design and analysis of a fuzzy proportional-

- integral-derivative controller,” *International Journal of Fuzzy Sets and Systems*, vol. 79, pp. 297–314, 1996
- [12] J. Carvajal, G. Chen, and H. Ogmen, “Fuzzy PID controller: Design, performance evaluation, and stability analysis,” *Information Science*, vol. 123, pp. 249-270, 2000
- [13] Wei Wang, Han-Xiong Li and Jingto Zhang, “Intelligence based hybrid control for power plant boiler,” *IEEE Transactions on Control Systems Technology*, vol. 10, no. 2, pp. 280-287, March 2002
- [14] L. Debnath, “A brief historical introduction to fractional calculus,” *International Journal of Mathematical Education in Science and Technology*, vol. 35, pp. 487-501, 2004
- [15] J. S. Saini, M. Gopal and A. P. Mittal, “Genetic algorithm based PID tuner”, *IE(I) Journal*, vol. 85, pp. 216-221, 2005
- [16] Jun-Yi Cao, Jin Liang and Bing-Gang Cao, “Optimization of fractional PID controllers based on genetic algorithms,” *Proceedings of 4th International Conference on Machine Learning and Cybernetics*, pp. 5686-5689, 2005
- [17] F. Gao and H. Q. Tong, “A novel optimal PID tuning and online tuning based on particle swarm intelligence,” *Proceedings of International Conference on Sensing, Computing and Automation*, pp. 182-186, 2006
- [18] Y. Huang, N. Li, Y. Shi and Y. Yi, “Genetic adaptive control for drum level of a power plant boiler,” *Proceedings of IMACS multi conference on Computational Engineering in Systems Applications*, pp. 1965-1968, 2006
- [19] Z. Bi, Y. Pan, Q. Zhang and F. Wang, “An approach of PI gain scheduling with hysteresis switching for the control of a boiler drum level in the coal fired power generation units,” *Proceedings of 2006 IEEE International Conference on Control Applications*, pp. 1517-1521, 2006
- [20] K. Mrunalini, P. Kundu and K. K. Dutta, “State space model for drum boiler system,” *IE (I)*, vol. 86, pp. 260-267, Mar 2006
- [21] Schlegel Milos , C. Ech Martin, “The fractional order PID controller outperforms the classical one,” *Proceedings of 7th International Science & Technology Conference in Process Control*, pp. 1-7, 2006

- [22] Jun-Yi Cao and Bing-Gang Cao, "Design of fractional order controller based on particle swarm optimization," *International Journal of Control, Automation and Systems*, vol. 4, no. 6, pp. 775-781, 2006
- [23] Majid Zamani, Masoud Karimi-Ghartemani, Naseer Sadati, "FOPID controller design for robust performance using particle swarm optimization," *Fractional Calculus and Applied Analysis*, vol. 10, no. 2, pp. 169-187, 2007
- [24] Dingyu Xue, Chunna Zhao, YangQuan Chen, "Fractional order PID control of a DC motor with elastic shaft: A case study," *Proceedings of 2006 American Control Conference*, pp. 3182-3187, 2006
- [25] N. Phanthuna and T. Trongtirakul, "Improvement program for heat balance analysis fuel to steam efficiency boiler and wireless transducer controlled," *International Journal of Computers and Communications*, vol. 2, issue 3, pp. 69-76, 2008
- [26] Deepyaman Maiti, Sagnik Biswas and Amit Konar, "Design of a fractional order PID controller using particle swarm optimization technique," *Proceedings of Recent Trends in Information Systems '08*, 2008.
- [27] Andrezej Dzielinski and Dominik Sierociuk, "Simulation and experimental tools for fractional order control education," *Proc. IFAC'08*, 2008.
- [28] Varsha Bhambhani and YangQuan Chen, "Experimental study of fractional order PI controller for water level control," *Proceedings of IEEE Conference on Decision and Control*, pp. 1791-1796, 2008.
- [29] Ramiro S. Barbosa, J. A. Tenreiro Machado, Isabel S Jesus, "On the fractional PID control laboratory servo system," *Proceedings of 17th World Congress of the International Federation of Automatic Control*, pp. 15273-15278, 2008
- [30] Varsha Bhambhani, Yangquan Chen, Dingyu Xue, "Optimal fractional order proportional integral controller for varying time delay systems," *Proceedings of 17th World Congress of the International Federation of Automatic Control*, pp. 4910-4915, 2008
- [31] Mithun Chakraborty, Deepyaman Maiti and Amit Konar, "The application of stochastic optimization algorithms to the design of a fractional-order PID controller," *2008 IEEE Region 10 Colloquium and the Third International*

- Conference on Industrial and Information Systems, 2008, pp. 1-6, 2008
- [32] Chuang Zhao, Xiangde Zhang, "The application of fractional order PID controller to position servomechanism," Proceedings of 7th World Congress on Intelligent Control and Automation, pp. 3380-3383, 2008
- [33] Tushar Jain and M. J. Nigam, "Optimization of PD-PI controller using swarm intelligence," International Journal of Computational Cognition, vol. 6, no. 4, pp. 55-59, 2008
- [34] Jin-Sung Kim, Jin-Hwan Kim, Ji-Mo Park, Sung-Man Park, Won-Yong Choe and Hoon Heo," Auto tuning PID controller based on improved genetic algorithm for reverse osmosis plant", International Journal of Electrical and Computer Engineering, pp. 3-8, 2008
- [35] R. Vilanova, O. Arrieta, "PID tuning for cascade control system design", Canadian Conference on Electrical and Computer Engineering, pp. 001775, 2008
- [36] Hamid Bentarzi, Rabah Amr Chentir and Nikos E. Mastorakis, "A new method for controlling boiler of thermal power plant using fuzzy logic," Proceedings of 3rd International Conference on European Computing, pp. 31-34, 2009
- [37] Juan Garrido, Fernando Morilla and Francisco Vazquez, "Centralized PID control by decoupling of a boiler turbine unit," Proceedings of European Control Conference, pp. 4007-4012, 2009
- [38] Venu Kishore Kadiyala, Ravi Kumar Jatoth, Sake Pothalaiah," Design and implementation of fractional order PID controller for aerofin control system", World Congress on Nature and Biologically Inspired Computing, 2009
- [39] Yue Wei-Jie, Liu Yong-Xin, "Boiler drum level controlled by fuzzy self-adapting PID," Proceedings of 2009 Asia Pacific Conference Computational Intelligence and Industrial Applications, pp. 381-384, November 2009
- [40] Zang Haihe, Wang Li and Yu Xinjun, "Fuzzy controller of drum water level for industrial boiler," Proceedings of 2010 International Conference on Computer, Mechatronics, Control and Electronic Engineering, pp. 400-402, 2010
- [41] Yan Zhao, "Research on application of fuzzy PID controller in two-container water tank system control", International Conference on Machine Vision and

- Human-machine Interface, pp. 679 – 682, April 2010
- [42] Liang Chen, Cuizhu Wang, Yang Yu, Yawei Zhao,” The research on boiler drum water level control system based on self-adaptive fuzzy-PID”, Control and Decision Conference, pp. 1582 – 1584, May 2010
- [43] V. Mehra, S. Srivastava and P. Varshney, “Fractional-order PID controller design for speed control of DC motor,” 2010 Third International Conference on Emerging Trends in Engineering and Technology, pp 422-425, November 2010
- [44] Han Wenhua, Xu Jun, Sun Jianpeng, Yang Ping and Ren Haixia, “A study of MPSO-based PID controller on boiler drum water level,” Proceedings of 2011 Third International Conference on Measuring Technology and Mechatronics Automation, pp. 275-278, 2011