

PREPARATION AND CHARACTERIZATION OF NANOFUIDS

*A Thesis Report Submitted
in partial fulfillment of the requirements for
The award of Degree of*

**MASTER OF TECHNOLOGY
IN
CHEMICAL ENGINEERING**

Submitted by

**Gajendra Singh
Roll No.: 600911004**

Under the Supervision of

**Ms. Harkirat
Lecturer**

Department of Chemical Engineering

**Dr. D. Gangacharyulu
Professor**

Department of Chemical Engineering



**DEPARTMENT OF CHEMICAL ENGINEERING
THAPAR UNIVERSITY
PATIALA-147004, INDIA.**

July 2011

CERTIFICATE

I hereby declare that the work which is being presented in the thesis entitled "PREPARATION AND CHARACTERIZATION OF NANOFLUIDS" is an authentic record of my study carried out as requirements for the award of degree of **Master of Technology in Chemical Engineering Submitted in the Department of Chemical Engineering, Thapar University, Patiala**, under the guidance of **Dr. D. Gangacharyulu**, Professor and Head, and **Ms. Harkirat Kaur**, Lecturer, Department of Chemical Engineering, Thapar University, Patiala, Punjab, during Year **July 2010 to July 2011**.

The matter embodied in this thesis has not been submitted in part or full to any institute or any other university for the award of any degree.



(Gajendra Singh)

This is to certify that above declaration made by the student concerned is correct to the best of my knowledge and belief.

(**Harkirat Kaur**)
Lecturer
Department of Chemical Engineering
Thapar University, Patiala

(**D. Gangacharyulu**)
Professor
Department of Chemical Engineering
Thapar University, Patiala

Countersigned by:

(**D. Gangacharyulu**)
Head of the Department
Department of Chemical Engineering
Thapar University
Patiala-147004

(**S.K. Mohapatra**)
Dean of Academic Affairs
Thapar University
Patiala-147004

ACKNOWLEDGEMENT

No volumes of words are sufficient to express my gratitude towards my guides. I would like to thank all people who have helped and inspired me during my thesis project report work.

I especially want to thank **Dr. D. Gangacharyulu**, Professor, for his valuable advice, motivation, guidance, encouragement, moral support, sincere efforts were experimental in competition of this thesis during my research for providing all the facilities required for the completion of my thesis work and his cooperation and imparting his experience to me as a student, study at Thapar University, Patiala.

I am also very thankful to **Ms. Harkirat Kaur**, Lecturer in Chemical Engineering Department, and I express my gratitude towards my Co-Guide for their invaluable suggestion and commitment. Their assistance helps a long way in finishing my thesis. The generous support of all faculty and all staff members of Chemical Engineering department is greatly appreciated for their kind and valuable support which was indispensable towards my thesis completion. I would also like to thank lab assistants who made it a convivial place to work.

Furthermore, I am grateful to my friends and colleague who came across and supported at every step for accompanying me during the most outstanding year of my life and standing by me in every situation.

I would also like to thank my parents who support me in each and every step of my life. I take pride of myself being son of ideal parents for their everlasting desire, sacrifice, affectionate blessings, and help, without which it would not have been possible for me to complete my studies. Besides, I would like to acknowledge my institute i.e. **Thapar University**.

Last but not least, I would like to thank God for all good deeds and benevolence.

(GAJENDRA SINGH)

ABSTRACT

Nanofluids consist of nanometer- sized solid particles and fibers dispersed in liquids, have recently been demonstrated to have great potential for improving the heat transfer properties of liquids. In the development of energy-efficient heat transfer equipment, the thermal conductivity of the heat transfer fluid plays a vital role. However, traditional heat transfer fluids such as water, oil, and ethylene glycol mixtures are inherently poor heat transfer fluids. With increasing global competition industries have a strong need to develop advanced heat transfer fluids with significantly higher thermal conductivities than are presently available. The tested fluids are prepared by dispersing the Al_2O_3 into water at two different concentrations such as 0.5% and 1 %. Thermophysical properties of nanofluids are measured by KD2 Pro, Ubbelohde viscometer and specific gravity bottle. Experimental results show that thermal conductivity of nanofluids is higher than the base fluid and with increase in temperature it is increased from 3 % to 46 % (for 1 % particle concentration), and 1 % to 43 % (for 0.5 % particle concentration). Viscosity and density of nanofluids are decreasing with increase in temperature and but with increase in particle concentration, viscosity and density increased. The thermophysical properties which can be calculated by the experiments are quite high when it was compared with the respective theoretical models. And the values of all the models are quite same with each other.

CONTENTS

Chapter No.	Item Description	Page No.
	Contents	i-iii
	List of Figures	iv
	List of Tables	v
	Nomenclature and Symbols	vi
1	INTRODUCTION	1-6
1.1	Nanofluids	1
1.2	Nanofluid structure	3
1.3	Concerns of nanofluids	5
1.4	Epilogue	5
1.5	Objectives	6
	References	6
2	LITERATURE SURVEY	7-21
2.1	Preparation of nanofluids	7
2.2	Sonication	8
2.3	Characterizing of nanofluids	8
2.4	Synthesis of nanofluids	9
2.5	Applications of nanofluids	10
2.5.1	Crystal silicon mirror cooling	10
2.5.2	Electronics cooling	10
2.5.3	Vehicle cooling	10
2.5.4	Transformer cooling	10
2.5.5	Space and nuclear systems cooling	10
2.5.6	Nanofluids in transportation	11
2.5.7	In micromechanics and instrumentation	11
2.5.8	In heating, ventilating and air-conditioning (HVAC) systems	11

	2.5.9 Nuclear reactors	12
	2.5.10 Tribological applications	12
	2.5.11 Bio-medical applications	12
2.6	Epilogue	17
	References	18-20
3	EXPERIMENTAL WORK	21-28
3.1	Thermophysical properties	21
3.2	Equipment and Instruments used	21
	3.2.1 Ultra sonicator	21
	3.2.2 Thermal property analyzer	22
	3.2.3 Sensors: KS-1 single needle	23
	3.2.4 TR-1 single needle	24
	3.2.5 SH-1 dual needle	25
3.3	Ubbelohde viscometer	26
3.4	Specific gravity bottle	28
4	MATERIALS AND METHODOLOGY	29-30
4.1	Introduction	29
4.2	Materials required	29
	4.2.1 Materials used for preparing nanofluids	29
4.3	Methodology	29
	4.3.1 Preparation of nanofluids	29
	4.3.2 Thermophysical properties measurement	29
5	RESULTS AND DISCUSSIONS	31-43
5.1	Thermal conductivity measurement	31
	5.1.1 Thermal conductivity measurement at different temperatures by KD2 Pro	31

5.1.2	Thermal conductivity at different temperatures from Maxwell model	32
5.1.3	Thermal conductivity at different temperatures from Hamilton Crosser model	33
5.1.4	Thermal conductivity at different temperatures from Jeffery model	34
5.2	Viscosity measurement	36
5.2.1	Viscosity from Einstein model	37
5.2.2	Viscosity from Brinkman model	38
5.2.3	Viscosity from Lundgen model	39
5.2.4	Viscosity from Kerieger and Dougherty model	39
5.2.5	Viscosity from Nielsen's model	40
5.3	Density measurement	42
6	CONCLUSIONS	44
7	FUTURE RECOMMENDATIONS	45

LIST OF FIGURES

Figure No.	Item Description	Page No.
1.1	Nanofluid Structure	3
1.2	Synthesis of nanofluids	4
2.1	Laser ablation technique	7
2.2	Sonicator	8
3.1	Ultra sonicator	22
3.2	Thermal analyzer (KD2 Pro)	23
3.3	KS-1 single needle	24
3.4	TR-1 sensor needle	25
3.5	SH-1 dual needle	26
3.6	Ubbelohde -viscometer with temperature bath	27
3.7	Ubbelohde- viscometer	27
3.8	Specific gravity bottle	28
5.1	Comparison of thermal conductivity for 1% and 0.5% (Al_2O_3) nanofluids by volume	32
5.2	Comparisons of experimental values of thermal conductivity with various models for 1% Al_2O_3 nanofluids by volume	35
5.3	Comparisons of experimental values of thermal conductivity with various models for 0.5% Al_2O_3 nanofluids by volume	35
5.4	Variation of viscosity of nanofluids (Al_2O_3) with temperatures for 1% and 0.5% by volume	37
5.5	Comparisons of experimental values of viscosity with various models for 1% Al_2O_3 nanofluids by volume	41
5.6	Comparisons of experimental values of viscosity with various models for 0.5% Al_2O_3 nanofluids by volume	41
5.7	Variation of density of nanofluids (Al_2O_3) at different temperatures	43

LIST OF TABLES

Table No.	Item Description	Page No.
1.1	Types of nanofluids	3
1.2	Comparisons of nanoparticles versus microparticles	5
5.1	Values of thermal conductivity by KD2 Pro for 1 % Al ₂ O ₃ nanofluids by volume	31
5.2	Values of Thermal conductivity by KD2 Pro for 0.5 % Al ₂ O ₃ nanofluids by Volume	31
5.3	Values of thermal conductivity at different temperatures for Maxwell model	33
5.4	Values of thermal conductivity at different temperatures for Hamilton Crosser model	34
5.5	Values of thermal conductivity at different temperatures for Jeffery model	34
5.6	Time taken for distilled water by Ubbelohde viscometer	36
5.7	Time taken for 1% Al ₂ O ₃ nanofluids by Ubbelohde viscometer	36
5.8	Time taken for 0.5% Al ₂ O ₃ nanofluids by Ubbelohde viscometer	36
5.9	Viscosity at temperatures for 1 %, 0.5 % Al ₂ O ₃ nanofluids	37
5.10	Values of viscosity from Einstein model for 1% and 0.5% volume concentration of Al ₂ O ₃ – water nanofluids	38
5.11	Values of viscosity from Brinkman model for 1% and 0.5% volume concentration of Al ₂ O ₃ – water nanofluids	38
5.12	Values of viscosity from Lundgen model for 1% and 0.5% volume concentration of Al ₂ O ₃ – water nanofluids	39
5.13	Values of viscosity from Kerieger and Dougherty model for 1% and 0.5% volume concentration of Al ₂ O ₃ – water nanofluids	40
5.14	Values of viscosity from Nielsen's model for 1% and 0.5% volume concentration of Al ₂ O ₃ – water nanofluids	40
5.15	Net weight of Distilled water and 1% and 0.5% Al ₂ O ₃ at temperatures	42
5.16	Value of density at different temperature for 1% and 0.5% Al ₂ O ₃ nanofluids	42

NOMENCLATURE AND SYMBOLS

Symbol	Description
C _p	Volumetric specific heat, MJ/ (m ³ .K)
ρ	Density, kg/m ³
K	Thermal conductivity, W/(m.K)
μ	Viscosity, cP
t	Time, seconds
T	Temperature, °C
%	Percentage
°C	Degree Celsius
ng	Nanograms
Cu	Copper
Si	Silicon
uA	Micro ampere
μL	Micro liters
nM	Nanomolar
W	Watt
K	Kelvin
MJ	Mega Joules
cP	Centi Poise
Al ₂ O ₃	Aluminum Oxide
AuNPs	Gold nanoparticles

CHAPTER – 1

INTRODUCTION

Many industrial applications need ultrahigh-performance cooling systems to miniaturize the thermal systems, and need for high performance cooling. Nanofluids as a new, innovative class of heat transfer fluids represent a rapidly emerging field where nano science and thermal engineering coexist. The latest literature reveals that the using of nanofluids in thermal systems of the best options.

1.1 Nanofluids

Nanofluids are engineered colloidal suspension of nanoparticles (1-100 nm) in a base fluid. Nanofluids are generally defined as suspension of nanometer sized particles that enhance the properties of the parent fluids. Common base fluid includes water and organic liquids. They are used for the enhancement of thermal conductivity. Nanoparticles are typically made of chemically stable metals, metal oxides or carbon in a various forms. The size of the nanoparticles imparts some unique characteristics to the these fluids, including greatly enhanced energy momentum and mass transfer, as well as reduced tendency for sedimentation and erosion of the containing surfaces. Nanofluids have unique features different from conventional solid liquid mixtures in which mm or μm sized particles of metals and non metals are dispersed. Due to their excellent characteristics, nanofluids find wide applications in enhancing heat transfer [1].

Nanofluids (Nanoparticles fluid suspensions) is the term coined by Choi (1995) to describe this new class of nanotechnology based heat transfer fluids that exhibit thermal properties superior to those of their host fluids or conventional particle fluid suspension . Nanofluids are stable colloidal suspensions of nanoparticles, nanofibers, nanocomposite in common base fluids. Nanoparticles are very small, nanometer-sized particles with dimensions usually less than 100 nm. The smallest nanoparticles, only a few nanometers in diameter, contain only a few thousand atoms. These nanoparticles can possess properties that are substantially different from their parent materials. Similarly, nanofluids may have properties that are substantially different from their base fluids, like much higher thermal conductivity, among others [2]. Nanoparticles are used because they stay in solution longer than larger particles, and a high surface area for thermal conductivity. Solids are used as fillers because they have a higher thermal conductivity than liquids. Nanoparticles are especially well suited for use in heat transfer suspension. Nanofluids are stable colloidal suspension

of nanoparticles, nanofibers or nanocomposite in common, base fluids, such water, oil, ethylene-glycol mixture (antifreeze), polymer solution, etc. Nanoparticles are very small, nanometer-sized particles with dimensions usually around 10 nanometers (10 nm) [roughly corresponds to the transition from molecule to particle] but less than 100 nanometers (100 nm) [one nanometer is one billionth of meter or one thousandth of micrometer, $[1 \mu\text{m} = 1000 \text{ nm}]$. For comparison, less than 10 lines atom will span one nanometer length, a human hair is about 50,000 nm in diameter, while a smoke particle is about 1,000 nm in diameter. For example, the carbon nano tubes discovered in 1990s, are extremely thin [only several nanometer diameter], hollow cylinders made of thin layer or even single-atom-layer carbon atoms. The goal of nanofluids is to achieve the highest possible thermal properties at the smallest possible concentrations (preferably $< 1\%$ by volume) by uniform dispersion and stable suspension of nanoparticles (preferably $< 10 \text{ nm}$) in host fluids. Three available methods of generating these nanofluids are: (i) creating them from chemical precipitation, (ii) purchasing the nanoparticles in powder form and mixing them with the base fluid, and (iii) direct purchase of prepared nanofluids. Characterization of nanofluids includes colloidal stability, size distribution, concentration, and elemental composition. Quality control of the nanofluids to be used for heat transfer testing is crucial; an exact knowledge of the fluid constituents is a key to uncovering mechanisms responsible for heat transport enhancement. The smallest nanoparticles, only a few nanometers in diameter, contain only a few thousand atoms. These nanoparticles, can process properties that are substantially different from their parent materials. Similarly, nanofluids may have properties that are substantially different from their base fluids, like much higher thermal conductivity, etc. [1].

Nature is full of nanofluids, like blood, a complex biological nanofluid where different nanoparticles [at molecular level] accomplish different functions. By studying nanofluids in the lab and the nature, using new and available experimental techniques, and developing computer based models of these fluids and related phenomena. New methods and tools for costume-design of nanofluids with enhanced properties and functions may be developed. Possible applications, like electronics, nuclear and bio-medical instrumentation and equipments, transportation and industrial cooling, heat management in various critical applications, as well as environmental control and cleanup, bio- medical application, and direct self assembly of nanostructure, which usually start from suspensions of nano-particles in fluid [3].

1.2 Nanofluid Structure

Although liquid molecules close to a solid surface are known to form layered structures, little is known about the interactions between these nanolayers and thermo-physical properties of these solid/liquid nano-suspensions. ANL team (Choi et al.) proposed that the nanolayer acts as a thermal bridge between solid nanoparticle and a bulk liquid and so it is a key to enhancing thermal conductivity. A structural model of nanofluids that consists of solid nanoparticles, bulk liquid and solid-like nanolayers is hypothesized.

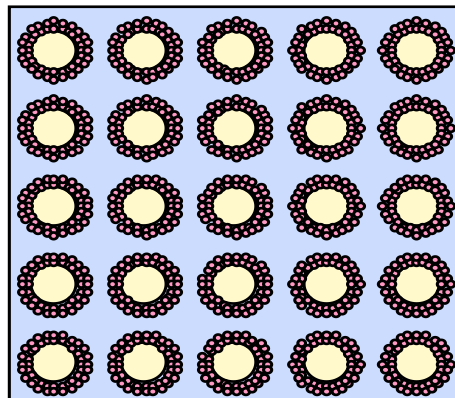

Figure No.1.1: Nanofluid Structure

Table 1.1: Types of Nanofluids

S. No.	Description	Examples
1.	Base fluid:	Water, organic liquid, oil and other lubricants bio-fluids, polymer solution, Ethylene or triethylene-glycols and other coolants, other common fluids.
2.	Nanoparticles size:	1-100 nm
3.	Nanoparticles Materials include:	
	Oxides ceramics	Al ₂ O ₃ and CuO
	Metal carbides	SiC
	Metals	Al and Cu
	Nitrides	AlN and SiN
	Nonmetals	Graphite and carbon nanotubes
	Layered	Al+Al ₂ O ₃ and Cu+C

Synthesis of Nanofluids

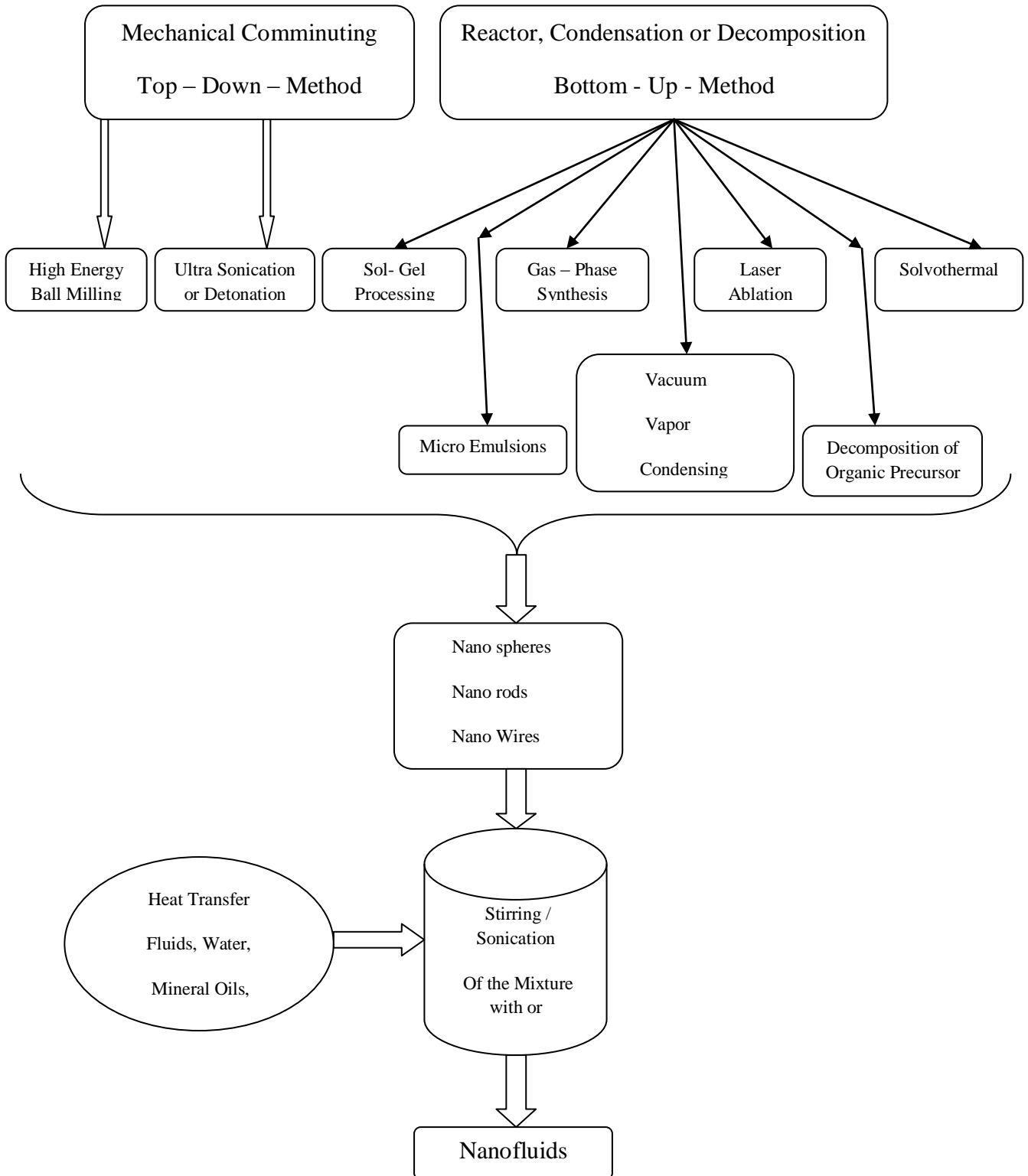

Figure No. 1.2: Synthesis of Nanofluids

Table 1.2: Comparisons of Nanoparticles vs Microparticles

S. No.	Description	Nanoparticles
1.	Stability	Stable remain in suspension almost indefinitely
2.	Surface/volume ratio	1,000 times larger than that of micro particles
3.	Conductivity	High
4.	Clog in Micro channel	No
5.	Erosion	No
6.	Pumping power	Small
7.	Nanoscale phenomena	Yes

1.3 Concerns of Nanofluids

- Dispersability of nanoparticles,
- Stability of nanoparticles in base fluids,
- Chemical compatibility of nanoparticles and base fluids, and
- Thermal stability of nanofluids.

1.4 Epilogue

More than ever before, cooling is one of the most pressing challenges of many technologies nowadays. Many efforts have been made trying to disperse nanoparticles into HTFs to make nanofluids with enhanced thermal transport properties. Nanoparticles of oxides and metals, carbon nanotubes and other nanostructures have been used. Thermal conductivity, heat transfer coefficient in convective environments, and viscosity of many nanofluids has been investigated. Experimental and theoretical studies have shown that if prepared properly, nanofluids have attracting characteristics that make them ideal for cooling systems. Their improved thermal transport properties allows for the dissipation of more thermal energy even by using less coolant. Engine oils, automatic transmission fluids, fluorocarbons, and other synthetic heat transfer fluids all possess poor heat transfer capabilities and so they could benefit from the high thermal conductivity offered by nanofluid techniques.

1.5 Objectives

1. To prepare Al_2O_3 nanofluids by dispersing Al_2O_3 nanoparticle in base fluid i.e. distilled water.
2. To measure the thermal Conductivity, density and viscosity of nanofluids with in temperature range of 25°C to 90°C .
3. To compare the experimental values with the theoretical values calculating from various theoretical models.

References

1. Singh, A. K., (2008), "Thermal Conductivity of Nanofluids," Defence Science Journal, 58 (5), pp. 600-607.
2. Das, S.K., Choi, S.U.S, Wenhua, Y. and Pradeep, T., (2007), "Nanofluids: Science and Technology," John Wiley & Sons, pp. 1-2.
3. Kostic, M.M., (2006), "Critical issues and application potentials in nanofluids research," MN2006-17036, Proceedings of Multifunctional Nanocomposites, pp. 1-9.

CHAPTER - 2

LITERATURE SURVEY

Various studies on nanofluids were carried out by many researchers in the past. Chapter reviews the previous published literatures, which lays foundation and basis for further work in this investigation. This helps to give a better understanding about the topic and also acts as a guideline for this thesis. The major focus of the following study is on the nanofluids and its applications in various areas. This section deals with literature review on nanofluids, its preparation and characterization, thermo-physical properties of nanofluids, characterizing of nanofluids, applications of nanofluids and synthesis of nanofluids.

2.1 Preparation of Nanofluids

Nanofluids are prepared by any one of the method either by two step process or by laser ablation technique. Previous efforts to manufacture nanofluids have often employed either a single step that simultaneously makes and disperses the nanoparticles into base fluids, or a two-step approach that involves generating nanoparticles and subsequently dispersing them into a base fluid. Using either of these two approaches, nanoparticles are inherently produced from processes that involve reduction reactions or ion exchange. Another difficulty encountered in nanofluid manufacture is nanoparticles tendency to agglomerate into larger particles, which limits the benefits of the high surface area nanoparticles. Unfortunately, this practice can change the surface properties of the particles, and nanofluids prepared in this way may contain unacceptable levels of impurities. To overcome this problem a single-step method is founded on the laser ablation of solid metals or polymers which are submerged in the base fluid that will simultaneously make and disperse nanoparticles directly in the base fluids (water, lubrication oils, etc.). [1]

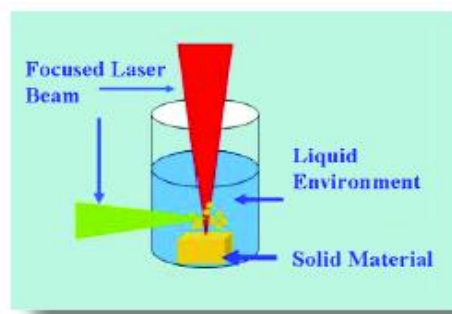

Figure No 2.1: Laser Ablation Technique

2.2 Sonication

Sonication is the act of applying sound energy to agitate particles in a sample vessel for various purposes. In the laboratory, it is usually applied using an ultrasonic bath vessel known as a sonicator. Sonication can be used to speed dissolution, by breaking intermolecular interactions. It may also be used to provide the energy for certain chemical reactions to proceed. Sonication can be used to remove dissolved gases from liquids (degassing) by sonicating the liquid while it is under a vacuum. This is an alternative to the freeze-pump-thaw and sparging methods.



Figure No. 2.2: Sonicator

Sonication is commonly used in nanotechnology for evenly dispersing nanoparticles in liquids. This is done after preparing the nanofluids.

2.3 Characterizing of Nanofluids

A simplistic approach makes use of particle size analyzer based on dynamic light scattering (DLS) [2]. Imaging analysis of nanofluids is done using electron microscope (SEM/TEM, TEM being preferred over SEM for nanofluids) and most of the reported studies makes use of TEM for characterizing nanofluids. Cryogenic transmission electron microscopy might provide a powerful characterization method, but few laboratories are equipped to apply this technique. Scanning probe

microscopy (SPM) has not found much use for characterizing nanofluids. Another valuable characterization tool for the structure of suspensions at nanoscale is the small angle x-ray scattering (SAXS) and small angle neutron scattering (SANS) [3].

2.4 Synthesis of Nanofluids

Synthesis of nanofluids carried out by mixing nano particles with fluids. Since then, there has been rapid development in the synthesis techniques for nanofluids. However, there is not yet a standard preparation method for nanofluids. Different studies prepared nanofluids using different approaches. There are two fundamental methods to obtain nanofluids:

- a). Two-step process, first, nanoparticles are produced as a dry powder, typically by inert gas condensation. The second step involves dispersion of dry nanoparticle powder into a base fluid, like water, oil or ethylene-glycol [4].
- b). Romano et al. Reported an advantage of the two-step process is that the inert-gas condensation technique has been scaled up to commercial nano powder production. A deficiency of this method is the tendency of nano powder to agglomerate during storage and dispersion in the base fluids, particularly with heavier metallic nanoparticles. Surfactants and other surface-stabilization additives can be used to achieve more homogeneous and more stable suspensions. In addition to mechanical mixing, ultra-sonic mixers can be used to break up agglomerates and give more uniform dispersions [5].
- c). Chemical approach using wet technology, a single-step approach, is emerging as a powerful method for growing nanostructures of different metals, semiconductors, non- metals, and hybrid systems. Laser ablation is another much sought, single-step technique that simultaneously makes and disperses nanoparticles directly in the base fluids [6 & 7].
- d). A variety of nanofluids have been prepared by laser ablation method by ablating solid metals, semiconductors, etc which are submerged in the base fluid (water, lubrication oils, etc). By creating a nanofluid in this way, stable nanofluids resulted without using any property-changing dispersants. This method is also useful for further splitting of nanoparticles present in the nanofluids to study effect of particle size on thermal conductivity [8-11].
- e). Singh and Raykar et al. gives another one step approach that is adopted for nanofluids synthesis based on microwave irradiation and is a quick method of nanofluid synthesis and used submerged arc nano-synthesis system (SANSS) for preparing nanofluids [12-14].

2.5 Applications of Nanofluids

Nanofluids are an exciting new category of more efficient heat transfer fluids that have the potential to greatly improve upon thermal management systems in a wide variety of applications, owing to their increased thermal conductivity and long term stability [15].

Some of the Applications of Nanofluids are as follows:

2.5.1 Crystal Silicon Mirror cooling: One of the first applications of research in the field of nanofluids is for developing an advanced cooling technology to cool crystal silicon mirrors used in high intensity X-ray sources. Experiments are carried out to estimate the performance of micro channel heat exchangers with water, liquid nitrogen and nanofluids as the working fluid [16].

2.5.2 Electronics cooling: Lee, S., and S. U. S. were probably the first to show experimentally that the thermal performance of heat pipes can be enhanced by nearly a factor 2 when nanofluids are used. Water based nanofluids are used containing 17 nm gold nanoparticle as the working fluid in a disk shaped miniature heat pipe (DMHP). Then, measured the thermal resistance of the DMHP with both nanofluids and deionized (DI) water. The results show that thermal resistance of a DMHP is reduced significantly (40%) when nanofluids are used instead of DI water [17].

2.5.3 Vehicle cooling: Nanoparticles can be dispersed not only in coolants and engine oils, but in transmission fluids, gear oils, and other fluids and lubricants. These may provide better overall thermal management and better lubrication were probably the first to apply nanofluid research in cooling a real-world automatic power transmission system. They dispersed CuO and Al₂O₃ nanoparticles into automatic transmission oil to investigate the optimum possible compositions of a nanofluid for higher heat transfer performance [18].

2.5.4 Transformer cooling: The power generation industry is interested in transformer cooling application of nanofluids for reducing transformer size and weight. If the heat transfer capability of existing transformers can be increased, many of the upgrades may not be necessary have demonstrated that the heat transfer properties of transformer oil can be improved by using nanoparticles additives [19 & 20].

2.5.5 Space and Nuclear Systems cooling: have discovered the unprecedented phenomenon that nanofluids can double or triple the CHF in pool boiling. Found that the high surface wet ability

caused by nanoparticles deposition can explain this remarkable thermal property of nanofluid. The work is important in developing realistic predictive models of the CHF in nanofluids. The ability to greatly increase the CHF, the upper heat flux limit in nucleate boiling systems, is of paramount practical importance to ultra-high heat flux devices that use nucleate boiling, such as high power lasers and nuclear reactor components. Therefore nanofluids opened up exciting possibilities for raising chip power in electronic devices or simplifying cooling requirements for space applications [21 & 22].

2.5.6 Nanofluids in transportation: The transportation industry has a strong demand to improve performance of vehicle heat transfer fluids and enhancement in cooling technologies is also desired. Because engine coolants, engine oils, automatic transmission fluids, and other synthetic high temperature fluids currently possess inherently poor heat transfer capabilities, they could benefit from the high thermal conductivity offered by nanofluids. Nanofluids would allow for smaller, lighter engines, pumps, radiators, and other components. Lighter vehicles could travel further on the same amount of fuel i.e. more mileage per liter. More energy-efficient vehicles would save money. Moreover, burning less fuel would result in lower emissions and thus reduce environment pollution. Therefore, in transportation systems, nanofluids can contribute greatly.

2.5.7 Nanofluids in micromechanics and instrumentation: Since 1960s, miniaturization has been a major trend in science and technology. Micro electromechanical systems (MEMS) generate a lot of heat during operation. Conventional coolants do not work well with high-power MEMS because they do not have enough cooling capability. Moreover, even if large-sized solid particles were added to these coolants to enhance their thermal conductivity, they still could not be applied in practical cooling systems, because the particles would be too big to flow smoothly in the extremely narrow cooling channels required by MEMS. Since nanofluids can flow in micro channels without clogging, they would be suitable coolants. They could enhance cooling of MEMS under extreme heat flux conditions.

2.5.8 Nanofluids in heating, ventilating and air-conditioning (HVAC) systems: Nanofluids could improve heat transfer capabilities of current industrial HVAC and refrigeration systems. Many innovative concepts are being considered; one involves pumping of coolant from one location where the refrigeration unit is housed in another location. Nanofluid technology could make the process more energy efficient and cost effective.

2.5.9 Nanofluids in Nuclear Reactors: at the nuclear Science and Engineering Department of the Massachusetts Institute of Technology (MIT), performed a study to assess the feasibility of nanofluids in nuclear applications by improving the performance of any water-cooled nuclear system that is heat-removal limited. Possible applications include pressurized water reactor (PWR) primary coolant, stand-by safety system, accelerator targets, and plasma diverters. In a pressurized water reactor (PWR) nuclear power plant system, the limiting process in the generation of the system is critical heat flux (CHF) between the fuel rods and the water – when vapor bubbles that end up covering the surface of the fuel rods conduct very little heat as opposed to the liquid water. Using nanofluids instead of water, the fuel rods become coated with the nanoparticles such as alumina, which actually push newly formed bubbles away, preventing the formation of a layer of vapor around the rod and subsequently increasing the CHF significantly [23].

2.5.10 Tribological Applications

Nanofluid technology can help develop better oil and lubricants. Recent nanofluid activity involves the use of nanoparticles in lubricants to enhance tribological properties of lubricants, such as load-carrying capacity and anti-wear and friction-reducing properties between moving mechanical components. Performed experimentally in lubrication applications and reported that surface-modified nanoparticles stably dispersed in mineral oils are very effective in reducing wear and enhancing load-carrying capacity [24].

2.5.11 Bio-medical Applications

Nanofluids were originally developed primarily for thermal management applications such as engine, microelectronics, and photonics. However, nanofluids can be formulated for a variety of other uses for faster cooling. Nanofluids are being developed for medical applications, including cancer therapy. Suggested that iron-based nanoparticles can be used as delivery vehicles for drugs or radiation without damaging nearby healthy tissue by guiding the particles up the bloodstream to a tumor with magnets. In contrast to cooling, nanofluids could be used to produce higher temperatures around tumors, to kill cancerous cells without affecting nearby healthy cells [25].

Ravnik et al. has worked on analysis of three-dimensional natural convection of nanofluid. They analyze flow and heat transfer characteristics of nanofluids in natural convection flows in closed cavities. They consider two test cases: natural convection in a three-dimensional differentially heated cavity, and flow around a hot strip located in two positions within a cavity. Simulations

were performed for Rayleigh number values ranging from 10³ to 10⁶. Performance of three types of water based nanofluids was compared with pure water and air.

With the advancement of engineering technology there comes an increasing demand for cooling. Efficient cooling is one of the most important challenges. Low thermal conductivity of working fluids such as water, oil or ethylene glycol led to the introduction of nanofluids, which represent a novel approach to cooling. Nanofluid is a suspension consisting of uniformly dispersed and suspended nanometer-sized (10–50 nm) particles in base fluid, pioneered by Choi. Nanofluids have very high thermal conductivities at very low nanoparticle concentrations and exhibit considerable enhancement of convection. Intensive research in the field of nanofluids started only a decade ago. A wide variety of experimental and theoretical investigations have been performed, as well as several nanofluid preparation techniques have been proposed. Buoyancy induced flow and heat transfer is an important phenomenon used in various engineering systems. Several researchers have been focusing on buoyant flow of nanofluids [26].

Abu-Nada and Oztop performed a two-dimensional study of natural convection of various nanofluids in partially heated rectangular cavities, reporting that the type of nanofluid is a key factor for heat transfer enhancement. They obtained the best results with Cu–water nanofluid. The same researchers examined the effects of inclination angle on natural convection in enclosures filled with Cu–water nanofluid. They reported that the effect of nanofluid on heat enhancement is more pronounced at higher Rayleigh numbers [27].

Wang et al. studied natural convection of a water based Al₂O₃ nanofluid. They investigated convective instability of the flow and transfer and reported that the natural convection of a heat nanofluid becomes more stable when the volume fraction of nanoparticles increases. They demonstrated that usage of different models for viscosity and thermal conductivity does indeed have a significant impact on heat transfer. Natural convection of nanofluids in an inclined differentially heated square enclosure was studied by, using polynomial differential quadrature method [28].

Ravikanth has worked on experimental determination of thermal conductivity of three nanofluids and development of new correlations. Experimental investigations have been carried out for determining the thermal conductivity of three nanofluids containing aluminum oxide, copper oxide and zinc oxide nanoparticles dispersed in a base fluid of 60:40 (by mass) ethylene glycol and water

mixture. Particle volumetric concentration tested was up to 10% and the temperature range of the experiments was from 298 to 363 K. The results show an increase in the thermal conductivity of nanofluids compared to the base fluids with an increasing volumetric concentration of nanoparticles. The thermal conductivity also increases substantially with an increase in temperature. Several existing models for thermal conductivity were compared with the experimental data obtained from these nanofluids, and they do not exhibit good agreement. Therefore, a model was developed, which is a refinement of an existing model, which incorporates the classical Maxwell model and the Brownian motion effect to account for the thermal conductivity of nanofluids as a function of temperature, particle volumetric concentration, the properties of nanoparticles, and the base fluid, which agrees well with the experimental data [29].

According to the effective thermal conductivity of ethylene glycol is increased by up to 40% when 0.3 volumetric percent of copper nanoparticles of mean diameter less than 10 nm are dispersed in it. From heat transfer theory, for a constant, Nusselt number, the convective heat transfer coefficient is directly proportional to the thermal conductivity. With this observation, many researchers have been motivated to determine the thermal conductivity of nanofluids accurately [30].

A combined experimental and theoretical study on the effective thermal conductivity and viscosity of nanofluids is conducted. The thermal conductivity and viscosity of nanofluids are measured and found to be substantially higher than the values of the base fluids. Both the thermal conductivity and viscosity of nanofluids increase with the nanoparticle volume fraction. The thermal conductivity of nanofluids was also observed to be strongly dependent on temperature. Two static mechanisms-based models are presented to predict the enhanced thermal conductivity of nanofluids having spherical and cylindrical nanoparticles. The proposed models show reasonably good agreement with the experimental results and give better predictions for the effective thermal conductivity of nanofluids compared to existing classical models. Based on the calibration results from the transient hot-wire method, the measurement error was estimated to be within 2%. In addition, the measured values of the effective viscosity of nanofluids are found to be underestimated by classical models. Nanofluids, which are suspensions of nanoparticles in conventional fluids such as water, ethylene glycol and engine oil, have attracted great interest from many researchers due to their potential benefits and applications in important fields such as microelectronics, energy supply, and transportation [31].

From investigations in the past decade, nanofluids were found to exhibit substantially higher thermal properties particularly thermal conductivity even when the concentrations of suspended nanoparticles are very low ($\phi < 5\%$). However, the increments of thermal conductivities are different for different types of nanofluids. The thermal conductivity of nanofluids varies with the size, shape, and material of nanoparticles. For example, nanofluids with metallic nanoparticles were found to have a higher thermal conductivity than nanofluids with nonmetallic (oxide) nanoparticles. The smaller the particle size, the higher the thermal conductivities of nanofluids. Furthermore, nanofluids with spherical shape nanoparticles exhibit a smaller increase in thermal conductivity compared with the nanofluids having cylindrical (nano-rod or tube) nanoparticles. In addition, temperature may play an important role in enhancing the effective thermal conductivity of nanofluids. As reported in the literature, most experimental studies on the determination of the thermal conductivity of nanofluids have been conducted at room temperature. Very few studies have been performed to investigate the temperature effect on the effective thermal conductivity of nanofluids. Hence, to confirm the effects of these parameters on the effective thermal conductivity of nanofluids, more experimental studies are essential. Thus, in this paper, the effective thermal conductivity of several types of nanofluids was measured by the transient hot-wire method at different temperatures. The existing classical models such as those attributed to Maxwell, Hamilton–Crosser (HC) and Bruggeman were found to be unable to predict the anomalously high thermal conductivity of nanofluids. This is because these classical models do not include the effects of particle size, distribution and the interfacial layer at the particle/liquid interface which are considered as important mechanisms for enhancing thermal conductivity of nanofluids. The thermo physical properties of the interfacial layer are different from the bulk liquid and solid particles. The effective thermal conductivity and viscosity of nanofluids were found to significantly increase with the particle volume fraction. A linear increase in the effective thermal conductivity of nanofluids with temperature was also observed. The proposed models, which consider particle size, interfacial layer, and volume fraction, show good agreement with the experimental results and give better predictions for the thermal conductivity of nanofluids compared to the existing models. Besides the volume fraction of particle, it can also be concluded that particle size, shape, interfacial layer, and temperature also influence the thermal conductivity of nanofluids. The effect of temperature on the enhanced effective thermal conductivity of nanofluids is important for theoretical understanding and needs to be considered for the model development. The enhancement of viscosity may diminish the effectiveness of nanofluids in practical applications [32].

Xue et al. measured an expression for the effective thermal conductivity of nanofluids with interfacial shells. Comparing with conventional models, the expression is not only depended on the thermal conductivity of the solid and liquid and their relative volume fraction, but also depended on the particle size and interfacial properties. The theoretical results on the effective thermal conductivity of CuO/water and CuO/ethylene glycol nanofluids are in good agreement with the experimental data [33].

Tavman et al. measured the effective thermal conductivity by using 3ω method and effective viscosity by vibro-viscometer for SiO₂-water and Al₂O₃-water nanofluids at different particle concentrations and temperatures. The effective thermal conductivity of nanofluids is measured by a technique based on a hot wire thermal probe with ac excitation and 3ω lock-in detection. There is presented an experimental study of thermal conductivity and viscosity of nanofluids. It was investigated Alumina and Silica nanoparticles in water with different particle concentrations. Measured results showed that the effective thermal conductivity of nanofluids increase as the concentration of the particles increase but not anomalously as indicated in the majority of the literature and this enhancement is very close to Hamilton-Crosser model, also this increase is independent of the temperature. The effective viscosities of these nanofluids increased by the increasing particle concentration and decrease by the increase in temperature, and can not be predicted by Einstein model. The results show that for our samples, thermal conductivity values are inside the limits of (moderately lower than) Hamilton-Crosser model. Experiments at different temperatures show that relative thermal conductivity of nanofluids is not related with the temperature of the fluid [34].

Fei Duan has done an investigation on viscosity which was conducted 2 weeks after the Al₂O₃-water nanofluids having dispersants were prepared at the volume concentration of 1-5%. The shear stress was observed with a non-newtonian behavior. On further ultrasonic treatment, the nanofluids resumed as a Newtonian fluids. The relative viscosity increases as volume concentrations increases. At 5% volume concentration, an increment was about 60% in the result sonication nanofluids in comparison with the base fluid. The microstructure analysis indicates that higher nanoparticles aggregation had been observed in the nanofluids before re-ultra sonication [35].

Clement Kleinstreuer and Yu Feng investigated the nanofluids, i.e., well-dispersed (metallic) nanoparticles at low- volume fractions in liquids, may enhance the mixture's thermal conductivity, knf, over the base-fluid values. Thus, they are potentially useful for advanced cooling of micro-systems. It is evident that key questions still linger concerning the best nanoparticle-and-liquid pairing and conditioning, reliable measurements of achievable knf values, and easy-to-use, physically sound computer models which fully describe the particle dynamics and heat transfer of nanofluids. At present, experimental data and measurement methods are lacking consistency. In fact, debates on whether the anomalous enhancement is real or not endure, as well as discussions on what are repeatable correlations between knf and temperature, nanoparticles size/shape, and aggregation state. Clearly, benchmark experiments are needed, using the same nanofluids subject to different measurement methods. Such outcomes would validate new, minimally intrusive techniques and verify the reproducibility of experimental results. Dynamic knf models, assuming non-interacting metallic nano-spheres, postulate an enhancement above the classical Maxwell theory and thereby provide potentially additional physical insight. Clearly, it will be necessary to consider not only one possible mechanism but combine several mechanisms and compare predictive results to new benchmark experimental data sets [36].

Madhusree Kole and Dey measured the viscosity of the nanofluids which was prepared by dispersing alumina nanoparticles (< 50nm) in commercial car coolant. The nanofluid prepared with calculated amount of oleic acid (surfactant) was tested to be stable for more than 80days.the viscosity of nanofluids is measured both as a function of alumina volume fraction and temperature between 10 and 50°C.while the pure base fluid display Newtonian behavior over the measured temperature, addition of a small amount of alumina nanoparticles and viscosity of the nanofluid increases with increasing nanoparticles concentration and decreases with increase in temperature. Most of the frequently used classical models severely under predict the measured viscosity. Volume fraction dependence of the nanofluid viscosity, however, is predicted fairly well on the basis of a recently reported theoretical model for nanofluids that takes into account the effect of Brownian motion of nanoparticles in the nanofluid. The temperature dependence of the viscosity of engine coolant based alumina nanofluids obeys the empirical correlation of the type:

$$\log(\mu_{n-f}) = A \exp(BT), \text{ proposed [37].}$$

2.6 Epilogue

In this chapter, the literature review carried out to describe and discuss about nanofluids, its thermal properties, preparation and characterization and thermophysical properties. The applications of nanofluids in heat transfer area have also high lightened. In today's science, nanofluids play a major role in various areas due to their unique characteristics. According to the literature, still there very few researches are carried out on nanofluids properties and its applications. In this thesis, our main work is to find out the thermophysical properties of nanofluids and then compared with the various models.

References

1. Phuoc, X., Tran, Yee, S. and David, K. L., (2007), "Nanofluids preparation using multipulse laser ablation technique," R& D facts. pp. 1-2.
2. Robert, Hunter, J., (1989), "Foundations of Colloid Science," (Oxford University Press, Oxford).
3. Lurio, L. B., Lumma, D., Borthwick, M. A., Falus, P., Mochrie, S. G. J., Pelletier and Sutton M.J.F., (2000), "Creating Coherent X-rays and Putting them to Use: X-Ray Photon Correlation Spectroscopy at Beamline 8-ID at the Advanced Photon Source," Synchrotron Radiat News, 13, pp. 28-38.
4. Granqvist, and Buhrman, R.A., (1976), "Ultra-fine metal particles," J. Application Physics, 47, pp. 2200.
5. Romano, J.M., Parker, J.C. and Ford, Q.B., (1997),"Application opportunities for nanoparticles made from condensation of physical vapors," Adv. Powder Methal. Partic. Mater, 2, pp.12-13.
6. Zhu, H., and Lin, Y. (2007), "A novel one-step chemical method for preparation of copper nanofluids", J Collide & Int. Sci., 277, pp. 100-103.
7. Liu, M., Lin, M.C., Wang C.C. and Tsai, C.Y., (2006), "Enhancement of thermal conductivity with Cu for nanofluids using chemical reduction method," International Journal Heat & Mass Transfer, 49, pp. 3028 -3033.
8. Phuoc, T.X., Chyu, Y. and Soong, M.K., (2007), "Synthesis of Ag-deionised water nanofluids using multi-beam laser ablation in liquids," optics and lasers in engineering, 45 (12), pp.1099-1106.
9. Kim, S.H., Choi, S.R. and Kim, D., (2007), "Thermal conductivity of metal-oxide nanofluids: particle size dependence and effect of laser irradiation. ASME Transactions," 129, pp. 298-307.

10. Kabashin, A. V. and Meunier, F. M., (2007), "Second laser ablation in aqueous solutions: a novel method to synthesize non-toxic metal colloids with controllable size," *Journal. Phys.: Conf. Series*, 59, pp. 354-359.
11. Hong, J., Kim, S. H. and Kim, D., (2007), "Effect of laser irradiation on thermal conductivity of ZnO nanofluids," *Journal Phys.: Conf. Series*, 59, pp. 301-304.
12. Singh, A.K. and Raykar, V.S., (2008), "Microwave synthesis of silver nanofluids with polyvinyl pyrrolidone (PVP) and their transport properties," *colloid and polymer science*, Accepted for publication.
13. Zenghu, H., (2008), "Nanofluids with Enhanced Thermal Transport Properties," Ph.D. (Thesis report), pp. 18-26.
14. Das, S. K., Choi, S.U.S., Wenhua, Y. and Pradeep, T., (2007), "Nanofluids: science and technology," Wiley interscience, pp. 1-32.
15. Lee, S. and Choi, S. U. S., (1996), "Applications of metallic nanoparticle suspensions in advanced cooling systems," In *Recent Advances in Solids/Structures and Applications of Metallic Materials*.
16. Lee, S. and Choi, S. U. S., (1996), "Nanofluids: science and technology," Wiley interscience, pp. 1-32.
17. Chien, H.T., Tsai, C.I., Chen, P. H. and Chen, P.Y., (2003), "Improvement on thermal performance of a disk-shaped miniature heat pipe with nanofluid," *Proc. International Conference on Electronics Packaging Technology 2003*, IEEE, Piscatway, National Journal, pp. 389-39 .
18. Tzeng, S.C., Lin, C.W. and Huang, K. D., (2005), "Heat transfer enhancement of nanofluids in rotary blade coupling of four wheel drive vehicles," *Acta Mech.*, 179, pp. 11-23.
19. Xuan, Y. and Li., Q., (2000), "Heat transfer enhancement of nanofluids," *International Journal, Heat fluid flow*, 21, pp. 58-64.
20. Choi, S. U. S., Yu., W. and Drobnik, J., (2007), "Temperature and concentration dependence of effective thermal conductivities of alumina-oil based nanofluids," presented at the ECI Conference on "Nanofluids: Fundamental and Application Copper Mountain," Sept 16-20.
21. Kim, S. M., Kim, K.M. and You, J. H., (2003), "Effect of nanoparticles on critical heat flux of water in pool boiling of heat transfer," *Appl. Phys. Lett.*, 83, pp. 3374-3376.
22. Kim, S. J., Bang, I. C., Buongiorno, J. and Hu, L.W., (2006), "Effects of nanoparticles deposition on surface wettability influencing boiling heat transfer in nanofluids," *Appl. Phys Lett.*, 89, pp.153-107.
23. Que, Zhang, Q., J. and Zhang, Z., (1997), "Synthesis, structure and lubricating properties of dialkyldithiophosphate-modified Mo-S compound nanoclusters," 209, pp.8-12.

24. Jordan, A., Scholz, R., Wust, P., Fahling, H. and Felix, R, (1999), "Magnetic fluid hyperthermia (MFH): cancer treatment with ac magnetic field induced excitation of biocompatible super paramagnetic nanoparticles," *J. Magn. Mater*, 201, pp.413-419.
25. Granqvist, C.G, and Buhrman, R.A., (1976), "Ultra-fine metal particles," *Journal Appl. Physics*. 47, pp. 2200.
26. Ravnik, J., Skerget, L. and Hribersek, M., (2010), "Analysis of three-dimensional natural convection of nanofluids by BEM," *Engineering analysis with boundry elements methods*, 34, pp. 1018-1030.
27. AbuNada, E., (2009), "Effects of inclination angle on natural convection in enclosures filled with cu water nanofluid," *Journal Heat Fluid Flow*, 30, pp. 669–78.
28. Wang, X., Xu, and Choi, S.U.S., (1999), "Thermal conductivity of nanoparticle–fluid Mixture," *Journal Thermophysics Heat Transfer*, 13, pp.474–480.
29. Ravikanth., Vajjha, S., Debendra, K. and Das, S.K., (2009), "Experimental determination of Thermal Conductivity of three Nanofluids and Development of New Correlations," *International journal of heat and mass transfer*, 52, pp. 4675- 4682.
30. Eastman, J.A., Choi, S.U.S., Li, S., Yu, W. and Thompson, L.J., (2001), "Anomalously increased effective thermal conductivities of ethylene glycol-based nanofluids containing copper nanoparticles," *Application Physics Lett.*, 78 (6), pp. 718–720.
31. Murshed, S.M.S., Leong, K.C. and Yang, C. (2008), "Investigation of thermal conductivity and viscosity of nanofluids," *International Journal of Thermal Science*, 47, pp. 456- 586.
32. Murshed, S.M.S., Leong, K.C., Yang, C. (2009), "A combined model for the effective thermal conductivity of nanofluids," *Applied Thermal Engineering*, 29, pp. 2477-2483.
33. Xue, Q. and Wen, M.X., (2005), "A model of thermal conductivity of nanofluids with interfacial shells," *Materials Chemistry and Physics*, 90, pp. 298–301.
34. Tavman, (2008), "Experimental Investigation of Viscosity and Thermal Conductivity of Suspension Containing Nanosized Ceramic Particles," *International Scientific Journal*, 34: pp. 99-104.
35. Duan, F., Dingtian, K. and Alexandru, C., (2011), "Viscosity affected by nanoparticle aggressions in Al₂O₃-water nanofluids," *Nanoscale research letters a Springer open journal*, 6, pp. 248.
36. Kleinstreuer, C. and Feng, Y., (2011), "Experimental and theoretical studies of nanofluid thermal conductivity enhancement: a review," *Nanoscale research letters a Springer open journal*, 6, pp. 229.
37. Madhusree, K. and Dey, T.K., (2010), "Viscosity of alumina nanoparticles dispersed in car engine coolant," *Experimental thermal and fluid science journal*, 34, pp. 677- 683.

CHAPTER - 3

EXPERIMENTAL WORK

Nanofluids are multicomponent systems, and the morphology and orientation of the dispersed solids is complex. Nanoparticles are used as additives to modify heat transfer fluids to improve their performance. Before testing of nanofluids for heat transfer, firstly, prepare it and then characterize it. All the thermo physical properties are estimated and then calculate its heat transfer coefficient to know its thermal properties.

3.1 Thermophysical properties

To investigate the effect of the use of nanofluids on the performance of commercial heat transfer, thermophysical properties can be measured such as thermal conductivity, and viscosity. Thermal conductivity can be measured by a thermal conductivity apparatus and then calculated by equation 3.1:

$$k = \frac{Q \Delta x}{A(T_2 - T_1)} \quad (3.1)$$

Viscosity measurements show a dependence on the kind of the nanofluid. So, viscosity of nanofluid can be measured by Ubbelohde viscometer and calculated by equation 3.2:

$$\frac{\mu(\text{fluid})}{\mu(\text{water})} = \frac{t(\text{fluid}) \times \rho(\text{fluid})}{t(\text{water}) \times \rho(\text{water})} \quad (3.2)$$

By this all the thermo-physical properties can be calculated and then observe the change in the properties of nanofluids as compared with base fluids. Nanoparticles are very small, nanometer-sized particles which are stable colloidal suspensions in common base fluids such as water, oil, ethylene-glycol mixtures (antifreeze), polymer solutions, etc. To measure its thermo physical properties various equipments are used such as thermal property analyzer are used to measure thermal conductivity and volumetric heat capacity, and Ubbelohde viscometer as used to measure viscosity.

3.2 Equipment and Instruments used

3.2.1 Ultra Sonicator

Sonication is the act of applying sound (usually ultrasound) energy to agitate particles in a sample, for various purposes. In the laboratory, it is usually applied using an ultrasonic bath known as a

sonicator. Sonication can be used to speed dissolution, by breaking intermolecular interactions. It is especially useful when it is not possible to stir the sample. Sonication is commonly used in nanotechnology for evenly dispersing nanoparticles in liquids.



Figure No. 3.1: Ultra sonicator

Specifications of Ultra Sonicator

Heating and Cleaning

Knob for controlling heating = 1 and,

Knob for controlling Cleaning (ultrasonication) = 1

Heating temperatures range= 0°C to 80°C

Size: width = 10 inch

Length = 8 inch

Height = 8inch

Manufacturing Product: Altra Sonics India,

3/52, Parleshwar Society, M.G. Road Vile Parla (E)

Mumbai 400057

3.2.2 Thermal Property Analyzer

The KD2 Pro is a hand held device used to measure thermal properties. It consists of handheld controller and sensors that can be inserted into the medium. The single needle sensors measure thermal conductivity and resistivity; while the dual needle sensor also measures volumetric specific heat capacity and diffusivity. It has been designed for ease of use and maximum functionality.

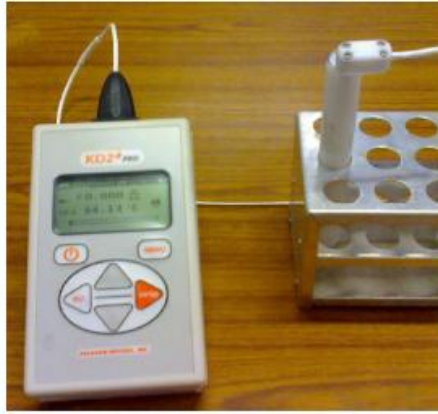

Figure No. 3.2: Thermal analyzer (KD2 Pro)

Specifications

Operating environment:

Controller: 0 to 50 °C

Sensors: -50 to +150 °C

Power: 4 AA cells

Battery life: At least 500 readings in constant use or 3 years with no use (battery drain in sleep mode < 50 uA)

Case size: 15.5 cm x 9.5 cm x 3.5 cm

Display: 3 cm x 6 cm, 128 x 64 pixel graphics LCD

Keypad: 6 key, sealed membranes

Data storage: 4095 measurements in flash memory (both raw and processed data are stored for download)

Interface: 9-pin serial

Read modes: Manual and Auto Read

3.2.3 Sensors: KS-1 Single Needle

The small (60 mm long, 1.3 mm diameter) single needle KS-1 sensor measures thermal conductivity and thermal resistivity. It is designed primarily for liquid samples and insulating materials (thermal conductivity < 0.1 W/ (m.K)). The KS-1 sensor applies a very small amount of heat to the needle which helps to prevent free convection in liquid samples. However, the small size of the needle and typically short heating time make the KS-1 a poor choice for granular samples such as soil and powders where contact resistance can be an important source of error. In insulating materials, the errors from contact resistance become negligible making the KS-1 sensor a good choice.



Figure No. 3.3: KS-1 Single Needle

Specifications

Size: 1.3mm diameter x 60mm long

Range: 0.02 to 2.00W/ (m.K) (thermal conductivity)

50 to 5000 °C cm/W (thermal resistivity)

Accuracy (Conductivity): $\pm 5\%$ from 0.2. 2 W/ (m.K)

± 0.01 W/ (m.K) from 0.02 -0.2 W/ (m.K)

Cable length: 0.8 m

3.2.4 TR-1 Single Needle

The large (100 mm long, 2.4 mm diameter) single needle TR-1 sensor measures thermal conductivity and thermal resistivity. It is designed primarily for soil, concrete, rock, and other granular or solid materials. The relatively large diameter and typically longer heating time of the TR-1 sensor minimize errors from contact resistance in granular samples or solid samples with pilot holes. The TR-1 needle heats the sample significantly more than the KS-1 sensor, which allows it to measure higher thermal conductivity samples, but means that you not measure liquid samples with the TR-1 sensor. The large diameter of the TR-1 is more robust than the KS-1, meaning that it is less likely to be damaged by normal usage conditions in soil or other solid materials. Additionally, the dimensions of the TR-1 sensor conform to the specifications for the Lab Probe called out by the IEEE 442-03 Guide for soil Thermal resistivity measurements.

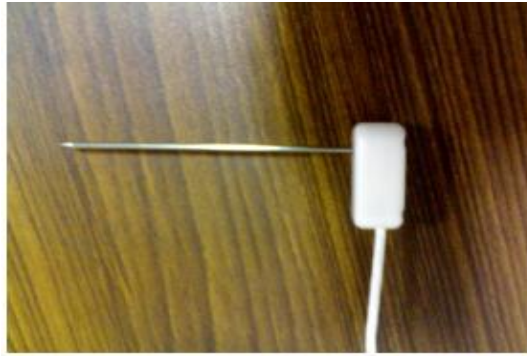

Figure No 3.4: TR-1 Sensor Needle

Specifications

Size: 2.4 mm diameter x 100 mm long

Range: 0.10 to 4.00W/m.K (Thermal conductivity)

25 to 1000 °C cm /W (Thermal resistivity)

Accuracy (conductivity): $\pm 10\%$ from 0.2. 4W/ (m.K)

± 0.02 W/ (m.K) from 0.1.0.2 W/ (m.K)

Cable length: 0.8 m

3.2.5 SH-1 Dual Needle

The dual needle SH-1 sensor measures volumetric heat capacity, thermal diffusivity, thermal conductivity, and thermal resistivity. The SH-1 is compatible with most solid and granular materials, but should not be used in liquids due to the large heat pulse and possible resulting free convection in liquid samples.

Specifications

Size: 1.3 mm diameter x 30 mm long, 6 mm spacing

Range: 0.02 to 2.00W/ (m.K) (thermal conductivity)

50 to 5000 °C cm/W (thermal resistivity)

0.1 to 1 mm²/s (diffusivity)

0.5 to 4 mJ/ (m³K) (volumetric specific heat)

Accuracy: (conductivity) $\pm 10\%$ from 0.2-2W/ (m.K)

± 0.01 W/ (m.K) from 0.02 -0.2 W/ (m.K)

(Diffusivity) $\pm 10\%$ at conductivities above 0.1 W/ (m.K)

(Volumetric Specific Heat) $\pm 10\%$ at conductivities above 0.1 W/ (m.K)

Cable length: 0.8 m

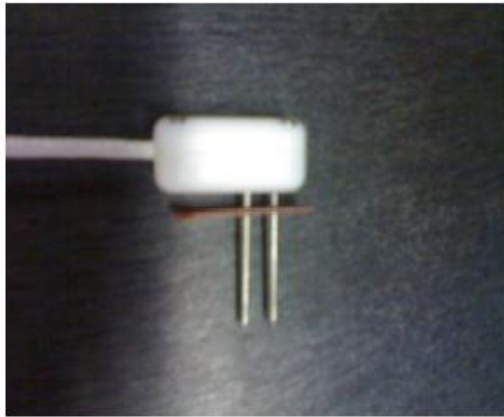

Figure No. 3.5: SH-1 Dual Needle

3.3 Ubbelohde Viscometer

Ubbelohde viscometers are used for the measurement of liquid fluid viscosity. These device also are known as glass capillary viscometers, which U- shaped glass tube held vertically in a controlled temperature bath. The Ubbelohde viscometers are used for the measurement of kinematic viscosity of Newtonian liquids that are sufficiently transparent to enable the meniscus of the liquid to be observed during measurement. In an Ubbelohde viscometer the time that the liquid level takes to flow between two ring marks indicates the viscosity of the test fluid. In Ubbelohde viscometers time is measured using stopwatches. The time taken for the level of the liquid to pass between these marks is proportional to the kinematic viscosity. Most commercial units are provided with a conversion factor, or can be calibrated by a fluid of known properties. The viscosity of the test liquid is determined by measuring the time it takes for the sample, whose volume is defined by two ring-shaped marks to flow laminarily through a capillary under the influence of gravity. Hence, the friction within the liquid with high viscosity needs more time to pass the distance between the two measuring marks within the capillary tube. In accurate measurements these time is mostly measured by stopwatches.



Figure No. 3.6: Ubbelohde -viscometer with temperature bath

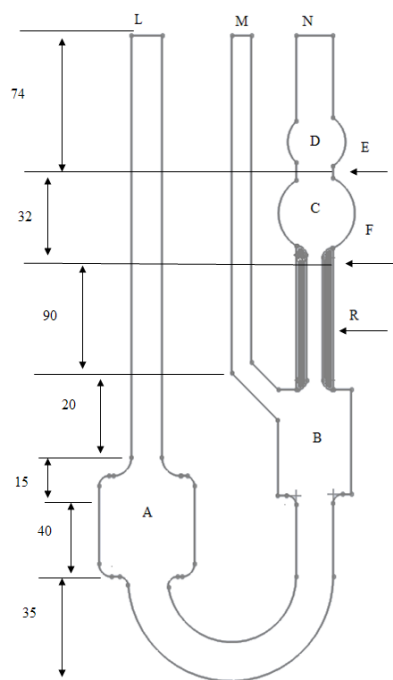

Figure No. 3.7: Ubbelohde-viscometer

Where - L= Filling tube, A= Filling mark, M= Ventilation tube, N= Capillary tube, D=Upper reservoir, C= Timing bulb, E and F= Measuring mark, R= Inner capillary, B= Suspended level tube. The time required for the test the liquid to flow through a capillary of a known diameter of a certain factor between two marked points is measured. By multiplying the time taken by the factor of the viscometer, the kinematic viscosity is obtained. It can be calculated as equation 2.

3.4 Specific gravity Bottle

Specific gravity bottle is used to measure the density of any fluid. Relative density, or specific gravity is the ratio of the density (mass of a unit volume) of a substance to the density of a given reference material. Specific gravity usually means relative density with respect to water. Relative density (RD) or specific gravity (SG) is a dimensionless quantity, as it is the ratio of either densities or weights:

$$RD = \frac{\rho(\text{Substance})}{\rho(\text{reference})}$$



Figure No 3.8: Specific gravity bottle

A specific gravity bottle holds a known volume of liquid at a specified temperature. The bottle is weighed, filled with a liquid whose specific gravity is to be found and then again weighed. The difference in weights is divided by the weight of an equal volume of water to give the specific gravity of the liquid. Note that since water has a density of 1 g/cm^3 , the specific gravity is the same as the density of the material measured in g/cm^3 .

CHAPTER - 4

MATERIALS AND METHODOLOGY

4.1 Introduction

The main aim of this thesis is to prepare nanofluids with Al_2O_3 nanoparticles and distilled water as base fluid for improving the heat transfer characteristics of the fluid. These analyses are performed by measuring all thermo physical properties like thermal conductivity, density and viscosity at different temperatures for the different volume concentrations of nanofluids.

4.2 Materials Required

4.2.1 Materials used for preparing Nanofluids

- Nanoparticles - Al_2O_3 (Average size : 45 nm)
- Distilled water

4.3 Methodology

4.3.1 Preparation of nanofluids

Aluminium oxide (Al_2O_3) nanoparticles are purchased from M/s. Alpha Aesar, A Johnson Matthey Chemicals India Pvt Ltd., Hyderabad. The size of nanoparticles is 45 nm as it was mentioned by the company. For its characterization, it can be tested under SEM in R&D of Thapar University, Patiala but due to some problem in SEM results are not satisfactory. Nanofluids are prepared by two step process. The resulting nanoparticles are then dispersed into the base fluid i.e. distilled water. Make the volume concentration of 1 % and 0.5 % Al_2O_3 by mixing nanoparticles in 100 ml of distilled water. To make the nanoparticles more stable and remain more dispersed in water, ultra sonicator is used. Sonication had done for 4-5 hours before testing any thermo physical property of the nanofluids. By this nanoparticles become more evenly dispersed in distilled water.

4.3.2 Thermo physical Properties Measurement

For the measurement of Thermal conductivity, KD2 Pro is used. Different sensors are used for the measurement of these properties. As nanofluids are relatively low viscosity fluid, so KS-1 sensor is used to measure the thermal conductivity. These properties can be measured at various ranges of

temperatures such as from 30 °C to 90 °C. Nanofluids get heated by hot plate and wait till the steady state achieved at particular temperature. After attaining the steady state, dipped the sensor in the bottle and on the KD2 Pro. It takes 1 minute for thermal conductivity. After this note the readings at that particular temperature which shows on the screen. Same experiment is repeated for the different volume concentrations of nanofluids i.e. for 1 %, and 0.5 % at different temperature.

For the measurement of density of nanofluids, specific gravity bottle method is used. Firstly, weigh the specific gravity bottle then fill with the distilled water. Weigh the bottle filled with water at different temperature ranges from 30 °C to 70 °C. Then, the filled bottle with nanofluids sample was weighed again at different temperatures. To calculate the specific gravity, take the ratio of the net weight of the nanofluid and distilled water. Distilled water is used as a reference because water is used as a base fluid for the preparation of nanofluids.

For the measurement of viscosity of nanofluids, Ubbelohde viscometer is used. There are two bulbs such as one is at lower section on one side and other bulb is at upper side of another side. Fill the lower bulb with water and then water is drawn into the upper bulb by suction, and then allowed to flow down through the capillary into the lower bulb. The time taken for the water to pass between the two marks of viscometer noted down. This is done at various temperature ranges i.e. 30° C to 70 °C. Viscometer put in the water bath and then, maintains the steady state at 30 °C, 40 °C, 50 °C, 60 °C, and 70 °C. Note down the time taken for fluid to pass between the two marks after attaining the steady state. Firstly, it was done for distilled water as distilled water is used as a base fluid for preparing nanofluids. Then, same method is done for the other samples i.e. (Al₂O₃) 1 % and 0.5 %. Volume concentrations of nanofluids and noted down the time at different temperatures. Then, calculate the dynamic viscosity by dividing it by density.

At last, the measured properties such as thermal conductivity and viscosity have compared with the various theoretical different models.

CHAPTER – 5

RESULTS AND DISCUSSIONS

In this chapter discuss all the results which get from the experiments like thermal conductivity measurement, viscosity measurement, and density measurement. Various experiments were performed during thesis work with the help of various apparatus and techniques as mentioned in previous chapter.

5.1 Thermal conductivity measurement

Thermal conductivity can be measured by thermal property analyzer i.e. KD2 Pro by using KS-1 sensor needle as this needle is preferred for low viscosity fluids. It is measured at different ranges of temperature such as from 25°C to 90°C for the different concentration of nanoparticles such as 1 % and 0.5 % and data calculated by experiment is mentioned in Table 5.1 and 5.2.

5.1.1 Thermal conductivity measurement at different temperatures by KD2 Pro

Table 5.1: Values of Thermal conductivity by KD2 Pro for 1% Al₂O₃ nanofluids by Volume

S. No	Temperature, °C	Thermal conductivity (W/(m.K) 1 % Al ₂ O ₃)
1	27.89	0.632
2	37.05	0.663
3	48.57	0.712
4	59.20	0.754
5	68.90	0.880
6	79.60	1.002
7	88.56	1.109
8	95.44	1.518

Table 5.2: Values of Thermal conductivity by KD2 Pro for 0.5% Al₂O₃ nanofluids by Volume

S. No	Temperature, °C	Thermal conductivity (W/(m.K) 0.5 % Al ₂ O ₃)
1	27.17	0.621
2	36.71	0.630
3	46.33	0.693
4	57.59	0.746
5	67.88	0.836
6	78.56	0.978
7	89.50	1.101
8	93.46	1.342

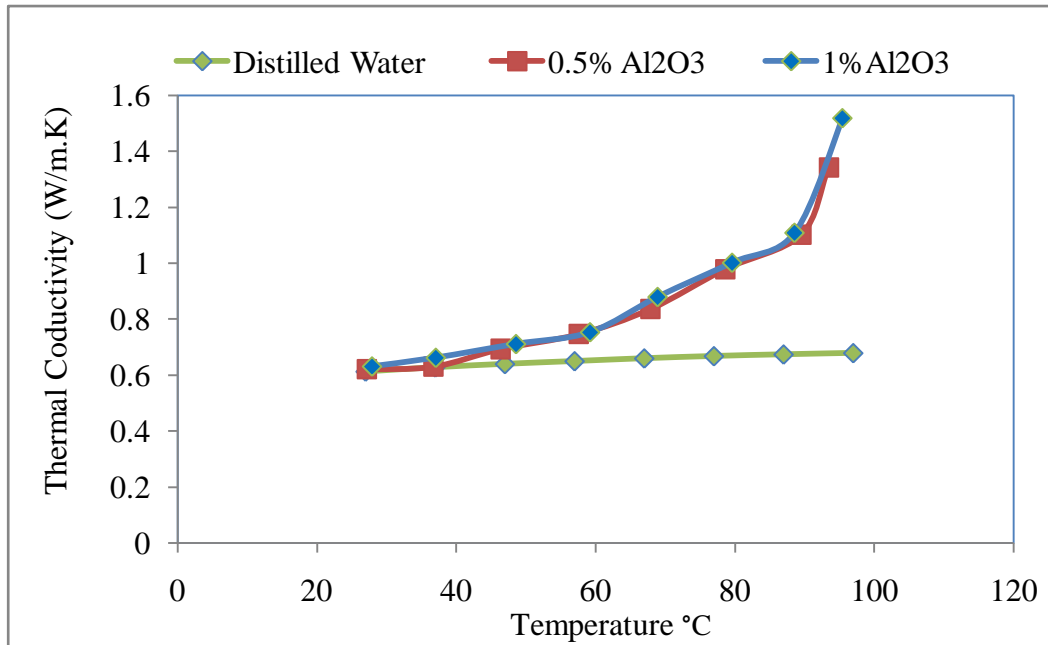

Figure No.5.1: Comparison of Thermal Conductivity for 1% and 0.5% Al₂O₃ nanofluids by volume.

From figure 5.1, it can be concluded that thermal conductivity of nanofluids has increased with increase in temperature. As well as with increase in concentrations of nanoparticles, thermal conductivity of nanofluids gets increased. It has been observed that 1% to 4 % increase in thermal conductivity at 30°C for the 0.5% and 1% water-Al₂O₃ nanofluids. When the temperature is increased approximately up to 90°C, thermal conductivity get enhanced by 43 % to 46 % for the 0.5% and 1% water-Al₂O₃ nanofluids. According to the graph, effect of temperature on thermal conductivity enhancement is even more than water and it rises from 1% to 43% (for 0.5% particle concentration), and 3% to 46% (for 1% particle concentration). The measurement indicates that particle concentrations and temperature is an important parameter for thermal conductivity.

5.1.2 Thermal conductivity at different temperatures from Maxwell model

Thermal conductivity of nanofluids can be estimated by the relation provided by Maxwell is as follows:

$$\frac{k_{\text{eff}}}{k_m} = 1 + \frac{3 * (\alpha - 1) * v}{(\alpha + 2) - (\alpha - 1) * v} \quad (5.1)$$

k_{eff} = Thermal Conductivity of solid / liquid (Al₂O₃)

k_m = Thermal Conductivity of base fluid (DIW)

k_2 = Thermal Conductivity of nanoparticle, v = Particle volume fractions (1% and 0.5%)

$$\alpha = \frac{k_2}{k_m}$$

Table 5.3: Values of Thermal conductivity at different temperature for Maxwell Model

S. No.	Temperature °C	Thermal conductivity (W/(m.K) Base fluid Distilled Water	K_{eff}	
			$v = 1\%$	$v = 0.5\%$
1	27	0.613	0.630624	0.62177
2	37	0.628	0.646032	0.636973
3	47	0.640	0.658358	0.649135
4	57	0.650	0.688629	0.659127
5	67	0.660	0.678899	0.669405
6	77	0.668	0.687115	0.677512
7	87	0.674	0.69327	0.683593
8	97	0.679	0.698412	0.68866

5.1.3 Thermal conductivity at different temperatures from Hamilton Crosser Model

The other model used to calculate thermal conductivity is proposed by Hamilton Crosser is as follows:

$$\frac{k_{eff}}{k_m} = \frac{\alpha + (n-1) - (n-1)(1-\alpha)*v}{\alpha + (n-1) + (1-\alpha)*v} \quad (5.2)$$

k_{eff} = Thermal Conductivity of solid / liquid (Al_2O_3)

k_m = Thermal Conductivity of base fluid (DIW)

k_2 = Thermal Conductivity of nanoparticle, v = Particle volume fractions (1% and 0.5%)

n = For spherical particles (data)

$$\alpha = \frac{k_2}{k_m}$$

Table 5.4: Values of Thermal conductivity at different temperatures for Hamilton Crosser Model

S. No.	Temperature °C	Thermal conductivity (W/(m.K) Distilled water (km)	K _{eff}	
			v = 1%	v = 0.5%
1	27	0.613	0.630620	0.62177
2	37	0.628	0.64603	0.636973
3	47	0.640	0.658358	0.649135
4	57	0.650	0.668629	0.659127
5	67	0.660	0.678899	0.669405
6	77	0.668	0.687115	0.677512
7	87	0.674	0.693277	0.683593
8	97	0.679	0.698412	0.68866

5.1.4 Thermal conductivity at different temperatures from Jeffery Model

Another model which can also be used to calculate the thermal conductivity is given by Jeffery is as follows:

$$\frac{k_{\text{eff}}}{k_m} = 1 + 3\beta v + \left(3\beta^2 + \frac{3\beta^2}{4} + \frac{9\beta^3}{16} \frac{\alpha+2}{2\alpha+3} + \dots \right) \times v^2 \quad (5.3)$$

K_{eff} = Thermal Conductivity of solid / liquid (Al₂O₃)

k_m = Thermal Conductivity of base fluid (DIW)

k₂ = (Thermal conductivity of Al₂O₃ nanoparticle source from data),

v = Particle volume fractions (1% and 0.5%)

$$\alpha = \frac{k_2}{k_m}, \beta = (\alpha-1) / (\alpha+2)$$

Table 5.5: Values of Thermal conductivity at different temperature for Jeffery Model

S. No.	Temperature °C	Thermal conductivity (W/(m.K) Distilled water (km)	K _{eff}	
			v = 1%	v = 0.5%
1	27	0.613	0.630678	0.621784
2	37	0.628	0.646088	0.636987
3	47	0.640	0.658415	0.649115
4	57	0.650	0.668686	0.659285
5	67	0.660	0.67895	0.66942
6	77	0.668	0.687174	0.677527
7	87	0.674	0.693337	0.683608
8	97	0.679	0.698472	0.688675

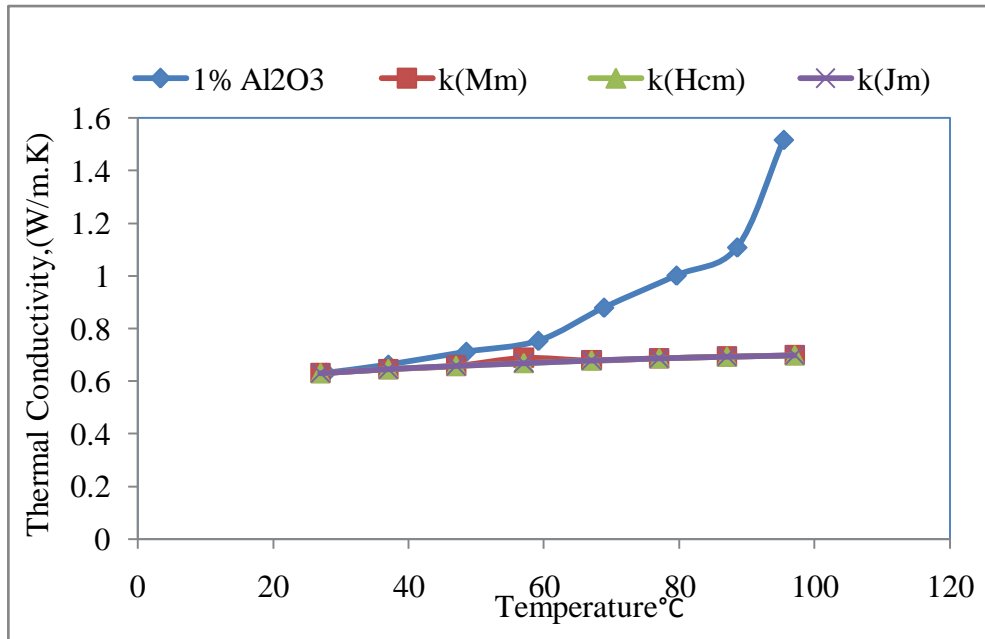

Figure No. 5.2: Comparisons of experimental values of thermal conductivity with various models for 1% Al₂O₃ nanofluids by volume

From the above figure 5.2, it can be concluded that experimental value show great enhancement in thermal conductivity of 1% Al₂O₃ nanofluids by volume when compared with the model values while all the values of models are nearly same.

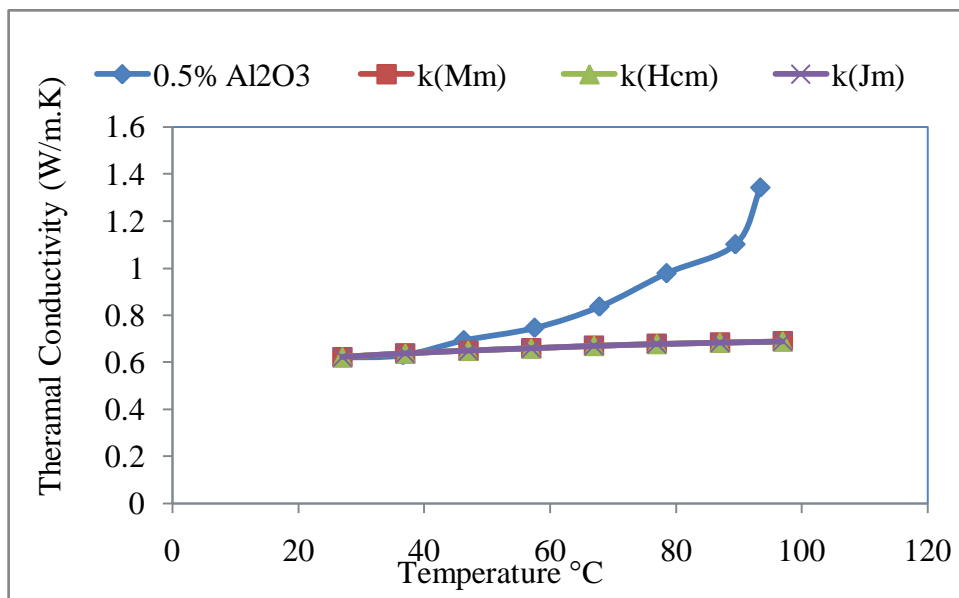

Figure No. 5.3: Comparisons of experimental values of thermal conductivity with various models for 0.5% Al₂O₃ nanofluids by volume

From the above figure 5.3, it can be concluded that experimental value show great enhancement in thermal conductivity of 1% Al₂O₃ nanofluids by volume when compared with the model values while all the values of models are nearly same.

Symbols above in the figure 5.2 and 5.3: k(Mm)–Thermal conductivity of Maxwell Model, k(Hcm)– Thermal conductivity of Hamilton Crosser Model, k(Jm)– Thermal conductivity of Jeffery Model, k(KD2 Pro)– Thermal conductivity by KD2 pro.

5.2 Viscosity measurement

The viscosity can be measured by Ubbelohde viscometer at various ranges of temperatures such as 30 °C, 40 °C, 50 °C, 60 °C, and 70 °C. It can be measured for distilled water, 1 % and 0.5% volume concentrations of Al₂O₃ nanofluids. The experimental values which are drawn by the experiment are mentioned in table 5.6, 5.7, 5.8 and 5.9.

Table 5.6: Time taken for distilled water by Ubbelohde viscometer

Distilled water					
Time, seconds					
S. No	30 °C	40 °C	50 °C	60 °C	70 °C
1	96sec	80sec	68sec	119sec	112sec
2	96sec	80sec	68sec	119sec	113sec
3	95sec	81sec	69sec	119sec	112sec

Table 5.7: Time taken for 1% Al₂O₃ nanofluids by Ubbelohde viscometer

Al₂O₃ = 1%					
Time, seconds					
S. No	30 °C	40 °C	50 °C	60 °C	70 °C
1	95sec	85sec	68sec	62sec	114sec
2	96sec	85sec	68sec	61sec	113sec
3	95sec	83sec	66sec	62sec	114sec

Table 5.8: Time taken for 0.5% Al₂O₃ nanofluids by Ubbelohde viscometer

Al₂O₃ = 0.5%					
Time, seconds					
S. No	30 °C	40 °C	50 °C	60 °C	70 °C
1	98sec	80sec	68sec	60sec	51sec
2	97sec	81sec	68sec	59sec	52sec
3	95sec	81sec	67sec	58sec	51sec

Table 5.9: Viscosity at different temperature for 1 %, 0.5 % Al₂O₃ nanofluids

S. No.	Temperature, °C	Viscosity, (cP) (1%)	Viscosity, (cP) (0.5%)
1	30	1.03042	0.9566
2	40	0.88714	0.7968
3	50	0.67560	0.650914
4	60	0.594146	0.562716
5	70	0.49085	0.468566

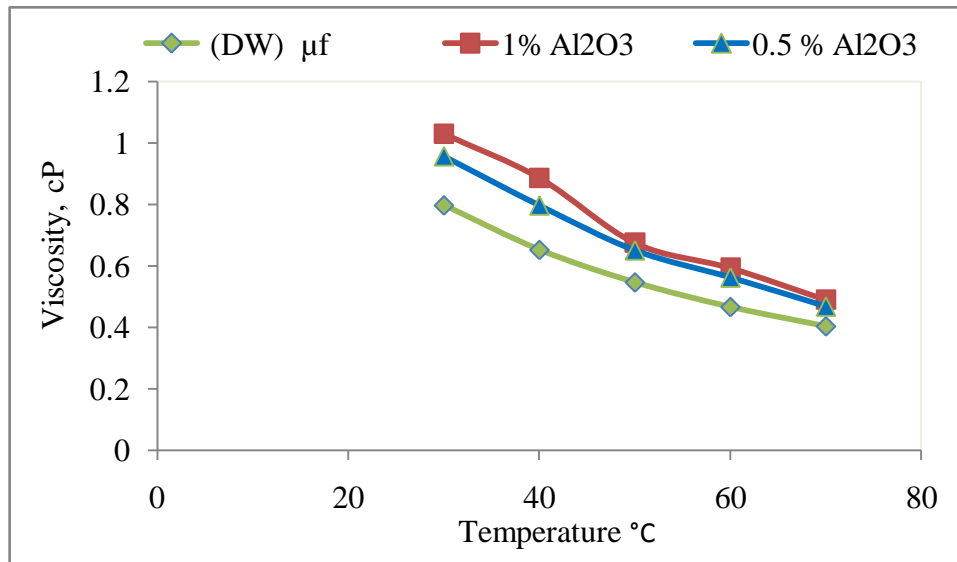

Figure No. 5.4 : Variation of Viscosity of nanofluid (Al₂O₃) with temperature for 1% and 0.5% by volume

From the above data and figure 5.4, it seems that viscosity is gradually decreased with increase in temperature as well as with decrease in nanoparticle volume fraction. As compared with the viscosity of nanofluids with water, it shows that nanofluids become more viscous than water. And as further nanoparticle concentration increases, viscosity is increased.

5.2.1 Viscosity from Einstein Model

Viscosity of nanofluids can be calculated by the relation given by Einstein is as follows:

$$\mu_{nf} = \mu_f \times (1 + 2.5\phi + 6.5 \phi^2) \quad (5.4)$$

Where, μ_{nf} = Viscosity of nanofluid (Al₂O₃)

μ_f = Viscosity of base fluid (DIW), ϕ = Particle of Volume fraction (1%) and (0.5%)

Table 5.10: Values of viscosity from Einstein Model for 1% and 0.5% volume concentration of Al₂O₃ water nanofluids

S. No	Temperature °C	Viscosity of base fluid (DW) μ_f	Viscosity of nanofluids	
			$\emptyset = 0.01$	$\emptyset = 0.005$
1	30	0.798	0.818469	0.808105
2	40	0.653	0.669749	0.661269
3	50	0.547	0.561031	0.553926
4	60	0.467	0.478979	0.472913
5	70	0.404	0.414363	0.409116

5.2.2 Viscosity from Brinkman Model

Other model which is used to calculate viscosity is given by Brinkman which is as follows:

$$\mu_{nf} = \mu_f \times \left(\frac{1}{(1-\emptyset)^{2.5}} \right) \quad (5.5)$$

Where, μ_{nf} = Viscosity of nanofluid (Al₂O₃)

μ_f = Viscosity of base fluid (DIW)

\emptyset = Particle of Volume fraction (1%) and (0.5%)

Table 5.11: Values of viscosity from Brinkman Model for 1% and 0.5% volume concentration of Al₂O₃ water nanofluid

S. No	Temperature °C	Viscosity of base fluid (DW) μ_f	Viscosity of nanofluids	
			$\emptyset = 0.01$	$\emptyset = 0.005$
1	30	0.798	0.818304	0.808063
2	40	0.653	0.669615	0.661234
3	50	0.547	0.560918	0.553898
4	60	0.467	0.478882	0.472889
5	70	0.404	0.414279	0.409095

5.2.3 Viscosity from Lundgen Model

Lundgen is also given a model to calculate the viscosity which is as follows:

$$\mu_{nf} = \mu_f \times (1 + 2.5\phi + 6.25 \phi^2 + 0 \phi^3) \quad (5.5)$$

Where, μ_{nf} = Viscosity of nanofluid (Al_2O_3)

μ_f = Viscosity of base fluid (DIW)

ϕ = Particle of Volume fraction (1%) and (0.5%)

Table 5.12: Values of viscosity from Lundgen Model for 1% and 0.5% volume concentration of Al_2O_3 water nanofluid

S. No	Temperature °C	Viscosity of base fluid (DW) μ_f	Viscosity of nanofluids	
			$\phi = 0.01$	$\phi = 0.005$
1	30	0.798	0.818449	0.8081
2	40	0.653	0.669733	0.661265
3	50	0.547	0.561017	0.553923
4	60	0.467	0.478967	0.47291
5	70	0.404	0.414353	0.409113

5.2.4 Viscosity from Kerieger and Dougherty Model

To calculate the viscosity of nanofluids Kerieger and Dougherty is given a relation which is as follows:

$$\eta_{nff} = \eta_f \times \left(1 - \frac{\phi_p}{\phi_m}\right)^{-\eta} \times (\phi_m) \quad (5.6)$$

Where, η_{nff} = Viscosity of nanofluid (Al_2O_3)

η_f = Viscosity of base fluid (DW)

ϕ_p = Particle of Volume fraction (1%) and (0.5%)

ϕ_m = (0.64) Maximum close Packing fraction

$\eta = 2.5$ (Intrinsic Viscosity for hard Spheres)

Table 5.13: Values of viscosity from Kerieger and Dougherty Model for 1% and 0.5% volume concentration of Al₂O₃ – water nanofluid

S. No	Temperature °C	Viscosity of base fluid (DW) μ_f	Viscosity of nanofluids	
			$\phi_p = 0.01$	$\phi_p = 0.005$
1	30	0.798	0.531229	0.520833
2	40	0.653	0.434702	0.426195
3	50	0.547	0.364138	0.357012
4	60	0.467	0.310882	0.304798
5	70	0.404	0.268943	0.263668

5.2.5 Viscosity from Nielsen Model

Viscosity of nanofluids can also be calculated by the relation proposed by Nielsen which is as follows:

$$\eta_{\text{nff}} = \eta_f \times (1 + 1.5 \phi_p) \times e^{\frac{\phi_p}{(1-\phi_m)}} \quad (5.7)$$

Where, η_{nff} = Viscosity of nanofluid (Al₂O₃)

η_f = Viscosity of base fluid (DW)

ϕ_p = Particle of Volume fraction (1%) and (0.5%)

ϕ_m = Maximum close Packing fraction

Table 5.14: Values of viscosity from Nielsen Model for 1% and 0.5% volume concentration of Al₂O₃ – water nanofluid

S. No	Temperature °C	Viscosity of base fluid (DW) μ_f	Viscosity of nanofluids	
			$\phi_p = 0.01$	$\phi_p = 0.005$
1	30	0.798	0.78764	0.815071
2	40	0.653	0.644674	0.66696
3	50	0.547	0.5400256	0.55870
4	60	0.467	0.461045	0.476990
5	70	0.404	0.39884	0.41264

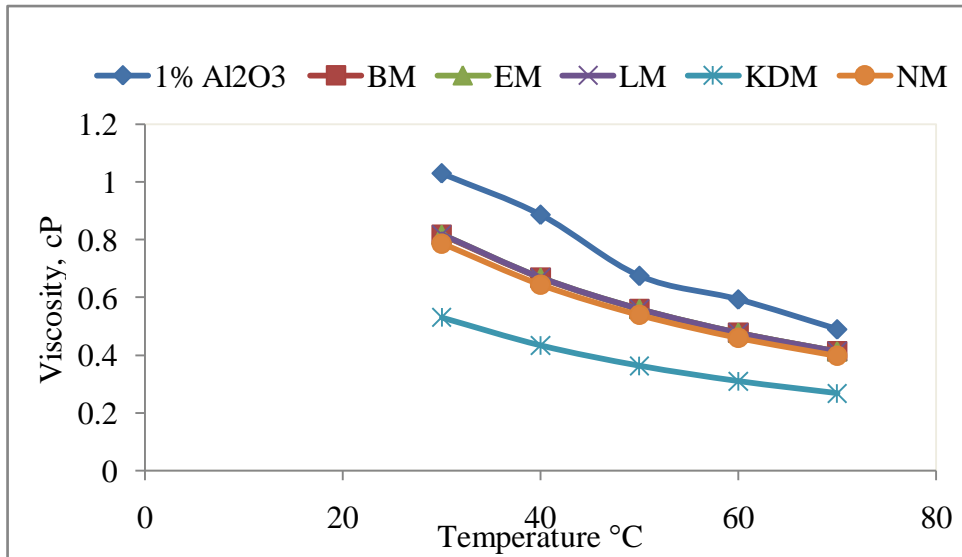

Figure No 5.5: Comparisons of experimental values of viscosity with various models for 1% Al₂O₃ nanofluid by volume

From figure no 5.5, it can be concluded that the viscosity calculated by Ubbelohde viscometer is comparatively high when it was compared with the various models. Except this Kerieger and Dougherty Model, rest of all the models having almost same value of viscosity. It can also be concluded that behavior of experimental value of viscosity is same as by the models. Viscosity is decreased with increase in temperature for 1% Al₂O₃ nanoparticles by volume.

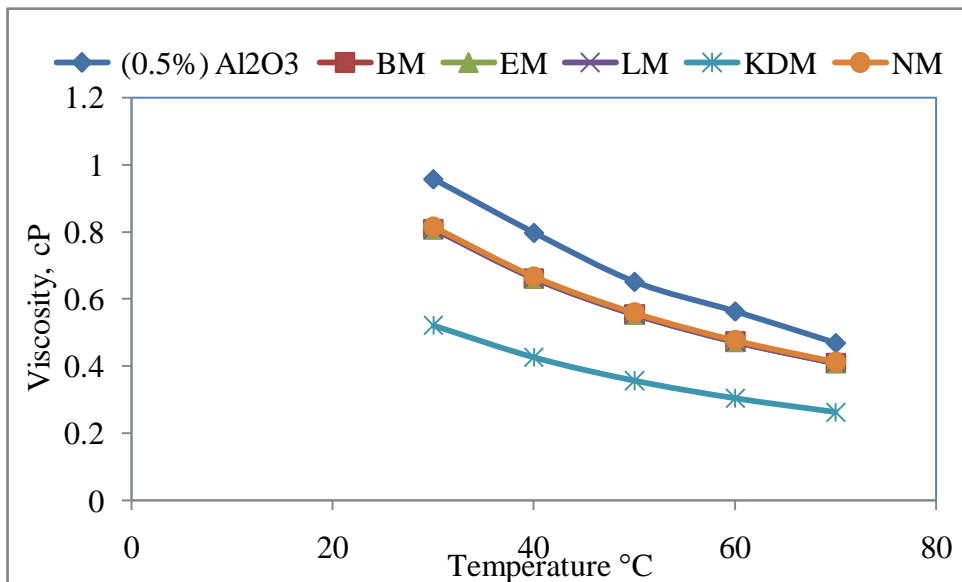

Figure No 5.6: Comparisons of experimental values of viscosity with various models for 0.5% Al₂O₃ nanofluid by volume

From figure no 5.5, it can be concluded that the viscosity calculated by Ubbelohde viscometer is comparatively high when it was compared with the various models. Except this Kerieger and Dougherty Model, rest of all the models having almost same value of viscosity. Kerieger and Dougherty Model show great variation in the values when compared with other models. It can also be concluded that behavior of experimental value of viscosity is same as by the models. Viscosity is decreased with increase in temperature for 0.5% Al₂O₃ nanoparticles by volume.

Symbols used in above figure 5.5 and 5.6: BM- Brinkman Model, EM- Einstein Model, LM- Lundgen Model, KDM- Kerieger and Dougherty Model, NM- Nielsen Model

5.3 Density measurement

Density can be measured by specific gravity bottle at different ranges of temperature such as 30 °C, 40 °C, 50 °C, 60 °C, 70 °C for distilled water and different concentrations of nanofluids i.e. 1%, 0.5%. Since water has a density of 1000 kg/m³, the specific gravity is the same as the density of the material measured in kg/m³. All the experimental data are mentioned in table 5.9 and 5.10. Weight of specific gravity bottle = 9.606 gm.

Table 5.15: Net weight of Distilled water and 1% and 0.5% Al₂O₃ nanofluid

S. No	Temperatures, °C	Distilled water, gm	1% Al ₂ O ₃ nanofluid, gm	0.5 % Al ₂ O ₃ nanofluid, gm
1	30	5.913	6.121gm	5.974 gm
2	40	5.785	6.1 gm	5.955 gm
3	50	5.662	6.072 gm	5.908 gm
4	60	5.685	5.882 gm	5.822 gm
5	70	5.713	5.794 gm	5.782 gm

Table 5.16: Value of density at different temperature for 1% and 0.5% Al₂O₃

S. No	Temperatures, °C	Density(ρ), (kg/m ³) 1% Al ₂ O ₃	Density(ρ), (kg/m ³) 0.5% Al ₂ O ₃	Density (ρ) of Water (kg/m ³)
1	30	1224.2	1194.8	995.7
2	40	1220.0	1191.0	992.2
3	50	1214.4	1181.6	988.1
4	60	1176.4	1164.4	983.2
5	70	1158.8	1156.4	977.8

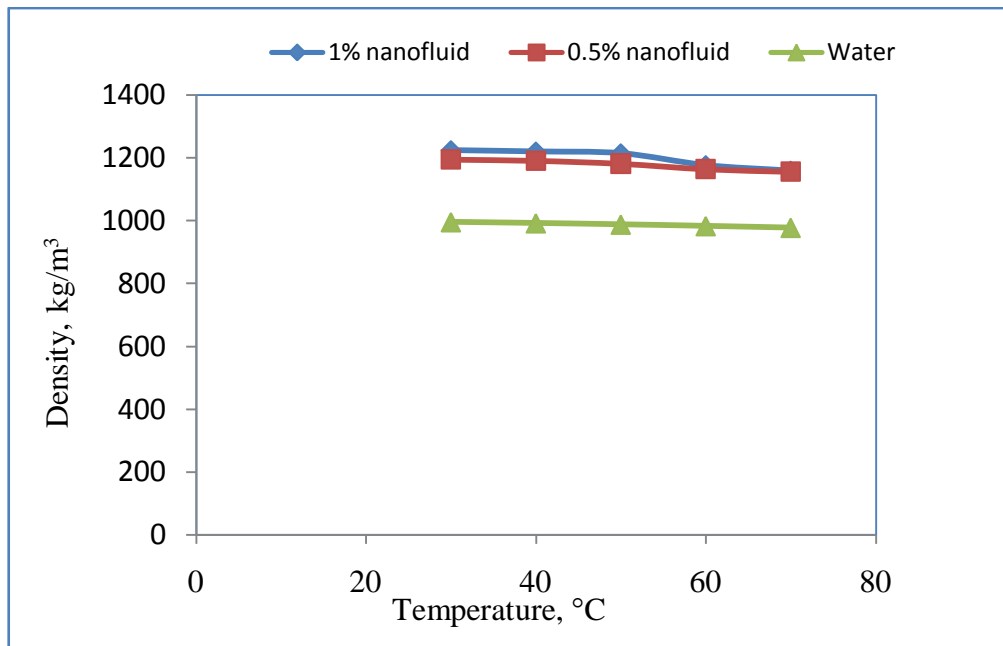

Figure No. 5.7: Variation of Density of Nanofluid (Al_2O_3) at different temperature

Density of 1% and 0.5% Al_2O_3 nanofluids are measured by the experiments. According to figure 5.7, temperature has also impact on the density of nanofluids. Density of nanofluids is decreased with increase in temperature. Further, if nanoparticle volume fraction increases from 0.5% to 1%, density is also increased.

CHAPTER – 6

CONCLUSIONS

All results are concluded on the basis of the experiment performed for measuring the thermophysical properties like thermal conductivity, viscosity and density and further these experimental values are compared with the various theoretical models. This chapter summarizes the conclusion drawn in this report.

1. Nanofluids are dilute colloidal suspensions with nano-sized particles. It can be prepared by dispersing the nanoparticles in base fluid and then put the samples in ultra sonicator to make the nanoparticles more suspended in the fluid and it also increases the stability of nanofluid.
2. The effective thermal conductivity of nanofluids can be measured by thermal property analyzer such as KD2 Pro at different ranges of temperature. The experimental results show that an increase in the enhancement of thermal conductivity of Al_2O_3 – water with increase in temperature. Effect of temperature on thermal conductivity enhancement is even more than water and it rises from 1% to 43% (for 0.5% particle concentration) and 3 % to 46 % (for 1% particle concentration). With increase in particle volume concentration, thermal conductivity of nanofluids also increased.
3. The experimental values of thermal conductivity are quite high as compared with the models value. But the values of all the models are nearly same.
4. Viscosity and density of nanofluids are measured by Ubbelohde viscometer and specific gravity bottle, respectively. From the experimental results, it is observed that nanofluids have higher viscosity and density than the base fluid. Viscosity and density both are decreases with increases in temperature. Viscosity and density increases by increasing the particle volume concentration of nanofluids.
5. The experimental values of viscosity are compared with the models value. But the values of all the models are nearly same except the Kerieger and Dougherty Model. The values from this model are quite less from rest of the model.

CHAPTER – 7

FUTURE RECOMMENDATIONS

This work can be extended to include following areas may be considered for further recommendations:

1. Thermophysical properties can be measured by changing the nanoparticles and its size or by changing the base fluid at different nanoparticle volume fraction.
2. Nanofluids can be used in heat transfer applications to improve the heat dissipation rate in thermal systems.