

**An Optimized CH Selection using GA and Distance Aware Routing Protocol  
for WSN**

*Thesis submitted in partial fulfillment of the requirements for the award of degree  
of*

**Master of Engineering**

in

**Information Security**

*Submitted By*

**Simmi Kansal**

**(Roll No. 801333026)**

Under the supervision of:

**Dr. Shivani Goel**

Assistant Professor

**Ms. Tarunpreet Bhatia**

Lecturer



COMPUTER SCIENCE AND ENGINEERING DEPARTMENT

THAPAR UNIVERSITY

PATIALA – 147004

**July 2015**

## CERTIFICATE

I hereby certify that the work which is being presented in the thesis entitled, "*An Optimized CH Selection using GA and Distance Aware Routing Protocol for WSN*" in partial fulfillment of the requirements for the award of degree of Master of Engineering in *Information Security* submitted in Computer Science and Engineering Department of Thapar University, Patiala, is an authentic record of my own work carried out under the supervision of *Dr. Shivani Goel, Ms. Tarunpreet Bhatia* and refers other researcher's work which are duly listed in the reference section.

The matter presented in the thesis has not been submitted for award of any other degree of this or any other University.

Signature:  
  
(Shivani Kansal)

This is to certify that the above statement made by the candidate is correct and true to the best of my knowledge.

  
(Dr. Shivani Goel)  
Assistant Professor,  
Computer Science and  
Engineering Department  
Countersigned by

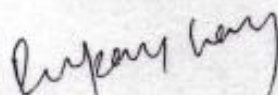
  
(Dr. Deepak Garg)  
Head  
Computer Science and Engineering Department  
Thapar University  
Patiala

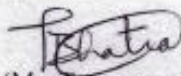
  
(Ms. Tarunpreet Bhatia)  
Lecturer,  
Computer Science and  
Engineering Department

  
(Dr. S. S. Bhatia)  
Dean (Academic Affairs)  
Thapar University  
Patiala

## ACKNOWLEDGEMENT

---

No volume of words is enough to express my gratitude towards my guide **Dr. Shivani Goel** and **Ms. Tarunpreet Bhatia**, Department of Computer Science and Engineering, Thapar University, Patiala, who has been concerned and has aided for all the materials essential for the preparation of this thesis report. She has helped to explore this vast topic in an organized manner and provided me with all the ideas on how to work towards a research oriented venture.

I am also thankful to **Dr. Deepak Garg**, Head of Department, Computer Science Engineering Department, and **Ms. Jhulik Bhattacharya**, P.G. Coordinator, for the motivation and inspiration that triggered me for the thesis work.

I would also like to thank the staff members and my colleagues who were always there at the need of the hour and provided will all the help and facilities, which I required, for the completion of my thesis work.

Most importantly, I would like to thank my parents and the almighty for showing me the right direction out of the blue, to help me stay calm in the oddest of the times and keep moving even at times when there was no hope.

**Simmi Kansal**

## ABSTRACT

---

The increased interest in use and area of Wireless Sensor Networks have given rise to designing of many new routing protocols in which energy awareness is of great importance. In the hierarchical protocols designed till now, the cluster head selection is on the basis of probability equation. The probability equation was applied on the nodes and then the cluster heads were selected randomly. Therefore a new scheme needs to be proposed which would improve CH selection procedure and can help in reducing the energy degradation of CH. The proposed scheme in this thesis introduces GADA-LEACH in which the CH selection method is improved and relay node concept is introduced. For improving the CH selection procedure, Genetic Algorithm is used. In this fitness function is computed by using parameters such as energy of all nodes, energy of cluster heads, distance of CH with its associated nodes, number of nodes in cluster, distance of BS from all CH's and number of CH's formed. Relay node is deployed at the centre of the network. It is rechargeable node. It makes the communication between the BS and CH easy by acting as intermediate between the both.

# TABLE OF CONTENTS

---

---

CERTIFICATE.....	i
ACKNOWLEDGEMENT.....	ii
ABSTRACT.....	iii
TABLE OF CONTENTS.....	iv
LIST OF FIGURES.....	vi
LIST OF TABLES.....	vii
ABBREVIATIONS.....	viii
<b>CHAPTER 1 INTRODUCTION</b>	<b>1</b>
1.1 Introduction to WSNs.....	1
1.1.1 Features of WSNs.....	2
1.1.2 Applications of WSNs.....	3
1.2 Classification of Routing protocols in WSN.....	4
1.2.1 Data Relaying Protocols .....	4
1.2.2 Data Centric Protocols .....	5
1.2.3 Hierarchical or Clustering-based Protocols .....	7
1.2.4 Location-based or Geographical protocols.....	11
1.2.5 Mobility Based Protocols.....	12
1.2.6 Heterogeneous Protocols.....	14
1.3 Factors affecting designing of routing protocols.....	15
1.4 Motivation of Thesis.....	16
1.5 Thesis outline.....	16
<b>CHAPTER 2 RELATED WORK AND LITERATURE SURVEY</b>	<b>17</b>
2.1 Energy Efficient Design of WSN.....	17
2.2 Genetic Algorithm.....	17
2.3 Literature survey.....	18
2.4 Comparison of the routing protocols.....	26
<b>CHAPTER 3 PROBLEM STATEMENT</b>	<b>28</b>
3.1 Objectives.....	28

<b>CHAPTER 4 SIMULATOR INTRODUCTION</b>	29
4.1 Simulator Introduction (MATLAB).....	29
<b>CHAPTER 5 PROPOSED ALGORITHM</b>	31
5.1 Assumptions.....	31
5.2 Proposed Work.....	31
5.3 Proposed Algorithm.....	32
<b>CHAPTER 6 SIMULATION RESULTS AND DISCUSSIONS</b>	35
6.1 Simulation Environment.....	35
6.2 Simulation Results.....	36
6.2.1 Network Structure of GADA-LEACH.....	36
6.2.2 Comparison of Network Lifetime with varying initial energy.....	37
6.2.3 Comparison of Network Lifetime with varying packet size.....	39
6.2.4 Comparison of Packets Delivered to Base Station.....	41
<b>CHAPTER 7 CONCLUSION AND FUTURE SCOPE</b>	44
7.1 Conclusion.....	44
7.2 Future Scope.....	44
<b>REFERENCES</b> .....	45
<b>LIST OF PUBLICATIONS</b> .....	50
<b>VIDEO PRESENTATION</b> .....	51
<b>PLAGIARISM REPORT</b> .....	52

## LIST OF FIGURES

---

---

Figure 1.1	Wireless Sensor Network Architecture	1
Figure 1.2	Main hardware components of sensor	2
Figure 1.3	SPIN Protocol	6
Figure 1.4	Architecture of LEACH	9
Figure 1.5	Virtual Grid in GAF	12
Figure 2.1	Flowchart of Genetic Algorithm	18
Figure 4.1	Desktop view of MATLAB	30
Figure 5.1	Flowchart of GADA LEACH	34
Figure 6.1	Network Structure of GADA LEACH	36
Figure 6.2	Plot of comparison of network lifetime LEACH, LEACH-E, LEACH-EX and GADA LEACH at $E_o=0.3$	37
Figure 6.3	Plot of comparison of network lifetime LEACH, LEACH-E, LEACH-EX and GADA LEACH at $E_o=0.4$	38
Figure 6.4	Plot of comparison of network lifetime LEACH, LEACH-E, LEACH-EX and GADA LEACH at $E_o=0.5$	38
Figure 6.5	Network Lifetime of LEACH, LEACH-E, LEACH-EX and GADA LEACH when varying $E_o$	39
Figure 6.6	Plot of comparison of network lifetime LEACH, LEACH-E, LEACH-EX and GADA LEACH when packet size=2000	39
Figure 6.7	Plot of comparison of network lifetime LEACH, LEACH-E, LEACH-EX and GADA LEACH when packet size=3000	40
Figure 6.8	Plot of comparison of network lifetime LEACH, LEACH-E, LEACH-EX and GADA LEACH when packet size=4000	41
Figure 6.9	Network Lifetime LEACH, LEACH-E, LEACH-EX and GADA LEACH when varying packet size	41
Figure 6.10	Packets Delivered to Base Station in LEACH	42
Figure 6.11	Packets Delivered to Base Station in LEACH-E	42
Figure 6.12	Packets Delivered to Base Station in LEACH-EX	43
Figure 6.13	Packets Delivered to Base Station in GADA LEACH	43

## LIST OF TABLES

---

Table 2.1	Comparison of hierarchical routing protocols of WSN	27
Table 2.2	Comparison of routing protocols based on location awareness and network distribution	28
Table 6.1	Simulation Parameters	36

## LIST OF ABBREVIATIONS

---

APTEEN	Adaptive Periodic Threshold-sensitive Energy Efficient Sensor Network protocol
BS	Base Station
CCM	Chain and cluster based routing protocol
CH	Cluster Head
DAIC	Distance Aware Intelligent Clustering
GA	Genetic Algorithm
GAF	Geographic Adaptive Fidelity
GADA LEACH	Genetic Algorithm based and Distance Aware LEACH
GEAR	Geographic and Energy-Aware Routing
GSTEB	General Self-Organized Tree-Based Energy-Balance Routing protocol
EEHC	Energy Efficient heterogeneous clustered scheme for WSN
HEED	Hybrid Energy Efficient Distributed Protocol
IBLEACH	Intra balanced LEACH
LBDD	Line Based Data Dissemination
LEACH	Low Energy Adaptive Clustering
EAGRP	Energy Aware Geographic Routing Protocol
ECLEACH	Enhanced Centralized LEACH
LEACH-E	Energy LEACH
LEACH-EX	Extension to LEACH-E
M-LEACH	Multihop LEACH
MOECS	Multi-criterion optimization
PEGASIS	Power-Efficient Gathering in Sensor Information Systems
QoS	Quality of service
REQ	Request
SEP	Stable Election Protocol
SPIN	Sensor Protocols for Information via Negotiation

TEEN	Threshold sensitive Energy Efficient sensor Network protocol
V-LEACH	New Version LEACH
WSNs	Wireless Sensor Networks
WB-TEEN	Well Balanced TEEN protocol
WBM-TEEN	Well balanced TEEN with Multi-Hop Intra-Cluster

# CHAPTER 1

## INTRODUCTION

---

### 1.1 Introduction to Wireless Sensor Networks (WSN)

WSN consists of mobile or stationary sensor nodes which are spatially distributed for sensing the event and processes the data and passes the gathered data to base station through some intermediate nodes. Sensor nodes sense the event according to their application interest from some predefined geographical area. Due to mobility in sensor nodes, the topology of network changes dynamically [1, 2].

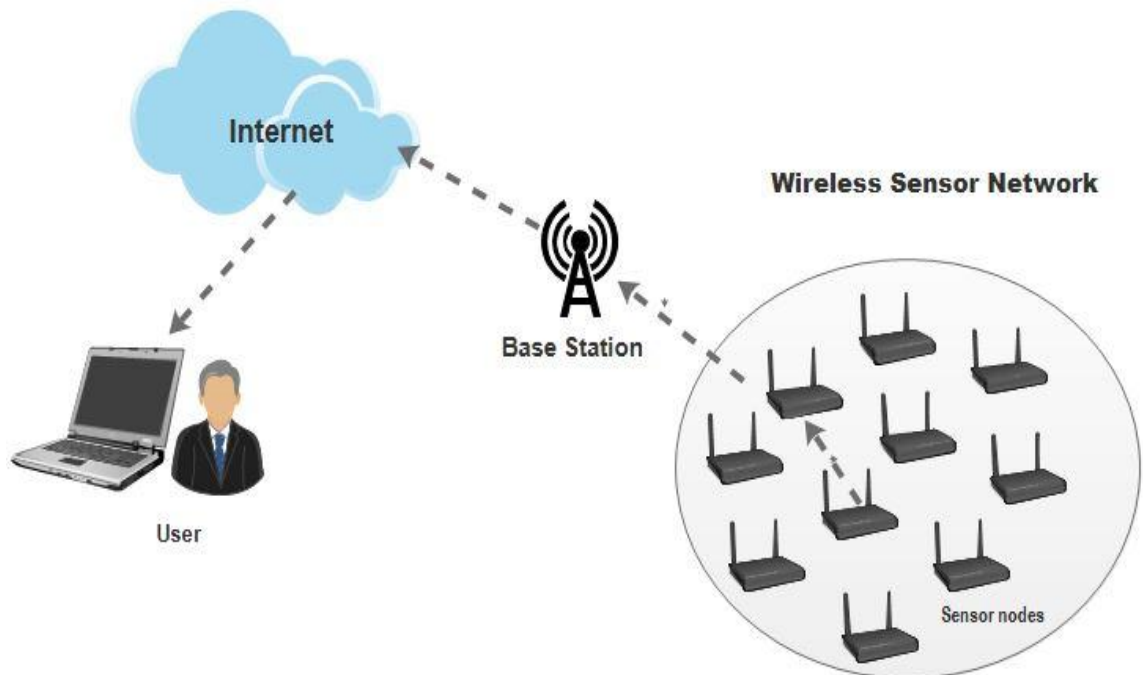

+

Figure 1.1 Wireless Sensor Network Architecture

Sensor nodes consist of Memory, Power Supply, Sensors/Actuators, Communication device, Controller as shown in fig 1.1. In addition to sending the sensed data Sensor nodes can make some computations and complete the tasks using its processing capability. Moreover it can just send the processed data in the network instead of sending the raw of data.

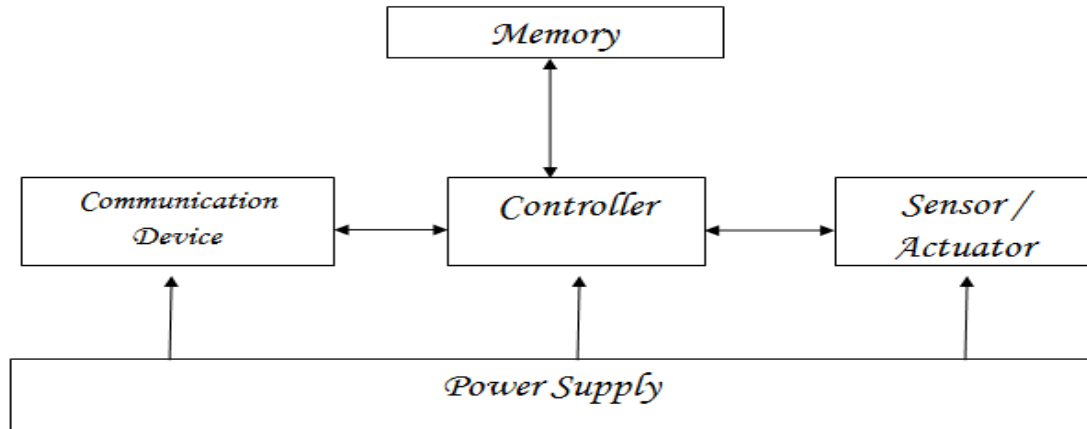

Figure 1.2 Main hardware components of sensor

Some of the limitations from which sensor nodes suffer are limited energy battery source, lower data rates, slower computing speeds, smaller memory and limited communication range. These limitations are taken care of while designing the routing protocols as they directly impact functioning of whole network [3]. WSN is used basically for monitoring of physical and environmental conditions such as temperature, sound, pressure etc. Some of its applications include Area monitoring, Air pollution monitoring, Industrial monitoring, Forest fire monitoring, landslide monitoring etc [4].

Due to resource constrained nature of WSN traditional routing approach can't be applied to WSN [5, 6]. Also unlike traditional routing protocols, most of the traffic in WSN is routed from nodes to Base Station. The focus of routing approaches in WSN is more in finding out the routes that may result in prolonged lifetime of the network and less focus is given on routes with shortest distance, minimum delay or maximum bandwidth because of energy constraints of sensor nodes.

### 1.1.1 Features of WSN

- Collaborative Objective:** The objective of sensor nodes is to sense the event in the environment & transmit the sensed data to the Base Station (sink node). There is no competence among the nodes rather they associate with each other to transmit the data [7]. For example to increase the network lifetime nodes send data through multi hop communication.

- **Network Scale:** There are applications with small number of sensor nodes (i.e. 10-20) and some with large number of sensor nodes (150-1500). WSN consisting of large number of nodes have become common due to development of sensor nodes in Integrated circuit design technology which have made its cost relatively very low. Also problem of node failure can be dealt with as alternate paths get available to reach the sink.
- **Many to One Communication Paradigm:** Sensor nodes monitor the event according to its interest and transmit it to the Base Station. There can be many to one communication when data flows in upward direction that is when sensor nodes forward their reports to the sink or there may be one to many communications when data flows in downward direction that is when sink sends queries or commands to the sensor nodes.
- **Clustering for Scalability:** Sensor nodes must be arranged in clusters called smaller sub-networks. This results into lower routing overheads.
- **Node Deployment versus Placement:** The deployment of sensor nodes can be done either by throwing them randomly over area of interest (forest fire detection, battlefield detection etc.) or by their placement one by one at particular locations (temperature & light monitoring in a building, seismic monitoring of buildings etc.). In second placement method ensuring the Network connectivity is relatively easier than in the first method of placement.
- **Network Mobility and Dynamic Topology:** Sensors nodes are either stationary or mobile according to the application they are deployed for. Therefore according to these mobile nodes, network topology gets changed and so information about the routing needs to be updated.

### 1.1.2 Applications of WSN

Tracking and monitoring are the main applications of WSN and they can be further divided as follows:

- **Area Monitoring:** In this the environmental conditions are monitored. Some environmental applications of sensor networks include tracking the movements of

birds, small animals, and insects, monitoring environmental conditions that affect crops, Forest fire detection, Flood detection etc.

- **Health care Monitoring:** Some of the health applications for sensor networks are setting of sensors inside the body of patient so that doctors can monitor patient.
- **Air pollution Monitoring:** In this monitoring is done for the checking the levels of the pollutants in the environment. So that during their high levels effective measures can be taken. By installing a sensor device, pollution can be checked and this will make that city a smart city.
- **Natural Disaster Prevention:** Natural disasters can be prevented by having proper check by deploying sensor nodes in the vulnerable areas and nearby areas can be alerted before any mishappening.
- **Industrial Monitoring:** In industry sensor nodes can be deployed inside the machinery to keep eye on the threshold levels that they are maintained for proper working of the machinery.
- **Agriculture:** For finding the amount of pesticides and fertilizers best suited for crops and to analyze whether a crop is affected by insect etc.
- **Vehicular monitoring:** Deployment of Sensor nodes on roads or in vehicles so as to trace them and this will be beneficial in reducing accidents and maintain traffic.

## **1.2 Classification of Routing Protocols in WSN**

Routing protocols in WSNs have a common objective of efficiently utilizing the limited resources of sensor nodes in order to extend the lifetime of the network. Different routing techniques can be adopted for different applications based on their requirements. Applications can be time critical or requiring periodic updates, they may require accurate data or long lasting, less precise network, they may require continuous flow of data or event driven output. Routing methods can even be enhanced and adapted for specific application [8]. These protocols can be classified into six categories:

### **1.2.1 Data Relaying Protocols**

These protocols do not require any routing table and do not require maintaining topology information about the network, so these protocols are simple and easy in the implementation.

- **Gossiping**  
Gossiping protocol is the improvement to the Flooding. In flooding the node broadcasts the packet to all its neighbors and the same process continues by all the neighbors receiving the flooded packet. This results into creation of multiple copies in the network. But whereas in Gossiping the node sends packet to one of its randomly selected neighbor and this neighbor node forwards this packet further to its randomly selected neighbor. This process continues till the packet reaches the destination node. The advantage of this protocol is in reducing the energy consumption than the Flooding and solves the Implosion problem as each node have just one copy of the message[9]. One of the main drawback is the occurrence of long propagation delay.
- **Flossiping**  
This protocol is the combination of Gossiping and Flooding. The node forwards the packet in gossiping mode by deciding a threshold value and saves this value in the packet header. The node receiving the packet generates a random number, if this random number is less than the threshold value then it chooses Flooding else it chooses Gossiping for sending the packet.
- **LGossiping**  
This is improvement over the Gossiping protocol in which the node chooses the neighbor closer to it on the basis of GPS location information. So the requirement in this protocol is for the nodes to have the location information through the GPS device. Thus in this the long latency problem gets reduced but the cost increases due to the need of GPS device in the nodes.

### 1.2.2 Data Centric Protocols

These are classification of routing protocols in which the set of sensor nodes are selected based on the Query driven model.

- **SPIN (Sensor Protocol Information via Negotiation)**

This protocol overcomes the limitations of Flooding & Gossiping Protocol. In this protocol the node having data to send, issues the ADV message to its neighbor nodes as shown in fig 1.3. The node interested in receiving this data issues REQ to the source node. Then source node complete the whole message by sending DATA message.

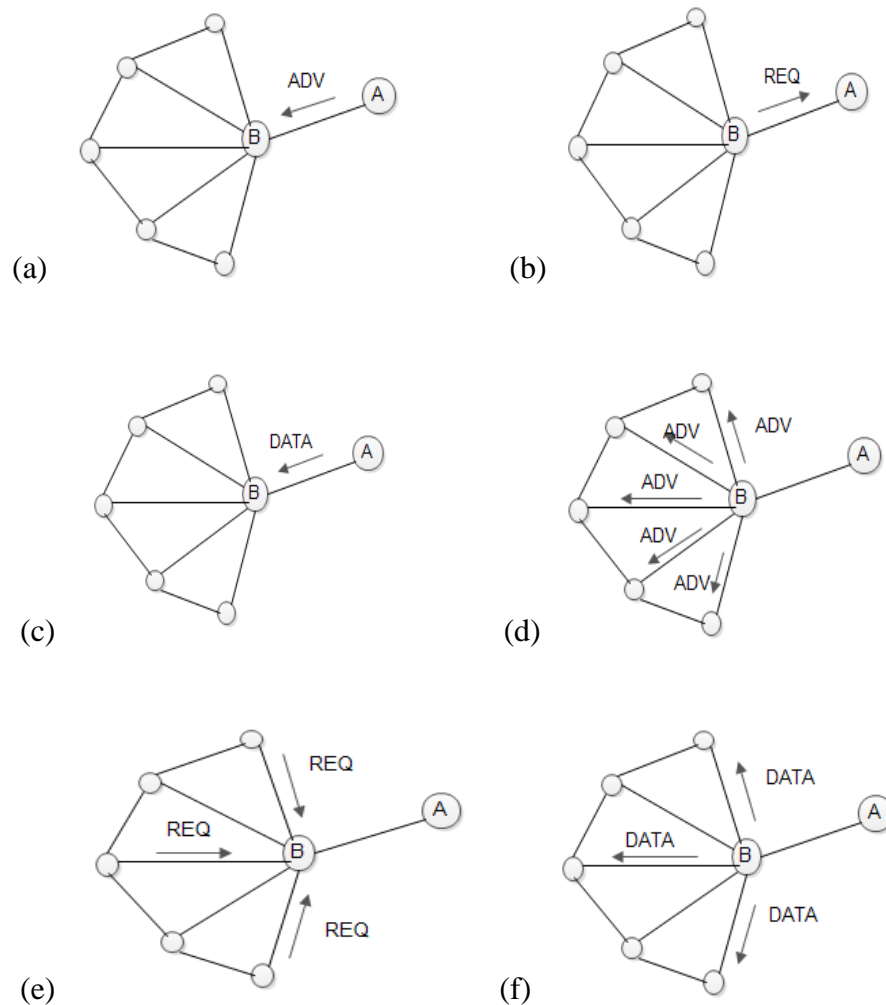

Figure 1.3 SPIN Protocol (a) node A sends ADV to node B. (b) Node B sends REQ to node A. (c) Node A sends data to node B after receiving its request. (d) Node B sends ADV to neighbor nodes. (e) Neighbor nodes request for data to node B. (f) Node B responds with requested data.

The advantage of this is that it achieves reduction in energy consumption than that of Flooding by a factor of 3.5. The drawback is that it doesn't guarantee delivery of data to the potential neighbors as they may be very far away from the source node because intermediate nodes may also not be interested in this data.

- **Modified SPIN**

In MSPIN the information is transmitted only to the sink node rather than sending it to the whole network. Thereby resulting into faster response to the sink node. Also the total number of packets transmission is lesser in this protocol than in SPIN.

- **Directed Diffusion**

In this protocol the sink node sends query messages to the sensor nodes. The sensor nodes then response to the query messages of the sink. The main advantage of this is that due to its on-demand nature lesser amount of energy is consumed and suffers from lesser delay. The disadvantage is that the scope of this is limited to particular application because of its dependence on queries by sink which would not be feasible for WSN networks that require continuous data by the sink.

### 1.2.3 Hierarchical or Clustering-based Protocols

Due to increase in the number of sensor nodes WSN overload on single Gateway increases due to large amount of data. So the solution to this problem is breaking the network into multiple clusters having Cluster Head and Cluster members.

CH performs fusion of all the data received from its members before sending it to the sink node. The cluster is elected on the basis of node with higher energy reserve.

- **LEACH (Low Energy Adaptive Clustering Hierarchy)**

In LEACH protocol there is formation of clusters with each cluster having cluster head and cluster members as shown in fig 1.4. The process of generating clusters of nodes where one node acts as a Cluster head is performed in periodical manner, diving every round into two phases: a)

Cluster Building Phase: One of the node is elected as a Cluster head by following cluster head election process. Then this CH sends message to non cluster nodes informing about its new role. The non cluster nodes sends joining request to the Cluster head on the basis of received signal strength. b) Stable Data Communication Phase: Cluster member's sends data to the Cluster head, then CH aggregates the received data and forwards it to the sink node.

CH consumes more energy than ordinary nodes as they fuse the data received and sends it to the sink node. So LEACH algorithm also guarantees that each node has equal possibility of being elected as CH in further rounds due to which it ensures that every node consumes energy relatively equally [10].

Procedure of Cluster Head Selection in LEACH: Every node produces random number between 0 and 1 and the node announces itself as CH if this number is less than Threshold value  $T(n)$ . The value of  $T(n)$  is set to zero for the node that have been already acted as CH so that this node doesn't get selected as CH again. The nodes that have not been selected as CH, they have  $T(n)$  possibility of being selected as CH.

$$T(n) = \begin{cases} \frac{p}{1-p(r \bmod \frac{1}{p})} & \forall n \in G \\ 0 & \text{if } n \notin G \end{cases}$$

Where:

P is desired percentage of CH that is the probability of CH node election, r is the current round, and G is the set of nodes that haven't been selected as CH in last 1/P rounds [11].

**Problems with LEACH Protocol:** In LEACH protocol the selection of Cluster Head is in randomized rotation fashion. But this is an ideal result based on following two prerequisites: a) Initial energy of nodes should be equal. b) Each node must consume equal energy during its phase as CH.

Condition (b) is difficult to be achieved because of difference in distance from CH to Base station due which consumption of energy is different for all the

nodes i.e. slower for some nodes and faster for some. Also it could after happen after certain period of time that nodes with lesser energy gets elected as Cluster head and which causes acceleration in death of nodes and reduction in network life cycle.

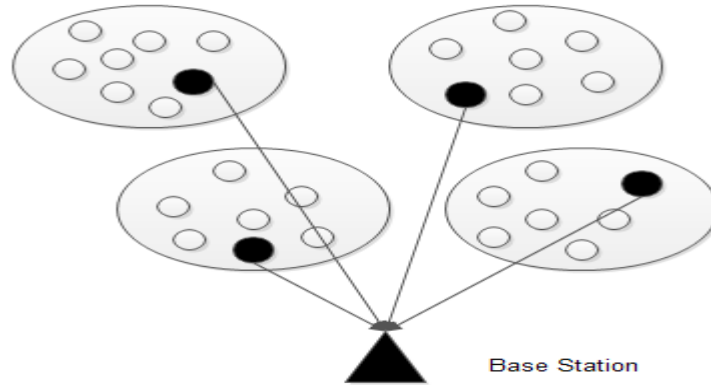

Figure 1.4 Architecture of LEACH

- **E-LEACH (Energy LEACH)**

E-LEACH protocol is an improvement over LEACH in which during the second round of the selection of the Cluster Head the residual energy of nodes is also considered thereby making the network more energy-efficient than LEACH.

In E-LEACH minimum spanning tree is used between Cluster heads, in choosing the Cluster Head having the largest residual energy as root node [12].

Also the balancing of energy depletion of the nodes in LEACH-E is done by following two methods: first is by the consideration of current energy of nodes during their selection as CH and second is by limiting the number of nodes in each Cluster.

The Cluster Head selection procedure formula in this protocol:

$$T(n) = \begin{cases} \frac{p}{1-p(r \bmod \frac{1}{p})} * \sqrt{\frac{E_{current}}{E_o}} & \forall n \in G \\ 0 & \text{if } n \notin G \end{cases}$$

Where:

$P$  is desired percentage of CH that is the probability of CH node election,  $r$  is the current round,  $G$  is the set of nodes that haven't been selected as CH in last  $1/P$  rounds,  $E_{\text{current}}$  is the current energy of the node and  $E_0$  is initial energy of node.

- **M-LEACH (Multihop LEACH)**

This protocol solves the problem of LEACH when Cluster Head is located far away from the sink node in which huge amount of energy is consumed for the direct or single hop transmission between Cluster Head and the sink node [6].

- **WB-TEEN (Well balanced TEEN protocol)**

The main purpose of this protocol is reducing the energy consumption obtained during the balancing process of clusters. Node after getting elected as CH then it sends an ADV message to the non cluster nodes. The non cluster nodes send JOIN\_REQ to the CH with the strongest signal strength. Each CH calculates its degree. On receiving the JOIN\_REQ the CH checks its degree, if the nodes have not reached its degree then that node is selected as its cluster member else its membership requested is rejected. After the formation of clusters each CH forwards out the Hard and Soft threshold values to its cluster member nodes. Hence with this protocol each cluster formed is node balanced [13].

- **WBM-TEEN (Well balanced TEEN with Multi-Hop Intra-Cluster)**

This protocol deals with the problem of early death of the nodes located far away from the Cluster Head than the nodes that are located near. This protocol is improvement to WB-TEEN in which the nodes located farther from CH sends the data to CH by following multi hop communication through its neighbor instead of following the single hop communication which is more costly in terms of energy consumption [13].

- **LEACH-EX (Extension to LEACH-E)**

This protocol is extension to LEACH-E protocol. The Cluster Head selection procedure formula is:

$$T(n) = \begin{cases} \frac{p}{1-p(r \bmod \frac{1}{p})} * \frac{E_{current}}{E_0} & \forall n \in G \\ 0 & \text{if } n \notin G \end{cases}$$

Where:

P is desired percentage of CH that is the probability of CH node election, r is the current round, G is the set of nodes that haven't been selected as CH in last 1/P rounds, E<sub>current</sub> is the current energy of the node and E<sub>0</sub> is initial energy of node.

The use of square root in T (n) calculation of LEACH-E introduced computational overhead. As the root of number gives lesser value than just number itself, so also in this use of square root reduced the overall probability value. Also with this decrease in overall probability, number of CH getting elected also gets reduced. So this drawback is improved in LEACH-EX protocol.

#### 1.2.4 Location-based or Geographical protocols

These types of protocols are location dependent protocols i.e. they depend on sensor nodes location information in finding the most energy efficient path between the nodes and the sink node. In this the nodes are deployed with GPS devices to make their location information available but this result into increase in cost of sensor nodes. So instead of use of GPS devices, some localization algorithm can also be used which are cost effective in finding out the position of the node, but this information may suffer from inaccuracy or approximation in the position of node.

- **GAF (Geographic Adaptive Fidelity)**

In this approach there is formation of Virtual grid for the covered network area as shown in fig 1.5. Each node by using its GPS indication location positions itself in their respective virtual grids. The nodes which are in same grid will have same cost of routing the packets. By using this equivalence the nodes located in same grid area are kept in the sleeping state to save the energy. Hence they become energy efficient.

The usefulness of this protocol lies in the fact that in this Network lifetime gets increased due to increase in the number of sensor nodes. Also this is energy efficient as some nodes move into the sleep state. But besides all this the usage of GPS device adds to increase in the cost.

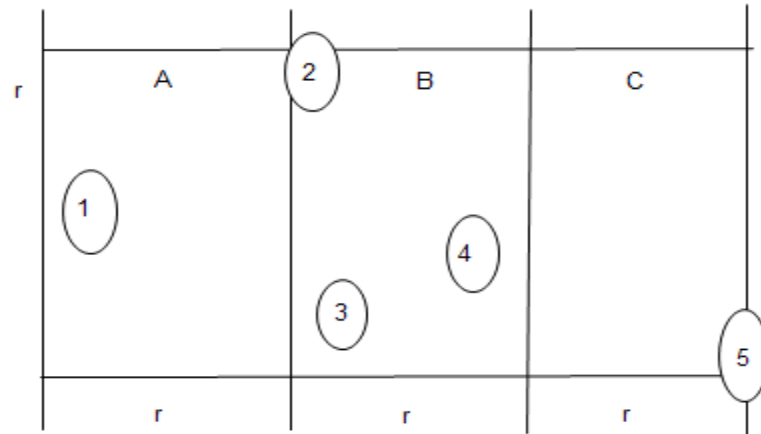

Figure 1.5 Virtual Grid in GAF

- **GEAR (Geographic and Energy Aware Routing)**

GEAR is an improvement over the Directed Diffusion protocol in which the propagation of query messages is restricted to certain region only rather than to the whole network as like in Directed Diffusion.

This is possible in GEAR because in this each node is able to possess the location information and the remaining information regarding itself and its neighbors.

### 1.2.5 Mobility Based Protocols

Most of the applications of WSN consist of static sensor nodes. But also sometimes to have better connectivity and coverage of wider area, the nodes are equipped with mobility feature having restricted movement.

It may also happen that sink node may also be mobile putting challenges in routing the data. So these protocols are designed by considering the mobile nature of both sink node as well as other nodes of the network.

- **EAGRP (Energy Aware Geographic Routing Protocol)**

In this the requirement of EAGR algorithm is that each node must advertise its location, fraction of energy consumption and the rate of energy consumption. Because in this cost metric of a node is dependent on all these parameters.

Then EAGR hello packet which contains all this information and node ID is broadcasted to all its neighbors. By receiving this packet each node creates a neighbor table containing above three parameters and ID as the fourth parameter. Every time on receiving this packet the nodes update their neighbor table entries.

Now whenever the nodes have the data to be forwarded then they select the next node which is energy efficient i.e. the node having minimum energy consumption and maximum remaining energy and its nearness to the destination node is also considered.

The selection of Energy Efficient route is made and the drawback of this lies in the cost of GPS device to be deployed per node.

- **LBDD (Line Based Data Dissemination)**

This protocol forms the basis of the fact that there may be multiple sink nodes in sensor field moving randomly. The assumption made in this protocol is that every node has its location information either through the GPS device or through some virtual co-ordinate system.

In this it defines a Virtual Vertical Line that middle intersects the sensor field into two parts. This line itself is divided into g-groups. The nodes that lie closer to the line boundary are called as In-line nodes and the nodes away are called as Ordinary nodes.

In this data towards the sink node is forwarded in two phases: In phase 1, the ordinary nodes generate new data and forward it to the In-line node nearest to them. In phase 2, when sink node requires the data then it forwards query message towards the line (in perpendicular fashion). Then the first In-line node receiving this query sends this query to all in both the directions along perpendicular line until it reaches the inline node that owns the data. Then

finally the owner of data forwards data directly to sink only when it owns new copy of the data.

### 1.2.6 Heterogeneous Protocols

Homogeneous network consists of sensor nodes having equal initial energy reserve and all the nodes consume energy at same rate. But whereas in homogeneous network, the nodes have different hardware characteristics for performing various tasks and have different initial energy reserve.

So the routing protocols for heterogeneous networks are different from that of homogeneous networks.

- **LEACH-HPR**

In this protocol the sensor nodes are partitioned into three categories: A, B and C. The energy reserve of these node categories is from the lowest energy to highest energy. While selecting next CH it considers the current energy reserve of the nodes. Each node starts up a timer initialized to value which is reciprocal of its current energy reserve. Then timer countdown is started by node at a predefined rate. The nodes start listening to the channel for any message destined to it by their neighbors. The node which has not received any message yet but has its timer reached to zero, will declare itself as CH and broadcasts an ADV message to the nodes. Nodes on receiving the ADV message sends the joining request to the CH from which it received the strongest strength signal.

Thus this protocol is useful in reducing the energy consumption by the nodes and increases the network lifetime.

- **SEP (Stable Election Protocol)**

This protocol is designed for clustered heterogeneous WSN. It tries to increase the time interval of expiry of first node of the network. The assumptions in this are that in comparison to the other nodes the sink node is not energy restricted. During the election of the Cluster Head node it follows the heterogeneous awareness in the sense that the probability of the node to be selected as CH is dependent on the initial energy reserve of the node relatively

to that of other nodes competing. Thus it maximizes the stability period of WSN [14].

### 1.3 Factors affecting designing of routing protocols

There are many factors that affect the designing of the routing protocols and some of those are given below [15]:

- **Node Deployment:** Node Deployment can either be deterministic or can be randomized depending upon the operation to be performed by the application and routing should be done in order to provide best performance.
- **Node/Link heterogeneity:** Heterogeneous nodes are those nodes which have different hardware characteristics for performing various tasks and have different initial energy reserve. This result into many technical problems related to routing of data and needs to be tackled.
- **Data-Reporting model:** Data-Reporting in WSN can be categorized into following: Time driven (continuous), query driven, event driven and hybrid. Depending on these categories the routing protocols must be designed so that particular task can be performed efficiently.
- **Scalability of Network:** Routing protocols used must be scalable enough in order to respond to the events in the case when there is huge increase in the number of sensor nodes.
- **Fault Tolerance:** Routing protocols need to be designed in such a way that any failure in the nodes should not affect the overall task of the sensor network.
- **Connectivity among nodes:** Connectivity of nodes play an important role in routing of the data from node to node till it finally reaches the end user.
- **Quality of Service of data:** Data to be delivered should be done in certain period of time. So that the purpose of real time related applications gets fulfilled with efficient on time delivery of data. The conservation of energy of nodes is directly related to the lifetime of the network. So energy efficient routing protocols contribute in increasing the lifetime of network.

## **1.4 Motivation of Thesis**

Clustering provides network scalability, resource sharing and efficient use of constrained resources that gives network topology stability and energy saving attributes in WSNs.

LEACH is considered as the most popular routing protocol using cluster based routing so as to minimize the energy consumption. But LEACH doesn't take into account of the distance and the residual energy of the nodes to be selected as CH node. Thus, there are chances that energy consumption in the network is not distributed in uniform manner. So the new proposed approach is designed in a way that considers these factors during the selection of cluster head and network performance can be improved.

## **1.5 Thesis Outline**

The rest of the thesis is organized as follows: Chapter 2 describes introduction to energy efficiency design of routing protocols. Also it describes about the most relevant existing work in routing protocols of WSN. Chapter 3 describes about problem statement. Chapter 4 explains about simulator used for results. Chapter 5 explains proposed work and methodology used. Chapter 6 presents simulation results and discussion. Chapter 7 concludes the proposed work and discusses future work.

#### **2.1 Energy Efficient Design of WSN**

The main critical issue nowadays during the design of routing protocol of WSN is energy efficient routing protocol. Research on energy efficient protocols is going on for a long time. For protocol to be energy efficient many parameters have to be focused upon. Some of them are network topology, data forwarding techniques, distance between the nodes and BS and many more. Many parameters need to be kept in mind during designing the protocol. In hierarchal routing protocols the main consideration for making it energy efficient is concentrating on the formation of clusters.

#### **2.2 Genetic Algorithm**

Genetic Algorithm is an evolutionary algorithm used to generate solutions to optimization and search problems. It uses techniques inspired by natural selection to obtain the optimized results. Such techniques are selection, crossover and mutation.

The first step is initialization of the population in which the initial population is generated randomly and the size of population is dependent on the nature of the problem. The second step is selection. In this the population from the initialized population is selected based on the fitness function defined. The individuals selected are parents and are used in next generation to contribute in the generation of the population. Fitness function is defined on the basis of particular problem. It differs from problem to problem. Fitness function is used to select individual solutions and to measure the quality of the solution.

There are two genetic algorithm operators: crossover operator and mutation operator.

Crossover operator combines two parents to generate new children. The basic idea behind doing this is that the new children formed takes the characteristics of both parents and will be better than the both. Mutation operator forms new children by applying random changes to the individual parents.

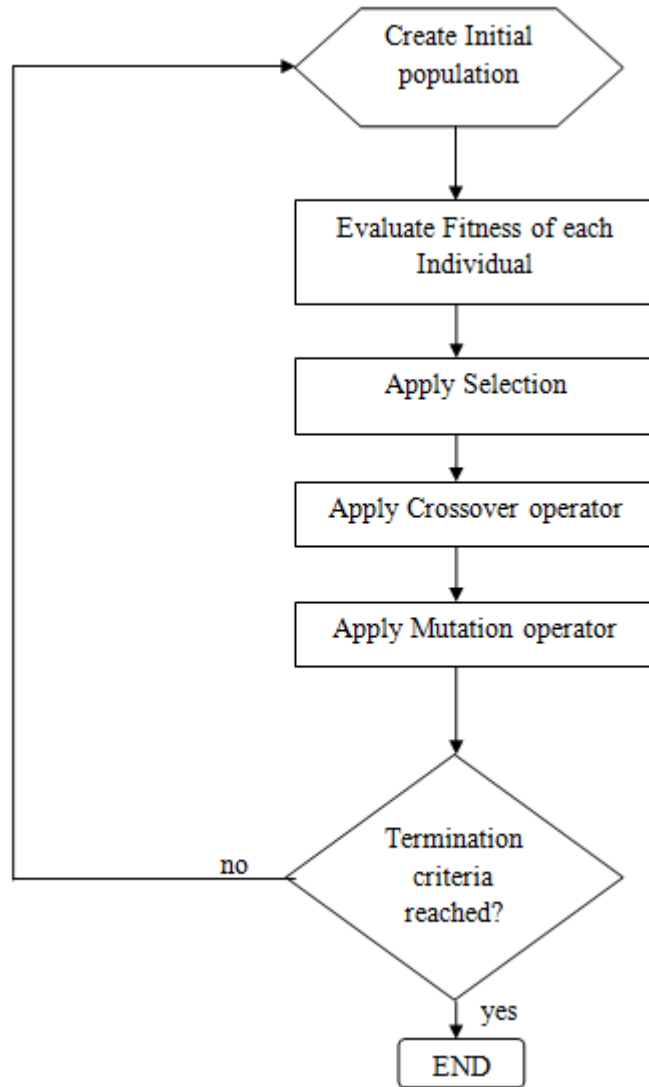

Fig 2.1 Flowchart of Genetic Algorithm

### 2.3 Literature Survey

Ahmed Salim *et al.* [16] proposed a clustering routing protocol IBLEACH for balancing the energy consumption in the wireless sensor networks which is an improvement to hierarchical based protocol LEACH in terms of the minimization of energy consumption and the lifetime of the network. In this protocol a new phase i.e. pre-steady phase is introduced between the setup phase and steady phase of round whereas LEACH consists of only two phases. So in this protocol one round consists of three phases. Similar to the LEACH protocol in setup phase there is random election of Cluster head and dynamic formation of the clusters. In the pre-steady phase the cluster workloads is calculated in

one frame, and from the Cluster nodes select the CM for handling the process of data aggregation in the round through all the frames. If any such type of node doesn't exist, then CM is elected for handling the aggregation process for each frame in the round and the frames that do not have aggregators, their aggregation process is handled by the CH itself. The sensor nodes by end of this phase are divided into two categories i.e. CH and CM in each frame. The third phase i.e. the steady state phase is divided into frames [17]. All the nodes transfer their data in each frame to the aggregator in their time slots. Once the aggregator receives all the data from the nodes, it gathers the whole data and forwards it to Base Station.

Feilong Tang *et al.* [18] proposed a protocol CCM (chain-cluster based routing algorithm) that removes the demerits of LEACH and PEGASIS in terms of transmission delay and energy consumption [19, 20]. A chain is a set of sensor nodes and each having head node in turns. This protocol is divided into two phases: Chain based routing and Cluster based routing. The first phase i.e. Chain based routing is composed of following two steps. In the first step Selection of chain head of chain is made. Sensor nodes in chain are referred by  $N(i, j)$  where  $i$  is the chain number and  $j$  is the sensor node number and  $(1 \leq j \leq n)$  where  $n$  is the number of sensor nodes in the chain. To uniform the energy consumption of the nodes in chain every node in the chain is chosen as chain head in turn. In the second step data is dispatched to the head node of the chain. After the selection of head node two tokens are generated by it and send it to the first and last node of the chain. The first and the last node along with token pass the data to the neighbor nodes. This process continues till data from all chain nodes and both the tokens reach the head node. After collection of data from all chain nodes, head node destroys both the tokens and fuses the data received.

The working of second phase i.e. cluster based routing is in following two steps. After completion of first phase all the head nodes build a new cluster and other chain nodes of all the chains enter into sleep state. Selection of cluster head is made in up in the first step. One of the chain head which have the higher residual energy is appointed as cluster head. For selection process all the chain heads broadcasts their residual energy to other chain heads (member of cluster). Each cluster member matches others residual energy with its own. If any member node detects its residual energy to be higher than other, it

then send advertisement message to other member nodes as it being applying to work as cluster member. In case of two or more head nodes having conflict of same residual energy, the node issuing the advertisement first is appointed as cluster head. In the second step there is transmission of data to the cluster head by all the cluster member. So each cluster node is assigned with individual TDMA time slot to forward the data to cluster head. Cluster head after receiving the data, aggregates it and transfers it to sink node.

Aslam *et al.* [21] proposed a protocol MOECS (Multi-criterion optimization technique for energy efficient cluster formation in WSN) that aims at optimization of the energy use during cluster formation which means decision of each sensor node in joining a particular cluster on basis of minimum overall communicational cost. In most cases, sensor nodes take this decision based on the strength of signal of advertisement message received by the CH [22]. In some proposed models it also depends on the composite cost metrics such as distance between sensor node and BS, distance between node and CH, and distance between CH and BS that balances load between energy consumption [23]. In this protocol the MCOP (Multi-criterion Optimization) technique is used for the optimization [24].

It uses concept of preference function modeling [25] which on basis of multiple user constraints successfully finds an optimal path [26]. The value from user criterion  $i$  is accepted by the preference function and value  $s(i)$  is returned such that  $s(i)$  scales between 1 and -1. 1 and -1 signifies best and worst respectively. For given criterion to find an optimal choice a decision matrix is built and scaled weighted values for decision process are contained in the preference vector. When sensor nodes receives an advertisement message from CH it then first builds the Option Matrix, followed by Decision Matrix and finally it obtains Weight vector by multiplying decision matrix to the preference vector for obtaining the weight for all the cluster choices available. In cluster formation algorithm the weight vector with maximum weight is finally selected as the best choice and sends that CH the joining request.

Arati Manjeshwar *et al.* [27] proposed a protocol TEEN (Threshold sensitive Energy Efficient Sensor Network protocol) that was basically developed for reactive networks. In these two types of threshold values are used. They are hard threshold value and soft threshold value. These values are broadcasted by cluster head to its members. These are

threshold values for the sensed attribute. Hard threshold is the value of sensed attribute more than which if node senses the value, it must report to its cluster head by switching its transmitter on. Soft threshold refers to the small change in sensed attribute value which signifies the node to transfer the information to its cluster head. The internal variable in which sensed value is stored is called sensed value (SV). The SV is set with sensed attribute current value whenever the nodes transmit the data. The nodes send data to its head only when both of the following conditions are true. Firstly if the sensed attribute value is exceeded by hard threshold value. Secondly if the difference between sensed attributes value and SV is equal to or larger than soft threshold.

Arati Manjeshwar *et al.* [28] proposed a protocol APTEEN (Adaptive Periodic Threshold-sensitive Energy Efficient Sensor Network protocol) that is expansion to TEEN protocol. In this protocol both the threshold values are broadcasted by cluster head to its members. In addition to these values another parameter used is Count Time ( $T_c$ ). Count Time refers to the maximum time period between two successive reports transmitted by the node. This parameter adds proactive component to this protocol. The main advantage of this is over TEEN that by transmission of periodic data, the user has complete picture of the network. So this protocol is suitable for both reactive and proactive networks. It also supports three queries i.e. Historical queries, one-time queries and persistent queries [29,30]. With reference to average energy dissipation and lifetime of network, the performance of APTEEN lies between LEACH and TEEN. Also overhead lies in implementation of threshold based functions.

Navin Gautam *et al.* [31] proposed a protocol DAIC (Distance Aware Intelligent Clustering Protocol for WSN) that involves dividing the network into number of tiers each with gateway CH except the tier furthest from Base Station and each tier consists of selected CH. The consistence of nodes in the network is deciding factor for the number of tiers. In many cases there are two tiers.

This protocol works in rounds which is further split into phases: Setup phase and Steady State phase. In setup phase there is network setup at first followed by routing path construction and schedule creation phase. Network setup phase includes formation of tiers, selection of CH, formation of clusters. In the start each of the node forwards the Base station its residual energy and current location. By using this received information

BS finds vertical distance between the node and itself. Based on this vertical distance nodes are placed into primary and secondary tiers. BS also calculates average vertical distance of nodes by addition of all vertical distances and dividing it by overall number of nodes in the network. The node whose vertical distance is lesser than average vertical is placed in primary tier and node with vertical distance is greater than average vertical is placed in secondary tier. BS then calculates average energy of nodes and compares it with energy level of nodes. In each round CH will be chosen as the node with its energy level greater than average energy of nodes in the tier. For reducing the transmission distance of Gateway CH nodes and the secondary CH nodes, the gateway CH nodes are chosen as those nodes with greater vertical distance from BS. Then finally BS broadcasts message containing primary CH ID, secondary CH ID and gateway CH ID to primary tier, secondary tier and secondary tier respectively. Matching its ID with received message nodes announces itself as CH in its tier and other nodes sends it joining request and thus clusters get. So the main concept of using vertical distances is for dividing the network into tiers and of average node energy is for CH selection.

In routing path construction phase, BS connects the gateway CH in primary tier with CH in the secondary by constructing the routing path. In the same way it also connects gateway CH to CH nodes in primary tier. In schedule creation phase the nodes are assigned with TDMA slots in which they are allowed to transmit the data and go into sleep state. This greatly reduces collision and provides better energy performance. In steady state phase, data transmission occurs which consists of sensing of data by sensor nodes and forwards the data to CH, where the data is gathered. Here the data is fused and is huge in size and number. So it is compressed into single message before transmitting to the BS which helps in energy conservation. Then finally the data the data is routed through path constructed in path construction phase and is forwarded to the BS.

The merit of this protocol is fair distribution of energy load which greatly affects the performance of WSN routing [32-34] in the network and good amount of conservation of energy by selecting the number of CH depending upon alive nodes number to avoid selection of unnecessarily large number of CH's.

Mohammad Bsoul *et al.* [35] proposed a protocol ECLEACH (Enhanced Centralized LEACH) addresses the issue of selection of CH, since its proper selection leads to

reduction in energy consumption and extending the lifetime of the network [36-39]. It works in two phases setup phase and steady state phase. Selection of CH and formation of cluster takes place in setup phase. For CH selection process each node in the network generates a random number (RN) such that  $0 < RN < 1$ . Then RN is compared with threshold value  $T(n)$  where  $n$  is no of nodes. A node is then selected as CH if its RN is less than  $T(n)$ . Threshold also helps in ensuring that the nodes which have been CH in last  $\frac{1}{p}$  rounds doesn't get selected as CH in current round. After the selection of CH's, every node gets selected broadcasts nodes that it has been selected as CH. The nodes then sends joining request to the CH based on strength of the signal received and clusters get formed. Then CH sends TDMA slots assignment to the nodes in which they transmit the sensed data to CH. Also for reducing the intercluster interference CH creates a CDMA (Code Division Multiple Access) code for the member nodes. In steady state phase all the nodes in their assigned TDMA slots transfers the data to the CH where the whole data is fused and forwarded to the BS [40].

This protocol is based on centralized approach in which the responsibility of CH selection process is on the BS which has unlimited resources in terms of power, storage and computation. This protocol is similar to LEACH except the process of CH selection. At the beginning of each round, BS computes threshold for all the nodes in the network. Then highest threshold value node is selected as the first CH. For proper and efficient distribution of CH in the network the concept of MDBECHAN (minimum distance between every CH and the next) is utilized in this protocol. This also ensures that all CH's are not concentrated together in the network. Then it checks for node with second highest threshold, if the distance of this node with first highest threshold node is greater than or equal to MDBECHAN then it is selected as second CH. If this doesn't satisfy then it compares distance between first highest threshold node and third highest threshold node with respect to MDBECHAN. In case if BS is not able to meet the condition of MDBECHAN then the value of MDBECHAN is decreased. Once all the CH's get selected, their list is broadcasted by BS in the network.

Zhao Han *et al.* [41] proposed the protocol GSTEB (General Self-Organized Tree-Based Energy-Balance Routing protocol for WSN) which mainly balances the energy load and enhances the lifetime of network of various applications. It works into Initial phase, Tree

construction phase, self-organized data collection and transmission phase and information exchanging phase. In the Initial phase, BS sends all nodes a packet which carries the information about starting time, time slot length and number of nodes in the network. After receiving this information all the nodes compute EL (Energy Level) value which is parameter for load balance which is just an estimated value.

$$EL(j) = [\text{residual energy}(j)/a]$$

Where  $j$  is the ID of the node and  $a$  is constant reflecting minimum energy unit. Then every node sends out packet containing a preamble and its coordinate's information in circle with radius  $R_c$  in its allocated time slot. The  $j_{th}$  node sends this in the  $j_{th}$  time slot. Every node monitors the channel during this time slot [42] and nodes which are neighbors of  $j_{th}$  node will receive this packet and saves this information in its memory else other nodes will go into the sleep state. Once all the nodes have sent the packets containing their information, all their neighbors have this information recorded into tables in their memory. After this step all the nodes then send packets to their neighbors containing information about their neighbors. On receiving this nodes record this into their memory. Now in the end of initial phase all the nodes have two tables containing information about their neighbors and neighborers neighbors in their memory.

Now GSTEB works in round. All other phases are part of a round. In tree constructing phase, for balancing the network load BS chooses a node as root node which has largest residual energy and then broadcasts its node ID in the network. By using record of table 1 (coordinates) and EL value each node select parent in its neighbor. For selection to be efficient for a sensor node the distance between itself and the root must be greater than distance between its parent and root. If node doesn't find any node that satisfies this then it select root as its parent. Using the record of table 2, every node by computing can know parent node and child nodes of its neighbor. In case if node has no child node then it itself is leaf node and transmission of data begins from it. In this way routing tree gets constructed with record of table 1 and table 2.

Lindsey *et al.* [43] proposed a protocol PEGASIS (Power Efficient Gathering in Sensor Information Systems) in which the chain is formed by nodes and the data is transferred by the node to its closest neighbor. The nodes communicate to the BS by taking turns for transmission. In turns nodes become head and perform data fusion and then passes the

data to the BS. Thus by reducing the amount of energy spent per round. Forming of chains can be done either by sensor nodes themselves by use of greedy algorithm or the chain computation can be done by BS and broadcast it to all sensor nodes.

Kumar *et al.* [44] proposed a protocol EEHC (Energy Efficient heterogeneous clustered scheme for WSN) that aims at increasing the stability and network lifetime in presence of heterogeneous nodes. Nodes in the network are divided into three categories: normal nodes, advanced nodes and super nodes which are referred to as heterogeneous nodes. In this it is assumed that energy of advanced nodes is  $\alpha$  time more than energy of normal nodes and energy of super nodes is  $\beta$  times more than energy of normal nodes. In this protocol the lifetime and performance of network is improved by using weighted probability of election of CH.

Balamurugan *et al.* [45] proposed a Fitness Based Routing Protocol for the optimization of energy efficient data transmission so as to increase the network lifetime. In this reduction in consumption of energy by the nodes is done by selecting the nodes with minimum hop count and distance. Fitness value of nodes is calculated to find the fittest node. Fitness value of the node is computed on the basis of distance between node and the base station. In this scheme there was considerable increase in the throughput, reduction in end to end delay and minimized the packet loss.

Liu *et al.* [46] proposed a protocol LEACH-GA which consists of setup phase and steady state phase for each round with an additional phase named preparation phase before the beginning of the first round. The preparation phase is followed once only before the first round and setup phase and steady state phase are followed in same way as in LEACH in all other rounds. In preparation phase CH selection procedure is followed by the nodes by sending messages to BS such as their status of being CH or not, its node id and its distance from BS. After receiving the messages from the nodes, the BS computes the optimal probability of node by using Genetic Algorithm to become CH. Then the BS sends the values of computed optimal probability values to all the nodes so as to form clusters during the setup phase. The scheme improves the lifetime of the network.

Lee *et al.* [47] proposed a protocol to balance the clusters by considering the importance of selection of cluster head in the network. In this scheme the sensor nodes are partitioned into two layers and CH selection is done based on the distance between nodes and base

station. Each layer is sequenced according to the distance between nodes and BS. Second layer is the sub layer of the first layer. Without communicating with other nodes the selection of CH is made in the same sequence of second layer.

Gupta *et al.* [48] proposed a protocol named ACO LEACH in which selection of cluster head is based on the swarm intelligence. The base protocol used in this LEACH. For an effective CH selection residual energy is used as a parameter in the ant colony optimization. The amount of energy consumption is reduced in this protocol. This scheme follows three stages. In the first stage nodes transmit data to their cluster heads, then in second stage data is transmitted by the CH to its leader and in the end the whole received data is forwarded by leader to the BS. The average energy consumption is significantly reduced in this scheme.

## 2.4 Comparison of the routing protocols

Table 2.1 Comparison of hierarchical routing protocols of WSN

<b>Protocols</b>	<b>Cluster Method</b>	<b>Node Mobility</b>	<b>Energy Dissipation</b>	<b>CH selection</b>	<b>Topology</b>	<b>CH distribution</b>
<b>LEACH</b>	Distributed	Fixed BS	Unbalanced	Random	Singlehop	Poor
<b>IBLEACH</b>	Distributed	Fixed BS	Balanced	Random	Multihop	Good
<b>CCM</b>	Distributed	Fixed BS	Balanced	On basis of residual energy	Multihop	Good
<b>DAIC</b>	Distributed	Fixed BS	Balanced	On basis of alive nodes	Multihop	Good
<b>ECLEACH</b>	Centralized	Fixed BS	Balanced	On basis of residual energy and MDBECHAN	Singlehop	Good
<b>GSTEB</b>	Centralized	Stationary	Balanced	On basis of residual energy	Multihop	Good
<b>EEHC</b>	Distributed	Stationary	Balanced	On basis of computed Optimal probability	Multihop	Good

<b>MOECS</b>	Distributed	Fixed BS	Balanced	Random	Singlehop	Good
<b>TEEN</b>	Distributed	Fixed BS	Balanced	Random	Singlehop	Good
<b>APTEEN</b>	Distributed	Fixed BS	Balanced	Random	Singlehop	Good
<b>PEGASIS</b>	Distributed	Fixed BS	Balanced	Random	Multihop	Good
<b>ACO LEACH</b>	Distributed	Fixed BS	Balanced	On basis of residual energy	Multihop	Good
<b>LEACH-GA</b>	Distributed	Fixed BS	Balanced	On basis of distance from BS	Singlehop	Good
<b>Two layer LEACH</b>	Distributed	Fixed BS	Balanced	On basis of distance from BS	Multihop	Good

Table 2.2 Comparison of routing protocols based on location awareness and network distribution

<b>Protocols</b>	<b>Location awareness</b>	<b>Tiers Formation in Network</b>	<b>Chain Formation</b>
<b>LEACH</b>	x	x	x
<b>IBLEACH</b>	x	x	x
<b>CCM</b>	x	x	✓
<b>DAIC</b>	✓	✓	x
<b>ECLEACH</b>	✓	x	x
<b>GSTEB</b>	✓	x	x
<b>EEHC</b>	x	x	x
<b>MOECS</b>	x	x	x
<b>TEEN</b>	x	x	x
<b>APTEEN</b>	x	x	x
<b>PEGASIS</b>	x	x	✓
<b>LEACH-GA</b>	✓	x	x
<b>Two layer LEACH</b>	✓	✓	x
<b>LEACH-MA</b>	✓	x	x

## CHAPTER 3

### PROBLEM STATEMENT

---

In LEACH there is random selection of CH based on the probability and it doesn't consider the distance between CH and BS and residual energies of the node to be selected as CH. So this proves to be the drawbacks of LEACH. During random selection of CH there the case arises in which the CH is very far away from BS and which degrades the energy of CH significantly. So for clustering to be efficient the good CH selection procedure needs to be used. Also if the transmission distance between the CH and BS is high then it may result into early degradation of energy of CH. Therefore new scheme need to be proposed which would improve CH selection procedure and can help in reducing the energy degradation of CH. The proposed scheme in this thesis introduces GADA-LEACH in which the CH selection method is improved and relay node concept is introduced. For improving the CH selection procedure, Genetic Algorithm is used. In this fitness function is computed by using parameters such as energy of all nodes, energy of cluster heads, distance of CH with its associated nodes, number of nodes in cluster, distance of BS from all CH's and number of CH's formed. Relay node is deployed at the centre of the network. It is rechargeable node. It makes the communication between the BS and CH easy by acting as intermediate between the both.

### 3.1 Objectives

The main goal is to provide an energy efficient solution to enhance the lifetime of the network. To accomplish the goal following objectives are considered:

- To study and simulate LEACH protocol in MATLAB.
- To analyze limitations in LEACH.
- To modify protocol CH selection procedure using Genetic algorithm.
- Enhancing the network stability by introducing relay nodes communication.
- Enhancing the lifetime of the network using GADA-LEACH than the traditional protocols (LEACH, LEACH-E and LEACH-EX)

### SIMULATOR INTRODUCTION (MATLAB)

---

#### 4.1 Simulator Introduction (MATLAB)

In the project simulation tool used is MATLAB [49] which is a high-level language and interactive environment for numerical computation, visualization, and programming. MATLAB stands for matrix laboratory. The software finds its extensive use in all areas of applied mathematics, education and in universities and industry for the research purposes. It is developed around vectors and matrices which make the software extremely useful for linear algebra but it is also a significant tool for resolving algebraic and differential equations and for numerical integration. MATLAB has good graphic tools and graphs can be plotted in both 2D and 3D. For writing mathematical programs it is very easiest programming language which can be used. It also has useful tool boxes for signal processing, image processing, optimization, etc. One of the disadvantages of MATLAB is that it is very slow and poor programming practices can too make it significantly slower. It is feasible to share the work with the help of MATLAB. Applications and algorithm developed in MATLAB can be distributed as a stand-alone executables, components for merging in other software environments for example excel. C code can also be imported within MATLAB. One million people all over the world are taking advantage of MATLAB. With MATLAB it is possible to create two types of program files. They are scripts and functions. Scripts are the program files saves with .m extension. Whatever commands written in script file is executed. Scripts neither take inputs from users nor return any output. Functions are MATLAB editor allows writing scripts or functions to be executed.

A desktop is the main working window of MATLAB which is shown in figure 4.1. It has further 4 panels:

- Command window: This window is prompted by >>. In this the user types in commands that need to be executed.
- Current folder: With the help of this panel user can have access to the current folders and files of the project.

- Command history: This panel consists of the details about commands executed in past.
- Workspace: This panel contains the details about the created variables in the programs or variables that may be imported from other programs.

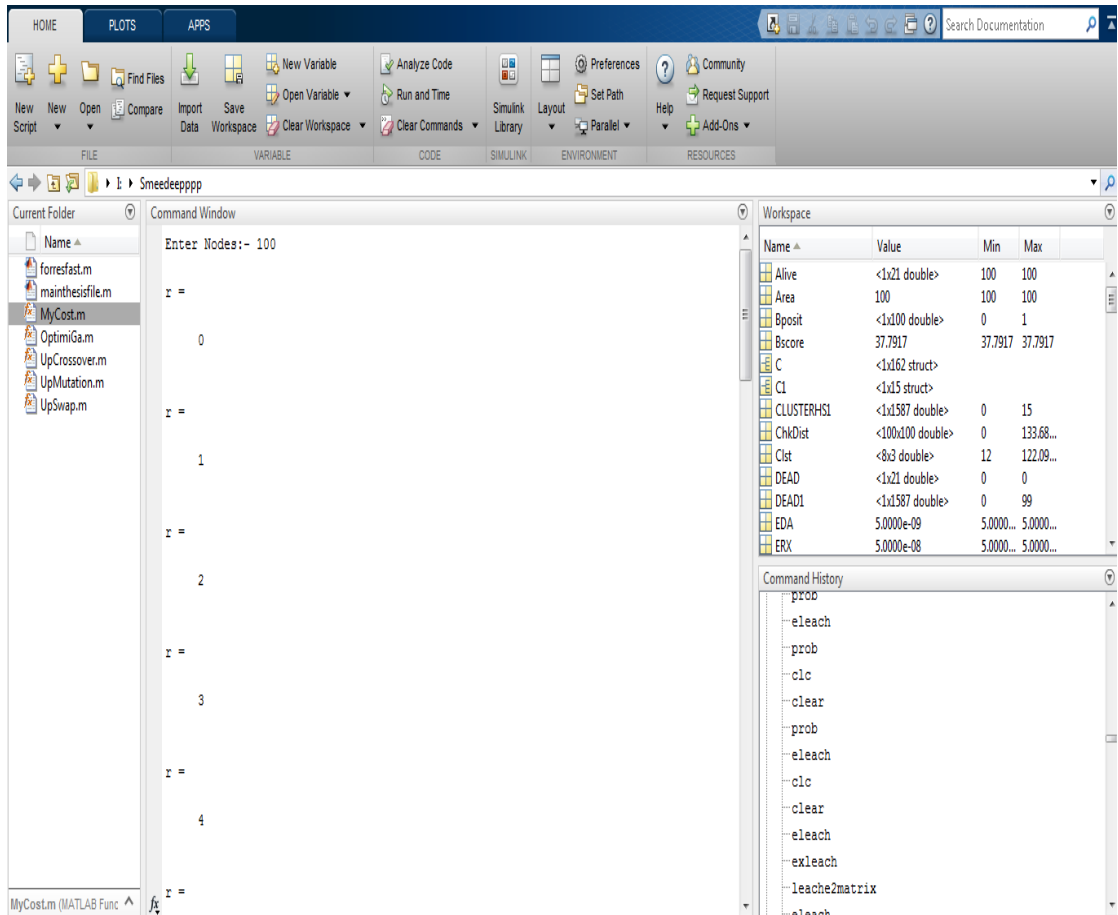

Figure 4.1: Desktop view of MATLAB

# CHAPTER 5

## PROPOSED ALGORITHM

---

---

### 5.1 Assumptions

For obtaining an optimized approach of Cluster Head selection in the network, following assumptions are made:

- The Base station is situated outside the network.
- The relay nodes in the network are rechargeable.

### 5.2 Proposed Work

In the protocols designed till date, the cluster head selection was random based on the probability equation. The probability equation was applied on the nodes and then the cluster heads were selected randomly. The overall performance of the network needs to be improved by improving the parameters such as the energy parameters, distance between nodes and cluster heads and the distance between cluster heads. The researches conducted till now consider only some of the parameter for increasing the efficiency of the network. In recent research trail the sink was located out of the network, which increased the distance between the sink and the cluster head, which resulted in early degradation of the energy of the nodes, and in turn decreased network lifetime. In the proposed work, a relay node is introduced between the sink and the cluster head, the cluster head first transfers the information to the relay node and then the relay node further transfers it to the sink. The relay node helped to ease the communication between the cluster head and sink, so the energy efficiency is improved by introduction of the relay node. This introduced relay node is rechargeable. The second proposal given in this new approach is change in the criteria of selection of cluster head. Earlier cluster heads were selected randomly using probability equation, but in this proposed scheme the selection of cluster head is based on the Genetic Algorithm. In this the iteration count of the CHs is done and then each nodes probability to be a cluster head is seen and the best suited node to be a cluster head is then chosen as cluster head of that round. The overall performance of the network depends on the energy of the node, the distance between the

node and the cluster head and the distance between the cluster head and the sink. These factors together contribute for the better efficiency of the network. This proposed scheme is better and efficient than the conventional techniques as all the performance parameters are considered while deciding the cluster head and a better technique is obtained.

### 5.3 Proposed Algorithm

The proposed algorithm is based on GA and uses fitness function consisting of parameters such as energy of all nodes, energy of cluster heads, distance of CH with its associated nodes, number of nodes in cluster, distance of BS from all CH's and number of CH's formed while deciding the cluster head in the network. The entire flow of GADA LEACH is shown in Fig 5.1. The steps of the proposed algorithm are described below:

1. The parameters on which the network performance depends are to be initialized in the first step.
2. Then the second step will be the allotment of the energy parameters. All the parameters will be initialized in the first step itself so in this step only the energy parameters are allotted.
3. The initial population for the cluster head selection is to be generated. The cluster heads are selected from some number of nodes present in the network so in this step we generate initial population for the selection of cluster head.
4. The fitness is then evaluated. In this step after the generation of initial population, the fitness of each node is evaluated for the better results and so that the best of the node can be selected as cluster head.

Fitness function used is as follows:

$$\text{fitness function} = [(0.3 * f1) + (0.35 * f2) + (0.35 * f3)]$$

$$f1 = \frac{\text{Energy of all nodes}}{\text{Energy of Cluster heads}}$$

$$f2 = \frac{\text{Distance of CH with its associated nodes}}{\text{Number of nodes in cluster}}$$

$$f3 = \frac{\text{Distance of BS from all CH's}}{\text{number of CH's formed}}$$

5. From the fitness evaluated, the best fitness is chosen and it is then stated as the initial fitness.
6. The population selected earlier and of which the fitness is calculated is then updated using genetic algorithm.
7. After applying GA, the fitness of the population is evaluated again and is then compared with the initial one.
8. If the upgraded fitness of the population is greater than the initial population then this new updated fitness is considered and the process moves on to the next iteration. The best node for that round will be chosen as the cluster head.
9. After deciding the cluster head, now communication will be setup between cluster head and nodes and the cluster head and the sink. Final communication among nodes, cluster head and base station will be set introducing relay node. This relay node will be introduced between sink and the cluster head, the cluster head will not directly communicate with the sink, it will first transmit the information to the relay node and the relay node will further communicate with the sink.
10. After this the final calculation of parameters will be done.
11. Now, if the upgraded fitness is lesser than the initial population, then the population will be again updated using genetic algorithm, then again the fitness of the new updated population is evaluated and compared with the initial population's fitness. This step is repeated until the fitness of updated population becomes greater than the fitness of the initial population. Once the fitness of the updated population becomes greater, the process moves to the next iteration and a final communication is set up between the cluster head and the sink.

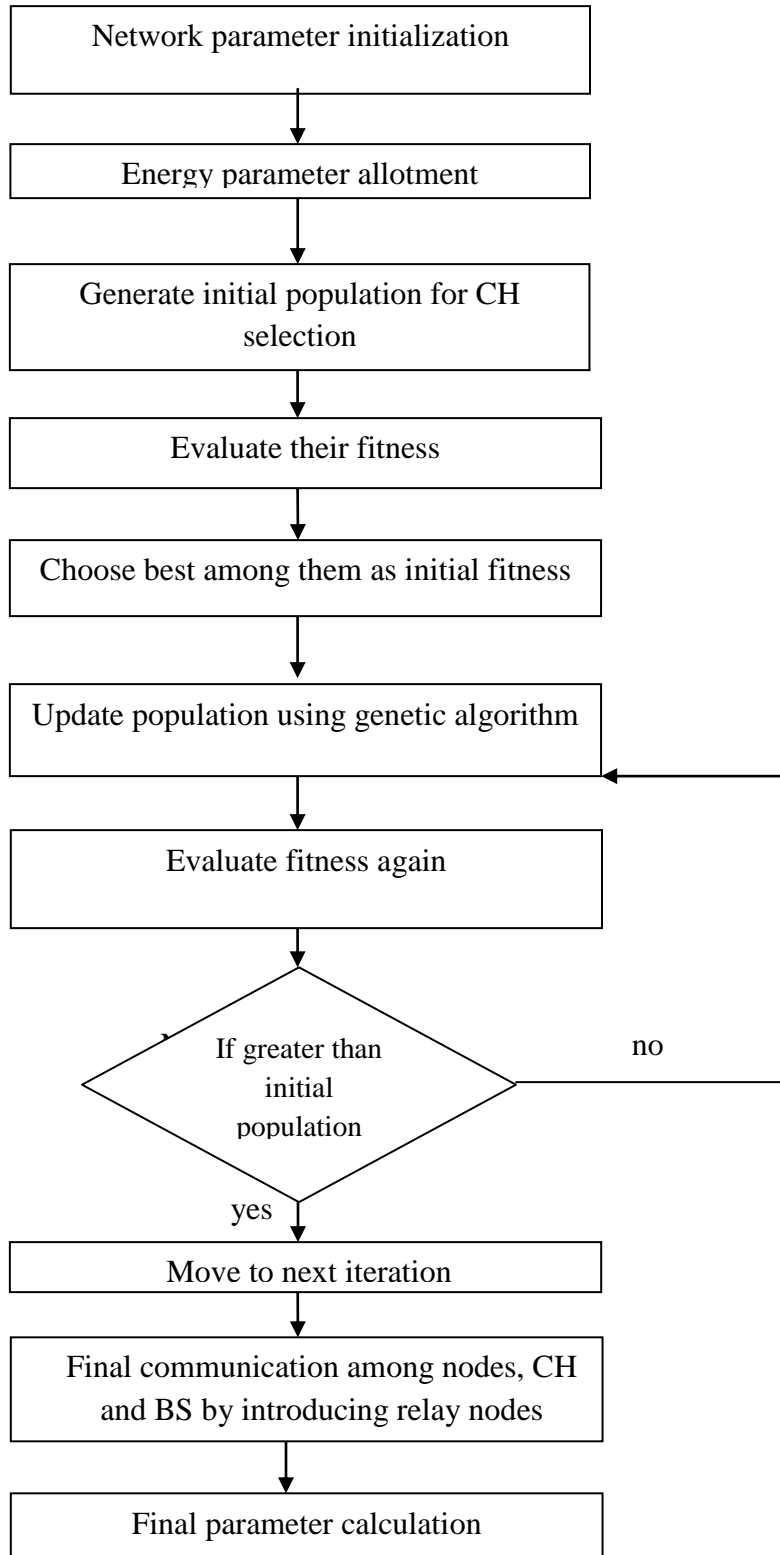

Figure 5.1 Flowchart of GADA-LEACH

**SIMULATION RESULTS AND DISCUSSIONS**

---

**6.1 Simulation Environment**

The proposed algorithm has been designed in MATLAB. In this random distribution of 100 nodes is done in area of 100 X 100 m<sup>2</sup>. Implementation consists of selection of cluster heads on the basis of Genetic Algorithm optimization technique and then formation of clusters is done. A relay node is deployed at the centre of the network. Cluster heads calculate the distance from the Base station and distance from the relay node and the aggregated data is sent to the either which has the shortest distance from it. So by the use of concept of relay nodes the energy consumption of the cluster heads is decreased and hence the network lifetime increases with this scheme. The proposed scheme thus is efficient in both cluster head selection and the routing of data from cluster head to the base station.

Evaluation is done based upon following metrics:

- Network Lifetime
- Packets Delivered to Base Station

Simulator parameters are mentioned in table 6.1.

Table 6.1: Simulation Parameters

<b>Network parameters</b>	<b>Values</b>
Network Size	100X100m <sup>2</sup>
Number of nodes	100
Packet Size	4000 bits
Routing Protocol	LEACH,ELEACH, EXLEACH, GADA LEACH
Initial energy of node	0.5 J/node
Energy to run transmitter and receiver	50 nJ/bit
Data aggregation energy	50 nJ/bit

Amplification Energy (Efs)	10 pJ/bit/m <sup>2</sup>
Amplification Energy (Emp)	0.0013 pJ/bit/m <sup>2</sup>
Primary population	100
Crossover rate	0.4
Mutation rate	0.006
Selection method	roulette wheel selection

## 6.2 Simulation Results

### 6.2.1 Network Structure of GADA-LEACH

In GADA-LEACH the BS is situated outside the network and relay node is introduced inside at the centre of the network. The purpose of using relay node is to decrease the energy degradation of cluster head while sending the aggregated data to BS. CH sends data to BS through relay node when its distance from relay node is lesser than its distance from the BS. The energy of relay node is higher than cluster heads and lesser than BS and they are assumed to be rechargeable. By the use of relay nodes the lesser energy of cluster heads is used and so the results obtained are better. Network Structure of GADA-LEACH is shown below in fig 6.1. The blue node at centre is relay node and the node represented with (x) is the BS. Nodes numbered from 1 to 100 are the sensor nodes.

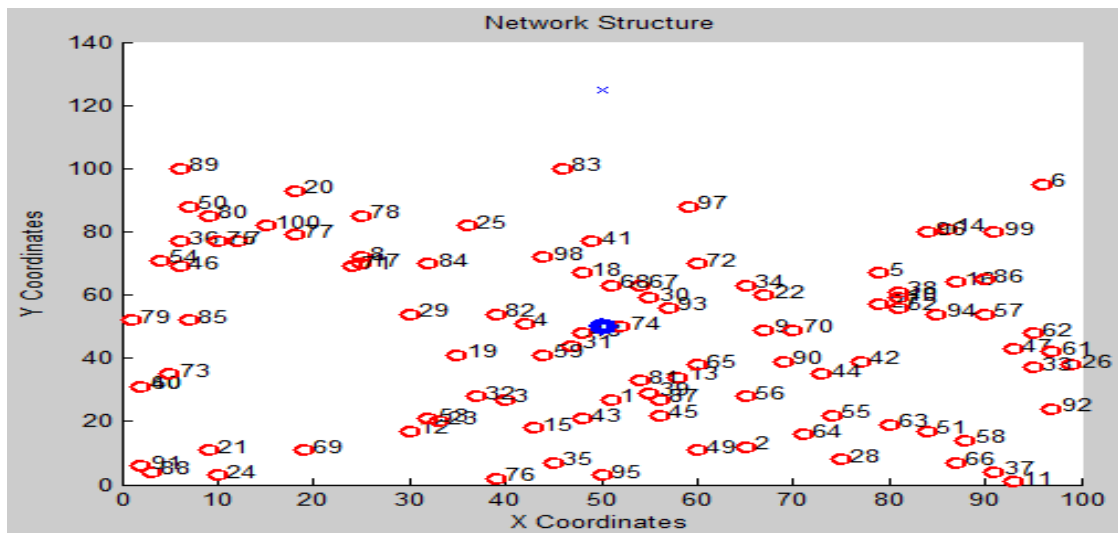

Figure 6.1 Network Structure of GADA LEACH

## 6.2.2 Comparison of Network Lifetime with varying initial energy

- **When Initial Energy = 0.3**

In fig. 6.2 in case of LEACH, LEACH-E, LEACH-EX and GADA-LEACH the first node dies at different round. The first node died at round 400, 437, 449 and 1080 in LEACH, LEACH-E, LEACH-EX and GADA-LEACH respectively. Lifetime refers to the time when first node dies. So lifetime of network is highest in case of GADA-LEACH followed by LEACH-EX, LEACH-E and LEACH.

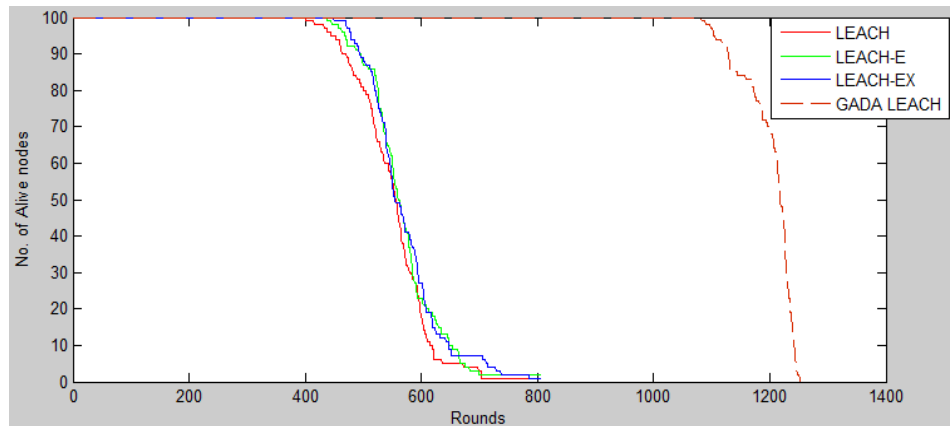

Figure 6.2 Plot of comparison of network lifetime LEACH, LEACH-E, LEACH-EX and GADA-LEACH at  $E_o = 0.3$

- **When Initial Energy=0.4**

In fig. 6.3, in case of LEACH, LEACH-E, LEACH-EX and GADA-LEACH the first node dies at different round. The first node died at round 564, 589, 598 and 1441 in LEACH, LEACH-E, LEACH-EX and GADA-LEACH respectively. So lifetime of network is highest in case of GADA-LEACH followed by LEACH-EX, LEACH-E and LEACH.

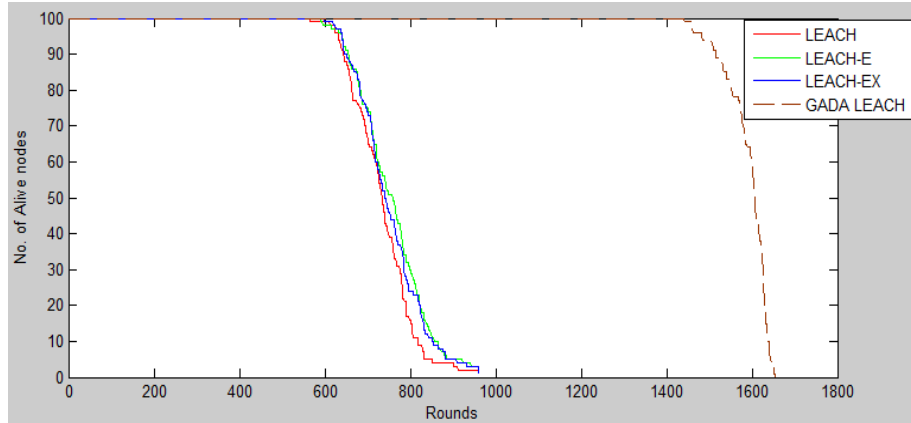

Figure 6.3 Plot of comparison of network lifetime LEACH, LEACH-E, LEACH-EX and GADA-LEACH at  $E_o=0.4$

- **When initial energy=0.5**

In fig. 6.4, in case of LEACH, LEACH-E, LEACH-EX and GADA-LEACH the first node dies at different rounds. The first node died at round 710, 727, 765 and 1778 in LEACH, LEACH-E, LEACH-EX and GADA-LEACH respectively. So lifetime of network is highest in case of GADA-LEACH followed by LEACH-EX, LEACH-E and LEACH.

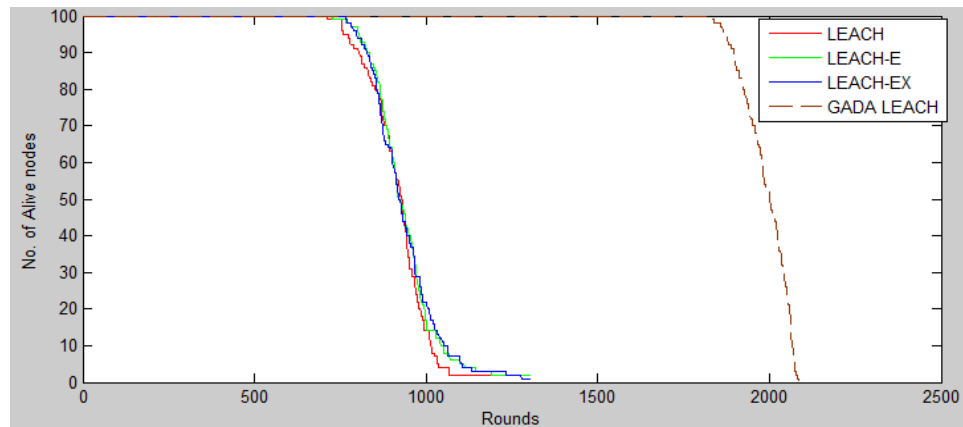

Figure 6.4 Plot of comparison of network lifetime LEACH, LEACH-E, LEACH-EX and GADA-LEACH at  $E_o = 0.4$

So from above observations it can be concluded in fig. 6.5 that higher the value of initial energy is higher will be the network lifetime.

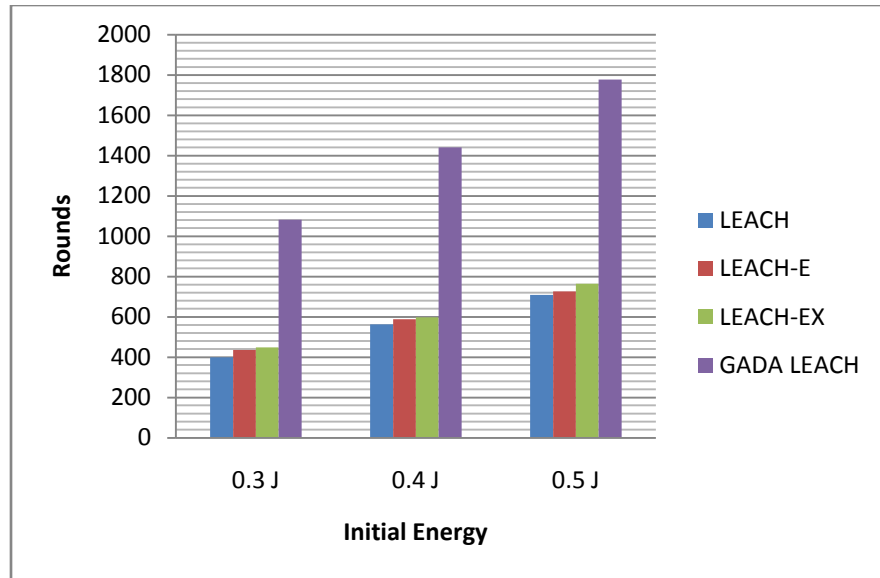

Figure 6.5 Network Lifetime of LEACH, LEACH-E, LEACH-EX and GADA-LEACH when varying  $E_0$

### 6.2.3 Comparison of Network Lifetime with varying packet size

- When packet size=2000

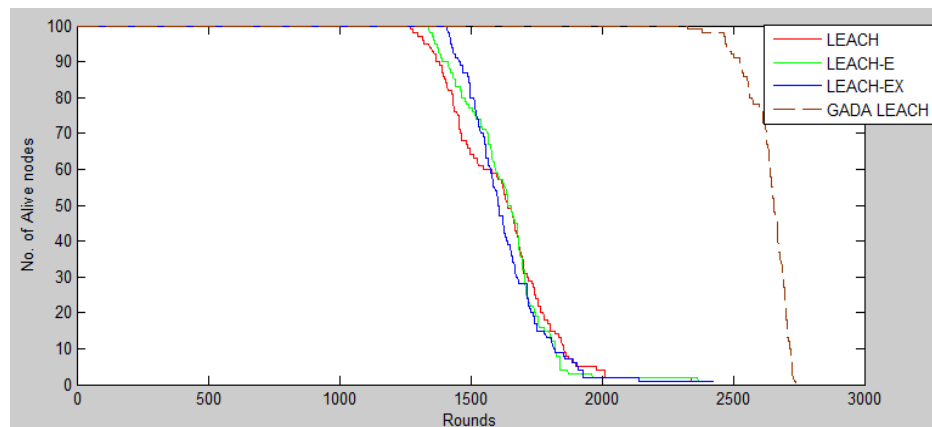

Figure 6.6 Plot of comparison of network lifetime LEACH, LEACH-E, LEACH-EX and GADA-LEACH when packet size=2000

In fig. 6.6, in case of LEACH, LEACH-E, LEACH-EX and GADA-LEACH the first node dies at different round. The first node died at round 1270, 1341, 1409 and 2325 in LEACH, LEACH-E, LEACH-EX and

GADA-LEACH respectively. So lifetime of network is highest in case of GADA-LEACH followed by LEACH-EX, LEACH-E and LEACH.

- **When packet size=3000**

In fig. 6.7, in case of LEACH, LEACH-E, LEACH-EX and GADA-LEACH the first node dies at different round. The first node died at round 915, 966, 992 and 1839 in LEACH, LEACH-E, LEACH-EX and GADA-LEACH respectively. So lifetime of network is highest in case of GADA-LEACH followed by of LEACH-EX, LEACH-E and LEACH.

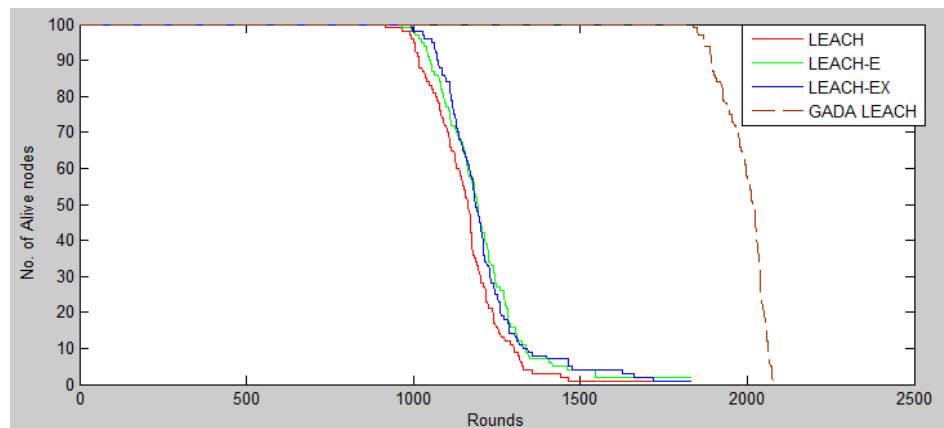

Figure 6.7 Plot of comparison of network lifetime LEACH, LEACH-E, LEACH-EX and GADA-LEACH when packet size=3000

- **When packet size=4000**

In fig. 6.8, in case of LEACH, LEACH-E, LEACH-EX and GADA-LEACH the first node dies at different round. The first node died at round 710, 727, 765 and 1720 in LEACH, LEACH-E, LEACH-EX and GADA-LEACH respectively. So lifetime of network is highest in case of GADA-LEACH followed by LEACH-EX, LEACH-E and LEACH.

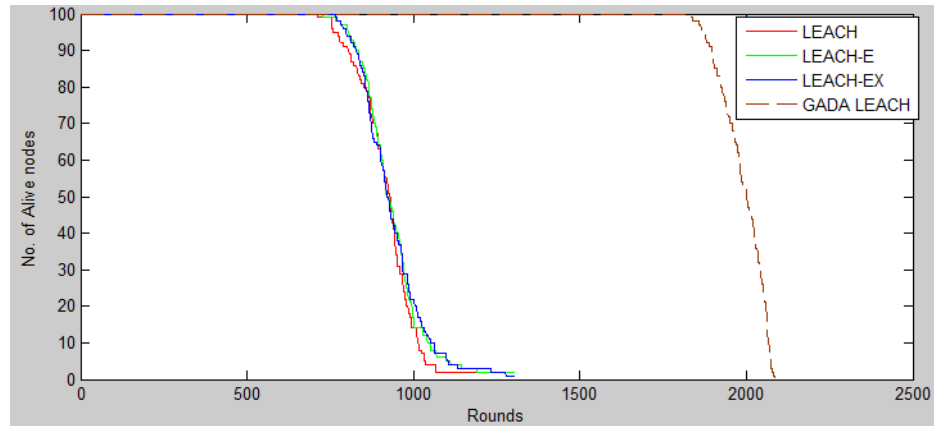

Figure 6.8 Plot of comparison of network lifetime LEACH, LEACH-E, LEACH-EX and GADA-LEACH when packet size=4000

So from above observations it can be concluded in fig. 6.9 that size of packet to be transmitted has effect on the network lifetime in WSN. Higher the size of the packet higher is the consumption of the energy.

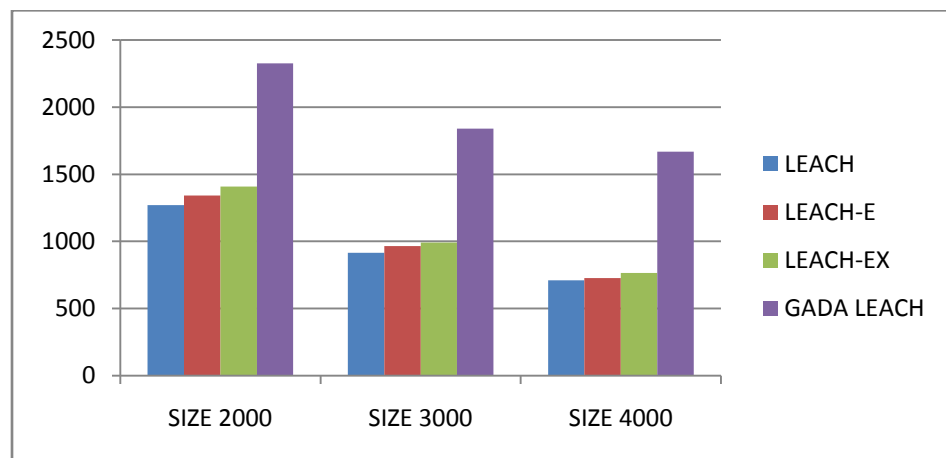

Figure 6.9 Network Lifetime LEACH, LEACH-E, LEACH-EX and GADA-LEACH when varying packet size

#### 6.2.4 Comparison of Packets Delivered to Base Station

Fig 6.10, 6.11, 6.12 and 6.13 shows the number of packets sent to the base station in LEACH, LEACH-E, LEACH-EX and GADA-LEACH. GADA-LEACH runs for more number of rounds than other protocols so the number of packets sent to BS is more followed by LEACH-EX, LEACH-E and LEACH.

Packets to BS will be sent till round 700 in LEACH, 800 in LEACH-E, 900 in LEACH-EX and 1600 in GADA-LEACH which shows that due to having more network stability it runs for more number of rounds and more number of packets is sent to BS in GADA-LEACH and shows significant improvement.

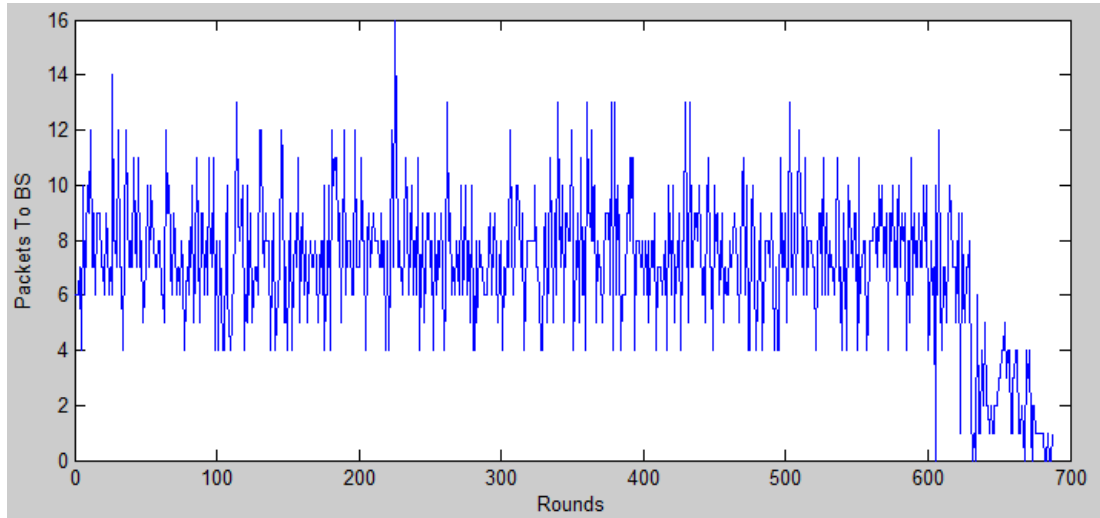

Figure 6.10 Packets Delivered to Base Station in LEACH

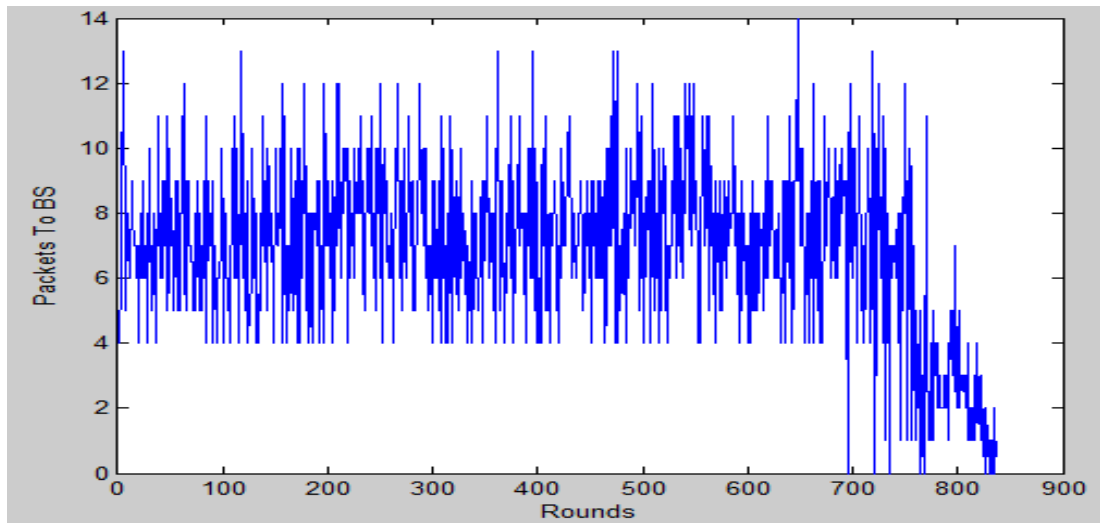

Figure 6.11 Packets Delivered to Base Station in LEACH-E

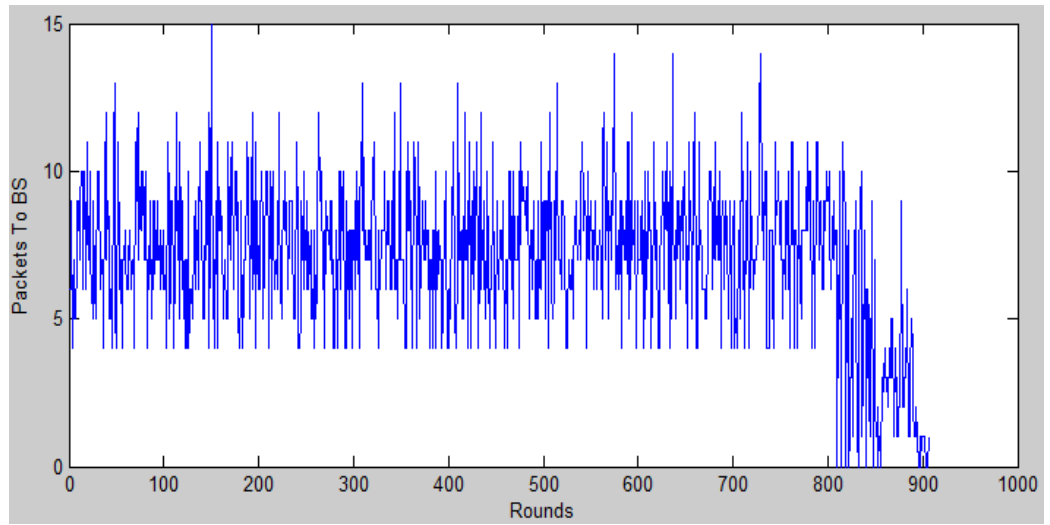

Figure 6.12 Packets Delivered to Base Station in LEACH-EX

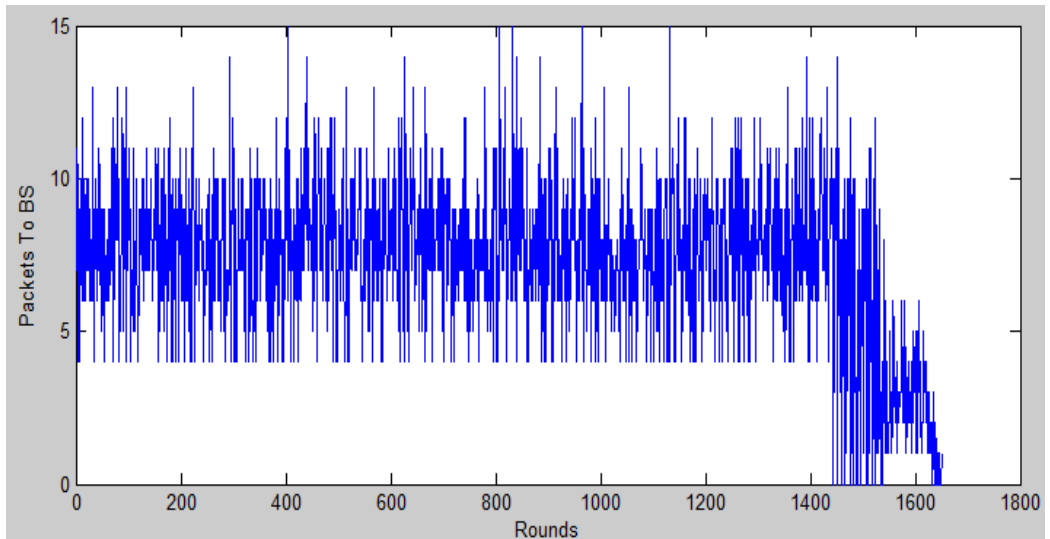

Figure 6.13 Packets Delivered to Base Station in GADA-LEACH

#### 7.1 Conclusion

In this thesis an optimized scheme with CH selection based on Genetic Algorithm is proposed. Network lifetime of proposed scheme GADA-LEACH is compared with LEACH, LEACH-E and LEACH-EX by varying the initial energy and size of the packet. GADA-LEACH proves to perform better by providing improved results in comparison. The first node died at 1778<sup>th</sup> round in GADA-LEACH whereas first node died at 710<sup>th</sup>, 727<sup>th</sup>, 765<sup>th</sup> round in LEACH, LEACH-E and LEACH-Ex respectively.

Due to improved CH selection and introduction of relay node in the network the data sent to the BS is more as there is increase in network stability. It can be concluded that the introduced approach is better and efficient than the conventional approaches as it includes more number of parameters in fitness function for selecting the cluster head and also introduction of intermediate node i.e. relay node reduces the distance between the cluster head and sink and to ease the communication between them.

#### 7.2 Future Scope

In this scheme, it is proposed to introduce a relay node as an intermediate node between cluster head and sink that helped to increase energy efficiency which in turn improved the network lifetime. Cluster head selection procedure is improved by using GA. Further the improvements can be made in the scheme by using sleep and awake concept. In this concept all the nodes do not remain active throughout. The energy of the nodes will be calculated and the node having highest energy will be awake and the rest of the nodes will be considered sleeping i.e. there will be no movement in them. This concept of sleep and awake nodes will also enhance the energy of the system and will increase network lifetime. Further enhancements can be done by using other swarm intelligence optimization techniques for getting more optimized results. Still number of improvements can be made in the proposed scheme and better results can be obtained.

## REFERENCES

---

- [1] Akyildiz, I. F., Su, W., Sankarasubramaniam, Y. and Cayirci, E, “A survey on sensor networks”. *IEEE Communications Magazine*, 40(8), pp. 102-114, 2002.
- [2] Al-Karaki, J.N. and Kamal, A.E, “Routing techniques in wireless sensor networks: A survey”. *IEEE Wireless Communications*, 11(6), pp. 6-28, 2004.
- [3] Pottle, G.J. and Kaiser, W.J, “Embedding the internet: Wireless integrated networks sensors”. *Communications of the ACM*, 43(5), pp. 51-58, 2000.
- [4] Khedr, A. M., Osamy, W., and Agrawal, D.P, “Perimeter discovery in wireless sensor networks. *Journal of Parallel and Distributed Computing*, 69, pp. 922-929, 2009.
- [5] Broch, J., Maltz, D., Johnson, D., Hu, Y. and J. Jetcheva, “A Performance Comparison of Multihop Wireless Ad Hoc Network Routing Protocols”. *In Proceedings of the 4th Annual ACM/IEEE International Conference on Mobile Computing and Networking (MOBICOM)*, ACM, 1998.
- [6] Royer, E. M. and Toh, C. K, “A Review of Current Routing Protocols for Ad-Hoc Mobile Wireless Networks”. *IEEE Personal Communications Magazine*, April 1999, pp. 46-55,1999.
- [7] Ibrahim, A, “Integrated Comparison of Energy Efficient Routing Protocols in Wireless Sensor Network: A Survey”, *Business, Engineering and Industrial Applications (ISBEIA)*, pp. 237-242, 2011.
- [8] Rahman, M.A, “A Survey on Energy Efficient Routing Techniques in Wireless Sensor Network”, *in Advanced Communication Technology (ICACT), 15th International Conference*, pp. 200-205, 2013.
- [9] Soua, R, “A Survey on Energy Efficient Techniques in Wireless Sensor Networks”, *Wireless and Mobile Networking Conference (WMNC), 4<sup>th</sup> Joint IFIP*, 2011, pp. 1-9, 2011.
- [10] Ahlawat, A, “An Extended Vice-Cluster Selection Approach to Improve V Leach Protocol in WSN”, *Third International Conference Advanced Computing and Communication Technologies (ACCT)*, 2013, pp. 236-240, 2013.

- [11] Naregal, K, “Improved Cluster Routing Protocol for Wireless Sensor Network through Simplification”, 18th Annual International Conference *Advanced Computing and Communications (ADCOM'12)*, pp. 1-3, 2012.
- [12] Yuling Li, “The Improvement of LEACH Protocol in WSN”, Computer Science and Network Technology (ICCSNT), pp. 1345-1348, 2011.
- [13] Aliouat, Z, “An Efficient Clustering Protocol Increasing Wireless Sensor Networks Life Time”, Innovations in Information Technology (IIT), pp. 194-199, 2012.
- [14] Mahajan, L, “Improving the Stable Period of WSN using Dynamic Stable Leach Election Protocol”, Issues and Challenges in Intelligent Computing Techniques (ICICT), pp. 393-400, 2014.
- [15] Pantazis, N.A, “Energy-Efficient Routing Protocols in Wireless Sensor Networks: A Survey”, Communications Surveys & Tutorials, IEEE, 15(2), pp. 551-591, 2013.
- [16] Said, B. and Abdellah, E, “Improved and balanced LEACH for heterogeneous wireless sensor networks” *Information Fusion*, pp. 220-222, 2010.
- [17] AbuBakr, B. and Lilien, L, “Extending Wireless sensor network lifetime in the LEACH-SM protocol by spare selection”, *In Proceedings of the fifth international conference on innovative mobile and internet services in ubiquitous computing (IMIS '11)*, Washington, DC, USA: IEEE Computer Society, pp. 277-282, 2011.
- [18] Tang and Feilong, “A chain-cluster based routing algorithm for wireless sensor networks”, *Journal of intelligent manufacturing*, pp. 1305-1313, 2012.
- [19] Heinzelman, W.R., Chandrakasan, A. and Balakrishnan, H, “LEACH: Energy efficient communication protocol for wireless microsensor networks”, *In proceedings of Hawaii International Conference on System sciences*, Maui, Hawaii, pp. 3005-3014, 2000.
- [20] Lindsey, S., Raghavendra C. S. and Sivalingam K, “Data gathering in sensor networks using the energy\*delay metric”, *In Proceedings of the IPDPS Workshop on Issues in Wireless Networks and Mobile Computing*, San Francisco, USA, pp. 188, 2001.
- [21] Aslam and Nauman, “A multi-criterion optimization technique for energy efficient cluster formation in wireless sensor networks”, *Information Fusion*, pp. 202-212, 2011.

- [22] Hienzelman, W.B, “An application-specific protocol architecture for wireless microsensor networks”, *IEEE Transactions on Wireless Communications*, pp. 660-670, 2002.
- [23] Ye, M., Li, C.F., Chen, G.N., Wu, J, “EECS: an energy efficient clustering scheme in WSN”, In *IEEE International Performance Computing and Communications Conference (IPCCC)*, pp.535-540, 2005.
- [24] Stadler, W, “Multicriteria Optimization in Engineering and in the Sciences”, *Springer*, 1988.
- [25] Barzilai, J, “Measurement foundations for preference function modeling”, In *IEEE International Conference on Systems, Man, and Cybernetics*, vol.4, 1998.
- [26] Goodridge, W., Robertson, W., Phillips, W.J., and Sivakumar, S, “Heuristic constraint-path routing decision system”, In *Proceedings of the 3rd Annual Communication Networks and Services Research Conference (CNSR '05)*, vol. 01, pp. 3-8, 2005.
- [27] Manjeshwar, A. and Agrawal, D. P, “TEEN: a routing protocol for enhanced efficiency in wireless sensor networks”, *IEEE Computer Society International Symposium on Parallel and Distributed Processing*, 3, p. 30189a, 2001.
- [28] Manjeshwar, A. and Agrawal, D. P, “APTEEN: A hybrid protocol for efficient routing and comprehensive information retrieval in wireless sensor networks”, *Parallel and Distributed Processing Symposium, International, IEEE Computer Society*, 2, p. 0195b, 2002.
- [29] Bonnet, P., Gehrke, J. and Seshadri, P, “Querying the Physical World”, In *IEEE Personal Communications Special Issue on Smart Spaces and Environments*, 7(5), 10-15, 2000.
- [30] Bonnet, P., Gehrke, J. and Seshadri, P, “Towards Sensor Database Systems”, In *2nd International Conference on Mobile Data Management*, pp. 3-14, 2001.
- [31] Gautam, N. and Jae-Young, P, “Distance aware intelligent clustering protocol for wireless sensor networks”, *Journal of Communications and Networks*, 12(2), pp. 122-129, 2010.

- [32] Xiangning, F. and Yulin, S, “Improvement on LEACH protocol of wireless sensor network”, *In Proc. Int. Conf. Sensor Technologies and Applications*, pp. 260-264, 2007.
- [33] Zheng, G. and Zhou, Y, “An energy-aware cluster protocol for wireless sensor networks”, *In Proc. Int. Conf. Innovative Computing, Information and Control*, pp. 472-473, 2007.
- [34] Lee, S., Lee, J., Sin, H., Yoo, S., Lee, J. and Lee, Y, “An energy-efficient distributed unequal clustering protocol for wireless sensor networks”, *In Proc. MProc. WASET*, 48, pp. 443-447, 2009.
- [35] Bsoul, M, “An energy-efficient threshold-based clustering protocol for wireless sensor networks”, *Wireless personal communications*, pp. 99-112, 2013.
- [36] Sohraby, K., Minoli, D. and Znati, T, “Wireless sensor networks: Technology, protocols, and applications”, Wiley, 2007.
- [37] Debroy, B., Sadi, M. and Imran, M, “An efficient approach to select cluster head in wireless sensor networks”, *Journal of Communications*, 6(7), pp. 529-539, 2011.
- [38] Fazackerley, S., Paeth, A., and Lawrence, R, “Cluster head selection using RF signal strength”, *In Canadian conference on electrical and computer engineering*, Canada: Newfoundland and Labrador, pp. 334-338, 2009.
- [39] Gao, T., Jin, R., Song, J., Xu, T., and Wang, L, “Energy efficient cluster head selection scheme based on multiple criteria decision making for wireless sensor networks”, *Wireless Personal Communications*, 63(4), pp. 871-894, 2012.
- [40] Gupta, I., Riordan, D. and Sampalli, S, “Cluster-head election using fuzzy logic for wireless sensor networks”, *In Proceedings of the 3<sup>rd</sup> annual communication networks and services research conference* , Washington, DC, pp. 255-260, 2005.
- [41] Han, Z, “A General Self-Organized Tree-Based Energy-Balance Routing Protocol for Wireless Sensor Network”, *Nuclear Science, IEEE Transactions on*, 61(2), pp. 732-740, 2014.
- [42] Szewczyk, R., Polastre, J., Mainwaring, A. and Culler, D, “Lessons from sensor network expedition”, *In Proceedings of the 1<sup>st</sup> European Workshop on wireless sensor networks EWSN '04*, Germany, pp. 307-322, 2004.

- [43] Lindsey, S. and Cauligi, S. R, "PEGASIS: Power-efficient gathering in sensor information systems", *Aerospace conference proceedings*, Vol. 3, pp. 3-1125, 2002.
- [44] Kumar, D., Trilok, C. A. and Patel, R.B, "EEHC: Energy efficient heterogeneous clustered scheme for wireless sensor networks", *Computer Communications*, pp. 662-667, 2009.
- [45] Balamurugan, A, "An Energy Efficient Fitness Based Routing Protocol in Wireless Sensor Networks", *ICTACT Journal on Communication Technology*, 5(1), 2014.
- [46] Liu, J. L. and Ravishankar, C. V, "LEACH-GA: Genetic algorithm-based energy-efficient adaptive clustering protocol for wireless sensor networks", *International Journal of Machine Learning and Computing*, 1(1), pp. 79-85, 2011.
- [47] Lee, S. L., Park, J. and Shon, J. G. (2015). "A Two-Layer Cluster Head Selection Based on Distance in Wireless Sensor Networks", In *Computer Science and its Applications*, Springer Berlin Heidelberg, pp. 1003-1007, 2015.
- [48] Gupta, V. and Sharma, S. K, "Cluster Head Selection Using Modified ACO", In *Proceedings of Fourth International Conference on Soft Computing for Problem Solving*, Springer India, pp. 11-20, 2015.
- [49] <https://www.mathworks.in/products/matlab>.

## LIST OF PUBLICATIONS

---

### **Published**

Kansal, S., Bhatia, T., & Goel, S. (2015, February), "Performance analysis of LEACH and its variants", *In Electronics and Communication Systems (ICECS), 2015 2nd International Conference, IEEE*, pp. 630-634.

### **Communicated**

Kansal, S., Bhatia, T., & Goel, S., "Energy Efficient Hierarchical Routing Protocols for WSN: A Review", *International Journal of Communication Networks and Information Security*, vol. 7, no. 1, 2015.

Kansal, S., Bhatia, T., & Goel, S. "An Optimized CH selection using GA and Distance Aware Routing Protocol for WSN" *International Journal of Sensor Networks*, Inderscience Publishers, 2015.

”

## **VIDEO PRESENTATION**

---

This is link to my YouTube video where I have presented brief summary of my thesis topic:

<https://www.youtube.com/watch?v=yuoK9Mx090E>

# PLAGIARISM REPORT

---

---

An optimized CH selection using GA and distance aware routing protocol for WSN

---

## ORIGINALITY REPORT

---

**15%**  
SIMILARITY INDEX

**6%**  
INTERNET SOURCES

**14%**  
PUBLICATIONS

**1%**  
STUDENT PAPERS