

**PERFORMANCE ANALYSIS TO ENHANCE THE GAIN FLATNESS OF
L-BAND EDFA IN 16 CHANNEL WDM SYSTEM WITH MULTIPLE FBGs**

A Thesis Submitted in Fulfillment of the Requirement for the Award of the Degree of

MASTER OF ENGINEERING

In

Electronics and Communication Engineering

Submitted By

Samin Rathore

Roll No: 801661021

Under Supervision of

Dr. Hardeep Singh

(Assistant Professor, ECED)



THAPAR INSTITUTE
OF ENGINEERING & TECHNOLOGY
(Deemed to be University)

ELECTRONICS AND COMMUNICATION ENGINEERING DEPARTMENT

THAPAR INSTITUTE OF ENGINEERING AND TECHNOLOGY

(DEEMED TO BE UNIVERSITY), PATIALA, PUNJAB

JUNE, 2018

DECLARATION

I, Samin Rathore hereby declare that the work presented in this thesis entitled “**Performance Analysis to Enhance the Gain Flatness of L-band EDFA in 16 channel WDM System with Multiple FBGs**” in fulfillment of the requirement for the award of degree of Master of Engineering (ECE) submitted at Electronics and Communications Engineering Department, Thapar Institute of Engineering and Technology (Deemed to be university), Patiala is an authentic record of work carried out under supervision of Dr. Hardeep Singh (Assistant Professor, ECE, Thapar Institute Of Engineering & Technology) from January to June 2018. The matter presented in this report has not been submitted either in part or full to any other university or institute for the award of any other degree.

Date: 6 June 2018

Samir Rathore
(Samir Rathore)
801661021

Hardeep Singh
(Dr. Hardeep Singh)
(Assistant Professor)

Electronics And Communication Engineering Department
Thapar Institute Of Engineering & Technology
(A Deemed To Be University), Patiala, Punjab

Date: 6 June 2018

ACKNOWLEDGEMENT

I wish to express my deep gratitude and sincere thanks to my supervisor, **Dr. Hardeep Singh** Assistant Professor, Electronics and Communication Department (ECED), Thapar Institute of Engineering and Technology, Patiala, for his invaluable guidance, constant encouragement, constructive comments, sympathetic attitude, and immense motivation, which has sustained my efforts at all stages of this work. His valuable advice and suggestions for the corrections, modifications and improvement did enhance my work.

I would like to express my gratitude to **Dr. Alpana Agarwal**, The Head of Electronics and Communication Department (ECED), Thapar Institute of Engineering and Technology, Patiala, for providing me with adequate environment in carrying out the work.

Finally, I want to extend my gratitude to all those persons who directly or indirectly helped me in carrying out this work in right direction.

ABSTRACT

Now a day, there is a requirement of high capacity networks therefore optical fiber comes in the daily use for the communication process like data transmission, video communication purposes. For multimedia purposes optical fiber comes in demand for the communication process over a long distance with the signal security and without any interruption of noise signal. The amplifiers using now a days can tolerate the effects such as linear and non linear effects. In order to fulfill the demands of internet, high capacity systems are required in the system. However, C-band is used by many researchers for researches in the communication and researchers are now in a different way for another wavelength window. Long band comes out to be the solution for the requirements in the problems like high gain and thermal effects. Thus, L-band EDFA is also required to amplify the long band wavelengths. But still the various undesired effects the low performance of the system. High Gain long-band designed EDFA amplifier, effective use of amplified spontaneous noise as a source to enhance gain by the process of reinjection in EDF fiber through the incorporation of FBGs. Various physical parameters of the EDF fiber and pumps are needed to be investigated so that the performance of system could be enhanced. These parameters may also provide the performance of longer distances in the systems. This thesis elaborates the limitation in L-band amplifier along with the problems in C-band EDFA also. The most important differences between the bands such as C-band and L-band EDFA's are demonstrated in this study. Backward power affects the pumping efficiency that is observed by the amplifier spontaneous noise. Also the noise figure can be observed in the amplifier spontaneous by the back pumping effects. On the other hand, signal induced inhomogeneous affected by the ASE power affects in long band amplifiers. In the L-band gain is liable to temperature more than C-band signals. From the C-band actions two fundamentals actions are demonstrated to separate long-band thermal behavior. The effects i.e. thermal effects introduce the fluctuations in the output power and gain tilt also emerged in it. This output power is dependence on the thermal effects at 980 nm and 1480 nm are least or they can be independent in case of C-band. By reinjection of forward and backward ASE performance of gain and noise of L-EDFA achieved by through FBG leads to 1.23 gain flatness. The results show that gain with flattens in L-band EDFAs using FBGs.

TABLE OF CONTENTS

Sr. No	Name of the Chapters	Page No
	<i>Declaration</i>	ii
	<i>Acknowledgement</i>	iii
	<i>Abstract</i>	iv
	<i>Table of Contents</i>	v
	<i>List of Tables</i>	viii
	<i>List of Figures</i>	ix
	<i>List of Abbreviations</i>	x
<i>Chapter 1</i>	Introduction	1-19
<i>1.1</i>	Introduction and Motivation of Optical Fiber Communication.....	1
<i>1.1.1</i>	Basic Block Diagram of OFCs	1
<i>1.1.2</i>	Advantages of Optical Fiber Communication	3
<i>1.1.3</i>	Optical Fiber Communication.....	4
<i>1.2</i>	Multiplexing Techniques Development	4
<i>1.2.1</i>	Introduction of Multiplexing.....	5
<i>1.2.2</i>	Need of Multiplexing	5
<i>1.2.3</i>	Principle of Multiplexing.....	5
<i>1.2.4</i>	Types of Multiplexing Techniques.....	6-9
<i>1.3</i>	Fiber Optic Non-Linear Effect	9
<i>1.4</i>	Introduction to Optical Amplifiers	10

1.4.1 Principle of Optical Amplifiers	10-11
1.4.2 Amplifiers Types	12
1.4.3 Semiconductor Optical Amplifier	12
1.4.4 Erbium Doped Fiber Amplifier	13
1.4.5 Motivation	14
1.4.6 Development of L-band EDFA Amplifier	15-17
1.4.7 Raman Amplifier	17-18
1.5 Different Types of Optical Amplifier	19
<i>Chapter 2 Literature Survey</i>	20-23
<i>Chapter 3 Research Gaps and Objectives</i>	24-26
3.1 Research Gaps	24
3.2 Problem Formulation.....	25
3.3 Research Objectives.....	26
<i>Chapter 4 Proposed Methodology, Results and Discussions</i>	27-43
4.1 Introduction.....	27
4.2 Optisystem Overview.....	28
4.3 Performance Analysis of ASE Reinjectd L band EDFA	28
4.3.1 Simulation Setup	29-37
4.3.2 Results and Discussions	37-43
<i>Chapter 5 Conclusions and Future Scope</i>	44-45
5.1 Conclusions.....	44
5.2 Future Scope.....	45
References.....	46-53

LIST OF TABLES

Sr. No	Table Details	Page No
<i>Table 1.1</i>	<i>Comparison Between Optical Amplifiers.....</i>	<i>19</i>
<i>Table 4.1</i>	<i>Simulation of Different Parameters of L-band EDFA.....</i>	<i>29</i>
<i>Table 4.2</i>	<i>Simulation Parameter of Different Line Codings.....</i>	<i>34</i>

LIST OF FIGURES

Sr. No	Figure Details	Page No
Figure 1.1	Block Diagram of Optical Fiber Communication System.....	2
Figure 1.2	Representation of General Multiplexing.....	6
Figure 1.3	Basic Time Division Multiplexing.....	6
Figure 1.4	Diagram of Wavelength division multiplexing	7
Figure 1.5	Frequency Division Multiplexing.....	8
Figure 1.6	Linear and Non-Linear Effects.....	9
Figure 1.7	Optical Amplification Processes.....	11
Figure 1.8	Semiconductor Optical Amplifier.....	12
Figure 1.9	Three Level Energy Diagram of Er ³⁺ Ions	13
Figure 1.10	Erbium Fiber Gain Coefficient Computed Diagram.....	15
Figure 1.11	Block Diagram of Raman Amplifier.....	17
Figure 1.12	Quantum Mechanical Process of Raman Scattering.....	18
Figure 4.1	Research Methodology of Work.....	27
Figure 4.2	Setup Simulation of Proposed L-band EDFA.....	30
Figure 4.3	Modulation Scheme of NRZ.....	31
Figure 4.4	RZ Modulation Scheme.....	32
Figure 4.5	Proposed L-band EDFA System for NRZ and RZ.....	33
Figure 4.6	Representation of 16 Channel L-band EDFA.....	36
Figure 4.7	Gain and Noise Figure Spectrum of EDFA According to Input.....	38
Figure 4.8	Graph of Forward and Backward ASE Results.....	38
Figure 4.9	Results of Gain and Noise Figure After the Forward and Backward ASE.....	39
Figure 4.10	Length of Erbium Doped Fiber Versus Output Power.....	39

<i>Figure 4.11</i>	<i>Core Radius Versus Output Power After ASE Reinjection</i>	<i>40</i>
<i>Figure 4.12</i>	<i>Length of EDFA Versus Output Without ASE Reinjection</i>	<i>40</i>
<i>Figure 4.13</i>	<i>Core Radius Versus Output Power Without ASE reinjection</i>	<i>41</i>
<i>Figure 4.14</i>	<i>Distance Versus BER</i>	<i>41</i>
<i>Figure 4.15</i>	<i>Distance Versus Q Factor</i>	<i>42</i>
<i>Figure 4.16</i>	<i>Graph Plotted Between the Received Power and the SNR</i>	<i>42</i>
<i>Figure 4.17</i>	<i>Graph Depicts the Gain With and Without Flatness</i>	<i>43</i>

LIST OF ABBREVIATIONS

<i>OFC</i>	<i>Optical Fiber Communication</i>
<i>O/E</i>	<i>Optical to Electrical</i>
<i>E/O</i>	<i>Electrical to Optical</i>
<i>QoS</i>	<i>Quality of Service</i>
<i>EMI</i>	<i>Electromagnetic Interference</i>
<i>TDM</i>	<i>Time Division Multiplexing</i>
<i>WDM</i>	<i>Wavelength Division Multiplexing</i>
<i>FDM</i>	<i>Frequency Division Multiplexing</i>
<i>SOA</i>	<i>Semiconductor Optical Amplifier</i>
<i>EDFA</i>	<i>Erbium Doped Fiber Amplifier</i>
<i>ASE</i>	<i>Amplifier Spontaneous Emission</i>
<i>PCE</i>	<i>Pump Conversion Efficiency</i>
<i>OOK</i>	<i>On Off Key</i>
<i>BER</i>	<i>Bit Error Rate</i>
<i>NF</i>	<i>Noise Figure</i>
<i>HOA</i>	<i>Hybrid Optical Amplifier</i>
<i>FBG</i>	<i>Fiber Bragg Grating</i>
<i>NRZ</i>	<i>Non Return to Zero</i>
<i>RZ</i>	<i>Return to Zero</i>

CHAPTER 1

INTRODUCTION

1.1 INTRODUCTION AND MOTIVATION OF OPTICAL FIBER COMMUNICATION

Information uprising implies that networks based on internet require high bandwidth for information exchange between multiple points. In today generation, fiber optics is the communication medium which provides suitable wide-bandwidth. Fiber optic offers degradation of low signal in the transmission lines[1]. There is an increase in demands of the optical fiber based communication system because it offered high capacity transmission medium and therefore having their use in multiple points. Since 1980s fiber optic based systems are one of the quickly arising industries. Networking through optical fiber is the most significant solution to comfort the requirements for high bandwidth. The amplitude degradation of fiber optical system in the beginning was very leading and therefore progressively worse loss of signal of up to 1000 dB/km[2]. Using Coming Glass Works researcher realizes that attenuation breakthrough at 20dB/km during 1970. And through this optical fiber become very reliable. With the increasing scope of fiber optic system the amplitude degrades to 0.2dB/km and leads to high transmission.

1.1.1 Basic Block Diagram of Optical Fiber Communication System (OFCs)

Figure 1.1 depicts the optical fiber strands transmission system. Signal power of the pulses get deteriorate as link length prolongs in the communication system on fiber optic. Fiber optic length can reduced the attenuation loss and other losses by the use of repeater known as optoelectronic repeater [3]. Optical signal is the signal that is first converted into electrical signal and signal is amplified then. Amplified signal is regenerated by the sender/transmitter. However, this process becomes more complex to a certain extent and further for the multiplexing systems like frequency division multiplexing or wavelength division multiplexed systems. With the regeneration process there is an occurrence of losses of signal and complexity so to avoid the complexity and losses, to convert the optical signal into electrical signal i.e. O/E conversion there is no need. The use of Optical signal amplifiers plays an important role in gain. As optical signal amplifiers

provides linear mode applications like repeaters, pre-optical amplifiers, op-amp. The non-linear modes also exist in the aforementioned amplifiers like routing switches operation, switches, optical gates etc.

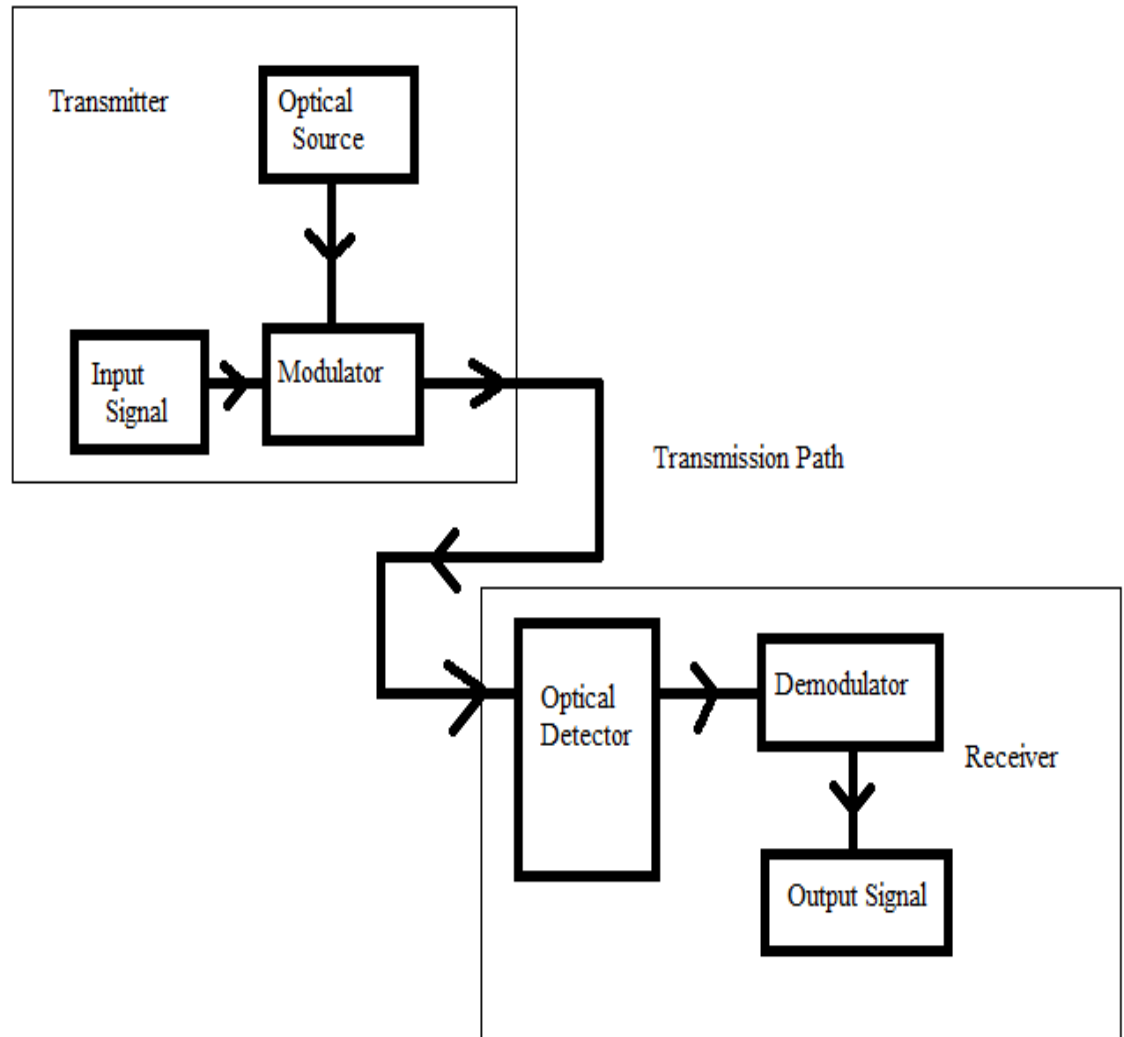

Figure 1.1 Block of Optical Fiber Communication System[10]

For the amplification in optical fiber system amplifiers are generally used to entire the amplification of multiplexing system like wavelength division multiplexing system. This scheme is known as optical in-line amplification scheme [4]. Bit rate transparent and strengthening of signals diverse all together are the most important property. Moreover this property used in optical fiber system and can be used in different applications. Pre configuration and post configuration are the two placements used in

optical fiber communication system for amplifiers. When the amplifier is placed in the transmission link it acts as power booster. Optical amplifier is placed at the former case in which the transmission link is also prior to the fiber optic so that they can be act as power booster. And in the post configuration, to act as booster of incident power the optic amplifier is adjusted after the fiber optic. The insertion of optical amplifier in the communication system increases the length between these links.

1.1.2 Advantages of Optical Fiber Communication

- Optical fiber cables are cheaper in the cost so these cables can be used at overall systems and provide the excellent solution compared to co-axial cables and wires.
- Optical fibers are very easy and as simple and can be installing in any network for sharing the information.
- Optical fiber cables are less impact able of environment conditions.
- A large number of wavelengths can be supported by the optical fiber because it provides wide bandwidth with the high speed bit rate transmission.
- In optical fiber communication systems, there is less degradation of amplitude signal.
- A major advantage of optical fiber in the communication system is that there is no need or less use of repeaters in the system.
- There is less broadening of signals and prolonged link length networks are achievable.
- A major advantage in fiber optic based communication systems, Bidirectional transmission can be done.
- Optical fiber is less immune to the noise and there is no crosstalk occurs.
- Optical fiber communication provides signal security as compared to other communication purposes.
- In optical fiber communication the bidirectional transmission can be realized.
- In optical fiber communication system there is no occurrence of EMI interference.
- Optical fiber system supports full duplex communication system with high quality of service (QoS).
- Optical cable provides long distance transmission with higher bit rate.

- A limiting issue in electrical medium system is that there was an issue of electromagnetic interference (EMI).

1.1.3 Optical Fiber Communication

1. Transmitter: Transmitter is the foremost section of the system transmits the input signal from one place to another. Transmitter consists of various components like modulation, data generator and light source. Transmitter transmits the information signal to the another source.
2. Channel: It is a medium part of the communication system that exchanges the information between the one point to the many number of points. Optic fiber mechanism, the medium is made up of fine fibers or glass or a metal tube (waveguide) that engage an important part in transmitting the short burst (pulse) or optical signal from the sending end to the receiving end. Optical fiber provides much security of information signal as compared to the electrical signal applications like military applications. Principle of optical fiber is the total internal reflection. With the help of this principle the size of core and clad is adjusted too small. With the phenomenon of total internal reflection, the leakage of information signal is prevented. Hence total internal reflection plays an important role in optical glass fiber system.
3. Receivers: Receiver receives the information signal in the form of electrical signal. To convert the electrical signal into light signal various components are used like photo detectors. These components are automatically inserted inside the receiver. Photo detector generates the light photons which are then converted and pass through the low pass filter to remove the unwanted noise. At the end of the receiver to achieve the signal in the suitable form or in the desired signal photo detectors are needed or sometimes the photo detectors are automatically comprised inside the receiver. The various general detectors can be used and are further divided into two types [5] namely P-i-N and avalanche photo detector. These general detectors are used at the end of receiver.

1.2 MULTIPLEXING TECHNIQUES DEVELOPMENT

1.2.1 Introduction of Multiplexing

The originating scope of the communication or exchanging message in the early eighteenth century, increase in scope of exchanging information was there. Signal can be sent over a single channel and passed it to the multiple users. It is a communication medium where analog and digital signals are combined together and they are transferred over a single channel. Multiplexing is the most popular technique used in the communication process. Use of multiplexing technique reduces the cost of the system. Therefore cost of the information among the users gets increased to the number of transmission lines. So as the increased number of transmission lines creates the problem in the systems. To increase the capacity of the system researcher started looking forward. As a result they overcome with the problem with the multiplexing technique. With this technique single signal is sent over the same channel at the same time known as multiplexing [6].

1.2.2 Need of Multiplexing

In the multiplexing technique the system capacity gets increased but there is a loss of bandwidth, bandwidth is not fully utilized. The overall capacity of the transmission mediums are of great size. The available bandwidth was not used properly. So most of bandwidth get wasted and there is no any electronic system which we can make use of the bandwidth in the transmission system. Some approaches can be done so the there will be proper utilization of bandwidth in the network.

If the bandwidth is greater than the transmission communication in the optical fiber cable then the unwanted bandwidth can be dispersed. The proper utilization the bandwidth in the optical fiber cable is known as multiplexing. This multiplexing technique makes use of bandwidth and the extra bandwidth is dispersed. The number of channels is packed by the widespread technique and with the use of fiber and cables distance transmission is possible with the multiplexing technique [7].

1.2.3 Principle of Multiplexing

Figure 1.2 shows the block diagram and operation of multiplexing. Multiplexer with n inputs is coupled with the de- multiplexer with a single link from end to end .The data is

sent over a single channel. The data with large bandwidth is broadcast over the medium. On the other side, de-mux according to the frequency the channels are transmitted to their ports. As a result, multiplexing is a suitable technique in which channels are accommodated at the same instant of time.

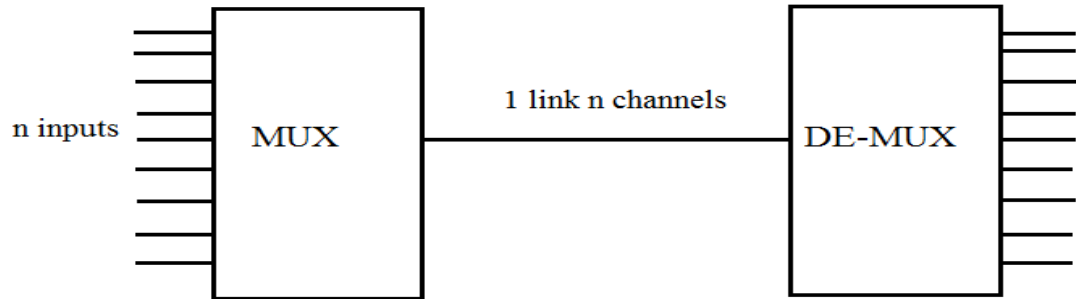

Figure 1.2 Representation of General Multiplexing[7]

1.2.4 Types of Multiplexing Techniques

There are different multiplexing methods which are used in this section. Different multiplexing techniques are listed below:

(a) Time Division Multiplexing (TDM): In this type of multiplexing, independent signal is transmitted with the given time slots with the help of synchronized switches. As a result, only one switch is activated with the given interval of time. But time division is not very effective. Basic TDM is shown below in the Figure 1.3.

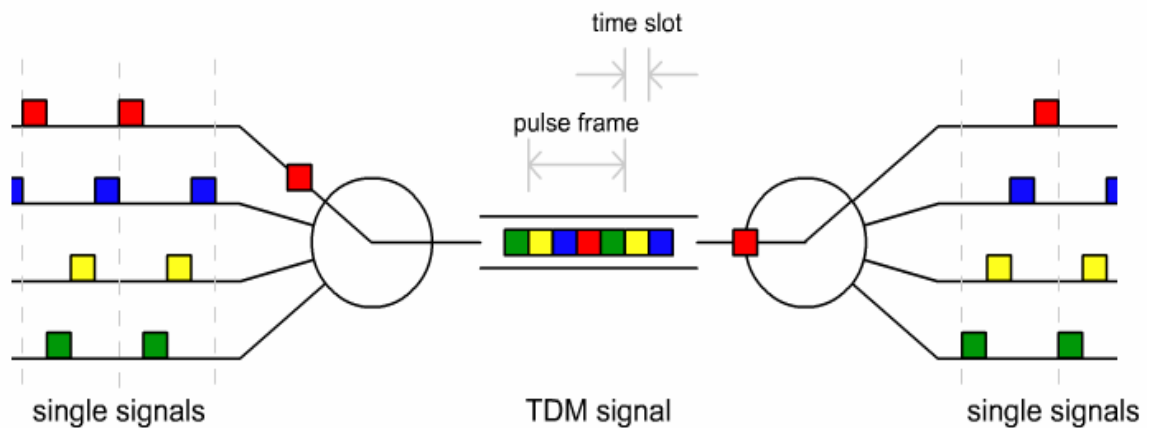

Figure 1.3 Basic Time Division Multiplexing [7]

Time division multiplexing technique does not own as much benefits so this multiplexing technique is not used. Hence we require multiple channels to be transmitted in the channel, then if we require multiple number of channels, then different methods should be used [6].

(b) Wavelength Division Multiplexing (WDM): In wavelength division multiplexing technique large number of wavelength is transmitted through one medium. For different channels there should be different wavelengths. As compared to the time division multiplexing technique, there is different time slot allotted to the different channel and in the wavelength division multiplexing technique different wavelength is spaced for different channels. In the time division multiplexing, communication takes place in parallel unit. Therefore, large bandwidth and timing is saved in this method.

The wavelength division multiplexing technique uses different wavelength signal that is applied to the multiplexer at the same time and passed through the single fiber. In this way the signal integrity is not get distributed. This technique is very useful in the communication for multiplexing hence this is the bottleneck for the communication [6]. WDM techniques are very famous and used for the optical fiber systems.

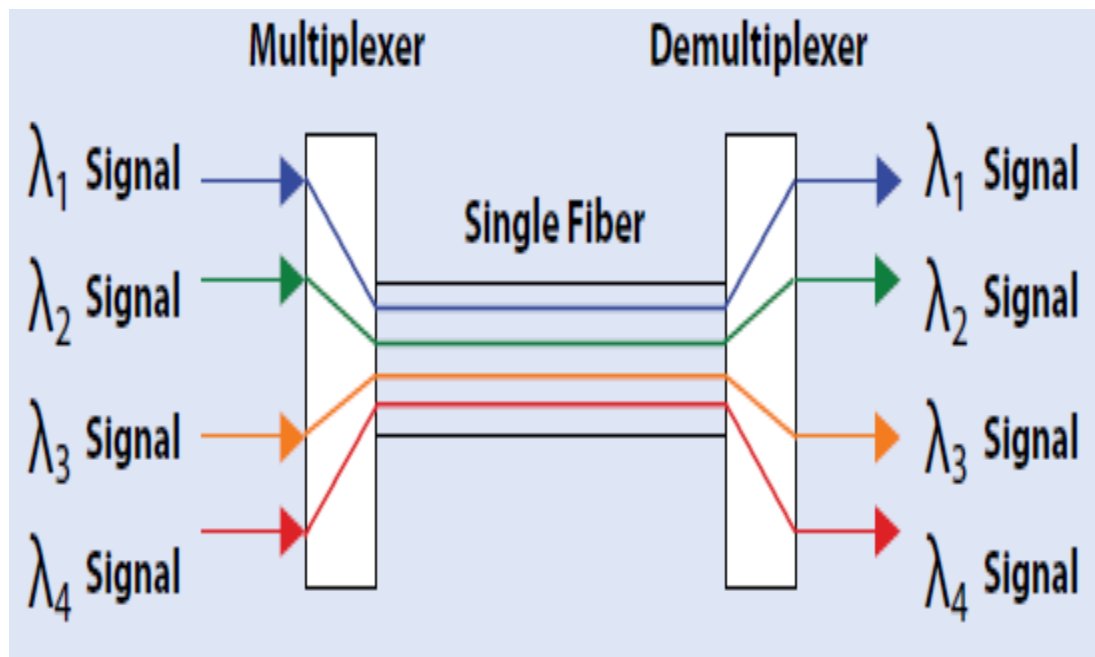

Figure 1.4 Diagram of Wavelength Division Multiplexing[8]

(c) Frequency Division Multiplexing (FDM): FDM technique is the technique in which frequency is divided in the multiplexing process. This technique having the capacity of bandwidth of medium is more than the capacity of bandwidth of signal. So there is no requiring of more bandwidth of the transmission of the signal. The FDM increase the capacity of the system and it also increases the flexibility. The RF (radio frequency) increases the flexibility with the huge bandwidth potential. Frequency division multiplexing provides large capacity and different frequencies of the channels are located nearby to each other.

In frequency division multiplexing, the information can be moved at a time through the medium. If there is a free spectrum guards bands are present so there will be no intervention in the information signal. Frequency division multiplexing supports radio wave communication systems and time division multiplexing is very popular. There is sequential delay in the multiplexing and is the common improvement. In time division multiplexing there is wastage of time because there is a delay in transmitted signal.

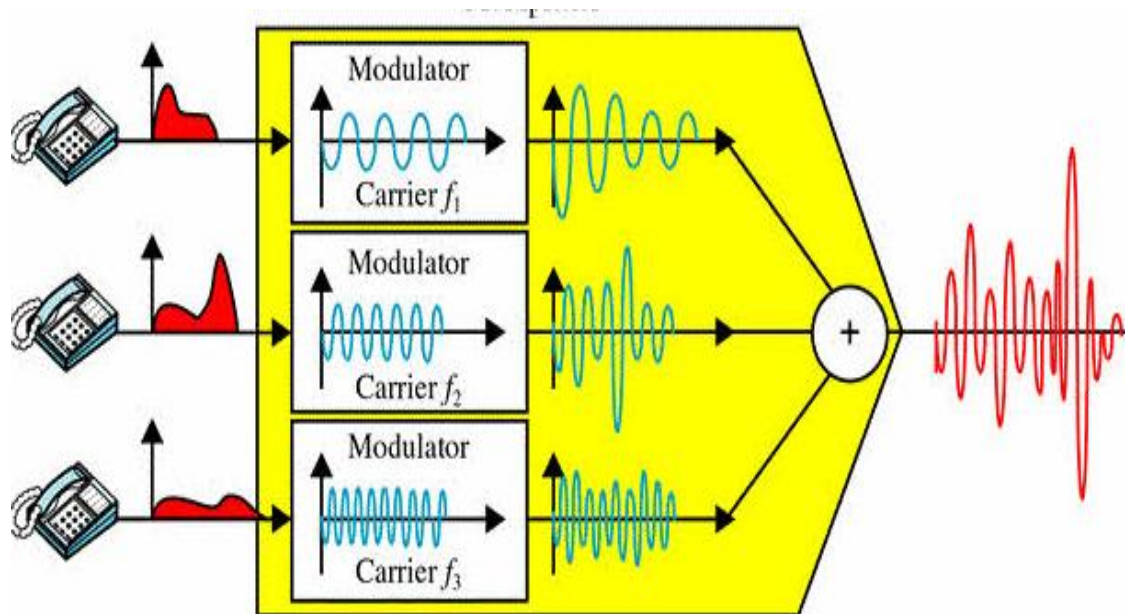

Figure 1.5 Frequency Division Multiplexing [8]

To increase the capacity of the system single mode fiber is used. In single fiber optic more channels can be accommodated in the fiber strand which can be used in different

multiplexing systems like WDM or Dense WDM (DWDM). Problems like degradation of the signal and broadening of pulse overcome with the use of multiplexing technique i.e. DWDM technique. The dispersion namely polarization mode dispersion and pulse broadening (dispersion) are of two types. This dispersion is the linear impairments. The incident power and refractive index variation are comprised of Cross-Gain and phase Modulation i.e. XGM, XPM and also comprises of mixing and modulation technique i.e. FWM (Four-Wave Mixing) and SPM (Self-Phase Modulation).

1.3 FIBER OPTIC NON-LINEAR EFFECTS

Optical fiber is needed as an optical domain to exchange the information between the two pointsources. In some case multiple channels like WDM systems, they have their individual power level. If the channel has their incident power high then there channel accumulative power is also high. Refractive index is affected by the high power when it is sent to the fiber. Therefore phase of the signal varies when speed of the each WDM signal also varies. So these effects are non linear in the optical fiber. This is a performance degrading issue and moreover, it also bound the total bit rate, connection distance end to end and channels spacing selection freedom in the system [9]. Figure 1.6 depicts the variety of special effects in the optical fiber cable. Linear effects such as attenuation, dispersion as well as nonlinear effects are comprised of these.

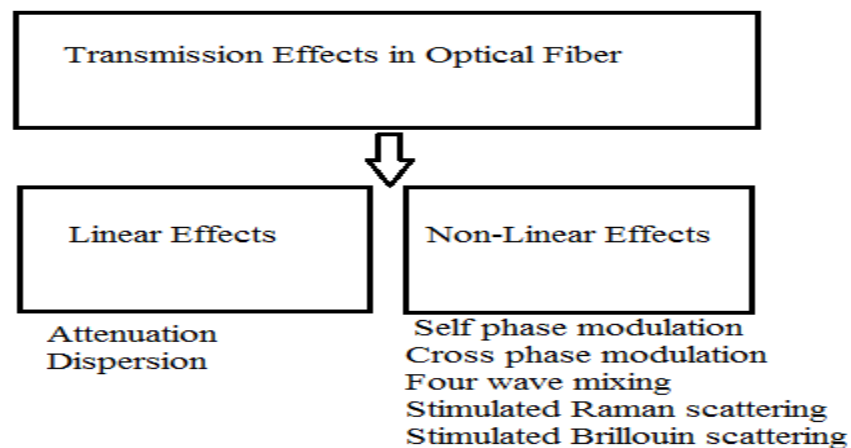

Figure 1.6 Linear and Non-Linear Effects [9]

1.4 INTRODUCTION OF OPTICAL AMPLIFIERS

The signal degradations in the fiber optic such as power loss (attenuation) because of a range of effects like bending take place when communication of signal accomplished. Signal with high quality is difficult to access the system at the reception side. There is a need to realize the long length communication link. Laser intensity is required in the communication link to modulate the data. Regenerators are used in the system to overcome the attenuation effects in the communication system. In the optical fiber system there is need to convert the optic into electrical signal, then electrical signal into optical signal. Conversion of signal makes the system complex. Optical amplifiers are needed to boost the signal without any conversion of signal. This advantage of boosting the signal increases the scope in fiber link length transmission. So this makes the optical amplifiers more flexible and reliable. Change in the characteristics of transmitter and receiver transform the code of an existing amplified link. On the other hand, a repeater is used in the system. Sometimes it becomes difficult to use them in inconvenient environment [10].

1.4.1 Principle of Optical Amplifier

Principle of amplification is very simple in optical. Existence of atoms and discrete state of energy performs the principle of amplification in optical amplification process. The different energy states and has their own principle. There are discrete energy states. In the process of absorption high energy is achieved and there is also a process of losing energy for coming back to ground state. There is a difference in ground state and emission state. Both states of emission and absorption are equal to the difference in ground state and excited state as presented in Figure 1.7 (a). When the light or photon strikes the excitation state takes place and energy get stored by the atom as given in Figure 1.7 (a). Atom does not remain stable when it reaches at higher state and after generating photon it generally comes to the ground state as shown in Figure 1.7 (b). This emission is known as spontaneous emission in the energy states [4]. This phenomenon is used in the optical fiber amplification. Spontaneous method is accomplished at the time when incident photon with energy $E = hc/\lambda$ [11] this energy act together with electron in high energy or excited energy state. Spontaneous method provides meta stable state potential by losing some of energy from the total energy. Meta stable state is near to the

excited state and just below to this level. After losing high amount of energy the atoms return to ground state but a photon is generated when an atom reaches to the ground state as presented in Figure 1.1 (c). For the amplification process there will be high energy states in an atom. If there will be high energy states in an atom as compared to low energy state then there will be population inversion. The $N_1 < N_2$, where N_1 , N_2 are the densities i.e. population densities of two states namely the lower state and upper state.

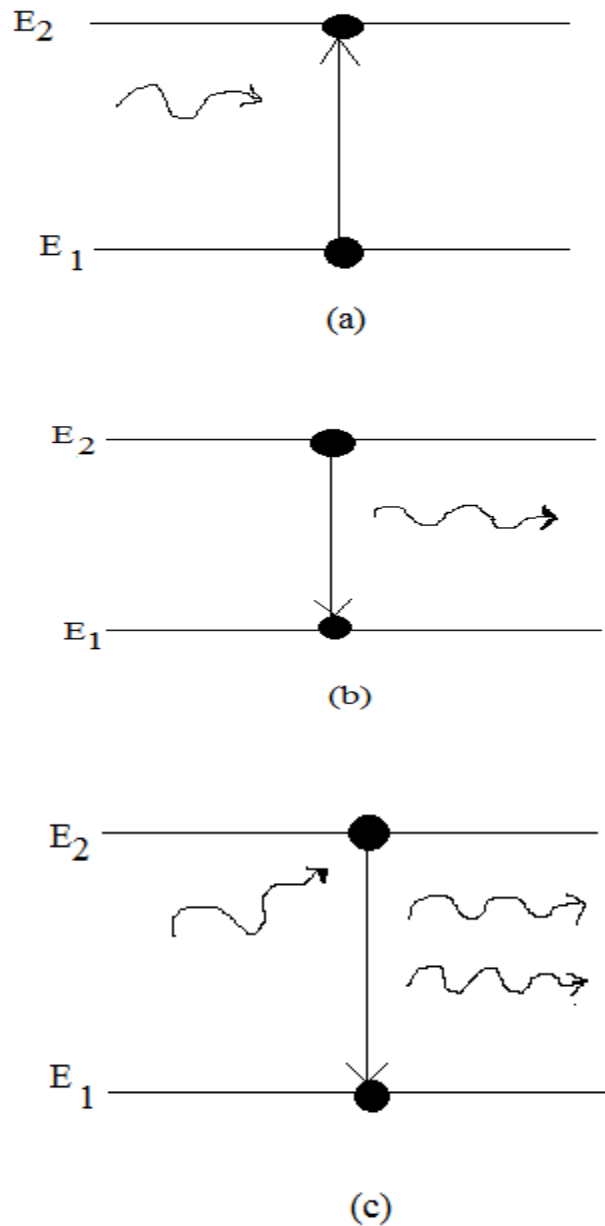

Figure 1.7 Optical Amplification Processes (a) Absorption Process (b) Spontaneous Emission and (c) Stimulated Emission Process [12]

1.4.2 Amplifier types

There are different types of amplifiers in optical -:

- ❖ Semiconductor Optical Amplifier
- ❖ Erbium Doped Fiber Amplifier
- ❖ Raman Amplifier

1.4.3 Semiconductor Optical Amplifier

Semiconductor optical amplifiers (SOA) are the amplifiers used for amplification. At the both ends of semiconductor optical amplifiers (SOA) mirrors containing optical fiber is connected. The anti reflection coatings are used as end mirror in this amplifiers. To diminish the reflectivity of particular wavelength the dielectric coating is done at both the sides of fiber optic. Wide range of wavelength are boosted by the semiconductor optical amplifier that is applied to one end and emerged to another end. In SOA amplifiers population inversion different from other amplifiers. There is a material i.e. semiconductor material is used. As due to the semiconductor material the population inversion is of electrons and holes irrespective of the ions [13]. Semiconductor optical amplifier diagram is given below Figure 1.8 [14].

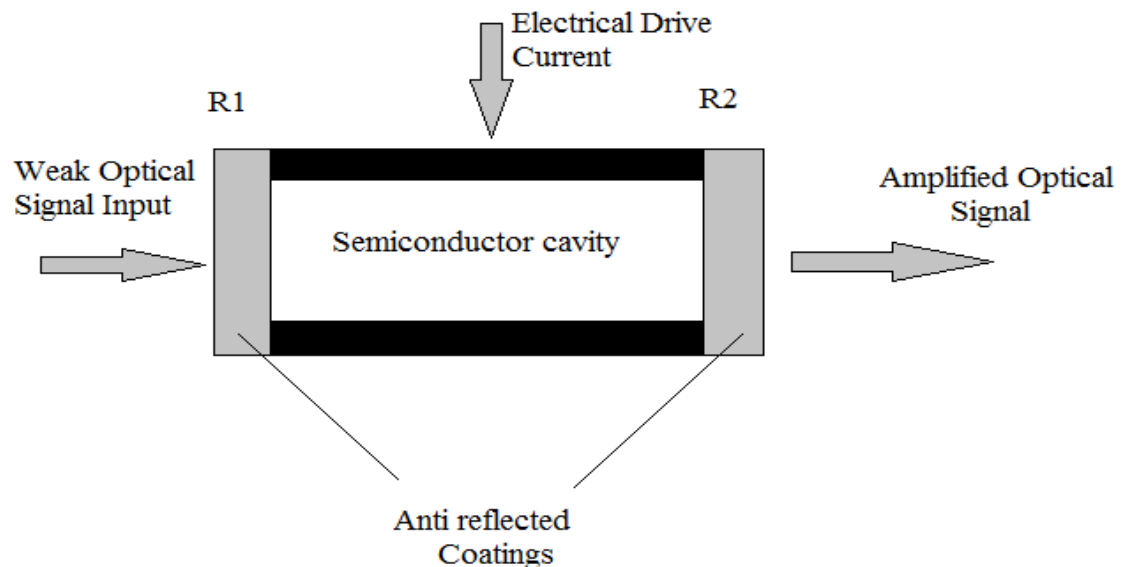

Figure 1.8 Semiconductor Optical Amplifier (SOA) [14]

1.4.4 Erbium Doped Fiber Amplifier

Different earth elements used in the various applications such as erbium, ytterbium and thallium. These elements can be doped into optical amplifiers and fiber amplifier function is created and these amplifiers function can diverse the wavelengths from 0.5 μm to 3.5 μm . Erbium doped amplifier is reliant on the silicon material erbium ions is doped on it. Erbium doped ions offers maximum gain medium. To boost the signal in erbium doped fiber amplifier two pump wavelengths are required for work. There are basically two bands which EDFA supports such as C and L band. On C band the pump wavelengths of 980 nm and 1480 nm has been reported. Energy states and erbium doped amplifier represented in Figure 1.9

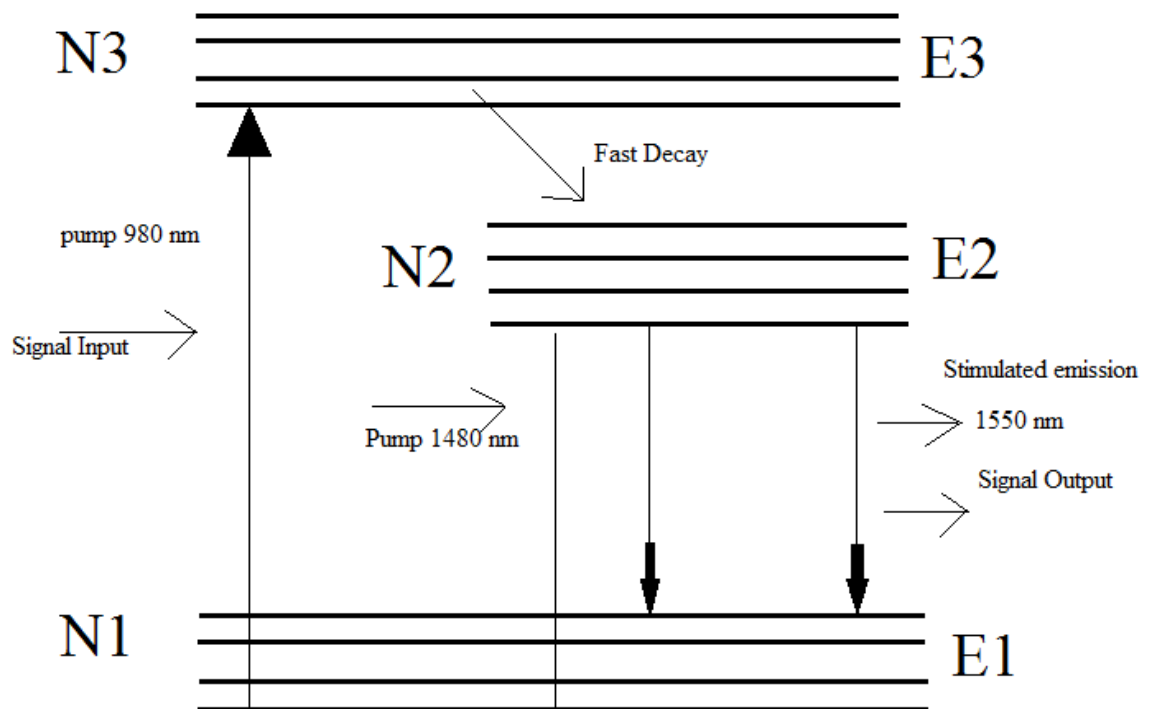

Figure 1.9 Three Level Energy Diagram of Er³⁺ Ions [15]

Due to the increasing demands of band, in WDM systems L-band is incorporated the systems. But the problem occurred is that we cannot get the maximum gain. L-band experiences the uneven gain. In C-band we get the maximum gain as compared to L-band we face the problem of lower gain.

1.4.5 Motivation

Dense wavelength division multiplexing was introduced in 1994. Current optical fiber communications systems use dense multiplexing called wavelength division multiplexing. This multiplexing technique was introduced with the erbium doped fibers. Bandwidth of optical fiber is incorporated with the C-band amplifiers which covered 35 nm using gain flattening filters. Now a day's internet services double the demand of capacity of system. As the demands of internet services are increasing the expected data capacity OC-768 is required. The systems need large bandwidth so to provide the bandwidth to the systems there are different ways to augment the capacity of systems. The capacity of systems can be increased by increasing the data rate speed, bandwidth of optical fiber should be widened and densely spaced of packed channels in the optical fiber.

System suffered from different broadening effects in order to realize the high speed per channel. The different broadening effects are dispersion and polarization mode dispersion. Size of each pulse maintain in the system so transmitter, dispersion compensation scheme is needed in the system. Channel spacing is reduced by pack of more channels in the optical fiber. To increase the performance of the system four waves mixing is emerged in the system hence we can deteriorate the system performance. In C-band erbium doped amplifiers this bandwidth is constrained by means of restricted bandwidth accessible to the doped fiber amplifiers.

Use of L-band amplifiers in the system offers many applications in the communication system. L-band amplifiers offer the boosting of communication bandwidth. It also distinguished full-grown and this technology can be employed to facilitate L-band.

Applications of L-band EDFA amplifier:

- ✓ Capacity enhancement to avail wide bandwidth.
- ✓ Bidirectional C band and L band networks.
- ✓ Less prone to FWM.
- ✓ Systems intended for service specific data transmission.
- ✓ Wide wavelength array amplification

1.4.6 Development of L-band EDFA Amplifier

This part describes the topic of the development and advances in L-band erbium doped fiber amplifier. Most of the works that incorporate EDFA in the system falls in C-band (1528 nm – 1562 nm) as depicted in Figure 1.10.

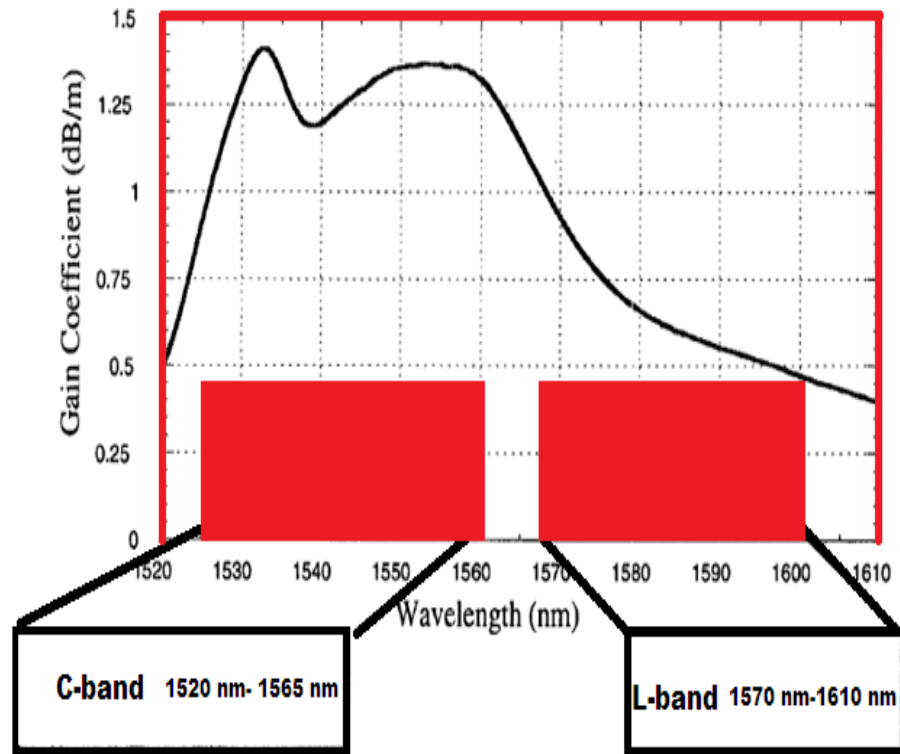

Figure 1.10 Shows the Erbium Fiber Gain Coefficient Computed for 63% Average Inversion Level

The optical frequency window coincides with erbium ions energy level such as $^4I_{13/2}$ - $^4I_{15/2}$. On the other side, there is a long band from 1570 nm to 1610 nm with the tail of energy level such as $^4I_{13/2}$ - $^4I_{15/2}$ [19] [20]. Due to the tail of gain in the L-band, emission coefficient in this band is lower approximately three times than C-band. To operate at the low insertion in EDFA band are forced to do it and then the suppression of gain ripples is obtained [21].

Gain flattening filters are the filters to flatten the gain. There are many choices for implementations to flatten the gain. Gain flattening filters is considerable in C-band erbium doped amplifiers to persist an exciting issue. Two factors are needed in this

limitations are L-band require erbium fiber typically five times longer than C-band EDFA. In L-band EDF length numerous limitations are prolonged. Issues occurs due the longer length of coils are introduced for the manufacturing of amplifiers in the bulk. Moreover, due to the optical fiber losses the pump conversion efficiency (PCE) is low. Pump conversion efficiency is the power of the pump. This power is required to obtain output power signal. Furthermore, pumping power get absorbed till the signal reaches to the end of the erbium doped fiber. Due to this phenomenon, signals bump into absorption loss in the optic un-pumped fiber region. Pump conversion efficiency (PCE) also get decreases due to this technique. Backward power amplifier spontaneous emission (ASE) there will be lesser emission and absorption cross section. To obtain the gain pump conversion efficiency (PCE) is deteriorate the pump photons, the pump photons boost the backward ASE power as an alternative of being used to boost signal power.

With the backward amplified emission spontaneous noise is minimized at the front-end of the amplifier and this amplified emission consequently enhances the noise. In L –band amplifiers there is no good performance of pump conversion efficiency and the noise figure performance as compared to the C-band amplifiers. Growth of erbium doped fiber technology sorted the limitations by doping more ions er^{3+} . Nowadays, EDF fiber contains the 1900 ppm concentration of erbium ions. So with the ppm concentration there is reduction in attenuation due to the use of longer EDF fibers. Pump amplifiers are generally used in the C-band context of EDFA. The wavelength of pump is 980 nm and 1480 nm. Above mentioned wavelength for pumping is used for the amplification purposes. For the front-end wavelength pumping 980nm and 1480 nm of wavelength are used and then further for the pump conversion efficiency. In the starting of the system to avoid noise the 980 nm pumps are applied to the systems. To provide high output power i.e. 1480 the optimal wavelength for pump is applied in the final stage. For long band wavelengths this fundamental property is applied. For the wavelengths of long band there are different options for pumping. L-band is used for pumping options for new wavelength. In past times, the pump wavelength was set up at 30 nm either the direction about 980 nm is away from the absorption peak. Conversion efficiency of pumping is 980 nm to enhance the power. The major disadvantage is the noise figure is so high in the

system. And the other disadvantage in L-band amplifiers is that these amplifiers are used to pump at very high efficiency about greater than 1550nm. ASE power is utilized within the C-band as the pump power. The noise occur in the pumping is the amplified spontaneous emission noise. The ASE power can be achieved by converting the reuse of pump power. This method can be achieved in the system to minimize pump power requirements in the system and also to get lower noise figure.

1.4.7 Raman Amplifier

Single mode fiber is the most effective as a medium of gain. These fibers are incorporated by itself in the gain medium. With high pump power the boosting of signal phenomena termed as Raman amplifier. There are more than one Raman Amplifiers as well as discrete or lumped like EDFA's. Shorter wavelength is used in the fiber to have amplification. Discrete amplifier is the amplifier that specifically uses the short wavelength of fiber. Distributed configuration systems that use fiber optic system and there are two types of pumping that are used in the configuration systems. The co-pumping process is used in the system. Co-pump is defined as the pump is used in the direction of signal or the pump is used near the transmitter. If the opposite direction of the pumping is used in the propagation of signal then it is called as the counter pumping. Though the overall gain dependent on the pump power and wavelength.

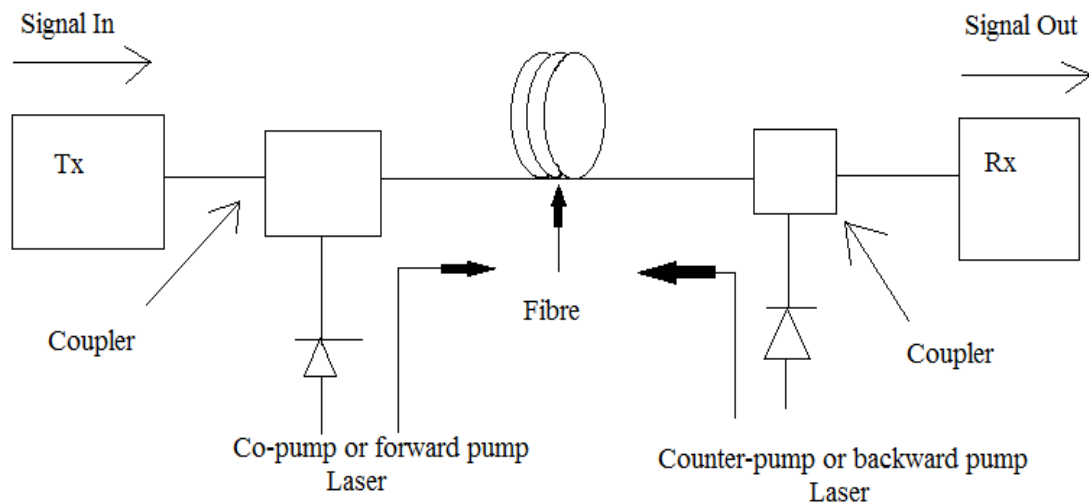

Figure 1.11 Basic Block Diagram of Raman Amplifier

Raman amplifiers amplify the wavelengths ranges from 1280 to 1650 nm. The amplification is based on Raman scattering which is a nonlinear effect in which a signal is captivated as well as at once emitted back photons, thus amplifying the signal. Low frequency is generated on the optical fiber when the light is incident on it. This is shown in Figure 1.11 Material absorbed the pump photon (ν_p) and at the non-resonant state the molecules get energized to the exciting state called as virtual state. After the molecules get decay quickly to lower energy state, photon of different energy is released by it (ν_s). Raman gain curve is decided by the host material of molecular and it also decides the frequency shift [21].

Raman amplifier has different advantages and further can be used in different applications. Though Raman amplifier is most attractive and also the cost effective. Raman scattering provides the gain at longer wavelength distance and occur in any type of the fiber. This scattering is very reliant to the pumping technique. Gain of Raman amplifiers provides the gain flattens and the amplification process is very fast. Virtual state is the short lived state [21].

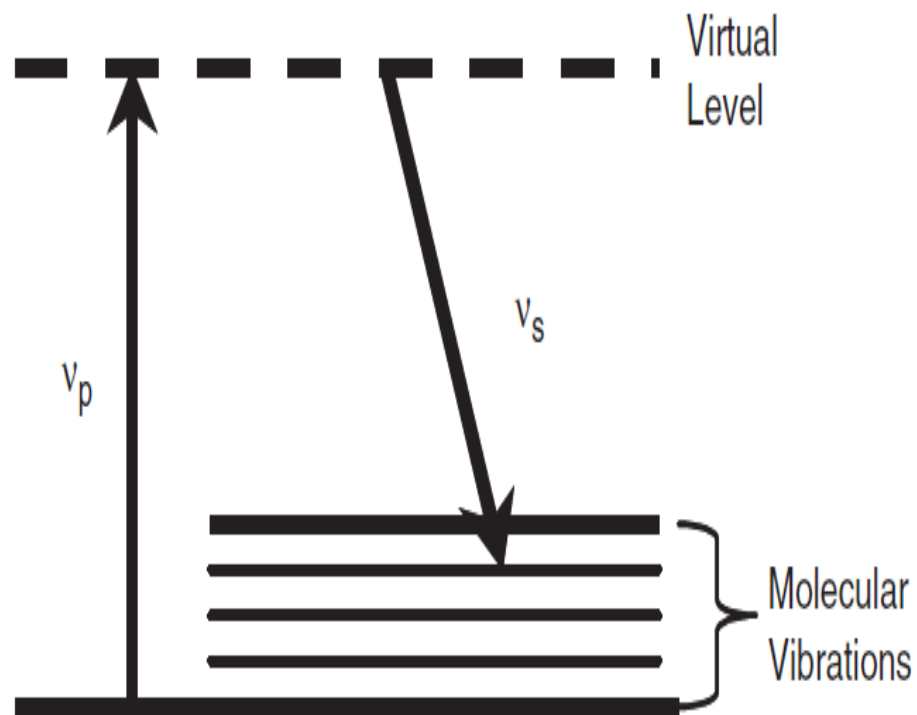

Figure 1.12 Quantum Mechanical Process of Raman Scattering [21]

1.5 DIFFERENT TYPES OF OPTICAL AMPLIFIERS

Table 1.1: Shows the Comparison Between Optical Amplifiers

Specification	Erbium Doped Fiber Amplifier (EDFA)	RAMAN Amplifier	Semiconductor Optical Amplifier (SOA)	Hybrid Optical Amplifier (HOA)
Supported Wavelength	1525 nm-1565nm	Any, depends on power of pump and wavelength	limited to <50nm BW	Any with high Gain
Directions Types	Monodirection and bidirection	Monodirection and bidirection	Monodirection and bidirection	Monodirection and bidirection
Bandwidth Gain	10nm-40nm	20nm-50nm	20nm-50nm	>80nm with large gain flatness
Power of Optical Pump	20mw-50mw	100mw-500mw	NA	Residual pump can be from 100mw-600mw
Sensitivity of Polarization	0 db	0 db	>few mw	Can Vary
Wavelength of Optical Pump	980nm, 1400nm and -1500nm	Stoke shift below the signal	NA	Residual wavelength of pump from 1400nm-1500nm
Noise	Low	Very low	Low	Low

CHAPTER 2

LITERATURE SURVEY

In 2017, FıratErtuçDurak *et al.* [27] demonstrate enhancement of gain figure and the noise figure reduction in the amplifier that is L-band erbium-doped fiber amplifier (L-EDFA). Effects of reinjection i.e. amplified spontaneous emission (ASE) reinjection were incorporated in this work. Different configurations was used in the reinjection i.e. 1533 nm of fiber brag gratings (FBG's).Single-stage dual-directional pumped conventional long band erbium doped fiber amplifier is compared with the outcomes that are presented.This presented the reinsertion of long band EDFA when forward as well as backward ASE noise is double/single 1533 nm FBGs. Thus the resulted performance of the system enhanced in terms of gain and noise. It was also seen that configurations of the FBGs play vital role in deciding the gain. By reinjection of ASE (forward and backward) gain performance was achieved and the noise figure was achieved by it. FBG1 and FBG2 are the gratings that leads to about 4.5 dB enhance the gain at 1585 nm and -30 dBm launched power in the system.

In 1997, Masuda *et al.* [28] presented a result that a large bandwidth iscovered by the optical amplifier that achieves the amplification. This amplification is achieved in the wavelengths array of 65 nm. The range of wavelengths such as 1549nm to 1614 nm is covered in the system Counter pumping process is used in this work, in the fiber base Raman amplifiers with gain equalizers. In this work the use of the diverse arrangements of erbium amplifiers demonstrated the potential to provide ultimate solution to the high capacity WDM system. The bandwidth of 49 nm covers the capacity of WDM system. High power in the amplifiers requirements are also checked in this work by the author. These results are demonstrated by the author like requirements of the high power, wavelength range etc. Gain can be achieved by the launching of greater power level. This work proposed the use of amplifiers like EDFA with Raman amplifier, better gain can be achieved and also the SNR.

In 1999, Kawai *et al.* [29] presented demonstrated a work using wavelength division multiplexing and WDM channels to achieve a 2.5 Gbps system. Total number of WDM channels was fourteen. Due to the amplification of high bandwidth, hybrid optical amplifier has been demonstrated in the system so that system can easily accomplished the link length of 900 km. Hybrid amplifiers offers the suitable outcomes as compared to the multiple erbium doped fiber amplifiers. The author presented the results using of hybrid amplifiers in the system.

In 2001, Zhu *et al.* [30] presented the use of WDM systems and the high speed capacity is demonstrated in the system. In this work the author use the 77 channels having their bit rate speed of 42.7 Gbps. Hybrid configurations of erbium doped fiber amplifier and Raman optical fiber amplifier, are used for the achievement of 1200 km and was successfully accomplished. Author setups the hybrid amplifier at a distance of 100km. Bit error rate in the system seen to be minimum. Author considered the spacing of frequency about 100 GHz.

In 2002, Masuda *et al.* [31] presented a novel configuration of amplifier that provided 20 dB gain and wide gain bandwidth. In this work hybrid telluride/silica fiber Raman amplifier is used for the configuration of amplifier. Moreover, different frequency bands are illustrated in the analysis of the system. S-band, C-band and L-band are the frequency bands. Channels with the speed of 10 Gbps in the system were analyzed. Total number of 8 WDM channels was used in the system. It was observed in the work that system covered link distance of 80 km with the Bit error rate of 10^{-11} . In this configuration of the amplifier Communication fiber optic model SMF-28 is used. Dispersion is reduced after the equalization function is used for the reduction of pulse. Fiber optic communication SMF-28 is used in the system and also there was use of equalization function for the reduction of pulse with size after dispersion.

Zhu *et al.* [32] presented the configurations of erbium doped and Raman fiber amplifiers. Connections of two amplifiers in the single unit and hybrid amplifier is used the work to support high data rate. Used of hybrid amplifiers covers the large wavelength array. Pumping of amplifiers in the optical fiber offers bit rate of 40 Gbps. Two type of

pumping such as co-pumping and counter pumping are analyzed in the system. Reduction in the distribution of scattering of Raman deteriorates the performance of the system. Raman fiber shows the better performance as compared to the erbium doper fiber. In this work the author use the 16 WDM channels and demonstrated the system link length of 400 km. Author in this work used the single pump with single frequency in Raman amplifiers. Low cost is realized in this system.

In 2002 Bolshtyansky *et al.* [33] proposed the large flat gain HOA that exhibited even gain in the array of wavelengths that ranging of 1610 nm - 1640 nm (falls under the long band). Furthermore the necessity of the more than single pumps in the optical amplification was put off and simply single pump of 1536 nm was employed to accomplish the desired goal. Evaluation of the systems came with the results that with the change in the physical parameters of the Raman amplifier, performance of the system will be enhanced.

In 2004 Zimmerman *et al.* [34] presented and demonstrated the study of gain flatness. There is use of different amplifiers to diverse gain flatness. Hybrid Al-co-doped with Al/P- co-doped EDFAs, Raman-EDFA HOA. Also they have studied the GFFs (gain flattening filters) are demonstrated in the WDM channels for better gain. It was observed from the evaluation of the system high quality gain is achieved over the array of wavelength and gain flatness is also observed. On the other hand, the cost effective of the system is low and the modules used in the system are pumps and filters.

In 2005 Lee *et al.* [35] proposed and evaluated the gain achieved and the noise figure. Use of hybrid optical amplifiers can achieve the high gain and no noise figure. Proposed of amplifiers like HOA in the system realized through the use of erbium fiber and Raman fiber. Dispersion compensation fiber in the system used as the Raman fiber to amplify the signals. Recycling of optical pump was used for the saving of the cost of the system. Use of recycled signal to erbium fiber (EDF) and residual pumping to fiber Raman amplifier (FRA) revealed the better performance of the system. For the diverse wavelength of pump sources DCF was introduced. However, the experimentation was done on the single

channel and gain flatness was not deliberated. Gain was achieved in this work using more number of channels.

In 1996 S.j.byooet al. [36] performed demonstrated the results of semiconductor optical amplifier. Tunable wavelength effects the FWM presented in the semiconductor optical amplifier. Use of the semiconductor optical amplifier supports the high data rates in the system. Many demonstration results are observed to simulate and bit rates of 2.5 Gbps as well as 10 Gbps are analyzed in the systems. Wavelength conversion and spectral conversion was reliant on time resolving in the system.

In 2007 Yasin M. Karfaaet al. [37] performed the degradation of channels in this work. Multiple channels systems like FWM affects the performance of degradation of systems. FWM effects are the effects based on Kerr's effect. The Ker's effect is derived by derived the mathematical analysis and validation of the FWM in the system. Results are analyzed by the bit error rate when the distance was varied under the effects of FWM.

In 2014 S Sugumaranet al. [38] demonstrated the work of wavelength division multiplexed system. This work was analyzed on the simulation software i.e. OptiwaveOptisystem software. The effects of the channel spacing in the WDM system were demonstrated in this work and the non effects are missing. In the WDM systems, the performance of FWM deteriorates the performance very carefully. By changing the length of the optical fiber in the system the effects were observed. Thus uneven frequency was used and also spaced in the WDM systems and it also lowers the effects of four wave mixing.

In 2010 R. S. Kaleret a.l [39] demonstrated the system with the use of single mode fiber-28 based system and was able to carry bit rate of 10 Gbps. To tolerate the dispersion effects different phase shift keying with return to zero was used and their dispersion effects was also tolerated by the system. Lower data rates such as 10 Gbps provides less performance deteriorating effects due to dispersion and self phase modulation. As there was increase in the data rate such that it approaches to 40 Gbps, effects of dispersion become worse. Tolerance of RZ-DPSK to SPM was disturbed at the data rate of 40 Gbps.

CHAPTER 3

RESEARCH GAPS AND OBJECTIVES

3.1 RESEARCH GAPS

The increasing in demands of internet services as well as multimedia services requires the greater quantity of information traffic in the network systems. The conventional data has surpassed due to the increase demands of the present systems. In near future, to compete with the problems like good internet services, amount of data rate communication and architectural design must be competent. This design should help in the good communication services and services like internet. Communication design, architectural design and Quality of Service necessities [45] [46] [47] competes the requirements of data. To attain the good performance systems and broadening amplification, complications in the system occur due to many networks or components used in the system. For the future generations fiber optic reliant systems are used for the distance communication, reducing crosstalk and the gain flatness. These are the main key features to demonstrate in the communication system [48]. The design of the amplifiers is more compatible. The amplifiers using now a days can tolerate the effects such as linear and non linear effects. In order to fulfill the demands of internet, high capacity systems are required in the system. However, C-band is used by many researchers for researches in the communication and researchers are now in a different way for another wavelength window. Long band comes out to be the solution for the requirements in the aforementioned problems. Thus, L-band EDFA is also required to amplify the long band wavelengths [49] [50]. But still the various undesired effects the low performance of the system.

Working by researchers in erbium doped fiber amplifier, this section elaborates the limitation in L-band amplifier along with the problems in C-band EDFA also. The most important differences between C-band as well as L-band EDFA's are demonstrated in this study. Backward power affects the pumping efficiency that is observed by the amplifier spontaneous noise. Also the noise figure can be observed in the amplifier spontaneous by the back pumping effects. On the other hand, signal induced inhomogeneous affected by the ASE power affects in long band amplifiers. [24], [25].

In the L-band gain is liable to temperature than C-band signals [28]. The two fundamentals actions are demonstrated to separate long-band thermal behavior from C-band actions. The effects i.e. thermal effects introduce the fluctuations in the output power and gain tilt also emerged in it. This output power is dependence on the thermal effects at 980 nm and 1480 nm are least or they can be independent in case of C-band.

3.2 PROBLEM FORMULATION

First From literature survey, we came across through different approaches to address the limitations in optical amplifiers. The problems occurred in the practical systems urge us to look forward solutions in the communication field. For attaining the maximum gain and gain flatness approaches is done the practical systems.

Problems formulation in L-band amplifiers:

- ✓ Low Gain
- ✓ High noise figure
- ✓ High Gain variance in C+L band EDFA's
- ✓ More prone to thermal effects
- ✓ More transient effects
- ✓ Multiple stages required for amplification
- ✓ Use of costly components such as GFFs
- ✓ Long EDF fibers are needed

Proposals to overcome above mentioned issues are given below:

- To design a high Gain long-band EDFA amplifier, effective use of amplified spontaneous noise as a source to enhance gain by the process of reinjection in EDF fiber through the incorporation of FBGs.
- Various physical parameters of the EDF fiber and pumps are needed to be investigated so that the performance of system could be enhanced. These parameters may also provide the performance of longer distances in the systems.

- To incorporate the cost effective components like gain flattening filters, isolators, and amplifiers increases the cost of system. Gain flatness in the L-band by using the EDFA amplifiers is key limitation.

3.3 RESEARCH OBJECTIVES

The following are the research objectives:

1. To study and analyze different physical parameters of L-band EDFA with ASE reinjection.
2. To design fiber optic communication system to check the performance of different line codings in L-band ASE reinjected amplifier.
3. To propose low cost gain flattening of L-band with multiple FBGs and ASE reinjection.

CHAPTER 4

PROPOSED METHODOLOGY, RESULTS AND DISCUSSIONS

4.1 INTRODUCTION

In this chapter, we investigated the proposed objectives, results are analyzed in terms of Gain, Q factor, noise figure and gain flattening. Different physical parameters such as radius of core, length of erbium (Er) doped fiber, meta stable life span of (Er) doped fiber, wavelength of pump, power of selected pump, pumping technique such as co-pumping, counter pumping, bidirectional pumping are studied to demonstrate the theory. Transmission distance of optical fiber and Q factor is varied in this study. For the gain flattening of long band erbium doped fiber amplifier work is done. 16 channel laser source is demonstrated in the system. To use a limitation of amplifier spontaneous noise in the gain enhancement of L-band amplifier flattens of gain is enhanced. And also the use of fiber bragg grating in the system flattens gains of the system. There is a comparison of proposed work and reported work is also carried out in the last work. Conclusion are drawn based on the results of the aforementioned work along with the future of the L-band EDFA.

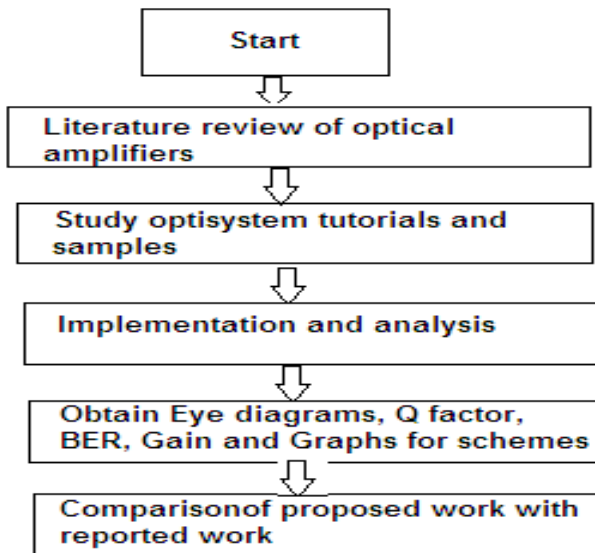

Figure 4.1 Research Methodology of Work

4.2 OPTISYSTEM OVERVIEW

Optisystem is software that is used to design the optical communication system simulation. The optical designs test and optimization is done using the Optisystem software. It is a simulation model that can simulate the modeling of the FOC. In the Optisystem software there are different components i.e. active and passive components are included in the library of the Optisystem software. To investigate the effects and analyze the different devices, different parameters can be changed according to their requirements or their system performance. Optisystem calculates the readings with the change in their parameters. Objectives will be written for the solution of problems. Modeling of the designs can be using Optisystem software using tool for simulation. Data flow model can be addressed using the Optisystem software and the simulation of transmission layer can also be analyzed. Different analyzing techniques can be analyzed for the system if there would be limited by the noise and the inter symbol interference. Evaluations will be done in terms of Q factor, Gain, noise figure etc.

4.3 PERFORMANCE ANALYSIS TO ENHANCE THE GAIN FLATNESS OF L-EDFA IN 16 CHANNEL WDM SYSTEMS WITH MULTIPLE FBGs

As the demand of data is increasing day by day so the large number of channels is required and therefore with the ASE reinjection, gain can be enhanced. The setup is demonstrated and different setup use the different techniques such as for Gain enhancement like ASE reinjection and different line codings. Further the parameters are analyzed of ASE with the change in EDFA length, core radius, input power and Gain and Noise figure are also analyzed. Different line coding techniques such as NRZ and RZ are also used for the enhancement of gain for longer distance, data rate, Q factor and eye diagram. After the low cost gain flattening of L band with multiple FBGs and ASE reinjection are demonstrated. Further the study of the different objectives with the simulation parameters and their set up are demonstrated. This chapter consists of various sections that are organized into the different sections and their study. At the end performance is enhanced with the gain flatness of L-band EDFA in WDM system and also can be used for longer distance communication.

4.3.1 Simulation Setup

(a) To investigate the different physical parameters of L band EDFA with ASE reinjection

System Setup

In this experimental work, two fiber bragg gratings with amplified spontaneous reinjection are used to proposed a bidirectionally pumped long band erbium doped fiber amplifiers as shown in Figure 4.2 10 Gbps speed of the operation is fixed from binary data bits generator. Wavelength 1570 nm and a continuous wave power laser at -45 dBm are incorporated in the system and is acting as L-band source. To prevent the laser from the back flowing optical intensity due to the ASE, laser signal is passed through the optical isolator. A laser signal and a pump 1 at 974 wavelengths both are fed to the optical co-propagating pump coupler. FBG1 is connected with the pump1 and acting as the reflector of backscattered ASE signal at 1565 nm. 1565 nm wavelength is selected to be reflected because at this point maximum intensity is achieved. 200 ms (Meta stable) lifetime of erbium doped fiber is taken. Physical parameters such as length of the EDF, core radius, input power and doping radius are varied. In table 4.1 different simulations are shown and proposed work is observed to clear the factors.

Table 4.1: Simulation of the Different Parameters of L-band EDFA

Parameters	Values
Laser Source	Tunable laser source
Power and Wavelength	-45 dBm and 1570 nm
Speed of Data	10 Gbps
Number of FBGs to Reinject ASE	2
EDF Fiber Length	varied from 5m to 35 m
EDF Core Radius	varied from 0.7 um to 1.9 um
Input Power	varied from -55 dBm to 5 dBm

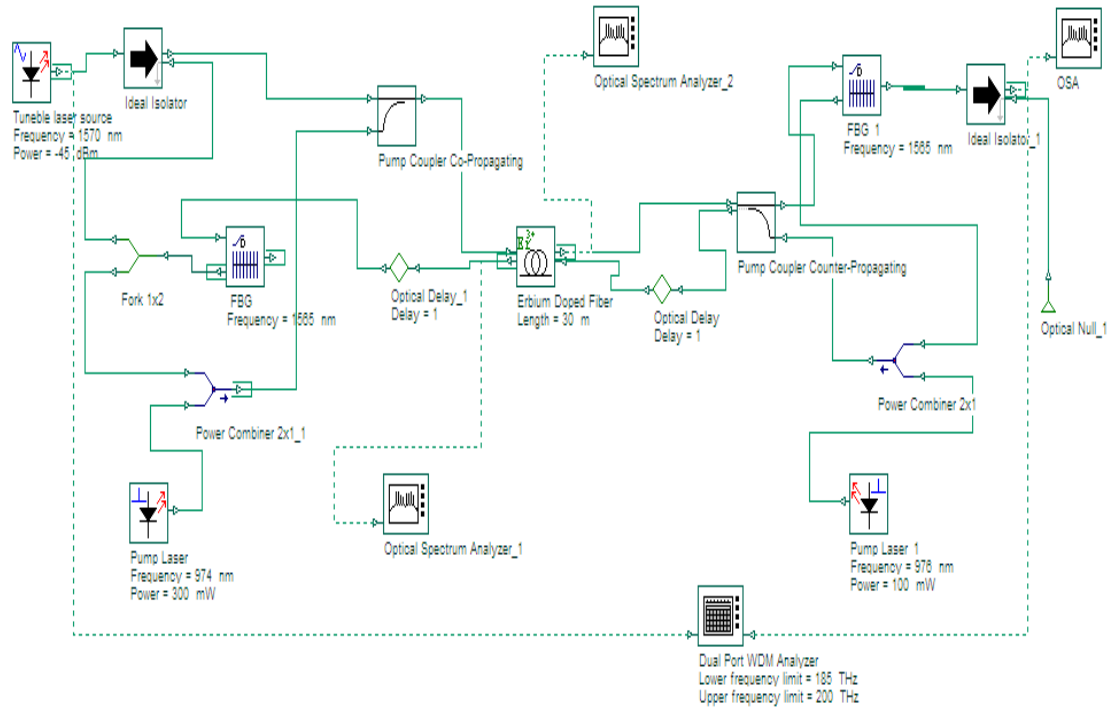

Figure 4.2 Setup Simulation of Proposed L-band EDFA

EDF output power is fed to the coupler i.e. counter propagating coupler and the wavelength 976 nm of the pump power 2 is combined here. To reflect the forward scattered amplified spontaneous noise the FBG 2 is employed to it and pump2 is combined with the power. Finally through the isolator the signal is passed and the dual port WDM analyzer accessed the signal gain.

(b) To carry out the research performance of different line codings in L-band ASE reinjection amplifier

In this work, at the incorporating link lengths of single mode fiber (SMF-28) in the terms of BER and Q factor different pulse shapes are observed in the analysis of long band erbium doped fiber amplifier system.

Theory of NRZ and RZ

Modulation is defined as the information contents are superimposed of the modulated signal in a carrier signal (of high frequencies) the carrier signal characteristics is varying

according to the modulating signal. There are different range of modulating signal schemes and can be classified as

Non-Return-to-Zero On-Off Keying (NRZ-OOK)

NRZ (non-return-to-zero) is relate to the transmission i.e. digital data transmission in which there are binary states such as binary low and binary high are represented by the digits 0 and 1. This digital data 0 and 1 is transmitted by the voltages that are specified and constant DC (direct-current) voltages. In the positive-logic NRZ, the lower state is pointed as the less positive voltage or the more negative voltage and the more positive voltage or the less negative is represented in the high state. In the negative-logic NRZ the lower state is pointed as less negative voltage or more positive voltage and the more negative voltage or the less positive voltage is represented in the high state. In the communication systems the modulation is leading and also leads to the bandwidth efficient line coding. In this formats there are the various advantages such as these are not liable to the laser phase noise and efficient spectrum for longer distances communications are provided. NRZ linecoding is simple and practiced so far because of their cost effectiveness. NRZ waveforms are depicted and is illustrates in the Figure 4.3

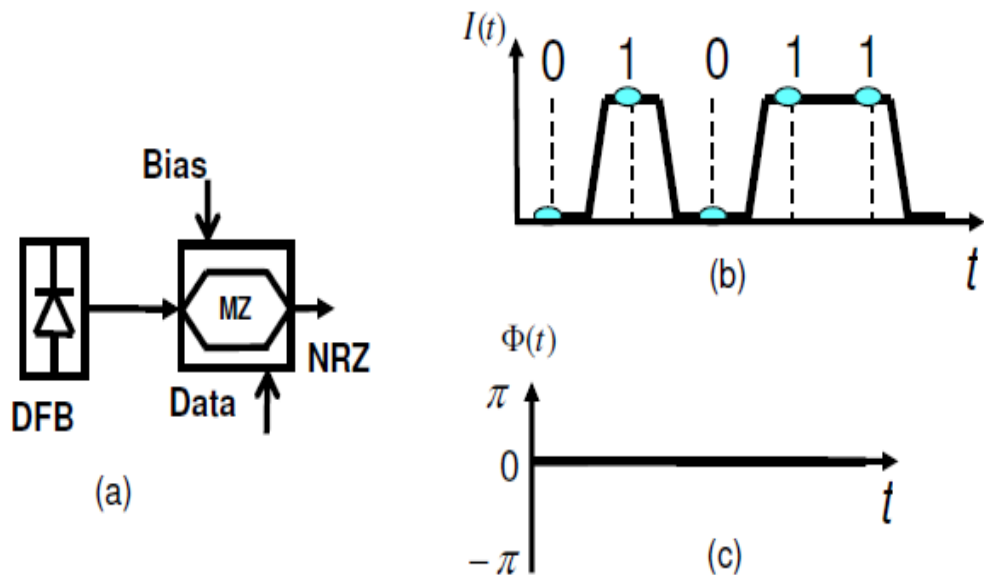

Figure 4.3 Modulation Scheme of NRZ (a) NRZ Transmitter (b) Waveform for Intensity $I(t)$ and (c) Phase $\Phi(t)$

Return-to-Zero On-Off Keying (RZ-OOK)

RZ (return-to-zero) is defined as the formation of digital data transmission in which there are the states namely the binary low and the high state. These states are represented by the digital numbers 0 and 1 and these digits having specific characteristics and are transmitted by voltage pulses.

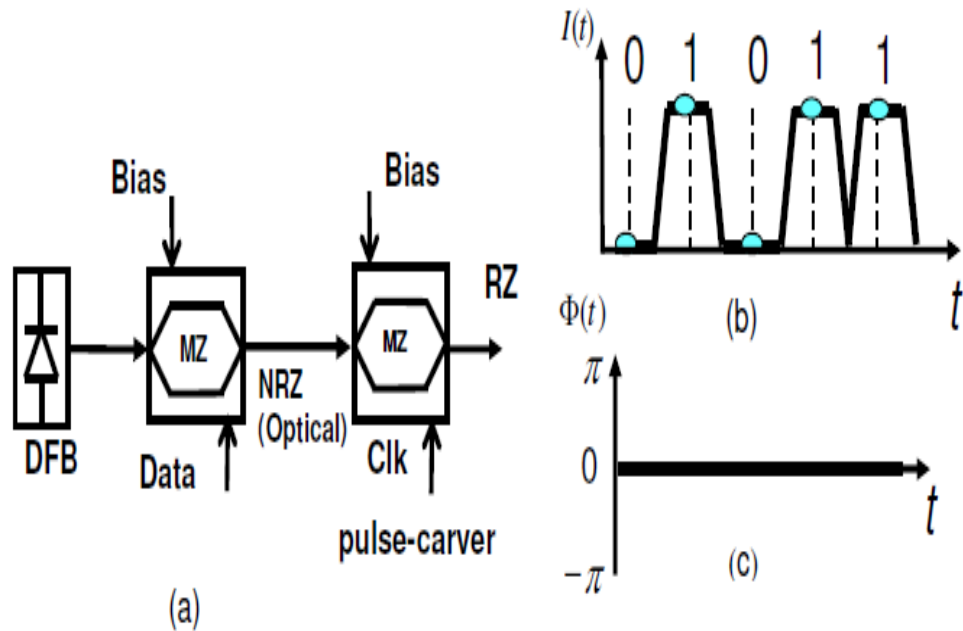

Figure 4.4 RZ Modulation Scheme: (a) Block Diagrams of RZ Transmitter (b) Waveform for Intensity $I(t)$ and (c) Phase $\Phi(t)$

During the first half of each data binary digit the signal state is determined by the voltage. During the second half of each bit the signal returns to the resting state also called the zero state. The resting state is of zero volts although this resting state does not have to be. RZ modulation having advantage that in optic fiber communication it is more tolerant to non linear effects. However without any pulse carver RZ modulation is generated directly but more space is acquired by the RZ pulse format. So this is not efficient to the bandwidth.

System Setup

In this work, the transmission characteristics of the proposed long band EDFA amplifier are analyzed. An optical fiber standard SMF-28 is selected for the designing of L band

single stage erbium doped fiber amplifier to evaluate the system performance. In the form of block diagram the system setup is shown in the Figure 4.5 0.3 dB per kilometer attenuation is observed in the single mode fiber and 17 ps per nm per kilometer attenuation is observed in the pulse broadening. To get the close results of practicals all the non linear effects are kept on.

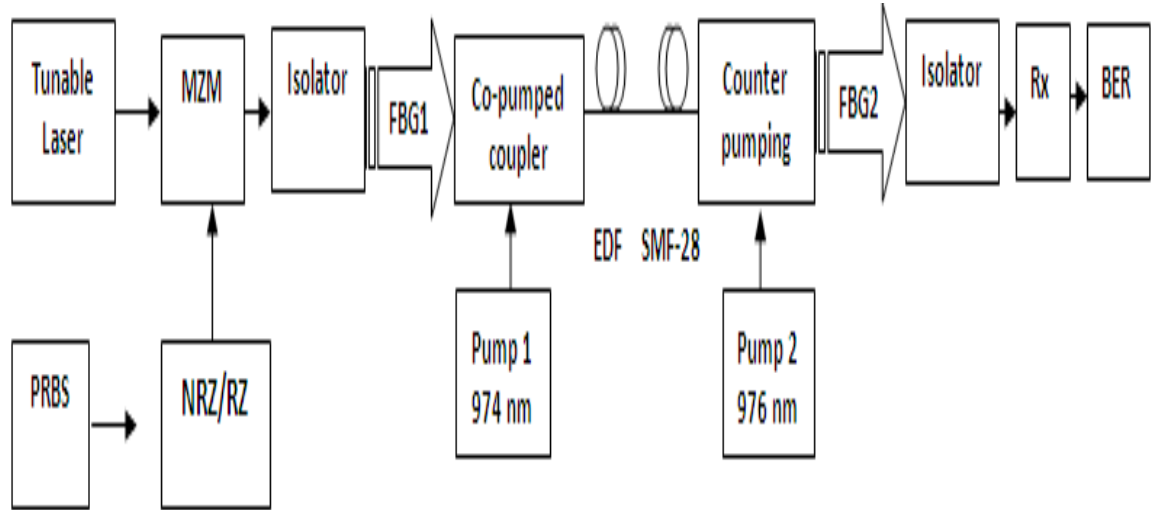

Figure 4.5 Proposed L-band EDFA System for NRZ and RZ

For the generation of binary data bits pseudo random bit sequence generator at 10 Gbps data rate is employed in the system. Shaping pulse of the Non return to zero and Return to zero is done of the binary data. Electrical data to optical data conversion (E/O) modulator is investigated in the system which obtains from the NRZ/RZ and laser signal. Two fiber bragg gratings is used with the amplified spontaneous reinjection, the bi directionally pumped long band erbium doped fiber amplifiers are demonstrated in it. Wavelength of 1570 nm and a tunable laser source at -45 dBm are included in the system and these laser source and wavelength act as L-band source. To prevent optical laser source from the back flowing optical intensity due to ASE, laser signal is made to pass through the optical isolator. A pump 1 at 974 nm wavelength is coupled to the optical co-propagating pump coupler and laser signal is also fed to the optical co-propagating pump coupler. Here FBG1 is combined with the pump 1 and is also acting as the reflector of back scatters ASE signal at 1565 nm. Output of EDF fiber is fed to the counter

propagating coupler and pump 2 power at wavelength of 976 nm is also combined here. Pump 2 is combined with the power and FBG 2 is demonstrated to reflect the forward scattered amplified spontaneous noise. Through the isolator signal is passed and with the dual port WDM analyzer signal gain is accessed and at the receiver it is followed by the BER analyzer. The receiver consists of low pass filter and the photo detector. Table 4.2 depicts the simulation parameter.

Table 4.2 Simulation Parameters of Different Line Codings

Parameters	Values
Data Rate	10 Gbps
Optical Fiber	SMF-28
Formats of Modulation	Non return to zero, return to zero
Distance	10 km to 70 km
Attenuation	0.2 db/km
Dispersion	17 ps/nm/km
Nonlinear Effects	SPM,FWM,XGM,XPM
Power of Pump 1	300 mW
Power of Pump 2	100 mW
Input Power form Laser	-45 dBm

(c) To put forward a low cost gain flattening of L-band with multiple FBGs and ASE reinjection

In this experimental study, to enhance the gain flatness investigation of L-band single stage EDFA amplifier is done. The expensive components such as gain flattening filters and isolators are used until for gain flattening in L band. To reduce the cost effectiveness FBGs are used in the ASE reinjection of L-band EDFA. 16 channels are multiplexed in

the wavelength division in L-band window. Gain flatness of 1.23 dB is observed using the demonstrated method.

Introduction

In the communication system there is increase in the demand for large bandwidth for sending the maximum data or information signal at the rapid speed. The demand of higher bandwidth is solved by the technology of optical communication. Due to the presence of nonlinearities signal degrades as the transmission distance is increased in the optical fiber. So optical amplifiers come in the demands that provide better performance for the WDM system. We need a type of amplifier which can directly amplify signal in optical domain as if the signal travels in the optical domain. These types of amplifiers are used to amplify the signal called the optical amplifier. The optical amplifiers are EDFA, RAMAN, Hybrid optical amplifiers, Semiconductor optical amplifier etc. But wide band erbium doped fiber amplifiers are the amplifiers which are very popular now days. The mathematical model which is of two dimensional i.e. time and wavelength, WDM system works on it also on the characteristics of physical layer impairments and discrete time. The transmission of the observable light signals over optical fiber cable for large distance is defined as the long-haul optics. The minimum use of repeaters or the system requires primary repeaters with the minimal use should be functional. In fiber optic cable to remain the signal quality from weakening to the non usability point, normally repeaters are required after some distance. The main objective in the long-haul communication is to keep the number of repeaters less as per unit distance as well as unnecessary number of repeaters. Wide bandwidth and operation of low cost is provided by the L-band EDFA amplifiers and this comes to an ultimate solution. When the large number of wavelengths passed through the amplifier gain flattening is the main issue. To address the issues many come forward to report these but they are cost effective and also increase the capacity of the system.

In this experimental work, by using a low cost FBG (fiber bragg grating) in L band EDFA an enhanced gain flattening in L band WDM system is analyzed. The work done and analyzed in this work is the comparison of with and without FBG. The output gain and flatness are evaluated in the similar criteria.

System Setup

In this work, to improve the gain flatness the main focus is done on the design of L band single stage erbium doped fiber amplifier. To analyze the gain and gain flatness over L band different physical parameters of EDFA amplifier are investigated. Block diagram of WDM systems in Figure 4.6 is shown. To improve the gain flatness work is done in the WDM system. In the multiplexer WDM transmitter composed of 16 wavelengths (1569.7 nm-1579 nm) in L band is fed into it. It is studied from the aforementioned investigation that L band wavelengths are not amplified by the single EDFA amplifier same as C band. A new method is observed the flatness of gain varied and also the improve of gain flatness. After the multiplexer with certain frequency 1571 nm and bandwidth of 4 THz, the frequencies that are amplifier EDFA to the greater extent are reflected by the FBG. FBG consist of 3 ports namely the input port, transmitted port and the reflected port. The wavelength frequencies are set that is to be transmitted and also the bandwidth of reflected wavelengths.

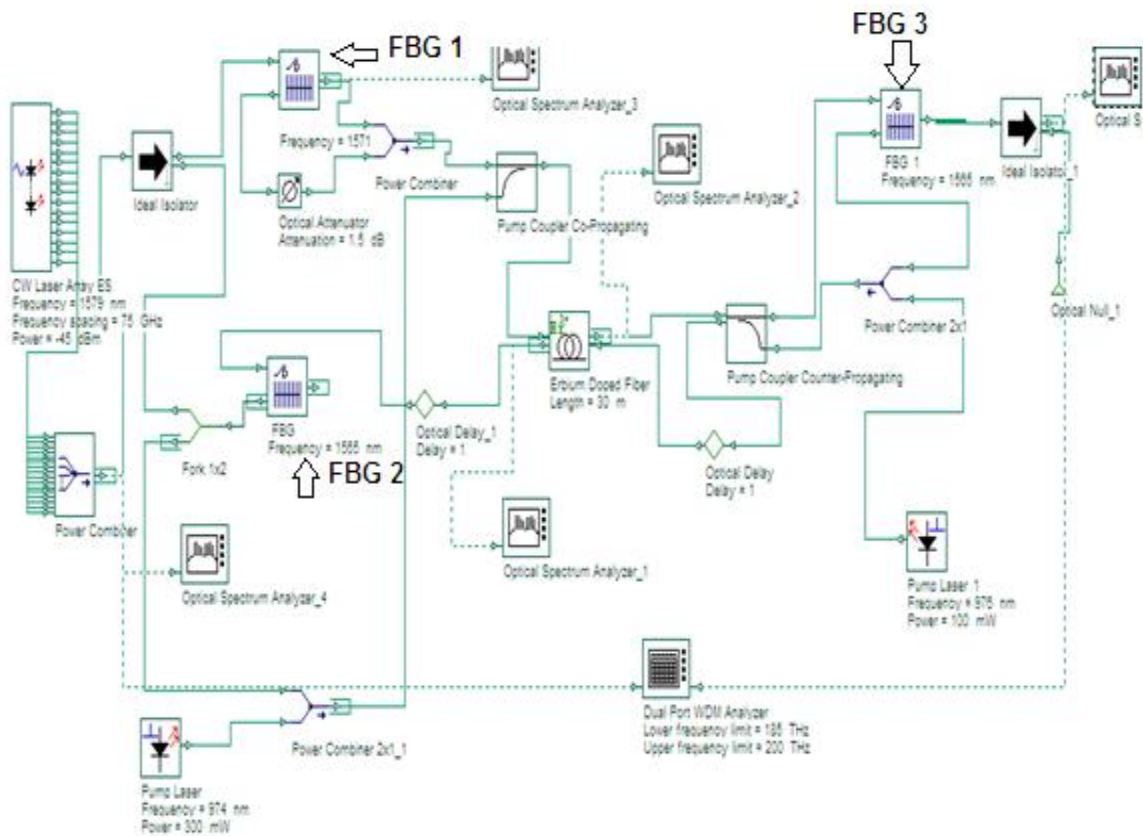

Figure 4.6 Representation of 16 Channel L-band EDFA System

Through the attenuator the reflected wavelengths are attenuated and after the attenuation the transmitted wavelengths are combined again. Firstly to the EDFA the combined signal is fed into it and then results are analyzed. Two fiber bragg gratings with amplified spontaneous reinjection are used to demonstrate the bidirectional pumped long band erbium doped fiber amplifiers. To prevent the signal from the back flowing optical intensity due to the ASE optical isolators are used and the signal are made passed through this isolator. Pump 1 at the wavelength of 974 nm is coupled to the co-propagating pump coupler and laser signal is fed to this module. FBG 2 is combined with the pump 1 and also FBG 2 act as the reflector of backscattered ASE signal at 1565 nm. Power of the pump 2 at the wavelength of 976 nm is combined and the output of EDF fiber is fed with the counter propagating coupler. To reflect the forward scattered amplified spontaneous noise FBG 3 is used and pump 2 is combined with the power. At the end through the isolator the signal is passed and by the dual port WDM analyzer gain of signal is accessed.

4.3.2 Results and Discussions

Objective 1 Results

In this experiment simulation results are analyzed for the various parameters of erbium doped fiber amplifier (EDFA) and also the parameters of wavelength division multiplexing. Different physical parameters such as radius of core, length of erbium (Er) doped fiber, meta stable life span of (Er) doped fiber, wavelength of pump, power of selected pump, pumping technique such as co-pumping, counter pumping, bidirectional pumping are done to analyze the results of the experiment. The technique used for gain enhancement is the ASE reinjection.

In the given below Figure 4.7 depict the performance of L-Band ASE reinjection amplifier at input power and output power as gain as well as noise figure has been analyzed. It is observed that without the ASE reinjection the gain is increasing with the increase in the input power however after -15 dBm of input power the gain starts decreasing slightly.

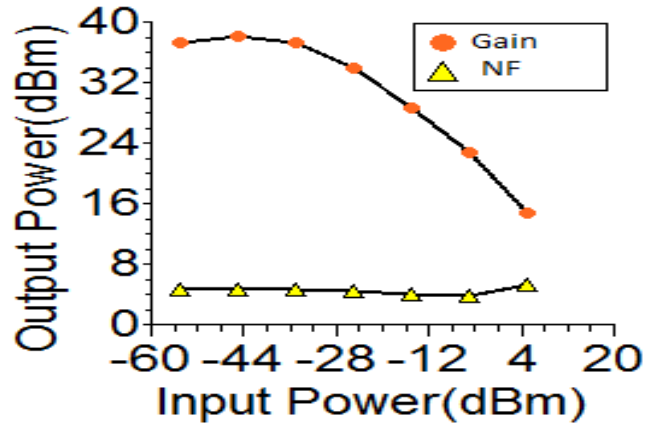

Figure 4.7 Gain and Noise Figure Spectrum of Erbium Doped Fiber Amplifier (EDFA) According to the Input Power

In the given below Figure 4.8 depicts the performance of L-Band ASE reinjection amplifier at input power. The forward and backward ASE has been analyzed. It is observed that with the increase in the input power the forward ASE is decreasing and the backward ASE is slightly decreasing; however, after the -5 dBm, it gets decreased. So it is analyzed that backward ASE is found to be more optimal.

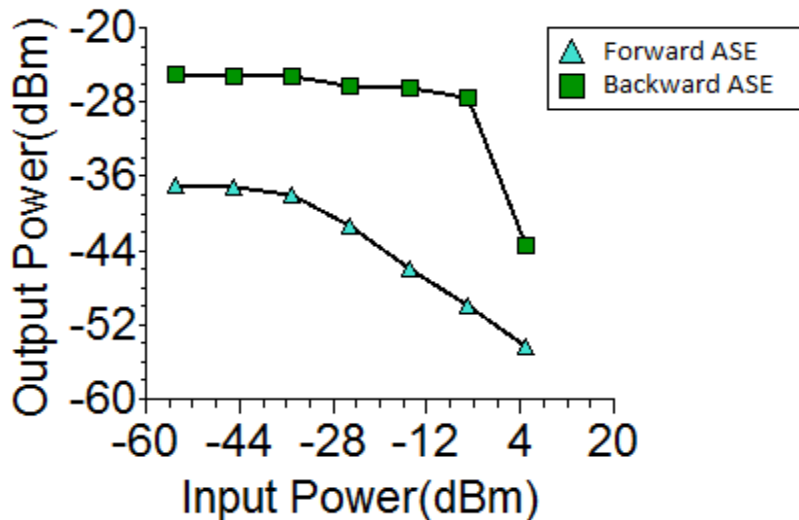

Figure 4.8 Shows the Forward and Backward ASE Results (dBm)

It can be seen in the given below Figure 4.9, after the backward and forward pumping of erbium doped fiber the gain and noise figure is again analyzed and therefore we analyzed that with the increase in the input power the gain and noise figure fluctuates both with the minimum parameters but at the input power of 5 dBm the gain decreases up to 12.32 and the noise figure is approximate 6.76 dBm.

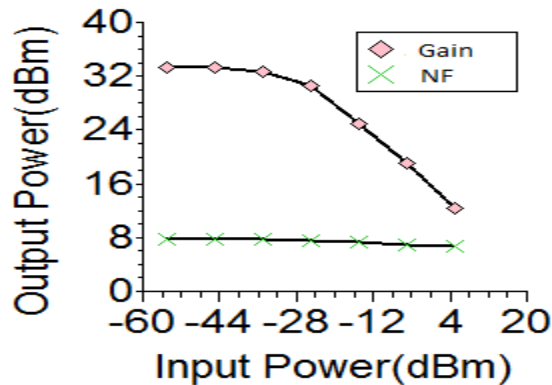

Figure 4.9 Shows the Results of Gain and Noise Figure (dBm) After the Forward and Backward ASE

In the given below Figure 4.10 depict the performance of L-Band ASE reinjection amplifier at varied lengths of EDF fiber and gain as well as noise figure has been analyzed. It is observed that with the increase in the EDFA length gain of the amplifier increases however after 35 km gain starts decreasing slightly so 35 km length of L band EDFA is found out to be optimal.

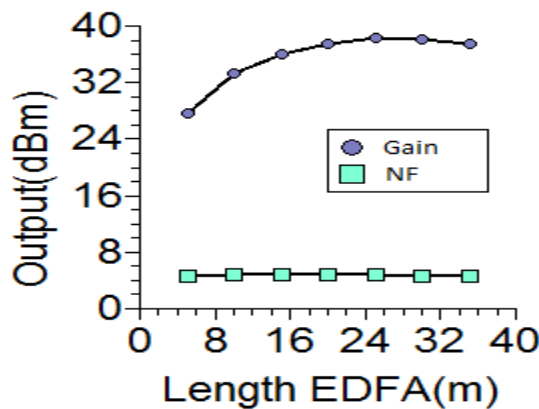

Figure 4.10 Length of Erbium Doped Fiber Versus Output Power After ASE Reinjection

In the given below Figure 4.11 depict the performance of L-Band ASE reinjection amplifier at varied core radius of EDF fiber and gain as well as noise figure has been analyzed. It is observed that with the increase in the core radius gain of the amplifier increases however after 1.9 μm gain starts decreasing slightly so 1.7 core radius of L band EDFA is found out to be optimal.

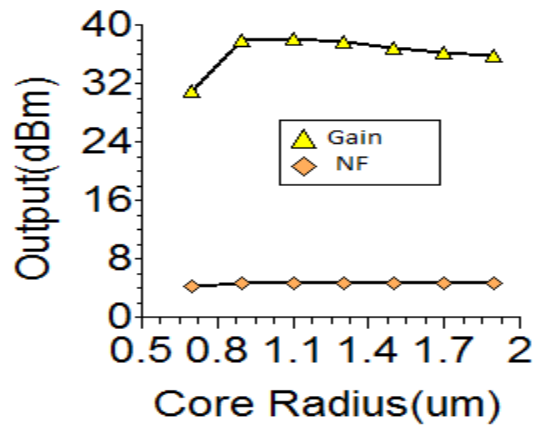

Figure 4.11 Core Radius (μm) Versus Output Power (dBm)

In the given below Figure 4.12 depict the performance of L-Band ASE reinjection amplifier at varied lengths of EDF fiber and gain as well as noise figure has been analyzed. It is noticed that with the increase in the EDFA length gain of the amplifier increases however after 25 km gain starts decreasing slightly so 25 km length of L band EDFA is found out to be optimal.

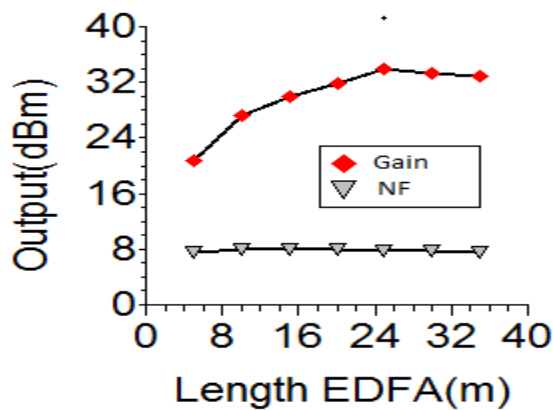

Figure 4.12 Length of EDFA (m) Versus the Output Without ASE Reinjection

In the given below Figure 4.13 depicts the performance of L-Band ASE reinjection amplifier at varied core radius of EDF fiber and gain as well as noise figure has been analyzed. It is observed that with the increase in the core radius gain of the amplifier increases however after 1.9 μm gain starts decreasing slightly so 1.7 μm core radius of L-band EDFA.

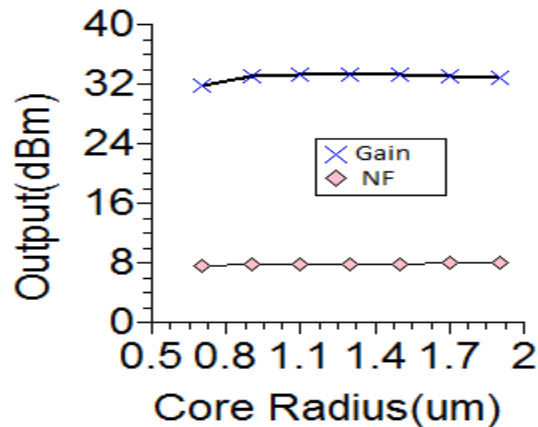

Figure 4.13 Core Radius (μm) Versus Output Power (dBm)

Objective 2 Results

In the given below the experimental simulation results are shown. The different parameters of line codings in L band ASE reinjected amplifier.

In the given below Figure 4.14 depict the performance of different line coding in L-Band ASE reinjection amplifier at distance of optical fiber and BER analyses of NRZ and RZ are varied. It is noticed that with the increase in the distance BER of NRZ is better than the RZ. However the NRZ performance is better than the RZ coding.

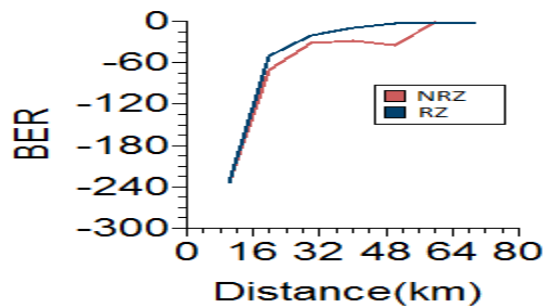

Figure 4.14 Distance (km) Versus BER

In the given below Figure 4.15 depict the performance of different line coding in L-Band ASE reinjection amplifier at distance of optical fiber and Q factor analyses of NRZ and RZ are varied. It is noticed that with the increase in the distance, performance of Q factor of NRZ is better than the RZ. However, the NRZ performance is better than the RZ coding.

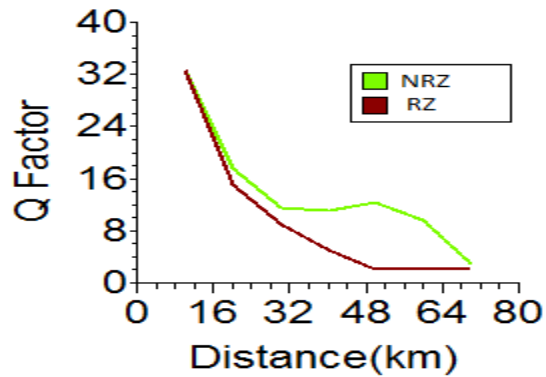

Figure 4.15 Distance Versus Q Factor

In the given below Figure 4.16 depict the performance of different line coding in L-Band ASE reinjection amplifier at received power and SNR analyses of NRZ and RZ are varied. It is observed that with the decrease in the distance the performance of SNR of NRZ is better than the RZ. However, the NRZ performance is better than the RZ coding.

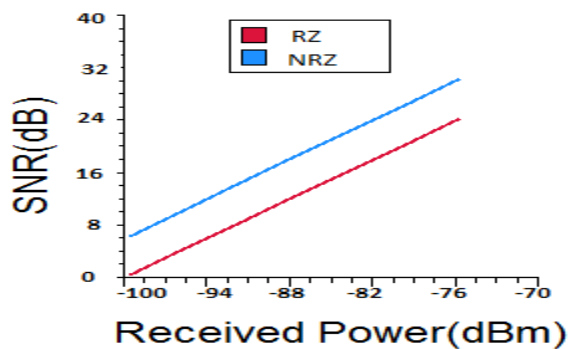

Figure 4.16 Graph Plotted Between the Received Power (dBm) and the SNR (dBm)

Objective 3 Results

In the given below the experimental simulation results are shown. The gain flattening is achieved by different wavelength and FBGs.

In the given below Figure 4.16 depict the performance of low gain flattening of L-Band analyses of NRZ and RZ with the different wavelengths. It is observed that gain with flatness is better than the without flatness.

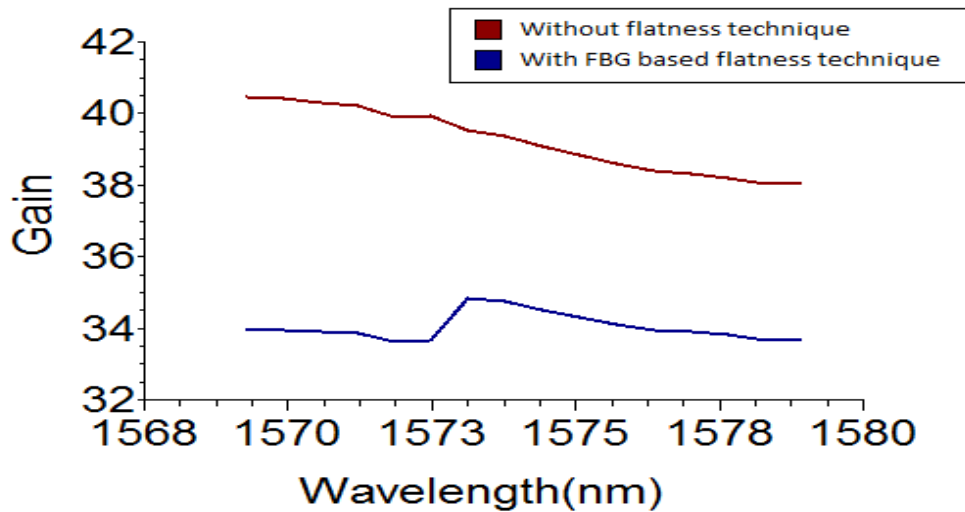
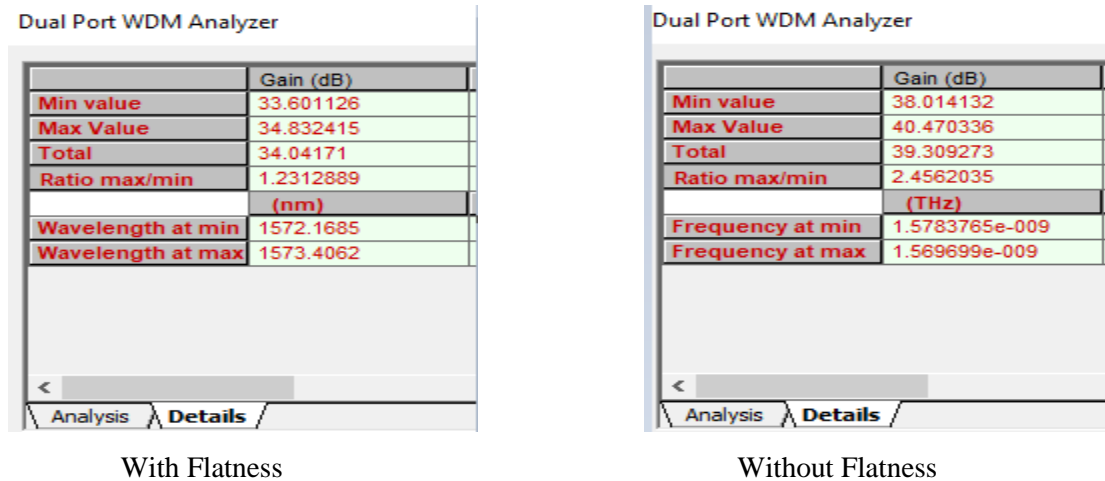

Figure 4.17 Graph Depicts the Gain With and Without Flatness Technique

CHAPTER 5

CONCLUSIONS AND FUTURE SCOPE

5.1 CONCLUSIONS

It is concluded that in the study of the different physical parameters of L-band EDFA with ASE reinjection, two fiber Bragg gratings with amplified spontaneous reinjection are used and also the bidirectional pump L-band EDFA. This work proposed with the wavelength of 1570 nm and a power laser of -45 dBm. An isolator i.e. optical isolator is used to prevent the laser from back flowing intensity of optical which is due to ASE. It is concluded that with the change in the different parameters of length of the EDF, core radius, input power and doping radius the better results performance are varied. It is concluded that maximum gain is achieved but the gain is not flat. After the third stage we attain the satisfactory gain with the flatness.

To increase the gain SMF in terms of BER and Q factor are analyzed in L-band EDFA and incorporated with the different link lengths and the different pulse shapes are used such as RZ and NRZ. Also NRZ are better than RZ and NRZ line coding is not liable to the laser phase noise. It is concluded that with these analyses that signal gain is accessed and efficient spectrum is provided for longer distance communication the observation can be accessed through BER analyzer. It is clear from the results that use of line coding such as NRZ upgrades the gain performance for longer distance communication.

It is concluded that the low cost gain flattening of L-band with multiple FBGs and ASE reinjection. 16 channels multiplexing are used in the wavelength division in L-band. It is also concluded with use of multiple FBGs the in the Gain flatness of 1.23 dB is observed and also cost effectiveness are reduced with the use of FBGs in ASE reinjection of L-band EDFA.

Investigation of performance analysis to enhance the Gain Flatness of L-EDFA in 16 Channel WDM System with Multiple FBGs is done. It is found that different parameters of length of the EDF, core radius, input power and doping radius are varied the better maximum gain is achieved. Further it is investigated that using of different line codings such as NRZ and RZ and NRZ raised with the better result performance as BER and

Qfactor over long distance. Further gain flatness is investigated with the use of FBGs and 16 wavelengths (1569.7 nm-1579 nm) in L-band.

5.2 FUTURE SCOPE

This thesis work is analyzed with 16 channels, as the demand of data is increasing day by day so we require the large number of channels, as 16 numbers of channels is considered in this work and we can also use large number of channels in the future for fulfill the demand of data requirement. The setup is demonstrated with the frequency of 100 GHz so to increase the bandwidth efficiency we can set the frequency less than 100 GHz and make the system analyze better. We have done the line coding NRZ and RZ and for the further modulations such as Quadrature Phase Shift Keying (QPSK), Differential Phase Shift Keying (DPSK) and Orthogonal Frequency Division Multiplexing can be used. Amplified spontaneous emission is used in this work but we can also use the C+L band can be made through reinjection and gain enhancement can be done.

REFERENCES

- [1] Sharma Hari Bhagwan, Gulati Tarun and Rawat Bharat (2012). Evaluation of Optical Amplifiers, International Journal of Engineering Research and Application, 2(1),(ISSN: 2248-9622), 663-667.
- [2] Kumar N. Sivarajan, The Optical Transport Network Revolution, Chennai: Networking Workshop 2, 2010.
- [3] Mukherjee. Optical WDM Networks, New York Springer (2006).
- [4] Agrawal G.P. *Fiber Optic Communication Systems*. New York: John Wiley and Sons, 1997.
- [5] Dutta Achyut K, Dutta Niloy K, Fujiwara Masahiko, *WDM Technologies Optical Networks*, Volume III, Elsevier Academic Press, 2004.
- [6] Sivarajan K.N , The Optical Transport Network Revolution, Chennai Networking Workshop 2, 2010.
- [7] Mukherjee Biswanath (2000), WDM optical communication networks: progress and challenges, *IEEE journal on selected areas in communications*, 18(10), 1810-1824.
- [8] Warren Don and Moore Justin, Multiplexing in Fiber Optic Connections, Summer Ventures in Science and Mathematics, 2001.
- [9] Senior J.M. Optical Fiber Communications. New York: Prentice Hall, 1992.
- [10] Downie J. D, Hurley J, Ten S, Towery C, Sharma M, Mauro Y, Malouin C, Zhang B, Bennike J, Schmidt T. and Saunders R. (2010), *DWDM 43 Gbit/s DPSK transmission over 1200 km with no inline dispersion compensation*, *Electronics Letters*, 46(1) ,60-62.
- [11] Lam Cedric F. *Passive Optical Networks- Principles and Practice*, Elsevier

Science and Technology, 2007.

- [12] *The principles of semiconductor laser diodes and amplifiers analysis and Transmission Line Laser Modeling*. Singapore: Imperial College Press, 2004.
- [13] Singh Y. N, Gupta H. M and Jain V. K. (1997), Semiconductor optical amplifiers in WDM tree-net, *IEEE Journal of Lightwave Technology*, 15(2), 252-260.
- [14] Ghafouri-Shiraz H, *The Principles Of Semiconductor Laser Diodes And Amplifiers*, London: Imperial College Press, 2004.
- [15] Malhotra Yugnanada, Kaler R.S (2012), Optimization of Super Dense WDM Systems for capacity enhancement, Elsevier, *Optic- International Journal of Light and Electron Optic*, 123(16), 1497-1500.
- [16] Rieznik A.A, H.L, Fragnito, Costa e Silva M.B, Von der Weid J.P (2006), Study on optimum fiber length for maximum gain in C and L –band EDFAs, *Elsevier, Optical Communications*, 266(2), 546-551.
- [17] Nagaraju B, Paul M.C, Pal M, Pal A, Varshney R.K, Pal B.P, Bhadra S.K, Monnom G. and Dussardier B (2009), Design and fabrication of an intrinsically gain flattened Erbium doped fiber amplifier, *Journal of Optics Communication*, 282(8), 2335–2338.
- [18] Choi H, Oh J, Lee D, Ahn S, Park B. and Lee S (2002). Simple and efficient L-band erbium-doped fiber amplifiers for WDM networks, *Optics Communications*, 213(1-3), 63-66.
- [19] Behera J. K. and Shevgaonkar R. K (2004) Optimal Design of Raman Amplifier, in *Photonics*, pp. 113-116.
- [20] Rottwitt K, Povlsen J.H. (2005), Analyzing the fundamental properties of Raman amplifiers in optical fibers, *Journal of Lightw. Technology*, 23(11), 3597-3613.
- [21] Headley C. and Aggrawal G.P, *Raman Amplification in Fiber Optic Communication Systems*, California: Academic Press, 2005.

- [22] Sudo S., *Optical Fiber Amplifiers: Materials, Devices, and Applications*, (Artech House Optoelectronics Library), Artech House, 1997.
- [23] Mohammed N. Islam, *Raman Amplifiers for Telecommunications-1 Physical Principles*, Springer, 2004.
- [24] Agarwal G. P, *Fiber-Optic Communication Systems*, New York: John Wiley and Sons, 2002.
- [25] Borella M.S, Jue J.P, Banerjee D, Ramamurthy B and Mukherjee B (1997), *Optical Components for WDM Lightwave Networks*, Proc. of the IEEE, 85(6), 1274- 1307.
- [26] Tachibana M, Laming R. I, Morkel P. R and Payne D. N (1991) , Erbium-Doped Fiber Amplifier with Flattened Gain Spectrum, *IEEE Photonics Technology Letters*, 3(2), 118-120.
- [27] Durak Fırat Ertuğ, Altuncu Ahmet (2017), The effect of ASE reinjection configuration through FBGs on the gain and noise figure performance of L-Band EDFA, *optics communications*, 386, 31-36.
- [28] Masuda H, Kawai S. and Aida K (1998). Ultra-wideband hybrid amplifier comprising distributed Raman amplifier and erbium doped fiber amplifier, *IEEE Electronic Letters*, 34(13), 1342-1344.
- [29] Kawai S , Masuda H , Suzuki K. and Aida K (1999) , Wide-bandwidth and long-distance WDM transmission using highly gain-flattened hybrid amplifier, *IEEE Photonics Technology Letters*, 11(7), 886-888.
- [30] Zhu B, Leng L, Nelson L.E, Qian Y, Cowsar L, Slulz S, Doerr C, Stulz L, Chandrasekhar S, Radic S, Chen D, Vengsarkar. Z, Park J, Feder I C.S, Thiele H, Bromage J, Nielsen L. Gruner and Kiiudsen S (2001). 3.08 Tbit/s (77 x 42.7 Gbit/s) WDM transmission over 1200 km fiber with 100 km repeater spacing

using dual C- and L-band hybrid Raman/erbium-doped inline amplifiers,*Electronic Letters*, 37(3),844-845.

- [31] Masuda H, Mori A, Shikano K, Oikawa K, Kato K and Shimizu M (2002), Ultra wideband hybrid tellurite/silica Fiber Raman amplifier,*IEEE International Conference of Optical Fiber Communication*, 47(6), 388-390.
- [32] Zhu Y, Fludger C.R.S, Lee W.S, Schilhabel P. Lobb. T. and Hadjifotiou A (2002), Experimental comparison of all-Raman and Raman/EDFA hybrid amplifications using 40 Gbit/s-based transmissions over 400 km TW-RS fiber,*IEEE Electronics Letter*, 38(16), 893-895.
- [33] Bolshtyansky J. D. M. and Wysacki P, Flat, Adjustable Hybrid Optical Amplifier for 1610 nm-1640 nm band,*Optical Fiber Communication Conference and Exhibit*, 2002, vol.33, no. 2, pp. 213-215.
- [34] Zimmerman D. R. and Spiekman L. H (2004), Amplifiers for the masses: EDFA, EDWA, and SOA amplifiers for metro and access applications,*Journal of Lightwave Technology*,22(1), 66-70.
- [35] Lee J. H, Chang Y. M, Han Y. G, Kim S. H, Chung H and Lee S. B (2005), Dispersion-Compensating Raman/EDFA Hybrid Amplifier Recycling Residual Raman Pump for Efficiency Enhancement,*IEEE Photonics Technology Letters*, 17(1),43-45.
- [36] Yoo S.J.B (1996), Wavelength conversion technologies for WDM network applications, *Journal of Lightwave Technology*, 14, 955–966.
- [37] Karfaa Yasin M, Ismail M (2007), Effects of Four-wave Mixing Crosstalk in WDM Networks on the Transmitted Optical Frequencies and Wavelengths of Channels for Various Fiber Types, *Asia pacific conference on applied electromagnetic proceedings*, December 2007.

- [38] Sugumaran S, Aggarwal Manu, Arulmozhivarman P (2014), Analysis of FWM power and efficiency in DWDM systems based on chromatic dispersion and channel spacing, *International Journal of Advances in Engineering Research*, 7,49-60.
- [39] Kaler R. S, Sheetal Anu, Sharma Ajay K (2010), Impact of Optical Modulation Formats on SPM-limited Fiber Transmission in 10 and 40 Gb/s Optimum Dispersion-managed Lightwave Systems, *International Journal for Light and Electron Optic*, 121(3), pp. 246-252.
- [40] Rasheed I, Abdullah M, Mehmood Shahid (2012). Analyzing the Non-linear Effects at various Power Levels and Channel Counts on the Performance of DWDM based Optical Fiber Communication System, *IEEE journal of quantum electronics*, pp 7-12.
- [41] Miyamoto Yutaka, Kataoka Tomoyoshi, Yonenaga Kazushige, Tomizawa Masahito, Hirano Akira, Kuwahara Shoichiro and Tada Yasuhiko (December 2002), WDM Fields Trials of 43-Gb/s Channel Transport System for Optical Transport Network, *IEEE Journal of Lightwave Technology*, 20(12), 2115-2128.
- [42] Lin W, Wolff R. S and Mumei B (2008), Decreasing EDFA transients by power shaping, *Optical Switching and Networking*, 5(4), 188-195.
- [43] Tsuritani Takehiro, Agata Akira, Morita Itsuro, Edagawa Noboru and Akiba Shigeyuki (April 2004), Ultra-Long Haul 40-Gbit/s-Based DWDM Transmission Using Optically Prefiltered CS-RZ Signals, *IEEE Journal of Selected Topics in Quantum Electronics*, 10(2), 403-401.
- [44] Hwang B, Tonguz O.K (1998), A generalized suboptimum unequally spaced channel allocation technique. Part I. In IM/DD WDM systems, *IEEE Commun.* 8(46), 1027-1037.

- [45] SongShuxian, Allen Christopher T, Demarest Kenneth R (1999), Intensity-Dependent Phase-Matching Effects on Four-Wave Mixing in Optical Fibers, *Journal of Lightwave Technology*, 17(11).
- [46] N.A.D. Huri, A. Hamzah, H. Arof, H. Ahmad and S.W. Harun, Hybrid flat gain C-band optical amplifier with Zr-based erbium-doped fiber and semiconductor optical amplifier, *Laser Physics*, 21(1), pp. 202-204, 2011.
- [47] Monika, Wason Amit, Kaler R.S (2013), Investigation of four wave mixing effect with different number of input channels at various channel spacing, *International Journal for Light and Electron Optics*, 124, 4227–4230.
- [48] Puvvada K.C. and Datta D (2010), Gain dynamics of EDFA chains in wavelength-routed optical networks, *Optical Switching and Networking*, 7(4), 165-172.
- [49] Kaler R. S (2011), Effect of channel adding/dropping on EDFA transients, *Optik - International Journal for Light and Electron Optics*, 122(5), 444-450.
- [50] Malekmohammsdi Amit, Malek Mohamed Arshad (2012), Limitation in the intrinsic method of EDFA gain optimization for 32x40 Gbit/s WDM systems, Elsevier, *Journal of Optical Technology*, 123(5), 2095-2097.
- [51] Singh S. P, Sharma A. K. and Singh N (2012), Crosstalk reduction in WDM systems using hybrid amplification technique, *Optics Communications*, 285(19), 3931-3934.
- [52] Singh S, Kaler R.S (2013), Hybrid Optical Amplifiers for 64x10 Gbps Dense Wavelength Division Multiplexed System, Elsevier, *Journal of Optical technology*, 124(17), 1311-1313.
- [53] Rajora C.S, Dhingra A (2015), Evaluation of 160*10 Gbps Single & Hybrid Optical Amplifiers at 0.1 mw using EDFA-RAMAN-SOA, *IOSR Journal of Electronics and Communication Engineering (IOSR-JECE)*, 10(3), 38-44.

- [54] Singh S, Kaler R.S (2014), Optimizing the net gain of a Raman-EDFA hybrid optical amplifier using a Genetic Algorithm, *Journal of the optical Society of Korea* ,18 (5), 442-448.
- [55] Singh S and Kaler R.S (2015), Performance Optimization of EDFA-Raman Hybrid Optical Amplifier using genetic algorithm, *Optics & Laser Technology*, 68(3), 89-95.
- [56] Jain Prince, Vashist Kadam and Gupta Neena (2014), Comparison Study of Hybrid Optical Amplifier, *International Journal of Scientific Research Engineering & Technology (IJSRET)*, 3(9), 113-116.
- [57] LiawShien-kuei, Yu1Yi-lin and Liuren-young (2014), Hybrid optical amplifiers: design and investigation, [12th IEEE international conference on solid state and integrated circuit technology 2014], vol. 31, no.17, pp. 1-4.
- [58] Rocha A. M and Nogueira R.N (2014), Flexible single pump hybrid fiber amplifier for the S+C bands, *Optics Communication*, 320(3), 105-108.
- [59] SinghS. and Kaler R. S (2014) ,Power transient and its control in Raman-erbium doped fiber amplifier hybrid optical amplifier subject to multi-channel bursty traffic, Elsevier, *Journal of Optical Technology*,81(10), 590-593.
- [60] Sekhon D.S, Jyotsana, Malhotra J (2015), Investigation of 40 Gbps DWDM Optical System by using Hybrid Optical Amplifier with Different Modulation Formats,*International Journal of Signal Processing, Image Processing and Pattern Recognition*, 8(5), 43-48.
- [61] Padwal1SoniyaN. and ChattopaddhyayManisha (2013), Performance Analysis of Hybrid Optical Amplifier in C and L Band over EDFA and RFA,*International Journal of Advanced Research in Electronics and Communication Engineering (IJARECE)*,2(1) ,4511-4514.

- [62] Karesek M, Menif M, Bellemare A (2001), Design of Wideband Hybrid Amplifiers for Local Area Networks, *IEEE Proc. Optoelectronic*, 148(3), 150-155.
- [63] Singh S, Kaler R. S (2013), Flat-Gain L-Band Raman-EDFA Hybrid Optical Amplifier for Dense Wavelength Division Multiplexed System, *IEEE Photonics Technology Letters*, 25(3).
- [64] Hashimoto Mamoru (2001), A New Method for Low Noise Automatic Gain Control of EDFAs for WDM Systems in Metropolitan Networks, [*IEEE Proc. 27th Eur. Conference on Optical Communication (ECOC'01 - Amsterdam)*], 3(5), 174-175.
- [65] Oliveira Juliano R. F (2013), Hybrid Distributed Raman/EDFA Amplifier with Hybrid Automatic Gain Control for Reconfigurable WDM Optical Networks, *Journal of Microwaves, Optoelectronics and Electromagnetic Applications*, 12(2), 41-44.
- [66] Oliveira J.C.R.F (2004), All-Optical Gain Controlled EDFA: Design and System Impact, *Telecommunication and networking- ICT, LNCS*, 3124, 727-734.