

PERFORMANCE OPTIMIZATION OF RSOA BASED HIGH SPEED BACKHAUL XG-PON HYBRID (DWDM- PON/ FSO) NETWORK

*A Dissertation Submitted in Partial Fulfillment of the Requirement for the Award of the
Degree of*

MASTER OF ENGINEERING

IN

ELECTRONICS AND COMMUNICATION

Submitted By

ASHIMA

801561006

Under Supervision of

Dr. R.S. Kaler

Sr. Professor, ECED

Thapar University, Patiala



ELECTRONICS AND COMMUNICATION ENGINEERING DEPARTMENT

THAPAR UNIVERSITY, PATIALA, PUNJAB

JULY, 2017

DECLARATION

I, Ashima, hereby declare that the dissertation entitled "**Performance Optimization of RSOA based High Speed Backhaul XG-PON Hybrid (DWDM-PON/ FSO) Network**" is an authentic record of my study carried out towards the partial fulfillment as requirement for the award of degree of Master of Engineering in Electronics and Communication at Thapar University, Patiala, under the supervision of **Dr. R.S. Kaler**, Sr. Professor, Electronics and Communication Engineering Department. The matter presented in this dissertation has not been submitted to any other University/Institute for the award of any other degree.

Date 18.09.2017

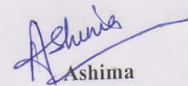
Ashima

Roll No. 801561006

It is certified that the above statement made by the candidate is correct to the best of my knowledge and belief.

Date: 18.09.2017

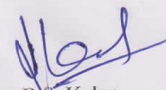
Dr. R.S. Kaler
Sr. Professor
ECED, TU, Patiala

ACKNOWLEDGEMENT

With deep sense of gratitude I express my sincere thanks to my esteemed and worthy supervisor, **Dr. R.S. Kaler**, Sr. Professor, Department of Electronics and Communication Engineering, Thapar University, Patiala for his valuable guidance in carrying out work under his effective supervision, encouragement, enlightenment and cooperation. Most of the novel ideas and solutions found in this dissertation are the result of our numerous stimulating discussions.

I shall be failing in my duties if I do not express my deep sense of gratitude towards **Dr. Alpana Aggarwal**, Professor and Head of the Department of Electronics and Communication Engineering, Thapar University, Patiala who has been a constant source of inspiration for me throughout this work, and for the providing us with adequate infrastructure in carrying the work.

I am also thankful to **Dr. Hem Dutt Joshi**, Assistant Professor and P.G. Coordinator, Electronics and Communication Engineering Department, for the motivation and inspiration that triggered me for this work.

I am greatly indebted to all my friends who constantly encouraged me and also would like to thank the entire faculty and staff members of Electronics and Communication Engineering Department for their unyielding encouragement.

At last but not the least my gratitude towards my parents, who always supported me in doing the things my way and whose everlasting desires, selfless sacrifice, encouragement, affectionate blessings and help made it possible for me to complete my degree.

Place: TU, Patiala

Date:

Ashima

Roll No. 801561006

ABSTRACT

In today's growing world there is an increasing demand for high speed connections for services like television (IPTV) and video on demand (VoD) over Internet together with high speed Internet access (HSI), to which the best solution is Fiber based access networks. Fiber to the Home (FTTH) is probably the most suitable option for a long reach network with high bandwidth demand. Passive Optical Networks (PON) use components that are high in reliability, have low cost and passive functionality. It is a shared network that uses multiplexing to send the data of multiple users through Optical Line Terminal (OLT) to different Optical Network Units (ONUs). Each ONU reads the contents of only those packets that are addressed for it. PON has evolved through different variants in the past few decades however, Gigabit passive optical network (GPON) is receiving great acceptance throughout the world.

Although fiber optical networks have low capital expenditure in comparison to other technologies, its deployment is still considered to be a tedious and high cost act in certain areas like railway lines, buildings, disaster stricken areas etc. For such situations, a hybrid access network consisting of both wired and wireless links is required. Free Space Optics (FSO) has evolved as a compromise to cabling. In comparison to traditional radio link this optical wireless link offers greater bandwidth and its operation in license free spectrum which is important reduction in cost. For multi channel transmission Dense Wavelength Division Multiplexing (DWDM) is a promising technique that allows multiple users to transmit data simultaneously through a single fiber via different wavelengths.

Thus, this Thesis work presents the results derived from the performance optimization set-up of DWDM based next-generation passive optical network (XG-PON) network that are the next generation broadband access networks. It is a hybrid 8 user network as few ONU's are communicated via FSO which is preferred last mile solution, with demonstrated downstream data rate of 40Gbps and upstream data rate of 10 Gb/s. Reflective Semiconductor Optical Amplifier (RSOA) has been made as a cost effective choice for upstream data transmission which has a fast gain recovery governed by phonon- carrier interactions and carrier-carrier scattering, thus making it operate at data rates ≥ 10 Gb/s. Impacts of various design parameters and impairments have been exploited to result in an optimized performance.

The different parameters targeted for optimization were modulation formats both for upstream and downstream, data rates, total network length, filter type and dispersion compensation. For a cost effective system RSOA was used, performance of system by varying I_{mod} current, pumping current and extinction ratio was also monitored. The simulations gave us encouraging results under certain condition which have been discussed in this thesis.

TABLE OF CONTENTS

<i>Declaration</i>	<i>ii</i>
<i>Acknowledgement</i>	<i>iii</i>
<i>Abstract</i>	<i>iv</i>
<i>Table of Contents</i>	<i>vi</i>
<i>List of Tables</i>	<i>viii</i>
<i>List of Figures</i>	<i>ix</i>
<i>List of Abbreviations</i>	<i>x</i>
Chapter 1 Introduction	1- 10
1.1 Background.....	1
1.2 Passive Optic Networks.....	2
1.2.1 PON Architecture.....	3
1.2.2 Types of PON.....	4
1.2.2.1 TDM-PON	4
1.2.2.2 WDM PON.....	5
1.2.2.3 OFDM PON	6
1.2.3 Applications of PON.....	7
1.3 Free Space Optics.....	8
1.4 Reflective Semiconductor Optical Amplifier.....	9
1.4.1 Working of RSOA.....	10
Chapter 2 Literature Review	11-19
2.1 Literature Survey.....	11
2.2 Problem Formulation.....	17
2.3 Objectives of Proposed Research.....	17
2.4 Methodology / Planning of work	18
2.5 Layout of Thesis.....	18
Chapter 3 Performance Metrics	20-24
3.1 Introduction.....	20
3.2 Bit Error Rate.....	20
3.3 Eye Diagram Analyser	22
Chapter 4 Simulation Model for Hybrid Network	25-30
4.1 Introduction.....	25

4.2	System Description.....	25
4.2.1	Optical Transmitter	27
4.2.1.1	Transmitter at OLT side.....	27
4.2.1.2	Transmitter at ONU side	28
4.2.1.3	Mach-Zehnder Modulator.....	29
4.2.2	FSO Channel.....	29
Chapter 5 Results and Discussion.....		31-39
Chapter 6 Summary of Results and Future Scope.....		40-42
6.1	Introduction	40
6.2	Summary of Results.....	40
6.3	Future Scope.....	41
References.....		43-47
List of Publications.....		48

LIST OF TABLES

Sr. No	Table details	Page No.
Table 2.1	Literature Review.....	11
Table 4.1	System Description.....	26
Table 5.1	BER and Eye diagram of channel 1 and 8 for downstream.....	31
Table 5.2	BER and Eye diagram of channel 1 and 8 for upstream.....	32
Table 5.3	BER for different modulations formats at different wavelengths for (8x40)320 Gb/s at 60 km in downstream transmission.....	32
Table 5.4	BER for different modulations formats at different wavelengths for (8x10) 80 GB/s at 60 km in upstream transmission.....	33
Table 5.5	BER for OQPSK modulation at different data rates in downstream transmission	35
Table 5.6	BER at different data rates for CRZ modulation format at uplink transmission.....	35
Table 5.7	BER at 40 Gb/s for different total network length	36
Table 5.8	BER value for different filter at 40 Gb/s /60 kms downstream.....	36
Table 5.9	BER at 40 GB/s data rate using Dispersion Compensation.....	37
Table 5.10	BER at different RSOA pump current for data rate of 10 Gb/s.....	38
Table 5.11	BER at 10 Gb/s upstream for different electrical modulation current.....	38
Table 5.12	BER at optimized RSOA pump current and electrical modulation current for various ER.....	39

LIST OF FIGURES

Sr. No	Figure Details	Page No.
Figure 1.1	Schematic Diagram of Simple Doped Fiber Amplifier.....	2
Figure 1.2	PON Architecture.....	6
Figure 1.3	Data rate specifications of various PON standards.....	6
Figure 1.4	WDM-PON Architecture.....	6
Figure 1.5	OFDM-PON Architecture.....	7
Figure 1.6	FSO based PON Network.....	9
Figure 1.7	Working of RSOA.....	10
Figure 3.1	Eye Diagram Analyzer.....	23
Figure 4.1	Block Diagram of simulation setup of bidirectional DWDM-PON for 8 channels	25
Figure 4.2	Simulation setup of bidirectional DWDM-PON for 8 channels in OptiSystem.....	26
Figure 4.3	8- Channel DWDM transmitter.....	27
Figure 4.4	OLT components for single channel.....	28
Figure 4.5	RSOA Subsystem.....	29
Figure 4.6	Mach- Zehnder Modulator.....	29
Figure 5.1	CRZ Format.....	33
Figure 5.2	RZ Format.....	34
Figure 5.3	NRZ Format.....	34

LIST OF ABBREVIATIONS

VoD:	Video on Demand
FTTH:	Fiber to the Home
PON:	Passive Optical Networks
ONUs:	Optical Network Units
GPON:	Gigabit passive optical network
FSO:	Free Space Optics
WDM:	Wavelength Division Multiplexing
DWDM:	Dense Wavelength Division Multiplexing
XG-PON:	Next-Generation Passive Optical Network
RSOA:	Reflective Semiconductor Optical Amplifier
EDFA:	Erbium Doped Fiber Amplifier
AONs:	Active Optical Networks
ODN:	Optical Distribution Network
TDM:	Time Division Multiplexing
BPON:	Broadband Passive Optical Network
EPON:	Ethernet Passive Optical Network
QoS:	Quality of Service
GEM:	GPON Encapsulation Method
P2P:	Point to Point
OFDM:	Orthogonal Frequency Division Multiplexing
CATV:	Community Antenna Television
POTS:	Plain Old Telephone Service
LOS:	Line Of Site

SOA:	Semiconductor Optical Amplifier
RSOA:	Reflective Semiconductor Optical Amplifier
DQPSK:	Differential Quadrature Phase Shift Keying
ASE:	Amplified Spontaneous Emission
NRZ:	Non Return-to-Zero
RZ:	Return-to- Zero
CRZ:	Chirped Return-to-Zero
OQPSK:	Orthogonal Quadrature Phase Shift Keying
ITU:	International Telecommunication Union
BER:	Bit Error Rate
MZI:	Mach-Zehnder Interferometer
CD:	Chromatic Dispersion
EML:	Electro-absorption Modulated Laser

CHAPTER 1

INTRODUCTION

1.1 BACKGROUND

In the given scenario, with advances in communication systems high data rate and large bandwidth's seem to be never ending demands. For housed customers the requirement is high speed networks for voice and other upcoming services, entrepreneurs need fastest broadband connections as internet is their backbone. In this era of cloud computing, big data, internet banking, IPTV we are all internet savvy's who require high speeds and usage security at lower costs. From copper cables about a century ago to fiber optic cables, we have delivered our best capabilities to send large amounts of information at good data rates to long haul distances [1].

Optical Communication Technology allows us to have large bandwidths. Owing to the progress in optical networks, long distance transmission with high capacities is now achievable. Since there is degradation as the distance increases optical networks require efficient modulators, wavelength convertors, optical amplifiers, multiplexers, splitters and arithmetic processing. PONs provide us with an efficient solution for future networks, as they are energy efficient and have huge bandwidth [2]. A fiber optical communication system generally consists of a transmitter, optical cables, amplifiers and receiver. Lasers are preferred transmitters over LED's because they are coherent, give high output power and reduce chromatic dispersion. External modulators like Mach Zehnder interferometer are used to increase the link distance, reduce the linewidth and laser chirp. Single mode fibers are preferred over multimode fibers which have larger cores for long distances. An optical receiver is necessarily a photodetector which uses photoelectric effect to convert light into electrical signal. To combat the transmission losses like attenuation and distortion opto-electronic repeaters were introduced however, due to their high cost expenditure involving conversion of signal in optical to electrical and then again optical they have been replaced by optical amplifiers. Optical amplifiers amplify the signal directly without undergoing the hassle of conversion in different domains. It is made by simply doping a fiber with rare earth mineral like erbium resulting in Erbium Doped Fiber Amplifier (EDFA) which needs pumping by a shorter wavelength of typically 980nm. Other types of amplifiers are semiconductor optical amplifiers or Raman amplifiers. The amplifiers can be used as power boosters for transmitters, in-line amplifiers, and optical pre-amplifiers.

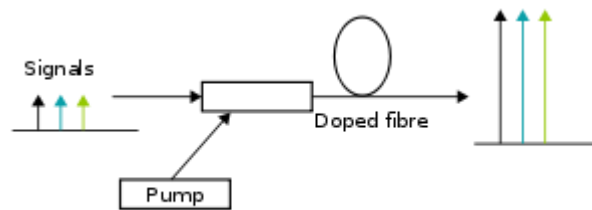

Figure 1.1 Schematic diagram of simple doped fiber amplifier

1.2 PASSIVE OPTICAL NETWORKS

The new era telecom services are offering IPTV, social networking, video conferencing, gaming, HDTV, video on demand to an ever growing no. of users and the only way to meet the needs of these progressive generations of telecommunications is through optical fiber based access networks [3]. Copper based access networks have distance and bandwidth limitation and will fall short of capacity in near future. The optical fiber based access methods are getting more and more attention as they offer the advantageous solution in delivering different services to the customer premises. Optical solutions can provide the required channel capacity to meet the demands of future [4].

In the past few decades a multidirectional and an exhaustive research in the field of optical access networks has resulted in innovative ranges such as point-to-point (P2P) networks, active optical networks (AONs) and passive optical networks (PONs). PONs have been traced among the widespread researchers to be to be the most effective networks as compared to its other classes of fiber access, owing to their flexibility, scalability and their being more future-proof [5]. Also they offer the profitable advantage of reduction in operational expenditures (opex) and capital expenditures (capex) [6]. The motive of PONs is to be able to provide a single uniform architecture for the multiple services in consonance with varied rates of bit and modulation format in the Next Generation Access Networks (NGAN) as this results in keeping the energy consumption and cost expenditures suitably low. No wonder PONs turn out to be the most suitable networks to meet the requirements of service providers. [7]. Optical networking is well established in long-haul and backbone networks. It is quickly becoming the chosen technology in metropolitan and local area networks. PON is network based on access through optical fiber especially designed to provide virtually bandwidths of any range at the consumer end. PON is a single optic cable or fiber which is receiving an optical signal, dividing or splintering the signal and sharing it with the individual users. It is termed passive as it does not entail any active access elements within its network except those at its central source point. A PON is an effective tool in the hands of the service providers as it enables them to distribute a near perfect equilibrium of the

trio- video, voice and data. Fiber to the home (FTTH) is on a fast track and thereby is all set to establish PON [8]. IPTV is an important factor playing its role as an added attraction and incentive for PON.

1.2.1 PON Architecture

PON networks consists of three main parts

- Optical Line Terminal (OLT): The OLT is suitably located at the service provider's end. The purpose of OLT is to bring an interface between (PON) passive optic network and the main support network sometimes referred to as backbone network. It has two functions :
 - i. Conversion of the signals widely put in use service provider to the frequency and framing being used by the PON system.
 - ii. Matching the type and extent of multiplexing that occurs between various conversion devices on the optical network terminals (ONTs) located at the customers' ends.
- Optical Network Unit (ONU): The ONU is user side equipment. It does the task of providing service interface to end users. ONU in unison OLT provides data port , phone port and bandwidths upto 200Mbps in full duplex mode allowing customers to use services such as VoIP, HDTV etc.. Optical network unit is economic and efficient equipment and plays a crucial role in the FTTx fiber network.
- Optical Distribution Network (ODN): The ODN in PON connects the OLT at the central office and ONUs near user homes by using optical fibers, fiber optic connectors, passive optical splitters and auxiliary components, thus forming a requisite path for transmitting PON data which directly affects the performance, reliability, and scalability of the system. The ODN usually is usually classified as a tree structure with the OLT as the root of the tree and ONUs as leaves of the tree.

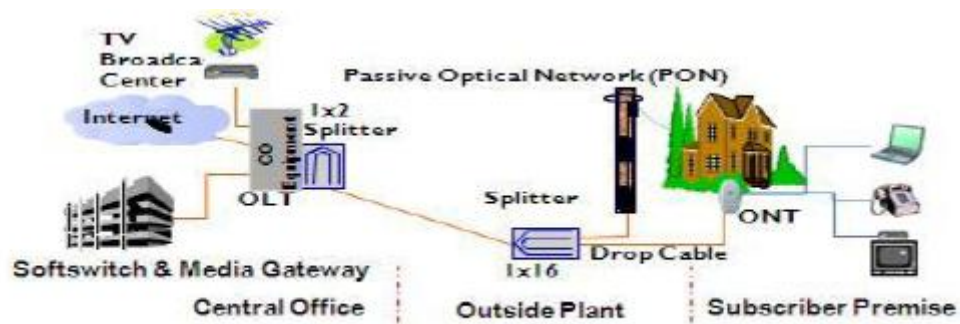

Figure 1.2 PON Architecture [9]

1.2.2 Types of PON

Based on the data multiplexing scheme there are three main types of PONs. Presently the extensively deployed PON technology is time division multiplexing (TDM) PON, where data from/to multiple ONUs is time multiplexed onto the wavelength in both upstream and downstream direction. Other two types are Wavelength division multiplexing (WDM) PON and orthogonal frequency division multiplexing (OFDM) PON. WDM PON uses users using multiple wavelengths to transmit data to/from ONUs, while OFDM PON makes use of orthogonal subcarriers to transmit traffic to/from ONUs. WDM and OFDM PON allows data rate higher than 40 Gb/s and even Tb/s. While TDM PON is being used extensively future of PONs lies in WDM and OFDM PON structures.

1.2.2.1 TDM-PON

TDM-PON systems, are presently installed PON systems which include ATM PON (APON), Broadband PON (BPON), Ethernet PON (EPON), Gigabit PON (GPON), 10G EPON, and Next-generation PON (NG-PON) providing varying data rates.

- **APON/BPON (ITU-T G.983)** : APON or ATM PON, is the initial PON specifications laid by the FSAN committee. APON uses Asynchronous Transfer Mode as signaling protocol in layer 2. For APON, downstream transmission is an unbroken ATM stream at a rate of 155.52 Mb/s or 622.08 Mb/s while the upstream transmission takes place as bursts of ATM cells. As per ITU-T G.983 series broadband PON (BPON), is an enhancement of the APON system. BPON has the capability of offering abundant of broadband services like ATM, Ethernet access, and video distribution. [10, 11].

- **GPON (ITU-T G.984)** GPON encapsulation method (GEM) is used to attain proficient casing of user data, with frame segmentation to provide higher quality of service (QoS) for delay-sensitive traffic involving voice and video applications. It uses three layer-2 networks: proprietary encapsulation for video, ATM for voice and Ethernet for data enabling GPON to support capabilities like voice, TDM, Ethernet, ATM, leased lines, and wireless extension [12].
- **NG-PON (ITU-T G.987)** XG-PON1 commonly known as Asymmetric 10G-PON, gives downstream and upstream data rate of 9.9528 Gb/s and 2.488 Gb/s respectively. This architecture enhances the downstream link capacity to 10 Gb/s. The complexity faced by the architecture in supplying 10 Gb/s data rate is to facilitate the burst mode time-division multiple access (TDMA) operated at 10 Gb/s. Limitation of accessible components and design practices result in many simple circuit techniques turning unfeasible when the rate crosses 5 Gb/s. Overcoming this limit requires dedicated hardware which increases the cost sharply. Symmetric 10G-PON, popular as XG-PON2, has data rate 10 Gb/s in both upstream and downstream direction.

	APON/BPON	GPON	XG-PON1	EPON	10G-EPON
Standard	ITU-T G.983	ITU-T G.984	ITU-T G.987	IEEE 802.3ah	IEEE 802.3av
Downstream speeds	622 Mbps	2.488 Gbps	9.9528 Gbps	1.25 Gbps	10.3125 Gbps
Upstream speeds	155 Mbps	1.244 Gbps	2.488 Gbps 9.9528 Gbps	1.25 Gbps	1.25 Gbps 10.3125 Gbps

Figure 1.3 : Data rate specifications of various PON standards [13]

1.2.2.2 WDM-PON

There are a number of advantages WDM PON Architecture has over Conventional TDM PON systems. First of all WDM PON networks categorically brings better security to the consumers as each home is susceptible to one wavelength, that remains its very own wavelength. Second WDM PON subscribe every user with one or more wavelengths, and thereby every subscriber has an access to full bandwidth corresponding to these wavelengths. Third WDM PON network allows for maximum flexibility. Considering that in this network every wavelength is effectively a P2P link, thereby it permits every link an access to different speeds and with different protocols for utmost flexibility along with self improving upgrades. Also,

WDM requires simpler MAC layer control because of direct connection between OLT and ONU.

In addition to all these vantage points, WDM PON has a very strong contention in its favour. It is found to be cost enhancing owing to its wavelength specific features of WDM components. One way to deal with this is using tunable lasers so as to tune each ONU to a desired wavelength. This is however an expensive way to deal with the problem as the tunable lasers are costly. Another way is to provide every subscriber wavelength-specific fixed tuned laser. It is however tedious to use individual wavelength specified sources in the OLT of WDM PON as it requires a big number of optical sources with different wavelengths. These cost-prohibitive devices, however constitute a major hurdle in early design of WDM PON systems.

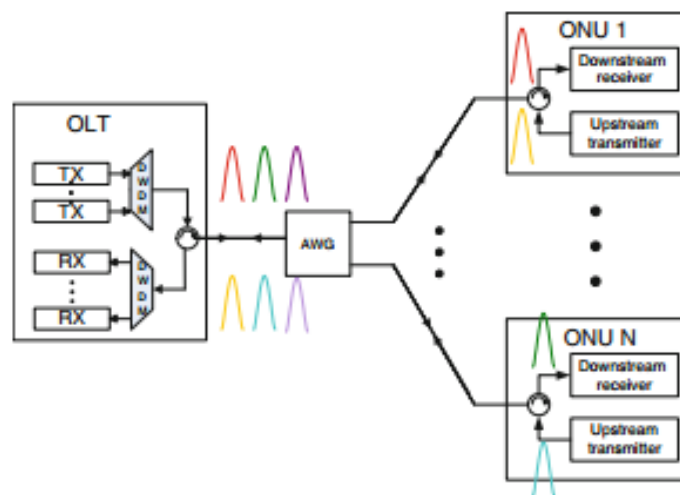

Figure 1.4 : WDM-PON Architecture [13]

1.2.2.3 OFDM-PON

Orthogonal frequency division multiplexing (OFDM) PON makes use of OFDM as the modulation scheme and utilizes its superior transmission competence to improve the bandwidth provision of optical access networks. OFDM uses . A huge number of closely-spaced orthogonal subcarriers are used by OFDM to carry data traffic. Modulation of each subcarrier is carried out by a conventional modulation scheme at a low symbol rate, thereby achieving a compatibility in the sum of the rates provided by all subcarriers to those of conventional single-carrier modulation schemes in the same bandwidth. The duration of each symbol is relatively large as each subcarrier

carries a low data rate. The inter-symbol interference can thereby be effectively reduced in a wireless multipath channel. In optical communications polarization mode dispersion as well as the chromatic dispersion has similar effects as those of multipath. Therefore, implementing the OFDM modulation scheme in the optical access network can impressively enhance the network provisioning data rate and increase the network reach.

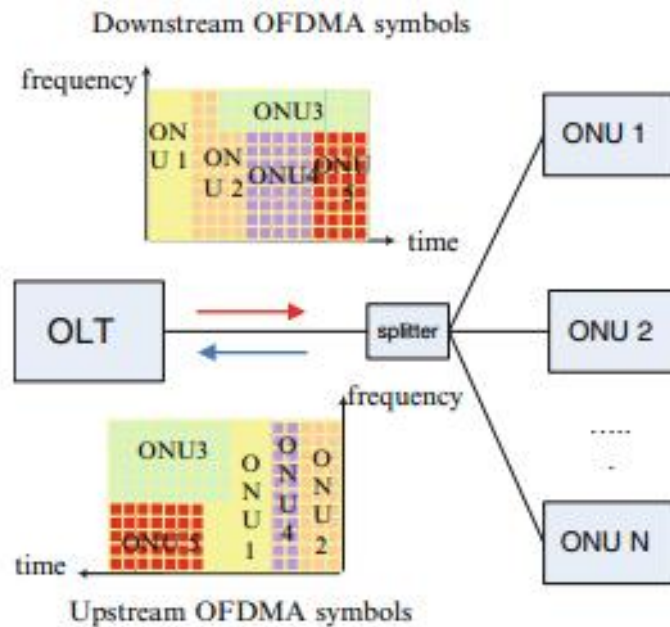

Figure 1.5: OFDM-PON Architecture [13]

1.2.3 Applications of PON

PONs are being extensively used in North America for triple play networks in which voice, video and data are provided in single subscription access. RF overlay using WDM offers community antenna television (CATV) type video service with broadband internet, home gateways to separate IP video and provide Plain Old Telephone Service (POTS) conversion. Entire network is based on IP and Ethernet [14]. FTTH in Japan is the internet broadband application of IP/Ethernet and it is still dominant. The broadband access of 100 Mbit/s by ONU in indoors is the best economical service. The system is like simple extension of ADSL [15].

PON systems are employed on the backhaul of residential services through the FTTC-VDSL i.e. fiber to the curb, FTTP-G-fast (upcoming) i. e. fiber to the distribution point, FTTB-VDSL i. e. fiber to the building, FTTH-G/EPON

i.e. fiber to the home. PON systems are also used for the backhaul of business/enterprise services by FTTH i.e. fiber to the office, and backhaul of Mobile Services by fiber to the cell tower.

1.3 FREE SPACE OPTICS

Currently, all optic networks used for backhaul are based on three media- copper, wireless (radio, free space optics) and optical fiber. Out of three the optical fiber links are capable of implementing high data rates, are also more reliable, and causes low signal loss. Therefore these turn out to be the most suitable answer to address the needs of next-generation backhaul networks. In some cases, however, like after the disasters, in tough installation places, or in higher mobility applications, communication through fiber is not feasible due to exorbitant setting up costs and the liveness limitation [16-18]. Free Space Optics prevalently known as optical wireless is an optical technology in which light travels through free space without any guided medium from transmitter to a distant receiver. The increasing interest for this technology is based on the potential of this upcoming technology. Its use is being encouraged for both short (few metres) and long ranges (to few kms) like ground to satellite links [19]. Acting just like a radio link it offers advantage of greater bandwidth, experimental connections have even displayed results with Tb/s capability making FSO a preferable choice [20]. Another capex reducing feature of FSO is its spectrum that lies around 200 THz being license free. FSO offers information security as it is a line of sight (LOS) based technology which does not allow interception, as interception leads to interruption of the communication. It is vital to ensure the alignment of the narrow laser beam for the steady performance of the system [21]. FSO suffers from certain disadvantages too in the form of dependence on atmospheric and environmental conditions. Atmospheric conditions like fog, rain, dust, snow can increase the attenuation alarmingly because such conditions make it impossible to predict the molecular absorption and scattering. Usually systems require O-E-O (optical-electrical-optical) conversions which result in reduction of the bandwidth and also of the optical power due to the coupling loss. There is also a remarkable increase in the power consumption and the set-up costs. To avoid these losses the focus should be on all optical systems that couples the light from optical fiber directly to the wireless channel, and thereby avoiding the abruptness of entering in the electrical domain [22].

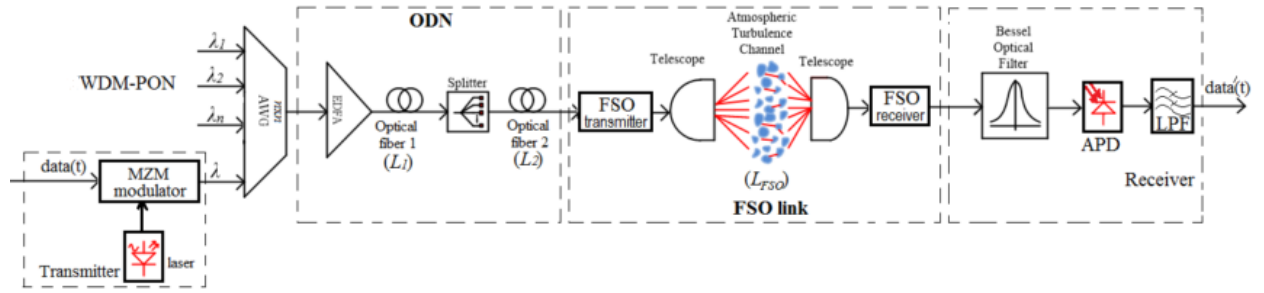

Figure 1.6: FSO based PON network [23]

Hence, the combining of wireless and optical technologies result in proficient, flexible, cost effective and energy conserving backhaul network [24-26]. FSO is conveniently being considered as a very lucrative first step in the arena of access solution courtesy higher flexibility, less expenditure and easy installation and re-installation [27-28].

1.4 REFLECTIVE SEMICONDUCTOR OPTICAL AMPLIFIER (RSOA)

A Semiconductor Optical Amplifier (SOA), as well as a Reflective SOA (RSOA) are highly nonlinear devices which are used for signal amplification, signal modulation, and optical signal processing applications such as wavelength conversion, switching and optical time domain De-multiplexing. The RSOA has two input ports and one output port. The first input accepts optical signals, which can consist of one or more optical channels. The second input accepts an optional electrical modulation current. Finally, the output port generates the resulting output optical signal. A RSOA uses a central light source and hence offers us the benefit of reducing deployment and maintaining costs linked closely with the fixed wavelength light sources required at the ONUs installed at the customers' premises. This semiconductor optical-electronic device works by imposing data on the incoming light. Hence, the wavelength explicit light sources can be all positioned at the centre, providing service gives the central management of failure-prone light sources. RSOA, also amplifies the arriving light along with signal modulation. It helps in precluding the requirement of expensive optical amplifiers at the customers' place and also helps to attain adequate power requirement for the upstream transmission. Somehow, the modulation bandwidth of the RSOA is characteristically restricted to few GHz because of the carrier life span in the active layer, which confines the upstream data rate to 1.25 Gb/s [29-30]. In recent times, there have been quite a few attempts to drive these low-bandwidth devices at 10-Gb/s and further, using advanced modulation formats [31]–[34], post detection electrical signal processing [35]–[37], and offset optical filtering along with electrical equalization [38]. Of late, 10-Gb/s function of a transistor-outlook (TO)-can-packaged RSOA using an optical delay interferometer (DI) has been established [39]. This straightforward and passive device acts as a two-tap optical

equalizer and greatly improves the system bandwidth and that too without any support of electrical signal processing done post detection. A fraction of the downstream signal is detected at the ONU but another fraction can be again used for the upstream transmission. This process of reuse of wavelength considerably lessens the number of light sources to half for full-duplex transmission and also relieves the wavelength necessities of the optical components in the system.

1.4.1 Working of RSOA

The working of RSOA is a simple process in which an electric current is passed through the device that stimulates the electron in active region. While travelling in the active region these photons lose some of their extra energy in form of photons whose wavelength match with wavelength of the initial one. The efficiency of this design is based on the capability of the RSOA to re-modulate the received downstream signal with the new upstream.

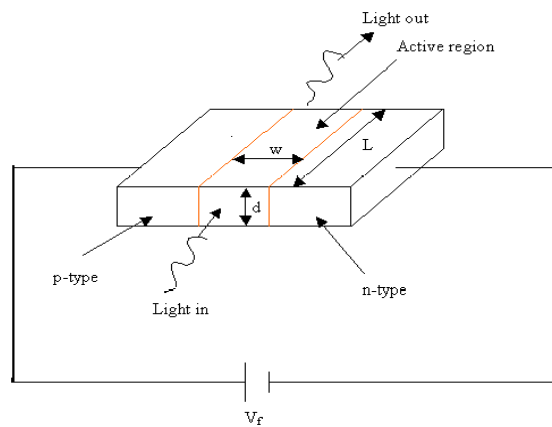

Figure 1.7: Working of RSOA

CHAPTER 2

LITERATURE REVIEW

2.1 LITERATURE SURVEY

A comprehensive review of the work in the field of Optical communication systems reported by various researchers is presented below in tabular form in table 2.1 is briefly described thereafter:

Table 2.1 Literature review

S No.	Particulars	References
1	WDM-PON Networks	A. Chenika[2014], P. K. Choudhury[2015], T. B. Gibbon[2011], K. P. Kaur[2014], Randeep Kaur[2017], Z. Al-Qazwini[2013], M. Al-Quzwini[2014], Veen D[2015], T. Su[2013], B.Kaur[2013]
2	FSO technology	T. V. Nguyen[2016], S. Di Bartolo[2014], Parkash S[2016]
3	RSOA	S. H. Cho[2012], M. Fujiwara[2009], L. Tawade[2015], E. Udvary[2016], Z. Al-Qazwini[2012], Q. Hu[2015], T. Su[2013], B.Kaur[2014]

Abdelfettah Chenikaa et al. [40] in their work have compared four channel high speed WDM-PON systems for two different modulation formats that are NRZ-ASK/ASK and NRZ-DQPSK/ASK for a distance of 30 km at a data rate 160/40 Gb/s. For the uplink transmission they have re-modulated the data on downlink optical carrier avoiding the usage of a new laser at the client side and also using the same wavelength in both directions allowed having a greater number of user channels. Effects of the Rayleigh and Brillouin backscattering have been considered. The architecture with DQPSK modulation presented a gain of 0.5 dB and was highly favorable for next generation optical access networks.

Seung-Hyun Cho *et al.* [41] proposed using a uni-mode laser with optical feedback as a seeding source to remove the reflected induced crosstalk in a WDM-PON based RSOA network, by using a single mode laser with intentional optical feedback as a seeding source. By maintaining minimal power penalty required signal to crosstalk ratios were generated by changing the optical feedback ratio. The proposed system tends to enhance the upstream and downstream system performance under lower signal to crosstalk ratio.

Pallab K. Choudhury [42] analyzed and compared the performance of upstream signal when encoded via Miller and Manchester coding scheme for a RSOA based loopback WDM-PON system with centralized continuous wave seeding source. This work successfully demonstrates the improved performance of the system against Rayleigh backscattering noise on using coding scheme and hence bringing the signal to crosstalk ratio down to 15dB. Also it was reported that we can enhance system capacity by using Miller coding scheme as it requires less electrical bandwidth particularly benefiting bandwidth limited devices.

Masamichi Fujiwara *et al.* [43] estimated the loss budget of WDM single fiber loopback access networks that used an amplified spontaneous emission (ASE) light source with an optical modulator and amplifier at the ONU. They studied the back reflection lights from two sources one from the ASE and other from the ONU. A gain saturated-SOA if placed at the ONU increased the loss budget of transmission line and reduced the excessive intensity noise of ASE and beat noise from ONU, slicing the need of a pre-optical amplifier from optical receiver.

T. B. Gibbon *et al.* [44] Vertical Cavity Surface Emitting Lasers (VCSELs) otherwise ideal source for PONs were severely limited by wavelength chirp and chromatic dispersion for data rates more than 10 Gb/s. This shortcoming could be adequately dealt with by using an offset between the transmission wavelength and the central wavelength of an AWG passband which resulted in chirp reduction. The system experimentally demonstrated transmission at 10 Gb/s VCSEL over 23.6 km of single mode fiber with a dispersion penalty of 2.9 dB. The simulated results showed that the off-center wavelength filtering could extend the 10 Gb/s network reach from 11.7 km to 25.8 km at a 4 dB dispersion penalty. This allowed for a simple and cost effective dispersion mitigation technique in next generation VCSEL-based optical access networks.

K. P. Kaur *et al.* [45] analyzed the performance of a WDM-PON system with data rate 40 Gb/s using different receiver filters namely Bessel filter, Butterworth filter, Chebyshev filter, Integrator filter, Inverse Chebyshev filter, Elliptic filter, Gaussian filter and Rectangular

filter. Out of all these filters Bessel filter came out to be the most promising candidate for a system with 40 Gb/s (4X10 Gb/s) data rate and 100 GHz channel spacing.

R. M. Mu *et al.* [46] studied WDM systems by comparing three different modulation formats: NRZ, RZ and CRZ with single-channel data transmission rates of 10 Gb/s. CRZ was concluded to be best suited to obtain a transmission distance greater than 5000 km with reasonable power margins, CRZ modulation format was best suited. Further investigation was based on the evolution of individual CRZ pulses. Their advancement was subjugated by chromatic dispersion and is only slightly affected by the nonlinearity at optimal power levels. The Studying of trains of pulses, resulted in conclusion that amplitude jitter generated by spontaneous-signal beat noise a key characteristic of liner systems is the reason of spread in the eye diagrams. Symmetric compensation was found out to be more suitable to minimize the effects of the nonlinearity. Examination of eye diagram suggest inter channel nonlinearities because of spreading of the eye, however there is no alteration in CRZ pulse dynamics. CRZ systems have been referred to as quasi-linear as they are primarily linear with nonlinearity in designing of dispersion maps and channel spacing.

T. V. Nguyen *et al.* [23] perused a gigabit-capable flexible mobile backhaul network based on TWDM-PON and FSO technologies. In a mathematical model designed for downlink system, theoretical and comprehensive analyzing of network parameters like amplifier gain ,the maximum reach, splitting ratio, FSO link distance and the system bit rate was done for system performance. A comparison was conducted based on the performance of TWDM-PON/FSO hybrid system to that pure TWDM- PON network. The mathematical results showed that the combination of TWDM-PON and FSO could provide a flexible and large bandwidth (of the order of gigabits) capable solution for NGAs

Randeep Kaur and Nitika Soni [47] highlighted the limitations of bandwidths as a deterrent to the access in previous technologies and this being an en route to an ever-increasing demand for a more bandwidth resulting in the introduction of fiber to the premises for promoting new high speed services. Point to multipoint architecture (P2MP) has resulted in implementation of (PON) a passive optical network for better access to networks. In their paper they have not only reviewed the general architecture of PON and endeavored to establish its importance in the field of telecommunications but have also earmarked the different PON types that facilitate the evolution path to greater bandwidths. The paper compared the current and next generations of PON technologies and also highlighted the significant differences as well as conspicuous similarities in the two keeping in mind that they share the same fiber medium and physical topology. It was established that PON

systems were very much a call of the future vision as all of these systems have a similar set of requirements on the access cable facilities and differences would only be at the level of base technology and designs. An observation was made that the once exorbitant expenditure of the cables was met; any changes in technology with time could be easily introduced and absorbed in future with minimal expenditure.

L. Tawade *et al.* [48] demonstrated that WDM-PON system can be effectively implemented for 45Km. They investigated the far reaching system capable of delivering downstream 20Gbit/s data and upstream 10Gbit/s data on a single wavelength. As transmitters for downstream communication Pulse source-mode locked laser was used and for upstream data two RSOAs combined output for the 10 Gb/s transmission were used. The maximum reach of 45 Kms was extended to this WDM-PON by using the hybrid Erbium-doped fiber amplifiers at the RN with an aim to enhance the signal power. Use of Optical Equalization technique before the receiver was made so as to improve modulation bandwidth of an RSOA based colorless optical network unit and hence the downlink and uplink performance. The results exhibited that the problem of linear and non linear effects could be met and an error free transmission could be achieved for downstream and upstream channels. Furthermore it was also traced that the hybrid amplifiers were effective in simplifying the complication of bi-directional long reach WDM-PON system, and in enhancing the signal sensitivity in transmission. Hence it was established that it was possible to build up the data rate and long reach optical link concertedly in future WDM-PON access networks.

E. Udvary *et al.* [49] floated an idea for bandwidth improvement of RSOA based external intensity modulators in Next-generation access networks (NGANs). The Idea is rooted in the fact that NGANs mainly include wavelength division multiplexing (WDM) based 60GHz Radio over Fibre systems (60G-RoF) and WDM Passive Optical Networks (WDM-PONs). The SOA being the vital device in WDM based systems could be effectively utilized as external modulator for their ability to perform amplification and modulation at the same time, although the modulation speed was limited owing to the internal processes of the device. The chirping characteristics of semiconductor optical amplifier could be used for bandwidth increase through the method of optical equalization. Through simulation and experiments it was established that the limited modulation transfer function could be combined with the converted phase modulation transfer function as the Direct modulation produced optical signal modulated both in amplitude and phase. Chromatic dispersion of the optic fiber, the other problem that effects the transmission had also been addressed. The slope and chirp dependence of the modulation band was presented through simulations and measurements.

The simulation model was also stated as adequate to take into account the dispersion effect. The results obtained suggested that the methods enable the use of the RSOA as intensity modulator with improved performance along with an extended data rate.

Z. Al-Qazwini *et al.* [50] presented a model of a cost-effective, 10-Gb/s full-duplex wavelength-division-multiplexed passive optical network over 20 km single-feeder fiber using a single light source per optical network unit (ONU). They explored the use of a directly modulated laser (DML) and a reflective semiconductor optical amplifier (RSOA) for downlink and uplink, respectively. Thereby the experiment entailed a downward transmission on a DML being fed with a nonreturn-to-zero (NRZ) downstream signal which was first frequency up-converted to around 20 GHz. A part of the downstream signal was detected at the ONU after transmission over the feeder fiber, and the other part was fed to the RSOA as seed light. A signal of 10-Gb/s NRZ was then directly fed to the RSOA for upstream transmission. An optical delay interferometer was used at the upstream receiver so as to subdue the bandwidth limitation of the RSOA. The passive optical device acted as an optical equalizer and enabled the 10-Gb/s upstream signal to be adapted with a 1.3-GHz-bandwidth RSOA. The interference between the downstream and upstream signals was observed and studied along with the nonlinear frequency mixing of the downstream and upstream signals in the RSOA. It was observed that in spite of the downstream and upstream signals being allocated in separate frequency bands there was a nonlinear interference from the downstream signal into the upstream baseband signal. The nonlinear frequency mixing in the RSOA operating in the saturation condition was instrumental in this interference. It was proposed that this problem could be addressed by using an RSOA with a higher saturation power. It was hence proved through experiments that with a directly modulated semiconductor device and keeping the downstream frequency 20 GHz it was possible to have lucrative cost sensitive optic access networks.

Z. Al-Qazwini *et al.* [51] proposed using a RSOA for converting all-optical wavelength to build up a colorless optical transmitter for the purpose of upstream transmission in WDM-PON network. The proposed colorless optical transmitter consists of an electro-absorption modulated laser (EML), an optical coupler, and RSOA, and is based primarily on the fast gain recovery of the RSOA controlled by carrier-carrier scattering and phonon-carrier connections. Thus, making it extensively operate at Gb/s. Colorless transmission is obtained as EML, which is provided with two wavelength bands (pump signals and probe signals) can have any random wavelength in the pump band. The demonstrated setup shows the transmission of a 10.7-Gb/s upstream signal works over 30 nm of either the pump (EML

output) or probe (seed light) wavelength in a single-fiber loopback configuration. . Thus, the given scheme could be used as a substitute solution to reflective SOA-based transmitter to execute high-capacity WDM-PONs operating at 10 Gb/s per channel and beyond.

M. Al-Quzwini [52] established a schematic design and proposed a plan for the widespread implementation of a protected GPON FTTH access network to serve 1000 users. The proposed design entailed Class B protection, to safeguard the feeder and GPON port. And towards that purpose focus was on covering all the practical aspects and utilize the field experience. For this the basic requirements, the total number of locations, the distance and the infrastructure already available was taken into account and then a design with size of network and its requisites was charted . It was taken in account that the OSP design turn out to be best based on the physical survey of each root as the desk top design tended to be away from real causes and thereby could end up in wastage of time and capital. In order to assess the validity of the design for remote locations, the optical power budgets had to be taken into account and calculated. The results disclosed were satisfactory as the highest power loss was -23.196 dB which was well below the upper limit. An implementation chart was formulated in which summary of all the implementation steps and testing procedures were discussed. The procedure discussed in this paper could be instrumental in saving a big amount of effort, expenditure and speed up commissioned projects.

S. Di Bartolo *et al.* [53] demonstrated an experimental set-up of a PON network using FSO technology. The reported results analyzed multiple services of TV and data together through FSO link.OLT and ONU were connected via FSO in back to back configuration. FSO popularly known as optical wireless link offered the advantage of being energy free as no need of optical-electrical-optical conversion was required. They required just a system of lenses for communication. The results showed the possibility of using free space link in PON networks, point to point configurations and also for different wavelengths carrying data of different services travelling in the network. They concluded with the belief that this FSO solution for backhaul connections could be foundational in the implementation of 40 wireless networks.

Zhou *et al.* [54] simulation of an adaptive terminal dispersion compensation and demodulation scheme based on dual-feedback strategy for 40 GB/s return-to-zero differential quaternary phase shift keying (RZ-DQPSK) fiber communication receivers is proposed to achieve high reliability receiving performances. In this paper we reviewed that utilize both the balanced receiver feedback and framer error rate to achieve accurate RZ-DQPSK optical signal demodulation and adaptive dispersion compensation. Compared to traditional RZ-

DQPSK receivers, the proposed design combines the chromatic dispersion (CD) compensation and Mach-Zehnder interferometer (MZI) adjusting and automatically estimates the dispersion compensation parameters without human intervention .

Kaikai *et al.* in [55] optimized the performance of standard WDM at 40 GB/s four-channel transmission system, numerical simulations are carried out to comparing three different dispersion compensation techniques (without compensation; periodic dispersion compensation at the front end; and dispersion compensation all at the end of the system by means of highly dispersed pulses) for chromatic dispersion on a terrestrial 40 GB/s system. Both the loss and dispersion of the transmission fiber are periodically compensated, since two dispersive elements are placed at the input and the output ends of a compensation period. Further performance optimization includes how to properly match the EDFA power and length of the fiber.

2.2 PROBLEM FORMULATION

The demand for higher capacity of optical transmission system is increasing continuously. To increase the amount of data that can be transmitted at a given time we have WDM as a multiplexing technique. Dense Wavelength Division Multiplexing (DWDM) is a trifurcation of WDM systems which uses the C-Band transmission window (1530 nm-1565 nm) but with denser channel spacing. As per International Telecommunication Union (ITU) the channel spacing can range from 12.5 GHz to 100 GHz and wider in some cases [56]. WDM based standards aim at introducing high bandwidth capacity per user . A typical DWDM system would use 40 channels at 100 GHz spacing or 80 channels with 50 GHz spacing.

It has been seen from the literature that most of the work has been done on PON networks with data rate of 10 Gbps (Downlink) and 2.5 Gbps (Upstream). Moreover, there is no study of hybrid WDM-PON/FSO networks. FSO is a wireless technology in optical domain that can transmit data via free space without using any guided medium like optical fiber. FSO has established itself as a more efficient technology for places having difficulty in deployment. In our work, data rate is enhanced using modern modulation format and RSOA is used for upstream data, which is a cost effective technique and optimized for better performance. Moreover, a combination of DWDM-PON/FSO is implemented and analyzed.

2.3 OBJECTIVES OF PROPOSED RESEARCH

Keeping in view the above, the research is based on following objectives:

1. To model and simulate hybrid XG-PON (DWDM-PON/FSO) optical backhaul network.

2. To optimize the performance of the designed system by varying different modulation formats for upstream and downstream links.
3. Performance evaluation based on data rate, network length, filter type and dispersion compensation.
4. Investigation based on varying the parameters of RSOA.

2.4 METHODOLOGY/ PLANNING OF WORK

The present research work is proposed to be completed in three stages which has to be preceded in parallel fashion, as described below:

1. Literature Review
2. Simulation work using Optisystem version 14
3. Documentation

2.5 LAYOUT OF THE THESIS

In Chapter 1, the brief history of optical fiber communication technology, basics of optical fiber communication equipments along with an overview on PON networks, FSO technology and RSO and its working has been presented.

Chapter 2 gives us an insight to the work done in this field of optical communication based on passive optical networks, FSO and wavelength division multiplexing. The scope of this work is to build a system that can cater the need of new generation networks demanding high capacity and data rates. According to the less complex signal generation and an improved system upgrade capability of the WDM technology, it seems at the moment that this technology represents the best choice for the future system design. Also it has been found that the hybrid communication system using FSO when compared to conventional optical fiber communication systems in regions of difficult deployment resulted in better results.

Chapter 3 details the performance metrics that are used to check the performance of an optical transmission link. The relations between the performance metrics have also been discussed.

Starting with Chapter 4, an insight of the state-of-the-art technologies for higher data rates transmission systems, e.g. Optical filters, modulators, optical amplifiers and dispersion compensation techniques are given. Due to the need for an improved understanding of transmission disturbances and system upgrade aspects in 40 Gb/s and above based transmission systems, the investigations were carried out considering 40 Gb/s multi-channel propagation over long haul transmission distances. The important results of these

investigations are presented in Chapter 5 supported with accurate and to the point discussions.

Chapter 6 presents the summary of the work and gives outlook of future research activities, required for a further characterization of high speed optical transmission systems.

CHAPTER 3

PERFORMANCE METRICS

3.1 INTRODUCTION

The validation of the proposal of any optical communication system can be successfully established by applying performance checks on the system. This chapter shows simple and precise methods like BER, Q factor and eye opening which have been applied to assess the behaviour of the system.

3.2 BIT ERROR RATE (BER)

For a channel transporting binary data from transmitter to the receiver the Bit Error Rate (BER) of a fibre link is the most significant measure of the accuracy of the link. The BER gives the rate of error and is defined as the probability of an error occurring per transported bit. When the number of errors is known, the BER can be estimated as:

$$BER = (\text{number of errors})/(\text{number of transmitted bits})$$

However to calculate BER in practical situations it requires simulating trillions of bits which will make the system very complicated and time consuming. So, as an alternative of this direct approach, we estimate BER from simulation of just few bits of the order of hundreds or thousands of bits. If the BER is acceptable, then it is highly improbable that an ‘error bit’ will actually occur within the simulation time window, however for a still clearer picture we can extract basic parameters by monitoring the shape of the received eye and extracting basic parameters related to it.

Optisystem can estimate the BER using different algorithms such as Gaussian and Chi-squared.

BER and Q-factor estimation

Gaussian

Consider Gaussian noise with the standard deviations as σ_0 and σ_1 , the BER is

$$P_e = \frac{M}{N+M} P_{e0} + \frac{N}{M+M} P_{e1}$$

where P_0 and P_1 are the probabilities of the symbols, M is the number of samples for the logical 0, and N is the number of samples for the logical 1.

Also P_{e0} and P_{e1} are :

$$P_{e0} = \frac{1}{2} \operatorname{erfc} \left(\frac{S - \mu_0}{\sqrt{2}\sigma_0} \right)$$

$$P_{e1} = \frac{1}{2} \operatorname{erfc} \left(\frac{\mu_1 - S}{\sqrt{2}\sigma_1} \right)$$

where μ_0 , μ_1 , σ_0 , σ_1 and are average values and standard deviations of the sampled values respectively, and S is the threshold value.

Average Gaussian

An enhancement of the simple Gaussian approximation can be achieved by averaging the separately estimated BERs for different sampled symbols. For M sampled values for the logical 0 and N sampled values for the logical 1, the corresponding error rates are:

$$P_{e1} = \frac{1}{2N} \sum_{i=1}^N \operatorname{erfc} \left(\frac{\mu_{1i} - S}{\sqrt{2}\sigma_{1i}} \right)$$

$$P_{e0} = \frac{1}{2M} \sum_{i=1}^M \operatorname{erfc} \left(\frac{S - \mu_{0i}}{\sqrt{2}\sigma_{0i}} \right)$$

If the signal is mixed with the noise, the Average Gaussian method is modified to calculate the average error patterns. The detailed description is :

$$P_e = \sum_{i=1}^S \frac{N_p}{N} \operatorname{erfc} \left(\frac{\mu_i - S}{\sqrt{2}\sigma_i} \right)$$

Where N_p is the number of the one occurrence of any pattern, N is the total number of patterns, μ_i and σ_i are average values and standard deviations of the sampled values for each pattern respectively, and S is the threshold value.

Worst-case Gaussian

Since the Average Gaussian method can estimate the BER per bit or per pattern, the Worst-case Gaussian searches for the min BER for each bit or pattern instead of calculating the average values.

Chi-Squared

The Chi-Squared estimator is adequate for received signals with non-Gaussian statistics. The analyzer will estimate the Chi-squared parameters after statistical analysis of

the received signal. The probability of error is calculated according to:

$$P_e = \frac{M}{N + M} \int_{-\infty}^{\infty} f_{x^2}(x|0) + \frac{N}{N + M} \int_{-\infty}^{\infty} f_{x^2}(x|1)$$

The model can also calculate the average error pattern and the worst case pattern. BER and Q factor can be used interchangeably. The Q-Factor from BER is calculated numerically by:

$$P_e = \frac{1}{2} \operatorname{erfc} \left(\frac{Q}{\sqrt{2}} \right)$$

Where, the Q-Factor is calculated as

$$Q = \frac{|\mu_1 - \mu_0|}{\sigma_1 + \sigma_0}$$

The eye height is calculated as:

$$E_H = (\mu_1 - 3\sigma_1) - (\mu_0 + 3\sigma_0)$$

The eye amplitude is calculated by:

$$E_A = \mu_1 - \mu_0$$

The eye closure is calculated by:

$$E_c = \min(V_1) - \max(V_0)$$

where $\min(V_1)$ is the minimum value of the amplitude for the marks and $\max(V_0)$ is the maximum value for the amplitude of the spaces.

The eye-opening factor is calculated by:

$$E_0 = \frac{(\mu_1 - \sigma_1) - (\mu_0 - \sigma_0)}{(\mu_1 - \mu_0)}$$

The extinction ratio is calculated by:

$$E_R = \frac{\mu_1}{\mu_0}$$

3.3 EYE DIAGRAM ANALYSER

The eye diagram is considered to be a mark of the credibility as a carrier of information. It consists of many cases of the signals one displayed over the other.

The following aspects of the eye are important:

- 1 The vertical height of eye opening gives the amount of difference in signal level that is present to point to the difference between one-bits and zero-bits. The bigger the difference, the easier it is to discriminate between one and zero. However, this is affected extensively by noise in the system.
- 2 The horizontal eye opening gives the amount of jitter present in the signal. The wider the eye opening is on this axis, the lesser is the jitter issue.
- 3 The thickness of the band of signals at the zero-crossing point is also good measure of jitter in the signal.
- 4 Larger is the eye opening better is the signal, closed eye suggests deteriorated signal.

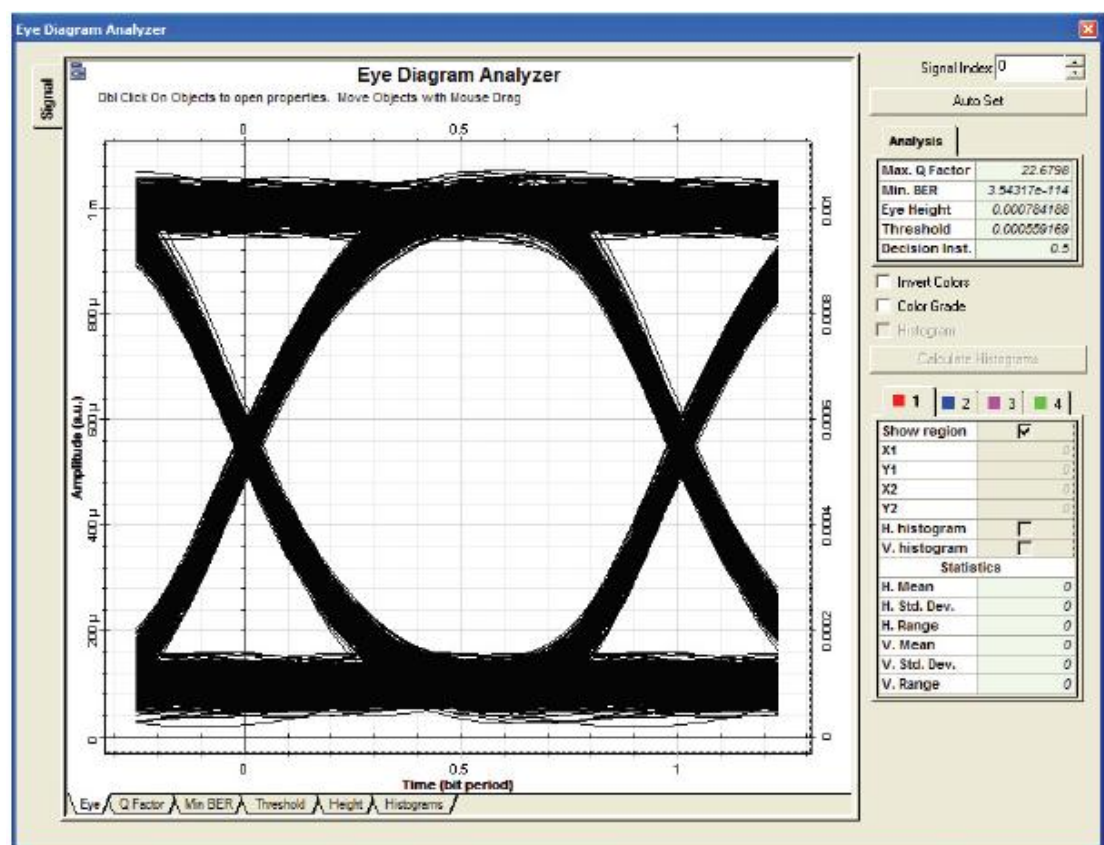

Figure 3.1: Eye diagram Analyzer

The available results in the display are:

- Max Q-factor: Maximum value for the Q-factor in the eye time window.
- Min BER: Minimum value for the bit error rate in the eye time window.
- Eye height: Maximum value for the eye height in the eye time window.

- Threshold: Value of the threshold at the decision instant for the max Q-factor/min BER
- Decision inst: Value of the decision instant for the maximum Q-factor/minimum BER.

CHAPTER 4

SIMULATION MODEL FOR HYBRID (DWDM-PON AND FSO) NETWORK

4.1 INTRODUCTION

Now a days, FTTH (Fiber-To-The Home) systems are being installed at a large scale to get benefits of high bandwidth and more services [57]. Systems being installed majorly are based on PONs. 10G-PON as per ITU-T G.987 works at 10 Gb/s downstream and 2.5 Gb/s upstream. Recently, the interest of research is XG-PON, the new age PON networks marking an optical access networks migration from GPON to XG-PONs [58].

Current communication systems which include both electrical and optical components operate at bit rates from 10 Mb/s to 2.5 Gb/s. These rate while seem sufficient for today, will not suffice in coming time as per the new services coming in the market. Data highways of future systems will require rates close to 100 Gb/s. This work aims to take a step forward in this direction by simulating such a network with multi-user capability offering a speed of 40 Gb/s in downstream direction and 10 Gb/s in upstream direction.

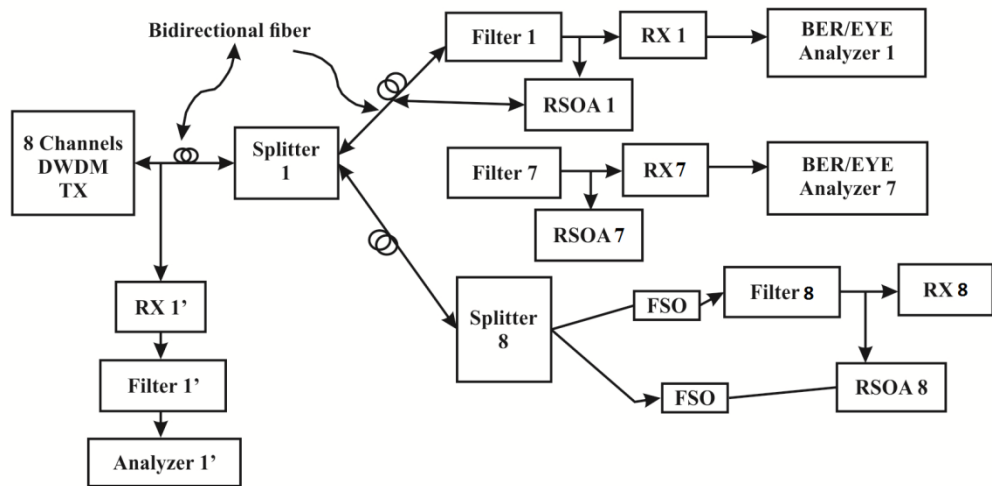

Figure 4.1: Block diagram of simulation setup of bidirectional DWDM-PON for 8 channels

4.2 SYSTEM DESCRIPTION

The DWDM-PON provides high bandwidth for each user and supports multiple channels. Figure above shows the block diagram of simulation setup of bidirectional DWDM-PON for 8 channels. The block diagram shows 8 DWDM channels transmitted each at -3dB input power and modulated by different modulation formats from optical line terminal (OLT) and

multiplexed with the help of optical multiplexer and transmitted through bidirectional fiber (BD). The output of BD fiber goes to splitter which separates each channel as transmitted from OLT and received by different receiver with filter bandwidth 3.5GHz. Now, again all channels are fed at -10dB input power inserted into reflecting semiconductor optical amplifier (RSOA). The RSOA re-modulates and re-amplify the signal and feed the signal back to bidirectional fiber. RSOA has the crucial task of re-modulating the received downstream signal with the new upstream signal which decides the effectiveness of the system. The high-pass filtering effect of the RSOA, which tends to be more pronounced at higher input powers, can be used to suppress the downstream signal. The figure 4.2 shows the simulation setup of bidirectional DWDM-PON for 8 channels.

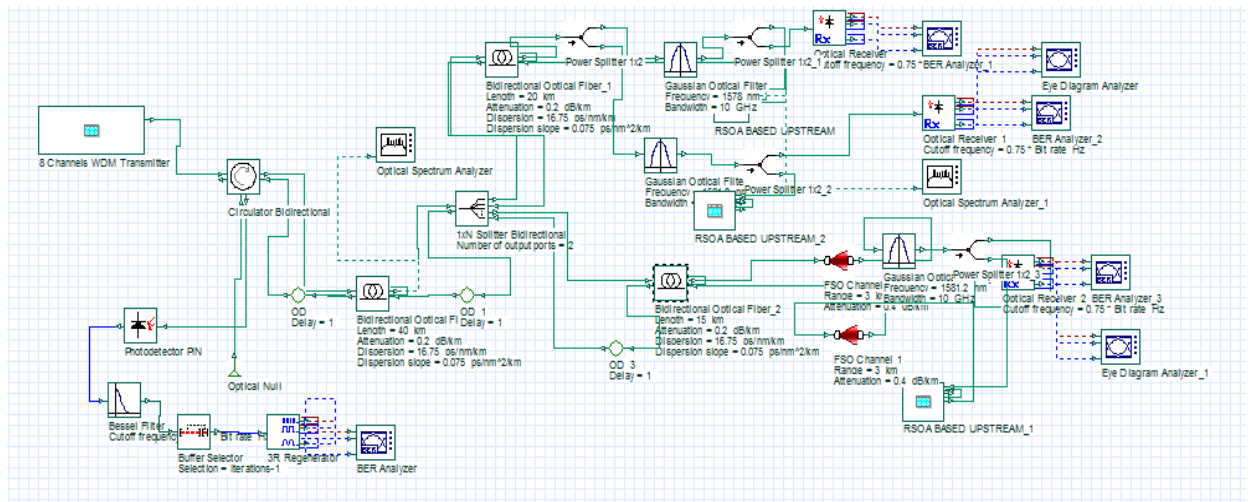

Figure 4.2: Simulation setup of bidirectional DWDM-PON for 8 channels in OPTISYSTEM

The different key parameters have been setup as shown in the table 4.1 below.

Table 4.1: System Description

Parameters	Description
Number of channels	8
Channel spacing	0.4nm
Filter Bandwidth	3.5GHz in down link & 2.5GHz in up link
Data rate per channel in down stream	40GB/s
Data rate per channel in up stream	10GB/s

Pattern length	2^9
Modulation format in down stream	Varied
Modulation format in up stream	Varied
Bidirectional fiber length	40km + 20km

4.2.1 Optical Transmitter

4.2.1.1 -Transmitter at OLT side

Optical Transmitter comprises of 8 Channels DWDM transmitters, which is amplified with EDFA at gain 20dB. The eight channel WDM transmitter is shown in figure below.

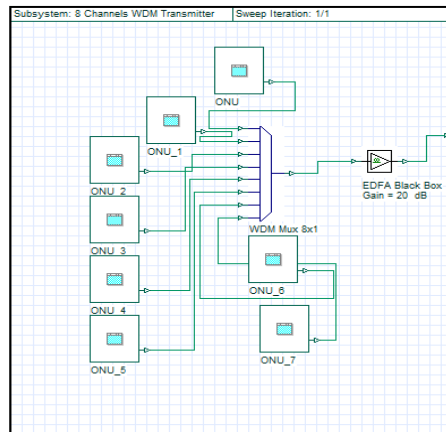

Figure 4.3 8-channel DWDM transmitter

Here, initially RZ transmitter is used at 10 Gb/s data rate then it increases to 40 Gb/s using different modulation formats. The channel spacing between the two adjacent wavelengths is 0.4nm whereas data rate per channel are set at 40Gb/s and 10Gb/s for downstream and upstream respectively. The Optical Line Terminal (OLT) components for single channel are shown in figure below. External modulator is used for providing 180 degree phase shift to each channel.

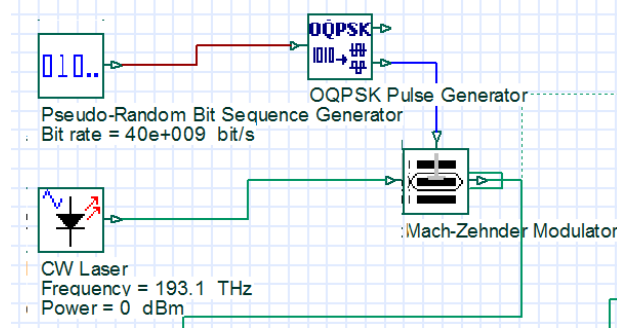

Figure 4.4: OLT components for single channel

4.2.1.2 Transmitter at ONU side

The Semiconductor Optical Amplifier (SOA), as well as a Reflective SOA (RSOA) are highly nonlinear and can be used for signal amplification, signal modulation, and optical signal processing applications such as wavelength conversion, switching and optical time domain De-multiplexing. The RSOA has two input ports and one output port. The first input accepts optical signals, which can consist of one or more optical channels. The second input accepts an optional electrical modulation current. Finally, the output port generates the resulting output optical signal. RSOA does not support CW optical signals for re-modulation. All signals input to the RSOA must have identical time steps and number of data points, if the user connects an electrical modulation. In OptiSystem, RSOA has three ports i.e. Two Bidirectional Optical ports and one bidirectional Electrical Port. RSOA modulates and amplifies the signal. The component model is based on the numerical solution of a set of coupled differential equations that describe the interaction between the carrier density and photon rates along the active layer length. The value of the injection current here is considered as an input signal allowing the modulation of the optical signal by the SOA [59].

This component also considers the possibility of sensing the differences in voltage produced at the bias electrode of the single-section SOA. In this case the voltage variation is defined by the following equation :

$$V_{\phi} = nj \frac{K_B T}{e} \ln \left[\frac{N_{bias}(z) + N(z)}{N_{bias}(z)} \right]$$

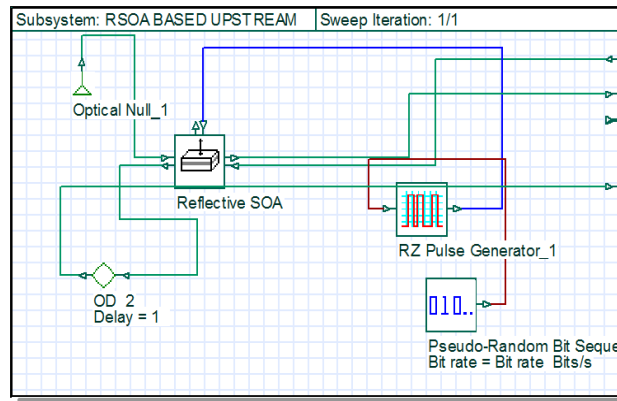

Figure 4.5: RSOA subsystem

The Figure 4.5 shows the RSOA subsystem diagram. As per the system setup with the key parameters shown in table 4.1, the results and related discussion are summarized in the following section.

4.2.1.3 Mach-Zehnder Modulator

Based on interferometric principle, Mach-Zehnder modulator is basically an intensity modulator. Its constructed using two 3 dB couplers which are connected by two waveguides of equal length. By an externally applied voltage, the refractive indices of the waveguide branches can be changed by a phenomenon called electro-optic effect. This voltage applied on different paths decides the constructive and destructive interference at the output. Based on this voltage output intensity can be modulated.

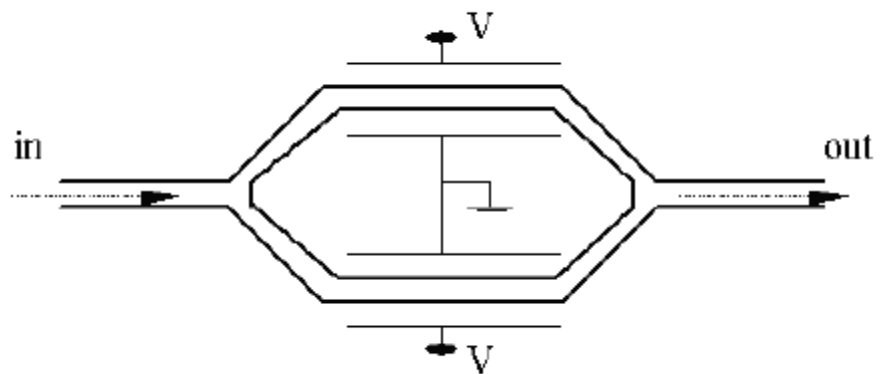

Figure 4.6 : Mach-Zehnder modulator

4.2.2 FSO Channel

This component allows for simulation of free space optical links. The component is equivalent to a transmitter telescope, in between free space and receiver telescope. Its parameter *Range* defines the propagation distance between transmitter and

receiver. The attenuation of the laser power depends on two main parameters: *Attenuation* and *Geometrical loss*. The first parameter describes the attenuation of the laser power in the atmosphere. The second parameter, Geometrical loss, occurs due to the spreading of the transmitted beam between the transmitter and the receiver.

$$P_{Received} = P_{Transmitted} \frac{d_R^2}{(d_T + \theta R)^2} 10^{-\alpha R/10}$$

Where:

d_R : Receiver aperture diameter(m)

d_T : Transmitter aperture diameter(m)

θ : Beam divergence(mrad)

R :Range (km)

α :Atmospheric attenuation(dB/km)

CHAPTER 5

RESULTS AND DISCUSSION

The work in this thesis involves simulating high speed DWDM-PON/ FSO network. In WDM-PON 8 channels with different wavelengths are transmitted at 40 Gb/s. The 8 DWDM channels were separated by 50GHz (0.4nm). Table 5.1 shows the BER values for channel 1 and channel 8 with their respective eye diagram.

Table 5.1: BER and Eye Diagram of Channel 1 & 8 for Downstream

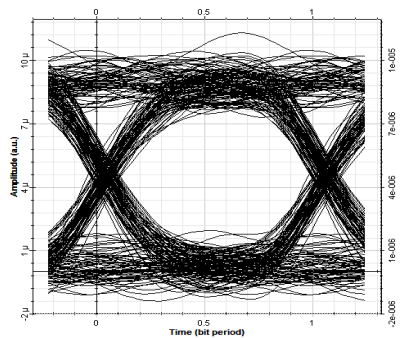
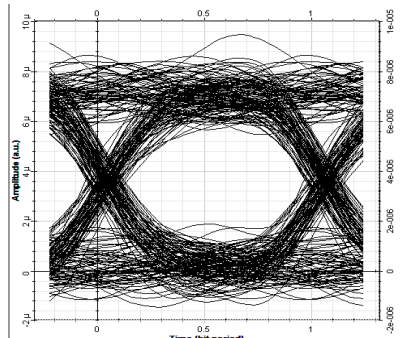
Channel	BER	Eye Diagram
1 (1578nm)	1.71e-13	
8(1581.2nm)	3.84e-09	

Similarly, the BER and Eye diagram of channel 1 & 8 for upstream is shown in table 5.2. In which the data rate is kept at 10 Gb/s. For simplicity, two channels i.e. first channel at 1578nm and 8th channel at 1581.2nm have been seen to measure the performance of the designed system in downlink direction.

Table 5.2: BER and Eye Diagram of Channel 1 & 8 for Upstream

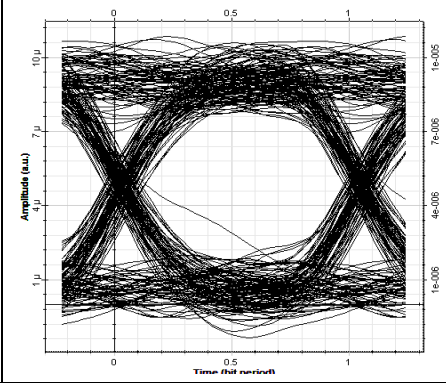
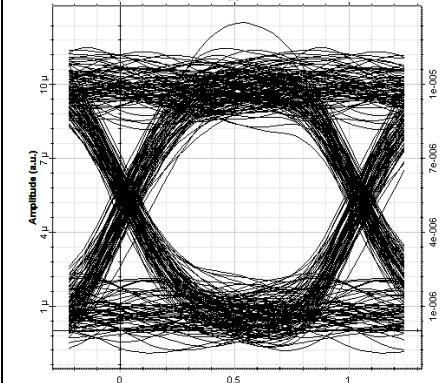
Channel	BER	Eye Diagram
1(1578nm)	3.21e-11	
8(1581.2nm)	1.00e-13	

It has been observed that BER of the order of e-13 and e-09 has been analyzed for channel 1 and 8 respectively in downstream direction. Also, BER of the order of e-11 and e-13 has been analyzed for reflected wavelength of 1578nm and 1581.2nm respectively and the eye is open in both the cases.

To optimize the performance of the above mentioned designed system, the various parameters have been varied in both the cases i.e. downstream and upstream. The effect of changing the modulation techniques is observed and found that there is an improvement in BER value of channels 1 & 8 for CRZ modulation format, as shown in table 5.3.

Table 5.3: BER for different modulation formats at different wavelengths for (8X40) 320 GB/s at 60km in down link transmission

Lambdas (λ)	Wavelengths (nm)	Modulation Formats				
		NRZ	RZ	CSRZ	CRZ	OQPSK
1	1578	3.767e-10	1.71e-13	1.2573e-9	3.1662e-14	1.7206e-21
8	1581.2	1.4179e-8	3.84e-9	2.144e-8	1.5700e-10	6.5732e-16

Similar observations have been carried out for different modulation formats at different wavelengths for 80GB/s at 60km fiber length in upstream transmission. RSOA's bandwidth is limited to GHz due to its carrier lifetime in the active layer. Recently, to enhance their data rates many proposals have landed out of which one is to use advanced modulation formats. The results are shown in Table 5.4

Table 5.4: BER for different modulation formats at different wavelengths for (8X10)80GB/s at 60km fiber length in upstream transmission

S. No.	Wavelengths (nm)	Modulation formats		
		CRZ	RZ	NRZ
		BER	BER	BER
λ_1	1578.0	1.6632e-20	3.21e-11	5.7146e-09
λ_8	1581.2	1.8573e-18	1.e-13	2.4247e-09

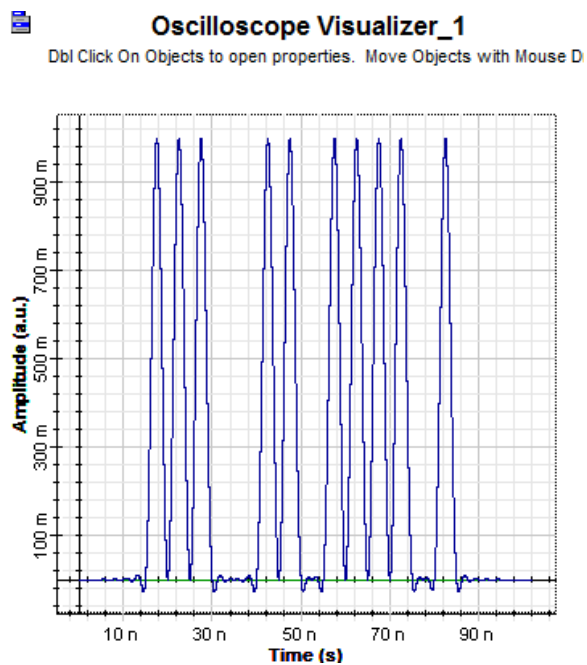

Figure 5.1: CRZ Format

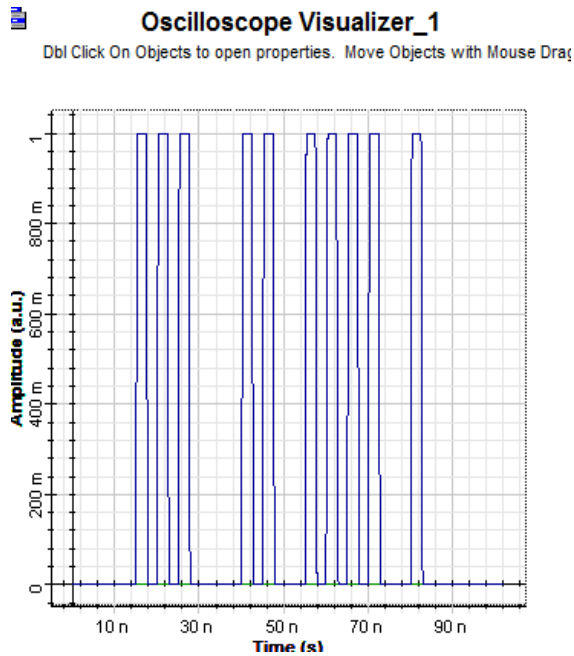

Figure 5.2: RZ Format

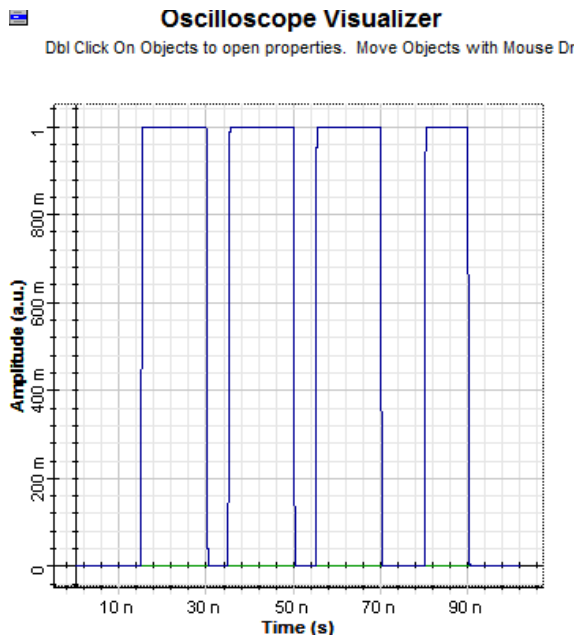

Figure 5.3: NRZ Format

For channel 1 obtained values of BER are 3.7674×10^{-10} , 1.71×10^{-10} , 1.71×10^{-9} , 3.1662×10^{-12} and 1.7206×10^{-21} for NRZ, RZ, CSRZ, CRZ modulation format at 60km fiber length in down link transmission. Similarly for channel 8 obtained BER values are 1.4179×10^{-8} , 3.84×10^{-9} , 2.144×10^{-8} , 1.5700×10^{-10} and 6.5732×10^{-16} for CRZ, RZ, NRZ and CSRZ for same fiber length. Similarly, in upstream for channel 1 BER is 1.6632×10^{-20} , 3.21×10^{-11} and 5.7146×10^{-9} for CRZ, RZ and NRZ formats whereas for channel 8 it is 1.8573×10^{-18} , 1×10^{-13} and 2.4247×10^{-9} . It has been observed that CRZ is best for upstream and downstream direction.

Further, it is analyzed that at 10 Gb/s data rate give less BER however for 40 Gb/s the results obtained for both the channels are also within acceptable limits, as shown in Table 5.5.

Table 5.5: BER for OQPSK modulation at different data rates in downstream transmission

Lambdas (λ)	Data Rate	Modulation
		OQPSK
1	10Gb/s	1.7206e-21
8		6.5732e-16
1	40Gb/s	3.324e-12
8		1.000e-09

Similar observations have been taken for upstream transmission keeping CRZ modulation format and seen the channel 1 & 8 response. From Table it has been observed that if the data rate increases BER also increases. We observe that channel 1 and channel 8 have BER values e-21 and e-16 for 10 Gb/s at 60km fiber length. For 40 Gb/s in same channels we obtained BER value e-12 and e-09 at 60km fiber length in down link. Similarly in uplink for channel 1 and channel 8 obtained BER values are e-20 and e-18 for 5 Gb/s. At 10GB/s for same channels observed BER values are e-11 and e-9 at 60km fiber length for OQPSK modulation, so there has to be a tradeoff between BER and data rate. If we increase data rate BER also increases. The results are shown in table 5.6.

Table 5.6: BER at different data rates for CRZ modulation format in uplink transmission

S. No.	Data Rate	Wavelengths (nm)	Modulation
			formats
			CRZ
			BER
λ_1	5 Gb/s	1578.0	1.6632e-20
λ_8		1581.2	1.8573e-18
λ_1	10Gb/s	1578.0	3.242e-11
λ_8		1581.2	2.331e-09

Another aspect of analyzing the system is to vary the total link length in OQPSK modulation at 40 Gb/s data rate in downstream transmission. The result for the same is shown in table 5.7.

Table 5.7: BER at 40Gb/s for different total network length

Lambdas (λ)	Data Rate	Total Network Length	Modulation OQPSK
1	40Gb/s	40Km	2.131e-18
8			4.242e-16
1		60 Km	3.324e-12
8			1.000e-9
1		80Km	2.424e-8
8			6.453e-4

At total network length of 60 km the BER value of channel 1 & 8 is 3.324e-12 and 1.000e-9 at data rate of 40 Gb/s. This result is the optimized result for downstream.

Bessel filter offers excellent pulse response i.e. minimal over shoot and ringing due to linear phase response. Also, in comparison to other filters it offers slower initial rate of attenuation beyond the pass band. [35]

Using different filter such as Bessel filter, Butterworth and Chebyshev filters, for the current scenario, it is found that the BER value for channel 1 & 8 is best for Bessel filter as shown in Table 5.8

Table 5.8: BER Value for different filter at 40 Gb/s / 60 km downstream

Lambdas (λ)	Data Rate/Distance	Filter Type Downlink	BER
1	40Gb/s/60km	Low Pass Bessel	2.244e-14
8			3.444e-10
1		Low Pass Butterworth	3.324e-12
8			1.000e-9

1		Low Pass Chebyshev	2.452e-8
8			2.131e-6

The bandwidth of Bessel filter is defined by the range of frequency where the transfer function falls below 3 dB. The minimum BER for low pass Bessel filter is found to be e-14 which is acceptable in case of 8 channels in downlink. Dispersion is major factor in long haul communication with high data rates. Broadening of light pulses is called dispersion. It is clear that dispersion increases with the increase in distance. The eye opening at a distance of 40 km is very broad, shows less interference and distortion. At the distance of 80 km, the opening of eye is not clear shows more dispersion and interference. Further it is important to note that due to dispersion, BER increases. To compensate it, dispersion compensation technique has been used at the receiver end. Electronic Equalization technique is used before the receiver to improve modulation bandwidth of an RSOA based colorless optical network unit. Electronic Equalization Technique helps to improve downlink and uplink performance. The dispersion compensation technique i.e. Electronic Equalization, reduces the BER value as shown in Table 5.9

Table 5.9: BER at 40Gb/s data rate using Dispersion Compensation

Lambdas (λ)	Data Rate	Dispersion Compensation at receiver	BER
1	40Gb/s	Electronic Equalization	2.442e-18
8			3.444e-12

The result shown in Table 5.9 for channel 1 & 8 can be compared with the result shown in Table 5.8 for channel 1 & 8 for low pass filter downlink. The BER value after dispersion compensation is 2.442e-18 and 3.444e-12 for channels 1 & 8 respectively. Whereas BER value before compensation is 2.244e-14 and 3.444e-10 for channels 1 & 8 respectively. In both the channels, BER value is reduced after dispersion compensation.

The system implemented is a bidirectional DWDM-PON using RSOA whose effects have been evaluated on the performance of upstream signal. By changing the RSOA pump current at 10 Gb/s data rate in upstream transmission, BER of the system has been recorded.

The system response at different RSOA pump current is measured in terms of BER at data rate of 10 Gb/s in upstream as shown is recorded in Table 5.10

Table 5.10: BER at different RSOA pump current for data rate of 10 Gb/s

Lambdas (λ)	Data Rate	Length	RSOA Pump Current	BER
1	10Gb/s	60Km	30mA	3.242e-11
2				2.331e-09
1			40mA	2.242e-14
2				4.241e-12
1			50mA	1.324e-10
2				2.134e-8

Electrons are raised from a lower energy level to a higher one through the process called “pumping”. Population inversion is achieved when number of electrons increase in the excited or higher energy state. This phenomenon is commonly used in laser construction. For channel 1 and channel 8 the observed values of BER are e-11 and e-9 at 30mA RSOA pump current. For the same channels we observe BER values are e-14 and e-12 at 40mA pump current.

If we further increase RSOA, pump current population inversion cannot take place hence BER also increases. The obtained BER values are e-10 and e-8 at 50mA pump current. So, we conclude that 40mA pump current value of RSOA is the optimum value for transmission. Similar analysis is performed for electrical modulation current (I_{mod}) for RSOA pump current at 40mA and the results are shown in Table 5.11

Table 5.11 : BER at 10 Gb/s upstream for different electrical modulation current

Lambdas (λ)	Data Rate	RSOA Pump Current	RSOA I_{mod} Current	BER
---	------------------	----------------------------------	--	------------

1	10 Gb/s	40mA	160mA	1.324e-10
2				2.423e-8
1			180mA	2.242e-14
2				4.241e-12
1			200mA	1.002e-16
2				4.242e-10

If the user connects an electrical modulation current (I_{mod}) to the RSOA, then it is added to the specified Pump Current to form the total injection current:

$$RSOA_{Total\ current} = PUMP\ current\ (mA) + I_{mod}\ current\ (mA)$$

It is observed that increasing the I_{mod} current leads to reduction in the BER. For example the obtained value of BER is e-14 for 180mA I_{mod} current for channel 1 for same channel we obtained a value of e-16 at 200mA I_{mod} current for same fiber length. So if we increase I_{mod} current the BER decreases. At 200mA I_{mod} current and 40mA RSOA Pump current, we observed the BER at different extinction ratio (ER) which is shown in Table 5.12

Table 5.12: BER at optimized RSOA pump current and electrical modulation current for various ER

Lambdas (λ)	Data Rate	RSOA Pump Current	RSOA Imod Current	ER(dB)	BER
1	10 Gb/s	40mA	200mA	3dB	3.435e-20
8					1.222e-14
1				4dB	2.444e-18
8					1.213e-12
1				5dB	1.002e-16
8					4.242e-10

CHAPTER 6

SUMMARY OF RESULTS & FUTURE SCOPE

6.1 INTRODUCTION

The world today is growing global and there is an increasing demand for high speed connections for services like television (IPTV) and video on demand (VoD) over Internet together with high speed Internet access (HSI), to which the best solution is Fiber based access networks. Fiber to the Home (FTTH) is probably the most suitable option for a long reach network with high bandwidth demand. The DWDM-PONs are harbingers of the future of next generation optical networks. These systems allow multiple users to access high bandwidths. In this chapter the results obtained from investigations have been summarized in section 6.2 followed by key recommendations in section 6.3 and future scope of the work in section 6.4

6.2 SUMMARY OF RESULTS

It is successfully demonstrated that DWDM-PON can be effectively implemented for 60 Kms in a hybrid network. It delivers downstream 40 Gb/s and upstream 10 Gb/s data rate for 8 users separated by channel spacing of 0.4 nm (50 GHz) as per the ITU standards. To perform this function, OQPSK is found to be the most suitable modulation scheme for downstream data whereas CRZ is recommended for upstream communication. RSOA has proven to be a good candidate as it allows the signal to be directly modulated and amplified at the same time without using any external modulator. It gives optimized results for pump current close to 40 mA and extinction ratio up to 5 dB. For I_{mod} current, as it increases the BER decreases, however for $I_{\text{mod}} = 200\text{mA}$, we get desired values for BER. Use of electronic equalization to combat dispersion has resulted in improved BER values. For downstream, low pass Bessel filter gives optimum filtering. The results are summarized as follows:

- Due to the carrier lifetime in the active layer, the modulation bandwidth of the RSOA is limited to GHz. Recently, there have been several attempts to operate these low bandwidth devices at 10Gb/s and beyond using advanced modulation formats. It has been observed that OQPSK modulation format is best format for downstream and CRZ is best for upstream direction.
- Next for the given system optimal data rate and network length were examined. It was observed that for downlink channels 1 and 8 at 40 Gb/s and network length of 60 km, the BER obtained were $3.324\text{e-}12$ and $1.000\text{e-}9$. While for uplink channels 1 and 8 at 10 Gb/s and network length of 60 km the BER was $3.242\text{e-}11$ and $2.331\text{e-}09$.

- BER for low pass Bessel filter is found to be e^{-14} which is acceptable in case of 8 channels in downlink.
- The eye opening at a distance of 40 km is very broad, shows less interference and distortion. At the distance of 80 km, the opening of eye is not clear shows more dispersion and interference. Dispersion leads to increase in BER. To compensate it, dispersion compensation technique has been used at the receiver end. Electronic Equalization technique is used before the receiver to improve modulation bandwidth of RSOA hence improving the downlink and uplink performance. An electronic equalizer works at attenuating ISI caused by chromatic dispersion and polarization mode dispersion in single mode fibers, or differential mode delay in case of multimode fibers.
- Electrons are raised from a lower energy level to a higher one through the process called “pumping”. For channel 1 and channel 8 the observed values of BER are e^{-11} and e^{-9} at 30mA RSOA pump current. For the same channels we observe BER values are e^{-14} and e^{-12} at 40mA pump current. If we further increase RSOA, pump current population inversion cannot take place hence BER also increases. The obtained BER values are e^{-10} and e^{-8} at 50mA pump current. So, we conclude that 40mA pump current value of RSOA is the optimum value for transmission.

Total injection current of an RSOA is sum of pumping current and modulation current. Extinction ratio is another factor taken into consideration which is ratio of two optical power levels generated. For pumping current 40mA, modulation current 200mA and ER 4dB we get optimised BER of $2.44e^{-18}$ and $1.213e^{-12}$.

6.3 FUTURE SCOPE

- RSOA offers us the advantage of reducing expenditure with wavelength reuse scheme, while using XG-PON network however using RSOA based networks carry a disadvantage of crosstalk between the upstream and downstream signals. We have used orthogonal modulation formats for upstream and downstream however the BER can be further improved by erasing the downstream signal completely before re-modulating it or by allocating different bands for both directions.
- Rayleigh scattering though doesn't bring a change in wavelength but can also be considered for better system designing as it results in interference. The downstream scattered signal interferes with the upstream while the backscattered upstream has chances of being re-modulated by RSOA and interfering again.

- Analysis of free space optics under weather conditions like haze, rain snow and fog can be done in order to extend the present research.
- Temperature control is required because wavelength tend to change with environmental temperatures, can enhance the system efficiency.

REFERENCES

- [1] L. Hutcheson and Ovum (2008). FTTx: Current Status and the Future, *IEEE Communications Magazine*, 46(7), 90-95.
- [2] Deeksha Kocher. Investigation of FTTH architectures based on Passive optical networks. *M.Tech. Thesis, Thapar University, Patiala, India, 2012.*
- [3] E.B. Desurvire (2006). Capacity Demand and Technology Challenges for Lightwave Systems in the Next Two Decades, *Journal of Lightwave Technology*, 24(12), 4697-4710.
- [4] E. Harstead and R. Sharpe (2012). Future fiber-to-the-home bandwidth demands favor time division multiplexing passive optical networks, *IEEE Communications Magazine*, 50(11), 218-223.
- [5] G. Kramer *et al.* (2012). Evolution of Optical Access Networks: Architectures and Capability Upgrades, *IEEE Proc*, 100(5).
- [6] S. Chatzi *et al.* (2010). Techno-economic Comparison of Current and Next Generation Long Reach Optical Access Networks. *Conference IEEE Proc., CTTE.*
- [7] Soo-Jin Park *et al.* (2004). Fiber-to-the-home services based on wavelength? Division-Multiplexing Passive Optical Network, *Journal of Lightwave Technology*, 22(11), 2582-2591.
- [8] Arsalan Saljoghei *et al.* (2013). Hybrid Wired/Wireless OFDM-PON with Direct Modulation of Integrated Lasers employing Optical Injection, *IEEE*, pp-97.
- [9] Maria C. Yuang *et al.* (2010). Next-Generation Broadband Optical Access Network Technologies, *IEEE Journal on Selected Areas in Communications*, 28(6), 733-8716.
- [10] Frank Aurzada *et al.* (2013). Capacity and Delay analysis of Next Generation Passive Optical Networks, pp-1311.
- [11] Nitish Verma *et al.* (2011). Performance analysis of FTTH Gigabit Ethernet Passive Optical Network (GEPON) system with triple play services, *International Journal of Electronics and Communication Technology, IJECT*, 2(3), 223.
- [12] A. Kaur *et al.* (2013). Comparison of RZ and NRZ Data Formats for Co-Existing GPON and XG-PON System, *International Conference on Advanced Nanomaterials & Emerging Engineering Technologies*, pp. 666-669.

- [13] Ansari N., Zhang and J. *Media Access Control and Resource Allocation for Next Generation Passive Optical Networks*, 2013.
- [14] Luo *et al.* (2013). Time and Wavelength Division Multiplexed Passive Optical Network (TWDM-PON) for Next Generation PON Stage 2 (NG-PON2), *IEEE Journal of Lightwave Technology*, 31(4), 587-593.
- [15] ITU-T Recommendation G.989.3 draft for discussion, 40-Gigabit-capable passive optical networks (NG-PON2): Transmission convergence layer specification, Dec. 2013.
- [16] Cheng-Xiang Wang *et al.* (2004). Cellular architecture and key technologies for 5G wireless communication networks, *IEEE Communications Magazine*, 52(2) 122-130.
- [17] Orawan Tipmongkolsilp, Said Zaghoul and Admela Jukan (2011). The evolution of cellular backhaul technologies: current issues and future trends, *IEEE Communications Surveys & Tutorials*, 13(1), 97-13.
- [18] Cheng Liu *et al.* (2014). Key Microwave-Photonics Technologies for Next-Generation Cloud-Based Radio Access Networks, *IEEE/OSA Journal of Lightwave Technology*, 32(20), 3452-3460.
- [19] E. Leitgeb, *et al.* Current Optical Technologies for Wireless Access, *Conference IEEE Proc, ConTel 2009*).
- [20] E. Ciaramella *et al.* (2009). 1.28 Terabit/s (32x40 Gbit/s) WDM Transmission System, *IEEE Photonics Technology Letters* 21 (16), 1121-1123
- [21] S. Bloom *et al.* (2003). Understanding the performance of free-space optics, *Journal of Optical Network*, 2(6), 178-200.
- [22] D.M. Forin *et al.* (2007) On field test of a Wavelength Division Multiplexing Free Space Optics transmission at very high bit rate, *Conference IEEE Proc., ConTel*.
- [23] T. V. Nguyen *et al.* (2016). Performance analysis of gigabit-capable mobile backhaul networks exploiting TWDM-PON and fso technologies, *International Conference Adv. Technol. Commun.*, pp. 180-185,
- [24] J. E. Mitchell (2014). Integrated Wireless Backhaul Over Optical Access Networks, *Journal of Lightwave Technology*, 32(20), 3373-3382.

- [25] M. A. Khalighi and M. Uysal (2014). Survey on Free Space Optical Communication: A Communication Theory Perspective, *IEEE Communications Surveys & Tutorials*, 16(4), 2231-2258.
- [26] Y. Li, M. Pióro and V. Angelakisi, Design of cellular backhaul topology using the FSO technology, 2nd International Workshop on Optical Wireless Communications (IWOW), *Newcastle upon Tyne*, pp. 6–10 (2013).
- [27] Y. Li *et al.* (2014). Resilient topology design for free space optical cellular backhaul networking, *IEEE Globecom Workshops, Austin*, pp. 487–492.
- [28] Q. Liu *et al.* (2005). Optical wireless communication networks for first- and last-mile broadband access, *OSA Journal of Optical Networking*, 4(12), 807-828.
- [29] Y. Takushima, K. Y. Cho and Y. C. Chung (2008). Design issues in RSOA- based WDM PON, *IEEE Photon. Global Conference*, C-34–C-37.
- [30] G. Valicourt *et al.* (2011) 10-Gbit/s modulation of reflective SOA without any electronic processing, *Opt. Fiber Communication Conference*.
- [31] G. Valicourt *et al.* 10 Gbit/s modulation of reflective SOA without any electronic processing, *OFC*, 2011,
- [32] M. Omella, *et al.* 10Gb/s RSOA transmission by direct duobinary modulation, *ECOC*, 2008.
- [33] T. Duong, *et al.* (2008) Experimental demonstration of 10 Gbit/s upstream transmission by remote modulation of 1 GHz RSOA using adaptively modulated optical OFDM for WDM-PON single fiber architecture, *ECOC*.
- [34] J. Wei *et al.* (2010). Wavelength reused bidirectional transmission of adaptively modulated optical OFDM signals in WDM-PONs incorporating SOA and RSOA intensity modulators, *Opt. Exp.*, 18(10), 9791-9808.
- [35] K. Y. Cho, Y. Takushima and Y. C. Chung (2010). Enhanced chromatic dispersion tolerance of 11-Gb/s RSOA-based WDM PON using 4-ary PAM signal, *Electron. Lett.*, 46(22), 1510-1512.
- [36] K. Y. Cho, Y. Takushima, and Y. C. Chung (2008). 10-Gb/s operation of RSOA for WDM PON, *IEEE Photon. Technol. Lett.*, 20(18), 1533-1535.
- [37] A. Agata and Y. Horiuchi, RSOA-based 10 GWDMPON using FEC and MLSE equalizers, *OFC*, 2010, paper OWG3.

- [38] Q. Guo, A. V. Tran and C.-J. Chae (2011). 10-Gb/s WDM-PON based on low-bandwidth RSOA using partial response equalization, *IEEE Photon. Technol. Lett.*, 23(20), 1442-1444.
- [39] A. Chenika, A. Temmar and O. Seddiki (2014). Transmission of 4X 40/10 Gbps in a WDM-PON using NRZ-DQPSK/ASK modulation, *Optik (Stuttg)*, 125(20), 6296-6298.
- [40] S. H. Cho *et al.* (2012). Mitigation of interferometric crosstalk by using a single mode laser with optical feedback in a loop-back WDM-PON based on RSOA, *Opt. Fiber Technol.*, 18(6), 523-526.
- [41] P. K. Choudhury (2015). Improved noise tolerance and spectral efficiency in RSOA based WDM-PON by using Miller signal, *Opt. Quantum Electron.*, 47(3), 595-602.
- [42] M. Fujiwara *et al.* (2009). Loss budget in single-fiber loopback access networks with ASE light source considering gain compression effect of GS-SOA, *IEICE Electron. Express*, 6(2), 65-70.
- [43] T. B. Gibbon *et al.* (2011). VCSEL transmission at 10 Gb/s for 20 km single mode fiber WDM-PON without dispersion compensation or injection locking, *Opt. Fiber Technol.*, 17(1), 41-45.
- [44] K. P. Kaur, R. Randhawa, and R. S. Kaler (2014). Performance analysis of WDM-PON architecture using different receiver filters, *Optik (Stuttg)*, 125(17), 4742-4744.
- [45] R. M. Mu *et al.* (2002). Dynamics of the chirped return-to-zero modulation format, *J. Light. Technol.*, 20(1), 47-57.
- [46] Randeep Kaur and Nitika Soni (2017). A Review of Passive Optical Networks, *International journal of Advanced Technology in Engineering and Science*, 5(1), 32-39.
- [47] L. Tawade, S. Mhatli, and R. Attia (2015). Bidirectional long reach WDM-PON delivering downstream data 20 Gbps and upstream data 10 Gbps using mode locked laser and RSOA, *Opt. Quantum Electron.*, 47(3), 779-789.
- [48] E. Udvary, A. Schranz, and B. Matolcsy. Dispersion and off-set filtering in RSOA based networks, *Int. Conf. Transparent Opt. Networks*, 2016.
- [49] Z. Al-Qazwini and H. Kim (2012). Symmetric 10-Gb/s WDM-PON using directly modulated lasers for downlink and RSOAs for uplink, *J. Light. Technol.*, 30(12), 1891-1899.

- [50] Z. Al-Qazwini, M. Thollabandi, and H. Kim (2013). Colorless optical transmitter for upstream WDM PON based on wavelength conversion, *J. Light. Technol.*, 31(6), pp. 896-902.
- [51] M. Al-Quzwini (2014). Design and Implementation of a Fiber to the Home FTTH Access Network based on GPON, *Int. J. Comput. Appl.*, 92(6), 30-42.
- [52] S. Di Bartolo *et al.* (2014). Experimental demonstration of a GPON free space optical link for full duplex communications, *Fotonica AEIT Italian Conference on Photonics Technologies*, Naples, pp. 1-3.
- [53] J. Zhou *et al.* (2014). Design of adaptive dispersion compensation and demodulation system for 40Gbps RZ-DQPSK optical fiber communication receivers, *Opt. - Int. J. Light Electron Opt.*, 125(1), 370-373.
- [54] Kaikai Xu and Yang Ou (2015). Theoretical and numerical characterization of a 40Gbps long-haul multi-channel transmission system with dispersion compensation, *Digit. Commun. Networks*.
- [55] Recommendation ITU-T G.671, *Transmission Characteristics of Optical Components and Subsystems*, 2009.
- [56] L. Hutcheson, Ovum FTTH: current status and the future, *IEEE Communication Mag.* www.comsoc.org, 2008
- [57] ITU-T G.984 Available at <http://www.itu.int> (Accessed on 14th march 2017).
- [58] Michael J. Connelly (2001). Wideband Semiconductor Optical Amplifier Steady-State Numerical Model. *IEEE Journal of Quantum Electronics*, 37(3).

LIST OF PUBLICATIONS

- 1) Ashima, RS Kaler, "Performance Optimization of RSOA based High Speed Backhaul XG-PON Hybrid (DWDM-PON/ FSO) Network" communicated to *Optik - International Journal for Light and Electron Optics*.